

US010469717B2

(12) **United States Patent**
Kim

(10) **Patent No.:** **US 10,469,717 B2**
(45) **Date of Patent:** ***Nov. 5, 2019**

(54) **CAMERA MODULE AND MOBILE PHONE USING THE SAME**

(71) Applicant: **LG INNOTEK CO., LTD.**, Seoul (KR)

(72) Inventor: **Duhee Kim**, Seoul (KR)

(73) Assignee: **LG INNOTEK CO., LTD.**, Seoul (KR)

(*) Notice: Subject to any disclaimer, the term of this patent is extended or adjusted under 35 U.S.C. 154(b) by 88 days.

This patent is subject to a terminal disclaimer.

(21) Appl. No.: **15/418,076**

(22) Filed: **Jan. 27, 2017**

(65) **Prior Publication Data**

US 2017/0142307 A1 May 18, 2017

Related U.S. Application Data

(63) Continuation of application No. 14/329,610, filed on Jul. 11, 2014, now Pat. No. 9,578,216, which is a (Continued)

(30) **Foreign Application Priority Data**

Dec. 21, 2009 (KR) 10-2009-0128159

(51) **Int. Cl.**

H04N 5/225 (2006.01)

G02B 7/08 (2006.01)

(Continued)

(52) **U.S. Cl.**

CPC **H04N 5/2254** (2013.01); **G02B 7/006** (2013.01); **G02B 7/08** (2013.01); **G02B 7/09** (2013.01);

(Continued)

(58) **Field of Classification Search**

CPC .. **H04N 5/2254**; **H04N 5/2257**; **H04N 5/2253**; **H04N 5/2252**; **H04M 1/0264**;

(Continued)

(56) **References Cited**

U.S. PATENT DOCUMENTS

5,844,719 A 12/1998 Wada
5,932,984 A 8/1999 Murakami et al.

(Continued)

FOREIGN PATENT DOCUMENTS

JP 2007-248964 A 9/2007
JP 2007248964 A 9/2007

(Continued)

Primary Examiner — Pritham D Prabhakher

(74) *Attorney, Agent, or Firm* — Saliwanchik, Lloyd & Eisenschenk

(57) **ABSTRACT**

Disclosed herein is a camera module comprising: a circuit board; a frame coupled to the circuit board; an image sensor on the circuit board; a bobbin on the frame, a plurality of lenses being inside the bobbin; a coil wound on the bobbin, the bobbin moving to two directions based on a current applied to the coil; a magnet configured to interact the coil; and a yoke on the frame, the magnet being at an inner side of the yoke, wherein the bobbin moves to a first direction when a forward current is applied to the coil and to a second direction when a reverse current is applied to the coil.

23 Claims, 3 Drawing Sheets

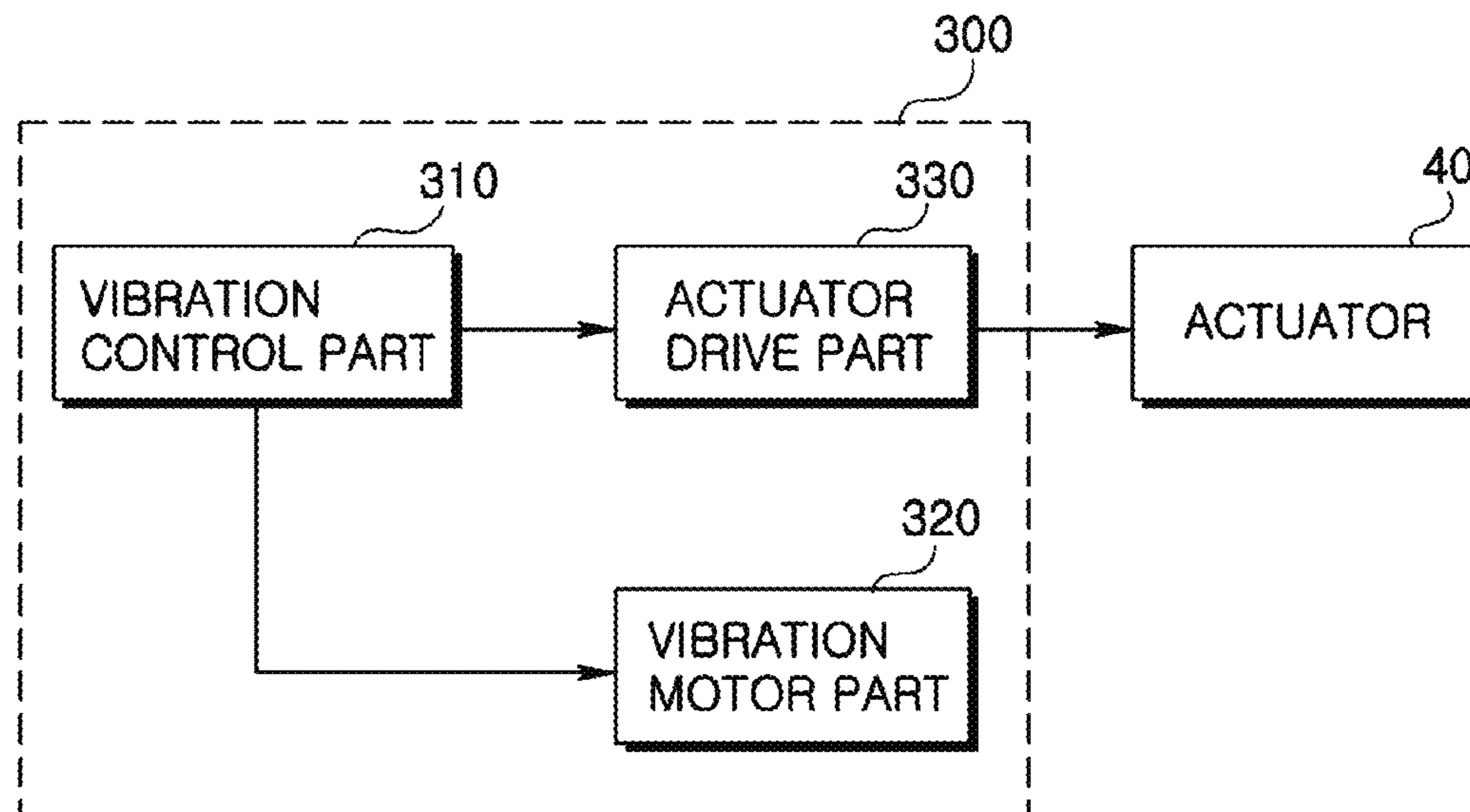

Related U.S. Application Data

continuation of application No. 13/974,622, filed on Aug. 23, 2013, now Pat. No. 8,792,938, which is a continuation of application No. 12/974,675, filed on Dec. 21, 2010, now Pat. No. 8,543,159.

(51) **Int. Cl.**

G02B 3/10 (2006.01)
G03B 5/00 (2006.01)
H04M 1/02 (2006.01)
H04N 1/00 (2006.01)
H04N 5/232 (2006.01)
G02B 7/00 (2006.01)
G02B 7/09 (2006.01)
G03B 13/36 (2006.01)
G02B 5/20 (2006.01)
G03B 3/10 (2006.01)

(52) **U.S. Cl.**

CPC **G03B 3/10** (2013.01); **G03B 5/00** (2013.01); **G03B 13/36** (2013.01); **H04M 1/0264** (2013.01); **H04M 1/0266** (2013.01); **H04N 1/00307** (2013.01); **H04N 5/2252** (2013.01); **H04N 5/2253** (2013.01); **H04N 5/2257** (2013.01); **H04N 5/232** (2013.01); **G02B 5/208** (2013.01); **G03B 2205/0007** (2013.01)

(58) **Field of Classification Search**

CPC .. H04M 1/00307; H04M 1/0266; G02B 7/09; G02B 7/006; G02B 5/208; G03B 13/36; G03B 3/10; G03B 2205/0007
 USPC 348/357
 See application file for complete search history.

(56)

References Cited

U.S. PATENT DOCUMENTS

7,006,139 B2 2/2006 Ohkawara
 7,202,905 B2 4/2007 Castaneda et al.
 7,271,845 B2 9/2007 Aoyama et al.

7,463,436 B2* 12/2008 Takahashi G02B 7/08
 348/345
 7,468,753 B2 12/2008 Butterworth et al.
 7,565,070 B1 7/2009 Gutierrez
 8,543,159 B2 9/2013 Kim
 8,792,938 B2 7/2014 Kim
 2007/0086769 A1* 4/2007 Watanabe G02B 7/022
 396/133
 2007/0248344 A1* 10/2007 Santo G02B 7/023
 396/91
 2007/0263115 A1* 11/2007 Horidan H04N 5/2254
 348/340
 2008/0055753 A1* 3/2008 Takahashi G02B 7/08
 359/824
 2008/0192124 A1* 8/2008 Nagasaki G02B 7/02
 348/208.11
 2008/0198254 A1* 8/2008 Nagasaki G02B 7/08
 348/335
 2009/0213264 A1 8/2009 Kim
 2009/0237815 A1* 9/2009 Kim G02B 7/023
 359/811
 2009/0305695 A1 12/2009 Bear et al.
 2009/0316040 A1* 12/2009 Takatsuka G02B 7/08
 348/376
 2010/0053412 A1* 3/2010 Sekimoto G03B 9/08
 348/335
 2010/0134906 A1 6/2010 Nakamura et al.
 2010/0157143 A1* 6/2010 Kim H04N 5/2253
 348/374
 2010/0158506 A1* 6/2010 Sekimoto G03B 9/02
 396/508
 2010/0182490 A1* 7/2010 Seol G02B 7/08
 348/345
 2013/0128108 A1 5/2013 Oh et al.
 2013/0235263 A1 9/2013 Ryu

FOREIGN PATENT DOCUMENTS

JP 2009-282090 A 12/2009
 JP 2009282090 A 12/2009
 KR 20-0376032 Y1 3/2005
 KR 200376032 Y1 3/2005
 KR 10-2009-0004286 A 1/2009
 KR 102009000428 A 1/2009
 KR 10-2011-0013966 A 2/2011
 KR 20110013966 A 2/2011

* cited by examiner

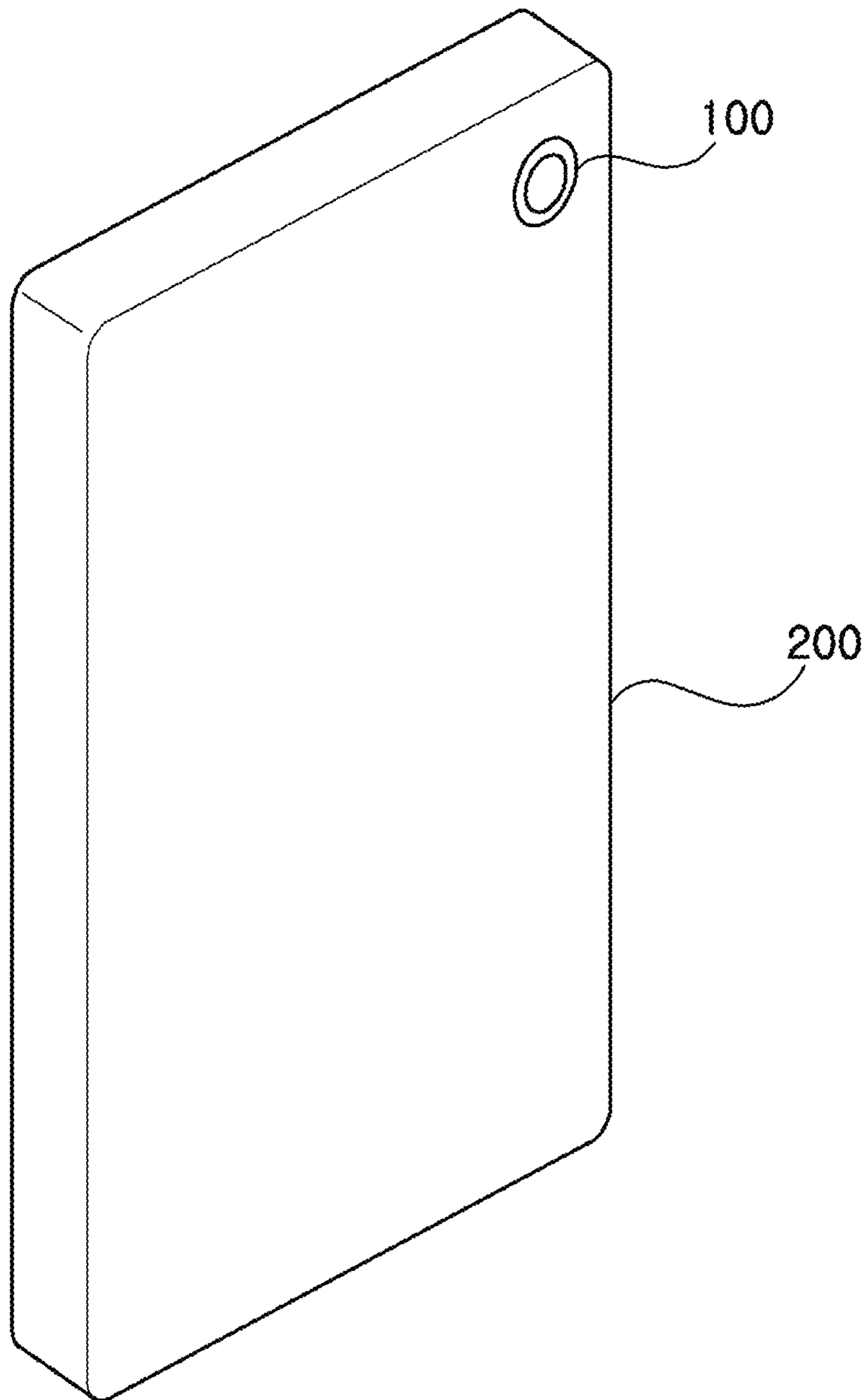

FIG. 1

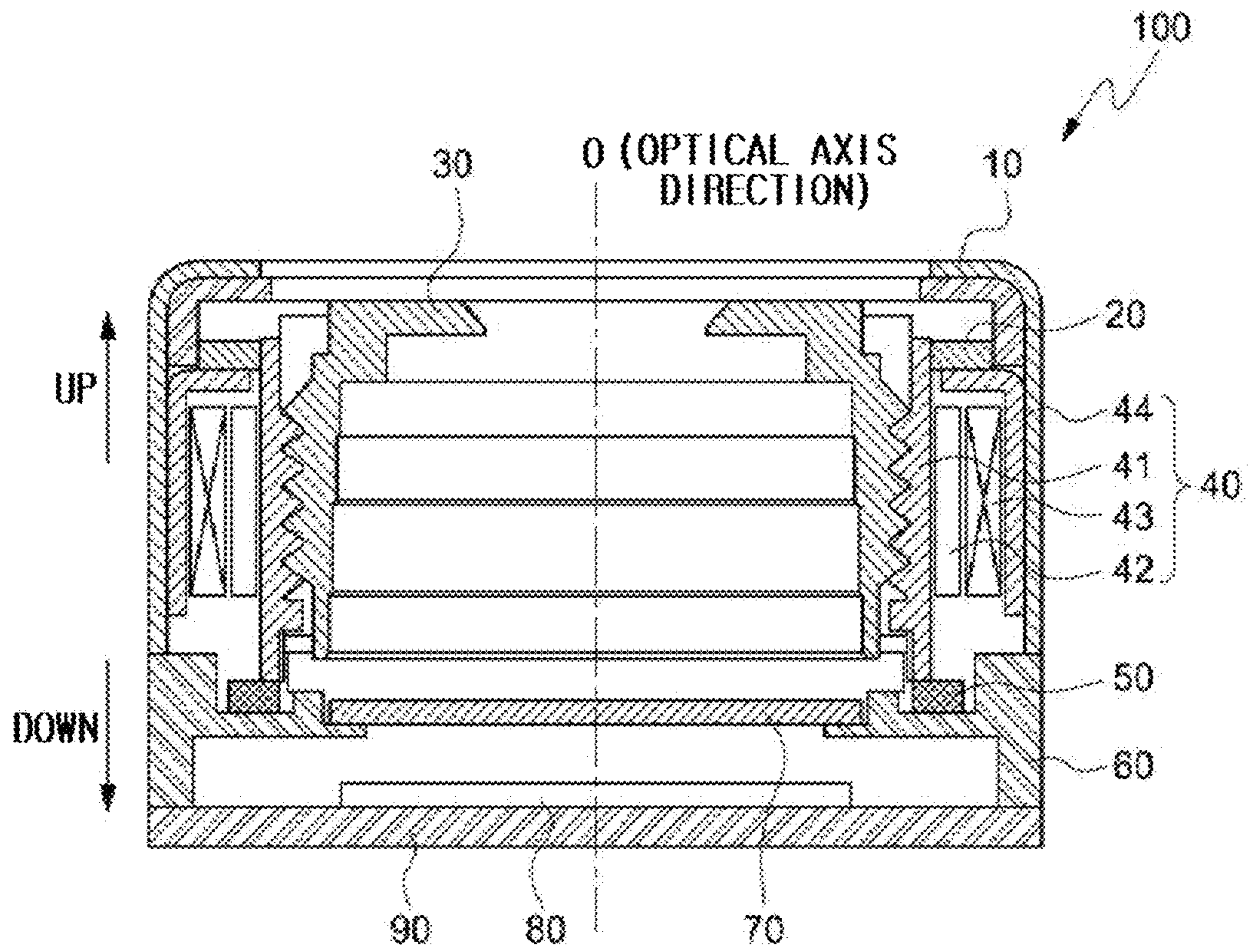

FIG. 2

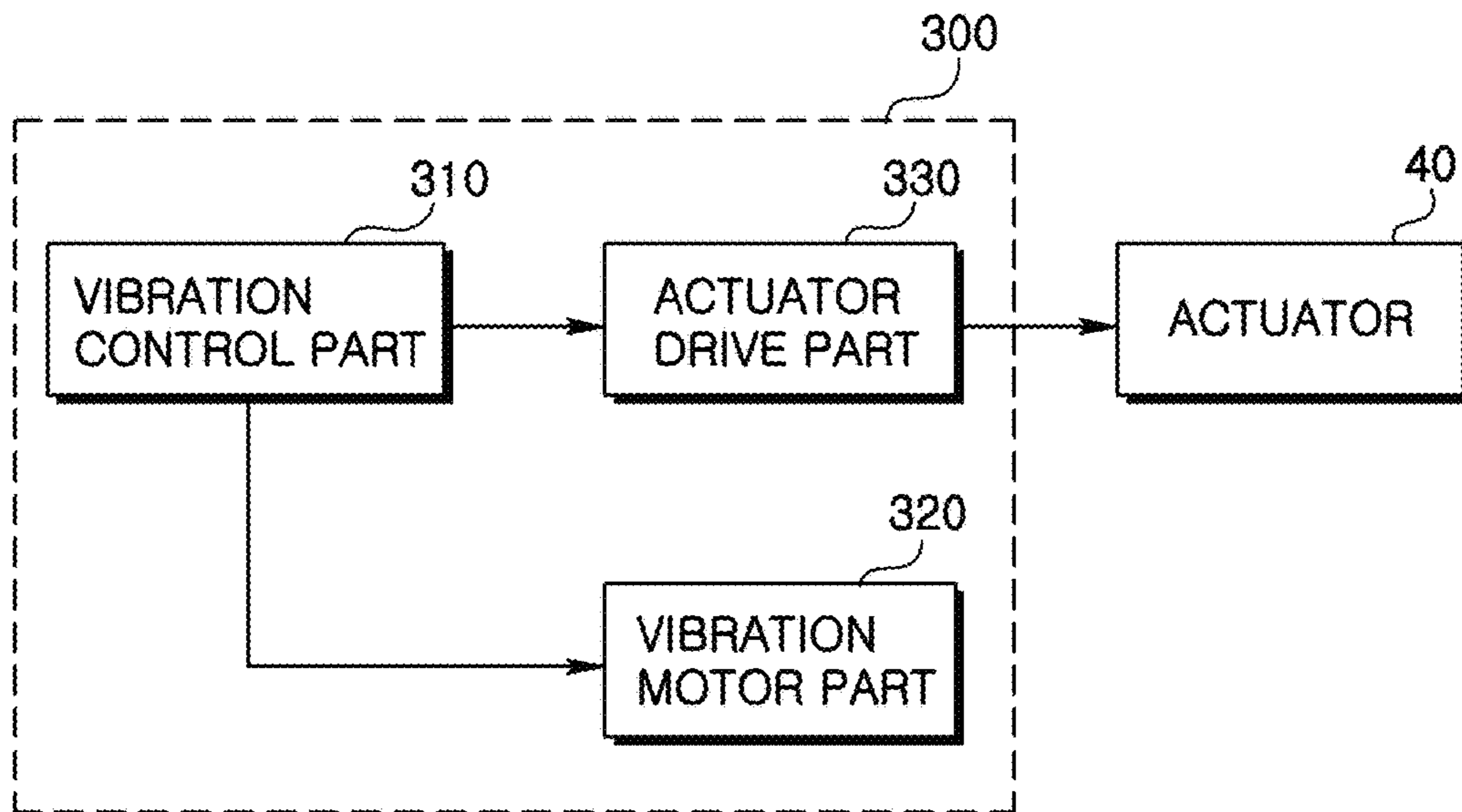

FIG. 3

CAMERA MODULE AND MOBILE PHONE USING THE SAME

CROSS-REFERENCE TO RELATED APPLICATIONS

This application is a continuation of U.S. application Ser. No. 14/329,610, filed Jul. 11, 2014; which is a continuation of U.S. application Ser. No. 13/974,622, filed Aug. 23, 2013, now U.S. Pat. No. 8,792,938, issued Jul. 29, 2014; which is a continuation of U.S. application Ser. No. 12/974,675, filed Dec. 21, 2010, now U.S. Pat. No. 8,543,159, issued Sep. 24, 2013; which claims the benefit under 35 U.S.C. § 119 of Korean Patent Application No. 10-2009-0128159, filed on Dec. 21, 2009; which are hereby incorporated by reference in their entirety.

BACKGROUND

Field of the Invention

The present invention relates to a mobile phone installed with a camera module.

Description of the Related Art

Concomitant with the development of recent communication and digital information processing technologies, a mobile phone technique integrated with information processing and computations, communications, and image information input/output has newly emerged.

Consistent with this, a mobile phone merged with a camera function has commercialized, at which system the mobile phone installed with a camera module photographs and stores moving images and still images and transfers them to the other party.

A mobile phone installed with such a camera module simply does not remain in a function of shooting an object, but is actually in a stage of adding an accessory function like a focus function of adjusting a focus of objects to be shot and a zoom function of making an object in the distance appear a near-sight or a close positioned object coming into a far distance.

A conventional lens unit of a camera module moves upward/downward along with an optical axis by a VCM (Voice Coil Motor), and through such an action, a camera module can do an auto focusing of a focal point of an object.

At this time, an upper part and a lower part of a lens unit is installed with an upper spring and an lower spring, and in a case a force applied to a lens part by a voice coil motor is greater than tension of a spring, a lens unit moves in an optical axis direction.

A camera module-installed mobile phone may operate in "vibration mode" vibrating by drive of a vibration motor, where a spring supporting a lens unit may rock simultaneously when a mobile phone is trembling due to a vibration mode.

When a spring supporting a lens unit rocks, so does a lens unit, whereby a banging sound occurs in a vibration mode as the lens unit touches a bottom surface.

BRIEF SUMMARY

The present invention provides a mobile phone installed with a camera module configured to inhibit a thud noise occurring due to a lens unit in a vibration mode of a mobile phone.

In one general aspect of the present invention, there may be provided a camera module, the camera module comprising: a circuit board; a frame coupled to the circuit board; an

image sensor on the circuit board; a bobbin on the frame, a plurality of lenses being inside the bobbin; a coil wound on the bobbin, the bobbin moving to two directions based on a current applied to the coil; a magnet configured to interact the coil; and a yoke on the frame, the magnet being at an inner side of the yoke, wherein the bobbin moves to a first direction when a forward current is applied to the coil and to a second direction when a reverse current is applied to the coil.

In some exemplary of the present invention, the magnet may be between the yoke and the coil.

In some exemplary of the present invention, the first direction may include a direction distancing from the frame along an optical axis and the second direction may include a direction approaching the frame along the optical axis.

In some exemplary of the present invention, the camera module may further comprising: a first tension member at upper part of the bobbin; and a second tension member on the frame, wherein the second tension member is placed below the bobbin.

In some exemplary of the present invention, outside part of the first tension member may be supported by an upper side of the yoke, and inside part of the first tension member may face the bobbin.

In some exemplary of the present invention, the either side of the second tension member may be spaced from the frame.

In some exemplary of the present invention, the second tension member may be isolated from the yoke.

In some exemplary of the present invention, the first tension frame may apply pressure to the upper part of the bobbin.

In some exemplary of the present invention, the camera module may further comprise a filter laid over the image sensor and below the bobbin, and configured to filter infrared inputted to the image sensor.

In some exemplary of the present invention, the camera module may further comprise a case supported by the frame.

In another general aspect of the present invention, there may be provided a mobile terminal comprising a camera module and a vibration control unit, wherein the camera module comprising: a circuit board; a frame coupled to the circuit board; an image sensor disposed on the circuit board; a bobbin on the frame, a plurality of lenses being inside the bobbin; a coil wound on the bobbin, the bobbin moving to two directions based on a current applied to the coil; a magnet configured to interact the coil; and a yoke disposed on the frame, the magnet being at an inner side of the yoke, and wherein the vibration control unit may be configured to output a first control signal and a second control signal when a signal for a vibration mode is inputted and a reverse current is applied to the coil according to the second control signal.

In some exemplary of the present invention, the mobile terminal may further comprise a vibration motor unit configured to vibrate the mobile terminal by driving a motor according to the first control signal from the vibration control unit.

In some exemplary of the present invention, the mobile terminal may further comprise an actuator drive unit configured to apply the reverse current to the coil according to the second control signal.

In some exemplary of the present invention, the yoke may comprise an upper plate and a lateral plate extended from an edge of the upper plate, and the magnet may be coupled to the lateral plate.

In some exemplary of the present invention, the frame may further comprise a supporter extended toward the image sensor from a peripheral portion of the frame.

An embodiment of the invention applies a reverse current to an actuator driving a lens unit of a camera module and thus extremely pushes a lens unit onto a tension member placed at a lower part, so that a banging sound occurring by movement of a lens unit in a vibration mode can be inhibited.

In addition, the present invention provides a mobile phone including, an actuator moving a lens; a vibration control unit outputting a first control signal and a second control signal; a vibration motor unit vibrating the mobile phone by driving a motor, when the first control signal is input, connected to the vibration control unit; and an actuator drive part applying the current to the actuator when the second control signal is input, connected to the vibration control unit.

BRIEF DESCRIPTION OF THE DRAWINGS

FIG. 1 is an outer shape diagram of a mobile phone according to an embodiment of the present invention;

FIG. 2 is a cross-section view of a camera module according to an embodiment of the present invention; and

FIG. 3 is a schematic construction diagram of a central control unit and an actuator of a mobile phone according to an embodiment of the invention.

DETAILED DESCRIPTION

Since the present invention can be applied with various changes thereto and several types of embodiments, specific embodiments intend to be exemplified in the drawings and minutely described in the detailed description. However, it should not be appreciated in a limiting sense of limiting the present invention to a specific example but to include all the changes, equivalents and replacements which fall in the spirit and technical scope of the present invention.

While terms including ordinal numbers such as a first and a second may be used to describe various components, such components are not limited to the terms. The terms are used only for the purpose of distinguishing one component from other components.

For example, a second component may be named as a first component without departing from the scope of the present invention rights, and in a similar way, the first component may be renamed as the second component.

Stated that any component is "connected" or "conjunctive" to another component, it will be appreciated to be directly connected or conjunctive to the very another component or otherwise that there exists any component in the midst of them. On the other hand, stating that any component is "directly connected" or "directly conjunctive" to another component, it should be understood that any other component does not exist therebetween.

Terms used in the present application are only used to describe a specific embodiment, not in a sense of limiting the invention. A singular form includes a plural form, otherwise stated in a different way in the context. In this application, the terms such as "include" or "have" indicate that there exist a characteristic, a number, a step, an operation, a component, other things recited in the specification or a combination thereof, but it should not be understood to preclude the existence or addition of one or more other characteristics, numbers, operations, substances, components or a combination of thereof.

In the following, a mobile phone according to an embodiment of the present invention will be described in detail referring to the attached drawings, but without regard to a drawing sign, an identical or corresponding component is assigned the same reference numeral and a redundant description regarding this will be omitted.

FIG. 1 is an outer shape diagram of a mobile phone according to the present invention.

As shown in FIG. 1, a mobile phone includes a main body **200** and a camera module **100** mounted at a setting position of the main body **200**.

FIG. 2 is a cross-sectional view of a camera module **100** according to an embodiment of the invention.

As shown in FIG. 2, a camera module **200** of the present invention includes a case **10**, an upper part tension member **20**, a lens barrel **30**, an actuator **40**, a lower part tension member **50**, a frame **60**, an IR filter **70**, an image sensor **80** and a printed circuit board **90**.

For auto focusing, an actuator **40**, that is an operating unit shifting a lens barrel **30** along with an optical axis direction **O**, is necessary, in which the present invention is a voice coil motor among actuators **40**.

An actuator **40** includes a bobbin **41**, a coil **42**, a permanent magnet **43**, and a yoke **44**.

A case **10** has a cubical form with its lower part opened, and an upper part central side is formed with a light penetration hole **11**. A lower part of a case **10** is supported by a frame **60**.

The case **10** is coupled with a frame **60** to form a frame **60**, and the space includes an upper part tension member **20**, a lens barrel **30**, an actuator **40**, and an IR filter **50**.

It is preferred that a case **10** is manufactured with plastic for an insulation between its inner part and outer part, and an injection molding for mass production is possible.

An upper part tension member **20** is a plate spring, being inserted into an upper part of a case **10**, and its outside part is supported by a yoke **44** of an actuator **40**, and its inside part faces a bobbin **41** of an actuator **40** and applies pressure to an upper side of a bobbin **41**.

A lower part tension member **50** may be into an insert injection at a bobbin **41**, and may be pasted with a bond.

A lens barrel **30** is a means of fixing and protecting a plurality of lenses, an inner side of a lens barrel **30** is stacked with a plurality of lens capable of inputting a light image of a subject sequentially according to an optical axis direction **O**.

A surrounding surface of a lens barrel **30** is formed of a screw thread **31**, and the screw thread **31** is screw-coupled to a screw thread formed at an inner-rim surface of a bobbin **41**.

The bobbin **41** is of a cylindrical shape with its upper part and lower part opened, and the inner-rim surface is formed with a screw thread corresponding to a screw thread **31** of a lens barrel **30**. The present invention may take the far distance focusing of a camera module by screw-coupling a lens barrel **30** to an inner-rim surface of a bobbin **41**.

A surrounding part of a bobbin **41** is wound perpendicular to the direction of magnetic flux by a coil **42** interacting with a permanent magnet **43**.

An inner side of a case **10** is inserted with a yoke **44** for keeping magnetic field between a coil **42** and a permanent magnet **43** from leaking from outside, and a permanent magnet **43** is mounted at an inner side of a yoke **44** to face each other based on a bobbin **41**. The yoke **44** is supported by a frame **60**.

When a voltage is applied to a coil **42**, current flowing through the coil and magnetic field of a permanent magnet

5

43 interact (Fleming's left-hand rule), and thus a bobbin 41 is inflicted with a force towards an upper side of an optical axis direction. At this time, the greater the intensity of current applied to the coil 42 is, a distance a lens barrel 30 and a bobbin 41 shift to an upper part along an optical axis direction increases.

Successively, when a voltage applied to a coil 42 is blocked, a lens barrel 30 and a bobbin 41 shift to a lower part along with an optical axis direction by an upper part tension member 20 and a lower part tension member 50 and return to its original state.

A printed circuit board 90 is mounted with an image sensor 80 transforming a light image into an electrical signal, and a frame 60 is a rectangular shape having a central opening part that can penetrate a light to an image sensor 80, and the frame 60 is positioned at a lower part of a lens barrel 30, and mounted with an IR filter 70 filtering infrared.

An image sensor 80 is placed at a lower part of a lens barrel 30 and at an upper part of a printed circuit board 90, and transforms a light image incident through a plurality of lens into an electrical signal.

The printed circuit board 90 is an FPCB (Flexible Printed Circuit Board) having a high evenness level, an outwardly extended part from an FPCB is provided with means connected to an external device (not shown).

As described above, a lens barrel 30 of the present invention is supported by elasticity force between an upper part tension member 20 and a lower part tension member 50.

FIG. 3 is a schematic construction view of a central control part 300 and an actuator 40 of a mobile phone according to an embodiment of the invention.

As illustrated in FIG. 3, a central control part 300 of a mobile phone of the invention includes a vibration control part 310 controlling vibration of a mobile phone, a vibration motor part 320 receiving an electric source voltage according to a control signal of the vibration control part 310 and driving a mobile phone in a vibration mode, and an actuator drive part 330 driving the actuator 40 of a camera module.

The vibration control part 310 processes a signal input from an external and determines if a mobile phone should be operated in a vibration mode, and if a mobile phone needs to be operated in a vibration mode, outputs a first control signal to the vibration motor part 320.

Then, the vibration motor part 320 drives a motor so that a mobile phone vibrates according to a first control signal.

If a signal telling of operating in a vibration mode from outside is input like in the case of a vibration mode when a call is terminated or in a case a user manipulates a keypad to convert a bell mode into a vibration mode, a vibration control part 310 outputs a first control signal and a second control signal informing of a vibration mode initiation to a vibration motor part 320 and an actuator drive part 330, respectively.

An actuator drive part 330 applies "forward current" to the coil 42 of an actuator 40 at the time of auto focusing action, but if a second control signal from the vibration control part 310 is input, it applies "reverse current" to the coil 42 of an actuator 40.

If a reverse current is applied to the coil 42, a bobbin 41 of an actuator 40 is inflicted with a force toward a lower side of an optical axis direction by Fleming's left-hand rule. Then, a lens barrel 30 including a lens unit connected to a bobbin 41 is maximally pushed to a lower part tension member 50, thereby presumably inhibiting a banging sound occurring according to the falter of a lens unit in a vibration mode of a mobile phone.

6

A circuit of applying a forward current and a reverse current to the actuator 40 may be variously realized, and a related specific description will be omitted.

The vibration control part 310 may output simultaneously a first control signal and a second control signal, but it may output a first control signal a pre-defined time after a second control signal is outputted.

A vibration control part 310 of the present invention may set a certain time interval while a second control signal is output and afterwards a first control signal is output, so that a vibration mode after a lens barrel 30 is maximally pushed to a lower part tension member 50 may be initiated and a banging sound occurring according to the falter of a lens unit may be inhibited.

At this time, a certain time interval is a time required so that a lens barrel 30 closely couples to a lower part tension member 50.

While the present invention has been described in detail through representative embodiments in the above part, those skilled in the art would understand that various modifications can be made in the described embodiment without departing from the scope of the present invention.

What is claimed is:

1. A mobile terminal comprising:

a camera module and a control part, the camera module comprising:

a yoke;

a bobbin disposed inside the yoke;

a lens barrel coupled to the bobbin;

a lens disposed in and fixed to the lens barrel;

a coil disposed on an outer lateral surface of the bobbin;

a magnet disposed on the yoke and facing the coil;

a frame disposed below the yoke;

a circuit board;

an image sensor disposed on the circuit board, wherein the lens is disposed over the image sensor; and

first and second plate springs coupled to the bobbin;

wherein the control part controls a current applied to the coil,

wherein the bobbin moves in a first direction when a forward current is applied to the coil and in a second direction when a reverse current is applied to the coil, wherein the first direction is opposite to the second direction,

wherein the lens barrel comprises an upper part disposed above the lens and comprises a hole,

wherein an inner peripheral surface of the upper part of the lens barrel comprises an inclined surface,

wherein the first plate spring is coupled to an upper portion of the bobbin, and the second plate spring is coupled to a lower portion of the bobbin,

wherein a first screw thread is formed on an inner lateral surface of the bobbin, and a second screw thread is formed on an outer lateral surface of the lens barrel and coupled with the first screw thread, and

wherein an inner diameter of the second screw thread is larger than a diameter of the outer lateral surface of the lens barrel.

2. The mobile terminal of claim 1, wherein the control part comprises:

a vibration control part outputting a first control signal for vibrating the mobile terminal and a second control signal for driving an actuator;

a vibration motor part vibrating the mobile terminal by driving a motor in response to the first control signal; and

7

an actuator drive part driving the actuator in response to the second control signal, wherein the actuator is formed by the bobbin, the coil, the magnet, and the yoke, and wherein the actuator is disposed inside the camera module and configured to perform an auto focusing function by applying a forward current to the coil and to perform moving the bobbin and the lens toward a lower side of an optical-axis direction by applying a reverse current to the coil in response to the second control signal.

3. The mobile terminal of claim 2, wherein the vibration control part simultaneously outputs the first control signal and the second control signal.

4. The mobile terminal of claim 2, wherein the vibration control unit outputs the first control signal after the second control signal is output.

5. The mobile terminal of claim 1, wherein the first direction includes a direction in which the bobbin is spaced apart from the frame along an optical axis and the second direction includes a direction in which the bobbin is extended toward the frame along the optical axis.

6. The mobile terminal of claim 1, wherein an outside part of the first plate spring is supported by an upper side of the yoke, and an inside part of the first plate spring is coupled with the bobbin.

7. The mobile terminal of claim 1, wherein the second plate spring is coupled with the bobbin and the frame.

8. The mobile terminal of claim 1, further comprising: a filter disposed between the image sensor and the bobbin, and configured to filter infrared light.

9. The mobile terminal of claim 8, wherein the frame comprises a protrusion protruding from an upper surface of the frame,

wherein the filter is accommodated in the protrusion, wherein an inner lateral surface of the protrusion faces an outer lateral surface of the filter, and wherein the inner lateral surface of the protrusion is spaced from the outer lateral surface of the filter.

10. The mobile terminal of claim 1, further comprising a case coupled with the frame, and wherein the case accommodates the yoke.

11. The mobile terminal of claim 1, wherein when an intensity of the front or reverse current increases, a distance that the bobbin travels away from an initial position increases.

12. The mobile terminal of claim 1, wherein the lens barrel comprises a stepped part recessed inwardly from the outer lateral surface of the lens barrel between the second screw thread and an upper end of the lens barrel.

13. The mobile terminal of claim 1, wherein an extension part is formed on the inner lateral surface of the bobbin at a lower side of the first screw thread, and wherein the extension part has an inner diameter corresponding to an inner diameter of the first screw thread and a shape different from a shape of the first screw thread.

14. The mobile terminal of claim 1, wherein the first screw thread comprises an inclined plane connected to the inner lateral surface of the bobbin to form an obtuse angle.

15. The mobile terminal of claim 1, wherein an inclined plane of the lens barrel is connected to an upper surface of the lens barrel to form an obtuse angle.

16. The mobile terminal of claim 1, wherein five lenses are accommodated in the lens barrel.

17. A mobile terminal comprising: a camera module and a control part, the camera module comprising:

8

a yoke;
a bobbin disposed inside the yoke;
a lens barrel coupled to the bobbin;
a lens disposed in and fixed to the lens barrel;
a coil disposed on an outer lateral surface of the bobbin;
and
a magnet disposed on the yoke and facing the coil;
wherein the control part controls a current applied to the coil,

wherein the bobbin moves in a first direction when a forward current is applied to the coil and in a second direction when a reverse current is applied to the coil, wherein the first direction is opposite to the second direction,

wherein the lens barrel comprises an upper part disposed above the lens and comprises a hole, wherein an inner peripheral surface of the upper part of the lens barrel comprises an inclined surface, wherein the control part comprises:

a vibration control part outputting a first control signal for vibrating the mobile terminal and a second control signal for driving an actuator;
a vibration motor part vibrating the mobile terminal by driving a motor in response to the first control signal;
and

an actuator drive part driving the actuator in response to the second control signal,

wherein the actuator is formed by the bobbin, the coil, the magnet, and the yoke,

wherein the actuator is disposed inside the camera module and configured to perform an auto focusing function by applying a forward current to the coil and to perform moving the bobbin and the lens toward a lower side of an optical-axis direction by applying a reverse current to the coil in response to the second control signal, and wherein the vibration control part simultaneously outputs the first control signal and the second control signal.

18. A mobile terminal comprising:

a camera module and a control part, the camera module comprising:

a yoke;
a bobbin disposed inside the yoke;
a lens barrel coupled to the bobbin;
a lens disposed in and fixed to the lens barrel;
a coil disposed on an outer lateral surface of the bobbin;
and
a magnet disposed on the yoke and facing the coil;
wherein the control part controls a current applied to the coil,

wherein the bobbin moves in a first direction when a forward current is applied to the coil and in a second direction when a reverse current is applied to the coil, wherein the first direction is opposite to the second direction,

wherein the lens barrel comprises an upper part disposed above the lens and comprises a hole, wherein an inner peripheral surface of the upper part of the lens barrel comprises an inclined surface, wherein the control part comprises:

a vibration control part outputting a first control signal for vibrating the mobile terminal and a second control signal for driving an actuator;
a vibration motor part vibrating the mobile terminal by driving a motor in response to the first control signal;
and

an actuator drive part driving the actuator in response to the second control signal,

9

wherein the actuator is formed by the bobbin, the coil, the magnet, and the yoke,
 wherein the actuator is disposed inside the camera module and configured to perform an auto focusing function by applying a forward current to the coil and to perform moving the bobbin and the lens toward a lower side of an optical-axis direction by applying a reverse current to the coil in response to the second control signal, and wherein the vibration control unit outputs the first control signal after the second control signal is output.

19. A mobile terminal comprising:

a camera module and a control part, the camera module comprising:

a yoke;

a bobbin disposed inside the yoke;

a lens barrel coupled to the bobbin;

a lens disposed in and fixed to the lens barrel;

a coil disposed on an outer lateral surface of the bobbin;

a magnet disposed on the yoke and facing the coil;

a frame disposed below the yoke;

a circuit board;

an image sensor disposed on the circuit board, wherein the lens is disposed over the image sensor; and

first and second plate springs coupled to the bobbin;

wherein the control part controls a current applied to the coil,

wherein the bobbin moves in a first direction when a forward current is applied to the coil and in a second direction when a reverse current is applied to the coil, wherein the first direction is opposite to the second direction,

wherein the lens barrel comprises an upper part disposed above the lens and comprises a hole,

wherein an inner peripheral surface of the upper part of the lens barrel comprises an inclined surface,

wherein the first plate spring is coupled to an upper portion of the bobbin, and the second plate spring is coupled to a lower portion of the bobbin, and

wherein an outside part of the first plate spring is supported by an upper side of the yoke, and an inside part of the first plate spring is coupled with the bobbin.

20. A mobile terminal comprising:

a camera module and a control part, the camera module comprising:

a yoke;

a bobbin disposed inside the yoke;

a lens barrel coupled to the bobbin;

a lens disposed in and fixed to the lens barrel;

a coil disposed on an outer lateral surface of the bobbin;

a magnet disposed on the yoke and facing the coil;

a frame disposed below the yoke;

a circuit board;

an image sensor disposed on the circuit board, wherein the lens is disposed over the image sensor; and

first and second plate springs coupled to the bobbin;

wherein the control part controls a current applied to the coil,

wherein the bobbin moves in a first direction when a forward current is applied to the coil and in a second direction when a reverse current is applied to the coil, wherein the first direction is opposite to the second direction,

wherein the lens barrel comprises an upper part disposed above the lens and comprises a hole,

wherein an inner peripheral surface of the upper part of the lens barrel comprises an inclined surface,

10

wherein the first plate spring is coupled to an upper portion of the bobbin, and the second plate spring is coupled to a lower portion of the bobbin,

wherein a first screw thread is formed on an inner lateral surface of the bobbin, and a second screw thread is formed on an outer lateral surface of the lens barrel and coupled with the first screw thread, and

wherein the lens barrel comprises a stepped part recessed inwardly from the outer lateral surface of the lens barrel between the second screw thread and an upper end of the lens barrel.

21. A mobile terminal comprising:

a camera module and a control part, the camera module comprising:

a yoke;

a bobbin disposed inside the yoke;

a lens barrel coupled to the bobbin;

a lens disposed in and fixed to the lens barrel;

a coil disposed on an outer lateral surface of the bobbin;

a magnet disposed on the yoke and facing the coil;

a frame disposed below the yoke;

a circuit board;

an image sensor disposed on the circuit board, wherein the lens is disposed over the image sensor; and

first and second plate springs coupled to the bobbin;

wherein the control part controls a current applied to the coil,

wherein the bobbin moves in a first direction when a forward current is applied to the coil and in a second direction when a reverse current is applied to the coil, wherein the first direction is opposite to the second direction,

wherein the lens barrel comprises an upper part disposed above the lens and comprises a hole,

wherein an inner peripheral surface of the upper part of the lens barrel comprises an inclined surface,

wherein the first plate spring is coupled to an upper portion of the bobbin, and the second plate spring is coupled to a lower portion of the bobbin,

wherein a first screw thread is formed on an inner lateral surface of the bobbin, and a second screw thread is formed on an outer lateral surface of the lens barrel and coupled with the first screw thread,

wherein an extension part is formed on the inner lateral surface of the bobbin at a lower side of the first screw thread, and

wherein the extension part has an inner diameter corresponding to an inner diameter of the first screw thread and a shape different from a shape of the first screw thread.

22. A mobile terminal comprising:

a camera module and a control part, the camera module comprising:

a yoke;

a bobbin disposed inside the yoke;

a lens barrel coupled to the bobbin;

a lens disposed in and fixed to the lens barrel;

a coil disposed on an outer lateral surface of the bobbin;

a magnet disposed on the yoke and facing the coil;

a frame disposed below the yoke;

a circuit board;

an image sensor disposed on the circuit board, wherein the lens is disposed over the image sensor; and

first and second plate springs coupled to the bobbin;

wherein the control part controls a current applied to the coil,

11

wherein the bobbin moves in a first direction when a forward current is applied to the coil and in a second direction when a reverse current is applied to the coil, wherein the first direction is opposite to the second direction,
 wherein the lens barrel comprises an upper part disposed above the lens and comprises a hole,
 wherein an inner peripheral surface of the upper part of the lens barrel comprises an inclined surface,
 wherein the first plate spring is coupled to an upper portion of the bobbin, and the second plate spring is coupled to a lower portion of the bobbin,
 wherein a first screw thread is formed on an inner lateral surface of the bobbin, and a second screw thread is formed on an outer lateral surface of the lens barrel and coupled with the first screw thread, and
 wherein the first screw thread comprises an inclined plane connected to the inner lateral surface of the bobbin to form an obtuse angle.

23. A mobile terminal comprising:
 a camera module and a control part, the camera module comprising:
 a yoke;
 a bobbin disposed inside the yoke;
 a lens barrel coupled to the bobbin;
 a lens disposed in and fixed to the lens barrel;
 a coil disposed on an outer lateral surface of the bobbin;
 a magnet disposed on the yoke and facing the coil;

12

a frame disposed below the yoke;
 a circuit board;
 an image sensor disposed on the circuit board, wherein the lens is disposed over the image sensor; and
 first and second plate springs coupled to the bobbin;
 wherein the control part controls a current applied to the coil,
 wherein the bobbin moves in a first direction when a forward current is applied to the coil and in a second direction when a reverse current is applied to the coil, wherein the first direction is opposite to the second direction,
 wherein the lens barrel comprises an upper part disposed above the lens and comprises a hole,
 wherein an inner peripheral surface of the upper part of the lens barrel comprises an inclined surface,
 wherein the first plate spring is coupled to an upper portion of the bobbin, and the second plate spring is coupled to a lower portion of the bobbin,
 wherein a first screw thread is formed on an inner lateral surface of the bobbin, and a second screw thread is formed on an outer lateral surface of the lens barrel and coupled with the first screw thread, and
 wherein the inclined plane of the lens barrel is connected to an upper surface of the lens barrel to form an obtuse angle.

* * * * *