



(12) **United States Patent**
Morse et al.

(10) **Patent No.:** **US 10,466,516 B2**
(45) **Date of Patent:** **Nov. 5, 2019**

(54) **CONTROL SYSTEM INCLUDING A BEAM STABILIZER AND A PHASE MODULATION CAPABLE ACOUSTO-OPTIC MODULATOR FOR DIVERTING LASER OUTPUT INTENSITY NOISE TO A FIRST ORDER LASER LIGHT BEAM AND RELATED METHODS**

(52) **U.S. Cl.**
CPC **G02F 1/113** (2013.01); **G02F 1/292** (2013.01); **G02F 1/33** (2013.01); **G02F 1/332** (2013.01);
(Continued)

(58) **Field of Classification Search**
CPC G02F 1/11; G02F 1/113; G02F 2002/008; G02B 27/1093; G02B 27/10; H03K 19/14;
(Continued)

(71) Applicant: **Harris Corporation**, Melbourne, FL (US)

(72) Inventors: **Randall K. Morse**, Palm Bay, FL (US); **Peter A. Wasilousky**, Indialantic, FL (US); **Lee M. Burberry**, West Melbourne, FL (US); **Michael R. Lange**, Melbourne, FL (US); **Catheryn D. Logan**, Melbourne, FL (US); **Christopher A. Corey**, Palm Bay, FL (US)

(56) **References Cited**

U.S. PATENT DOCUMENTS

3,731,231 A 5/1973 Torguet
4,256,362 A 3/1981 Bardos
(Continued)

FOREIGN PATENT DOCUMENTS

CA 2484320 4/2005
DE 102006040843 3/2007

OTHER PUBLICATIONS

U.S. Appl. No. 15/918,184, filed Mar. 12, 2018.
(Continued)

Primary Examiner — Collin X Beatty

(74) *Attorney, Agent, or Firm* — Allen, Dyer, Doppelt + Gilchrist, P.A.

(73) Assignee: **HARRIS CORPORATION**, Melbourne, FL (US)

(*) Notice: Subject to any disclaimer, the term of this patent is extended or adjusted under 35 U.S.C. 154(b) by 30 days.

(21) Appl. No.: **15/900,936**

(22) Filed: **Feb. 21, 2018**

(65) **Prior Publication Data**
US 2018/0173027 A1 Jun. 21, 2018

Related U.S. Application Data

(63) Continuation-in-part of application No. 15/342,372, filed on Nov. 3, 2016, now Pat. No. 9,958,711.

(51) **Int. Cl.**
G02F 1/11 (2006.01)
H01S 3/00 (2006.01)
(Continued)

(57) **ABSTRACT**

A laser system may include a laser source configured to generate a laser light beam, a beam stabilizer downstream from the laser light source, and an acousto-optic modulator (AOM). The AOM may include an acousto-optic medium configured to receive the laser light beam, and a phased array transducer including a plurality of electrodes coupled to the acousto-optic medium and configured to cause the acousto-optic medium to output a zero order laser light beam and a first order diffracted laser light beam. The system may further include a photodetector configured to receive a
(Continued)

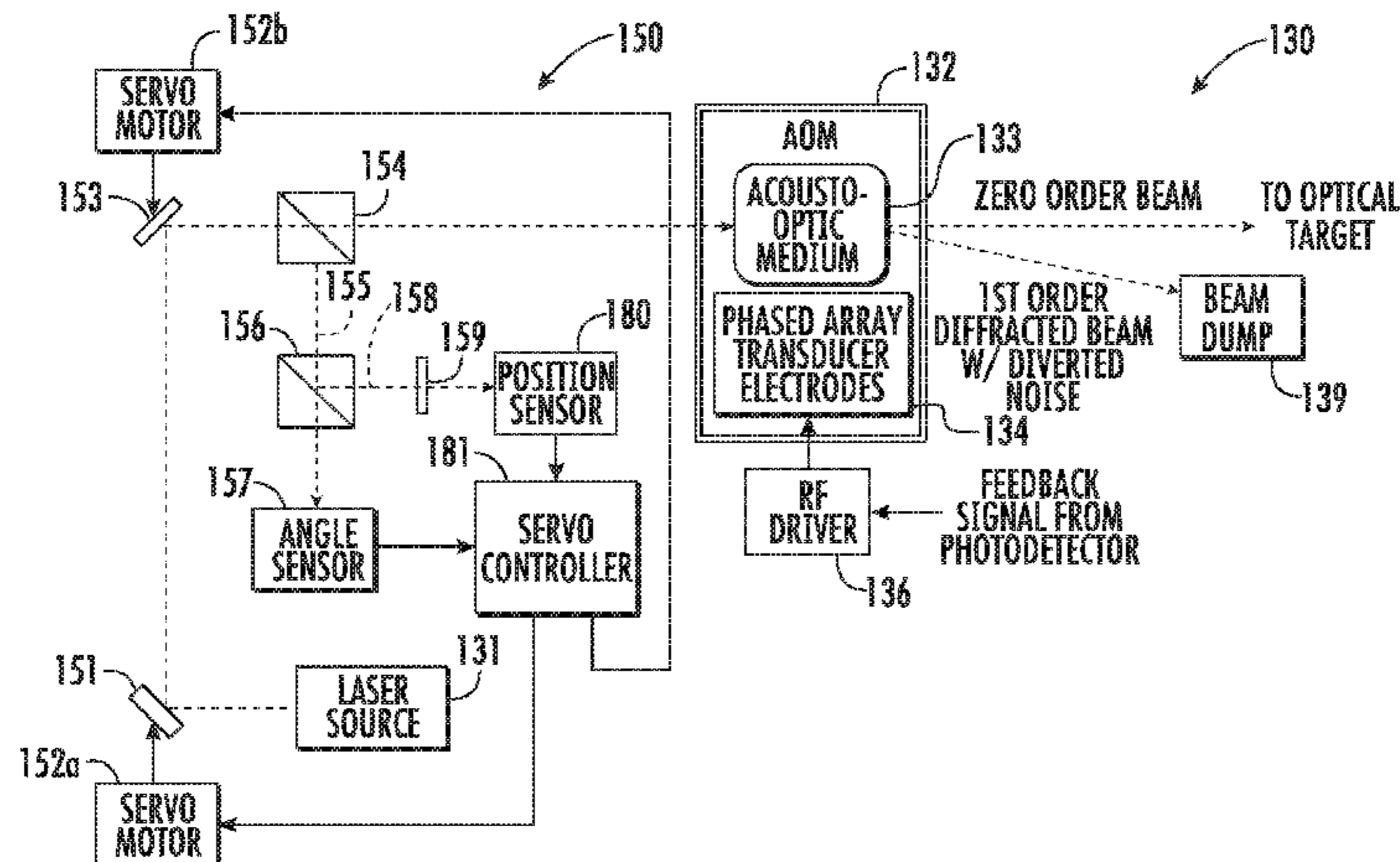

sampled laser light beam split from the zero order beam and generate a feedback signal associated therewith, and an RF driver configured to generate an RF drive signal to the phased array transducer electrodes so that noise is diverted to the first order diffracted laser light beam based upon the feedback signal.

23 Claims, 8 Drawing Sheets

- (51) **Int. Cl.**
G02F 1/33 (2006.01)
G02F 1/29 (2006.01)
- (52) **U.S. Cl.**
 CPC *H01S 3/0085* (2013.01); *G02F 2201/58* (2013.01)
- (58) **Field of Classification Search**
 CPC B23K 26/067; B23K 26/362; G21K 1/00;
 H01L 21/0273; H01L 21/268; H01L
 21/67115; H01S 3/0085
 USPC 359/285, 307
 See application file for complete search history.

(56) **References Cited**

U.S. PATENT DOCUMENTS

4,672,192	A *	6/1987	Muka	G02F 1/113 250/205
4,956,650	A	9/1990	Allen et al.	
5,363,363	A	11/1994	Gage	
5,373,385	A	12/1994	Darcie et al.	
5,386,221	A	1/1995	Allen et al.	
5,631,762	A	5/1997	Kataoka	
5,923,460	A	7/1999	Stewart et al.	
6,295,157	B1	9/2001	Allen et al.	
6,320,989	B1	11/2001	Montgomery et al.	
6,487,324	B2	11/2002	Montgomery et al.	
6,538,690	B1	3/2003	Montgomery et al.	
6,621,511	B2	9/2003	Shibayama et al.	
6,765,709	B1	7/2004	Montgomery et al.	
6,870,658	B2	3/2005	Wasilousky et al.	
7,483,196	B2	1/2009	Allen et al.	
7,538,929	B2	5/2009	Wasilousky	
7,667,882	B2	2/2010	Adibi et al.	
7,920,265	B1	4/2011	George	
8,442,373	B2	5/2013	Hartl et al.	
2009/0084991	A1	4/2009	Ichimura et al.	
2016/0313417	A1	10/2016	Kawabata et al.	

OTHER PUBLICATIONS

U.S. Appl. No. 15/918,217, filed Mar. 12, 2018.

Nadlinger, David “Laser Intensity Stabilization and Pulse Shaping for Trapped-Ion Experiments using Acousto-Optic Modulators” Thesis; Physics BSc Semester Project: Fall Semester 2013 with the Trapped Ion Quantum Information Group ETH Zurich. <http://www.tiqi.ethz.ch/publications-and-awards/semester-theses.html>: pp. 45. *** See Priority U.S. Appl. No. 15/342,372, filed Nov. 3, 2016.

Ye et al. “Delivery of high-stability optical and microwave frequency standards over an optical fiber network” <https://www.osapublishing.org/josab/abstract.cfm?UR:#josab-20-7-1459>: Journal of the Optical Society of America B vol. 20, Issue 7, pp. 1459-1467 (2003), Abstract Only *** See Priority U.S. Appl. No. 15/342,372, filed Nov. 3, 2016.

Fuller et al. “Experimental Implementations of Two-Dimensional Fourier Transform Electronic Spectroscopy” <http://www.annualreviews.org/doi/abs/10.1146/annurev-physchem-040513-103623>: Annual Review of Physical Chemistry vol. 66: 667-690 (Volume publication date Apr. 2015) Abstract Only *** See Priority U.S. Appl. No. 15/342,372, filed Nov. 3, 2016.

A. Gh. Podoleanu, “Optical coherence tomography” <http://onlinelibrary.wiley.com/doi/10.1111/j.1365-2818.2012.03619.x/pdf>: Journal of Microscopy, 2012; accepted Mar. 9, 2012: pp. 11. *** See Priority U.S. Appl. No. 15/342,372, filed Nov. 3, 2016.

Slater, Dan “Passive long range acousto-optic sensor” SPIE 6304, Free-Space Laser Communications VI, 63040E (Sep. 1, 2006); Abstract Only *** See Priority U.S. Appl. No. 15/342,372, filed Nov. 3, 2016.

U.S. Appl. No. 15/342,350, filed Nov. 3, 2016.

U.S. Appl. No. 15/342,357, filed Nov. 3, 2016.

Debnath et al., “Demonstration of a small programmable quantum computer with atomic qubits”, Macmillian Publishers Limited, Letter/Nature/vol. 536, Aug. 2016, pp. 63-66.

Mizrahi et al., “Quantum control of qubits and atomic motion using ultrafast laser pulses”, Applied Physics B, Lasers and Optics, Nov. 2013, pp. 45-61.

Giehr, “Laser intensity stabilisation”, Semester Thesis, Institute for Quantum Electronics, May 2014, pp. 1-30.

Nagerl et al., “Laser addressing of individual ions in a linear ion trap”, Physical Review A, vol. 60, No. 1, Jul. 1999, pp. 145-148.

Campbell et al., “Ultrafast gates for single atomic qubits”, Joint Quantum Institute, May 2010, pp. 1-10.

Ballance et al., “High-fidelity quantum logic gates using trapped-ion hyperfine qubits”, Physical Review Letters, Aug. 2016, pp. 060504-1-060504-6.

Robert Bobrowicz, “Evaluation of dynamic range in acousto-optic phase processor”, Institute of Fundamental Electronics, Military University of Technology, May 2000, pp. 715-718.

J. C. Poncot, “Advanced multi-channel bragg cells for 2D interferometric phase-frequency measurements”, Thomson-Sintra/DTAS, Oct. 1993, pp. 485-490.

* cited by examiner

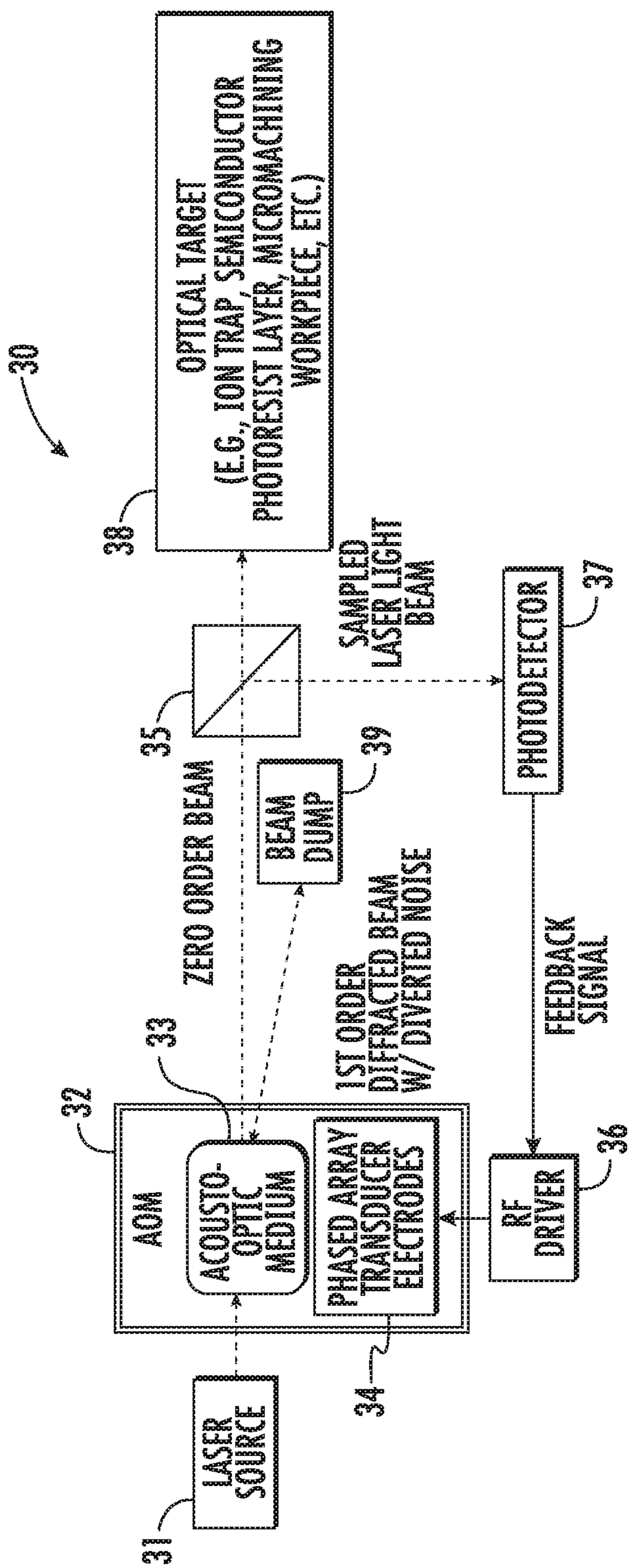

FIG. 1

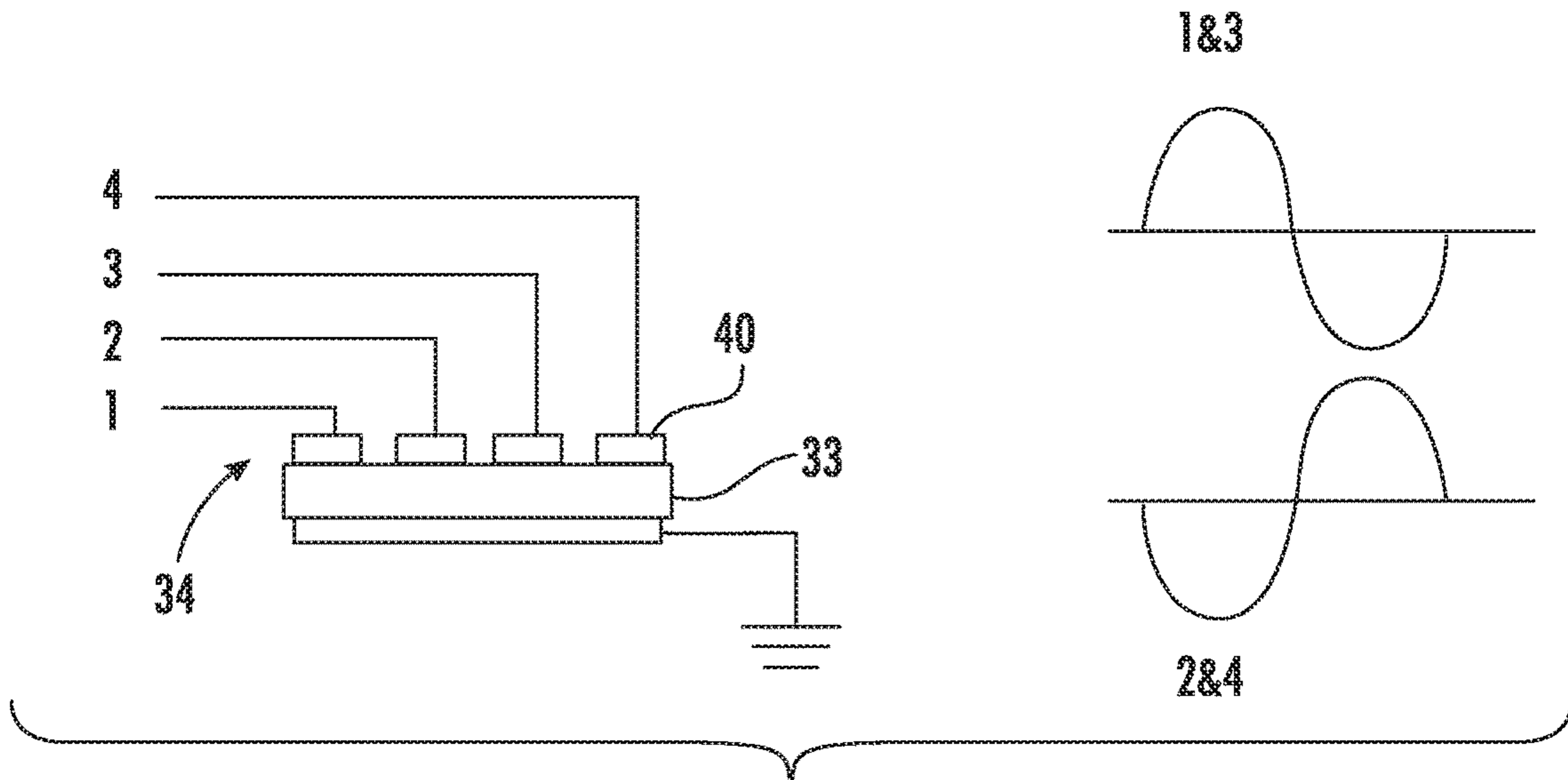

FIG. 2

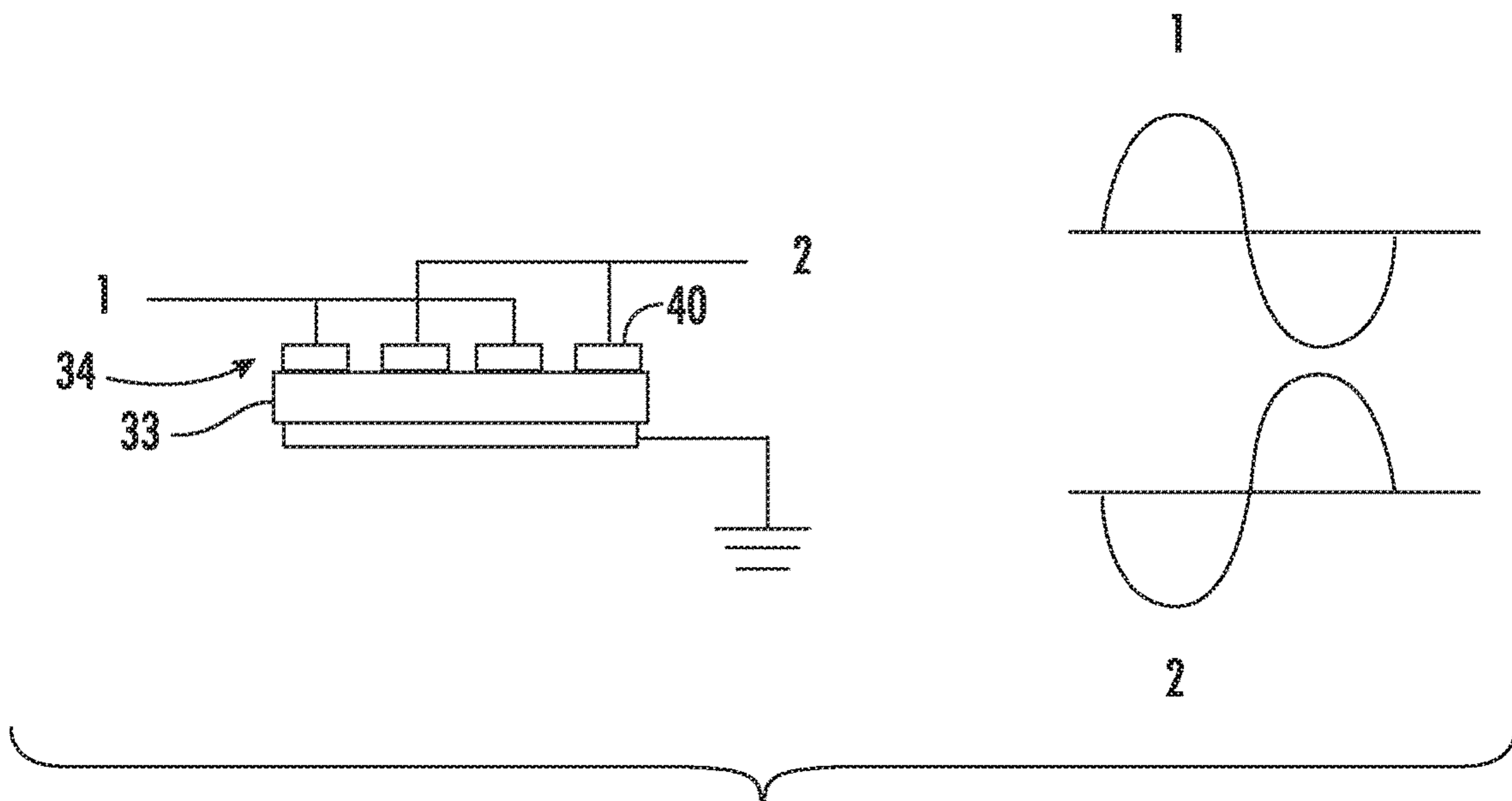

FIG. 3

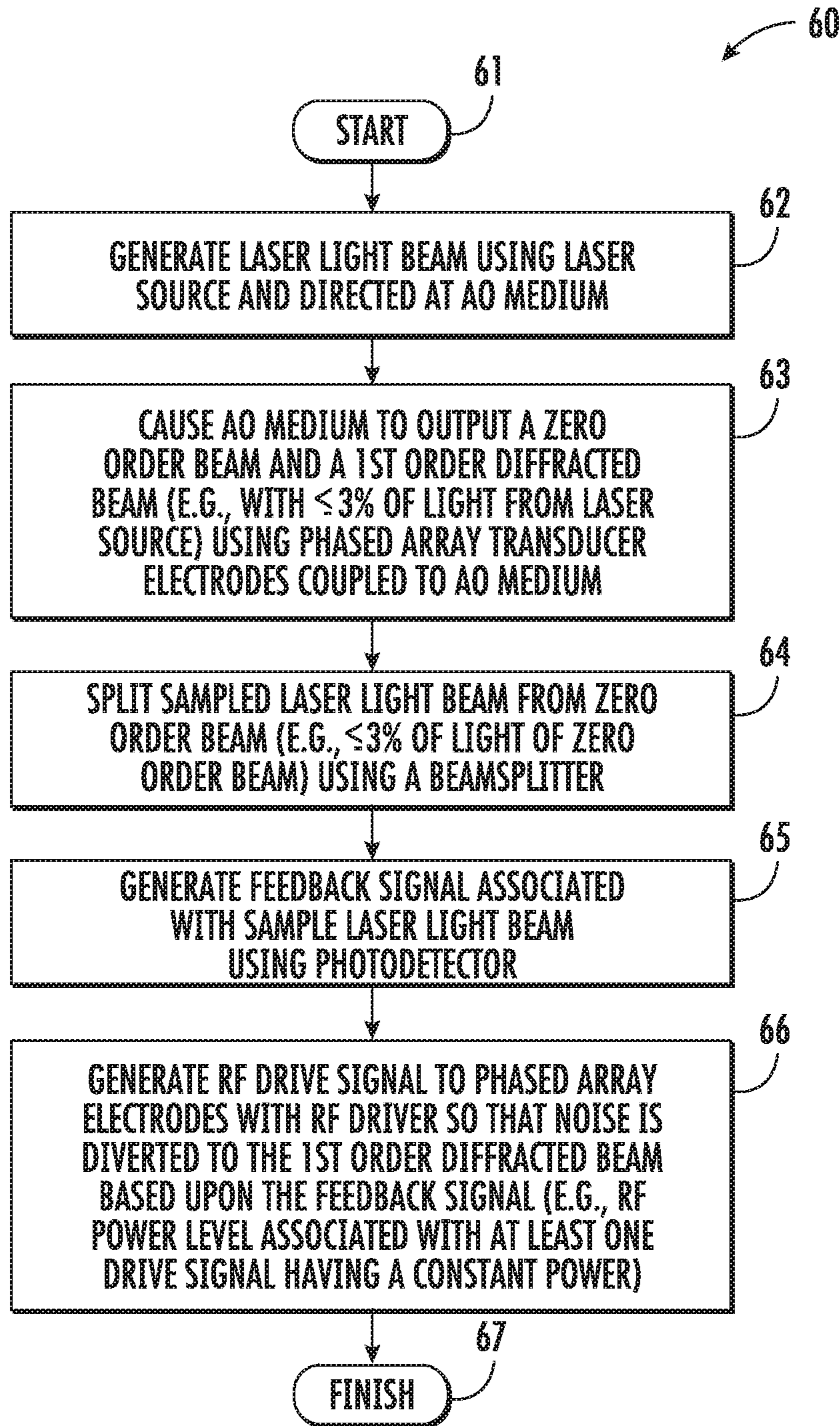

FIG. 4

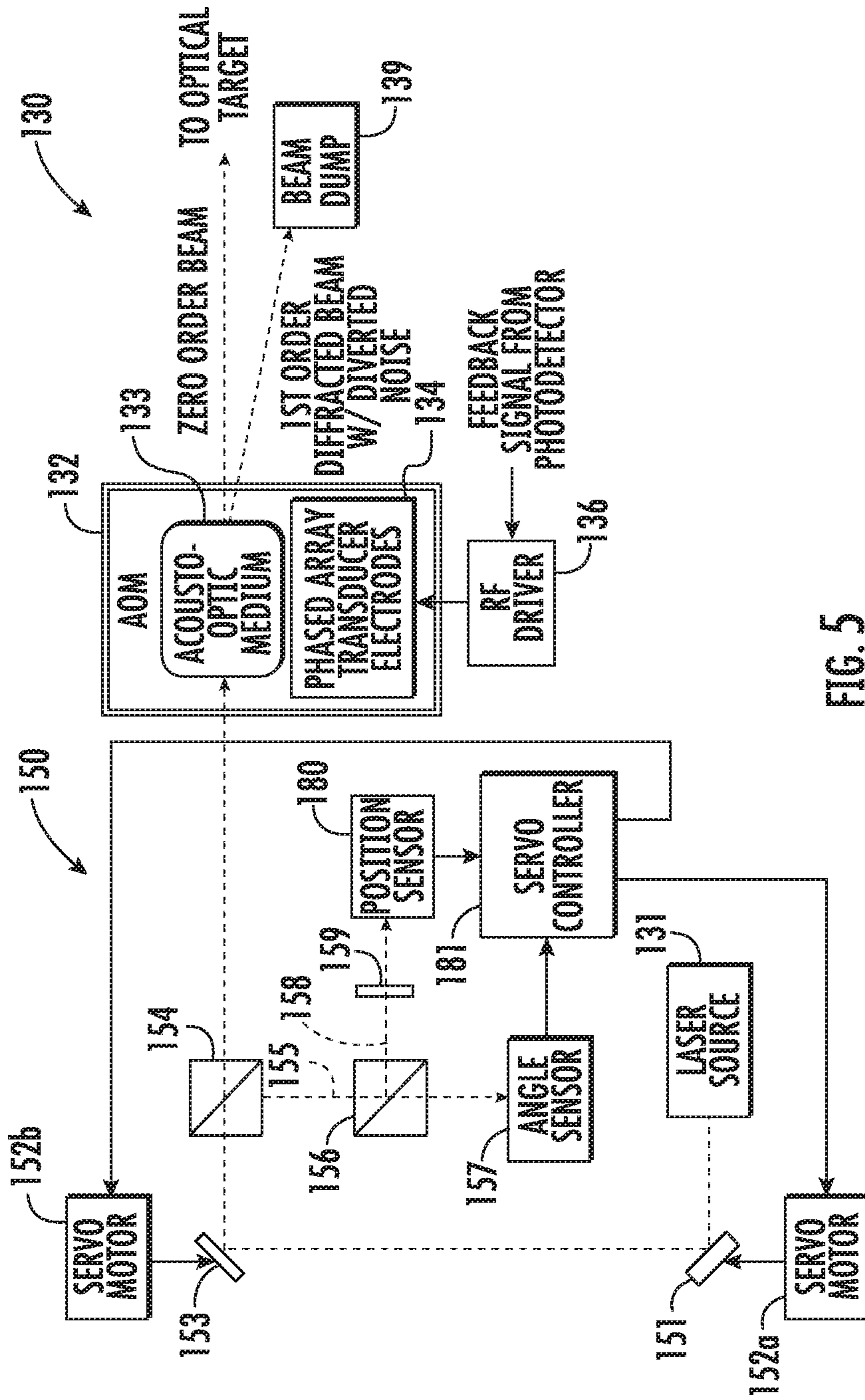

FIG. 5

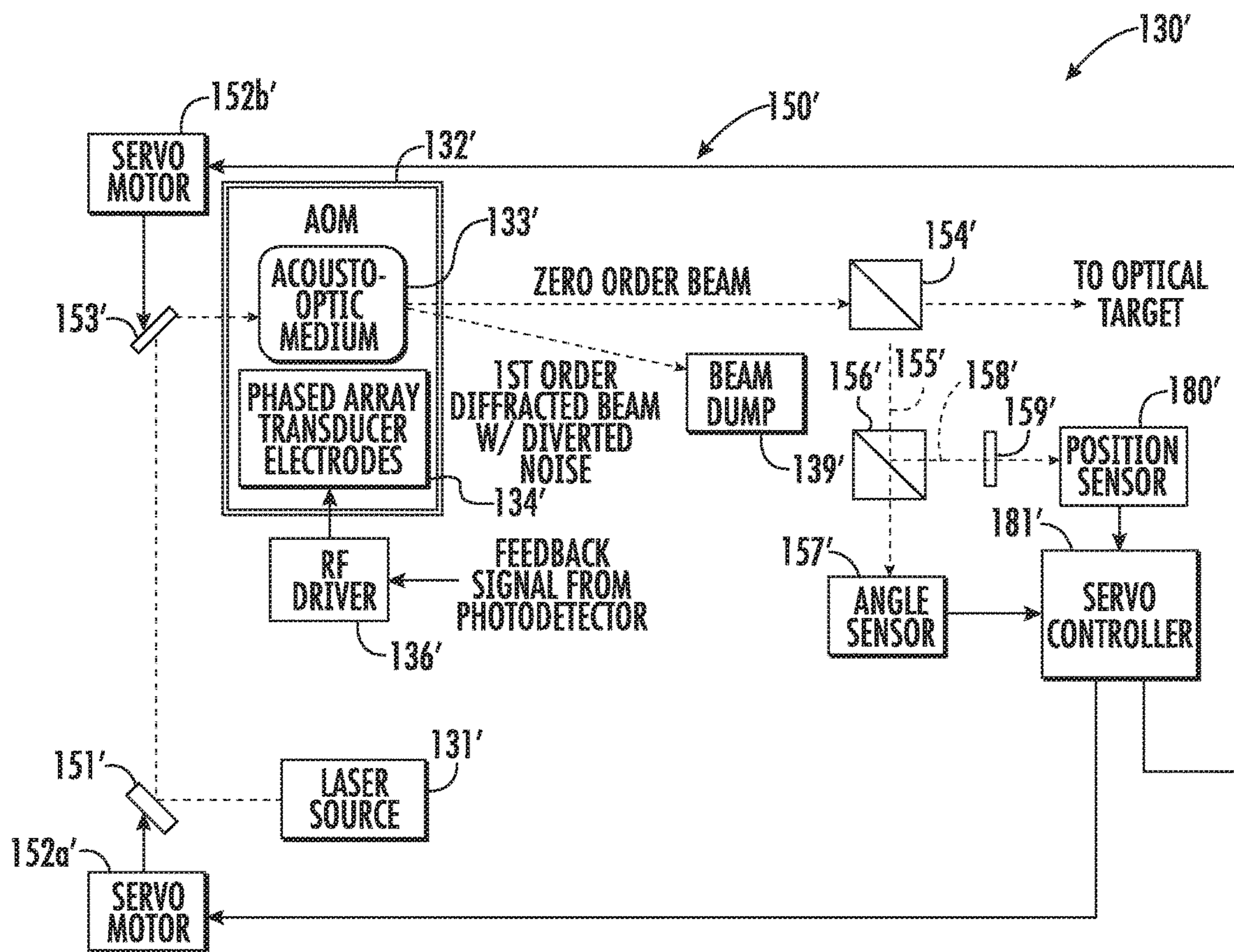

FIG. 6

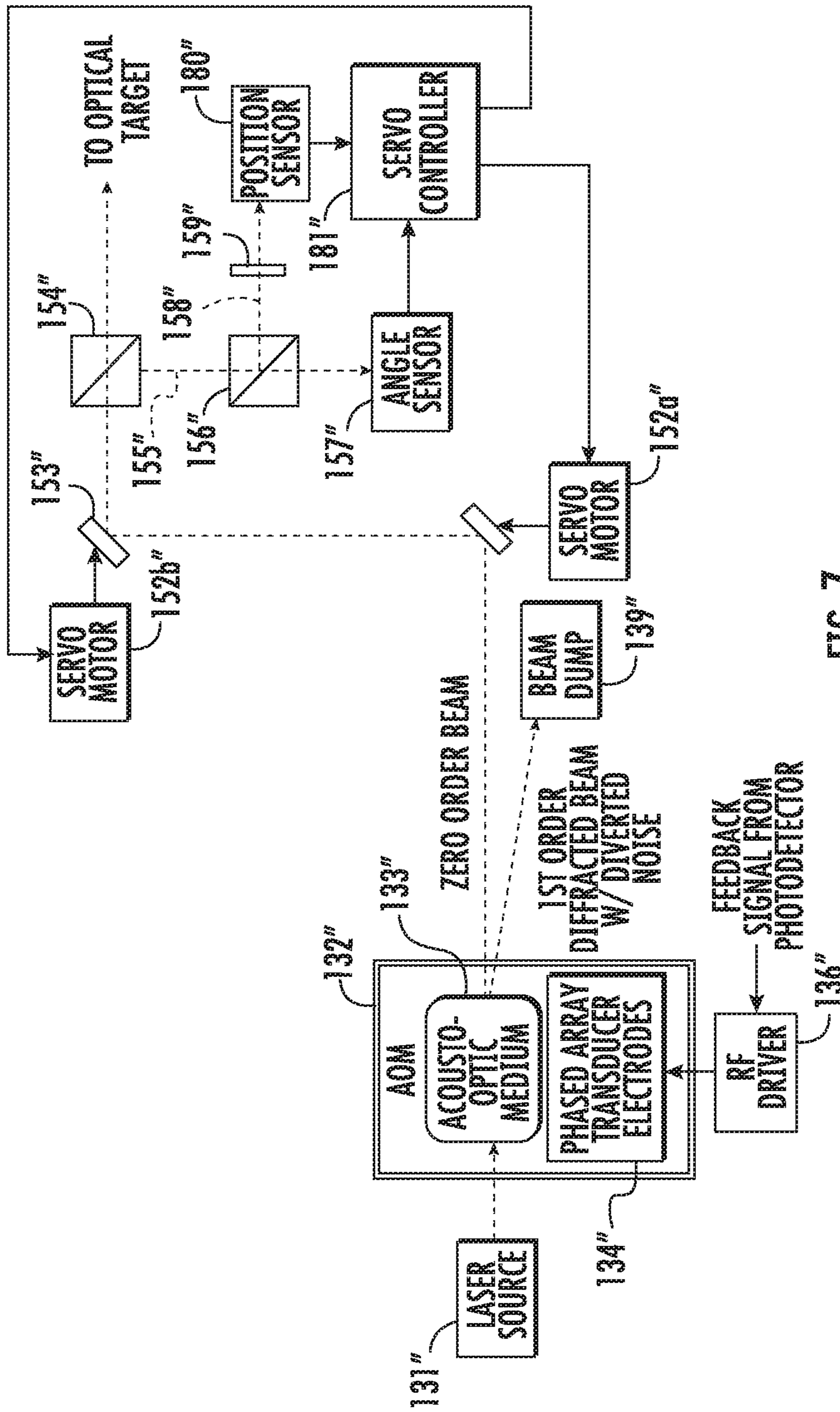

FIG. 7

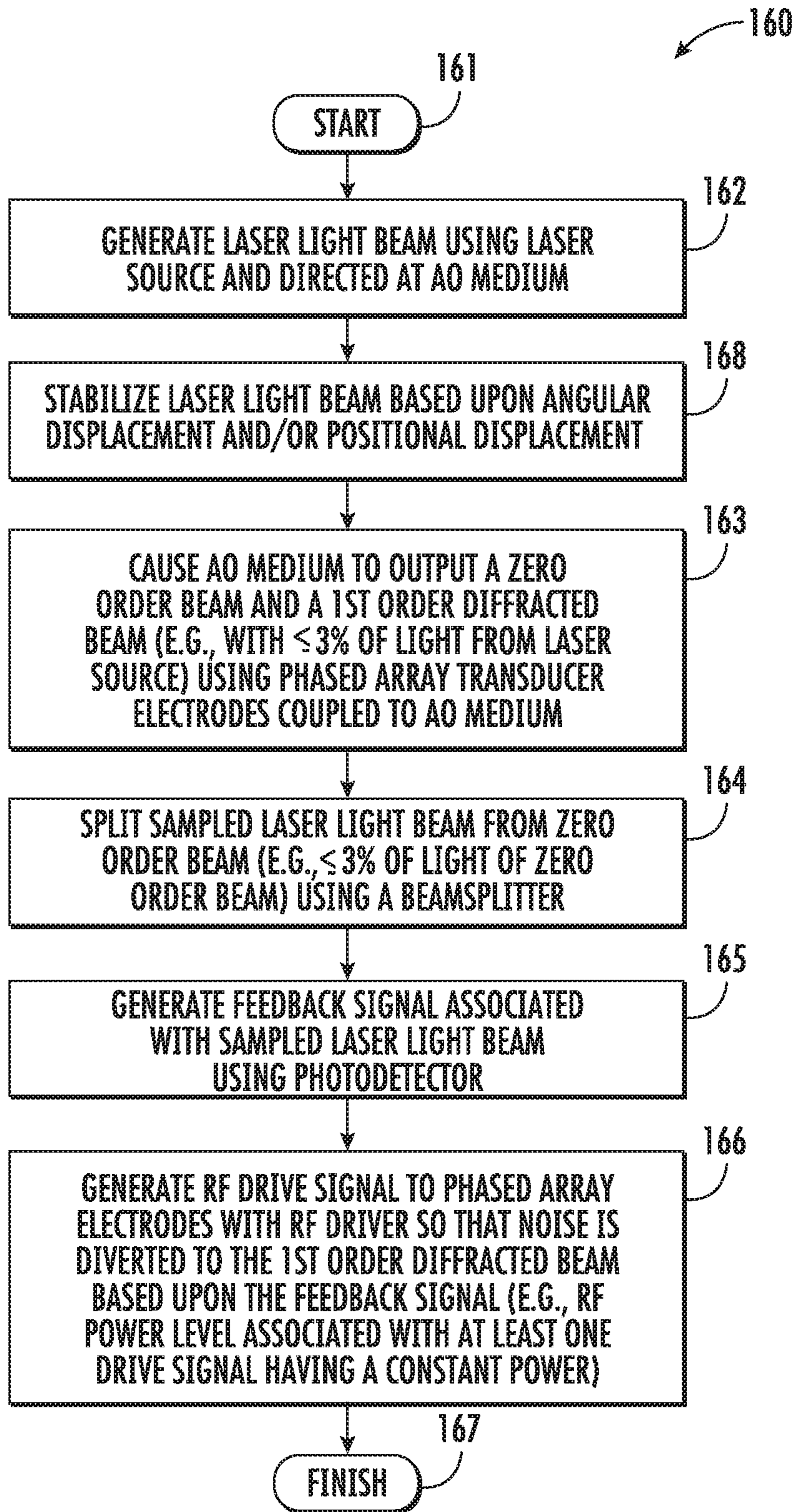

FIG. 8

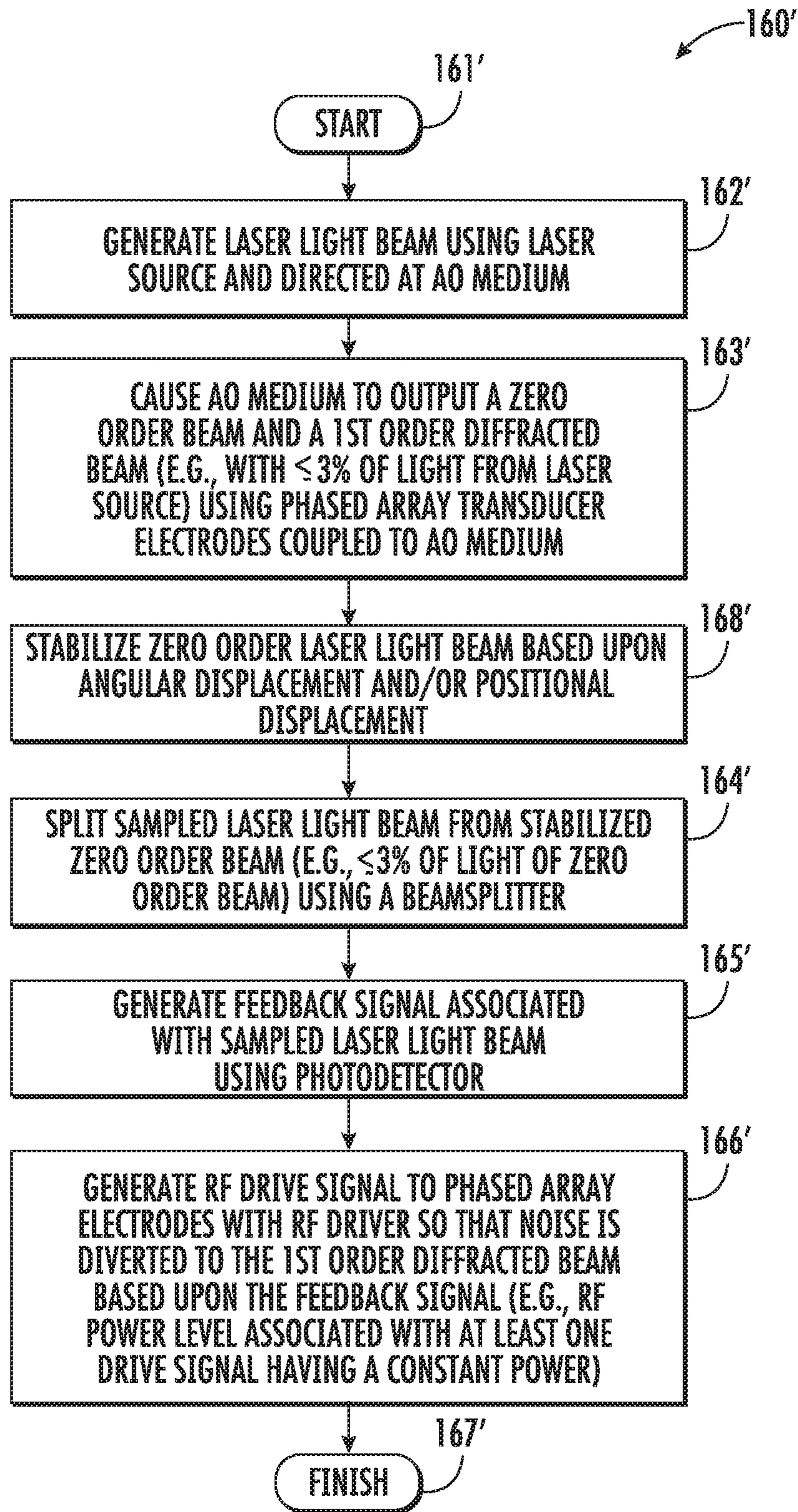

FIG. 9

1

**CONTROL SYSTEM INCLUDING A BEAM
STABILIZER AND A PHASE MODULATION
CAPABLE ACOUSTO-OPTIC MODULATOR
FOR DIVERTING LASER OUTPUT
INTENSITY NOISE TO A FIRST ORDER
LASER LIGHT BEAM AND RELATED
METHODS**

RELATED APPLICATIONS

This application is a continuation in part of application Ser. No. 15/342,372 filed Nov. 3, 2016, which is hereby incorporated herein in its entirety by reference.

TECHNICAL FIELD

The present invention relates to the field of optical devices, and, more particularly, to acousto-optic modulators for lasers and related methods.

BACKGROUND

Acousto-optic modulators, sometimes referred to as Bragg cells, diffract and shift light using sound waves at radio frequency. These devices are often used for Q-switching, signal modulation in telecommunications systems, laser scanning and beam intensity control, frequency shifting, and wavelength filtering in spectroscopy systems. Many other applications lend themselves to using acousto-optic devices.

In such acousto-optic devices, a piezoelectric transducer, sometimes also referred to as an RF transducer, is secured to an acousto-optic bulk medium as a transparent optical material, for example, fused silica, quartz or similar glass material. An electric RF signal oscillates and drives the transducer to vibrate and create sound waves within the transparent medium which affect the properties of an optical field in the medium via the photo elastic effect, in which a modulating strain field of an ultrasonic wave is coupled to an index of refraction for the acousto-optic bulk medium. As a result, the refractive index change in amplitude is proportional to that of sound.

The index of refraction is changed by moving periodic planes of expansion and compression in the acousto-optic bulk material. Incoming light scatters because of the resulting periodic index modulation and interference, similar to Bragg diffraction.

Acousto-optic modulators are preferred in many applications because they are faster than tiltable mirrors and other mechanical devices. The time it takes for the acousto-optic modulator to shift an exiting optical beam is limited to the transit time of the sound wave. The acousto-optic modulators are often used in Q-switches where a laser produces a pulsed output beam at high peak power, typically in the Kilowatt range. This output could be higher than lasers operating a continuous wave (CW) or constant output mode.

Examples of acousto-optic modulator devices and similar acousto-optic systems are disclosed in commonly assigned U.S. Pat. Nos. 4,256,362; 5,923,460; 6,320,989; 6,487,324; 6,538,690; 6,765,709; and 6,870,658, the disclosures of which are hereby incorporated by reference in their entireties.

Some applications using acousto-optic devices modulate the intensity of an optical beam. This modulation may create small deviations in the output angle of the diffracted beam because of the local thermal transients introduced when the RF modulation waveform to the device is turned ON and OFF. These thermal transients may negatively impact the

2

resolution and location of the focused spot, which may be produced. One advantageous approach which may be used to help enhance the resolution of acousto-optic devices is set forth in U.S. Pat. No. 7,538,929 to Wasilousky, which is assigned to the present Applicant and is hereby incorporated herein in its entirety by reference. Wasilousky discloses an acousto-optic modulator which includes an acousto-optic bulk medium and transducer attached to the acousto-optic bulk medium and formed as a linear array of electrodes. A transducer driver is connected to each electrode and is coherently phase driven to alter the angular momentum distribution of an acoustic field and alternately allow and inhibit phase matching between the optical and acoustic field and produce a desired intensity modulation of an optical wavefront.

Despite the existence of such configurations, further advancements in laser systems using acousto-optic modulators may be desirable in certain applications.

SUMMARY

A laser system may include a laser source configured to generate a laser light beam, a beam stabilizer downstream from the laser light source, and an acousto-optic modulator (AOM). The AOM may include an acousto-optic medium configured to receive the laser light beam, and a phased array transducer comprising a plurality of electrodes coupled to the acousto-optic medium and configured to cause the acousto-optic medium to output a zero order laser light beam and a first order diffracted laser light beam. The system may further include a beamsplitter downstream from the AOM and configured to split a sampled laser light beam from the zero order laser light beam, a photodetector configured to receive the sampled laser light beam and generate a feedback signal associated therewith, and a radio frequency (RF) driver configured to generate an RF drive signal to the phased array transducer electrodes so that noise is diverted to the first order diffracted laser light beam based upon the feedback signal.

By way of example, the beam stabilizer may be configured to correct an angular displacement and/or a positional displacement of the laser light beam into the AOM. More particularly, the beam stabilizer may include a position mirror optically aligned with the laser light beam from the laser source, a servo motor configured to move the position mirror, a position sensor configured to measure a positional displacement of the laser light beam, and a servo controller coupled to the servo motor and configured to actuate the servo motor to stabilize the laser light beam based upon the position sensor. Similarly, the beam stabilizer may also include an angle mirror optically aligned with the laser light beam from the laser source, a servo motor configured to move the angle mirror, an angle sensor configured to measure an angular displacement of the laser light beam, and a servo controller coupled to the servo motor and configured to actuate the servo motor to stabilize the laser light beam based upon the angle sensor.

In accordance with another example, the beam stabilizer may include a position mirror optically aligned with the zero order laser light beam from the acousto-optic medium, a servo motor configured to move the position mirror, a position sensor configured to measure a positional displacement of the zero order laser light beam, and a servo controller coupled to the servo motor and configured to actuate the servo motor to stabilize the zero order laser light beam based upon the position sensor. Similarly, beam stabilizer may also include an angle mirror optically aligned

3

with the zero order laser light beam from the acousto-optic medium, a servo motor configured to move the angle mirror, an angle sensor configured to measure an angular displacement of the zero order laser light beam, and a servo controller coupled to the servo motor and configured to actuate the servo motor to stabilize the zero order laser light beam based upon the angle sensor.

Furthermore, the RF driver may be configured to drive alternating electrodes of the phased array transducer electrodes with different phases. Moreover, an RF power level associated with the RF drive signal may have a constant power. In addition, the laser system may also include an ion trap, and the beamsplitter may be configured to direct the zero order laser light beam from the AOM to the ion trap.

A related method may include generating a laser light beam using a laser source, stabilizing the laser light beam using a beam stabilizer downstream from the laser light source, and causing an acousto-optic medium to output a zero order laser light beam from the stabilized laser light beam using a phased array transducer comprising a plurality of electrodes coupled to the acousto-optic medium. The method may further include splitting a sampled laser light beam from the zero order laser light beam using a beamsplitter downstream from the acousto-optic medium, generating a feedback signal associated with the sampled laser light beam using a photodetector, and generating a radio frequency (RF) drive signal for the phased array transducer electrodes with an RF driver so that noise is diverted to the first order diffracted laser light beam based upon the feedback signal.

Another related method may include generating a laser light beam using a laser source, causing an acousto-optic medium to output a zero order laser light beam from the laser light beam using a phased array transducer comprising a plurality of electrodes coupled to the acousto-optic medium, and stabilizing the zero order laser light beam using a beam stabilizer downstream from the acousto-optic medium. The method may further include splitting a sampled laser light beam from the stabilized zero order laser light beam using a beamsplitter downstream from the acousto-optic medium, generating a feedback signal associated with the sampled laser light beam using a photodetector, and generating a radio frequency (RF) drive signal for the phased array transducer electrodes with an RF driver so that noise is diverted to the first order diffracted laser light beam based upon the feedback signal.

BRIEF DESCRIPTION OF THE DRAWINGS

FIG. 1 is a schematic block diagram of a laser system including a phase-capable acousto-optic modulator (AOM) in accordance with an example embodiment.

FIGS. 2 and 3 are schematic circuit diagrams illustrating different electrode connection configurations and associated driving signals therefor which may be used with the systems of FIGS. 1-3.

FIG. 4 is a flow diagram illustrating method aspects associated with the system of FIG. 1.

FIGS. 5-7 are schematic block diagrams of different example implementations of the laser system of FIG. 1 further including respective laser light beam stabilizer configurations.

FIG. 8 is a flow diagram illustrating method aspects associated with the systems of FIGS. 5-6.

4

FIG. 9 is a flow diagram illustrating method aspects associated with the system of FIG. 7.

DETAILED DESCRIPTION OF THE EMBODIMENTS

The present description is made with reference to the accompanying drawings, in which exemplary embodiments are shown. However, many different embodiments may be used, and thus the description should not be construed as limited to the particular embodiments set forth herein. Rather, these embodiments are provided so that this disclosure will be thorough and complete. Like numbers refer to like elements throughout, and prime and multiple prime notation are used to indicate similar elements or steps in different embodiments.

By way of background, excessive noise levels from laser sources in optical illumination systems generate instabilities and errors. In particular, systems that manipulate the quantum states of particles, atoms and electrons, typically require extreme stability. Beam pointing errors correlate to noise in quantum state manipulation systems. Moreover, beam pointing stability due to thermal transients in the bulk material of active acousto-optic devices in an optical illumination system affect many applications, but especially those designed for quantum state illumination.

Referring initially to FIGS. 1 and 4, a laser system 30 and associated method aspects which may provide enhanced stability and noise reduction are first described. Beginning at Block 61 of the flow diagram 60, the laser system 30 illustratively includes a laser source 31 configured to generate a laser light beam, at Block 62. In accordance with one example embodiment, a Paladin Advanced 355 nm mode locked UV laser source from Coherent, Inc. of Santa Clara, Calif. may be used, although other suitable laser sources may also be used in different embodiments. The system 30 further illustratively includes an acousto-optic modulator (AOM) 32. The AOM illustratively includes an acousto-optic medium 33 configured to receive the laser light beam from the laser source 31, and a phased array of electrodes 34 coupled to the acousto-optic medium. The acousto-optic medium 33 may include a piezoelectric transducer and bulk acousto-optic medium (e.g., silica, quartz, glass, etc.), as discussed above. The phased array of electrodes 34 are configured to cause the acousto-optic medium 33 to output a zero order laser light beam to an optical target 38, and a first order diffracted laser light beam, at Block 63, as will be discussed further below.

The system further illustratively includes a beamsplitter 35 downstream from the AOM 32 which is configured to split a sampled laser light beam from the zero order laser light beam, at Block 64. The beamsplitter 35 need only divert a small portion of light from the zero order laser light beam into the sampled laser light beam (e.g., 3%) to provide adequate feedback to a radio frequency (RF) driver 36 for driving the phase array of electrodes 34. More particularly, a photodetector 37 is configured to receive the sampled laser light beam and generate an electrical feedback signal for the RF driver 36 based upon the sampled laser light beam. As such, the RF driver 36 is able to generate one or more RF drive signals to the phased array of electrodes 34 to generate the zero order beam and the first order diffracted beam accordingly, which illustratively concludes the method of FIG. 4 (Block 67).

In particular, the RF driver 36 drives the phased array of electrodes 34 such that noise measured from the feedback signal is diverted to the first order diffracted laser light beam,

which may be directed to a beam dump **39** (or simply away from the optical target **38**). This advantageously provides noise cancellation by diffracting a relatively small amount of light from the zero order beam (e.g., <3%) into the first order diffracted beam by changing the phase of the RF drive signal to alternating electrode elements of the phased array of electrodes **34**. In particular, the feedback signal is inverted and sent to the phase modulation capable AOM **32** to subtract and correct for the inherent noise in the laser.

This may be done while the RF power applied to the acousto-optic medium **33** remains essentially constant which helps to eliminate beam pointing errors which may otherwise be associated with varying thermal transients due to changing RF power levels, as may be experienced with typical amplitude modulation AOMs, for example. Stated alternatively, by only effecting the phase of the RF drive signal to the N element phased array electrode pattern on the AOM and leaving the RF power level essentially constant, this advantageously reduces the laser intensity noise appearing on the zero order beam while still retaining a positionally stable beam.

More particularly, referring additionally to FIGS. **2** and **3**, two example configurations for driving alternating electrodes **40** of the phased array of electrodes **34** with different phases to provide the zero and first order beam configuration described above are now described. In the first configuration (FIG. **2**), the first and third driving signals (shown on the right hand side of FIG. **2**) provided to corresponding odd numbered electrodes are 180° out of phase with the second and fourth driving signals provided to corresponding even numbered electrodes. In the second configuration (FIG. **3**), first and second drive signals are respectively connected to odd and even electrodes in an interdigitated fashion as shown, and as before these drive signals are 180° out of phase to one another. In this way, directly adjacent electrodes are driven at opposite phases to one another. However, it should be noted that the RF drive signals need not always be 180° out of phase, i.e., they may be somewhere between 0° and 180° to vary the level of phase matching occurring in the AO diffraction process, thereby selectively altering the amount of light directed from the zero order beam into the first order beam.

The system **30** accordingly combines intensity modulation via RF-phase variation on a phased array transducer with active optical feedback to accomplish noise cancellation in an optical illumination system. Moreover, performing phase modulation by flipping the phase of alternating elements of a multi-element phased array has inherently better pointing stability because the RF power applied to the device remains essentially constant, as noted above. Further, applying this to the zero order beam allows the RF power to remain low, reducing the potential of thermal gradients and thermal transients.

The system **30** may accordingly provide advantages with respect to numerous different types of optical targets. By way of example, in one configuration the optical target **38** may be an ion trap, such as in a quantum computing device. In accordance with another example, the optical target **38** may be a semiconductor workpiece to perform photolithographic patterning of a photoresist layer, for example. In still another example, the optical target **38** may be a micromachining workpiece. It should be noted that the laser system **30** may be used with other optical targets in different embodiments as well.

Other example systems in which the above-described stability and noise reduction techniques may be used are set forth in the following co-pending applications: U.S. patent

application Ser. No. 15/342,357 filed Nov. 3, 2016, entitled MULTI-CHANNEL LASER SYSTEM INCLUDING AN ACOUSTO-OPTIC MODULATOR (AOM) AND RELATED METHODS; and U.S. patent application Ser. No. 15/342,350 filed Nov. 3, 2016, entitled MULTI-CHANNEL ACOUSTO-OPTIC MODULATOR (AOM) AND RELATED METHODS. Both of these applications are assigned to the present Applicant Harris Corporation and are hereby incorporated herein in their entireties by reference.

Turning now to FIGS. **5-6** and **8**, another example implementation of a laser system **130** illustratively includes a beam stabilizer **150** to help address “wandering” of the laser light beam from the laser source **131** which tends to occur over time. In the illustrated example, the laser source **131**, AOM **132**, acousto-optic medium **133**, phased array transducer electrodes **134**, RF driver **136**, and beam dump **139** are similar to the elements **31**, **32**, **33**, **34**, **36**, and **39** described above, respectively. Furthermore, it should be noted that counterparts of the beamsplitter **35**, photodetector **37**, and optical targets would also be present in the system **130** as described above and shown in FIG. **1**, but they are omitted from FIGS. **5-7** for clarity of illustration of the beam stabilizer components.

In the present example, the beam stabilizer **150** is configured to correct an angular displacement and a positional displacement of the laser light beam from the laser source **131** (although both positional and angular displacement need not be corrected in all embodiments). More particularly, the beam stabilizer **150** illustratively includes a position mirror **151** optically aligned with the laser light beam from the laser source **131**, a servo motor **152a** configured to move the position mirror, an angle mirror **153** optically aligned with the position mirror to redirect the laser light beam therefrom to the acousto-optic medium **133**, and a servo motor **152b** configured to move the angle mirror.

Furthermore, a beamsplitter **154** is positioned in the optical path between the angle mirror **153** and the acousto-optic medium **133** downstream from the angle mirror and configured to split a sampled laser light beam **155** from the original laser light beam from the laser source **131**, and direct this sampled laser light beam to an angle sensor **157**. Furthermore, in the illustrated example another beamsplitter **156** is positioned in the optical path of the sampled laser light beam **155** between the beamsplitter **154** and the angle sensor **157** to split off another sampled laser light beam **158** which is directed through a lens **159** to image the angle mirror to a position sensor **180**. The angle sensor **157** is configured to measure an angular displacement of the laser light beam from the laser source, and the position sensor **180** is configured to measure a positional displacement of the laser light beam from the laser source **131**. These measurements are provided to a servo controller **181**, which in turn controls or actuates the servo motors **152a**, **152b** to correct the positional and angular displacements caused by drift or wandering of the laser light beam at the laser source **131**.

In accordance with another example of the system **130'** now described with reference to FIG. **6**, portions of the beam stabilizer **150'** are positioned both upstream and downstream from the AOM **132'**, rather than all upstream as in the system **130**. In this example, the position mirror **151'** and angle mirror **153'** remain upstream from the AOM **132'**, but the beamsplitters **154'**, **156'**, angle sensor **157'**, and position sensor **180'**, are downstream of the AOM, meaning they are splitting/measuring the zero order beam exiting the acousto-optic medium **133'**, as opposed to the laser light beam from the laser source **131'** as in the system **130**. Nevertheless, the servo controller **181'** still causes the servo motors **152a'**,

152b' to adjust the position mirror **151'** and angle mirror **153'** to perform beam correction to the laser light beam exiting the laser source **131'** as noted above.

Still another example implementation is now described with reference to FIG. 7. In this embodiment, the beam stabilizer **150"** is downstream from the AOM **132"**, including the position mirror **151"** and the angle mirror **153"**. As such, the mirrors **151"**, **153"** are directing, and the beam splitters **154"**, **155"**, angle sensor **157"**, and position sensor **180"**, are splitting/measuring, the zero order beam exiting the acousto-optic medium **133"**. Moreover, the corrections performed by the servo motor(s) **152"** and portion mirror **151"** are to the zero order beam, not the laser light beam from the laser source **131"** as in the preceding two embodiments. All of the systems **130**, **130'**, **130"** may advantageously be used to correct positional and/or angular displacement, and the choice of which one to implement may depend on the particular application, space constraints, and other considerations that will be appreciated by those skilled in the art.

Related method aspects corresponding to the systems **130**, **130'** are now described with reference to the flow diagram **160** of FIG. 8. In the illustrated example, the steps illustrated at Blocks **161-167** are similar to those discussed above with reference to Blocks **61-67** of FIG. 4 above. However, the illustrated method further includes a step of stabilizing the laser light beam from the laser light source **131**, **131'** using the beam stabilizer **150** or **150'** based upon angular displacement and/or positional displacement, at Block **168**, as discussed further above.

Still further method aspects corresponding to the system **130"** are now described with reference to the flow diagram **160'** of FIG. 9. In the illustrated example, the steps illustrated at Blocks **161'-167'** are similar to those discussed above with reference to Blocks **61-67** of FIG. 4 above. However, the illustrated method further includes a step of stabilizing the zero order laser light beam from the acousto-optic medium **133"** using the beam stabilizer **150"** based upon angular displacement and/or positional displacement, at Block **168'**, as discussed further above.

Many modifications and other embodiments will come to the mind of one skilled in the art having the benefit of the teachings presented in the foregoing descriptions and the associated drawings. Therefore, it is understood that the disclosure is not to be limited to the specific embodiments disclosed, and that modifications and embodiments are intended to be included within the scope of the appended claims.

That which is claimed is:

1. A laser system comprising:

a laser source configured to generate a laser light beam;
a beam stabilizer downstream from the laser light source;
an acousto-optic modulator (AOM) comprising

an acousto-optic medium configured to receive the laser light beam, and

a phased array transducer comprising a plurality of electrodes coupled to the acousto-optic medium and configured to cause the acousto-optic medium to output a zero order laser light beam and a first order diffracted laser light beam;

a beamsplitter downstream from the AOM and configured to split a sampled laser light beam from the zero order laser light beam;

a photodetector configured to receive the sampled laser light beam and generate a feedback signal associated therewith; and

a radio frequency (RF) driver configured to generate an RF drive signal to the phased array transducer electrodes so that noise is diverted to the first order diffracted laser light beam based upon the feedback signal.

2. The laser system of claim **1** wherein the beam stabilizer is configured to correct a positional displacement of the laser light beam.

3. The laser system of claim **1** wherein the beam stabilizer comprises:

a position mirror optically aligned with the laser light beam from the laser source;

a servo motor configured to move the position mirror;

a position sensor configured to measure a positional displacement of the laser light beam; and

a servo controller coupled to the servo motor and configured to actuate the servo motor to stabilize the laser light beam based upon the position sensor.

4. The laser system of claim **1** wherein the beam stabilizer comprises:

a position mirror optically aligned with the zero order laser light beam from the acousto-optic medium;

a servo motor configured to move the position mirror;

a position sensor configured to measure a positional displacement of the zero order laser light beam; and

a servo controller coupled to the servo motor and configured to actuate the servo motor to stabilize the zero order laser light beam based upon the position sensor.

5. The laser system of claim **1** wherein the beam stabilizer is configured to correct an angular displacement of the laser light beam.

6. The laser system of claim **1** wherein the beam stabilizer comprises:

an angle mirror optically aligned with the laser light beam from the laser source;

a servo motor configured to move the angle mirror;

an angle sensor configured to measure an angular displacement of the laser light beam; and

a servo controller coupled to the servo motor and configured to actuate the servo motor to stabilize the laser light beam based upon the angle sensor.

7. The laser system of claim **1** wherein the beam stabilizer comprises:

an angle mirror optically aligned with the zero order laser light beam from the acousto-optic medium;

a servo motor configured to move the angle mirror;

an angle sensor configured to measure an angular displacement of the zero order laser light beam; and

a servo controller coupled to the servo motor and configured to actuate the servo motor to stabilize the zero order laser light beam based upon the angle sensor.

8. The laser system of claim **1** wherein the RF driver is configured to drive alternating electrodes of the phased array transducer electrodes with different phases.

9. The laser system of claim **1** wherein an RF power level associated with the RF drive signal has a constant power.

10. The laser system of claim **1** further comprising an ion trap, and wherein the beamsplitter is configured to direct the zero order laser light beam from the AOM to the ion trap.

11. A laser system comprising:

a laser source configured to generate a laser light beam;

a beam stabilizer downstream from the laser light source and configured to correct at least one of an angular displacement and a positional displacement of the laser light beam;

an acousto-optic modulator (AOM) comprising
 an acousto-optic medium configured to receive the
 laser light beam from the beam stabilizer, and
 a phased array transducer comprising a plurality of
 electrodes coupled to the acousto-optic medium and
 configured to cause the acousto-optic medium to
 output a zero order laser light beam and a first order
 diffracted laser light beam;
 a beamsplitter downstream from the AOM and configured
 to split a sampled laser light beam from the zero order
 laser light beam;
 a photodetector configured to receive the sampled laser
 light beam and generate a feedback signal associated
 therewith; and
 a radio frequency (RF) driver configured to generate an
 RF drive signal to the phased array transducer elec-
 trodes so that noise is diverted to the first order dif-
 fracted laser light beam based upon the feedback sig-
 nal.

12. The laser system of claim **11** wherein the beam
 stabilizer comprises:
 a position mirror optically aligned with the laser light
 beam from the laser source;
 a servo motor configured to move the position mirror;
 a position sensor configured to measure a positional
 displacement of the laser light beam; and
 a servo controller coupled to the servo motor and config-
 ured to actuate the servo motor to stabilize the laser
 light beam based upon the position sensor.

13. The laser system of claim **11** wherein the beam
 stabilizer comprises:
 an angle mirror optically aligned with the laser light beam
 from the laser source;
 a servo motor configured to move the angle mirror;
 an angle sensor configured to measure an angular dis-
 placement of the laser light beam; and
 a servo controller coupled to the servo motor and config-
 ured to actuate the servo motor to stabilize the laser
 light beam based upon the angle sensor.

14. The laser system of claim **11** wherein the RF driver is
 configured to drive alternating electrodes of the phased array
 transducer electrodes with different phases.

15. The laser system of claim **11** further comprising an ion
 trap, and wherein the beamsplitter is configured to direct the
 zero order laser light beam from the AOM to the ion trap.

16. A method comprising:
 generating a laser light beam using a laser source;
 stabilizing the laser light beam using a beam stabilizer
 downstream from the laser light source;
 causing an acousto-optic medium to output a zero order
 laser light beam from the stabilized laser light beam
 using a phased array transducer comprising a plurality
 of electrodes coupled to the acousto-optic medium;
 splitting a sampled laser light beam from the zero order
 laser light beam using a beamsplitter downstream from
 the acousto-optic medium;
 generating a feedback signal associated with the sampled
 laser light beam using a photodetector; and
 generating a radio frequency (RF) drive signal for the
 phased array transducer electrodes with an RF driver so
 that noise is diverted to the first order diffracted laser
 light beam based upon the feedback signal.

17. The method of claim **16** wherein stabilizing comprises
 stabilizing an angular displacement of the laser light beam.

18. The method of claim **16** wherein stabilizing comprises
 stabilizing a positional displacement of the laser light beam.

19. The method of claim **16** wherein causing comprises
 driving alternating electrodes of the phased array transducer
 electrodes with different phases.

20. A method comprising:
 generating a laser light beam using a laser source;
 causing an acousto-optic medium to output a zero order
 laser light beam from the laser light beam using a
 phased array transducer comprising a plurality of elec-
 trodes coupled to the acousto-optic medium;
 stabilizing the zero order laser light beam using a beam
 stabilizer downstream from the acousto-optic medium;
 splitting a sampled laser light beam from the stabilized
 zero order laser light beam using a beamsplitter down-
 stream from the acousto-optic medium;
 generating a feedback signal associated with the sampled
 laser light beam using a photodetector; and
 generating a radio frequency (RF) drive signal for the
 phased array transducer electrodes with an RF driver so
 that noise is diverted to the first order diffracted laser
 light beam based upon the feedback signal.

21. The method of claim **20** wherein stabilizing comprises
 stabilizing an angular displacement of the laser light beam.

22. The method of claim **20** wherein stabilizing comprises
 stabilizing a positional displacement of the laser light beam.

23. The method of claim **20** wherein causing comprises
 driving alternating electrodes of the phased array transducer
 electrodes with different phases.

* * * * *