

US010457530B2

(12) **United States Patent**
Pech et al.

(10) **Patent No.:** **US 10,457,530 B2**
(45) **Date of Patent:** ***Oct. 29, 2019**

(54) **LIFT CRANE WITH MOVEABLE COUNTERWEIGHT**

(56) **References Cited**

(71) Applicant: **Manitowoc Cranes, LLC**, Manitowoc, WI (US)

U.S. PATENT DOCUMENTS

496,428 A 5/1893 Morgan
524,619 A 8/1894 Sturm

(72) Inventors: **David J. Pech**, Manitowoc, WI (US);
Joseph R. Rucinski, Manitowoc, WI (US)

(Continued)

FOREIGN PATENT DOCUMENTS

(73) Assignee: **Manitowoc Cranes, LLC**, Manitowoc, WI (US)

AT 201 812 6/2001
CN 86 202 467 U 10/1987

(Continued)

(*) Notice: Subject to any disclaimer, the term of this patent is extended or adjusted under 35 U.S.C. 154(b) by 159 days.

OTHER PUBLICATIONS

This patent is subject to a terminal disclaimer.

Sections of brochure entitled "Demag CC 8800, 1250t," Demag Mobile Cranes GmbH & Co.KG, 9 pages (cover page, pp. 6, 7, 10, 11, 13, 62 and 63, back page), undated, but prior to Oct. 27, 2006.

(Continued)

(21) Appl. No.: **13/712,774**

Primary Examiner — Sang K Kim

(22) Filed: **Dec. 12, 2012**

Assistant Examiner — Nathaniel L Adams

(65) **Prior Publication Data**

US 2013/0112642 A1 May 9, 2013

(74) *Attorney, Agent, or Firm* — Ramey & Schwaller, LLP; Craig Buschmann

Related U.S. Application Data

(63) Continuation of application No. 12/847,902, filed on Jul. 30, 2010, now Pat. No. 9,278,834.

(Continued)

(57) **ABSTRACT**

(51) **Int. Cl.**

B66C 23/76 (2006.01)

B66C 23/82 (2006.01)

A lift crane includes a carbody; moveable ground engaging members; a rotating bed rotatably connected to the carbody; and a boom pivotally mounted on the rotating bed. The crane is configured for assembly in at least two configurations. In the first configuration, the crane further includes a live mast; a first counterweight support frame; and a first movable counterweight unit moveably connected to and supported by the first counterweight support frame. In the second configuration, the crane further includes a lattice mast; a second counterweight support frame; a moveable counterweight support beam coupled to the second counterweight support frame and operable to move relative to the second counterweight support frame; and a second moveable counterweight unit moveably connected to the moveable counterweight support beam.

(52) **U.S. Cl.**

CPC **B66C 23/76** (2013.01); **B66C 23/82** (2013.01)

(58) **Field of Classification Search**

CPC B66C 23/53; B66C 23/72; B66C 23/74; B66C 23/76; B66C 2700/0314; B66C 2700/0392; B66C 23/36

(Continued)

18 Claims, 36 Drawing Sheets

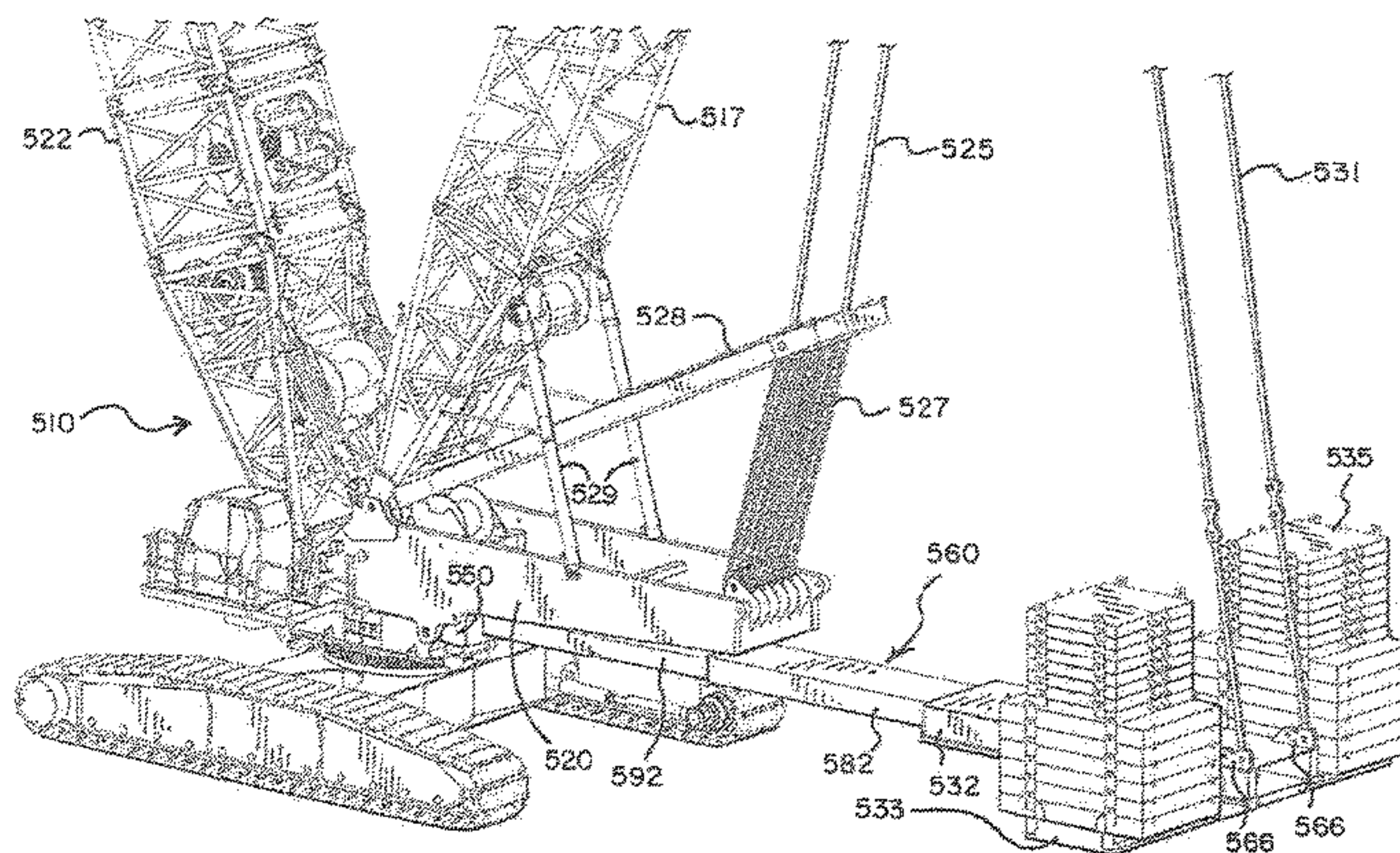
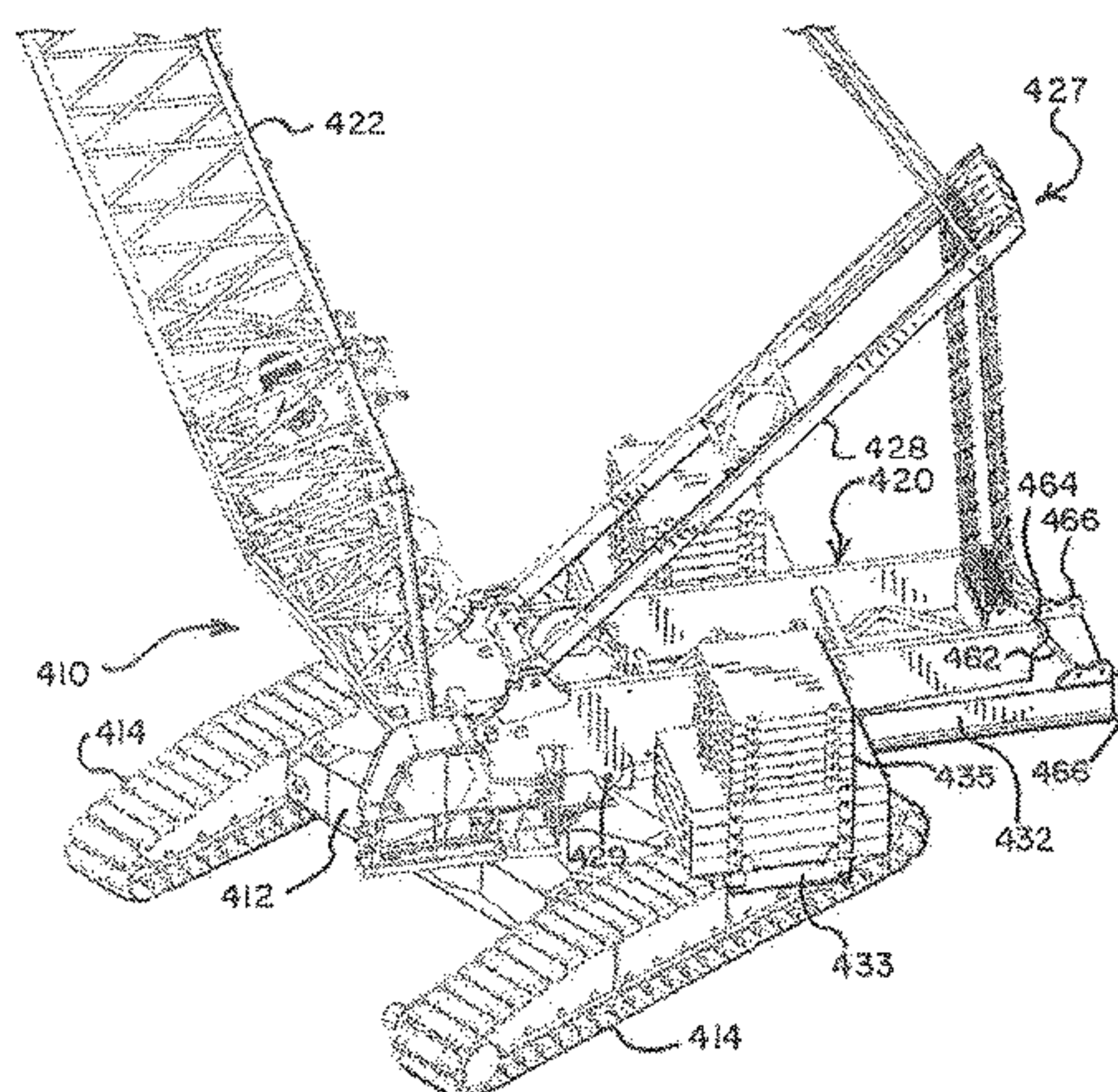

Related U.S. Application Data

- (60) Provisional application No. 61/231,884, filed on Aug. 6, 2009, provisional application No. 61/365,217, filed on Jul. 16, 2010.
- (58) **Field of Classification Search**
USPC 212/178, 195–198, 279, 301
See application file for complete search history.

(56) **References Cited**

U.S. PATENT DOCUMENTS

733,128	A	7/1903	Bennett et al.	
752,248	A	2/1904	Nickerson	
970,773	A	9/1910	Wylie	
1,756,106	A	4/1930	Swenson	
1,877,373	A	9/1932	Cohen-Venezian	
2,082,889	A	6/1937	Hight	
2,368,268	A *	1/1945	Spiegel 212/279	
2,526,613	A	10/1950	Tanguy	
3,202,299	A	8/1965	De Cuir	
3,209,920	A	10/1965	De Cuir	
3,547,278	A	12/1970	Taylor	
3,572,517	A	3/1971	Liebherr et al.	
3,713,544	A	1/1973	Wallace et al.	
3,836,010	A *	9/1974	Lampson 212/195	
3,842,984	A	10/1974	Brown et al.	
3,921,815	A	11/1975	Brown et al.	
3,924,753	A	12/1975	Lamer et al.	
3,930,583	A	1/1976	Jouffray	
3,945,518	A	3/1976	Inoue	
3,955,684	A	5/1976	Novotny	
3,955,844	A	5/1976	de Castella et al.	
4,017,109	A	4/1977	Belinsky	
4,081,081	A	3/1978	Morrow, Sr. et al.	
4,168,781	A	9/1979	Bryan, Jr.	
4,172,529	A	10/1979	Bryan, Jr.	
4,181,231	A	1/1980	Morrissey et al.	
4,186,585	A	2/1980	Passoni et al.	
4,204,603	A	5/1980	Ducreuzet	
4,258,852	A	3/1981	Juergens	
4,279,348	A	7/1981	Harper et al.	
4,280,627	A	7/1981	Becker	
4,349,115	A	9/1982	Lampson	
4,381,060	A *	4/1983	Morrow et al. 212/195	
4,394,911	A	7/1983	Wittman et al.	
4,446,976	A *	5/1984	Imerman et al. 212/304	
4,508,232	A	4/1985	Lampson	
4,537,317	A	8/1985	Jensen	
4,540,097	A	9/1985	Wadsworth et al.	
4,557,390	A	12/1985	Mick	
4,614,275	A	9/1986	Zenno	
4,711,358	A	12/1987	Konishi	
4,729,486	A *	3/1988	Petzold et al. 212/302	
4,867,321	A	9/1989	Montgon	
4,901,982	A	2/1990	Harvard et al.	
4,907,768	A	3/1990	Masseron	
4,953,722	A	9/1990	Becker et al.	
4,995,518	A	2/1991	McGhie	
5,005,714	A	4/1991	Kröll et al.	
5,035,337	A	7/1991	Juergens	
5,156,215	A	10/1992	Jensen	
5,203,837	A	4/1993	Madic et al.	
5,222,613	A	6/1993	McGhie	
5,332,110	A	7/1994	Forsyth	
5,522,515	A	6/1996	Pech et al.	
5,586,667	A	12/1996	Landry	
5,598,935	A *	2/1997	Harrison et al. 212/197	
5,833,268	A	11/1998	Aldrovandi	
5,836,205	A	11/1998	Meyer	
5,854,988	A	12/1998	Davidson et al.	
5,941,401	A	8/1999	Petzold et al.	
6,065,620	A	5/2000	McGhie	
6,089,388	A	7/2000	Willim	
6,098,823	A *	8/2000	Yahiaoui 212/197	
6,109,463	A	8/2000	Cullity	
6,283,315	B1 *	9/2001	Willim et al. 212/196	

6,341,665	B1	1/2002	Zhou et al.	
6,360,905	B1	3/2002	Frommelt et al.	
6,474,485	B1	11/2002	Yokoyama	
6,474,487	B1	11/2002	Kretschmer	
6,481,202	B1	11/2002	Zuehlke et al.	
6,508,372	B1	1/2003	Lamphen et al.	
6,516,961	B1	2/2003	Knecht et al.	
6,568,547	B1 *	5/2003	Kretschmer et al. 212/196	
6,588,521	B1	7/2003	Porubcansky et al.	
6,631,814	B2	10/2003	Willim	
6,814,164	B2	11/2004	Mills et al.	
6,934,616	B2	8/2005	Colburn et al.	
7,213,716	B2	5/2007	William et al.	
7,252,203	B2	8/2007	Frankenberger et al.	
7,441,670	B2	10/2008	Willim	
7,546,928	B2	6/2009	Pech et al.	
7,967,158	B2	6/2011	Pech et al.	
8,162,160	B2	4/2012	Zollondz et al.	
1,139,915	A1	5/2015	Smulders	
2002/0070186	A1	6/2002	Frommelt et al.	
2003/0146181	A1	8/2003	Taylor et al.	
2005/0098520	A1	5/2005	Frankenberger et al.	
2005/0194339	A1	9/2005	Willim	
2006/0283826	A1	12/2006	Yeral	
2008/0099421	A1 *	5/2008	Pech et al. 212/196	
2008/0116161	A1	5/2008	Kurotsu et al.	
2008/0203045	A1	8/2008	Pech et al.	
2011/0031202	A1	2/2011	Pech et al.	
2013/0161278	A1	6/2013	Sun et al.	

FOREIGN PATENT DOCUMENTS

CN	2 250 345	Y	3/1997
CN	2 355 001	Y	12/1999
CN	1287964	A	3/2001
CN	2 642 757	Y	9/2004
CN	1 562 724	A	1/2005
CN	1562724	A	1/2005
CN	1740080	A	3/2006
CN	1765729	A	5/2006
CN	2 059 156	U	5/2007
CN	101 445 209	A	6/2009
CN	201 284 198	Y	8/2009
CN	102285600	A	12/2011
DE	1007039	C2	10/1957
DE	1246969		8/1967
DE	1264010		3/1968
DE	12 81 128	B	10/1968
DE	73132		5/1970
DE	1781119		10/1970
DE	3 438 937		4/1986
DE	268458	A1	5/1989
DE	38 38 975		5/1990
DE	94 04 670	U1	2/1995
DE	19642066	A1	4/1998
DE	297 23 587		12/1998
DE	19908485	A1	8/2000
DE	19929549	A1	1/2001
DE	19931303	A1	2/2001
EP	0 048 076		3/1982
EP	0110786	A1	6/1984
EP	0 132 572		2/1985
EP	0354167	A1	2/1990
EP	0368463	A1	5/1990
EP	0 379 448		7/1990
EP	0 856 486	A2	8/1998
EP	0 945 393		9/1999
EP	1135322	B1	9/2001
EP	1 205 422		5/2002
EP	1619159	A2	1/2006
EP	1 916 220	A1	4/2008
EP	1934129	B1	6/2008
EP	1 990 306	A2	11/2008
EP	2497740	A1	9/2012
FR	1408409		7/1965
FR	1469592	A	2/1967
FR	1548415	A	12/1968
FR	2172931		10/1973
FR	2 497 903	A	7/1982

(56)

References Cited

FOREIGN PATENT DOCUMENTS

FR	2536733		6/1984
GB	113 730 A		3/1918
GB	190 594 A		12/1922
GB	604 852 A		7/1948
GB	1020635		2/1966
GB	1179513		1/1970
GB	1207492		10/1970
GB	1218826		1/1971
GB	1291541		10/1972
GB	1311767		3/1973
GB	1 458 170 A		12/1976
GB	2029795 A		3/1980
GB	2050295 A		1/1981
GB	2 096 097 A		10/1982
GB	2 130 682		6/1984
GB	2151580 A		7/1985
GB	2159122 A		11/1985
GB	2 353 515 A		2/2001
GB	2 371 284		7/2002
GB	2422139 A		7/2006
JP	55145993		11/1980
JP	56-145094 A		11/1981
JP	1982-096190		6/1982
JP	59-43796 A		3/1984
JP	62-41192		2/1987
JP	62 203891 A		9/1987
JP	U 1988-026690		2/1988
JP	1988-032893		3/1988
JP	02-70696 A		3/1990
JP	A 1990-182696		7/1990
JP	A 1991-158392		7/1991
JP	H 9-328293 A		12/1997
JP	10-87278 A		4/1998
JP	11-29291		2/1999
JP	11-49484 A		2/1999
JP	1999-157780		6/1999
JP	2002-020081		1/2002
JP	2002-531357		9/2002
JP	2003-184086		7/2003
JP	2005-138962		6/2005
JP	2008127150 A		6/2008
JP	A 2008-143626		6/2008
JP	2009-7164 A		1/2009
RU	2075430 C1		3/1997
RU	2268234		1/2006
SU	88589		1/1950
SU	551238		5/1977
SU	652096		3/1979
SU	1087455		4/1984
SU	1346567 A		10/1987
SU	1463705 A2		7/1989
SU	1477663 A1		7/1989
SU	1521703 A1		11/1989
WO	WO9429211		12/1994
WO	WO 00/34173 A1		6/2000
WO	WO 2003/040016 A1		5/2003
WO	WO 2005/026036		3/2005
WO	WO 2007/056970 A1		5/2007

OTHER PUBLICATIONS

Sections of brochure entitled “LR 11200 Crawler Crane—Technical Data,” Liebherr, 4 pages (cover page, pp. 14, 16a and 16b), undated, but prior to Oct. 27, 2006.

Sections of brochure entitled “Model 21000 Product Guide,” Manitowoc, 4 pages, undated, but prior to Oct. 27, 2006.

Brochure “MR Range: Potain”, Manitowoc Crane Group, 4 pages (Mar. 2004) with accompanying photographs (6 pages).

Brochure “Multi Tasker 100/250/810/1000/1200/1600, Railway Crane,” Kirow, a member of Kranunion, 16 pages (undated but prior to Aug. 6, 2009).

CART 587T Pipelayer Specifications, 20 pages (undated).

Data Sheet “Potain MR 605 B H32”, Manitowoc Crane Group, 8 pages (2011).

GROVE, T80/T86J Telescopic Boom Work Platforms, 4 pages (2000).

Liebherr, LR1600/2 Dimensions, 3 pages (undated, but prior to Aug. 6, 2009).

Liebherr, LR1600/2 Technical Data, 7 pages (undated).

Liebherr, RL44 Litronic Pipelayers, brochure, 8 pages (undated).

Manitowoc, Model 16000 Brochure, pp. 1-7, 36-42 showing MAX-ER®, (no date, but 16000 MAX-ER has been on sale since before Aug. 6, 2009).

Manitowoc, Model 18000 Brochure, pp. 1-8, 47-51 showing MAX-ER®, (undated, but 18000 MAX-ER has been on sale since before Aug. 6, 2009).

Manitowoc, M-250 X-Spander /Max-Spander attachment, Operating Controls and Operation folio, 4 pages (Aug. 2, 1994).

Manitowoc, M-250 Max-Spander™ Attachment, Installation and Removal Guide folio, 16 pages (Jun. 3, 1994).

Product Guide “MR Range: Potain”, Manitowoc Crane Group, 4 pages (2007).

TEREX®, DEMAG CC8800-1 Crawler Crane, “Superlift Configurations,” 1 pages (undated, but prior to Aug. 6, 2009).

Journal Article: Mingqin, Z., Xiaoli, S., Zhenbo, Q., Chuanzeng, S. & Mingxiao, D. (2003). “Achievement of the Balance Weight Self Adaptation Adjustments of Cranes Through the Application of a Connecting Rod Mechanism,” *Machine Design and Research*, 19 (4) 379-426.

ANSI/ASME B30.5d-1988, pp. 10 & 16.

Manitowoc Max-Spander Basic Specifications, 4 pages (undated). N1—Chapter in “Special Purpose Vehicle” (2000), pp. 32-36.

N2—One page of an answer book showing connection between rods and hydraulic cylinders.

Respondents’ Disclosure of Invalidity Contentions, ITC Investigation No. 337-TA-887, dated Sep. 20, 2013, 188 pages.

TEREX Demag CC8800-1 Crawler Crane Superlift Configurations, pp. 7-9 (undated).

American A 100-HC General Specifications, 20 pages (undated, but prior to Aug. 6, 2009).

Manitowoc M-50W brochure, 6 pages (1989).

Terex American HC 210 brochure, 2 pages (2002).

Terex American HC 125 brochure, 2 pages (2001).

Document entitled “X-Spander Attachment,” 1 page (undated, but prior to Aug. 6, 2009).

Document entitled “X-Spander Blueprint,” 1 page (1989).

English translation of Decision of Invalidation (No. 22307), Case No. 4W102283, for Chinese Patent No. 200810092407.6, dated Mar. 14, 2014 (43 pages).

English translation of Examination Decision on the Request for Invalidation, Case No. 4W102286, for Chinese Patent No. 200710192985.2, dated Mar. 14, 2014 (53 pages).

Liftcrane Capacities and Liftcrane Jib Capacities for M-250 with X-Spander, dated Jan. 21, 1994 and Mar. 23, 1994, 88 pages.

TEREX®, DEMAG CC8800-1 Crawler Crane, “Superlift Configurations,” 1 page (undated, but prior to Aug. 6, 2009).

Communication for EP Application No. 10172110.8, dated Apr. 29, 2015 (4 pages).

COLMAR Railroad Loader T7000FS, Specifications, 1 page (2014)—DVD.

COLMAR Railroad Loader T10000FS, Specifications, 2 pages (2014)—DVD.

European Search Report for EP Application No. 10172110.8, dated Nov. 25, 2010 (6 pages).

European Search Report for EP Application No. 13153415.8, dated Mar. 22, 2013 (9 pages).

European Search Report for EP Application No. 13153486.9, dated Mar. 22, 2013 (5 pages).

European Search Report for EP Application No. 14183968.8, dated Feb. 13, 2015 (10 pages).

First Office Action for Chinese Application No. 201010624732.X, dated Nov. 2, 2012 (13 pages).

First Office Action for Chinese Application No. 201210253579.3, dated Feb. 12, 2014 (16 pages).

Notification of Reason for Rejection for JP Application No. 2008-077842, dated Nov. 24, 2011 (3 pages).

(56)

References Cited

OTHER PUBLICATIONS

Notification of Reason for Rejection for JP Application No. 2010-175871, dated Jul. 1, 2014 (5 pages).
Office Action for RU Application No. 2007-139810, dated Apr. 12, 2012 (13 pages).
Partial European Search Report for EP Application No. 14183968.8, dated Dec. 16, 2014 (7 pages).
Search Report from related Chinese Application No. 201210253579.3, dated Nov. 24, 2014 (2 pages).
Second Office Action for Chinese Application No. 201010511568.1, dated May 14, 2012 (14 pages).
Second Office Action from related Chinese Application No. 201210253579.3, dated Dec. 2, 2014 (10 pages).
Fourth Office Action from related Chinese Application No. 201010624732.X, dated Nov. 3, 2014 (16 pages).
Peng Wensheng, Mechanical Design and Mechanical Principle for Entrance Exams Postgraduate Schools, vol. 2, p. 83 (Huazhong University of Science and Technology Press) (May 31, 2005).
International Search Report and Written Opinion for International Application No. PCT/US2015/013098, dated May 7, 2015 (19 pages).
English language translation of Decision on Rejection, in Chinese Application No. 201010624732.X, dated Jul. 29, 2015, with CN office action (25 pages).

English translation of Decision on Rejection for Chinese Patent Application No. 201210253579.3, dated Aug. 13, 2015, with CN office action (31 pages).
Notification of Reasons for Rejection, and English language translation thereof, in Japanese Application No. 2010-175871, dated Jul. 7, 2015, 16 pages.
Examination Report for related European Application No. 13155808.2, dated Jan. 13, 2016 (7 pages).
European Search Report for EP Application No. 13155808.2, dated Mar. 22, 2013 (6 pages).
European Search Report for EP Application No. 13153480.2, dated Mar. 22, 2013 (7 pages).
Notice of Reexamination for Chinese Application No. 201010624732.X, dated Mar. 30, 2016 (22 pages).
Notice of Reexamination for Chinese Application No. 201210253579.3, dated Mar. 30, 2016 (22 pages).
Decision of Reexamination and English Translation for Chinese Application No. 201010511568.1, dated Dec. 11, 2015, overturning final rejection (39 pages).
Examination Report for related European Application No. 13153480.2, dated Jan. 12, 2016 (7 pages).
Decision of Refusal for JP Application No. 2010-175871, dated Nov. 4, 2015 (2 pages).

* cited by examiner

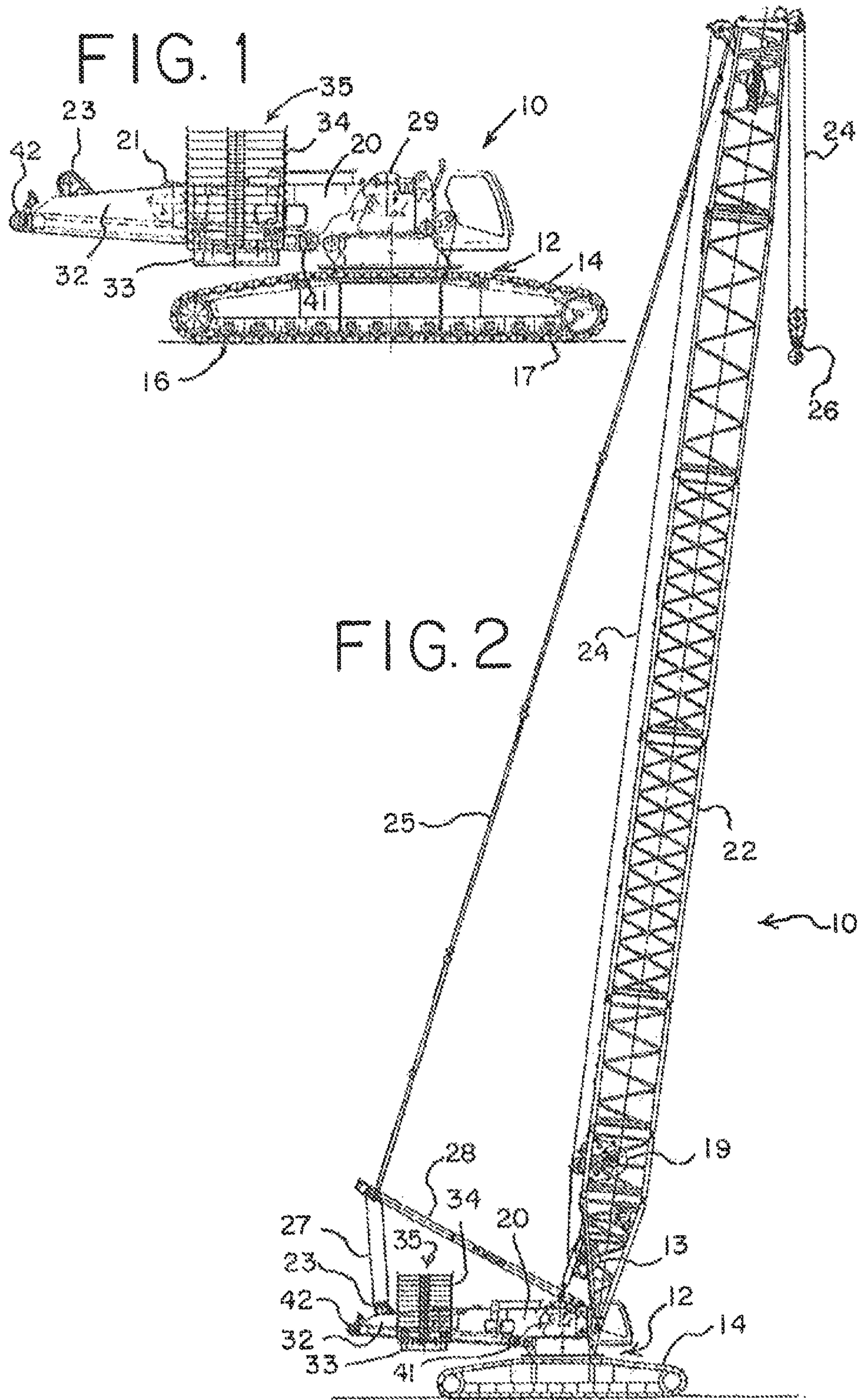
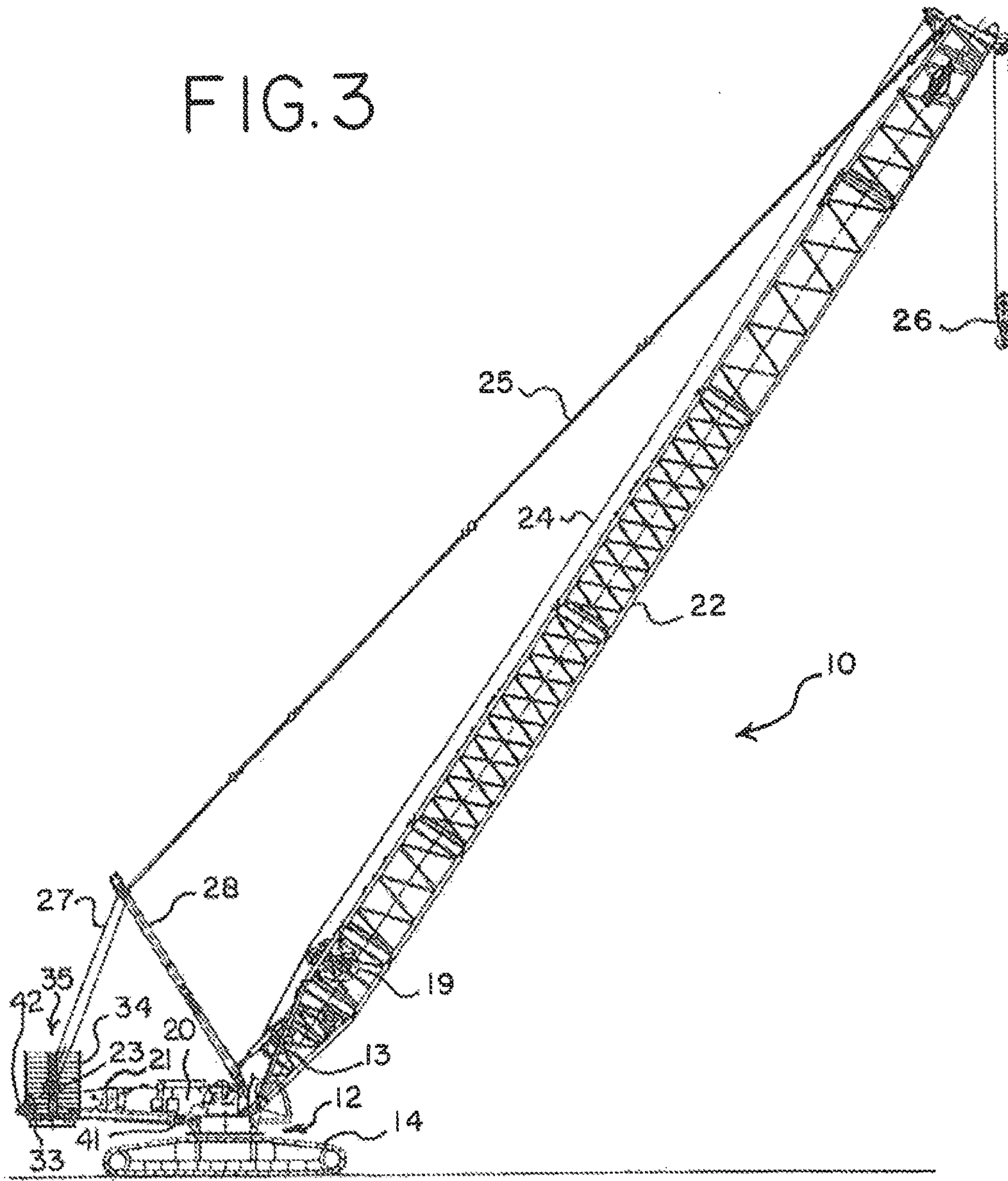

FIG. 3



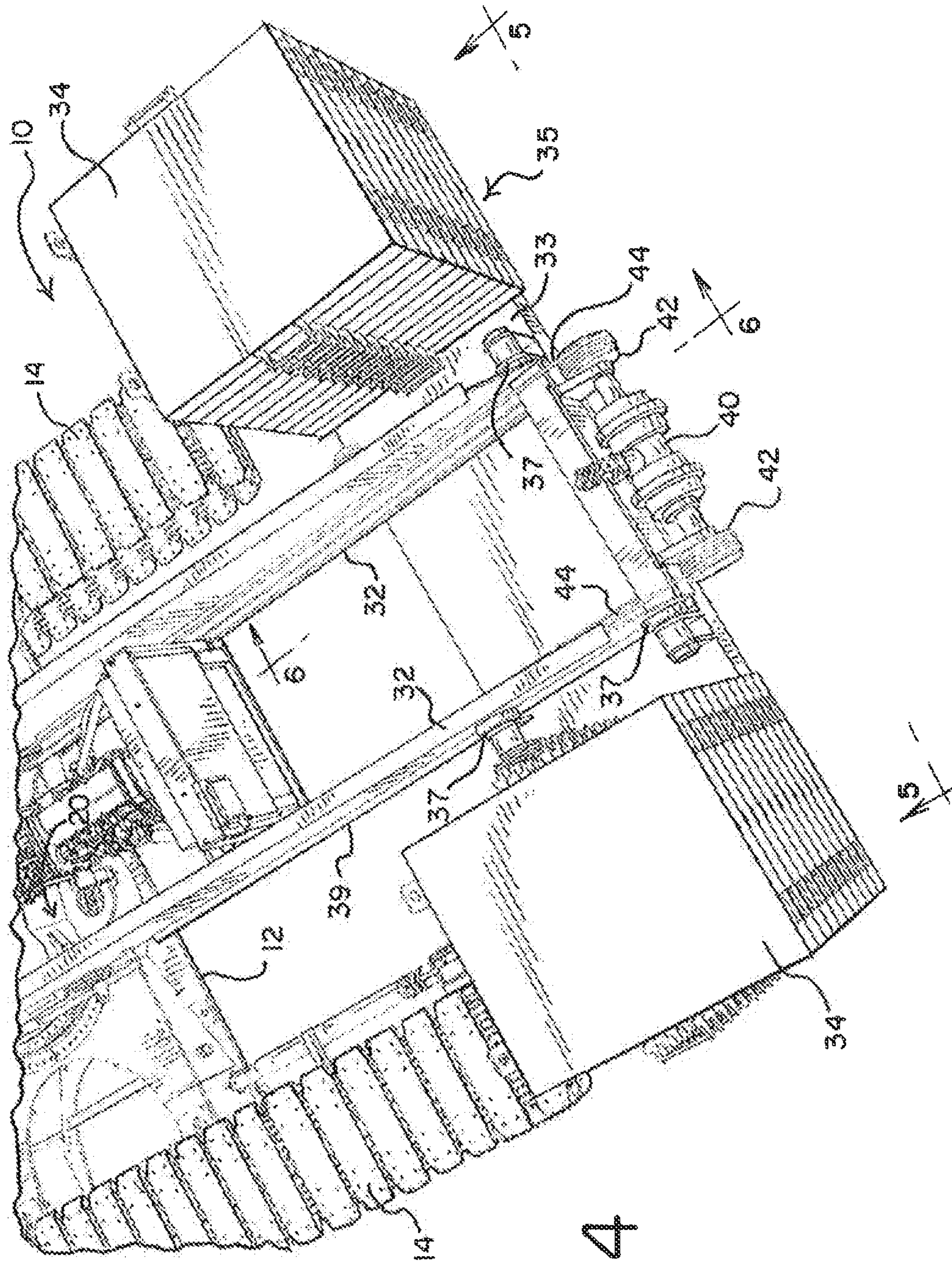
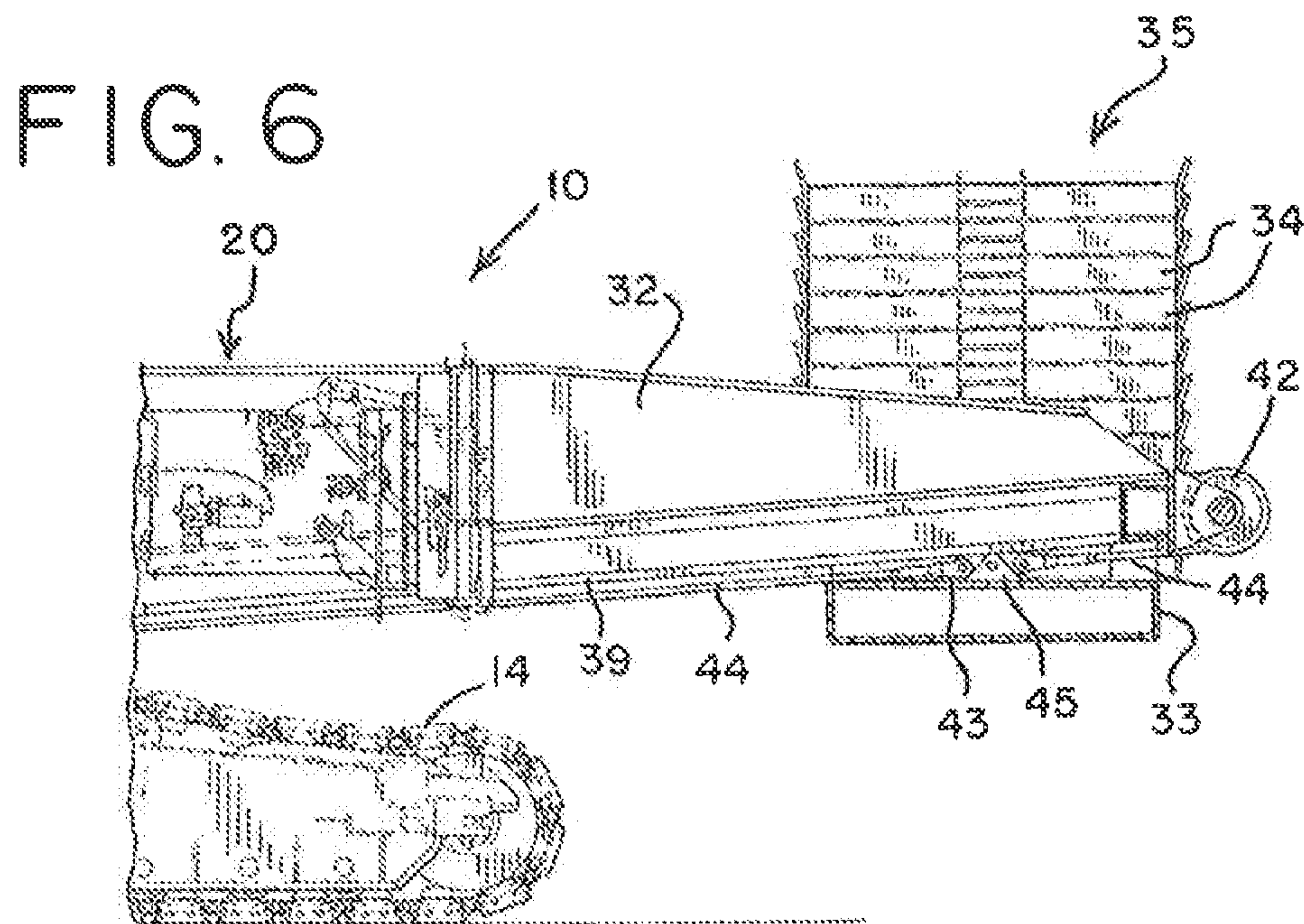
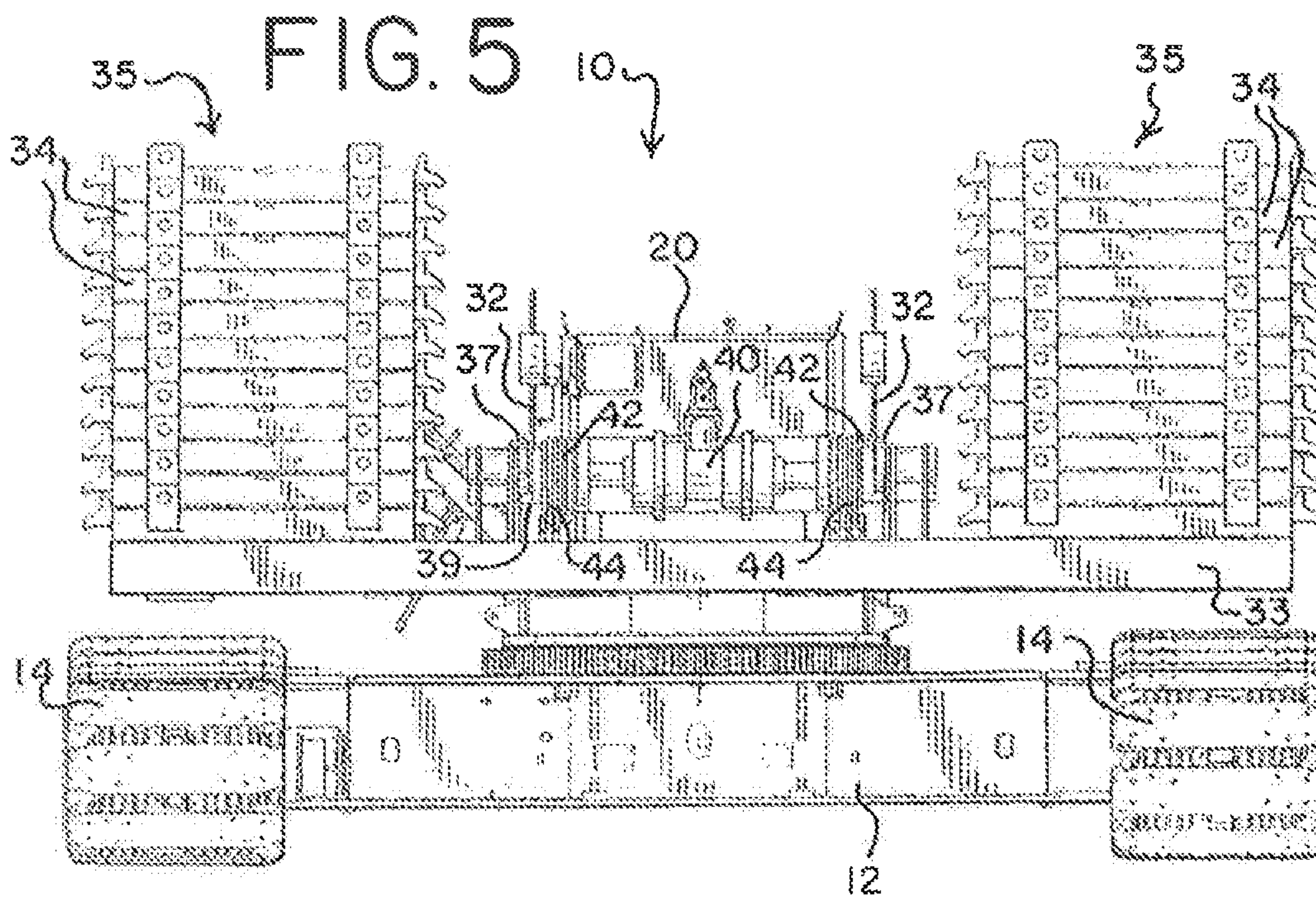

FIG. 4



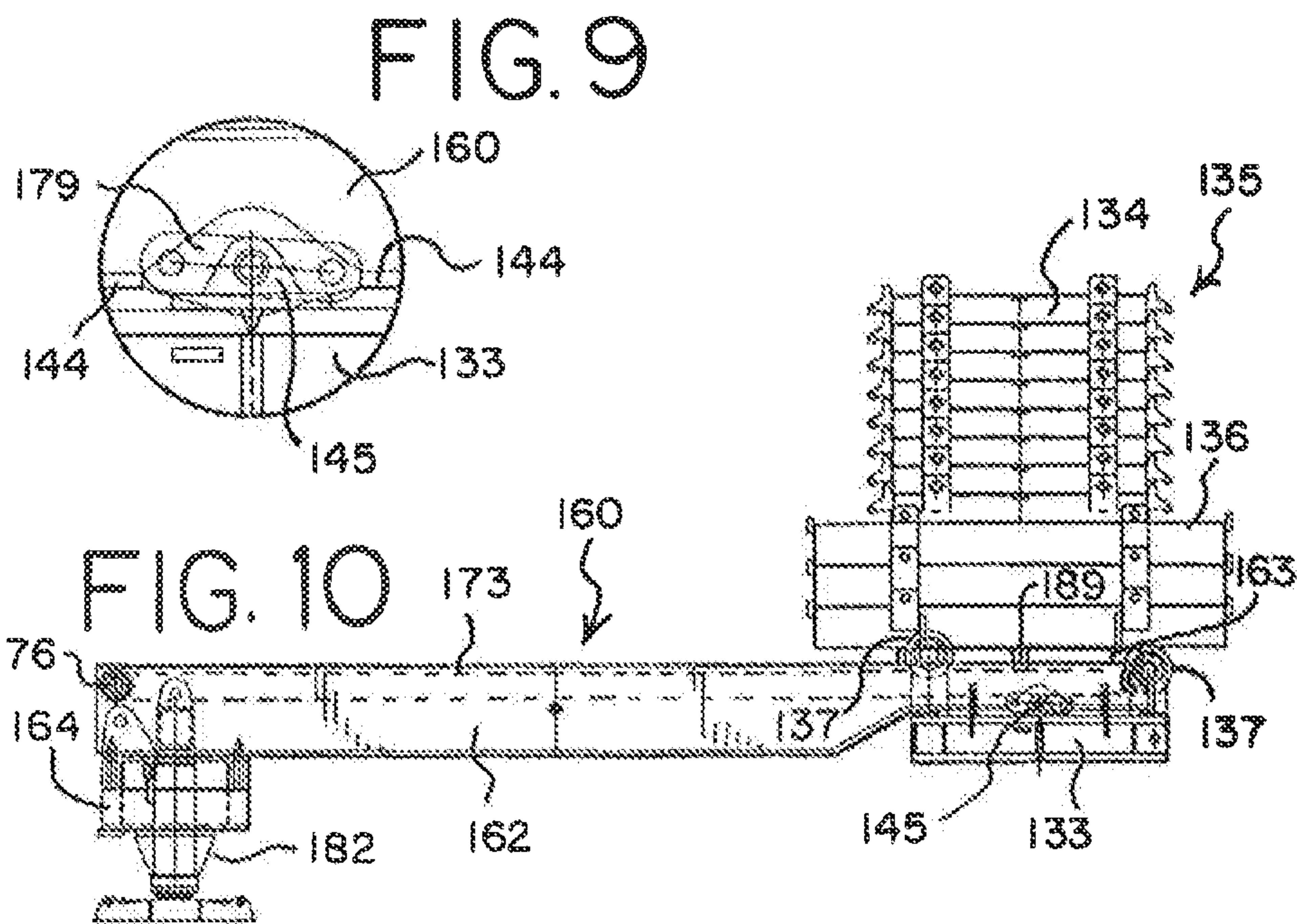
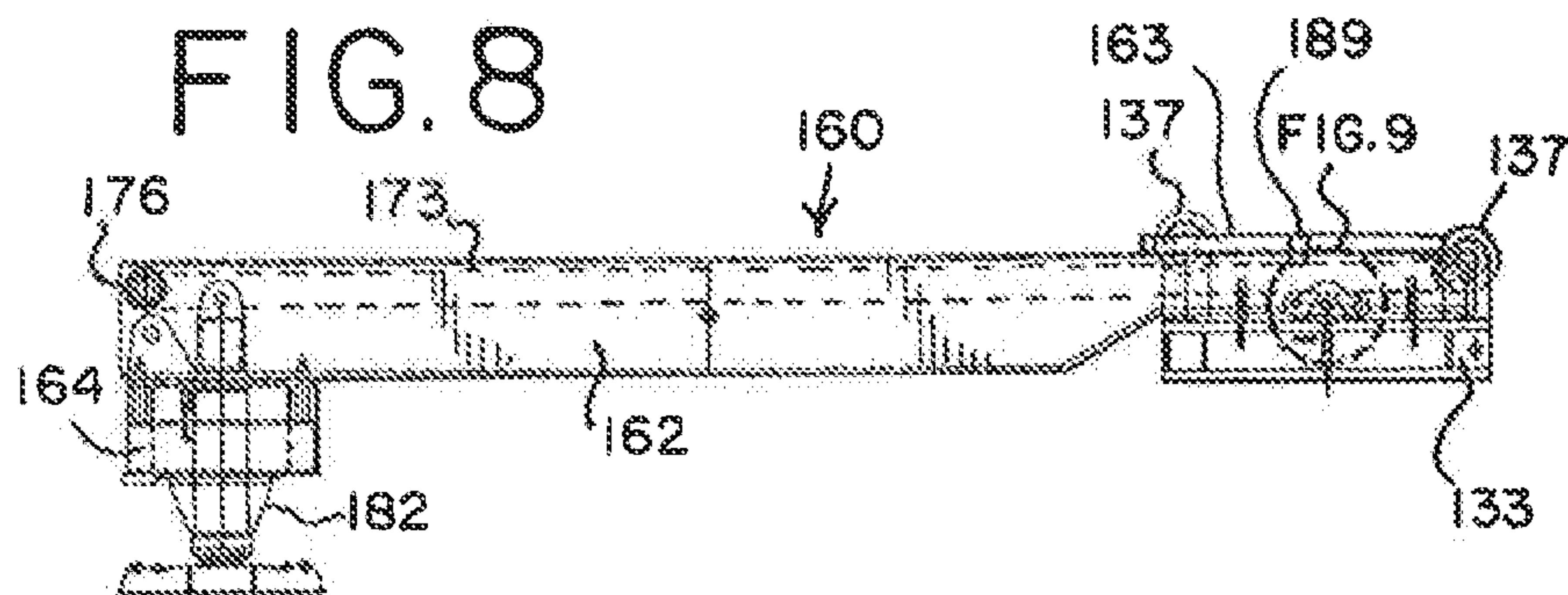
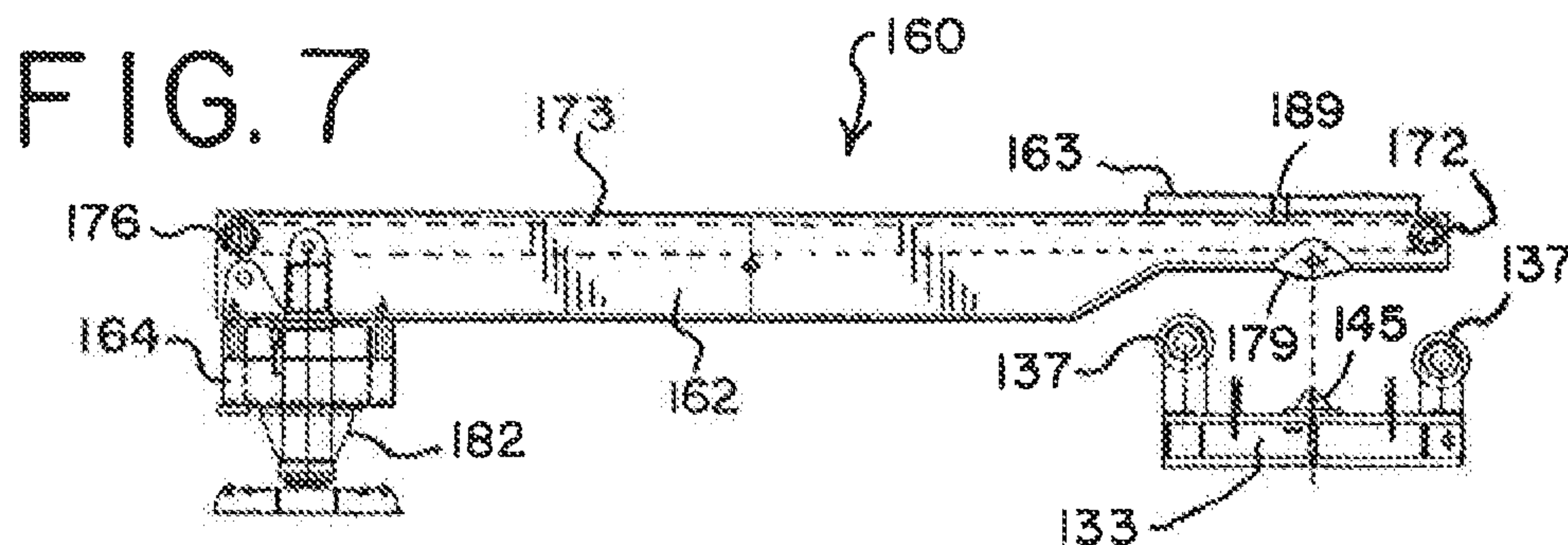

FIG. 11

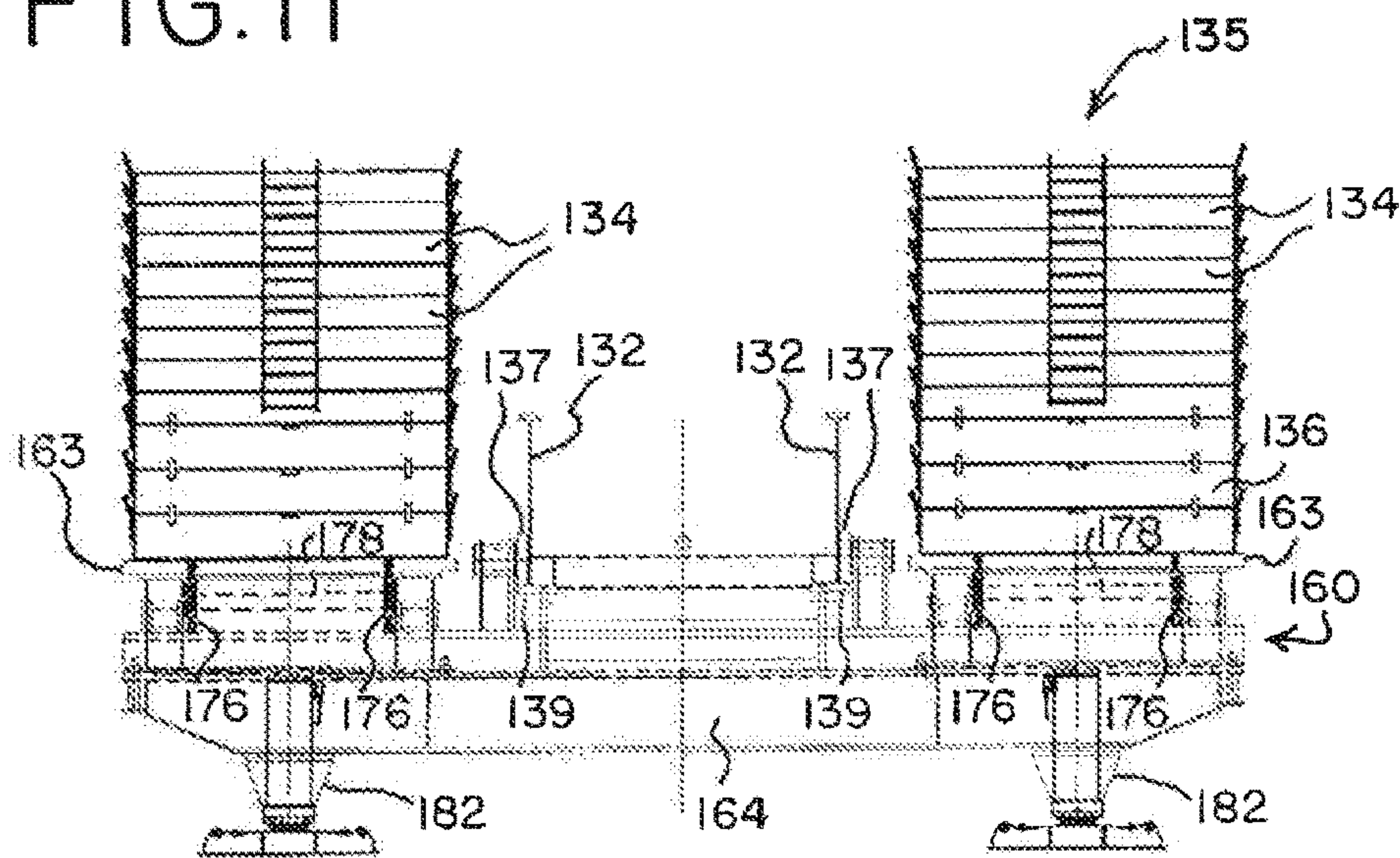
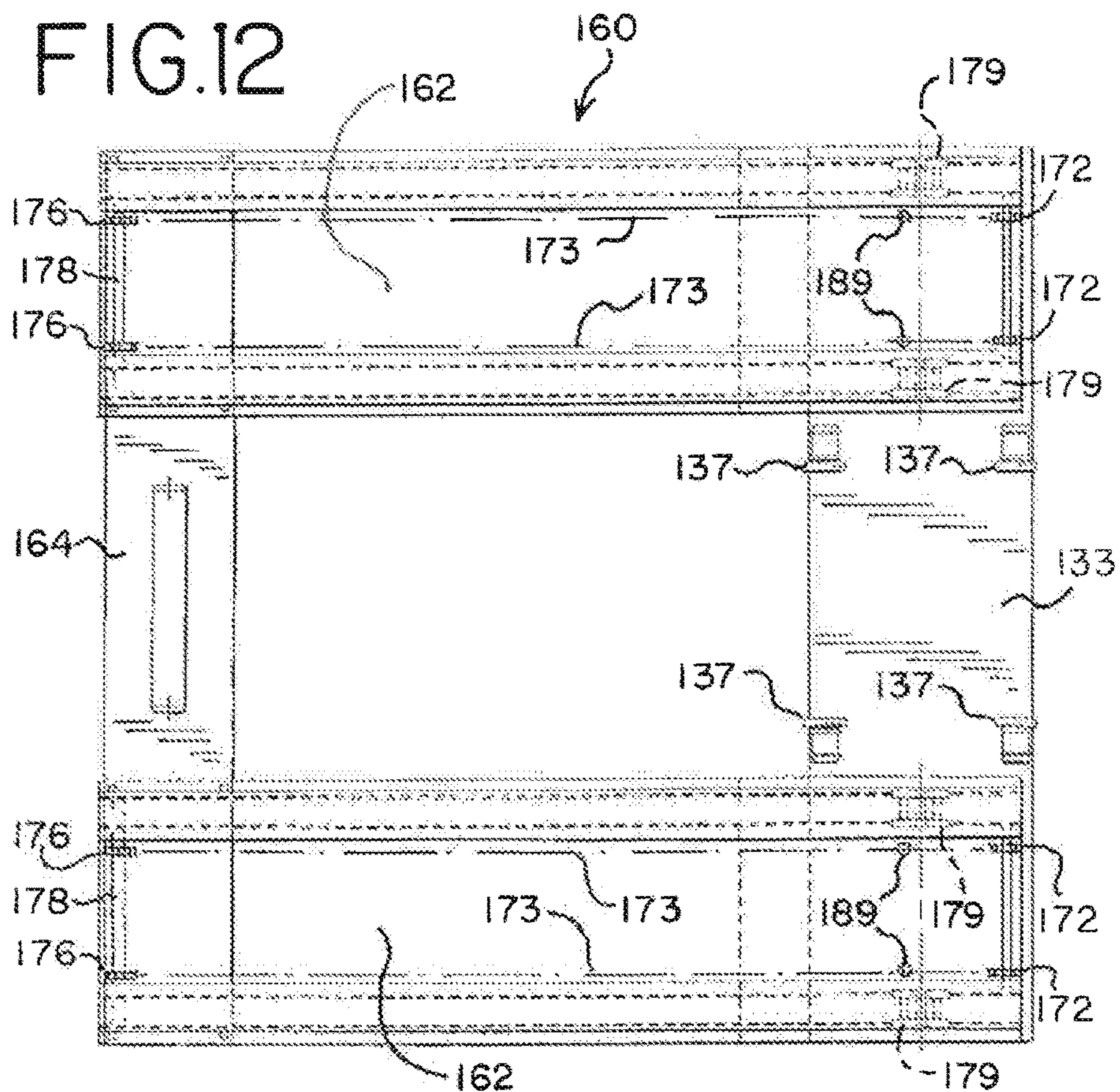
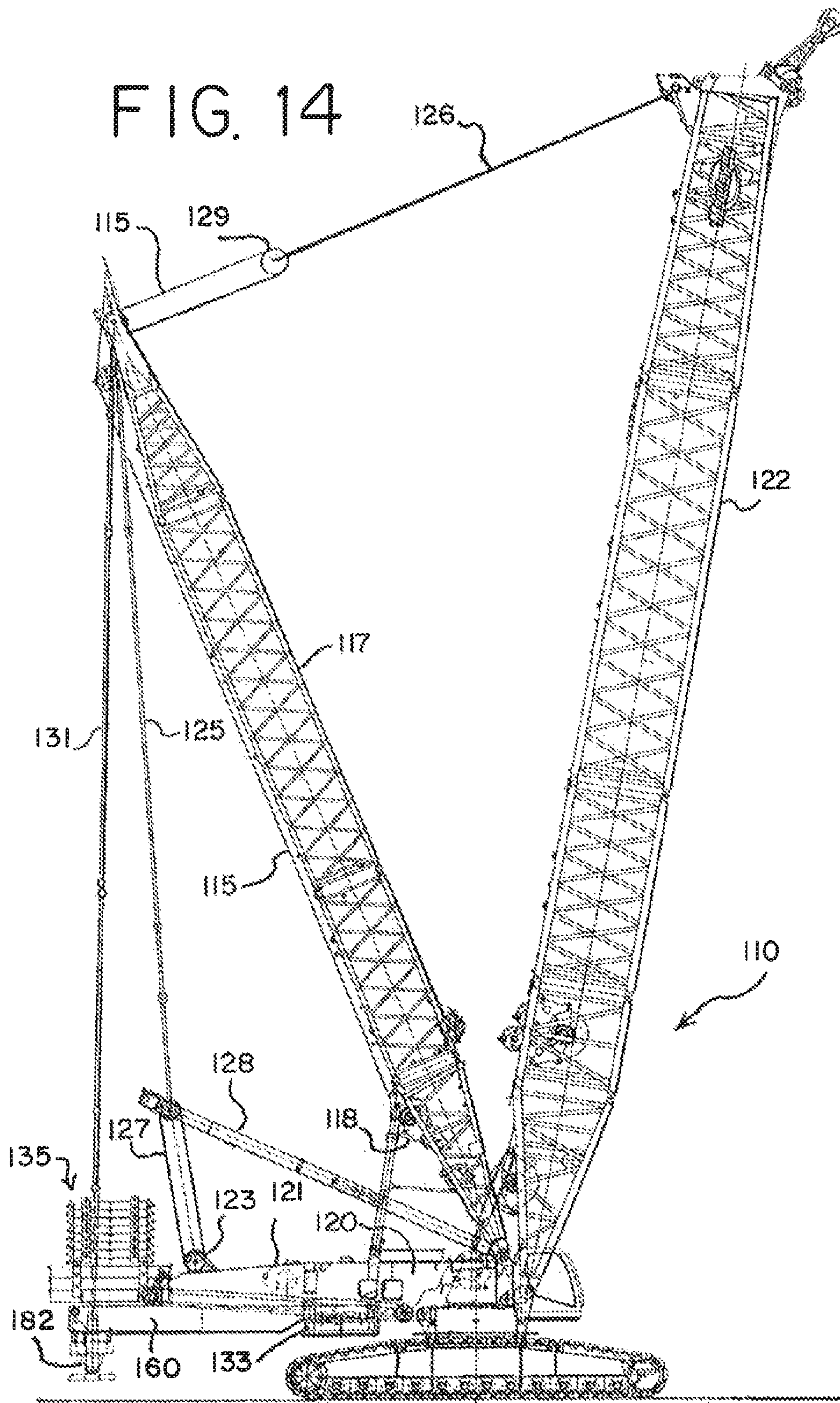
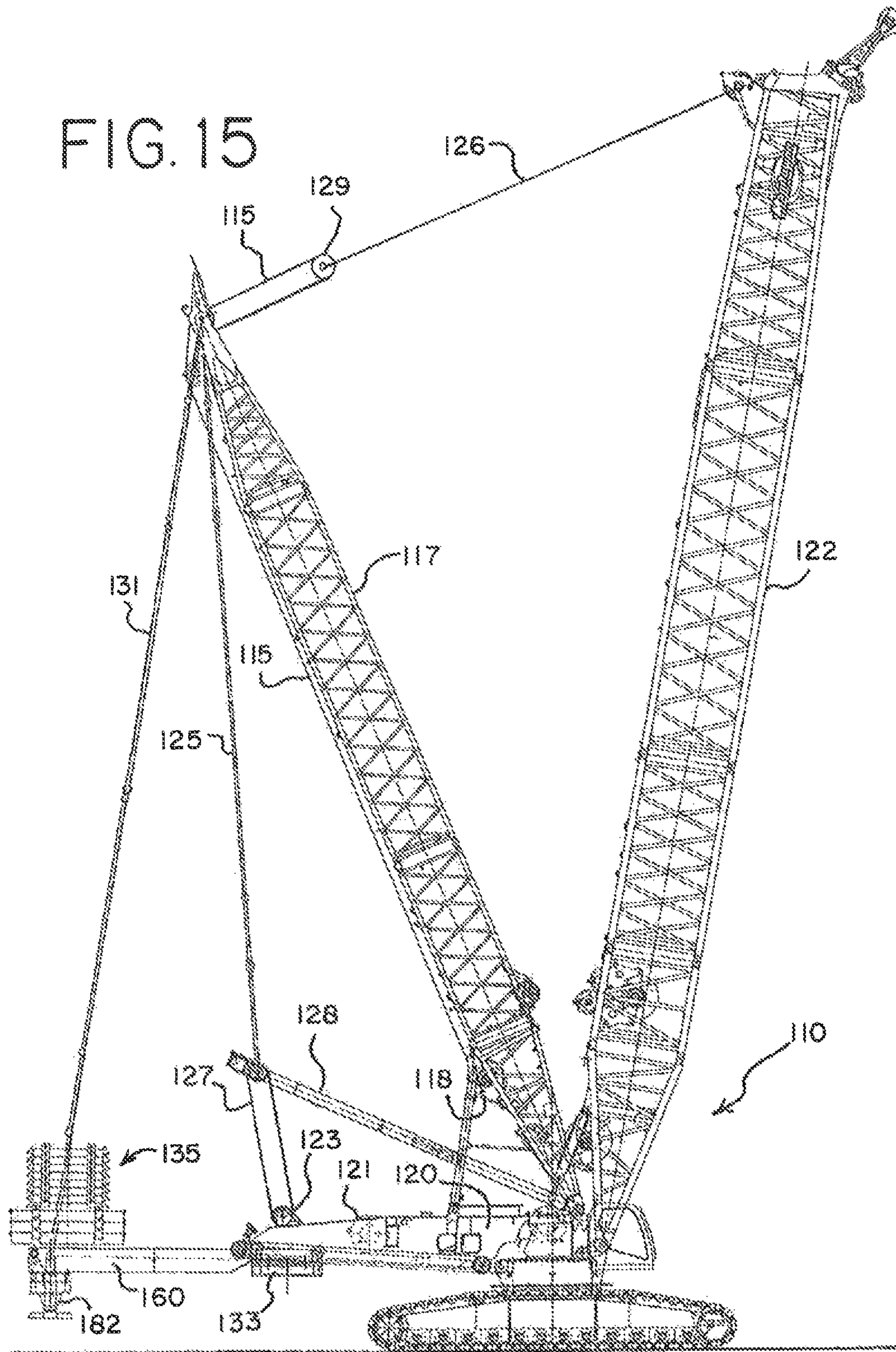

FIG. 12







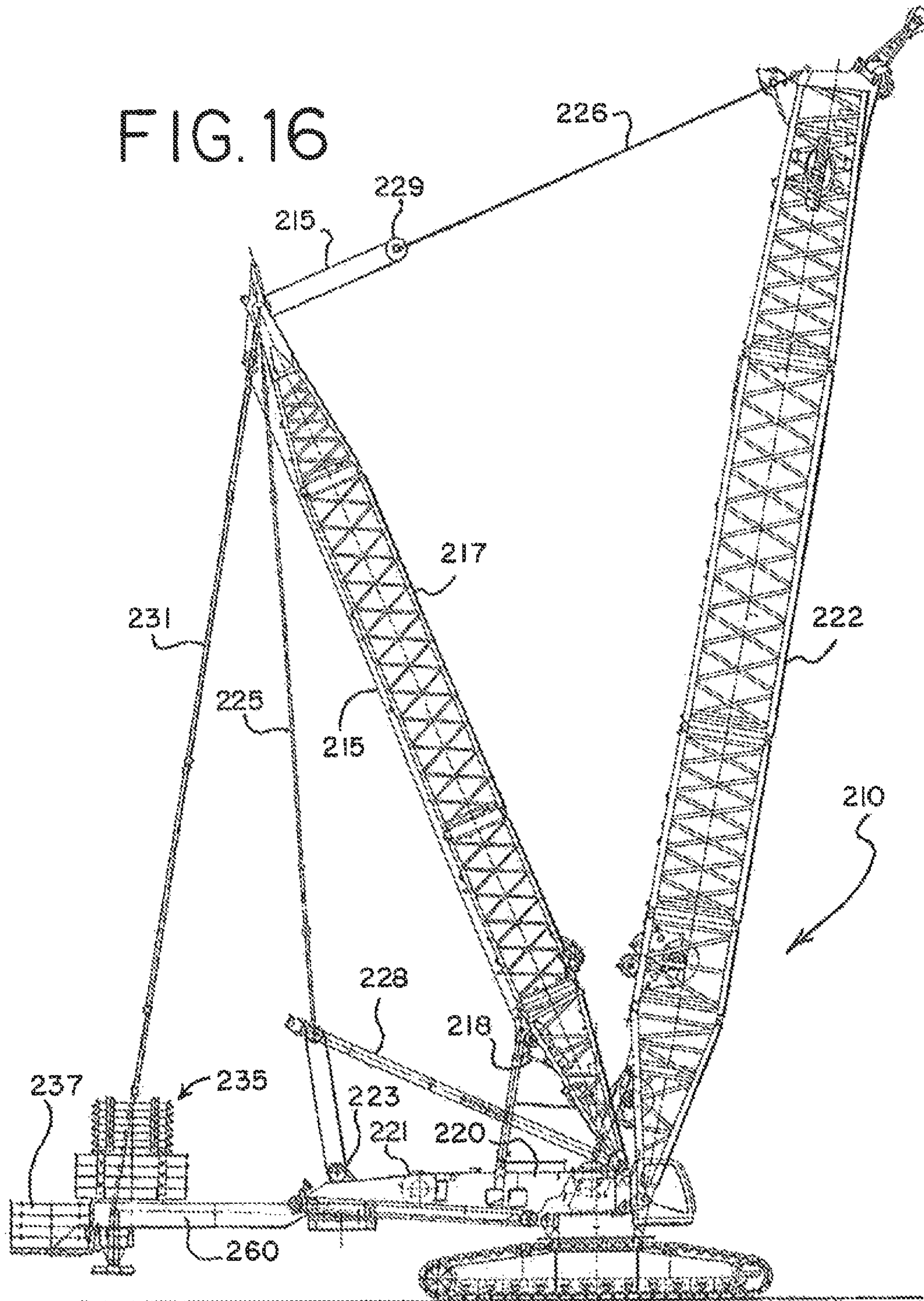
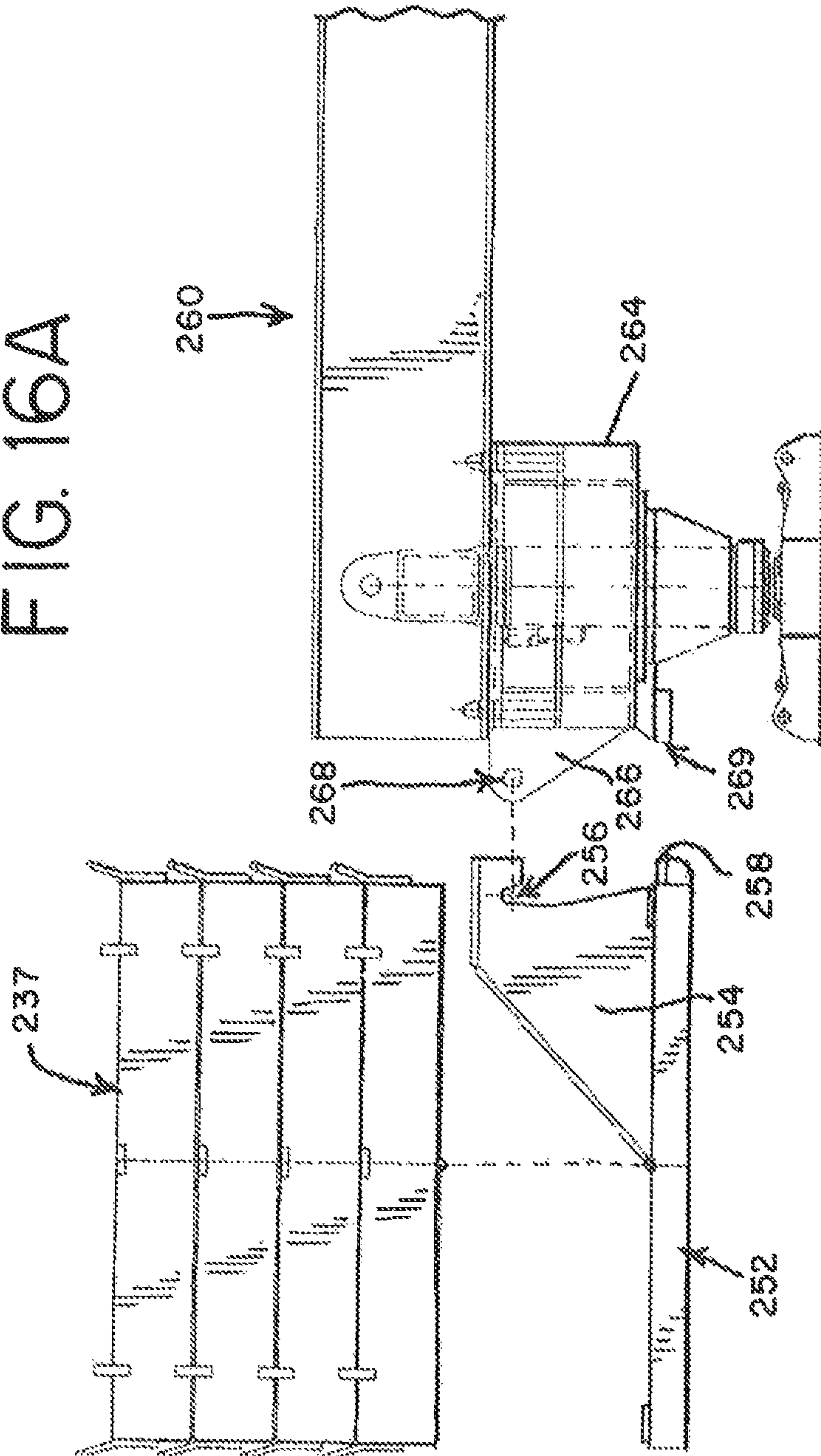
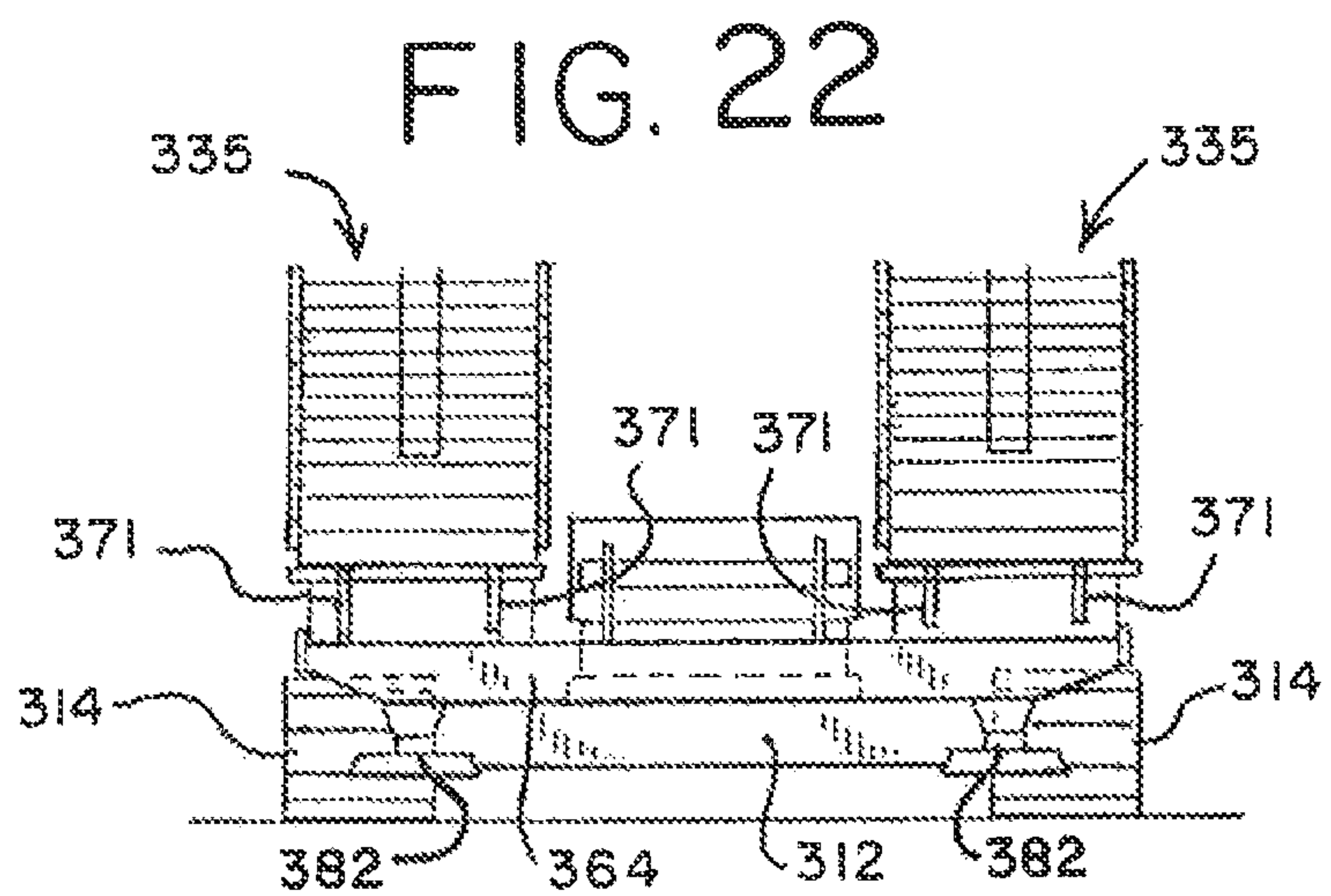
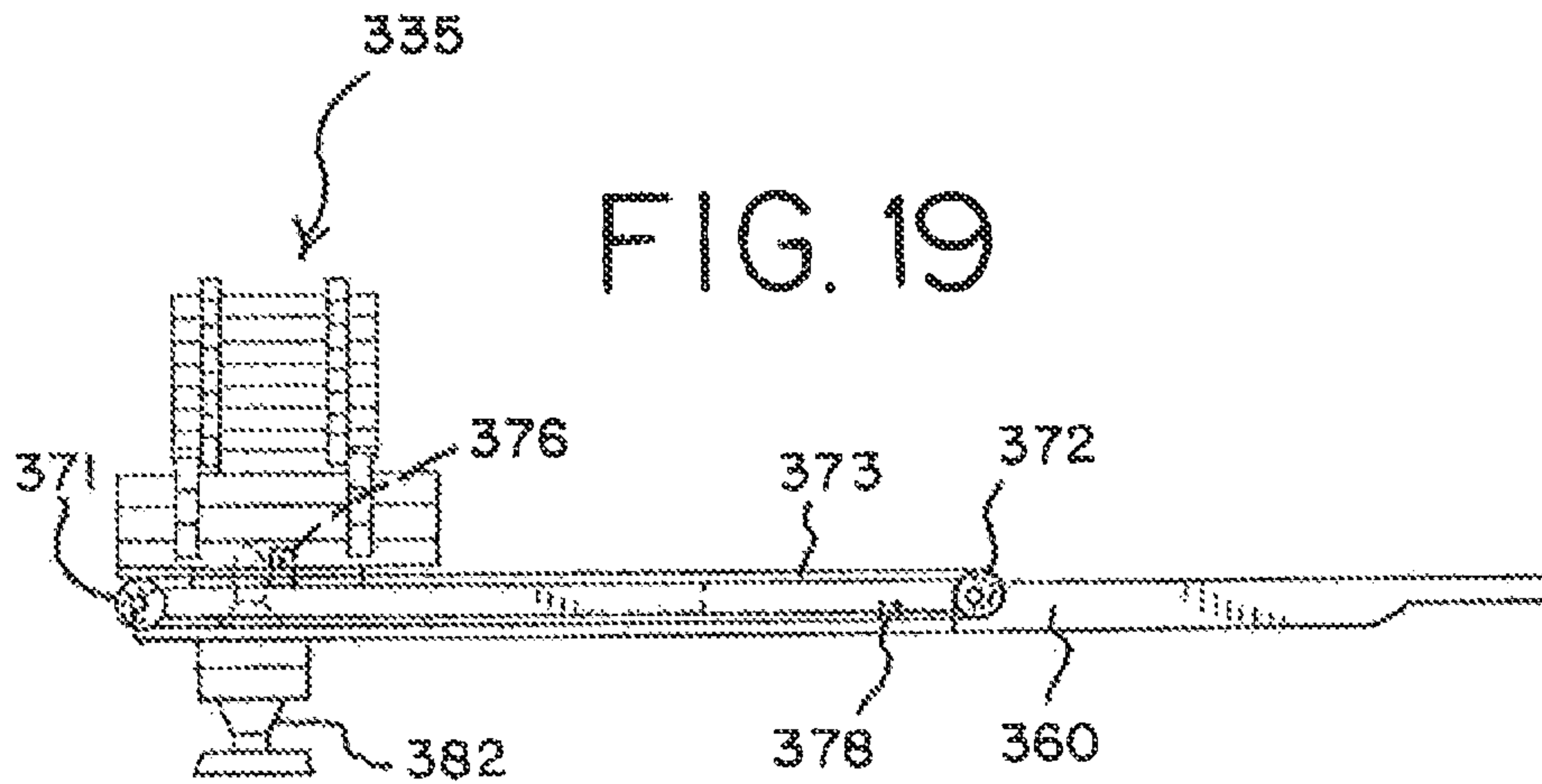

FIG. 16A





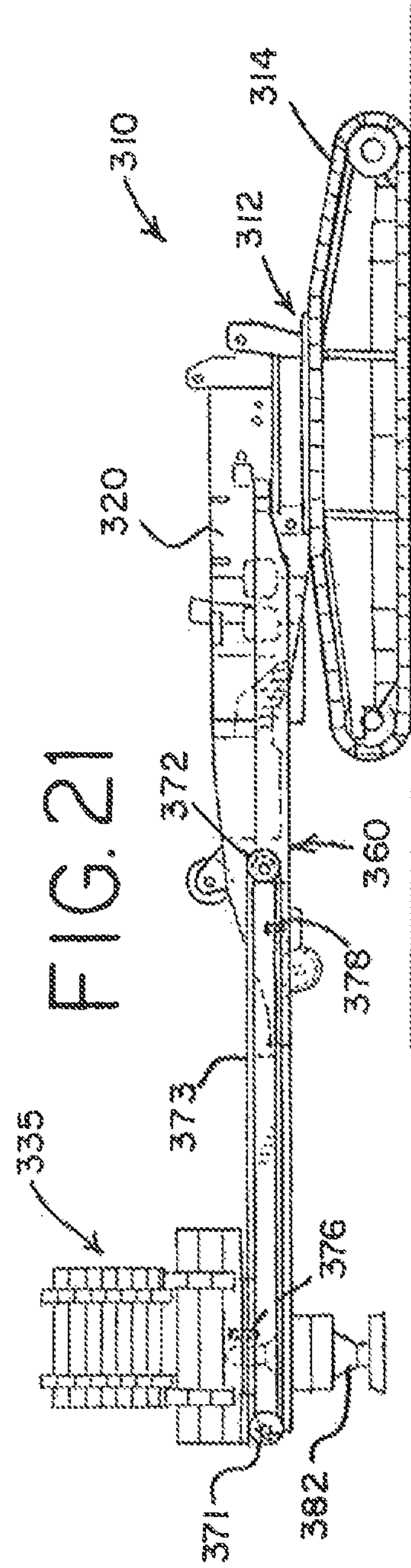
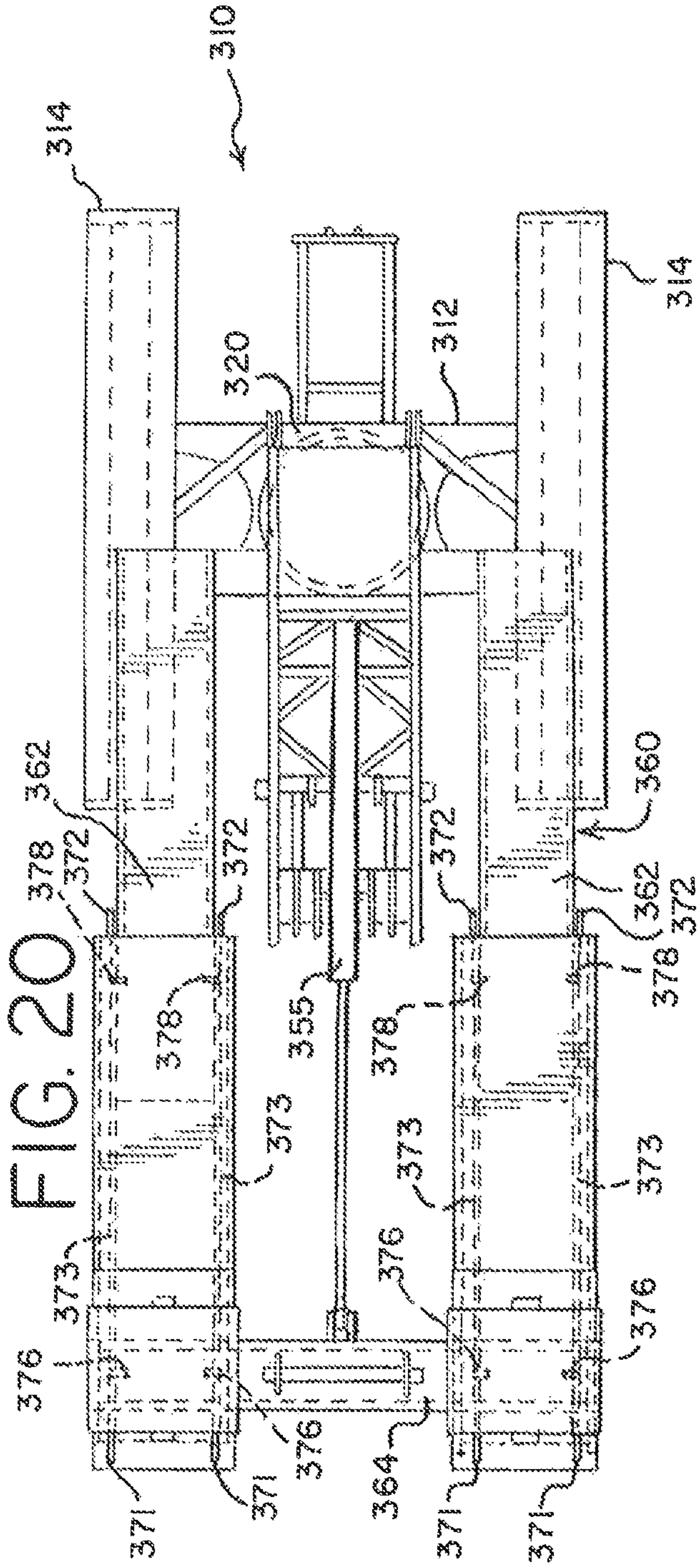

FIG. 23

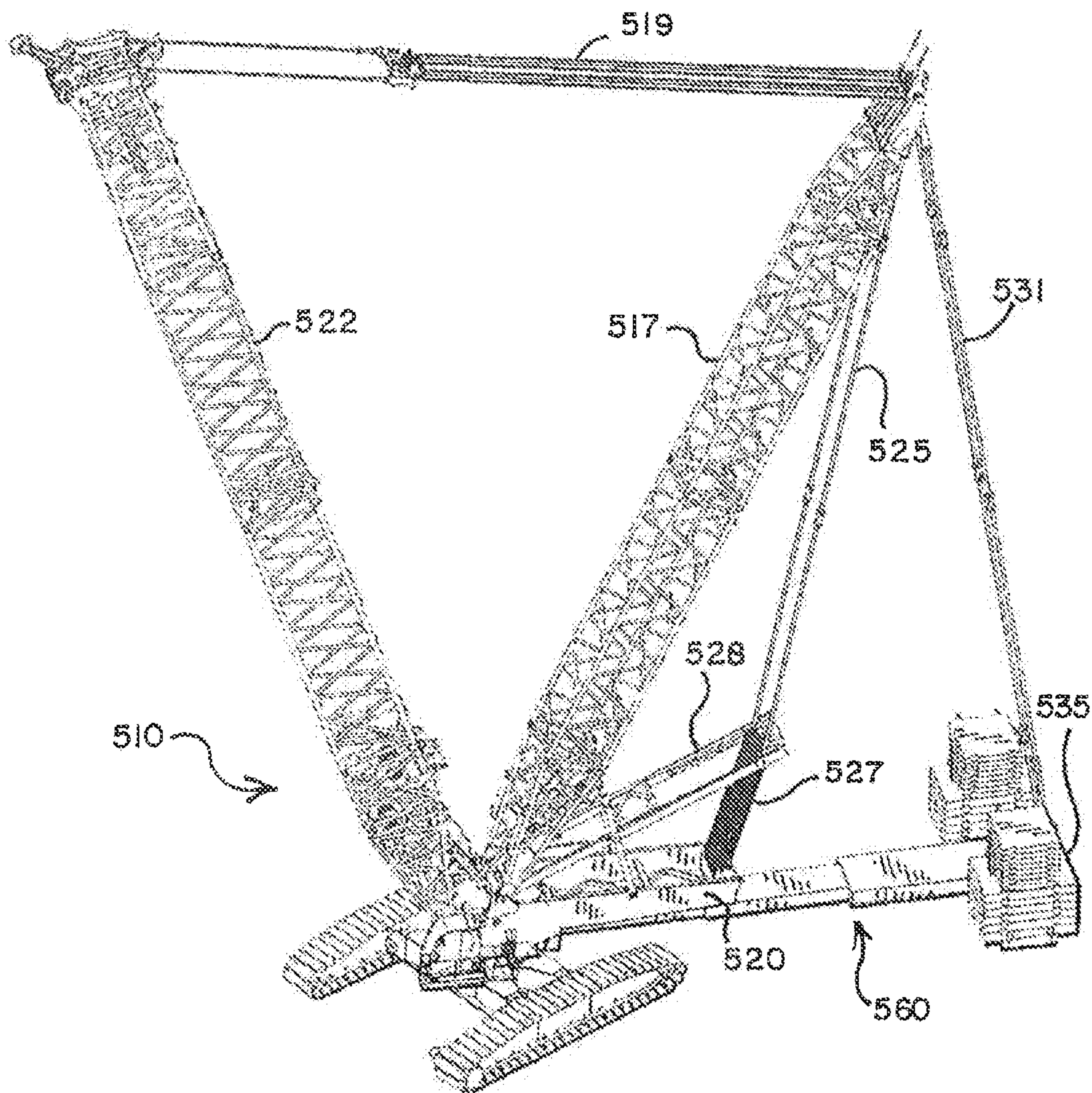
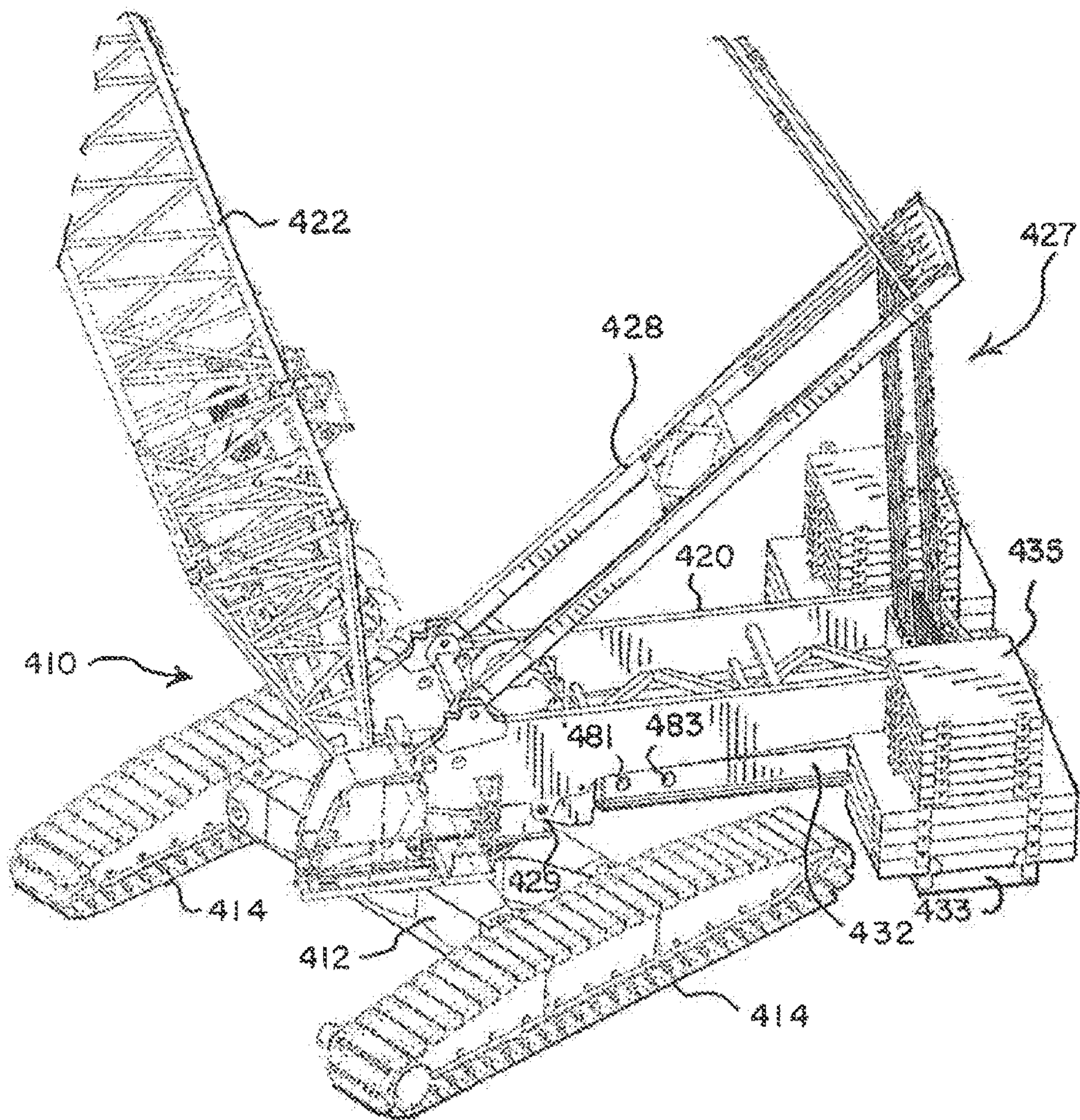

FIG. 25



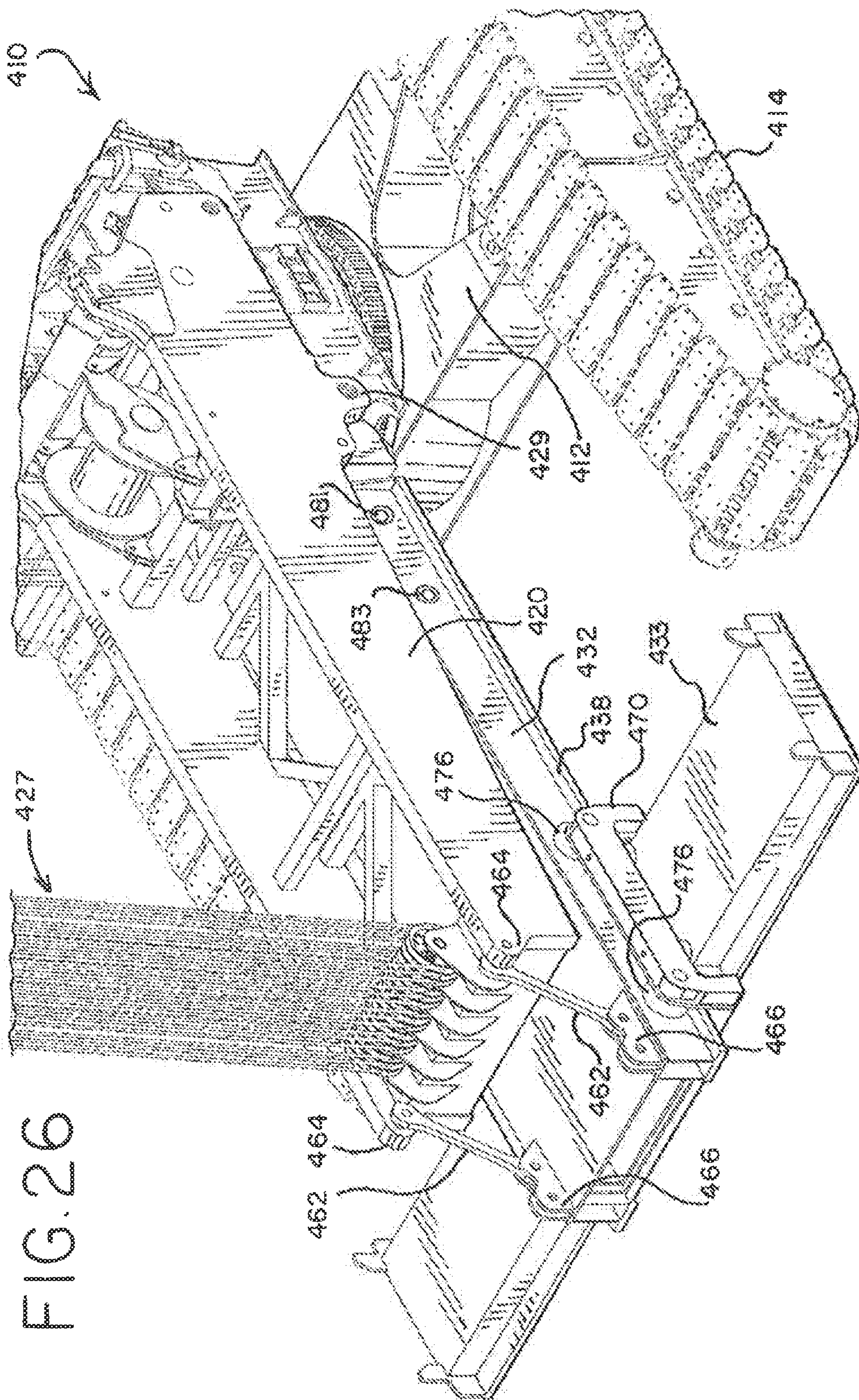
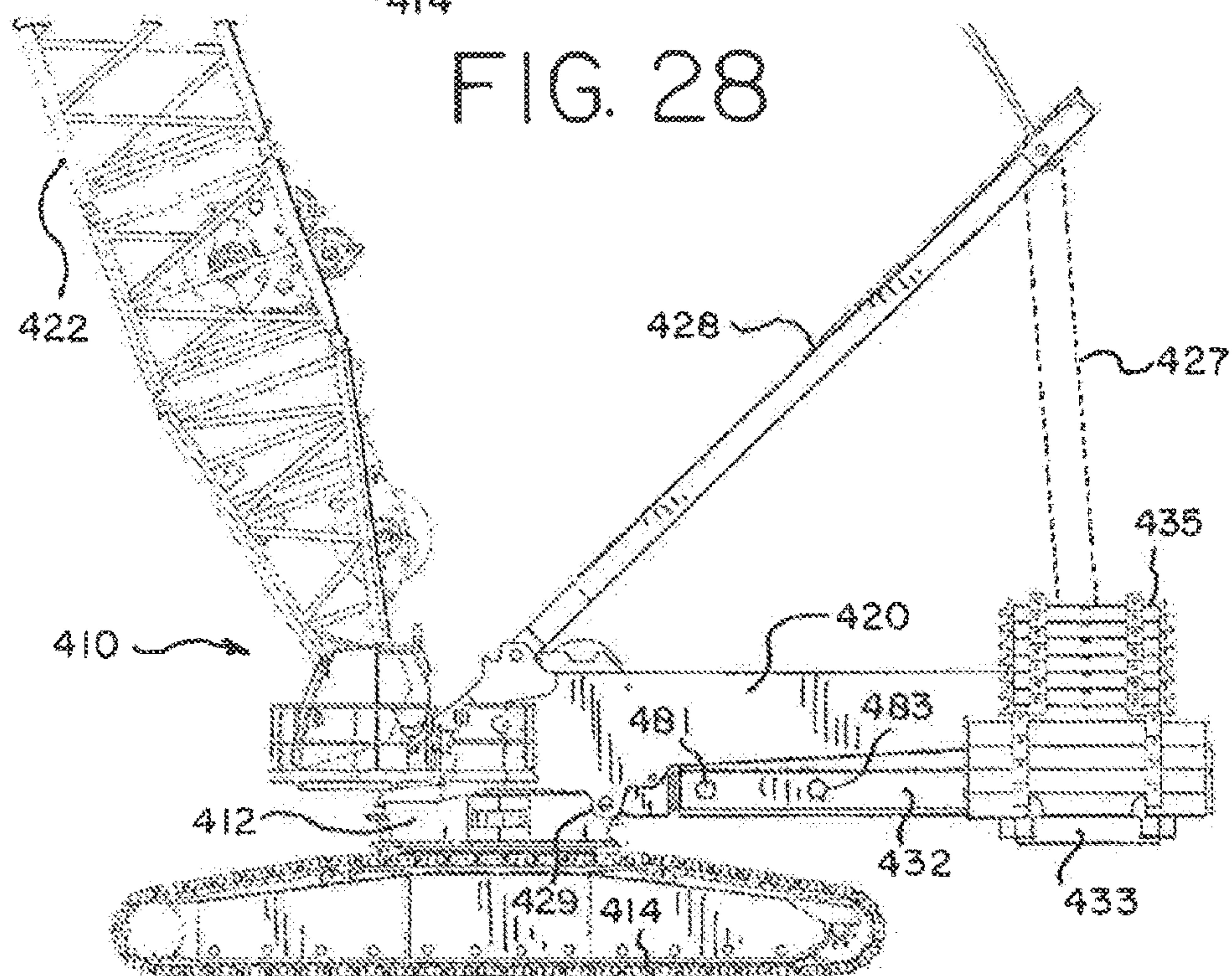
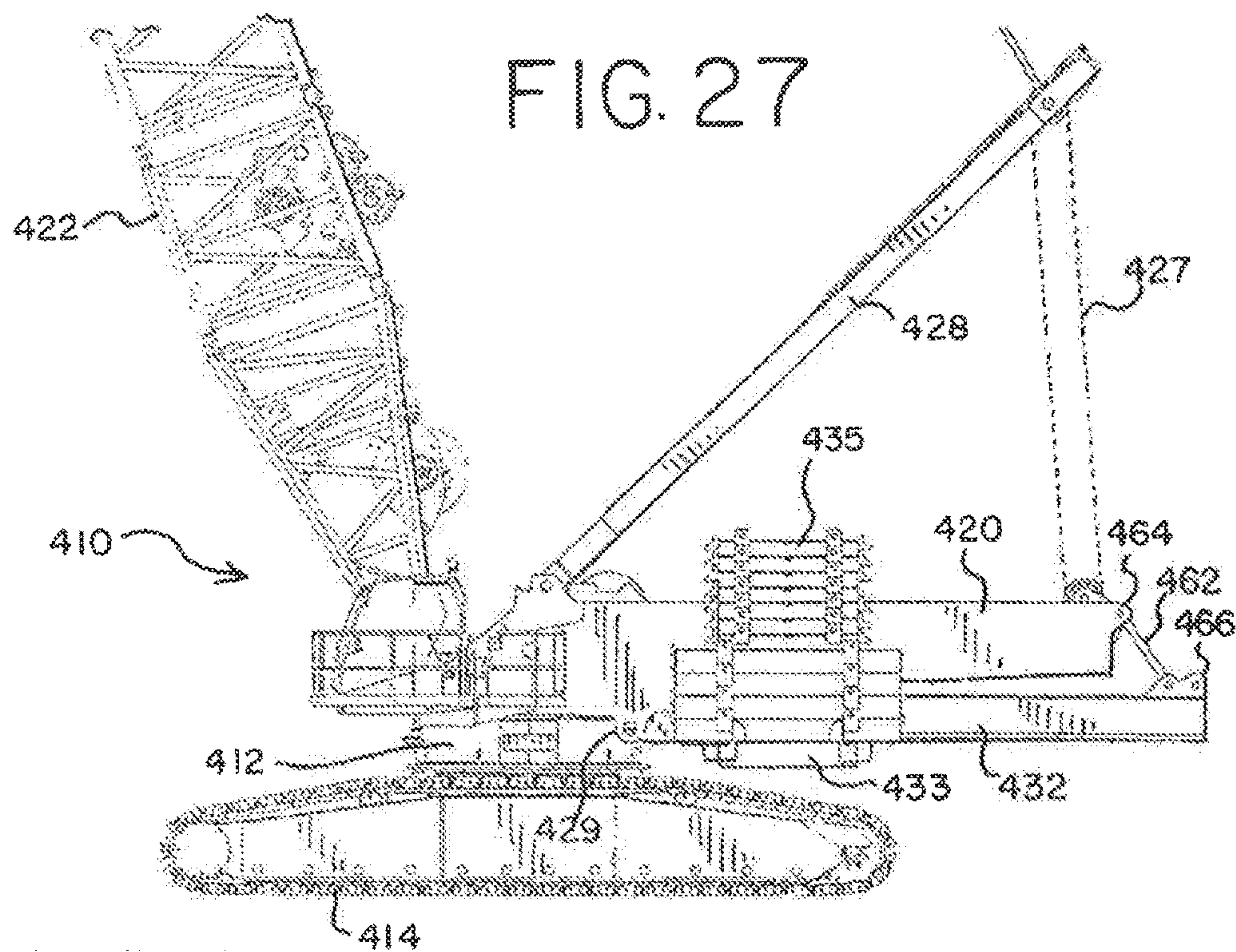

FIG. 26



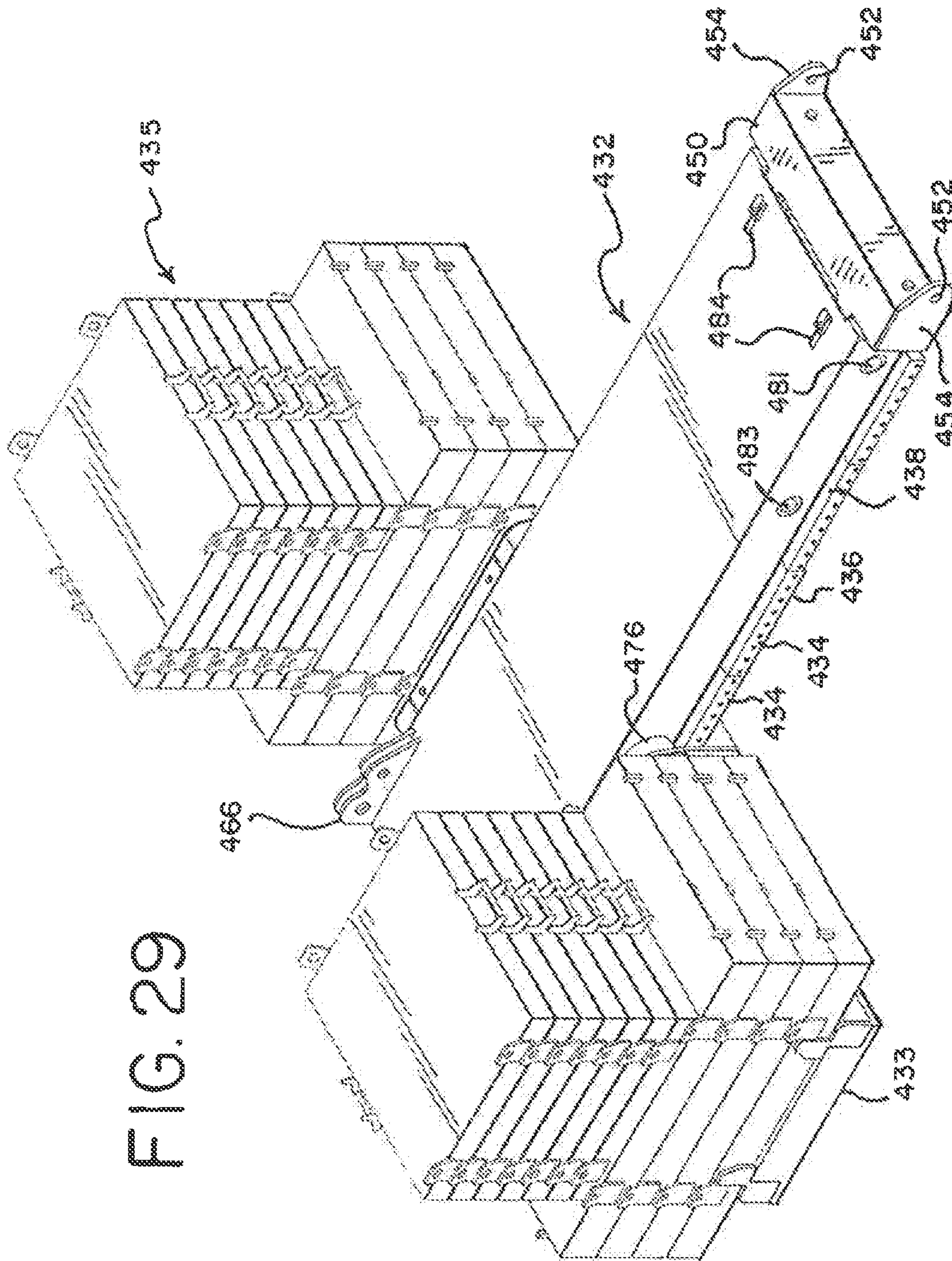
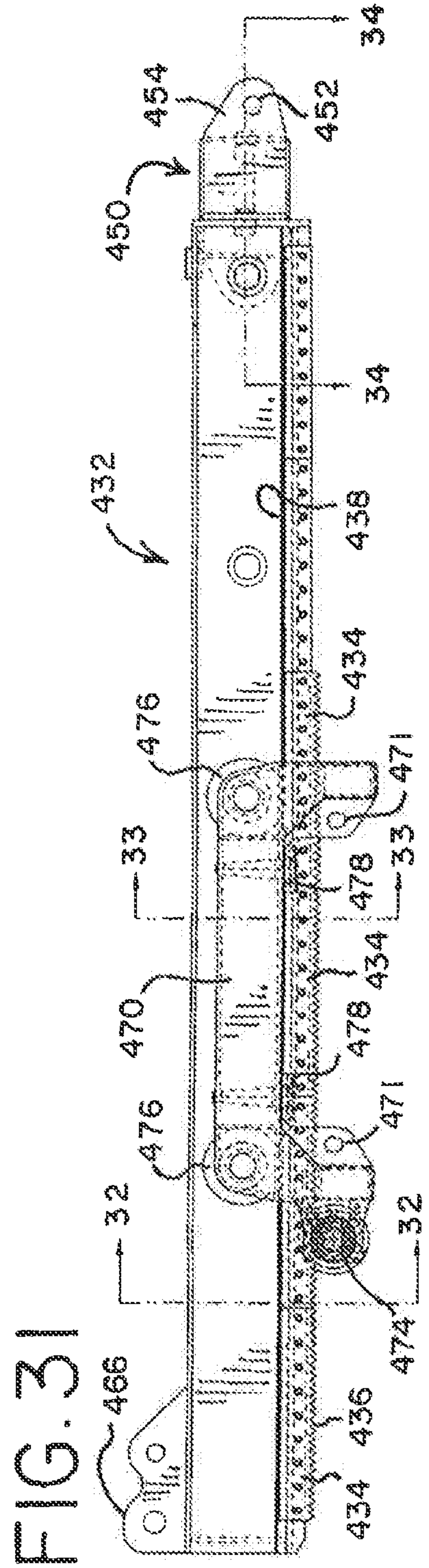
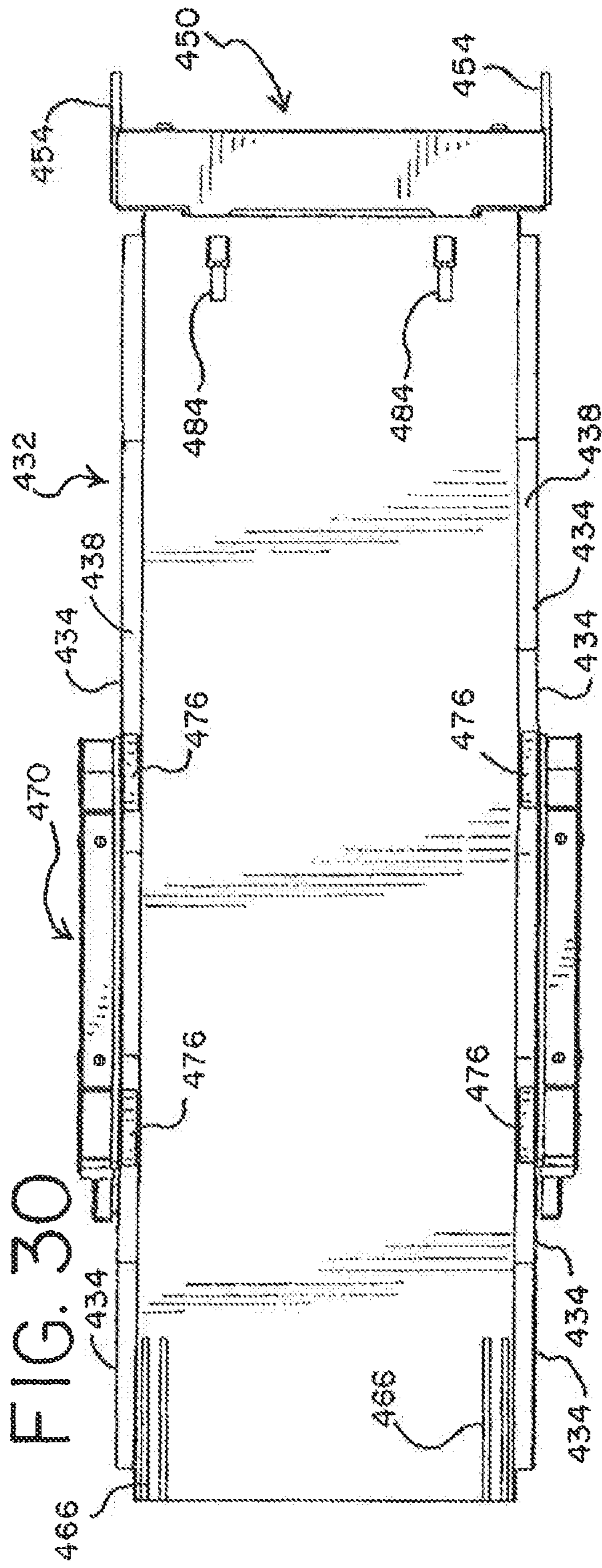

FIG. 29



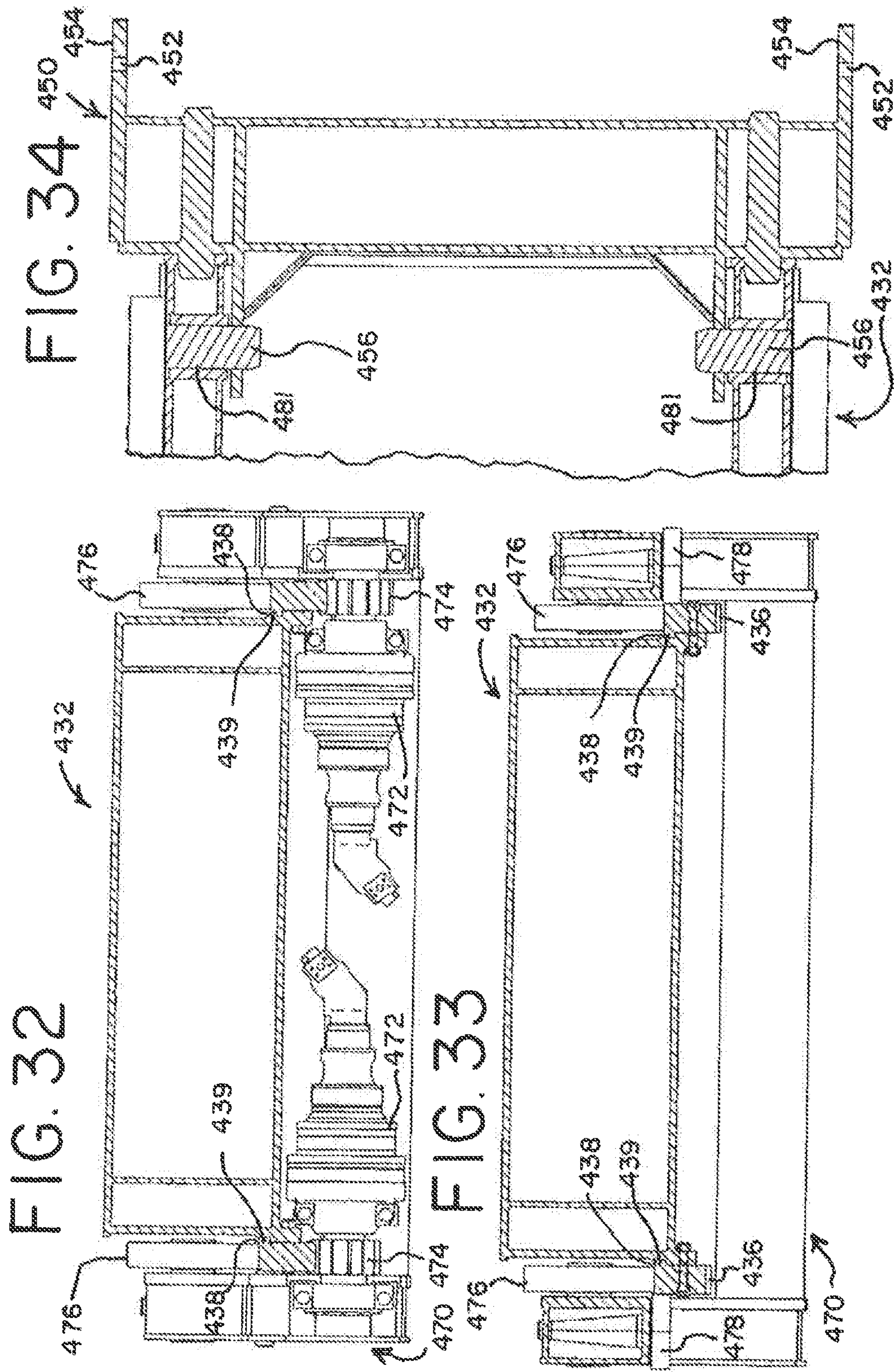

FIG. 35

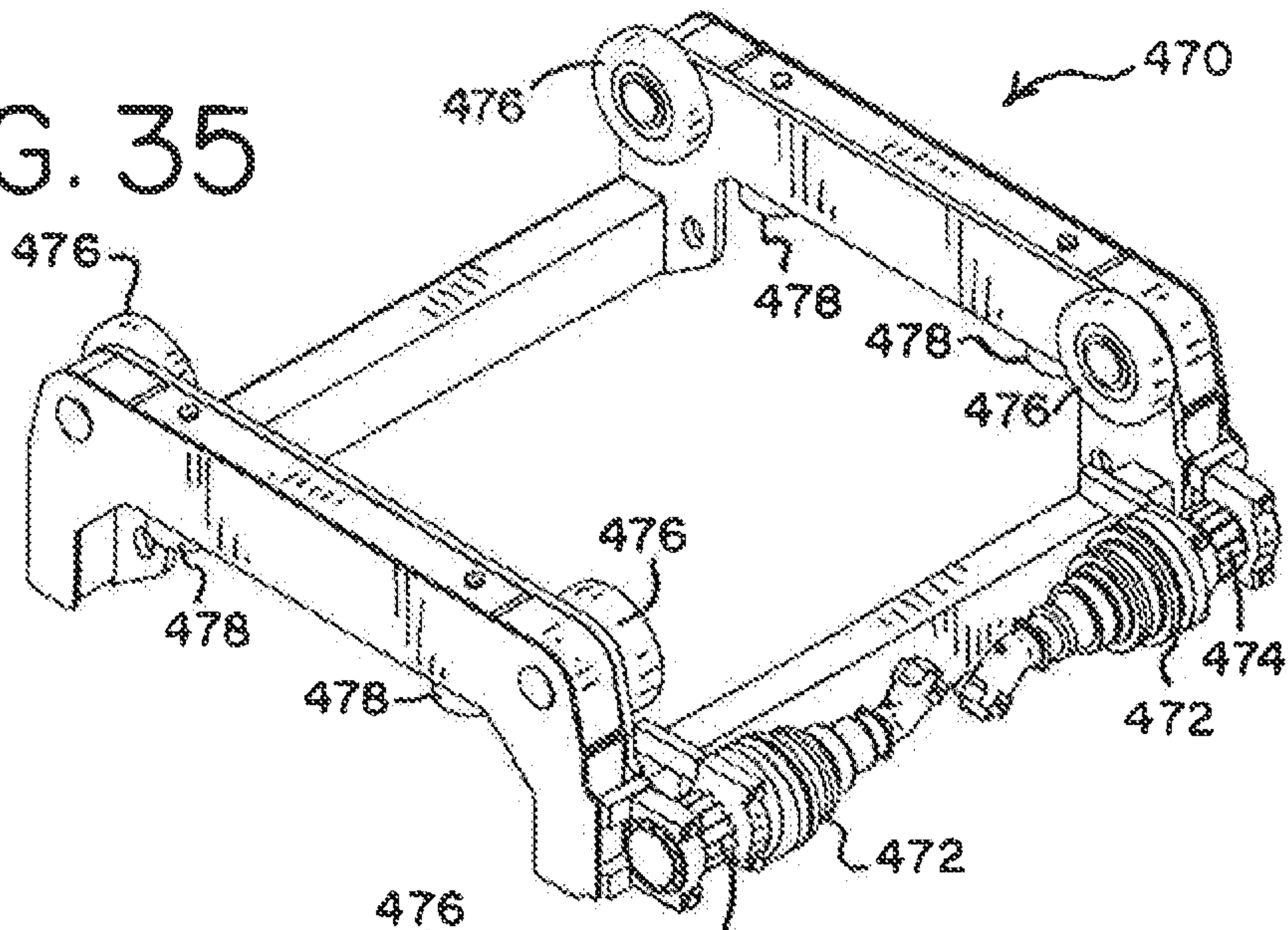

FIG. 36

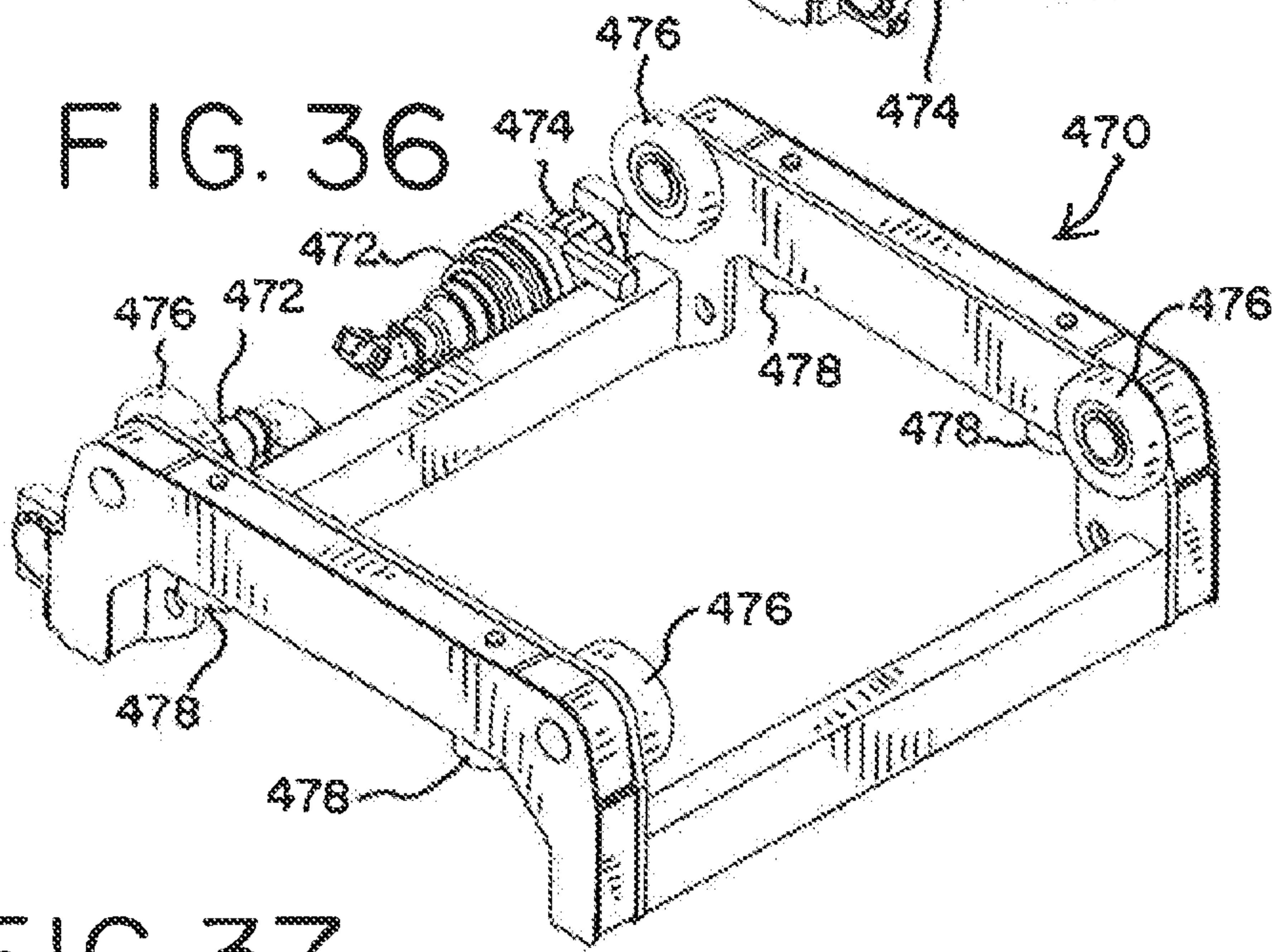

FIG. 37

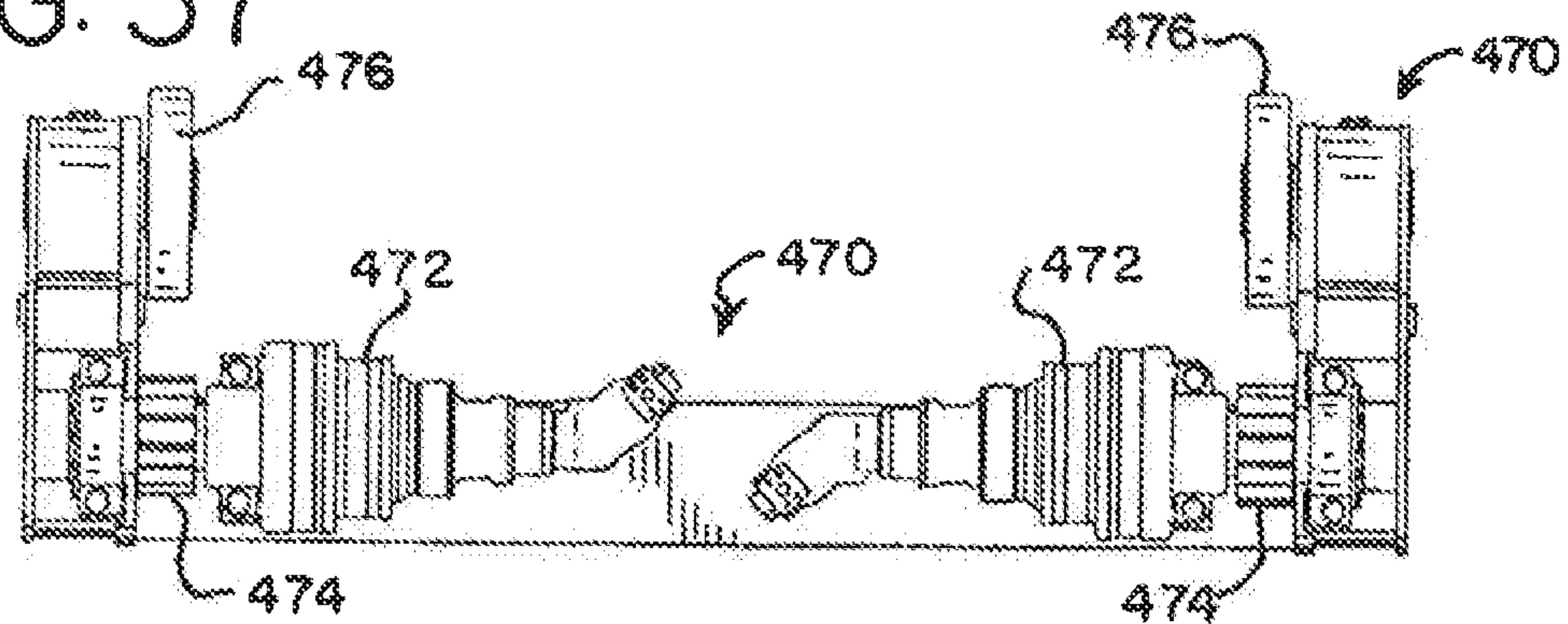
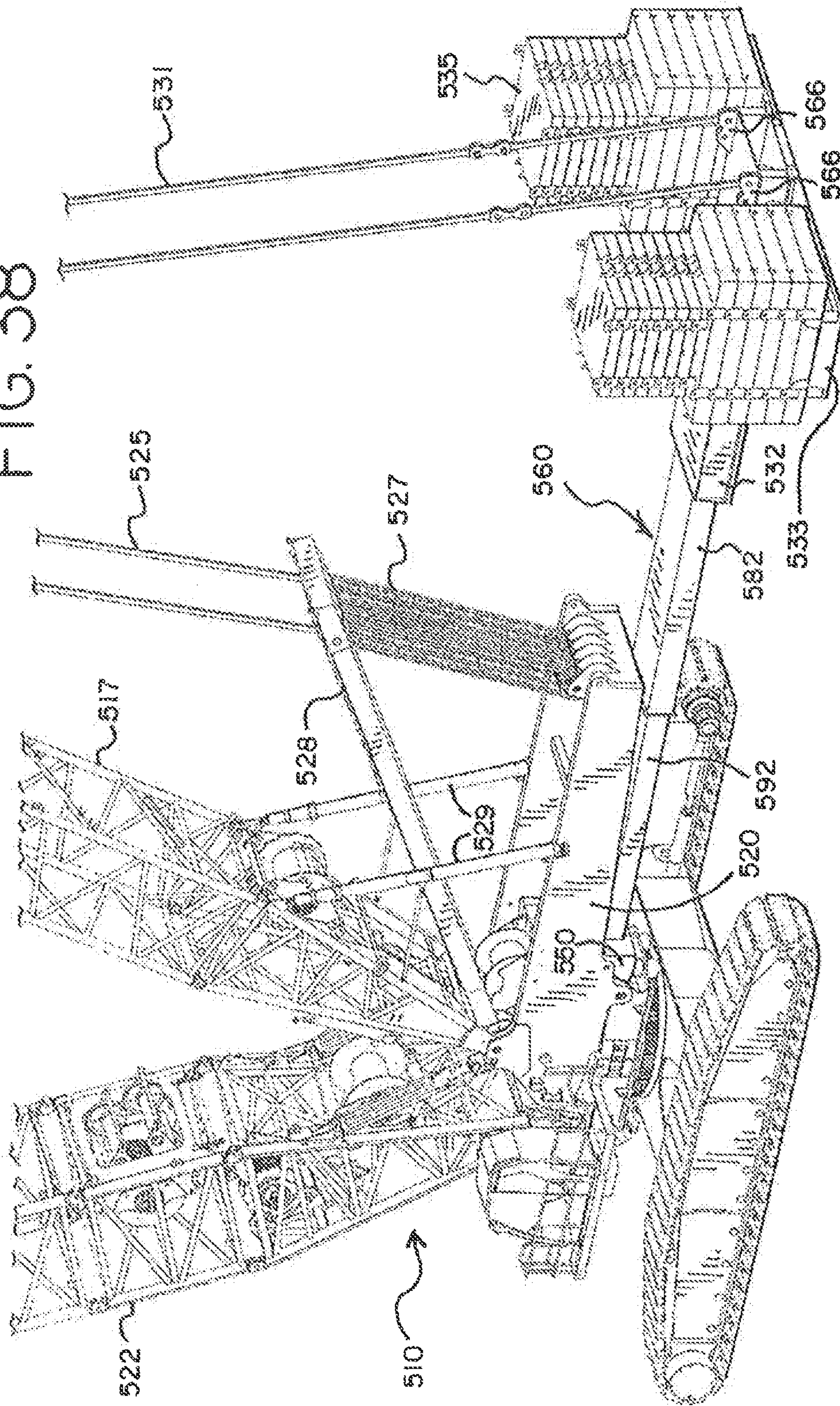

FIG. 38



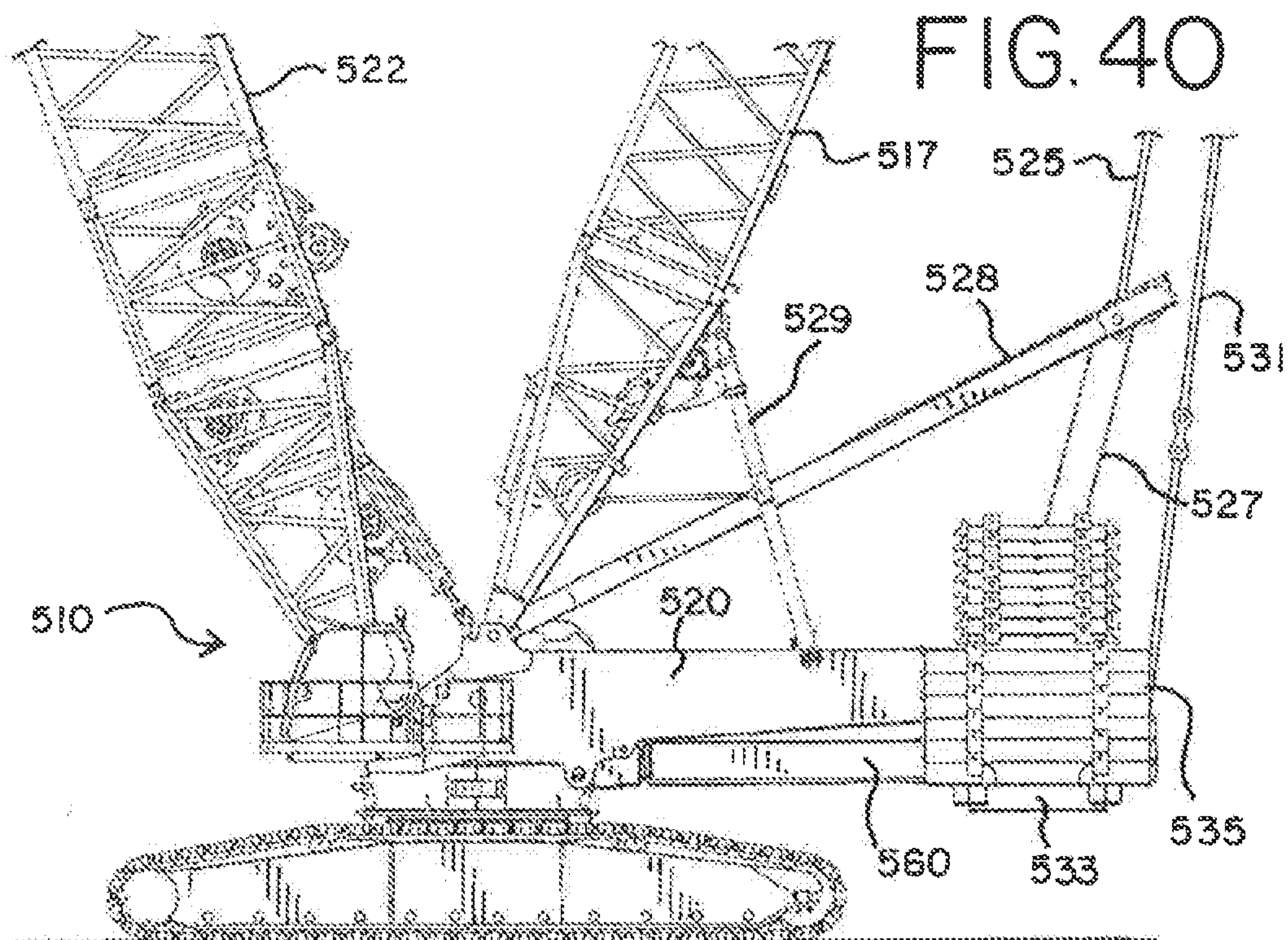
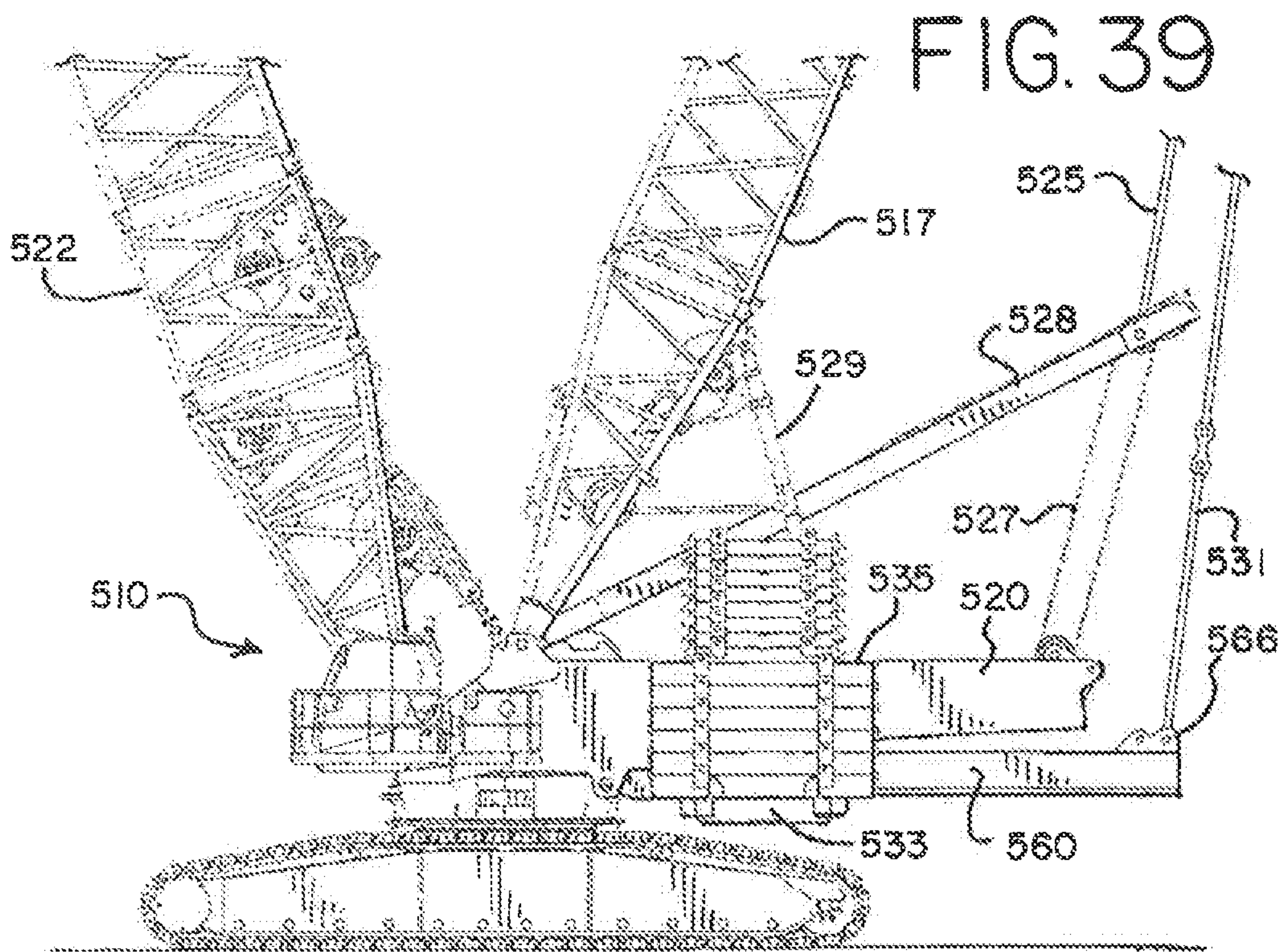
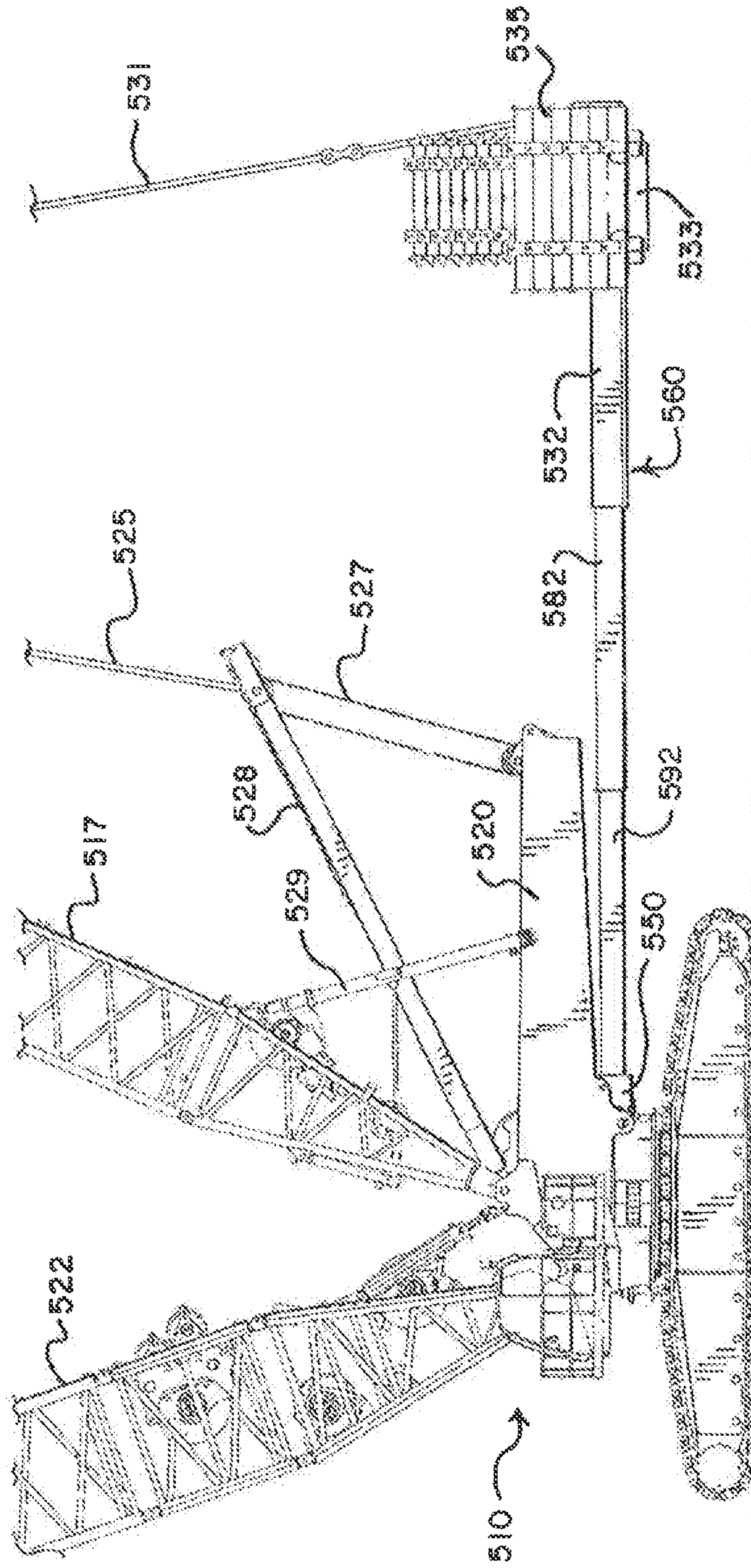

FIG. 41



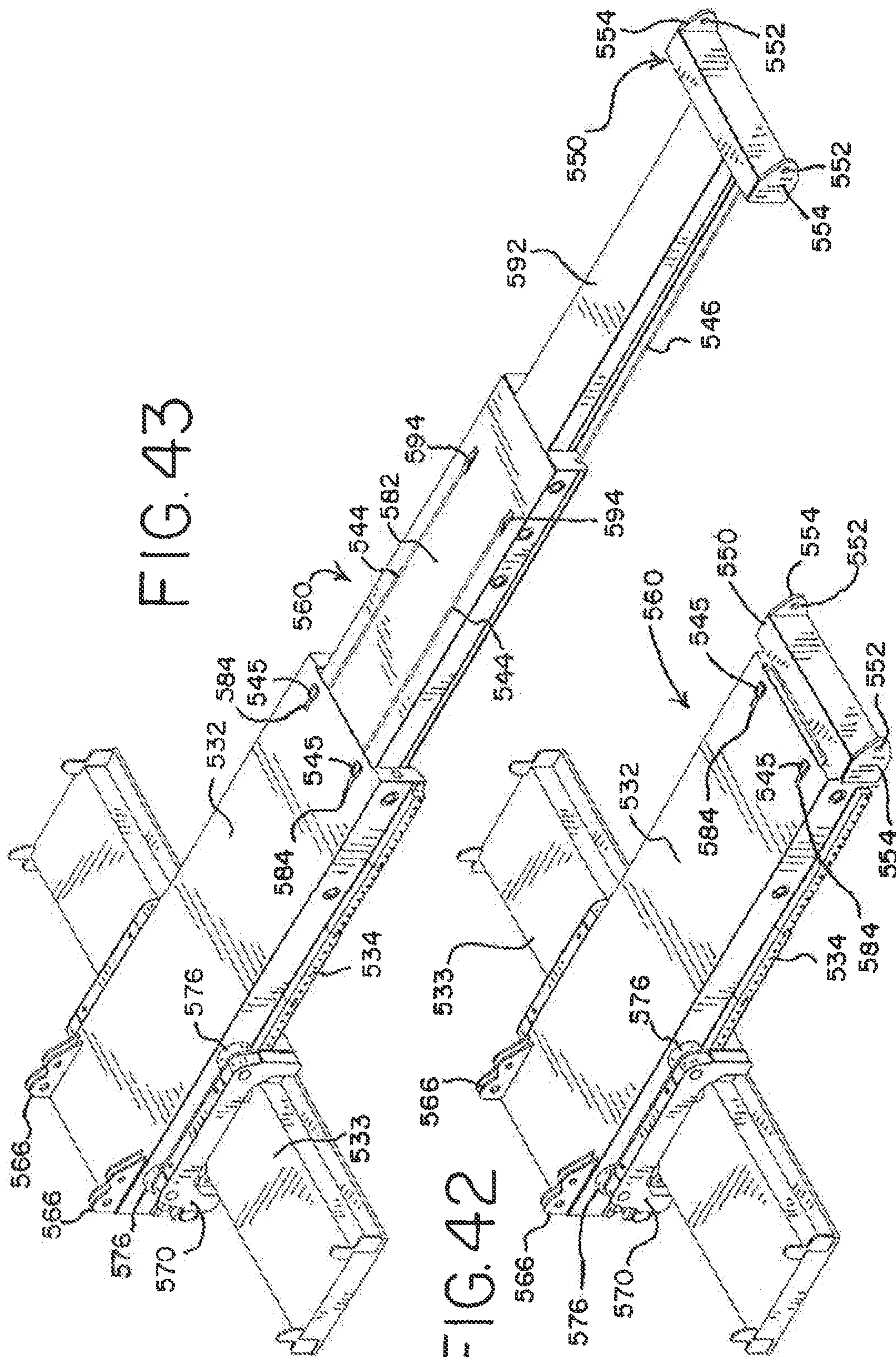
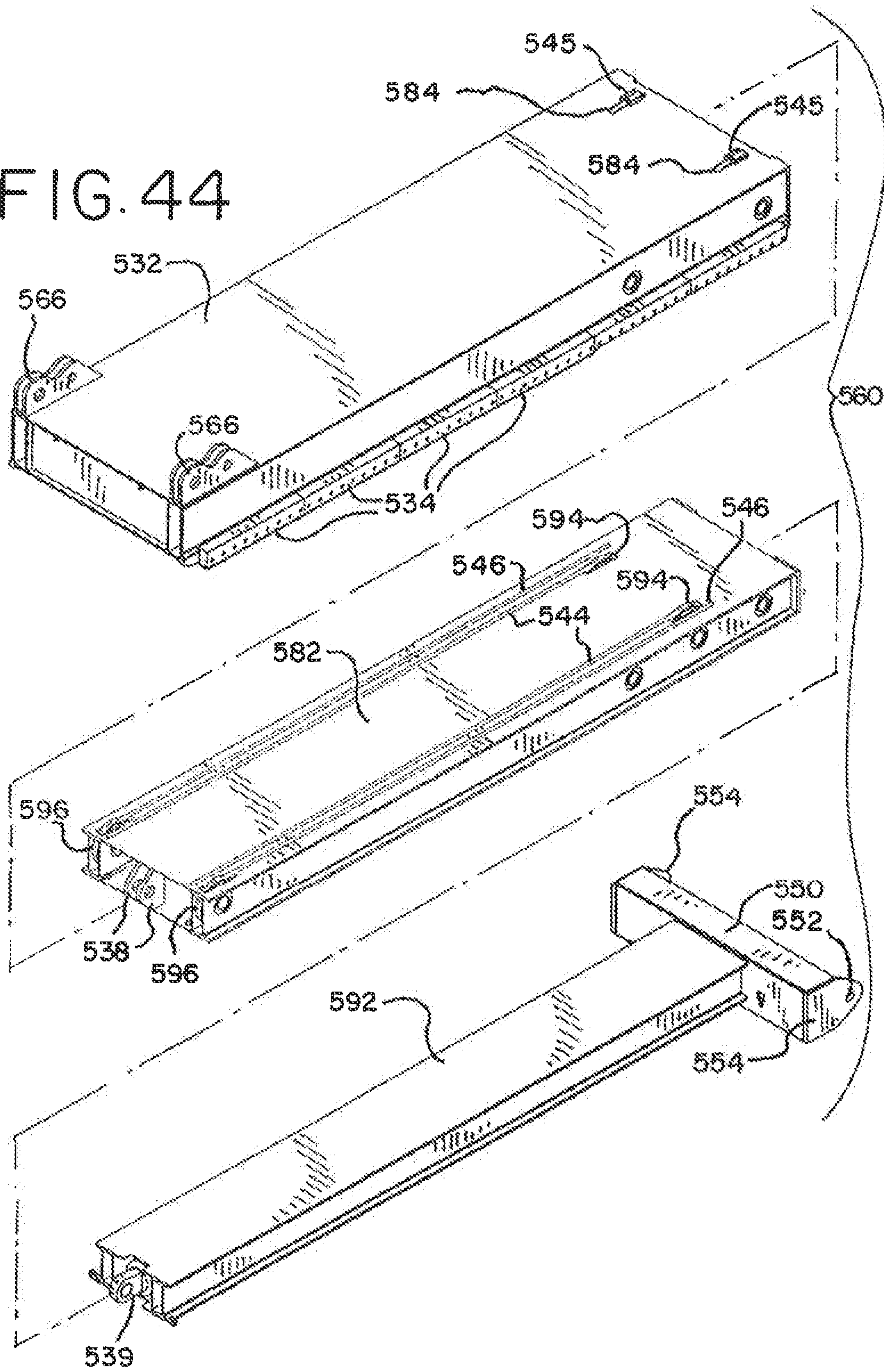
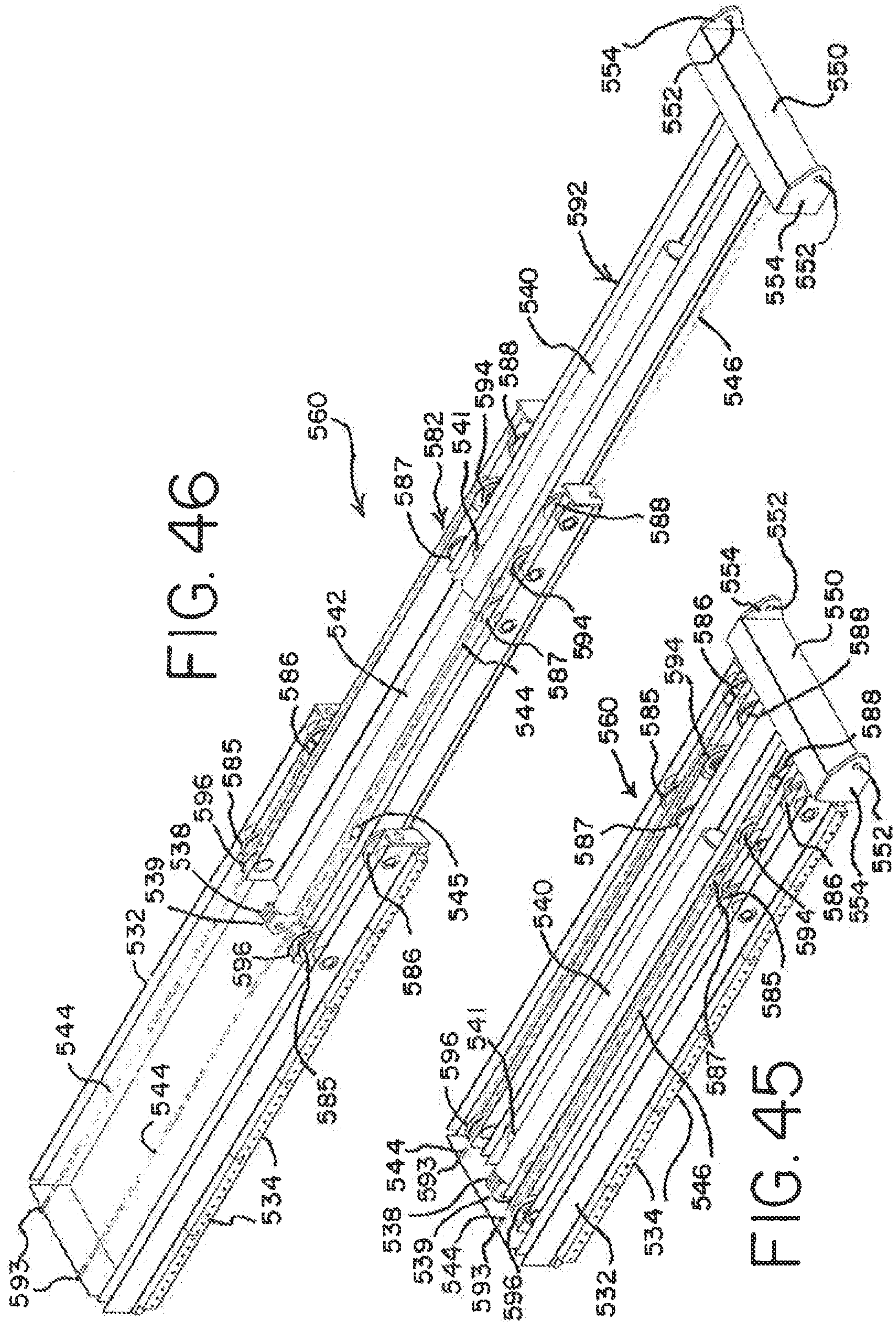

FIG. 43

FIG. 42

FIG. 44





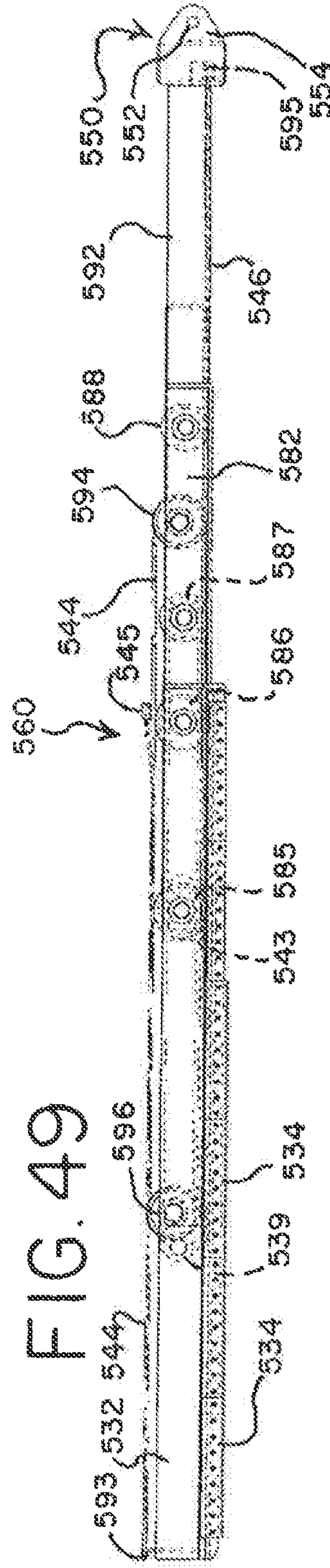
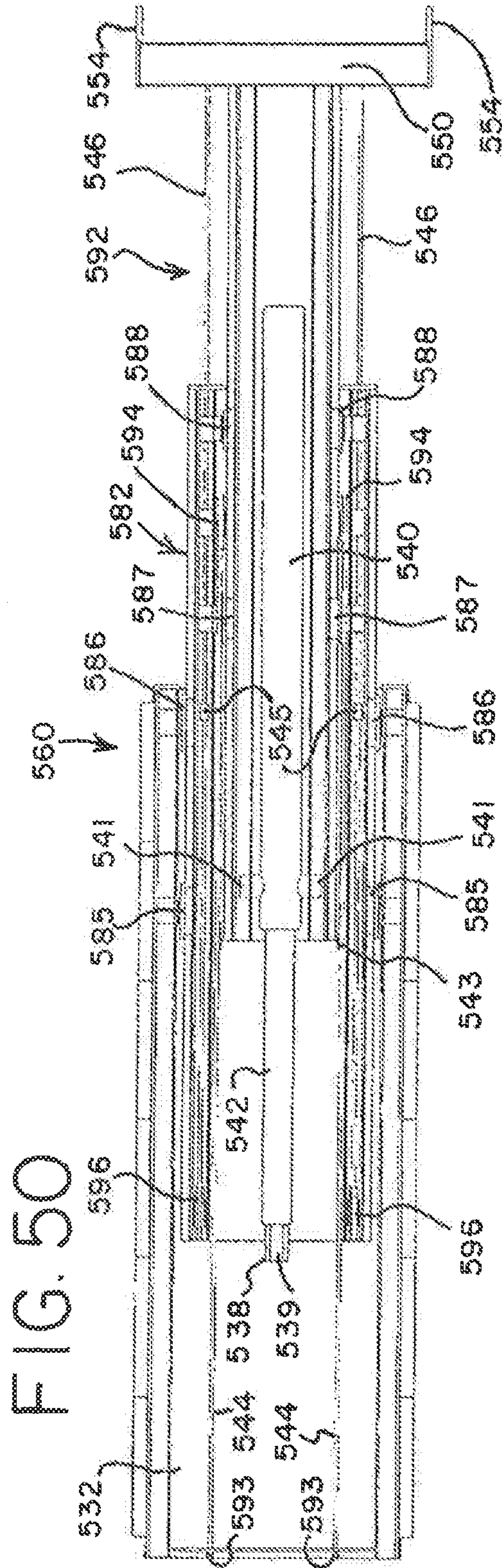

FIG. 53

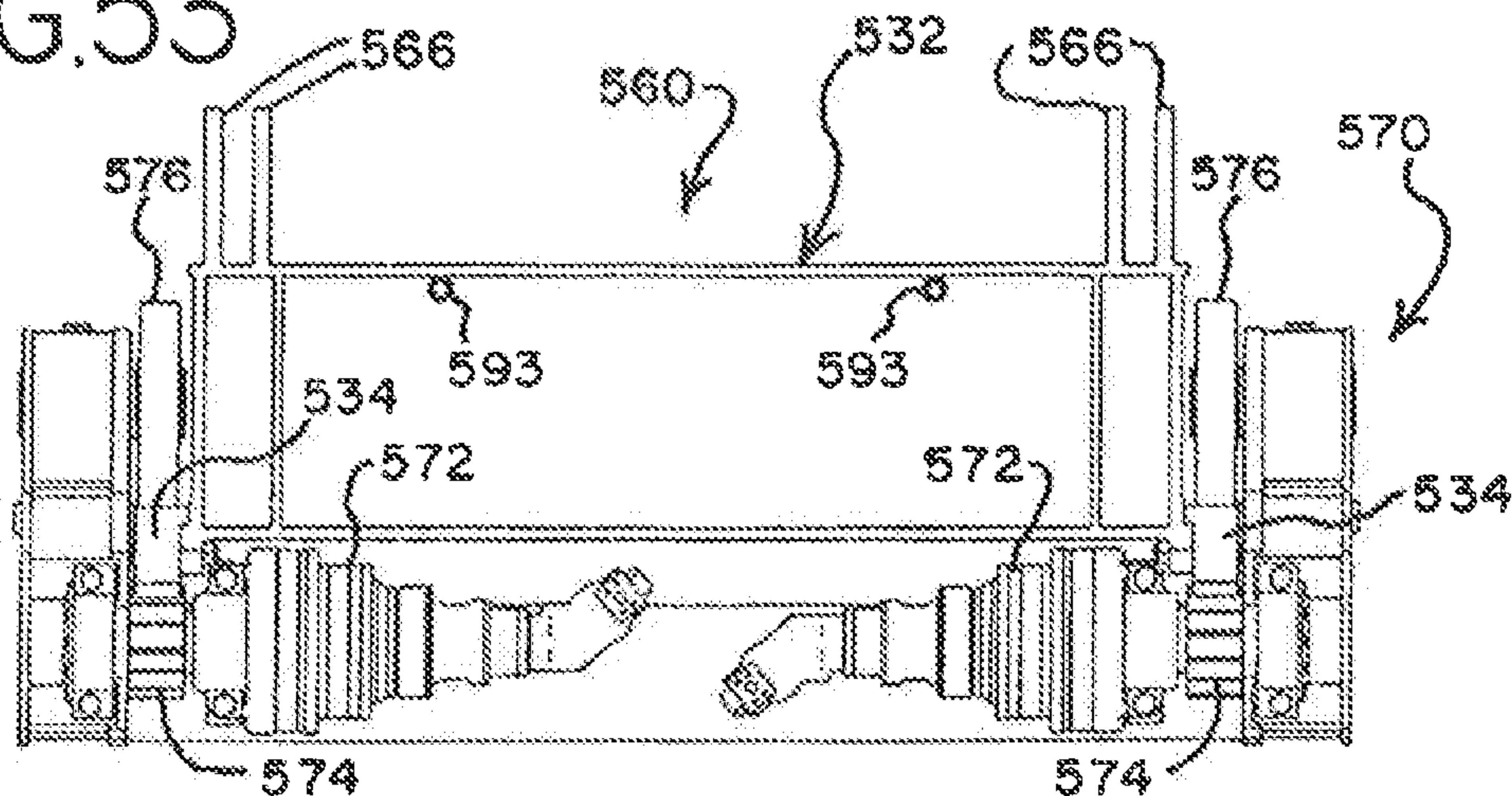

FIG. 54

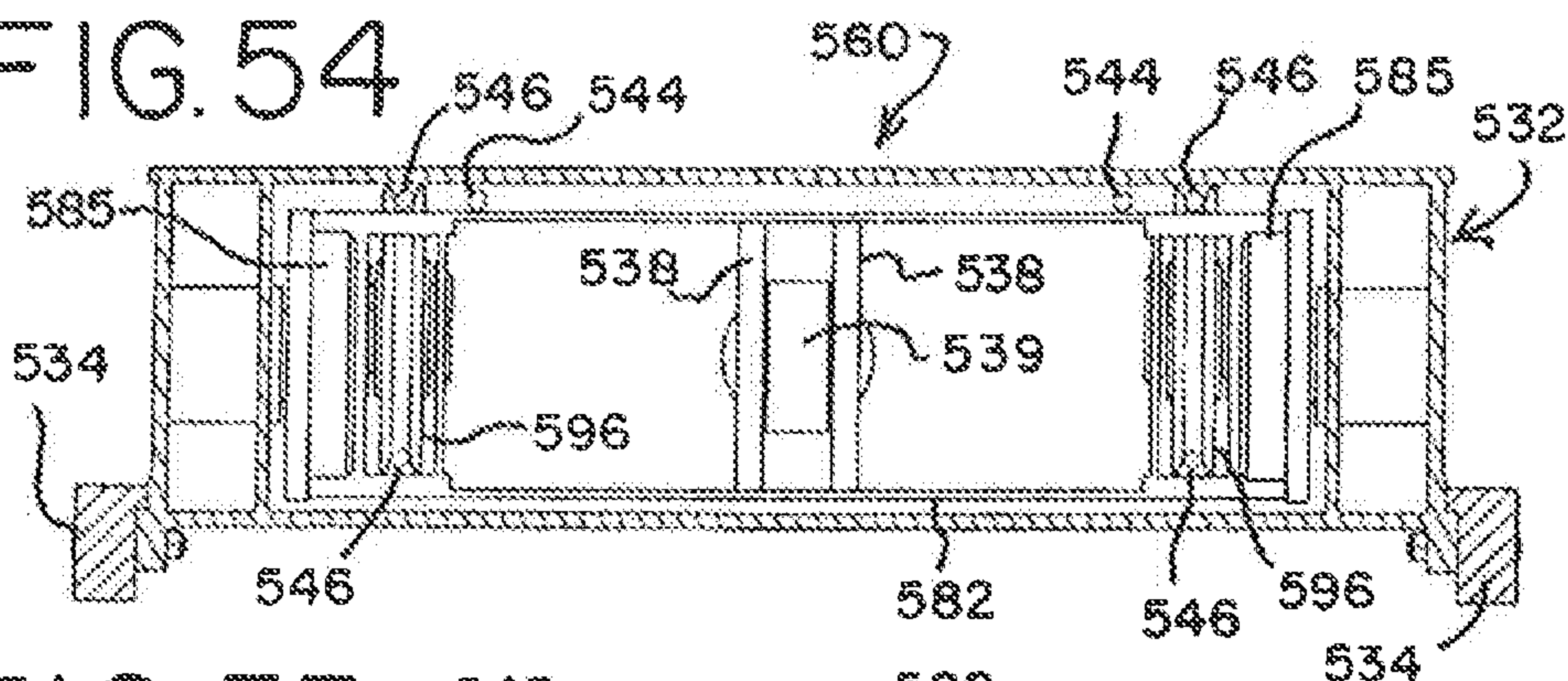

FIG. 55

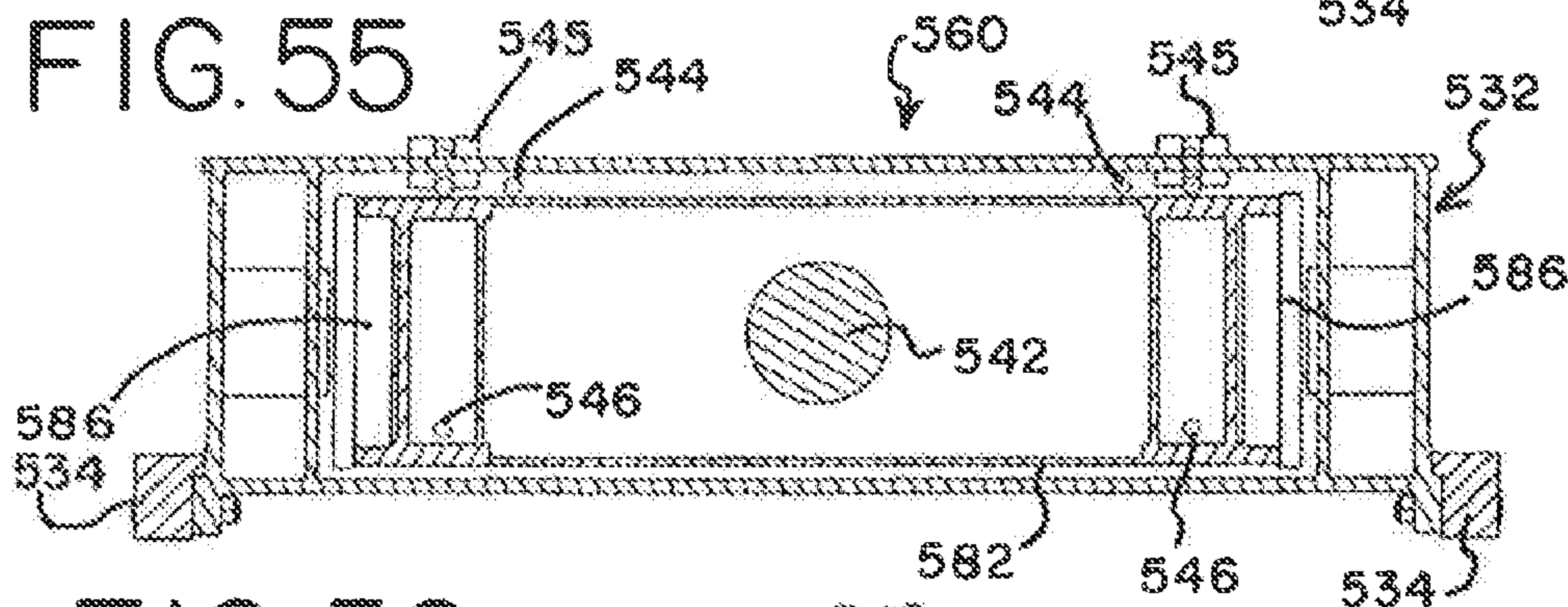

FIG. 56

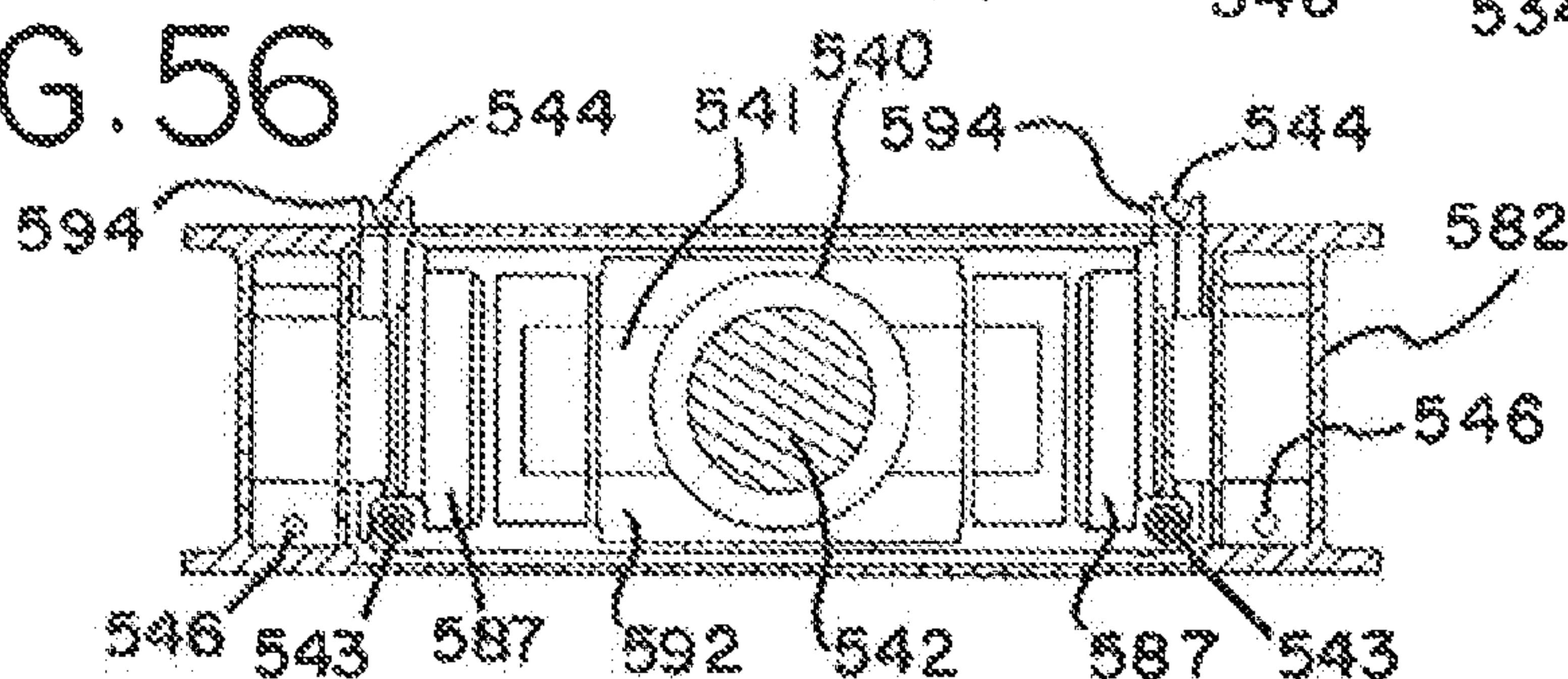

FIG. 57

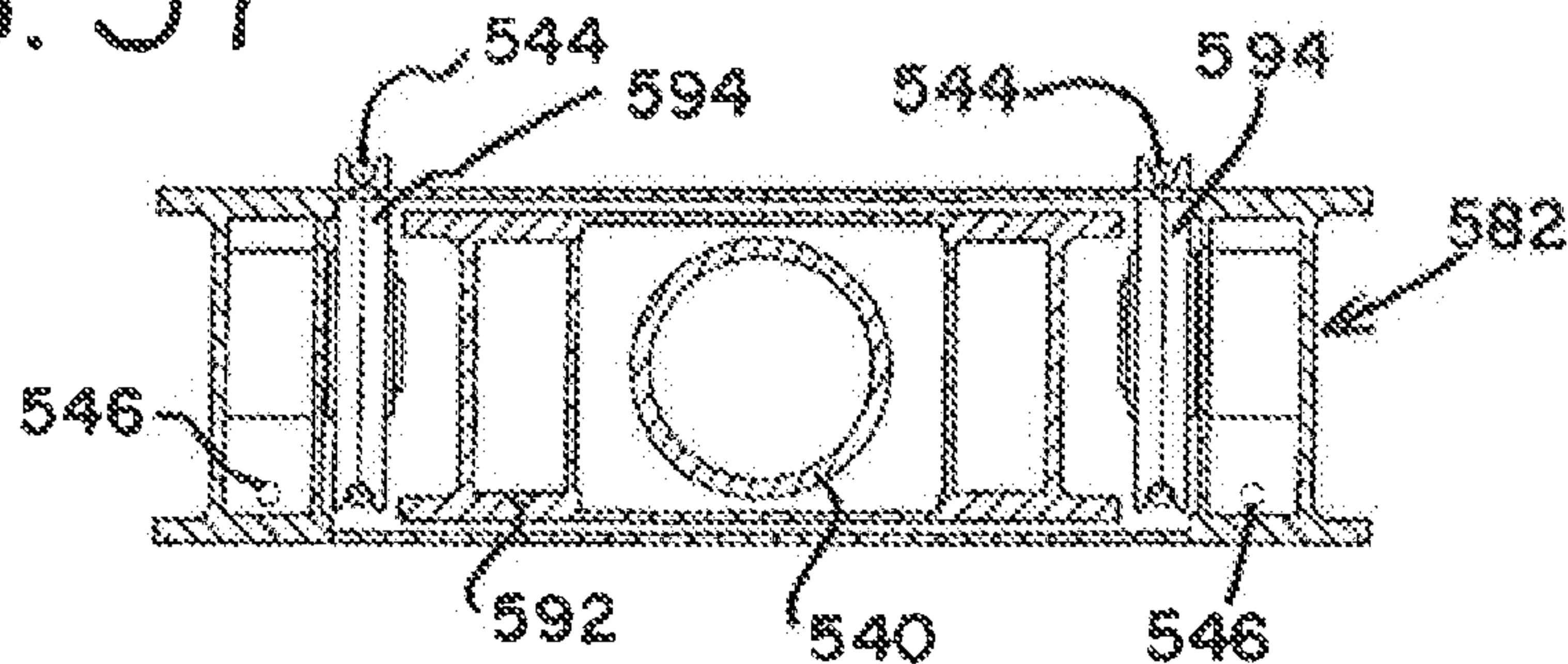

FIG. 58

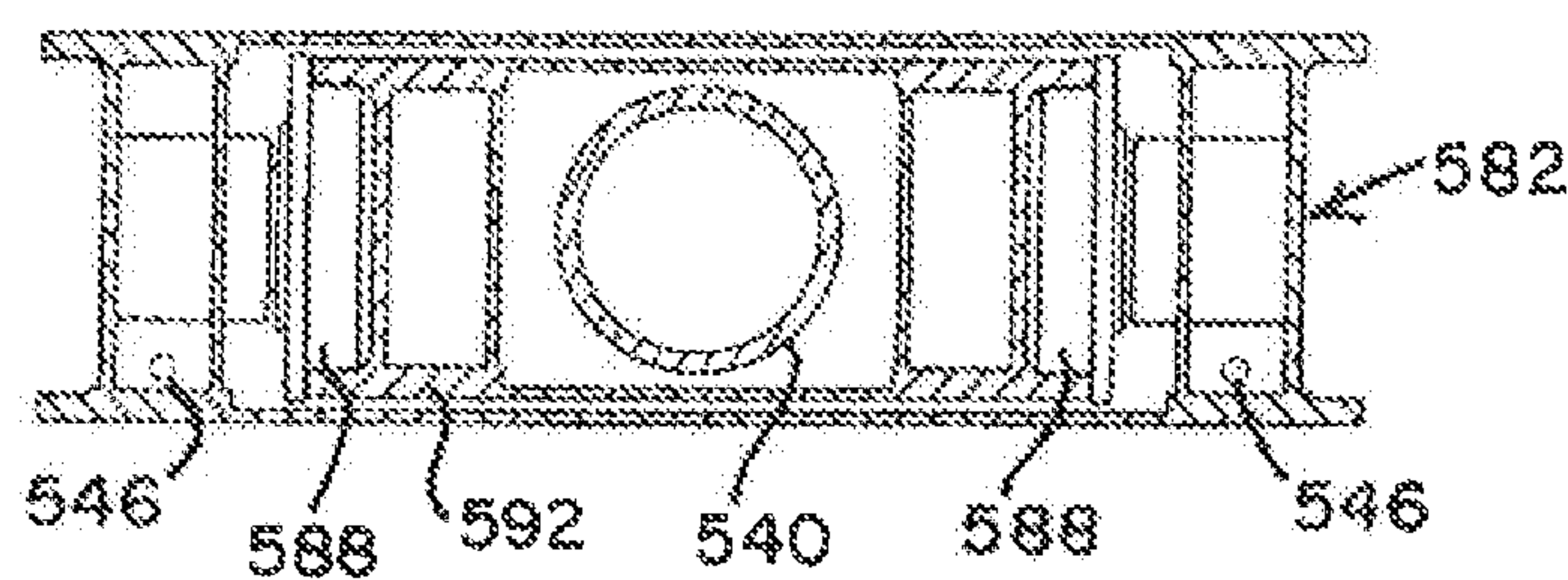

FIG. 59

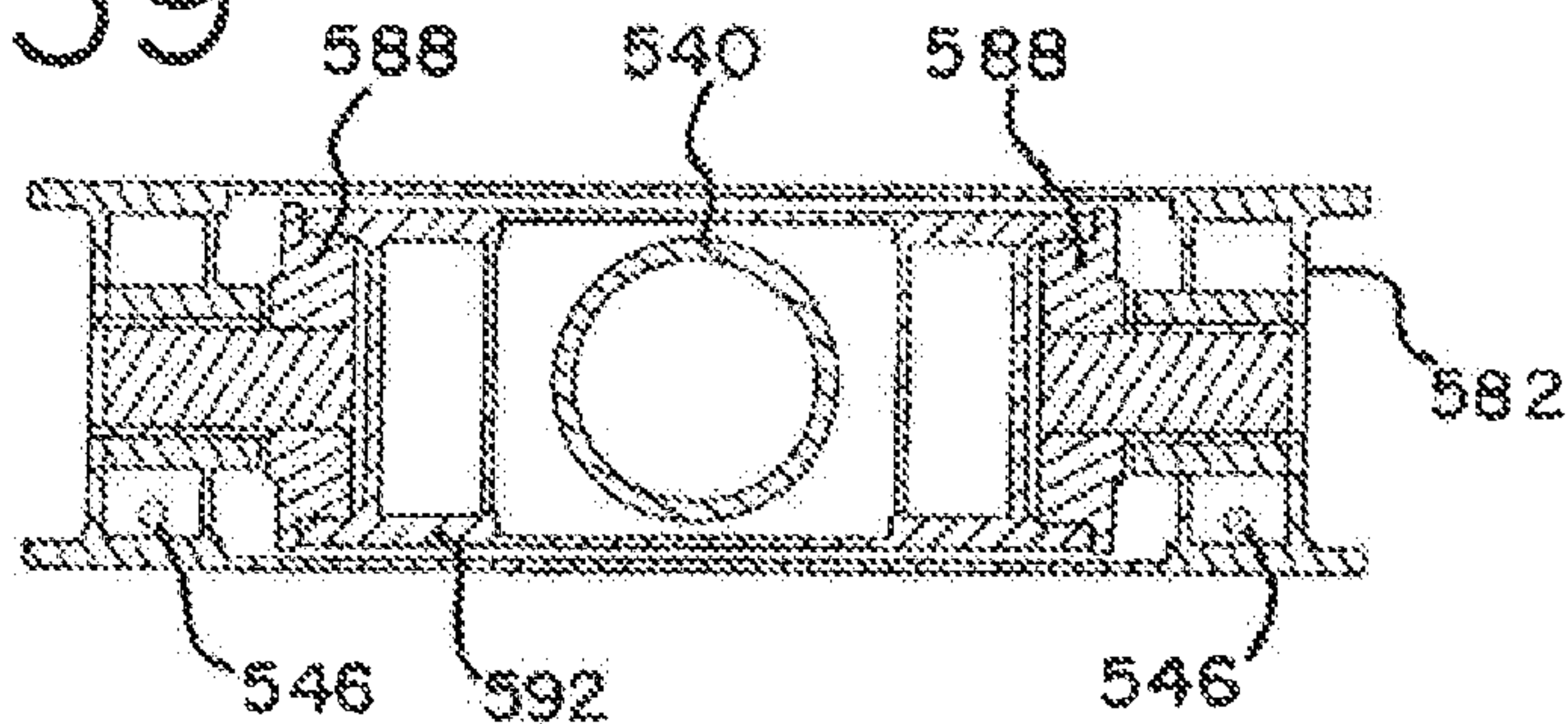
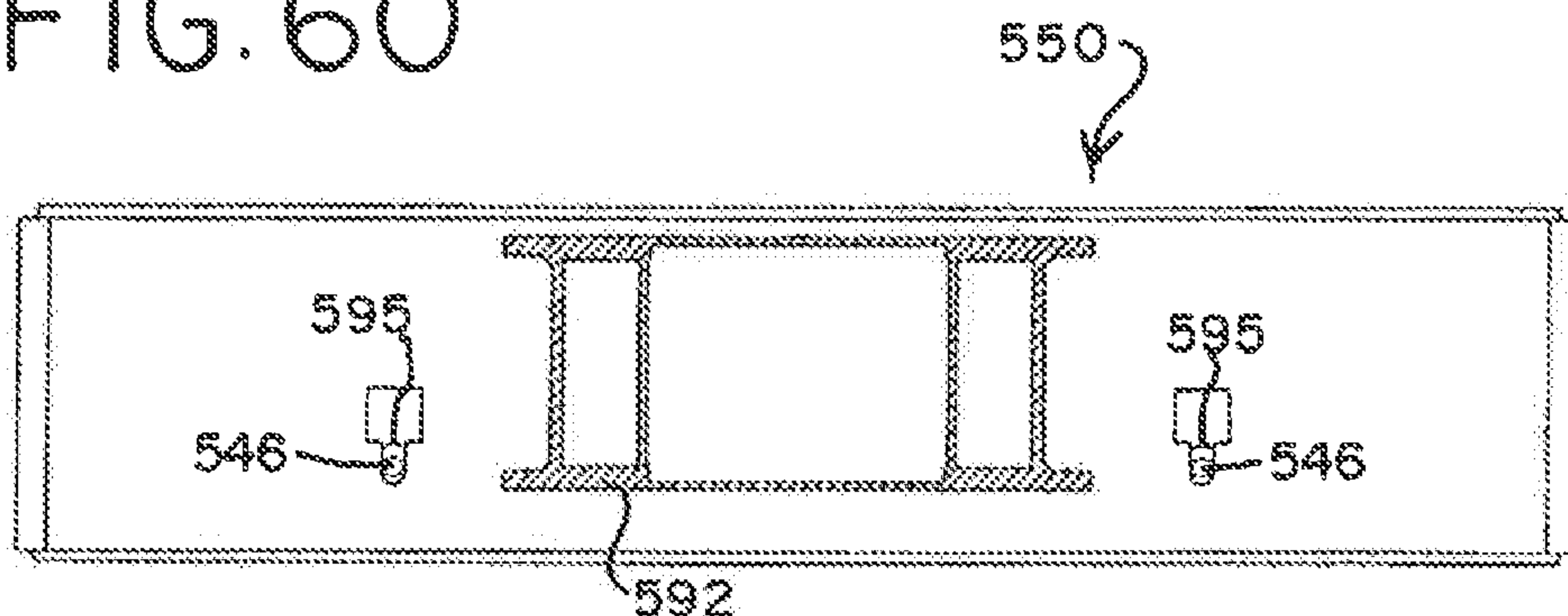

FIG. 60



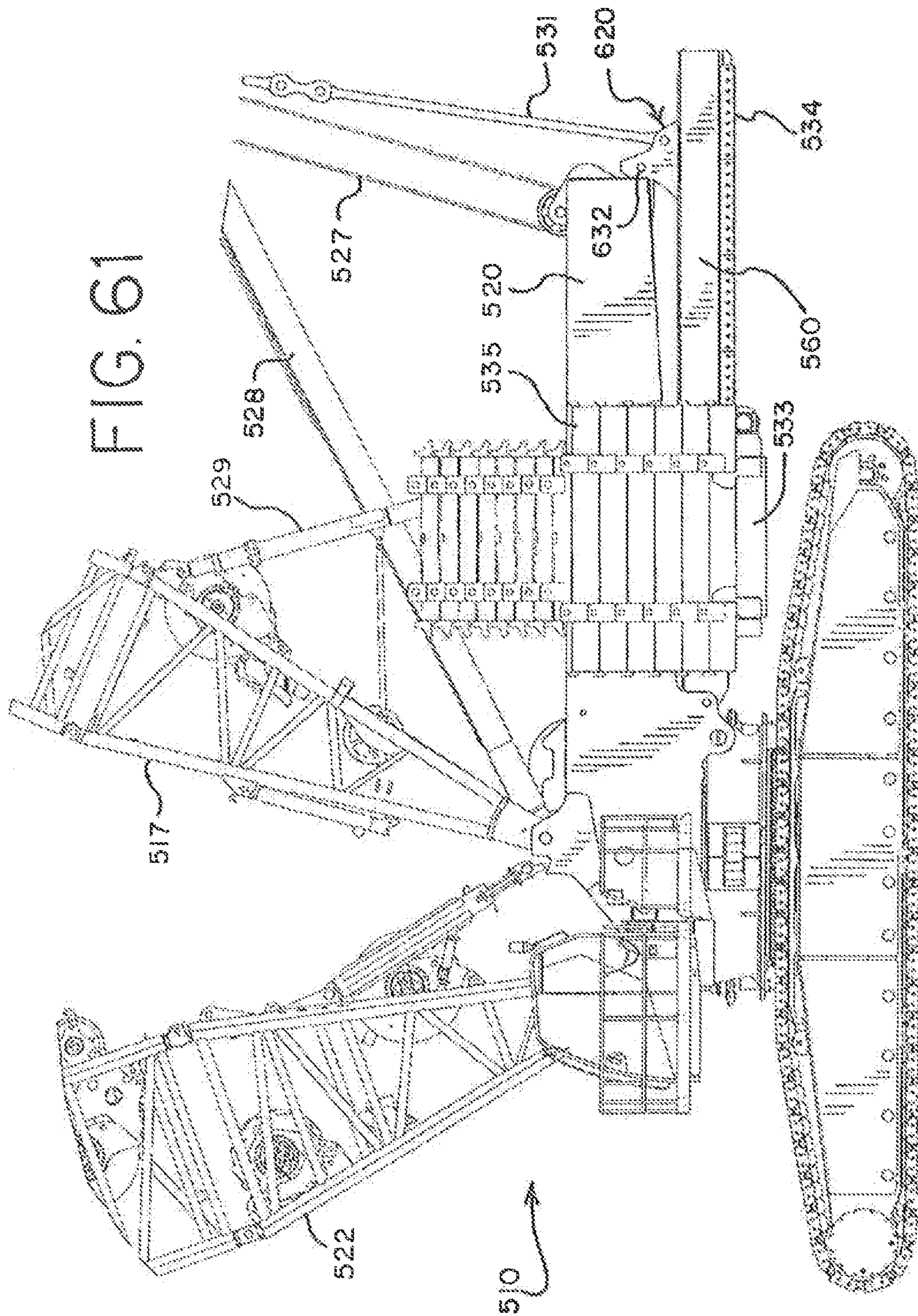
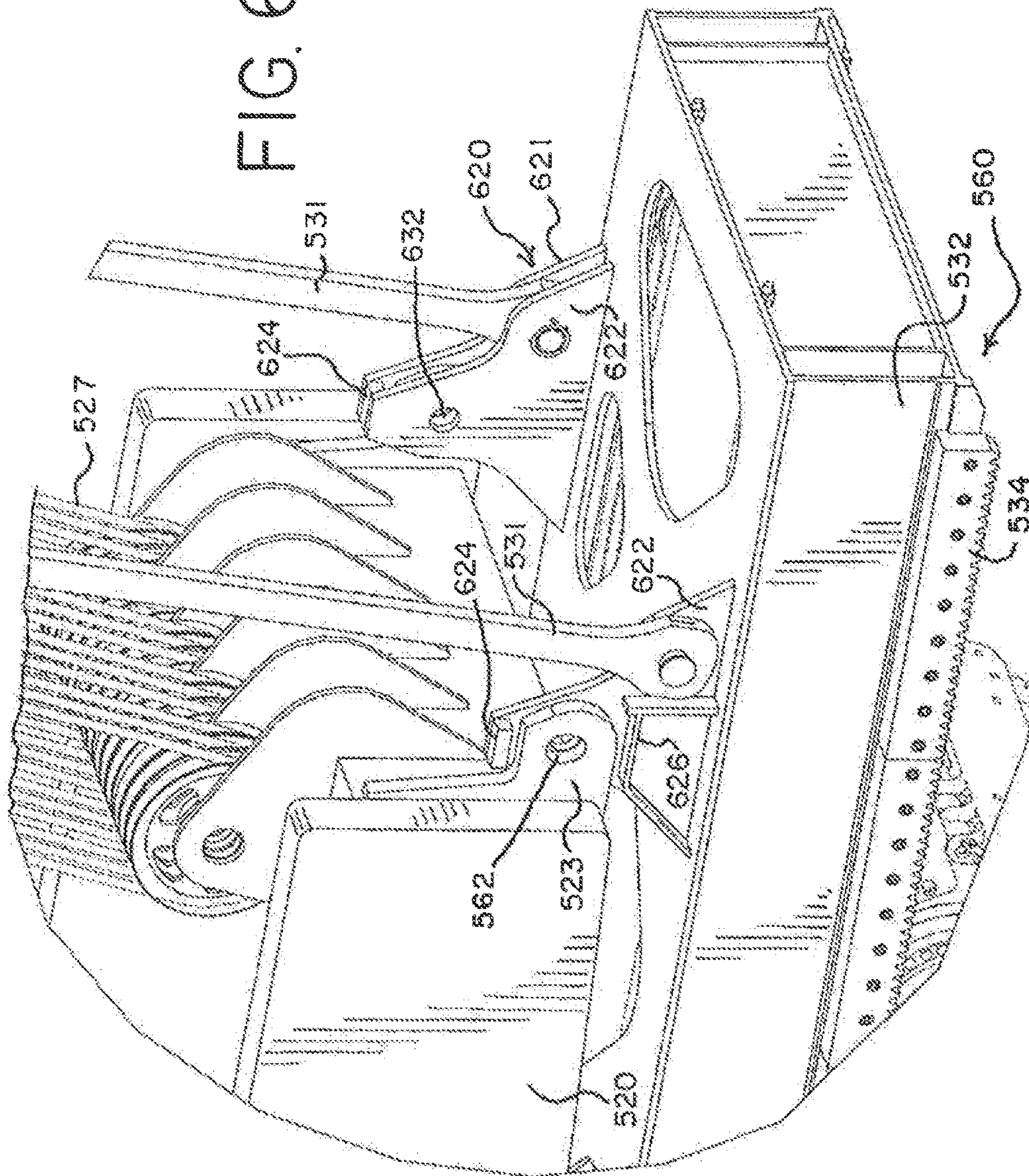

FIG. 62



1

LIFT CRANE WITH MOVEABLE COUNTERWEIGHT

REFERENCE TO EARLIER FILED APPLICATIONS

The present application is a continuation of U.S. patent application Ser. No. 12/847,902 filed Jul. 30, 2010, which claims the benefit of the filing date under 35 U.S.C. § 119(e) of Provisional U.S. Patent Application Ser. No. 61/231,884 filed Aug. 6, 2009 and of Provisional U.S. Patent Application Ser. No. 61/365,217 filed Jul. 16, 2010; all of which are hereby incorporated by reference in their entirety.

BACKGROUND

The present application relates to lift cranes, and particularly to mobile lift cranes having a counterweight that can be moved to different positions in an effort to balance the combined boom and load moment on the crane.

Lift cranes typically include counterweights to help balance the crane when the crane lowers its boom and/or lifts a load. Sometimes the counterweight on the rear of the crane is so large that the carbody is also equipped with counterweight to prevent backward tipping when no load is being lifted. Further, an extra counterweight attachment, such as a counterweight trailer, is sometimes added to the crane to further enhance the lift capacities of the mobile lift crane. Since the load is often moved in and out with respect to the center of rotation of the crane, and thus generates different moments throughout a crane pick, move and set operation, it is advantageous if the counterweight, including any extra counterweight attachments, can also be moved forward and backward with respect to the center of rotation of the crane. In this way a smaller amount of counterweight can be utilized than would be necessary if the counterweight had to be kept at a fixed distance.

A typical example of the forgoing is a Terex Demag CC8800 crane with a Superlift attachment. This crane includes 100 metric tonne of carbody counterweight, 280 metric tonne of upperworks counterweight, and 640 metric tonne on an extra counterweight attachment, for a total of 1020 metric tonne of counterweight. The extra counterweight can be moved in and out by a telescoping member. While all of this counterweight makes it possible to lift heavy loads, the counterweight has to be transported whenever the crane is dismantled for moving to a new job site. With U.S. highway constraints, it takes 15 trucks to transport 300 metric tonne of counterweight.

Since the crane needs to be mobile, any extra counterweight attachments also need to be mobile. However, when there is no load on the hook, it is customary to support these extra counterweights on the ground apart from the main crane; otherwise the extra counterweight would generate such a moment that the crane would tip backward. Thus, if the crane needs to move without a load on the hook, the extra counterweight attachment also has to be able to travel over the ground. This means that the ground has to be prepared and cleared, and often timbers put in place, for swing or travel of the extra counterweight unit. Thus there would be a benefit to a crane design that has moveable counterweight that does not need to be supported by the ground except through the crawlers on the crane.

U.S. Pat. No. 7,546,928 discloses several embodiments of mobile lift cranes with a variable position counterweight that have high capacities with lower amounts of counterweight, and the moveable counterweight does not need to be sup-

2

ported by the ground. While these embodiments are great improvements in the high-capacity crane design, there are cranes with lower capacities for which it would also be desirable to increase the capacity of the crane without increasing the total counterweight of the crane, especially if the counterweight did not need to be supported by the ground during crane operation. Further, the cranes in the '928 patent include a fixed position lattice mast structure from which the counterweight is suspended by a tension member. Sometimes it is beneficial if the mobile lift crane does not have a fixed mast structure, since the lattice mast structure requires additional components to be delivered to a job site, and a high fixed mast is sometimes an obstacle requiring clearance when the crane is repositioned. Thus there is a need for further improvements in counterweight systems for mobile lift cranes.

BRIEF SUMMARY

A mobile lift crane and method of operation has been invented for smaller capacity cranes that use a reduced amount of total counterweight compared to other cranes of the same capacity, but wherein the crane is still mobile and can lift loads comparable to a crane using significantly more total counterweight. In a first aspect, the invention is a lift crane comprising: a carbody, moveable ground engaging members mounted on the carbody allowing the crane to move over the ground; a rotating bed rotatably connected to the carbody about an axis of rotation, the rotating bed comprising a counterweight support frame; a boom pivotally mounted about a fixed boom hinge point on the front portion of the rotating bed and including a load hoist line for handling a load; a boom hoist system connected to the rotating bed and the boom that allows the angle of the boom relative to the plane of rotation of the rotating bed to be changed; a counterweight unit supported on the counterweight support frame in a moveable relationship with respect to the counterweight support frame; and a counterweight unit movement device connected between the rotating bed and the counterweight unit so as to be able to move the counterweight unit toward and away from the boom; wherein the crane is configured such that during crane operation, when the counterweight unit is moved to compensate for changes in the combined boom and load moment, the moment generated by the counterweight unit acts on the rotating bed predominantly through the counterweight support frame.

In a second aspect, the invention is a lift crane comprising: a carbody; ground engaging members elevating the carbody off the ground; a rotating bed rotatably connected to the carbody about an axis of rotation, the rotating bed having a rearmost fixed portion; a boom pivotally mounted on the front portion of the rotating bed and including a load hoist line for handling a load; a mast connected to the rotating bed, and adjustable-length boom hoist rigging connected between the mast and the boom that allows the angle of the boom relative to the plane of rotation of the rotating bed to be changed; a counterweight support beam moveably connected to the rotating bed; a counterweight support beam movement device connected between the counterweight support beam and the rotating bed such that the counterweight support beam can be moved with respect to the length of the rotating bed away from the rotational connection of the rotating bed and the carbody, and extend rearwardly of the rearmost fixed portion of the rotating bed; a tension member connected between the mast and the counterweight support beam; a counterweight unit supported on

3

the counterweight support beam in a moveable relationship with respect to the counterweight support beam; and a counterweight unit movement device connected between the counterweight support beam and the counterweight unit so as to be able to move the counterweight unit toward and away from the boom; wherein the counterweight unit may be moved to and held at a position in front of the top of the mast and moved to and held at a position rearward of the top of the mast.

A third aspect of the invention is a mobile lift crane comprising, when set up, a carbody having moveable ground engaging members; a rotating bed rotatably connected to the carbody such that the rotating bed can swing about an axis of rotation with respect to the ground engaging members; and a boom pivotally mounted on a front portion of the rotating bed, with a hoist line extending there from; wherein the crane is configured to be set up with two different counterweight set-up configuration options: i) a first counterweight set-up configuration option wherein a first counterweight movement system can move a first counterweight unit between a first position and a second position, wherein the first position is a position in which the first counterweight unit is as near as possible to the axis of rotation for the first counterweight set-up configuration option, constituting a first distance from the axis of rotation, and where the second position is a position in which the first counterweight unit is as far as possible from the axis of rotation for the first counterweight set-up configuration option, constituting a second distance from the axis of rotation; and ii) a second counterweight set-up configuration option wherein a second counterweight movement system can move a second counterweight unit between a third position and a fourth position, where the third position is a position in which the second counterweight unit is as near as possible to the axis of rotation for the second counterweight set-up configuration option, constituting a third distance from the axis of rotation, and where the fourth position is a position in which the second counterweight unit is as far as possible from the axis of rotation in the second counterweight set-up configuration option, constituting a fourth distance from the axis of rotation; and further wherein the fourth distance is greater than the second distance, and wherein the difference between the third and fourth distances is greater than the difference between the first and second distances.

A fourth aspect of the invention is a lift crane comprising: a carbody; ground engaging members elevating the carbody off the ground; a rotating bed rotatably connected to the carbody; a counterweight support beam telescopically connected to the rotating bed such that the rear portion of the counterweight support beam can be extended away from the rotational connection of the rotating bed and the carbody; a boom pivotally mounted on the front portion of the rotating bed and including a load hoist line for handling a load; a mast connected to the rotating bed, and adjustable-length boom hoist rigging connected between the mast and the boom that allows the angle of the boom relative to the plane of rotation of the rotating bed to be changed; a tension member connected between the mast and the counterweight support beam; a counterweight unit supported on the counterweight support beam in a moveable relationship with respect to the counterweight support beam; and a counterweight movement system capable of moving the counterweight unit toward the boom to a position in front of the top of the mast and away from the boom to a position rearward of the top of the mast, the counterweight movement system causing the counterweight unit to move with respect to the

4

rear of the counterweight support beam and the rear of the counterweight support beam to move with respect to the rotating bed.

In a fifth aspect, the invention is a lift crane comprising: a carbody having moveable ground engaging members mounted on the carbody allowing the crane to move over the ground; a rotating bed rotatably connected about an axis of rotation to the carbody such that the rotating bed can swing with respect to the moveable ground engaging members; a boom pivotally mounted on the front portion of the rotating bed and including a load hoist line for handling a load; a mast pivotally mounted on the rotating bed at a first end; a boom hoist system comprising pendants connected between the mast and the boom, the boom and mast being connected together with a fixed length of rigging between the boom and the mast, and a boom hoist system mounted between the mast and the rotating bed, the boom hoist system allowing the angle of the boom relative to the plane of rotation of the rotating bed to be changed; a moveable counterweight unit supported on the rotating bed; and a counterweight movement system connected between the rotating bed and the counterweight unit so as to be able to move the counterweight unit toward and away from the boom.

In a sixth aspect, the invention is mobile lift crane comprising: a carbody having moveable ground engaging members; a rotating bed rotatably connected about an axis of rotation to the carbody such that the rotating bed can swing with respect to the moveable ground engaging members; a boom pivotally mounted on a front portion of the rotating bed; an upperworks counterweight unit that rotates with the rotating bed and is never supported by the ground during crane pick, move and set operations other than indirectly by the moveable ground engaging members on the carbody, wherein the ratio of i) the weight of the upperworks counterweight unit to ii) the total weight of the crane equipped with a basic boom length is greater than 52%.

In a seventh aspect, the invention is a method of operating a mobile lift crane, the lift crane comprising a carbody having moveable ground engaging members; a rotating bed rotatably connected to the carbody such that the rotating bed can swing with respect to the moveable ground engaging members; a boom pivotally mounted on a front portion of the rotating bed, with a hoist line extending there from; a moveable counterweight support beam; and a moveable counterweight unit supported on the moveable counterweight support beam, the method comprising: performing a pick, move and set operation with a load wherein the moveable counterweight unit is moved toward and away from the front portion of the rotating bed during the pick, move and set operation to help counterbalance the combined boom and load moment, and wherein the counterweight unit stays on the counterweight support beam during the pick, move and set operation, and the counterweight support beam and counterweight unit both move to counterbalance the crane as the combined boom and load moment changes.

In an eighth aspect, the invention is a method of increasing the capacity of a crane comprising the steps of: a) providing a lift crane having a first capacity comprising a carbody having moveable ground engaging members mounted on the carbody allowing the crane to move over the ground; a rotating bed rotatably connected about an axis of rotation to the carbody such that the rotating bed can swing with respect to the moveable ground engaging members; a boom pivotally mounted on the front portion of the rotating bed and including a load hoist line for handling a load; and a moveable counterweight unit supported on the rotating bed, the counterweight unit including multiple counter-

5

weights stacked on top of each other, the counterweight unit being moveable from a first position to a second position further from the boom than the first position; b) removing at least some of the counterweights from the crane; c) adding a counterweight support beam to the crane, attached to the rotating bed; and d) returning at least some of the counterweights removed in step b) back to the crane to provide a crane having a second capacity greater than the first capacity, with the returned counterweights being supported on the counterweight support beam in a manner that allows the returned counterweights to be able to move to a third position further from the boom than the second position.

In a ninth aspect, the invention is a mobile lift crane comprising a carbody; moveable ground engaging members mounted on the embodiment allowing the crane to move over the ground; a rotating bed rotatably connected to the carbody about an axis of rotation, the rotating bed comprising a counterweight support frame; and a boom pivotally mounted about a boom hinge point on the front portion of the rotating bed and including a hoist line for handling a load. The crane is configured for assembly in at least two configurations. In the first configuration, the crane further comprises a live mast; a first counterweight support frame; and a first moveable counterweight unit moveably connected to the first counterweight support frame, and operable to move toward and away from the boom during a pick, move, and set operation, wherein the first moveable counterweight unit is supported by the first counterweight support frame. In the second configuration, the crane further comprises a lattice mast; a second counterweight support frame; a moveable counterweight support beam coupled to the second counterweight support frame and operable to move relative to the second counterweight support frame while moving toward and away from the boom during a pick, move, and set operation; and a second moveable counterweight unit moveably connected to the moveable counterweight support beam, and operable to move toward and away from the boom and relative to the moveable counterweight support beam during a pick, move, and set operation.

With the lift crane of the present invention, a counterweight can be positioned far forward such that it produces very little backward moment on the crane when no load is on the hook. As a result, the carbody need not have extra counterweight attached to it. This large counterweight can be positioned far backward so that it can counterbalance a heavy load. On the other hand, with one embodiment of the invention the load can be lifted without the need for a lattice mast from which the counterweight is suspended. Rather, in some embodiments the rotating bed is equipped with counterweight support frame on which the counterweight unit can move backwards. Interestingly, in some embodiments, the basic model crane can also be equipped with a lattice mast and a moveable counterweight support beam to further increase the capacity of the crane. As with the large capacity crane of U.S. Pat. No. 7,546,928 of U.S., another advantage of the preferred embodiment of the invention is that the counterweight need not be set on the ground when the crane sets its load. There is no extra counterweight unit requiring a trailer, and the limitations of having to prepare the ground for such a trailer.

These and other advantages of the invention, as well as the invention itself, will be more easily understood in view of the attached drawings.

BRIEF DESCRIPTION OF THE DRAWINGS

FIG. 1 is a side elevation view of a first embodiment of a mobile lift crane with a variable position counterweight,

6

shown with the counterweight in a far forward position and, for sake of clarity, without a boom, live mast and other components traditionally found on a lift crane.

FIG. 2 is a side elevation view of the mobile lift crane of FIG. 1 with the counterweight in a mid-position, and showing the crane with its boom and live mast.

FIG. 3 is a side elevation view of the mobile lift crane of FIG. 1 with the counterweight in a rearward position.

FIG. 4 is a partial perspective view of the crane of FIG. 1 with the counterweight in a rearward position.

FIG. 5 is a partial rear elevation view of the crane of FIG. 1, taken along line 5-5 of FIG. 4.

FIG. 6 is a partial side elevation view of the crane of FIG. 1, taken along line 6-6 of FIG. 4.

FIG. 7 is a side elevation view of a counterweight support beam that may be attached to the counterweight tray used on the crane of FIG. 1 to produce a second embodiment of a mobile lift crane of the present invention.

FIG. 8 is a side elevation view of the counterweight support beam of FIG. 7 attached to the counterweight tray.

FIG. 9 is an enlarged side elevation view of the attached portion of the counterweight support beam of FIG. 7 attached to the counterweight tray.

FIG. 10 is a side elevation view of the counterweight support beam of FIG. 7 attached to the counterweight tray with individual counterweights stacked on the counterweight support beam.

FIG. 11 is a rear elevation view of the counterweight support beam and counterweights of FIG. 10.

FIG. 12 is a top plan view of the counterweight support beam of FIG. 10.

FIG. 13 is a side elevation view of the basic crane of FIG. 1 with the counterweight support beam and counterweights of FIGS. 10-12 attached, as well as a lattice mast and boom, with the counterweight support beam and counterweights both in a far forward position.

FIG. 14 is a side elevation view of the crane of FIG. 13 with the counterweight support beam in a forward position and the counterweight unit in a rearward position.

FIG. 15 is a side elevation view of the crane of FIG. 13 with the counterweight support beam in an extended position and the counterweight unit in a rearward position.

FIG. 16 is a side elevation view of a third embodiment of the invention, utilizing the crane of FIG. 13 with the counterweight support beam in an extended position, the counterweight unit in a rearward position and an additional auxiliary counterweight attached to the rear of the counterweight support beam.

FIG. 16A is an enlarged, partially exploded view of the auxiliary counterweight attached to the crane of FIG. 16.

FIG. 17 is a side elevation view of a fourth embodiment of a lift crane of the present invention, with an alternative counterweight support beam attached, with the counterweight support beam and the counterweight unit in a forward position.

FIG. 18 is a side elevation view of the crane of FIG. 17 with the counterweight support beam and the counterweight unit in a rearward position.

FIG. 19 is a side elevation view of the counterweight support beam and counterweight unit used on the crane of FIG. 17.

FIG. 20 is a top plan view of the crane of FIG. 17 with the boom and masts removed for sake of clarity.

FIG. 21 is a side elevation view of the crane of FIG. 17 with the boom and masts removed for sake of clarity.

FIG. 22 is a rear elevation view of the crane of FIG. 17 with the boom and masts removed for sake of clarity.

FIG. 23 is a perspective view of a fifth embodiment of a mobile lift crane with a variable position counterweight, shown with the counterweight in a rearward position.

FIG. 24 is a perspective view of a sixth embodiment of a mobile lift crane, using the main crane components of the crane of FIG. 23 but without the fixed mast, shown with the counterweight in a forward position.

FIG. 25 is a perspective view of the mobile lift crane of FIG. 24 with the counterweight in a rearward position.

FIG. 26 is a partial rear perspective view of the crane of FIG. 24 with the stacks of individual counterweights removed for sake of clarity, but with the counterweight tray in a rearward position.

FIG. 27 is a side elevation view of the crane of FIG. 24 with the counterweight in a forward position.

FIG. 28 is a side elevation view of the crane of FIG. 24 with the counterweight in a rearward position.

FIG. 29 is an enlarged perspective view of the counterweight support frame and stacks of counterweight of the crane of FIG. 24 disconnected from the crane.

FIG. 30 is a top plan view of the counterweight support frame of FIG. 29 and the counterweight unit movement device associated therewith.

FIG. 31 is a side elevation view of the counterweight support frame of FIG. 30.

FIG. 32 is a cross-sectional view taken along line 32-32 of FIG. 31.

FIG. 33 is a cross-sectional view taken along line 33-33 of FIG. 31.

FIG. 34 is a cross-sectional view taken along line 34-34 of FIG. 31.

FIG. 35 is a rear perspective view of the counterweight unit movement device used on the crane of FIG. 24 and shown in FIG. 30.

FIG. 36 is a front perspective view of the counterweight unit movement device shown in FIG. 35.

FIG. 37 is a rear elevation view of the counterweight unit movement device shown in FIG. 35.

FIG. 38 is a rear perspective view of the crane of FIG. 23 with the counterweight support beam and the counterweight unit in a rearward position.

FIG. 39 is a side elevation view of the crane of FIG. 23 with the counterweight support beam and the counterweight unit in a forward, retracted position.

FIG. 40 is a side elevation view of the crane of FIG. 23 with the counterweight support beam in a forward, retracted position and the counterweight unit in a rearward position on the counterweight support beam.

FIG. 41 is a side elevation view of the crane of FIG. 23 with the counterweight support beam and the counterweight unit in a fully extended, rearward position.

FIG. 42 is a front perspective view of the counterweight support beam used on the crane of FIG. 23 with the frame of the counterweight support beam in a retracted position, and also shows the counterweight unit movement device and counterweight tray, with the individual counterweights removed for sake of clarity.

FIG. 43 is front perspective view of the counterweight support beam of FIG. 42 with the frame of the counterweight support beam in an extended position.

FIG. 44 is an exploded view of the telescopic frame of the counterweight support beam of FIG. 42.

FIG. 45 is front perspective view of the counterweight support beam of FIG. 42 in a retracted position, with the top plates of the telescopic frame members removed for sake of clarity.

FIG. 46 is front perspective view of the counterweight support beam of FIG. 42 in an extended position, with the top plates of the telescopic frame members removed for sake of clarity.

FIG. 47 is front perspective view of portions of the counterweight support beam of FIG. 42 in a retracted position, also showing the counterweight unit movement device.

FIG. 48 is front perspective view of portions of the counterweight support beam and counterweight unit movement device shown in FIG. 47 in an extended position.

FIG. 49 is side elevation view of the counterweight support beam of FIG. 42 in an extended position, with the counterweight unit movement device and counterweight tray removed for sake of clarity.

FIG. 50 is top plan view of the counterweight support beam of FIG. 49 in an extended position, with top plates of the frame members removed for sake of clarity.

FIG. 51 is side elevation view of the counterweight support beam of FIG. 42 in an extended position, with the counterweight unit movement device in a rearward position, but without the counterweight tray.

FIG. 52 is top plan view of the counterweight support beam of FIG. 51 in an extended position.

FIG. 53 is a rear elevation view taken along line 53-53 of FIG. 51.

FIG. 54 is a cross-sectional view taken along line 54-54 of FIG. 51.

FIG. 55 is a cross-sectional view taken along line 55-55 of FIG. 51.

FIG. 56 is a cross-sectional view taken along line 56-56 of FIG. 51.

FIG. 57 is a cross-sectional view taken along line 57-57 of FIG. 51.

FIG. 58 is a cross-sectional view taken along line 58-58 of FIG. 51.

FIG. 59 is a cross-sectional view taken along line 59-59 of FIG. 51.

FIG. 60 is a cross-sectional view taken along line 60-60 of FIG. 51.

FIG. 61 is a side elevation view of the crane of FIG. 23 like FIG. 39, but showing alternate connection lugs rotating bed and the counterweight support beam.

FIG. 62 is a rear perspective view of the crane of FIG. 61 showing the details of the alternate connection lugs, with the left side portion on the left lug of the counterweight support beam removed for sake of clarity.

DETAILED DESCRIPTION OF THE DRAWINGS AND THE PRESENTLY PREFERRED EMBODIMENTS

The present invention will now be further described. In the following passages, different aspects of the invention are defined in more detail. Each aspect so defined may be combined with any other aspect or aspects unless clearly indicated to the contrary. In particular, any feature indicated as being preferred or advantageous may be combined with any other feature or features indicated as being preferred or advantageous.

Several terms used in the specification and claims have a meaning defined as follows.

The term "rotating bed" refers to the upperworks of the crane (the part that rotates with respect to the carbody), but does not include the boom or any lattice mast structure. The rotating bed may be made up of multiple parts. For example, for purposes of the present invention, the adapter plate

disclosed in U.S. Pat. No. 5,176,267 would be considered to be part of the rotating bed of the crane on which it is used. Also, if a crane is taken apart for transportation between job sites, the rotating bed, as that term is used herein, may be transported in more than one piece. Further, when a component, such as a counterweight support frame shown in FIG. 24, is attached to the remainder of the rotating bed in a manner that it stays fixed to the remainder of the rotating bed until completely removed, it can be considered to be part of the rotating bed.

The term "mast" refers to a structure that is attached to the rotating bed and is part of the boom hoist system. The mast is used to create an elevated point above the other parts of the rotating bed through which a line of action is established so that the boom hoist system is not trying to pull the boom up along a line nearly through the boom hinge pin during a set-up operation. In this regard, a gantry or some other elevated structure on the rotating bed can serve as a mast. The mast may be a fixed mast, a derrick mast or a live mast, depending on the embodiment of the invention. A live mast is one that has fixed length pendants between the mast and the boom during normal crane pick, move and set operations, and the angle of the boom is changed by changing the angle of the mast. A fixed mast is designed to stay at a fixed angle with respect to the rotating bed during normal crane pick, move and set operations. (However, a small degree of movement may occur in a fixed mast if the balance of the counterweight moment and the combined boom and load moment change so that the mast is pulled backward by the counterweight. In that case mast stops are used to hold the mast up, but those mast stops may allow for a small degree of movement.) Of course a mast which is fixed during normal crane operations may be pivotal during crane set-up operations. A derrick mast is one that has adjustable length boom hoist rigging between the mast and the boom, thus allowing the angle of the boom with respect to the plane of rotation of the rotating bed to be changed, but also is connected to the rotating bed in a pivotal fashion, and is connected to the rear of the rotating bed with an adjustable-length connection. A derrick mast may be used as a fixed mast by keeping the angle of the derrick mast with respect to the rotating bed constant during a pick, move and set operation.

The front of the rotating bed is defined as the portion of the rotating bed that is between the axis of rotation of the rotating bed and the position of the load when a load is being lifted. The rear of the rotating bed includes everything opposite the axis of rotation from the front of the rotating bed. The terms "front" and "rear" (or modifications thereof such as "rearward") referring to other parts of the rotating bed, or things connected thereto, such as the mast, are taken from this same context, regardless of the actual position of the rotating bed with respect to the ground engaging members.

The rearmost fixed portion of the rotating bed is defined as the part of the rotating bed that is designed to not move with respect to the rest of the rotating bed during normal crane pick, move and set operations, and that is furthest from the centerline of rotation between the rotating bed and the carbody.

The tail swing of the crane is used to signify the distance from the axis of rotation of the crane to the furthest away portion of the rotating bed (or other component that swings with the rotating bed). The tail swing is dictated by the portion of the crane that swings with the rotating bed but is behind the axis of rotation compared to the boom and which produces the broadest arc when the crane rotates about the

rotatable connection between the carbody and the rotating bed. If a back corner of the rotating bed is 25 feet from the axis of rotation, the crane is said to have a tail swing of 2.5 feet, and when the crane is set up to be used, no obstructions can be present within that tail swing distance. In many cranes the fixed counterweight is mounted on the rear of the rotating bed, and constitutes the furthest away portion of the rotating bed, and thus dictates the tail swing of the crane. On cranes with a moveable counterweight, often the counterweight moving backwards to compensate for a greater load will increase the tail swing of the crane. It must be remembered that the width of a part on the rear of a crane may affect the tail swing, because the distance to the axis of rotation of that part is a function of how far back on the rotating bed the part is, and how far to the side it is from the centerline of the crane.

The position of the counterweight unit is defined as the center of gravity of the combination of all counterweight elements and any holding tray to which the counterweights are attached, or otherwise move in conjunction with. All counterweights on a crane that are tied together so as to always move simultaneously are treated as a single counterweight unit for purposes of determining the center of gravity.

The term "upperworks counterweight" means the counterweight that is attached to and rotates with the rotating bed during crane pick, move and set operations. These may be stacks of individual counterweights. Often the upperworks counterweight is removable from the rest of the rotating bed. The term "upperworks counterweight unit" includes the upperworks counterweight and any tray that holds the individual counterweights. If the counterweight is moveable, then "upperworks counterweight unit" includes elements that necessarily move with the counterweight. For example, in the embodiment shown in FIGS. 38-60, the upperworks counterweight unit includes the tray 533, the individual counterweights stacked on the tray, and the trolley 570, since it moves with the counterweight. The outer beam member 532 is not part of the upperworks counterweight unit because the counterweight unit can move independently of outer beam member 532.

The term "total weight of the crane" means the weight of the crane without a load on the hook, but includes the weight of all the components of the crane as it is set up for a particular lift. Thus the total weight of a mobile lift crane includes the weight of any counterweights that are included with the crane for the lift, as well as the normal crane components, such as the crawlers, carbody, any carbody counterweight, the rotating bed, any mast that is included, all of the rigging and hoist drums, and all other accessories on the crane that travel with the crane when the assembled crane moves over the ground.

The term "total weight of the crane equipped with a basic boom length" means the total weight of the crane when it is configured with a basic boom, which is defined below.

The top of the mast is defined as the furthest back position on the mast from which any line or tension member supported from the mast is suspended.

The combined boom and load moment is defined as the moment about the center of rotation of the rotating bed created by the dead weight of the boom, including the load hoist line and hook block, and any load suspended from the boom. If no load is on the load hoist line, then the combined boom and load moment will be the moment created by the dead weight of the boom. The moment takes into consideration the length of the boom, the boom angle and the load radius.

The moveable ground engaging members are defined as members that are designed to remain engaged with the ground while the crane moves over the ground, such as tires or crawlers, but does not include ground engaging members that are designed to be stationary with respect to the ground, or be lifted from contact with the ground when they are moved, such as a ring on a ring supported crane and outriggers commonly found on truck mounted cranes.

The term “move” when referring to a crane operation includes movement of the crane with respect to the ground. This can be either a travel operation, where the crane traverses a distance over the ground on its moveable ground engaging members; a swing operation, in which the rotating bed rotates with respect to the ground; or combinations of travel and swing operations.

The term “center of gravity of the boom” refers to the point about which the boom could be balanced. In calculating the center of gravity, all of the components attached to the boom structure that have to be lifted when the boom is initially raised, such as any sheaves mounted in the boom top for the load hoist line, must be taken into account.

Since booms may have various cross section shapes, but are designed with a centerline about which compressive loads are preferably distributed, the term “boom angle,” means the angle of the centerline of the boom compared to horizontal.

The term “basic boom length” is the length of the shortest boom configuration that a crane manufacturer has specified as acceptable for use with a given model of crane.

The term “horizontal boom angle” refers to the boom being at a position where the boom is at or very close to a right angle with the direction of gravity. Likewise, the term “parallel to the ground” has the same meaning. Both of these terms have a meaning that takes into account small variations that occur in normal crane set-up and usage, but which a person of ordinary skill in the art would still think of as being horizontal. For example, when a boom is originally assembled on the ground before being lifted into an operational position, it is considered to be at a horizontal boom angle even if the ground is not exactly level or if parts of the boom are on blocks. The boom can be slightly above or slightly below an exact horizontal position depending on the blocking used, and still be considered to be at a horizontal boom angle and parallel to the ground.

Stability is mostly concerned with the crane as a whole being able to stay upright during crane lifting operations. Rear tipping stability for lift cranes that have an upperworks that rotates about a lowerworks may be expressed as a ratio of a) the distance between the center of gravity of the entire crane and the axis of rotation to b) the distance between the rear tipping fulcrum (typically the center of the last roller in the frame of a crawler for a crawler crane) and the axis of rotation. Thus if the distance between the center of gravity of the entire crane and the axis of rotation were 3.5 meters, and the distance between the rear tipping fulcrum from the axis of rotation were 5 meters, the stability would be 0.7. The lower the value of this ratio, the more stable the crane is. Of course the center of gravity of the crane is a function of the relative magnitudes and relative positions of the centers of gravity of the different crane components. Thus, the length and weight of the boom and the boom angle can greatly influence the location of the center of gravity of the entire crane, and thus the crane’s stability, as can the weight and position of the counterweight unit. Backward tipping stability is of the greatest concern at high boom angles with no load on the hook. Raising the boom will decrease the rear tipping stability of a crane because the center of gravity of

the boom is brought closer to the axis of rotation, and thus the center of gravity of the entire crane may be moved further behind the axis of rotation. The stability number is thus higher, as the numerator of the ratio increases, signifying that the crane is less stable.

When determining the center of gravity of the entire crane, it is often useful to determine contributions to that center of gravity by considering the weight of each individual crane component and the distance that the center of gravity of that component is from a point of reference, and then use a summation of the moments generated about that reference point by each crane component. The individual values in the summation are determined by multiplying the weight of the component by the distance between the center of gravity of that component and the reference point. For rear tipping stability calculations, it is common to use the axis of rotation as the reference point when making the summation to determine the center of gravity of the entire crane.

When considering the moment generated by the boom, it is common to separate the total boom weight, located at the center of gravity of the entire boom, into two separate weights, one at the boom butt called the “boom butt weight”, and one at the boom top called the “boom top weight”. The total weight of the boom will be equal to the boom top weight plus the boom butt weight. Those weights are determined by calculating what force would be generated if the boom were simply supported at each end, with the assumptions that the load hoist line reaches to but is not reeved through the boom top, and that the boom straps are connected. Thus, if one scale were placed under the boom butt at the point the boom connects to the rotating bed (the boom hinge point) and another scale were placed under the boom top at the point the boom top sheaves are connected, the weight on the two scales combined would of course be the weight of the boom, and the individual scale weights would be the boom butt weight and the boom top weight, respectively.

Several embodiments of the invention are shown in the attached drawings. A first basic crane model with a first counterweight set-up configuration is shown in FIGS. 1-6. That same basic crane model can be set up with a second counterweight set-up configuration, as shown in FIGS. 13-15. A further modification of the first basic crane with a third counterweight set-up configuration is shown in FIG. 16. A second basic crane model with a first counterweight set-up configuration is shown in FIGS. 24-28. That same second basic crane model can be set up with a second counterweight set-up configuration, as shown in FIGS. 23 and 38-41. FIGS. 17-22 show a third basic crane model set up in a counterweight set-up configuration similar to the second counterweight set-up configurations of the other basic crane models.

In the first embodiment, shown in FIGS. 1-6, the mobile lift crane 10 includes lowerworks, also referred to as a carbody 12 (best seen in FIGS. 4 and 5), ground engaging members elevating the carbody off the ground; and a rotating bed 20 rotatably connected to the carbody about an axis of rotation. The moveable ground engaging members on the crane 10 are in the form of two crawlers 14, only one of which can be seen from the side view of FIG. 1. (FIG. 1 is simplified for sake of clarity, and does not show the boom and mast.) The other crawler 14 can be seen in the perspective view of FIG. 4 and in the rear view of FIG. 5. In the crane 10, the moveable ground engaging members could be multiple sets of crawlers, such as two crawlers on each side, or other moveable ground engaging members, such as tires.

13

In the crane 10 the crawlers provide front and rear tipping fulcrums for the crane. FIG. 1 shows the rear tipping fulcrum 16 and the front tipping fulcrum 17 of crane 10.

The rotating bed 20 is mounted to the carbody 12 with a slewing ring, such that the rotating bed 20 can swing about an axis with respect to the ground engaging members 14. The rotating bed supports a boom 22 pivotally mounted in a fixed position on a front portion of the rotating bed; a live mast 28 mounted at its first end on the rotating bed; and a moveable counterweight unit 35 having counterweights 34 on a support member in the form of a counterweight tray 33. The counterweights in this embodiment are provided in two stacks of individual counterweight members 34 on the counterweight tray 33 as shown in FIGS. 4 and 5. The rotating bed has a rearmost fixed portion, which will be discussed in detail below. In the crane 10, since the counterweight is moveable, it does not constitute the rearmost fixed portion of the rotating bed, even though when the counterweight is moved to a rearward position the outside corner of the counterweights 34 will be the furthest from the rotational centerline and thus define the tail swing of the crane. However, when the counterweight unit 35 is pulled forward, as in FIG. 1, the rearmost fixed portion of the rotating bed will define the tail swing of the crane.

A boom hoist system on crane 10 allows the angle of the boom 22 relative to the plane of rotation of the rotating bed 20 to be changed in the crane 10, the boom hoist system includes rigging connected between the rotating bed 20, the mast 28 and the boom 22. The boom hoist system includes a boom hoist drum and boom hoist line reeved between a sheave set on the mast and a sheave set on the rotating bed. The mast 28 is pivotally connected to the rotating bed and the boom hoist rigging between the mast and the boom comprises only fixed length members in the form of two sets of pendants 25 (only one of which can be seen in the side view) connected between the mast 28 and the top of the boom 22. In addition the boom hoist rigging includes multiple parts of boom hoist line 27 between sheaves 23 on the rotating bed and sheaves on the second end of mast 28. A boom hoist drum 21 on the rotating bed can thus be used to take up or pay out boom hoist line 27, changing the angle of the live mast 28 with respect to the rotating bed, which in turn then changes the angle of the boom 22 with respect to the rotating bed 20. (Sheaves 23 and drum 21 are not shown on FIGS. 4-6 for sake of clarity.) Alternatively, the mast 28 could be used as a fixed mast during normal crane operation, with boom hoist line running between an equalizer and the top of the mast to change the angle between the mast and the boom.

A load hoist line 24 for handling a load extends from the boom 22, supporting a hook 26. The rotating bed 20 may also include other elements commonly found on it mobile lift crane, such as an operator's cab and whip line drum 29. The load hoist drum 13 for the hoist line 24 is preferably mounted on the boom butt, as shown in FIG. 2. If desired, an additional hoist drum 19 can be mounted at the base of boom 22, as shown in FIGS. 2 and 3. The boom 22 may comprise a luffing jib pivotally mounted to the top of the main boom, or other boom configurations.

The counterweight unit 35 is moveable with respect to the rest of the rotating bed 20. In the crane 10, the rotating bed 20 includes a counterweight support frame 32, preferably in the form of a welded plate structure including a pair of spaced-apart side members best seen in FIGS. 4-6. The counterweight support frame 32 supports the moveable counterweight unit 35 in a moveable relationship with respect to the counterweight support frame 32. The coun-

14

terweight support frame 32 comprises a sloped surface provided by flanges 39 that the counterweight unit 35 moves on, that surface sloping upwardly compared to the plane of rotation between the rotating bed and the carbody as the counterweight support frame extends rearwardly. The counterweight tray 33 includes rollers 37 which rest on the flanges 39 welded to the plate structure of the support frame. The rollers 37 are placed on the top of the counterweight tray 33 so that the tray 33 is suspended beneath the counterweight support frame 32. In the crane 10, the counterweight support frame constitutes the rearmost fixed portion of the rotating bed. Further, the counterweight support frame 32 is supported on the rotating bed 20 in a fashion such that the moment generated by the counterweight unit 35 acts on the rotating bed 20 predominantly, and in this case only, through the counterweight support frame.

A counterweight movement system is connected between the rotating bed 20 and the counterweight unit 35 so as to be able to move the counterweight unit 35 toward and away from the boom. The counterweight unit 35 is moveable between a position where the counterweight unit is in front of the rearmost fixed portion of the rotating bed, such that the tail swing of the crane is dictated by the rearmost fixed portion of the rotating bed (as seen in FIGS. 1 and 2), and a position where the counterweight unit dictates the tail swing of the crane (as seen in FIGS. 3, 4 and 6). Preferably the counterweight unit 35 can be moved to a point so that the center of gravity of the counterweight unit is near to, and preferably even in front of, the rear tipping fulcrum 16 of the crane, as seen in FIG. 1.

The counterweight movement system in the crane 10 comprises a counterweight unit movement device made up of a drive motor 40 and a drum on the rear of the counterweight support frame 32. Preferably the counterweight unit movement device has two spaced apart identical assemblies, and thus the drive motor 40 drives two drums 42, best seen in FIG. 4. Each assembly of the counterweight unit movement device further includes a flexible tension member that passes around a driven pulley and idler pulley 41 (best seen in FIG. 1). The driven pulleys are provided by drums 42. The flexible tension member may be a wire rope 44 as shown, or a chain. Of course if a chain is used, the driven pulley will be a chain drive. Both ends of each flexible tension member are connect to the counterweight tray 33 as seen in FIG. 6, so that the counterweight unit 35 can be pulled both toward and away from the boom. Preferably this is accomplished by having an eye 43 on both ends of the wire rope 44 and holes in a connector 45 on the counterweight tray 33, with pins through the eyes and the connector 45. Thus, in the crane 10, the counterweight unit movement device is connected between the counterweight support frame 32 and the counterweight unit 35.

While FIG. 1 shows the counterweight unit 35 in its most forward position, FIG. 2 shows the counterweight unit 35 in a mid-position, and FIGS. 3-6 show the counterweight unit 35 in its most rearward position, such as when a large load is suspended from the hook 26, or the boom 22 is pivoted forward to extend the load further from the rotating bed. In each of these positions, the crane is configured such that during crane operation, when the counterweight is moved to compensate for changes in the combined boom and load moment, the weight of the counterweight unit 35 is transferred to the rotating bed only through the counterweight support frame 32. The phrase "only through the counterweight support frame" is meant to differentiate prior art cranes where a tension member between the top of a mast and the counterweight provides at least some of the support

15

for the counterweight, such as the arrangement disclosed in U.S. Pat. No. 4,953,722, which has a backhitch pendant connecting the rear of the support beam to mast, and thus supports the beam from both ends. In the crane **10**, all of the counterbalance force provided by the counterweight unit **35** is transmitted through the counterweight support frame **32** to the rest of the rotating bed. Meanwhile, the boom hoist rigging transfers forward tipping forces from the boom and any load on the hook to the rear of the rotating bed.

With the preferred embodiment of the present invention, the moveable counterweight is never supported by the ground during normal operations. The crane can performing a pick, move and set operation with a load wherein the moveable counterweight is moved toward and away from the front portion of the rotating bed by operating hydraulic motor **40** and drums **42** to move the counterweight during the crane operation to help counterbalance the load, but the counterweight is never supported by the ground other than indirectly by the moveable ground engaging members on the carbody. Further, the moveable counterweight unit **35** is the only functional counterweight on the crane. The carbody is not provided with any separate functional counterweight. The fact that the counterweight unit can be moved very near to the centerline of rotation of the crane means that the counterweight does not produce a large backward tipping moment in that configuration, which would otherwise require the carbody to carry additional counterweight. The phrase “not provided with any separate functional counterweight” is meant to differentiate prior art cranes where the carbody is specifically designed to include significant amounts of counterweight used to prevent backward tipping of the crane. For example, on a standard model 16000 crane from, the Manitowoc Crane Company, the carbody is provided with 120,000 pounds of counterweight, and the rotating bed is provided with 332,000 pounds of upperworks counterweight. With cranes of the present invention, all 452,000 pounds of that counterweight could be used in the moveable counterweight unit, and no functional counterweight added to the carbody.

The counterweight positioning may be manually controlled, or the crane **10** can further comprise a sensor (not shown) that senses a condition that is related to a need to move the counterweight. In its simplest form, the counterweight may be moved in response to a change of boom angle. In a more sophisticated manner, the combined boom and load moment can be used to control movement of the counterweight, so that either a change in boom angle, or picking up a load, will result in movement of the counterweight. If desired, this can be accomplished automatically if a computer processor is coupled with the sensor. In that case, a computer processor controlling the counterweight movement system, and possibly other operations of the crane, receives signals from the sensor indicating the condition (such as the boom angle), or some other function indicative of the condition (such as tension in the boom hoist rigging, which is indicative of the combined boom and load moment, or the moment of the boom and load about the hinge pins of the boom) and controls the position of the counterweight unit. The position of the counterweight may be detected by keeping track of the revolutions of drums **42**, or using a cable and reel arrangement (not shown). The crane using such a system will preferably comprise a computer readable storage medium comprising programming code embodied therein operable to be executed by the computer processor to control the position of the counterweight unit.

FIGS. **13-15** show a second embodiment of a crane **110** of the present invention. In addition to the live mast **128**, this

16

embodiment includes a fixed position mast **117**, which has some disadvantages compared to the crane **10** since the fixed mast structure requires additional components to be delivered to a job site, and is sometimes an obstacle requiring clearance when the crane is repositioned. However, the addition of the fixed mast **117** allows the crane **110** to be equipped with other features that increase the lifting capacity of the crane. As with crane **10**, in crane **110** the carbody is not provided with any separate functional counterweight, and the moveable counterweight unit is never supported by the ground during crane pick, move and set operations other than indirectly by moveable ground engaging members on the carbody.

Crane **110** is made with the same basic crane structure of crane **10**, but has an additional counterweight support beam **160** added to it, as well as the fixed mast **117**. Instead of a fixed mast, a derrick mast could also be used. The counterweight support beam **160** is shown in FIGS. **7-12**. The counterweight support beam **160** is moveably connected to the rotating bed **120**. The crane **110** utilizes the same structure that moved the counterweight unit **35** on crane **10** as a counterweight support beam movement device, as explained below. Thus, in this embodiment, the counterweight movement system includes a counterweight unit movement device and a counterweight support beam movement device. This counterweight support beam movement device is connected between the counterweight support beam **160** and the rotating bed **120** such that the counterweight support beam can be moved with respect to the length of the rotating bed away from the rotational connection of the rotating bed and the carbody, and extended rearwardly of the rearmost fixed portion of the rotating bed. As will be explained more fully below, the movement of the counterweight support beam **160** is generally horizontal and in a direction in line with the length of the counterweight support beam. The crane **110** further includes a tension member **131** connected between the fixed mast **117** and the counterweight support beam **160**. The counterweight unit **135** is supported on the counterweight support beam **160** in a moveable relationship with respect to the counterweight support beam. The counterweight unit movement device is connected between the counterweight support beam **160** and the counterweight unit **135** so as to be able to move the counterweight unit toward and away from the boom **122**. The counterweight unit **135** may be moved to and held at a position in front of the top of the fixed mast **117** and moved to and held at a position rearward of the top of the fixed mast **117**.

Crane **110** includes a live mast **128** just like live mast **28** on crane **10**. However, after being used to erect the fixed mast **117**, live mast **128** is thereafter disabled from changing position. To change the boom angle on crane **110**, boom hoist line **115** travels up from boom hoist drum **118** mounted at the base of mast **117** and is reeved with multiple parts of line between an equalizer **129** and sheaves on the top of fixed mast **117**. The equalizer **129** is connected to the boom **122** by fixed length pendants **126**. Fixed length pendants **125** connect the top of fixed mast **117** to the top of mast **128**. The rigging **127** connects the top of mast **128** to the rotating bed **120** through the sheave set **123** and drum **121**, just as with boom hoist rigging **27**, sheave **23** and drum **21** on crane **10**. Although they are not shown, crane **110** also includes a load hoist line and hook block, just like those used in crane **10**.

The counterweight support beam **160** is preferably in a U shape, made from two spaced apart side members **162**, connected together in the rear by a cross member **164**, best seen in FIG. **12**. The front ends of the two side members **162**

17

connect to a counterweight tray **133**, which is moveably mounted on a counterweight support frame **132** on rotating bed **120** using drive motor and drums on the rear of the rotating bed. This is identical to the way counterweight tray **33** is moveably mounted to the rotating bed **20** on crane **10**. The counterweight support beam **160** is further equipped with a counterweight unit movement device connected between the counterweight support beam **160** and the counterweight unit **135**. The counterweight unit **135** can thus move with the counterweight support beam **160**, and move relative to the counterweight support beam **160**.

The tension member **131** is preferably in the form of two sets of connected flat straps (only one set of which can be seen in the side views) attached adjacent the top of the fixed mast **117** and supports the rear of counterweight support beam **160** in a suspended mode. Since the tension member has a fixed length, when the counterweight support beam **160** is moved rearwardly, the rear of the counterweight support beam will move in an arc, with the center of arc being the point where tension member **131** connects to the top of fixed mast **117**. Thus the rear of the counterweight support beam will rise slightly as it moves rearwardly. In order to keep the counterweight support beam **160** as nearly horizontal as possible, the surface on the counterweight support frame **132** on the rotating bed **120** on which the counterweight tray **133** moves rearwardly comprises a sloped surface (flanges **139**, best seen in FIG. **11**) that slopes upwardly compared to the plane of rotation between the rotating bed and the carbody as the counterweight support beam is moved rearwardly, just as flanges **39** provided the sloped surface on crane **10**. The path could be machined to match the arc shape traveled by the rear of the counterweight support beam but, more practically, a simple straight sloped path is used that provides the same raise in height that the rear of the counterweight support beam **160** will experience as the counterweight support beam **160** is moved to its full rearward position. The movement of the counterweight support beam **160** is thus generally horizontal and in a direction in line with the length of the counterweight support beam. As can best be seen in FIGS. **7** and **10**, rollers **137** are mounted on the counterweight tray **133** such that the rear rollers **137** are at a higher elevation than the front rollers **137** (FIG. **7**). In this manner the counterweight tray **133** will itself remain horizontal while the rollers **137** ride on the sloped surface. Support feet **182** are included as a safety feature and can provide support to the counterweight unit in the event of a sudden release of the load. However, the support feet are sized so that when the counterweight support beam **160** is in its most forward positioned (FIG. **13**), and thus support feet **182** are at their closest point to the ground in the arc created by pivoting the tension member **131** about the top of the mast **117**, the support feet **182** will still be an adequate distance off the ground (such as 15 inches) so that during normal crane operation, the support feet never contact the ground during pick, move and set operations.

The same structure that moved the counterweight tray **33** in crane **10** is used to move the counterweight tray **133** in crane **110**. However, since the counterweight support beam **160** is now connected to the counterweight tray, the counterweight support beam **160** now moves with the counterweight tray **133**. The counterweight support beam **160** can thus be moved to and secured at infinitely variable positions with respect to the rotating bed, meaning that it can be moved a small amount, a large amount (up to the maximum movement of the counterweight tray **133** on the counterweight support frame **132** on the rotating bed), or any

18

position there between. This is different than other extendable counterweight support surfaces, such as counterweight support beam in U.S. Pat. No. 4,953,722, which can be extended and secured at only two different operational positions.

FIG. **9** shows the connection of the counterweight support beam **160** to the counterweight tray **133**. The individual counterweights **134** are not placed on the counterweight tray in this embodiment. Lugs **179** welded to the side members **162** connect to connectors **145** on the counterweight tray **133**. Just as in crane **10**, wire rope **144** is used to move the counterweight tray **133**, and an eye on both ends of wire rope **144** and holes in connector **145** on the counterweight tray **133** are pinned together with pins through the eyes and the connector **145**. At the same place, a pin holds each the lug **179** to a connector **145**. When the motor turns the drums on the end of the counterweight support frame **132** on the rotating bed **120**, the wire rope **144** is moved back and forth, just as wire rope **44** moves on crane **10**. The wire rope **144** pulls the connector **145** on the counterweight tray **133**. At the same time, the counterweight support beam **160** is moved by the connection between lugs **179** and connector **145**.

The sections of counterweight **134** are stacked on the counterweight support beam **160** in a moveable manner, such as on sliding wear pads (not shown). When they are in a far forward position, the counterweight sections are directly above the counterweight tray, to which the counterweight support beam **160** is attached. In this position, just like the counterweight **35**, counterweight unit **135** is moveable to a position in front of the rearmost fixed portion of the rotating bed. In addition, since the counterweight beam **160** can move rearwardly, and the counterweight unit **135** can move rearwardly on the counterweight support beam **160**, the counterweight unit **135** may be moved to and held at a first position in front of the top of the fixed mast, and moved to and held at a second position rearward of the top of the fixed mast **117**.

In this embodiment, the counterweight unit comprises two stacks of counterweights that are moved simultaneously. The stacks each contain the same counterweights **134** that are identical to the counterweights **34** used on crane **10**, plus some additional counterweights **136** (FIGS. **10** and **11**). The stacks each rest on a counterweight base plate **163**, which in turn includes slider pads (not shown) that allow the counterweight base plates to move on the surface of the side members **162**. Rollers could be used instead of slider pads. Pairs of flexible tension members **173**, each of which may be a chain as shown, or a wire rope, passes around driven pulleys in the form of chain drives **176** and idler pulleys **172** (best seen in FIGS. **7** and **12**). The chain drives **176** are mounted on shafts **178** which are turned by a gear box and motor (not shown). The counterweight base plates **163** each attach to these flexible tension members **173** through a connector **189** so that the stacks of counterweight can be pulled both toward and away from the front of the counterweight support beam, and hence toward and away from the boom **122**. (The counterweight base plates **163** are not shown in FIG. **12** for sake of clarity).

The crane **110** thus includes a moveable counterweight support beam **160** and a moveable counterweight unit **135** supported on the moveable counterweight beam that can be moved independently on the counterweight support beam. The angle of the boom can be changed, or the crane can performing a pick, move and set operation with a load, wherein the moveable counterweight unit is moved toward and away from the front portion of the rotating bed during

19

the boom angle change or pick, move and set operation to help counterbalance the combined boom and load moment. At first, the counterweight unit **135** will move to the rear of the crane while the counterweight support beam remains in its forward position. If further counterbalancing is needed, the counterweight unit **135** can stay on the counterweight support beam **160** during the change in the combined boom and load moment, and the counterweight support beam and counterweight unit can move together to counterbalance the crane as the boom angle is lowered or a load is picked up. As with crane **10**, in the preferred embodiment, the counterweight unit **135** can move forward of the rearmost fixed portion of the rotating bed **120**.

Since the basic crane **10** can be used to make the crane **110**, one aspect of the invention is a crane that is configured to be set up with two different counterweight set-up configuration options. The first counterweight set-up configuration option (crane **10**) has a first counterweight movement system that can move a first counterweight unit **35** between a first position (FIG. **1**) and a second position (FIG. **3**). For the crane **10**, the counterweight set-up configuration is a counterweight unit **35** directly supported on the counterweight support frame **32** and the counterweight unit movement device is connected so as to move the counterweight unit with respect to the counterweight support frame. The first position is a position in which the first counterweight unit is as near as possible to the axis of rotation for the first counterweight set-up configuration option. This constitutes a first distance from the axis of rotation. The second position is a position in which the first counterweight unit is as far as possible from the axis of rotation for the first counterweight set-up configuration option. This distance constitutes a second distance from the axis of rotation.

The second counterweight set-up configuration option (crane **110**) has a second counterweight movement system that can move a second counterweight unit **135** between a third position (FIG. **13**) and a fourth position (FIG. **15**). For the crane **110**, the counterweight set-up configuration includes a counterweight support beam **160** moveably connected to the counterweight support frame **132** and a counterweight unit **135** supported on the counterweight support beam, with the counterweight support beam movement device connected so as to move the counterweight support beam with respect to the counterweight support frame. The third position is a position in which the second counterweight unit is as near as possible to the axis of rotation for the second counterweight set-up configuration option. This constitutes a third distance from the axis of rotation. The fourth position is a position in which the second counterweight unit is as far as possible from the axis of rotation in the second counterweight set-up configuration option, which constitutes a fourth distance from the axis of rotation.

As evident from the drawings, for the cranes **10** and **110**, the fourth distance is greater than the second distance, and the difference between the third and fourth distances is greater than the difference between the first and second distances. The difference between the third and fourth distances is preferably at least 1.5 times as large as the difference between the first and second distances, more preferably at least 2.0 times as large as the difference between the first and second distances, and even more preferably at least 2.5 times as large as the difference between the first and second distances. With preferred embodiments of the invention, the difference between the third and fourth distances is at least 3 times as large as the difference between the first and second distances.

20

In the preferred embodiment, the crane **10** includes a counterweight tray **33** movably supported on the counterweight support frame **32**, and in the first option counterweights **34** are stacked directly on the counterweight tray **33**, and in the second option the counterweight support beam **160** is attached to the counterweight tray **133** and counterweights **134** are stacked on the counterweight support beam **160**. The second counterweight unit will typically have more counterweight boxes included than the first counterweight unit. However, while not shown in the depicted embodiments, the first and second counterweight units could be identically configured.

FIG. **16** shows a third embodiment of a crane, which is just like crane **110** in all but one feature. Thus the reference numbers used on the parts of crane **210** in FIG. **16** are identical to the parts of the crane **110** with the same reference number with an addend of 100. For example, boom **222** on crane **210** is just like boom **122** on crane **110**. Likewise boom hoist line **215**, fixed mast **217**, boom hoist drum **218** rotating bed **220**, drum **221**, sheave set **223**, fixed length pendants **225**, fixed length pendants **226**, mast **228**, equalizer **229**, tension member **231** and counterweight unit **235** are just the same as their respective components in crane **110**. The one difference is that crane **210** includes an additional counterweight unit **237** attached to the rear of the counterweight support beam **260**. The additional counterweight unit **237** is used to further increase the lifting capacity of the basic crane **10**. It moves in and out with the counterweight support beam **260**.

FIG. **16A** shows the details of how the auxiliary counterweight attaches to the counterweight support beam **260**. The auxiliary counterweight **237** includes a counterweight tray **252** which is provided with side panels **254** that include a hook element **256**. The counterweight support beam **260** is provided with extensions **66** on the rear side of cross member **264**, which mate with the side panels **254**. A pin **268** in each extension **266** allows the hook element **256** to connect to the pin **268** from above, with a rotational engagement. Each side panel **254** is provided with a bearing surface **258**, and the cross member **264** is provided with a bearing surfaces **269** that abut the surfaces **258** to limit the rotation when the hook element **256** is engaged with the pin **268**, thus holding the tray **252** in a connected, horizontal position.

FIGS. **17-22** show a fourth embodiment of a crane **310** of the present invention. Like crane **110**, crane **310** includes a carbody **312**, crawlers **314**, rotating bed **320**, boom **322**, boom hoist rigging **325**, a fixed mast **317**, a live mast **328**, a counterweight support beam **360** moveably connected to the rotating bed such that the rear portion of the counterweight support beam **360** can be extended away from the rotational connection of the rotating bed and the carbody, a counterweight unit **335** supported on the counterweight support beam **360** in a moveable relationship with respect to the counterweight support beam, and a tension member **331** connected between the fixed mast and the counterweight support beam **360**. The primary difference between the crane **310** compared to crane **110** is that the counterweight support beam **360** has a telescoping feature, and the front portion of it stays connected to the rotating bed **320** at the same place all of the time. Further, the counterweight movement system simultaneously causes the counterweight unit **335** to move rearwardly with respect to the counterweight support beam **360** as the telescoping rear portion of the counterweight support beam moves rearwardly with respect to the rotating bed **320**. In this fashion a single driving device moves the counterweight support beam with respect to the rotating bed (serving as the counterweight support beam moving device)

and moves the counterweight unit with respect to the counterweight support beam (serving as a counterweight unit movement device).

The counterweight support beam **360** is preferably in a U shape, made from two spaced apart side members **362**, connected together in the rear by a cross member **364**, best seen in FIG. **20**. The front ends of the two side members **362** connect to the rotating bed **320**. Each side member **362** is made from two sections that fit together in a telescoping fashion. FIG. **17** shows the two sections in a retracted position, while FIGS. **18-21** show the two sections in an extended position.

FIG. **19**, which shows the counterweight support beam **360** by itself, with the counterweight unit **335** resting on it, and FIG. **20**, which shows the counterweight support beam **360** connected to the rotating bed **320** of crane **310** but with other portions of crane **310** removed for sake of clarity, shows the counterweight support beam movement device. The counterweight support beam movement device comprises a telescoping cylinder **355** attached between the rotating bed **320** and the counterweight support beam **360**, and a plurality of flexible tension members in the form of wire ropes **373** that pass around pulleys **371** and **372** and which connect to the counterweight unit **335** at connections **376** and to the counterweight support beam **360** at connections **378**. The counterweight unit **335** can be pulled toward the boom as the telescoping cylinder **355** retracts and pulls the rear portion **364** of the counterweight support beam towards the boom. When this happens, the pulleys **372** on the counterweight support beam **360** have to also move forward. Since the wire ropes **373** are connected at both the connections **376** and **378**, in order for the pulleys **372** to move forward, the wire rope has to travel in a clockwise fashion (as seen from the side view in FIG. **21**), which moves the connection **376** forward, which in turn pulls the counterweight unit **335** forward on the counterweight support beam, in addition to the movement of the section of the counterweight support beam itself. On the other hand, when the cylinder **355** is extended, pulleys **371** are pushed backward as the telescoping cylinder extends and pushes the rear portion of the counterweight support beam away from the boom. This causes the wire rope **373** to travel in a counterclockwise direction, pulling connections **376** and counterweight **335** rearwardly.

As can be seen from FIG. **17**, the rotating bed **320** has a rearmost fixed portion, and the counterweight unit **335** is moveable to a position where the counterweight unit **335** is in front of the rearmost fixed portion of the rotating bed. The counterweight unit **335** may be moved to and held at a position in front of the top of the fixed mast (FIG. **17**) and moved to and held at a position rearward of the top of the fixed mast (FIG. **18**) during crane pick, move and set operations. During this movement the moveable counterweight unit **335** is never supported by the ground other than indirectly by the moveable ground engaging members **314** on the carbody **312**. The support feet **382** are included as a safety feature and can provide support to the counterweight unit in the event of a sudden release of the load. However, the support feet are sized so that when the rear **364** of the counterweight support beam **360** is positioned directly below the top of the mast **317** (FIG. **17**), and thus support feet **382** are at their closest point to the ground in the arc created by pivoting the tension member **331** about the top of the mast **317**, the support feet **382** will still be an adequate distance off the ground so that during normal crane operation, the support feet never contact the ground during pick, move and set operations.

FIGS. **23-60** show the details of another embodiment of a crane that can be set up with two different counterweight set-up configurations. FIGS. **24-28** show the crane **410** with a moveable counterweight supported on a counterweight support frame. FIGS. **23** and **38-41** show the same crane with a mast and a moveable counterweight support beam. In this configuration the crane is referred to as crane **510**.

Like crane **10**, crane **410** has a carbody **412**; moveable ground engaging members **414** mounted on the carbody allowing the crane **410** to move over the ground; a rotating bed **420** rotatably connected to the carbody about an axis of rotation; a boom **422** pivotally mounted about a fixed boom hinge point on the front portion of the rotating bed; and a boom hoist system, provided by a live mast **428** and boom hoist rigging **427**, connected between a sheave set on the rotating bed and the boom that allows the angle of the boom relative to the plane of rotation of the rotating bed to be changed. As with crane **10**, the boom hoist system comprises a boom hoist drum and boom hoist line reeved between a sheave set on the mast and a sheave set on the rotating bed. In this embodiment, the rotating bed includes a counterweight support frame **432** that is attached to the remainder of the rotating bed **420** in a detachable fashion, as described in more detail below. The counterweight unit **435** is supported on the counterweight support frame **432** in a moveable relationship with respect to the counterweight support frame **432**. A counterweight unit movement device, also described in more detail below, connects between the rotating bed and the counterweight unit **435** so as to be able to move the counterweight unit **435** toward and away from the boom **422**. In this configuration, as with crane **10**, during crane operation, when the counterweight unit is moved to compensate for changes in the combined boom and load moment, the moment generated by the counterweight unit **435** acts on the rotating bed predominantly, and in this case only, through the counterweight support frame.

The counterweight support frame **432** in this embodiment is located below the remainder of the rotating bed. The counterweight support frame is made of a welded plate structure, best seen in FIGS. **29-34**. It is mounted in a removable fashion to the remainder of the rotating bed. An adapter **450** is used to make an easily removable connection between the rotating bed **420** and the front of the counterweight support frame **432**. The adapter **450** includes holes **452** through ears **454** that fit between lugs **429** on the lower portion of the rotating bed **420** to connect the adapter **450**, and hence the counterweight support frame **432**, to the rotating bed **420**. The adapter **450** is itself secured to the counterweight support frame **432** by pins **456** (best seen in FIG. **34**). The use of pins **456** allows the adapter **450** to be detached from the counterweight support frame **432** so that the counterweight support frame **432** can be reused in the configuration of crane **510**. Front holes **481** serve as a place to pin the counterweight support frame **432** and adapter **450** together. Rear holes **483** and top holes **484** in the counterweight support frame **432** are not used in this embodiment, but are included so that the counterweight support frame **432** can be used in the configuration of crane **510**, as explained below.

At the rear, the counterweight support frame **432** connects to the rotating bed through two short links **462**. The links **462** are each pinned at one end to a lug **464** on the rotating bed and at the other end in between a pair of lugs **466** on the rear of the counterweight support frame **432**. Once the pinned connections are made with the adaptor **450** at the

front and the links 462 at the rear, the counterweight support frame 432 is in reality a detachable portion of the rotating bed of the crane 410.

In crane 410, the counterweight unit movement device is connected between the rotating bed 420 and the counterweight unit 435 by being connected between the counterweight support frame 432, as part of the rotating bed, and the counterweight unit. The counterweight unit 435 comprises a counterweight tray 433 pinned to a moveable trolley 470 (FIGS. 35-37). As with earlier embodiments, the counterweight tray is suspended beneath the counterweight support frame. The tray 433 pins into holes 471 (FIG. 31) on the trolley 470. The holes 471 are bigger on top than on bottom. The bottom dimension is the same as the outside diameter of the pins (not shown) used to connect the tray 433 and the trolley 470. The larger dimension on top allows for easy insertion of the pins.

The trolley 470 rides on four vertical rollers 476 that engage a flange 438 along each side of the counterweight support frame 432. The trolley 470 also includes four horizontal rollers 478 (FIG. 33) that provide sideways positioning of the trolley 470 on the counterweight support frame 432.

The counterweight unit movement device comprises at least one, and in this embodiment, two hydraulic motors and gear boxes 472 each driving a gear 474 connected to the trolley 470. The counterweight support frame 432 includes a set of teeth 436 (FIG. 29) on each side. The gears 474 engage with the teeth 436 on the two sides of the counterweight support frame 432 to move the trolley 470 with respect to the counterweight support frame as the motor and gearbox 472 turns the gear 474. In this way the counterweight unit 435 can move with respect to the counterweight support frame 432 by being mounted on trolley 470.

For ease of fabrication, several individually replaceable sections of steel bar 434 (best seen in FIG. 29) may be bolted onto the rest of the counterweight support frame 432 with socket head cap screws to provide both flange 438 and the teeth 436. In addition, the side surfaces of these steel bars provide the engagement surface for the horizontal rollers 478, as seen in FIG. 33. Preferably the surfaces of these steel bars 434 are hardened to provide better wear resistance with the rollers 476 and 478. The steel bars 434 include shear blocks surfaces 439 (FIGS. 32 and 33) to help carry the load from the rollers 476 on the trolley 470 to the counterweight support frame 432. As seen in FIG. 32, the rollers 476 are preferably mounted in the same vertical plane as the gears 474.

In the preferred embodiment, the crane is configured such that during crane operation, when the counterweight unit is moved to compensate for changes in the combined boom and load moment, the moment generated by the counterweight unit with respect to a front tipping fulcrum of the crane is not transferred to the rotating bed through the mast. Rather, the moment is transferred to the rotating bed by the counterweight support frame, such as through the pinned connections at lugs 429 and 464.

The crane 510 is made from the same components used to make crane 410, with an added fixed mast 517 and a moveable counterweight support beam 560. In addition, the structure used as the live mast 428 in crane 410 is no longer used as a live mast. Instead, boom hoist rigging 519 is provided between the boom top and the top of fixed mast 517 to allow the boom angle to be changed. Fixed length pendants 525 connect the top of fixed mast 517 to the top of mast 528. The rigging 527 and the mast 528 are held in a fixed position during normal operation of crane 520. Also, a

tension member 531 is added between the top of mast 517 and counterweight support beam 560. In the drawings, the components used on the crane 410 that are the same as in crane 510 have the same reference number with an addend of 100; thus boom 422 on crane 410 is boom 522 on crane 510. The counterweight unit 535 is the same as counterweight unit 435.

The counterweight unit 535 on crane 510 may be moved in two ways. First, just like counterweight unit 435, counterweight unit 535 includes a trolley 570 with rollers 576 that ride on flanges on a counterweight support frame. However, in this counterweight set-up configuration, the counterweight support frame is part of the telescoping counterweight support beam 560. Thus, another way to move the counterweight unit 535 is to telescope out the beam 560 while maintaining the location of the counterweight unit 535 on the frame, which in this case is the outer beam member 532. The first type of movement can be seen by comparing FIGS. 39 and 40, and the second type of movement can be seen by comparing FIGS. 40 and 41. Both types of movement can be carried out independently, and need not be carried out to the full extent possible. However, usually the counterweight unit 535 will be moved back on outer beam member 532 until it has moved as far as possible before the beam 560 is extended. As can be seen by comparing FIGS. 39 and 41, with the counterweight movement system of crane 510, the counterweight unit can be moved to a position where it is between the boom hoist sheave set on the rotating bed and the axis of rotation of the carbody, and moved to a position where it is behind the boom hoist sheave set on the rotating bed.

The counterweight support beam 560 is preferably made with three nested, telescoping beam members: an inner beam member 592, a middle beam member 582 and the outer beam member 532, also referred to above as the counterweight support frame. Thus the counterweight support beam movement device comprises a telescoping frame with at least one inner frame member fitting inside an outer frame member. As shown, more preferably the counterweight support beam has an intermediate frame member inside the outer frame member and surrounding the inner frame member. The counterweight support beam comprises the outer frame member of the telescoping frame that is part of the counterweight support beam movement device.

Interestingly, the structure used as the counterweight support frame 432 in the first counterweight set-up configuration option (crane 410) can be used as the outer beam member 532 in the counterweight support beam 560 in the second counterweight set-up configuration option (crane 510). When the counterweight support frame 432 is used as the outer beam member 532, it includes additional internal structure so that it can be connected to the rest of the beam members and move with respect to the rotating bed 520.

Because the trolley 570 is just the same as trolley 470, and the outer beam member 532 has an external configuration like counterweight support frame 432, the way that counterweight unit 535 moves with respect to outer beam member 532, the structure of the trolley 570, motors and gearboxes 572 and gears 574 engaging teeth on sections of steel bar 534 will not be described again in detail. Because of these similarities, in this embodiment the driving gear connected to the trolley engages teeth on the counterweight support beam 560 to move the trolley with respect to the counterweight support beam 560 as the motor turns the gear 574.

The counterweight support beam 560 mounts to the rest of the crane 510 in a fashion similar to how counterweight

support frame **432** connected to the rest of crane **410**. Instead of short links **462**, connecting between lugs **466** and the rear of the rotating bed, the tension members **531** connect from the top of the fixed mast **517** through lugs **566** to the rear of the counterweight support beam **560**. On the front, instead of adaptor **450**, the inner beam member **592** includes a connector **550** on its end. This connector has ears **554** with holes **552** through them so that the connector **550** can be pinned to the underside of the rotating bed **520**, just as adapter **450** was pinned to rotating bed **420**.

The counterweight support beam movement device comprises a linear actuation device, preferably in the form of a trunnion mounted hydraulic cylinder. The counterweight support beam movement device further comprises ropes and pulleys mounted to the intermediate and outer frame members such that the outer frame member moves in a slave relationship to the movement of the intermediate frame member with respect to the inner frame member. In the preferred embodiment of counterweight support beam **560**, a double acting hydraulic cylinder **540** with a rod **542** is connected between the inner beam member **592** and the middle beam member. Thus as the rod **542** is extended and retracted, the middle beam member **582** moves with respect to the inner beam member **592**. Meanwhile, the outer beam member **532** is connected to the other beam members in a slaved fashion, so that movement of the other beam members with respect to each other necessarily and simultaneously causes a movement of the outer beam member **532** with respect to the middle beam member **582**. The details of how this happens are best seen in FIGS. **42-52**, with additional details in FIGS. **53-60**.

The inner, middle and outer beam members are each made from welded plates into a box structure. Rollers **585** and **586** support the inside surface of outer beam member **532** on the outside of middle beam member **582**. Likewise, rollers **587** and **588** support the inside of middle beam **582** to the outside of inner beam member **592**. The holes **481** and **483** in the sides of counterweight support frame **432** are used to mount rollers **585** and **586** when the member **432** is reused as outer beam member **532** in crane **510**.

To help explain the movement of the beams with respect to each other, some of the drawings, like FIGS. **45-50**, are shown with some of the plate members removed. As best seen in FIGS. **45** and **46**, the hydraulic cylinder is trunnion mounted through mounting **541** to the side walls of the inner beam member **592**. The rod portion **542** of the hydraulic cylinder terminates in a head **539** with a hole through it that can be pinned between lugs **538** welded to the back plate of middle beam **582**. Thus, as the rod **542** inside hydraulic cylinder **540** is extended and retracted, middle beam member **582** will likewise extend and retract with respect to inner beam member **592**.

The movement of the outer beam member **532** is controlled by a pair of retract wire ropes **544** and a pair of extend wire ropes **546**. The extend wire ropes **546** are tied off at one end by connectors **545** to the front of the outer beam member **532**. The extend wire ropes pass through holes **584**, which are the same as unused holes **484** in the counterweight support frame **432**. The extend wire ropes **546** pass around extend sheaves **596** mounted on the rear portion of the middle frame member **582**. The other ends of the extend wire ropes **546** are tied off by connectors **595** to the back of the counterweight support beam connector **550** located at the front of the inner beam member **592**. If the counterweight support beam **560** is in a retracted mode, and the hydraulic cylinder **540** is extended, causing the middle beam member **582** to move backwards with respect to the inner beam

member **592**, the extend sheaves **596** will be pushed backward with the middle beam member, requiring the extend wire ropes **546** to pass around the extend sheaves **596**, necessarily pulling the front of the outer beam member **532** backward by the connections **545**. Because the extend wire ropes **546** are tied off at connectors **545** on the outer beam member **532** and connectors **595** at the front of the inner beam member **592**, but pass around extend sheaves **596** attached to the middle beam member **582**, one foot of travel distance of the middle beam member will cause the outer beam member **532** to extend two feet.

The retract wire ropes **544** are tied off at one end by connectors **543** (FIGS. **49** and **56**) to the rear of the inner beam member **592**. The retract wire ropes pass around retract sheaves **594** mounted on the front portion of the middle beam member **582**. The other ends of the retract wire ropes **544** are tied off by connectors **593** to the back of the outer member **532**. If the counterweight support beam **560** is in an extended mode, and the hydraulic cylinder **540** is retracted, causing the middle beam member **582** to move forward with respect to the inner beam member **592**, the retract sheaves **594** will be pushed forward with the middle beam member; requiring the retract wire ropes **544** to pass around the retract sheaves **594**, necessarily pulling the rear of the outer beam member forward by the connectors **593**. Because the retract wire ropes are tied off at connectors **543** to the inner beam member, but pass around retract sheaves **594** attached to the middle beam member **582**, one foot of travel distance of the middle beam member will cause the outer beam member **532** to retract two feet. The retract wire ropes **544** could attach to the outer beam member **532** at any point in the beam behind where the retract sheaves **594** are located when the beam is retracted. However, by having the retract wire ropes **544** tie off at the very rear of the outer beam member **532**, the connectors **593** are more readily accessible if adjustment is needed.

It will be noticed from FIGS. **58** and **59** that the rollers **588** have flanges on the outside to help keep the beams aligned side-to-side. Rollers **585**, **586** and **587** also have such flanges. Preferably the rollers **585**, **586**, **587** and **588** are mounted in the side of the middle beam member **582** with bearings between the roller shaft and the roller, although no bearings are shown in the figures. Also, it is not clear from the drawings, but one of ordinary skill in the art will understand that there is a slight clearance on the sides and the top or bottom of the rollers compared to the beam members supported thereon.

FIGS. **61** and **62** show an alternative arrangement for the connection between the rear of the rotating bed **420** and the counterweight support frame **432** when the crane is set up without the fixed mast **517** (when the crane is set up in its first counterweight set-up configuration), as well as an alternative arrangement for the connection between the telescoping counterweight support beam **560** and the tension members **531** when the crane is set up in its second counterweight set-up configuration. Rather than using short links **462**, the support on the rear of the rotating bed in the form of lugs **523** are located at a position where they can be pinned directly to lugs **620** on outer beam member **532**, used as part of counterweight support beam **560** in the embodiment shown in FIGS. **61** and **62**. Like the lugs **566**, lugs **620** are each made of two plates with holes through them used for making a pinned connection with either the rotating bed (when the crane is set up in its first counterweight set-up configuration), or the bottom of a tension member **531** (when the crane is set up in its second counterweight set-up configuration). In the first counterweight set-up configura-

tion, pins (not shown) pass through holes **632** in the lugs **620** and holes **562** in the lugs **523**.

One of the benefits of the lugs **620** is that they include a top bar **624** and lower bar **626** between plates **621** and **622** that engage with the lug **523** on rotating bed **520** when the counterweight support beam **560** is fully retracted, as shown in FIG. **62** (where the left side plate has been removed for sake of clarity). Thus, the support **523** on the rear of the rotating bed engages with a counterweight beam support engagement (bars **624**) positioned such that when the counterweight beam is in a fully retracted position, the support and the support engagement are able to transfer load from the counterweight beam directly to the rotating bed. At high boom angles, with no load on the hook, the moment of the counterweight system may exceed the offsetting moment of the combined boom and load moment as seen by the fixed mast **517**. In that situation, the fixed mast will try to move backward and will compress the fixed mast stops **529** until the top bars **624** on the outer beam member lugs **620** engage the lug **523** on the rotating bed **520**. (It should be noted that when the crane is set up with mast **517**, no pins are placed in holes **562** and **632**. These holes just also happen to line up when the tension member **531** is pinned to the lugs **620** and the counterweight support beam **560** is fully retracted.) At that point the rear of the rotating bed will be carrying part of the counterweight load, reducing the tendency of the mast **517** to tip backwards any further.

Preferably the counterweight unit is moveable to a position so that the center of gravity of the counterweight unit is within a distance from the axis of rotation of less than 125% of the distance from the axis of rotation to the rear tipping fulcrum, and more preferably within a distance from the axis of rotation of less than 110% of the distance from the axis of rotation to the rear tipping fulcrum.

As noted above, prior art mobile lift cranes generally had multiple counterweight assemblies. The variable position counterweight of the preferred crane has only one counterweight assembly. Where the conventional designs require 330 metric tonne of counterweight, the crane **10** with a single variable position counterweight will require approximately 70% of this amount, or 230 metric tonne of counterweight, to develop the same load moment. The 30% counterweight reduction directly reduces the cost of the counterweight, although this cost is partially offset by the cost of the counterweight movement system. Under current U.S. highway constraints, 100 metric tonne of counterweight requires five trucks for transport. Thus, reducing the total counterweight reduces the number of trucks required to transport the crane between operational sites. Because the counterweight is reduced significantly, the maximum ground bearing reactions are also reduced by the same amount. The counterweight is positioned only as far rearward as required to lift the load. The crane and counterweight remain as compact as possible and only expand when additional load moment is required. A further feature is the capability to operate with reduced counterweight in the mid-position. The reduced counterweight would balance the backward stability requirements when no load is applied to the hook. The variable position function could then be turned off and the crane would operate as a traditional lift crane. With preferred embodiments of the invention, the total counterweight compared to a crane with a comparable capacity can be reduced, or if the total counterweight is the same, the stability of the crane can be increased or the crane can be designed with a smaller footprint. Of course some combination of all three of these advantages may be used in producing a new crane model.

A crane customer may initially decide to purchase and use the crane **410** with only the counterweight support frame **432**, and not include an inner beam member **592** and middle beam member **582**, nor the fixed mast **517**. Then later the crane **410** could be converted to crane **510** by adding the fixed mast **517** and inserting the inner beam member **592** and middle beam member **582** into the counterweight support frame **432**, making the counterweight support beam **560**. Thereafter, inner beam member **592** and middle beam member **582** could be removed when the crane was set up without the fixed mast **517**. However, it is more likely that the counterweight support beam **560** would remain intact once assembled, and used on the crane **410** without being extended, but simply used as a counterweight support frame **432**.

In the first counterweight set-up configuration option (crane **10** or crane **410**), the counterweight unit is not supported by a fixed mast or a derrick mast. Rather, the counterweight unit is supported on a counterweight support frame on the rotating bed. A counterweight movement system comprises a counterweight unit movement device connected so as to move the counterweight unit with respect to the counterweight support frame. In the second counterweight set-up configuration option (crane **110** or crane **510**), the second counterweight unit is supported by a mast selected from a fixed mast and a derrick mast. A counterweight support beam is moveably connected to the rotating bed and the counterweight unit is supported on the counterweight support beam. The counterweight movement system comprises a counterweight support beam movement device connected so as to move the counterweight support beam with respect to the rotating bed. In the crane **110**, the counterweight support beam is moveably connected to the rotating bed by being moveably connected to the counterweight support frame. In the crane **510**, the counterweight support beam is moveably connected to the rotating bed by having a telescoping section that moves is moveably connected to the rotating bed by a front portion of the counterweight support beam.

In the first counterweight set-up configuration option, the crane **10** or crane **410** includes a counterweight tray moveably supported on the counterweight support frame and counterweights are stacked directly on the counterweight tray. In the second counterweight set-up configuration option of crane **110**, the counterweight support beam is attached to the counterweight tray and counterweights are stacked on the counterweight support beam by being stacked on a base plate that is on the counterweight support beam.

With the embodiments of cranes **110** and **510**, a method of operating the mobile lift crane involves performing a pick, move and set operation with a load wherein the moveable counterweight unit is moved toward and away from the front portion of the rotating bed during the pick, move and set operation to help counterbalance the combined boom and load moment, and wherein the counterweight unit stays on the counterweight support beam during the pick, move and set operation. The counterweight support beam and counterweight unit both move to counterbalance the crane as the combined boom and load moment changes. Further, the counterweight unit may be moved with respect to the counterweight support beam during the pick, move and set operation to help counterbalance the combined boom and load moment.

Preferred cranes of the present invention have a moveable upperworks counterweight unit that rotates with the rotating bed and a counterweight movement system connected between the rotating bed and the counterweight unit. The

counterweight unit may be moved to and held at both a forward position and a rearward position, but is never supported by the ground during crane pick, move and set operations other than indirectly by the moveable ground engaging members on the carbody. The ratio of i) the weight of the upperworks counterweight unit to ii) the total weight of the crane equipped with a basic boom length is greater than 52%, preferably greater than 60%. In some embodiments, the counterweight unit is supported on a counterweight support frame that is provided as part of the rotating bed, and the counterweight unit is in a moveable relationship with respect to the counterweight support frame.

The invention is particularly applicable to cranes that have a capacity of between 200 and 1500 metric tonne, and more preferably between 300 and 1200 metric tonne.

It will be appreciated that the invention includes a method of increasing the capacity of a crane. A lift crane having a first capacity can be modified to become a crane having a second capacity greater than the first capacity. The crane of the first capacity includes a counterweight unit having multiple counterweights stacked on top of each other. The counterweight unit is moveable from a first position to a second position further from the crane boom than the first position. The method involves removing at least some of the counterweights from the crane; adding a counterweight support beam to the crane; and returning at least some of the counterweights back to the crane to provide the crane with the greater capacity. The returned counterweights are supported on the counterweight support beam in a manner that allows the returned counterweights to be able to move to a third position further from the boom than the second position. As disclosed, in some embodiments, the counterweight support beam is attached to the rotating bed by being attached to a counterweight support beam movement device that is attached directly to the rotating bed, and the counterweight support beam movement device is connected between the counterweight support beam and the rotating bed such that the counterweight support beam can be moved with respect to the length of the rotating bed away from the rotational connection of the rotating bed and the carbody. In some methods of the invention, the returned counterweights move to the third position by moving with the counterweight support beam, or by moving with respect to the counterweight support beam, or by moving with the counterweight support beam and moving with respect to the counterweight support beam. As discussed above, the step of adding the counterweight support beam may involve removing an outer frame structure connected to the rotating bed by an adapter, assembling that outer frame structure with a telescoping inner frame structure to create the counterweight support beam movement device, and attaching the inner structure to the rotating bed.

It should be understood that various changes and modifications to the presently preferred embodiments described herein will be apparent to those skilled in the art. For example, the boom hoist system could comprise one or more hydraulic cylinders mounted between the boom and the rotating bed to change the angle of the boom instead of a live mast or lattice mast, a fixed gantry could be used to support boom hoist rigging. In this regard, such a gantry is considered to be a mast for purposes of the following claims. The crane 10 could be modified to include a lattice mast such as is used on crane 110 but with just the moveable counterweight on counterweight support frame 32 rather than with a counterweight support beam 160, in which case the boom hoist rigging would include an equalizer between the lattice mast and the boom. If the crane is set up this way on a job

site, it can perform smaller lifts as initially set up, and then have the counterweight support beam 160 added to make the crane 110 without having to set up the crane again. Further, parts of the crane need not always be directly connected together as shown in the drawings. For example, the tension member could be connected to the mast by being connected to a backhitch near where the backhitch is connected to the mast. Such changes and modifications can be made without departing from the spirit and scope of the present invention and without diminishing its intended advantages. It is therefore intended that such changes and modifications be covered by the appended claims.

What is claimed is:

1. A mobile lift crane adapted to be configured in both a first configuration and a second configuration, the mobile lift crane comprising:

- a) a carbody;
- b) moveable ground engaging members mounted on the carbody allowing the crane to move over the ground;
- c) a rotating bed rotatably connected to the carbody about an axis of rotation; and
- d) a boom pivotally mounted on the rotating bed and including a hoist line for handling a load;
- e) a counterweight support frame connected to the rotating bed;
- f) a moveable counterweight unit;
- g) wherein in the first configuration,
 - i. a first mast is connected to the boom;
 - ii. a second mast pivotally is connected to the rotating bed, the second mast being connected to the first mast during at least a first pick, move, and set operation;
 - iii. a moveable counterweight support beam is coupled to the counterweight support frame and configured to move relative to the counterweight support frame while moving toward and away from the boom for use during the at least first pick, move, and set operation; and
- h) wherein in the second configuration,
 - i. the first mast is absent from the mobile lift crane; and
 - ii. the mobile lift crane is configured such that it can perform at least a second pick, move, and set operation where the first mast is absent and the second mast is connected to the boom and the second mast can pivot in order to change the angle of the boom; and
- i) wherein in the first and second configuration, the moveable counterweight unit is never supported by the ground other than indirectly by the moveable ground engaging members on the carbody during the at least first pick, move, and set operation and the at least second pick, move, and set operation;
- m) wherein the mobile crane is adapted to be configured according to the first and the second configuration by at least:
 - (i) suspend the moveable counterweight unit adapted to (i) suspend below the rotating bed such that the moveable counterweight unit is operable to support counterweights positioned on opposing sides of the rotating bed and (ii) couple alternatively to the moveable counterweight support beam in the first configuration and to the counterweight support frame in the second configuration; and
 - the counterweight support frame adapted to couple alternatively to the moveable counterweight support beam and the moveable counterweight unit such that the moveable counterweight support beam is oper-

31

able to move toward and away from the boom in the first configuration and the moveable counterweight unit is operable to move toward and away from the boom in the second configuration.

2. The mobile lift crane of claim 1 further comprising a telescoping cylinder in the first configuration operable to move the moveable counterweight support beam relative to the counterweight support frame.

3. The mobile lift crane of claim 1 further comprising a tension member connected to the first mast operable to provide at least some support for the weight of the moveable counterweight unit.

4. The mobile lift crane of claim 3 wherein the tension member is configured to be removable from the mobile lift crane; and

wherein the mobile lift crane is configured such that if the tension member were removed from the mobile lift crane, the mobile lift crane could perform the at least second pick, move, and set operation.

5. The mobile lift crane of claim 1 wherein the moveable counterweight support beam comprises a telescoping beam.

6. The mobile lift crane of claim 1 wherein the counterweight support frame and the moveable counterweight support beam are located below a remainder of the rotating bed.

7. The mobile lift crane of claim 1 wherein a percentage ratio of a counterweight capacity of the moveable counterweight unit to a total weight of the crane is greater than 52%.

8. The mobile lift crane of claim 1 wherein

a) the moveable counterweight unit is configured for use during the at least second pick, move, and set operation to move between a first position and a second position, wherein the first position is defined as a position in which the moveable counterweight unit is as near as the moveable counterweight unit can be moved by a counterweight movement system to the axis of rotation during the at least second pick, move, and set operation, constituting a first distance from the axis of rotation, and the second position is defined as a position in which the moveable counterweight unit is as far as the moveable counterweight unit can be moved by the counterweight movement system from the axis of rotation during the at least second pick, move, and set operation, constituting a second distance from the axis of rotation;

b) the moveable counterweight unit is further configured for use during the at least first pick, move, and set operation to move between a third position and a fourth position, wherein the third position is defined as a position in which the moveable counterweight unit is as near as the moveable counterweight unit can be moved by the counterweight movement system to the axis of rotation during the at least first pick, move, and set operation, constituting a third distance from the axis of rotation, and the fourth position is defined as a position in which the moveable counterweight unit is as far as the moveable counterweight unit can be moved by the counterweight movement system from the axis of rota-

32

tion during the at least first pick, move, and set operation, constituting a fourth distance from the axis of rotation; and

c) the fourth distance is greater than the second distance.

9. The mobile lift crane of claim 8 wherein the difference between the third and fourth distances is at least 1.5 times as large as the difference between the first and second distances.

10. The mobile lift crane of claim 1 wherein a tension member is connected between the first mast and the moveable counterweight support beam during the at least first pick, move, and set operation.

11. The mobile lift crane of claim 1 wherein the moveable counterweight support beam is configured to be removable from the mobile lift crane; and

wherein the mobile lift crane is configured such that if the moveable counterweight support beam were removed from the mobile lift crane, the mobile lift crane could perform the at least second pick, move, and set operation with the moveable counterweight unit moving toward and away from the boom and relative to the counterweight support frame.

12. The mobile lift crane of claim 1 further comprising one or more counterweight unit movement devices configured to move the moveable counterweight unit toward and away from the boom;

wherein the one or more counterweight unit movement devices are configured to move the moveable counterweight unit to a position where the moveable counterweight unit is in front of the rearmost fixed portion of the rotating bed.

13. The mobile lift crane of claim 1 further comprising one or more counterweight unit movement devices configured to move the moveable counterweight unit toward and away from the boom;

wherein the one or more counterweight unit movement devices are configured to move the moveable counterweight unit to a position where the moveable counterweight unit is in front of the top of the first mast.

14. The mobile lift crane of claim 1 wherein the second mast is configured to be disabled from pivoting during at least the first pick, move, and set operation.

15. The mobile lift crane of claim 1 wherein in the second configuration the moveable counterweight support beam is absent from the mobile lift crane.

16. The mobile lift crane of claim 1 wherein in the first configuration the crane further comprises a tension member disposed between the first mast and the moveable counterweight support beam supporting the moveable counterweight support beam.

17. The mobile lift crane of claim 1 wherein in the first configuration the second mast is pivotally connected to the rotating bed proximate the boom.

18. The mobile lift crane of claim 1 wherein the moveable counterweight unit is operable to move toward and away from the boom in the second configuration while the mobile lift crane is loaded.

* * * * *