

US010411362B2

(12) **United States Patent**
Hreha et al.

(10) **Patent No.:** **US 10,411,362 B2**
(45) **Date of Patent:** **Sep. 10, 2019**

(54) **SYNCHRONIZATION FOR SATELLITE SYSTEM**

(71) Applicant: **Space Systems/Loral, LLC**, Palo Alto, CA (US)

(72) Inventors: **William Hreha**, San Jose, CA (US); **Anne Elizabeth Wharton**, Boulder Creek, CA (US); **David Linford Foulke**, Mountain View, CA (US); **Richard Wallace Voreck**, Portola Valley, CA (US); **Shervin Shambayati**, San Carlos, CA (US)

(73) Assignee: **Space Systems/Loral, LLC**, Palo Alto, CA (US)

(*) Notice: Subject to any disclaimer, the term of this patent is extended or adjusted under 35 U.S.C. 154(b) by 196 days.

(21) Appl. No.: **15/172,859**

(22) Filed: **Jun. 3, 2016**

(65) **Prior Publication Data**

US 2017/0289939 A1 Oct. 5, 2017

Related U.S. Application Data

(60) Provisional application No. 62/314,938, filed on Mar. 29, 2016.

(51) **Int. Cl.**
H01Q 21/24 (2006.01)
H04W 16/28 (2009.01)
(Continued)

(52) **U.S. Cl.**
CPC **H01Q 21/24** (2013.01); **H01Q 3/2682** (2013.01); **H04B 7/043** (2013.01);
(Continued)

(58) **Field of Classification Search**

CPC H04W 56/0015; H04W 16/28; H04B 7/18519; H04B 7/185-7/2128

See application file for complete search history.

(56) **References Cited**

U.S. PATENT DOCUMENTS

4,048,563 A * 9/1977 Osborne G01S 11/10 375/367
5,784,695 A 7/1998 Upton
(Continued)

FOREIGN PATENT DOCUMENTS

EP 0961420 12/1999

OTHER PUBLICATIONS

Experiment Applicants Guide, Advance Communications Technology Satellite, Aug. 26, 1988.*

(Continued)

Primary Examiner — Raymond S Dean

(74) *Attorney, Agent, or Firm* — Vierra Magen Marcus LLP

(57) **ABSTRACT**

Synchronization technology is implemented for a satellite communication system. Master clock information is accessed at a terrestrial location. A timing message based on the master clock information is transmitted from the terrestrial location to a satellite as the satellite is in orbit. The satellite is synchronized to the master clock based on the timing message. A beacon signal is transmitted from the satellite toward Earth. The beacon signal includes timing information. The beacon signal is received at a ground based gateway. The gateway is synchronized to the satellite based on the beacon signal. Communication is sent from the gateway to a terminal via the satellite. The communication includes timing data. The terminal is synchronized to the gateway based on the timing data.

26 Claims, 54 Drawing Sheets

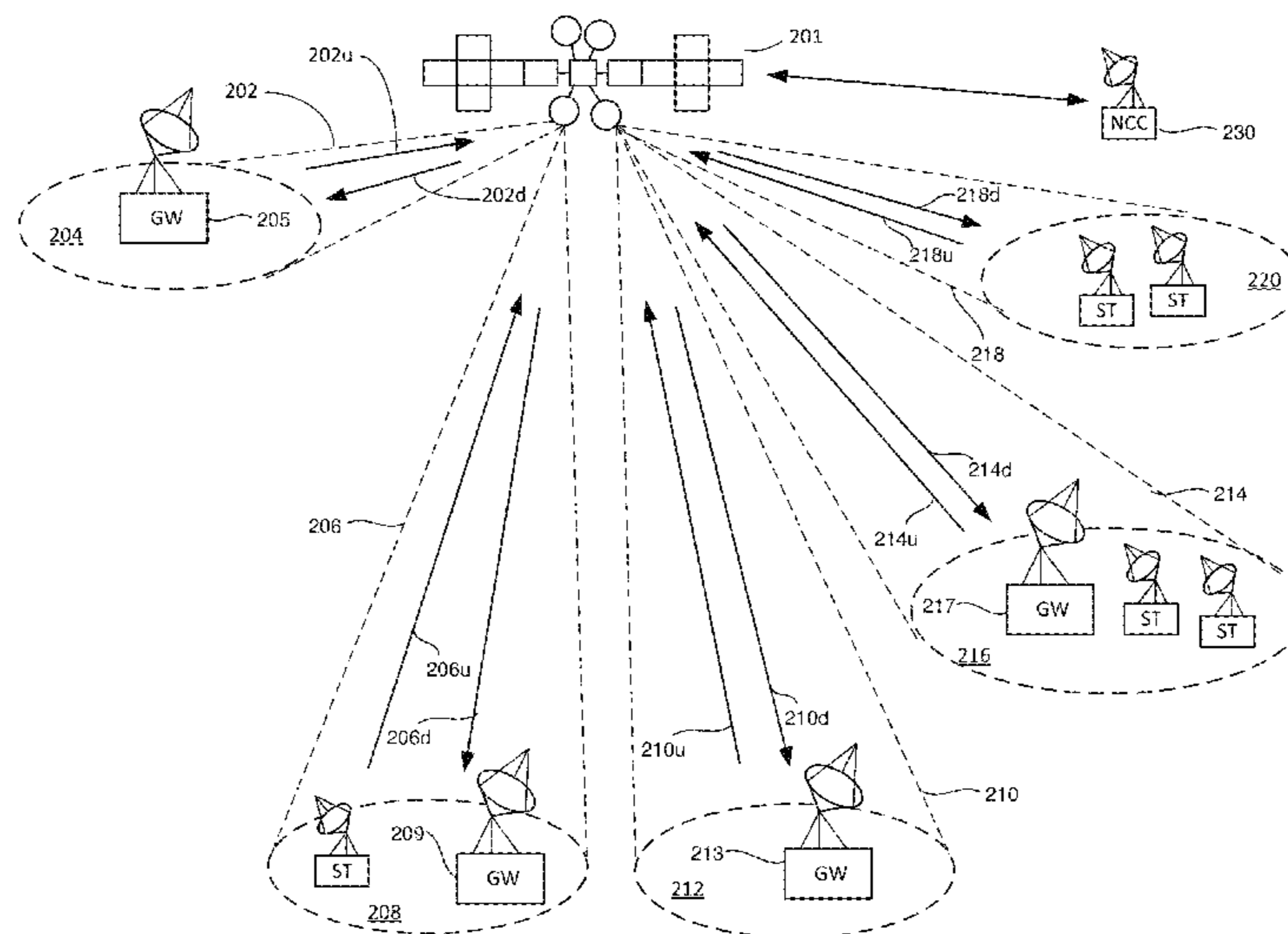

- (51) **Int. Cl.**
- | | | | | |
|--------------------|-----------|-------------------|---------|---|
| <i>H04B 7/185</i> | (2006.01) | 7,869,759 B2 | 1/2011 | Pateros |
| <i>H04W 72/04</i> | (2009.01) | 8,077,652 B2 | 12/2011 | Thesling |
| <i>H04W 56/00</i> | (2009.01) | 8,218,476 B2 | 7/2012 | Miller |
| <i>H01Q 3/26</i> | (2006.01) | 8,315,199 B2 | 11/2012 | Dankberg |
| <i>H04B 7/0426</i> | (2017.01) | 8,340,016 B1 | 12/2012 | Miller |
| <i>H04W 84/18</i> | (2009.01) | 8,401,467 B2 | 3/2013 | Miller |
| <i>H04B 7/19</i> | (2006.01) | 8,427,999 B2 | 4/2013 | Foxworthy |
| | | 8,433,332 B2 | 4/2013 | Agarwal |
| | | 8,494,445 B2 | 7/2013 | Miller |
| | | 8,712,321 B1 | 4/2014 | Dankberg |
| | | 8,805,275 B2 | 8/2014 | O'Neill |
| | | 8,989,652 B2 | 3/2015 | Whelan |
| | | 8,995,943 B2 | 3/2015 | Corman |
| | | 9,014,620 B2 | 4/2015 | Dankberg |
| | | 9,130,644 B2 | 9/2015 | Jayasinha |
| | | 2003/0202529 A1 * | 10/2003 | Jarett H04B 7/2041
370/437 |
| | | 2007/0085735 A1 * | 4/2007 | Bay G01S 19/50
342/357.33 |
| | | 2013/0063308 A1 * | 3/2013 | Krasner G01S 19/05
342/393 |
| | | 2013/0293414 A1 * | 11/2013 | Robinson G01S 19/05
342/357.25 |
| | | 2015/0131523 A1 * | 5/2015 | Balter H04B 7/18515
370/317 |
| | | 2015/0158602 A1 | 6/2015 | Marshack |
| | | 2017/0269226 A1 * | 9/2017 | Dai G01S 19/41 |
- (52) **U.S. Cl.**
- CPC *H04B 7/18515* (2013.01); *H04B 7/18519* (2013.01); *H04B 7/18523* (2013.01); *H04B 7/18534* (2013.01); *H04B 7/18541* (2013.01); *H04B 7/18578* (2013.01); *H04B 7/18584* (2013.01); *H04W 16/28* (2013.01); *H04W 56/0015* (2013.01); *H04W 72/042* (2013.01); *H04W 72/0413* (2013.01); *H04W 72/0446* (2013.01); *H04W 72/0453* (2013.01); *H04B 7/18513* (2013.01); *H04B 7/18521* (2013.01); *H04B 7/18547* (2013.01); *H04B 7/18595* (2013.01); *H04B 7/19* (2013.01); *H04W 72/046* (2013.01); *H04W 84/18* (2013.01)
- (56) **References Cited**

U.S. PATENT DOCUMENTS

- | | | | |
|----------------|---------|------------------|-------------------------|
| 5,936,570 A * | 8/1999 | Ghazvinian | H04B 7/18532
342/354 |
| 6,491,257 B1 | 12/2002 | Emmons, Jr. | |
| 6,539,003 B1 | 3/2003 | Agarwal | |
| 6,684,056 B1 | 1/2004 | Emmons, Jr. | |
| 6,726,152 B2 | 4/2004 | Higgins | |
| 6,766,987 B2 | 7/2004 | Taormina | |
| 6,850,732 B2 | 2/2005 | Patterson | |
| 6,904,265 B1 | 6/2005 | Valdivia | |
| 6,992,992 B1 | 1/2006 | Cooper | |
| 7,245,930 B1 * | 7/2007 | Vishwanath | H04B 7/18532
370/350 |
| 7,263,090 B2 | 8/2007 | Cronin | |

OTHER PUBLICATIONS

- DVB Fact Sheet—2nd Generation Satellite, DVB S2, Aug. 2012.
- Digital Video Broadcasting, Second generation framing structure, channel coding and modulation systems for Broadcasting, Interactive Services, News Gathering and other broadband satellite applications, Part I (DVB-52), Nov. 2014.
- Digital Video Broadcasting, Implementation guidelines for the second generation system for Broadcasting, Interactive Services, News Gathering and other broadband satellite applications, Part I (DVB-S2), Mar. 2015.
- Search Report and Written Opinion dated Sep. 27, 2018 in French Patent Application No. FR1752603.

* cited by examiner

Figure 2

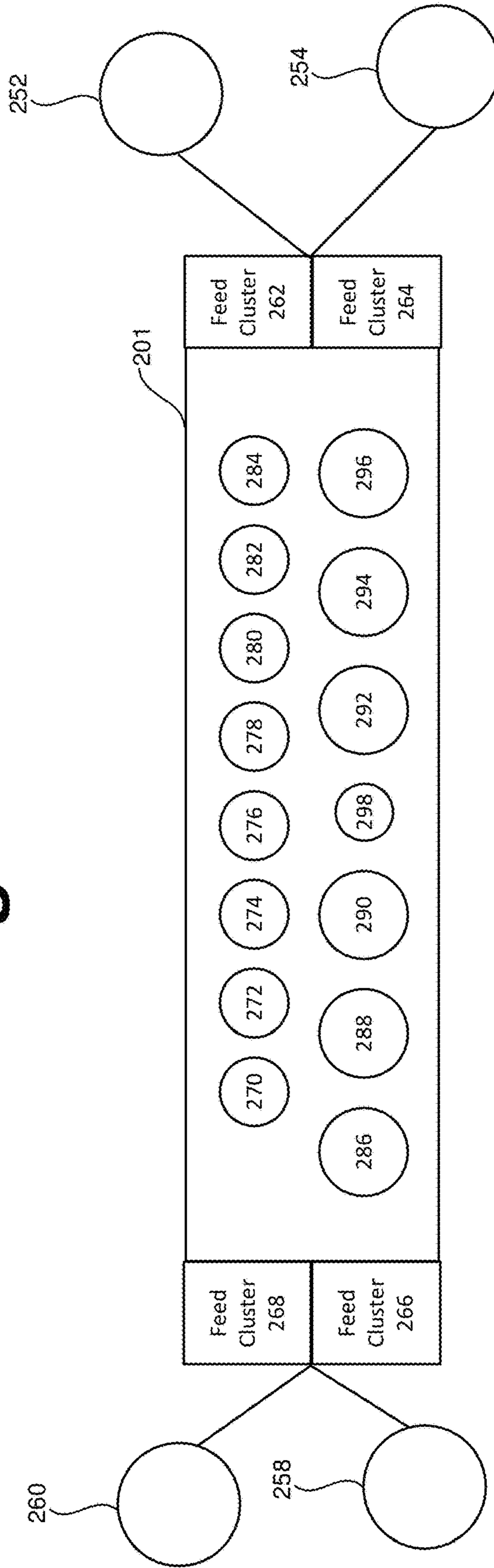
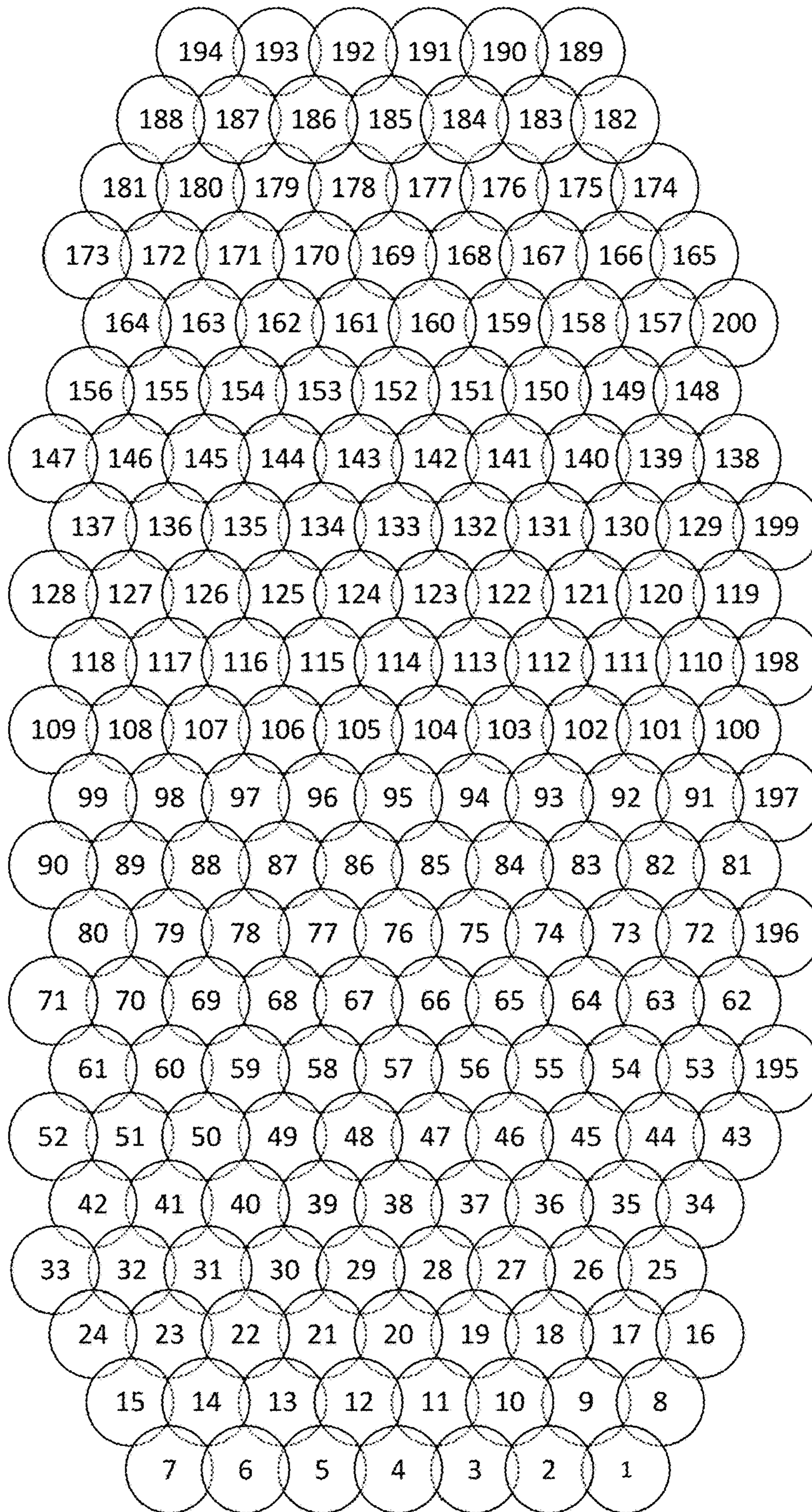

Figure 3



Field of Regard

Figure 4

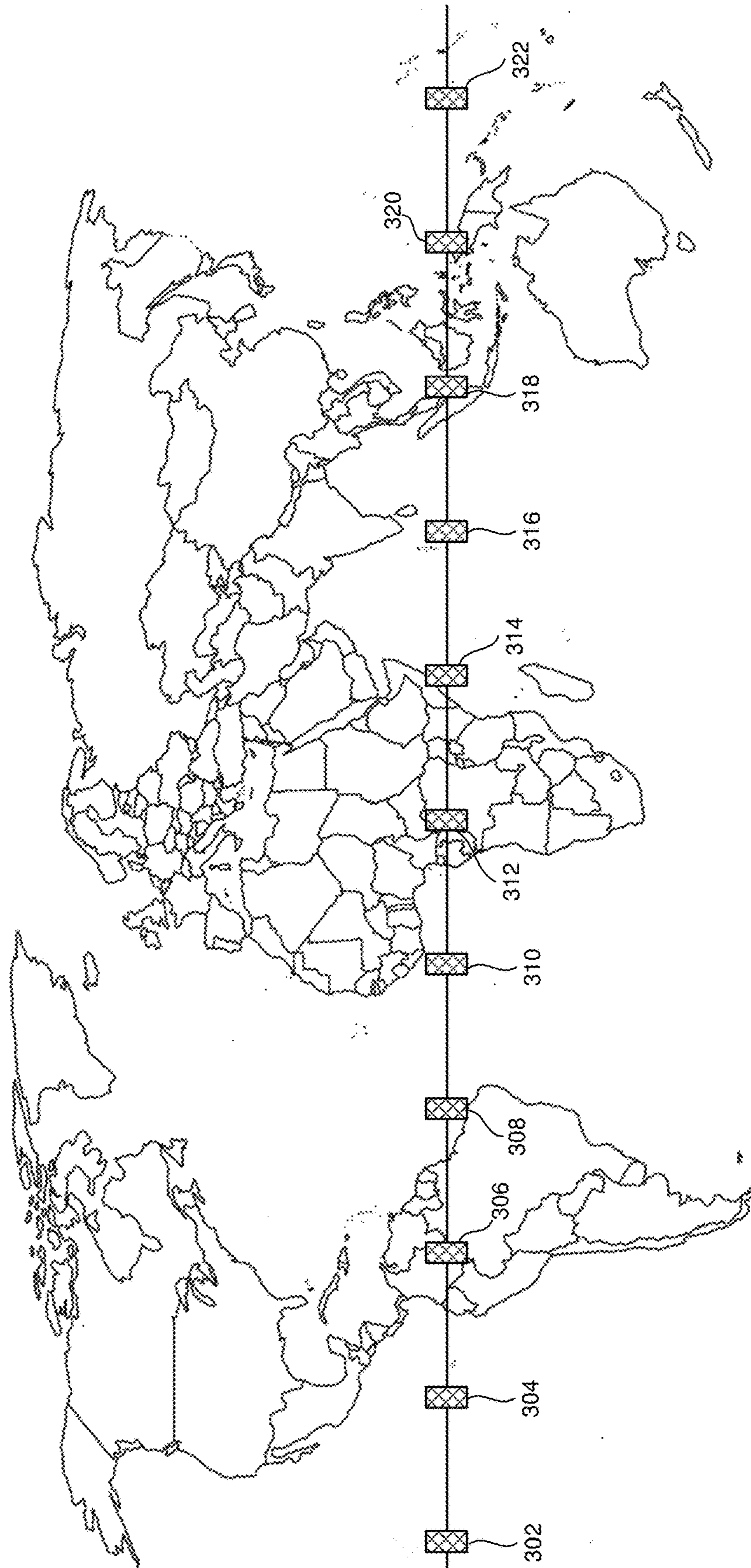

Figure 5

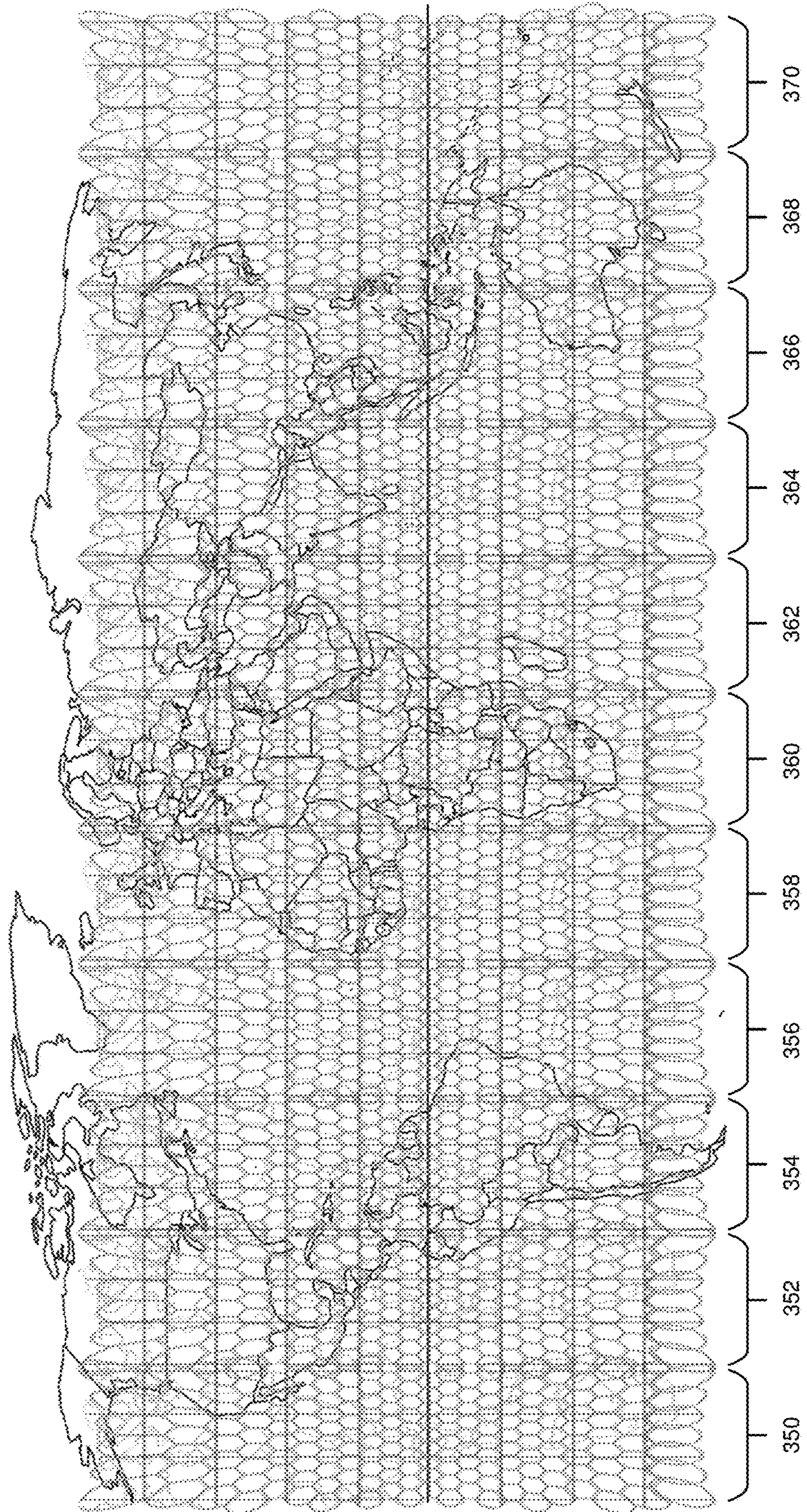

Figure 7

442

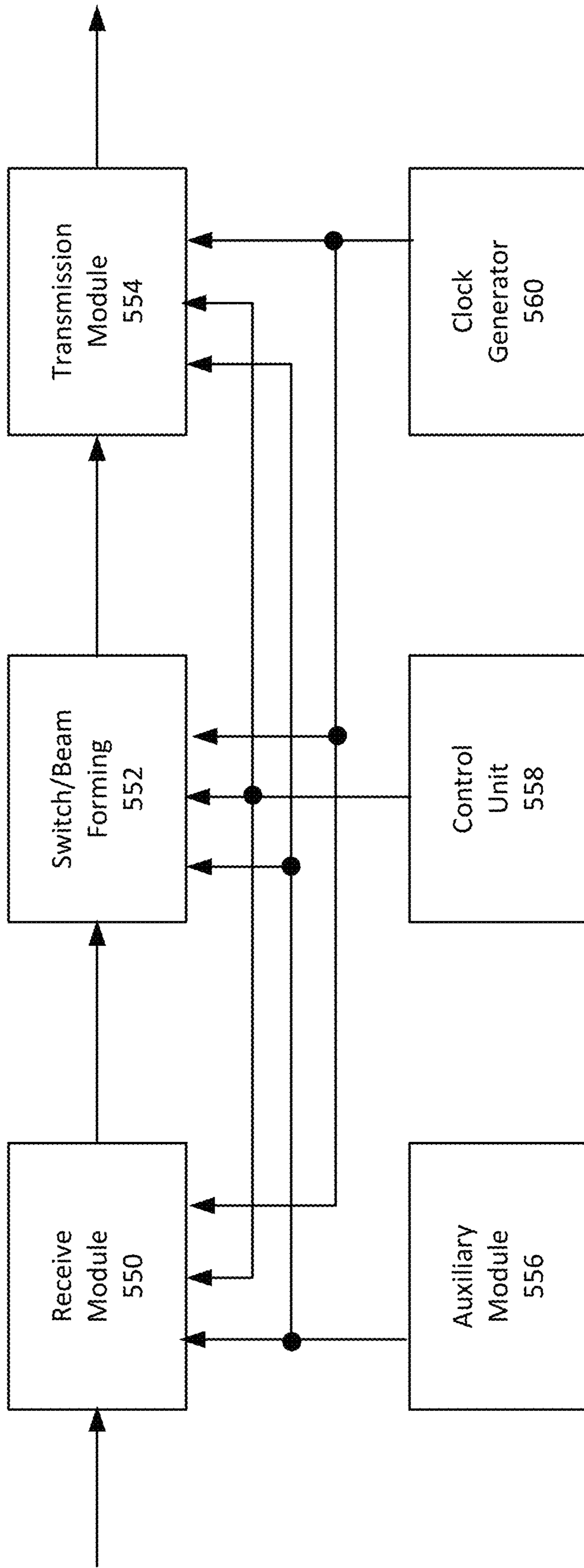

Figure 8

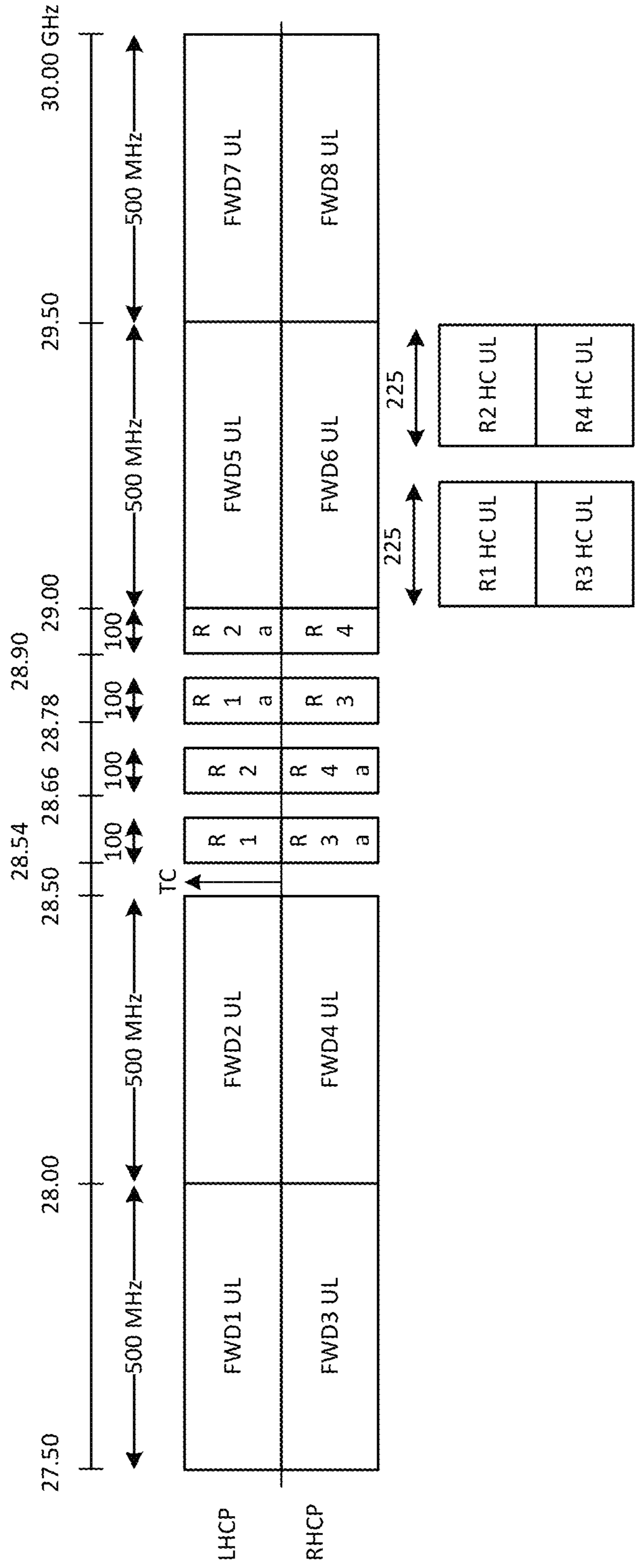

Figure 9

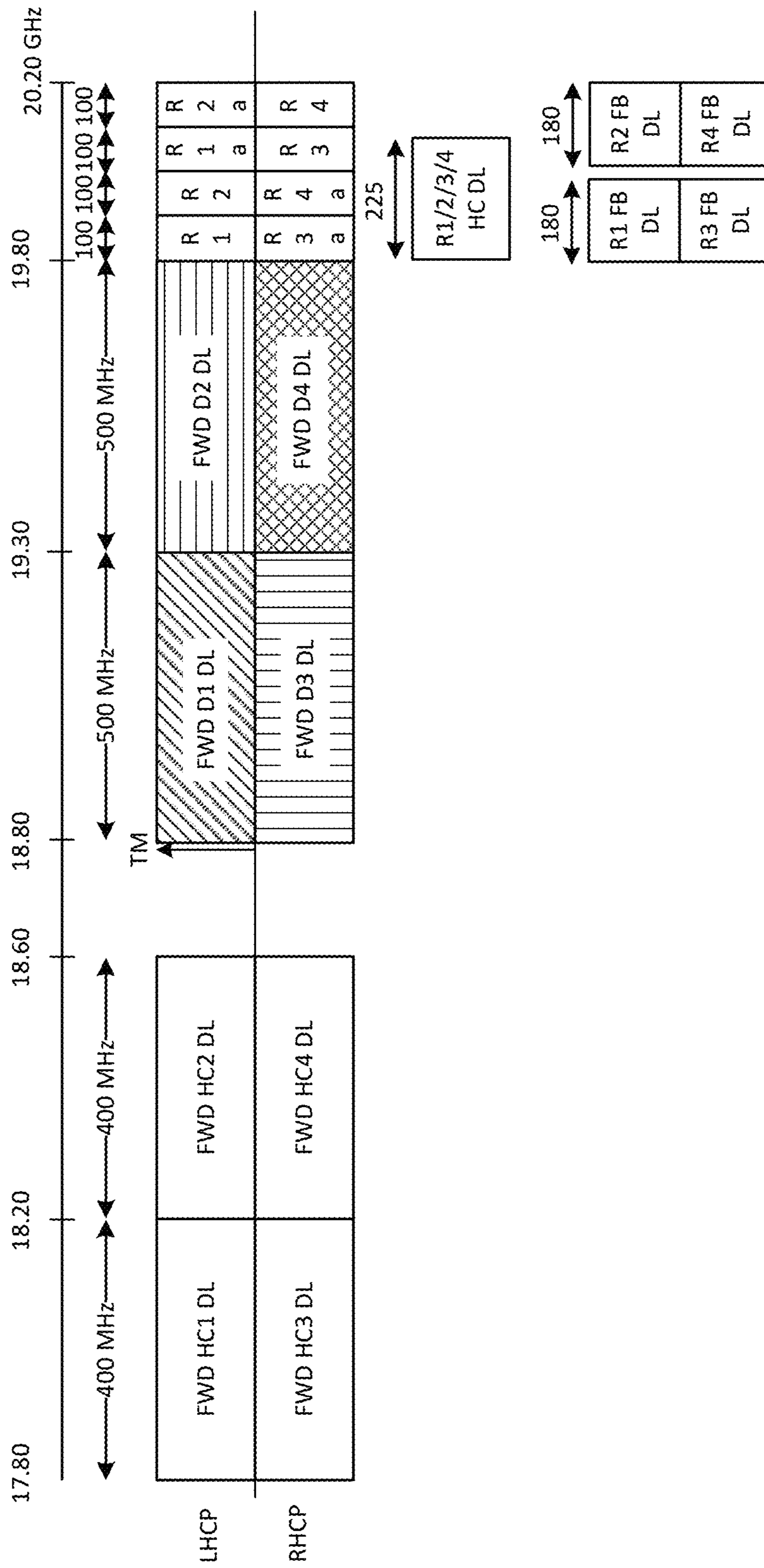

Figure 10

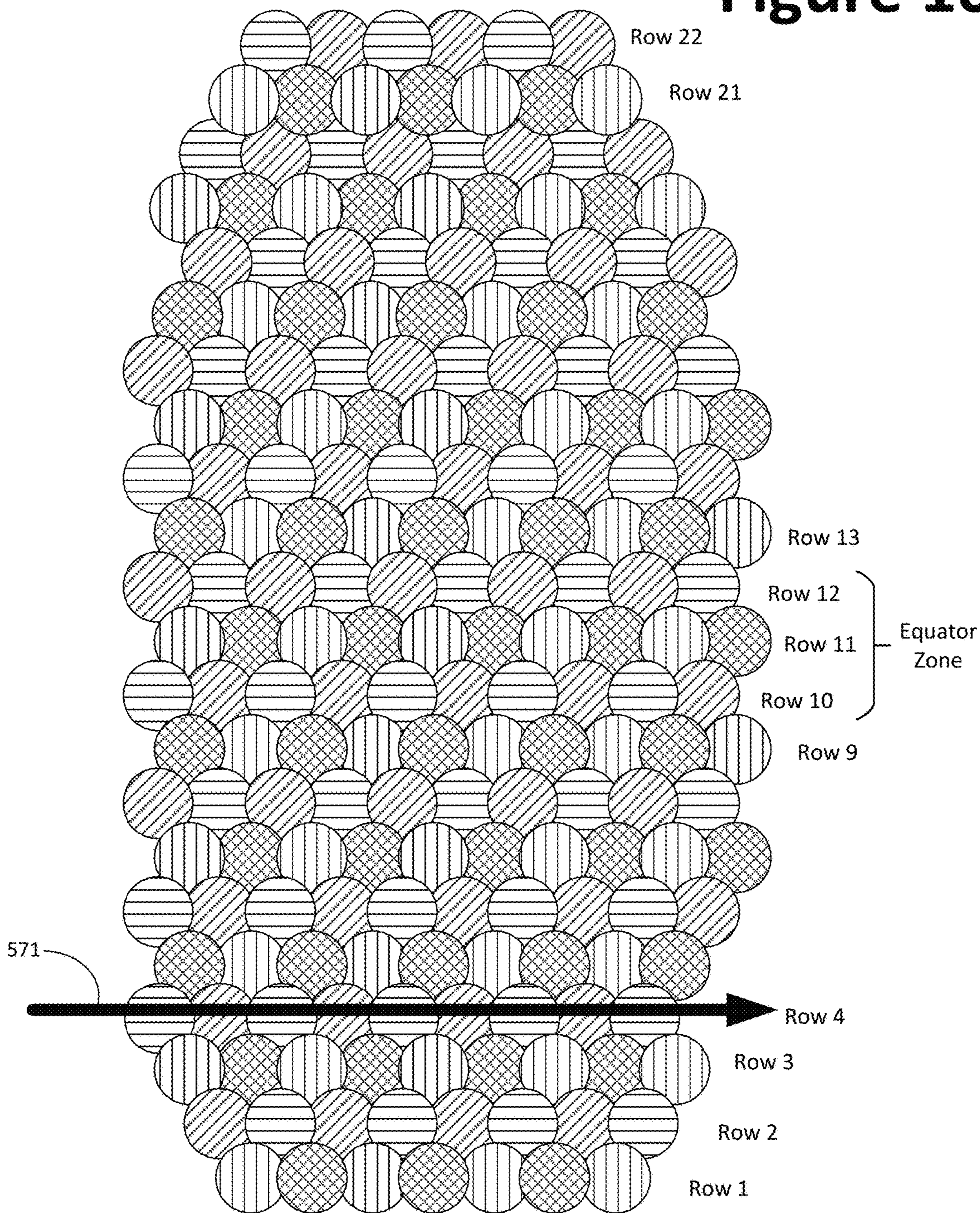

Figure 11

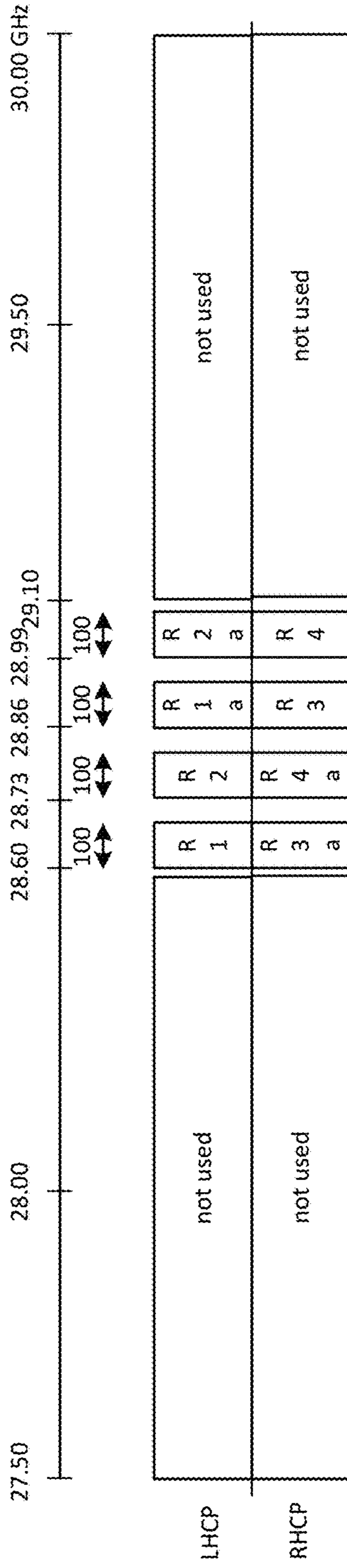

Figure 12

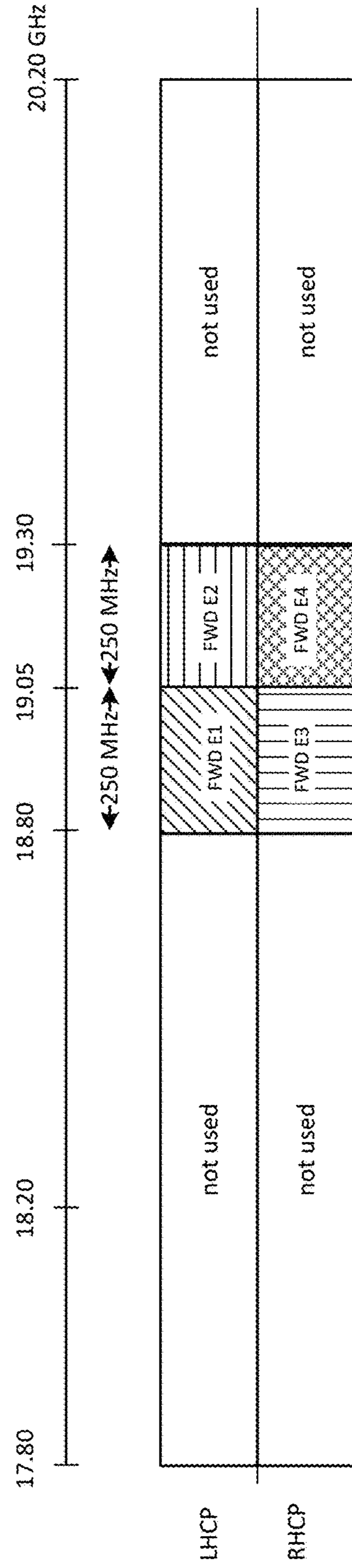

Figure 13

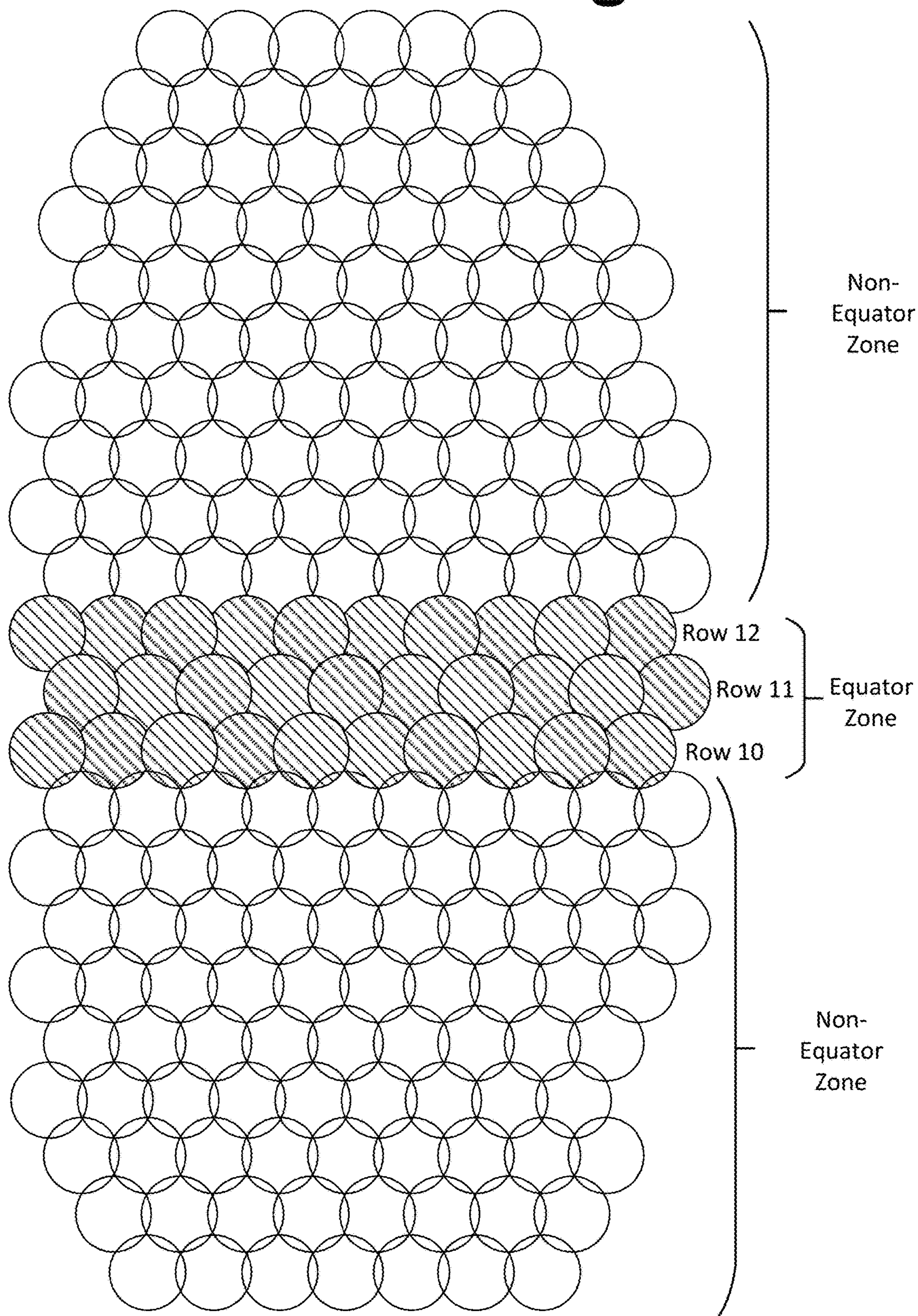

Figure 13A

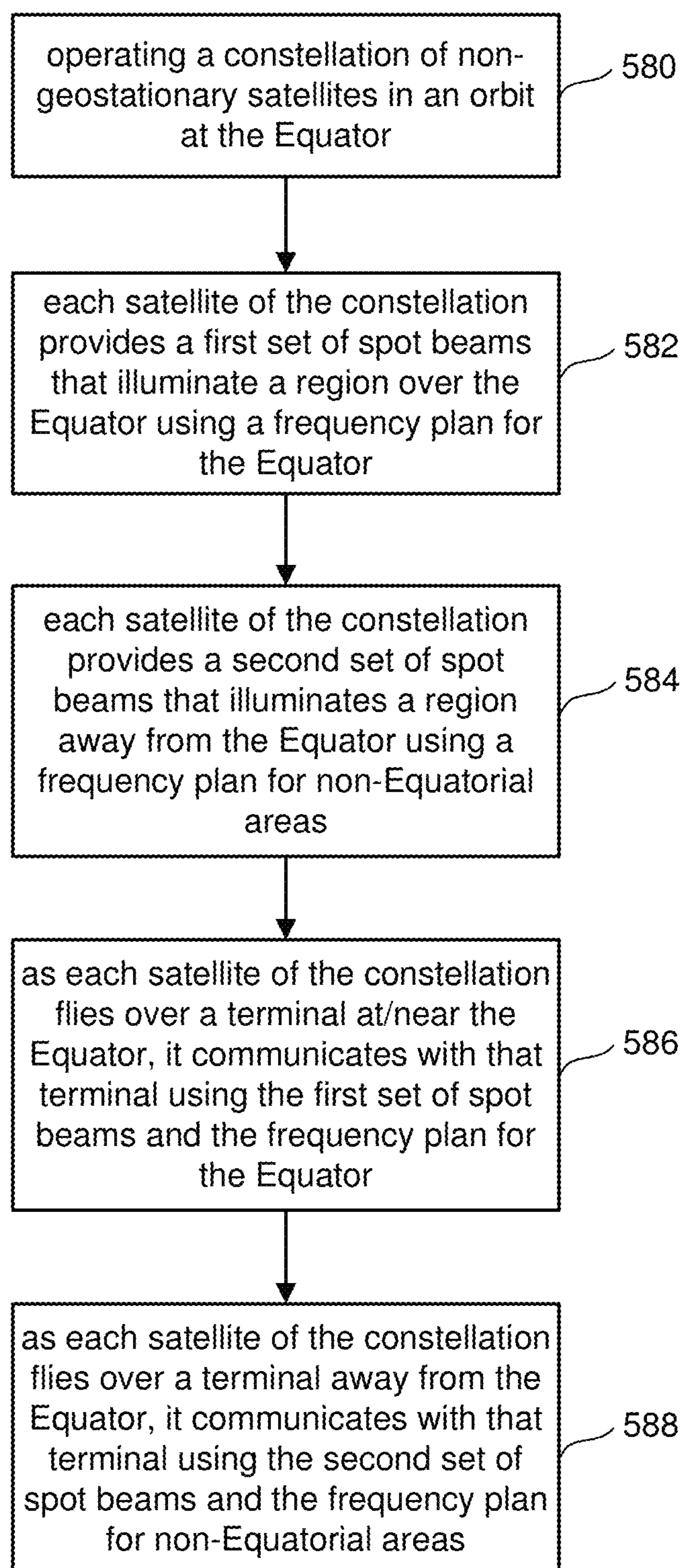

Figure 14A

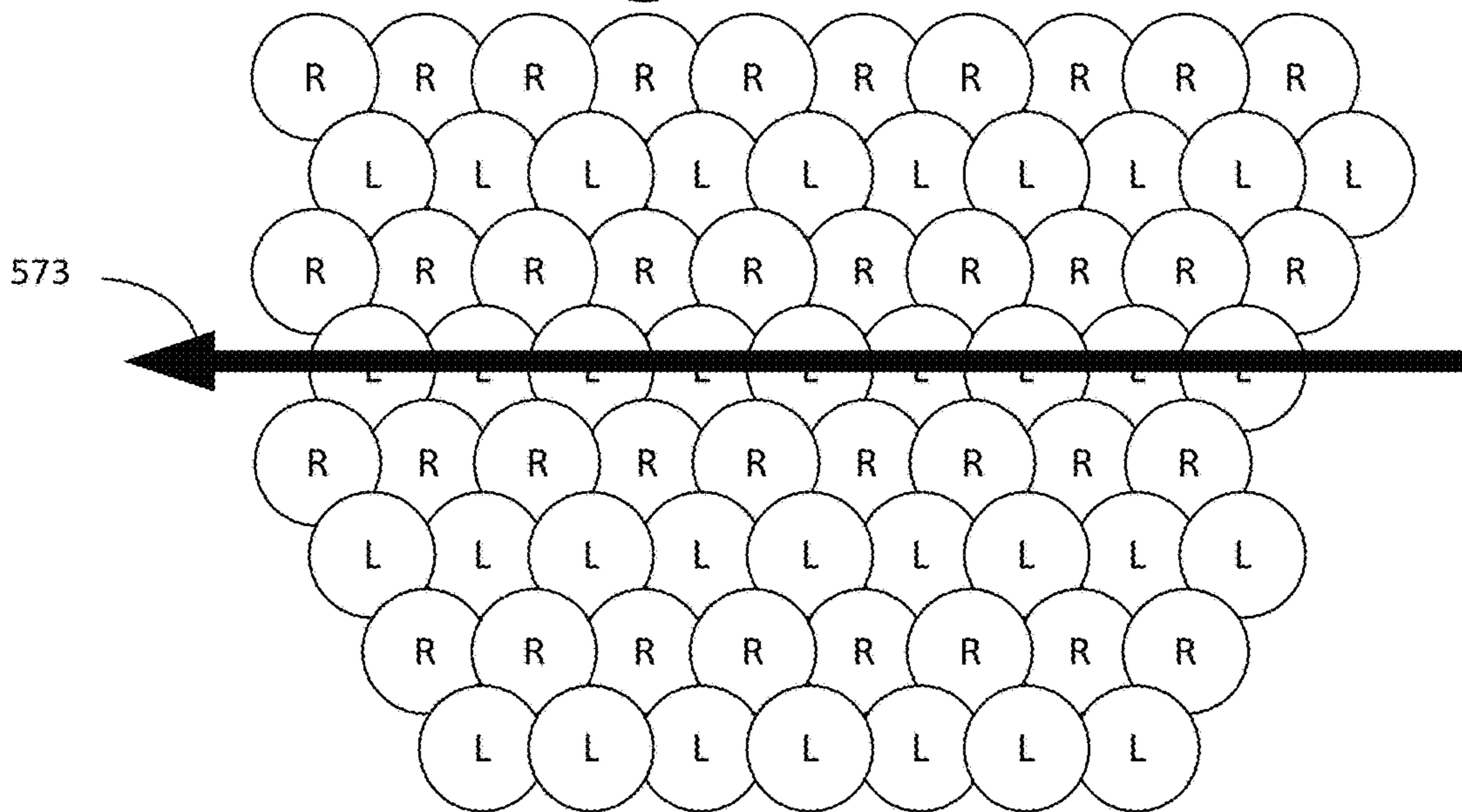
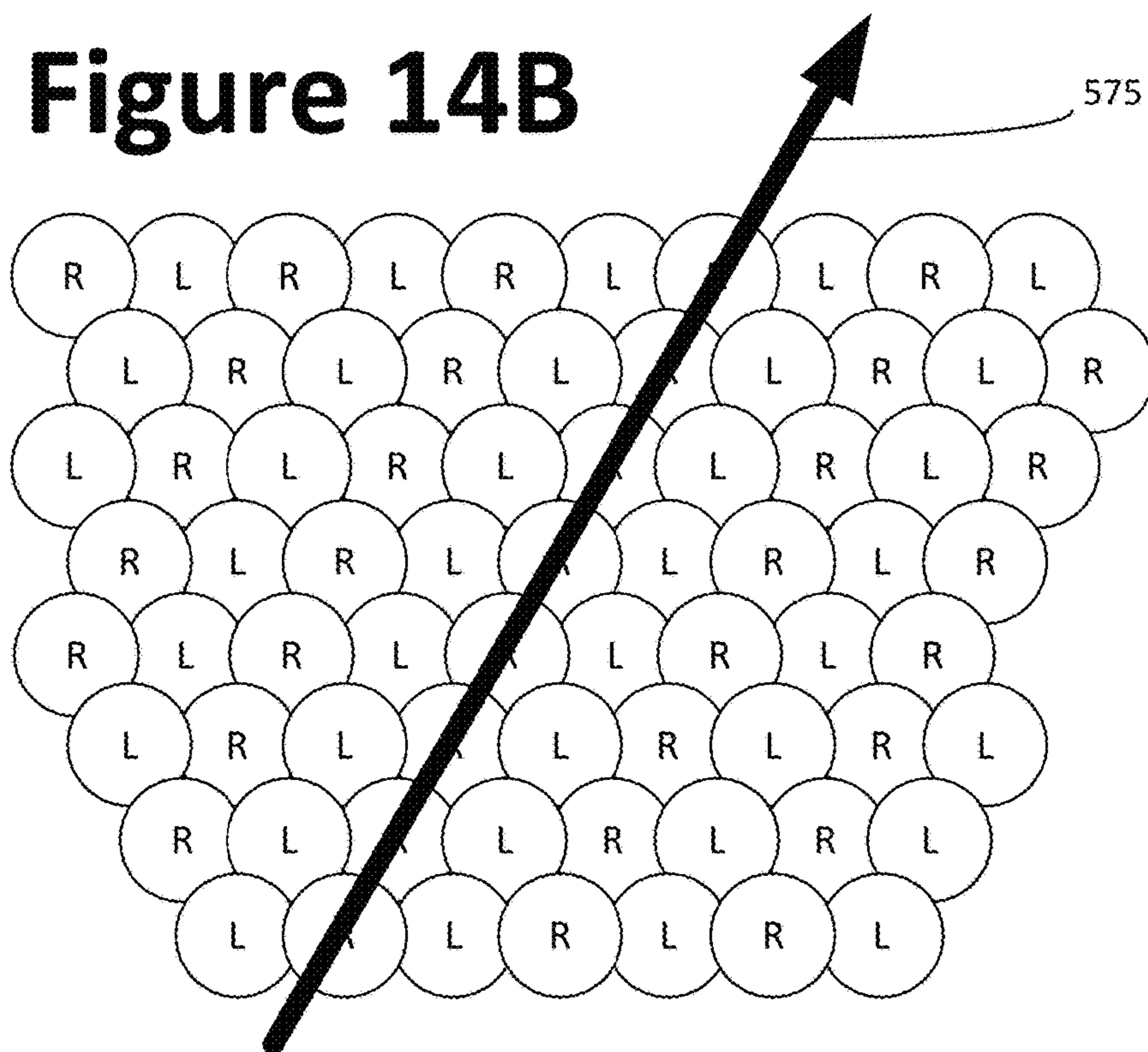

Figure 14B



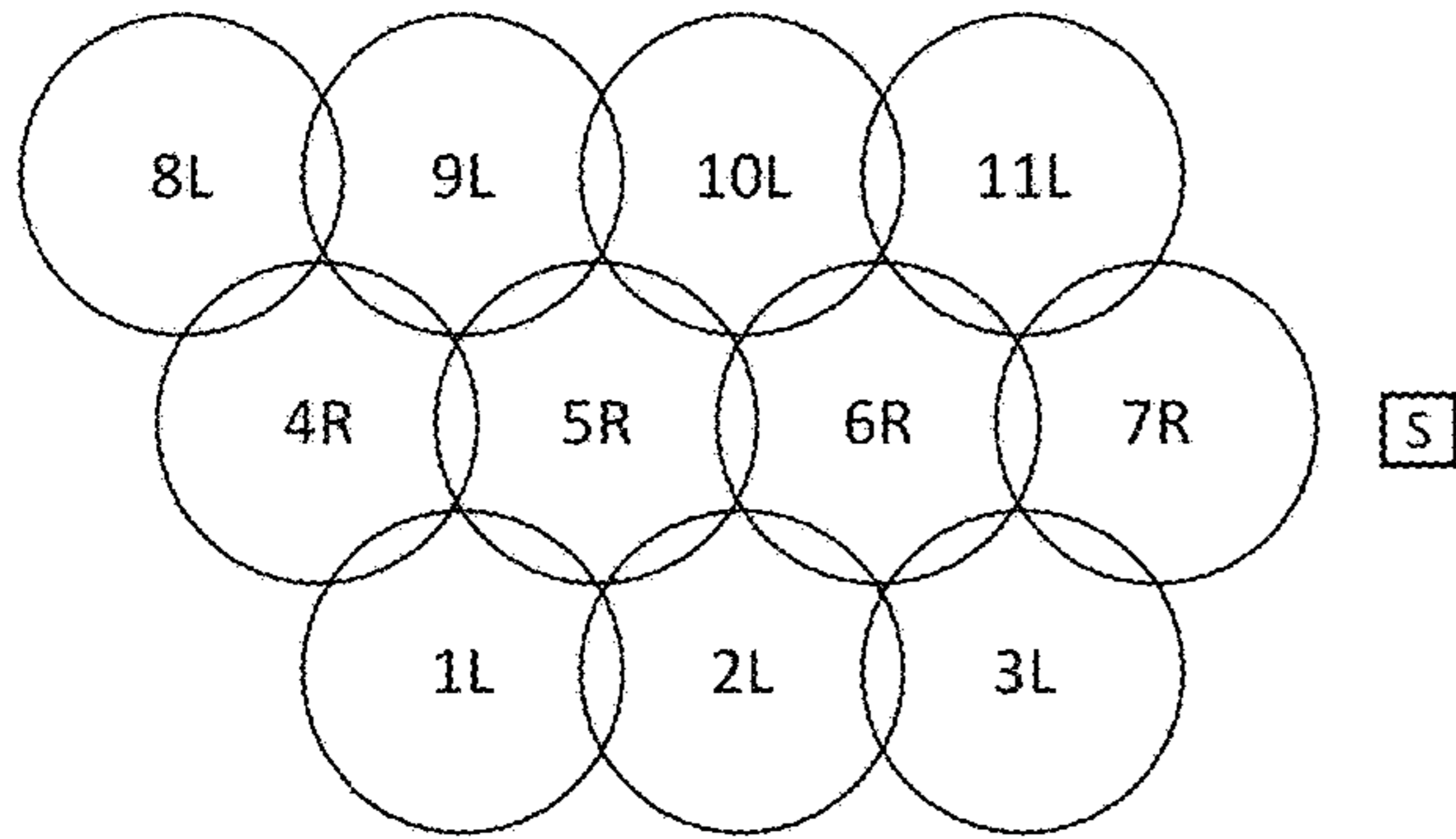

Figure 15A

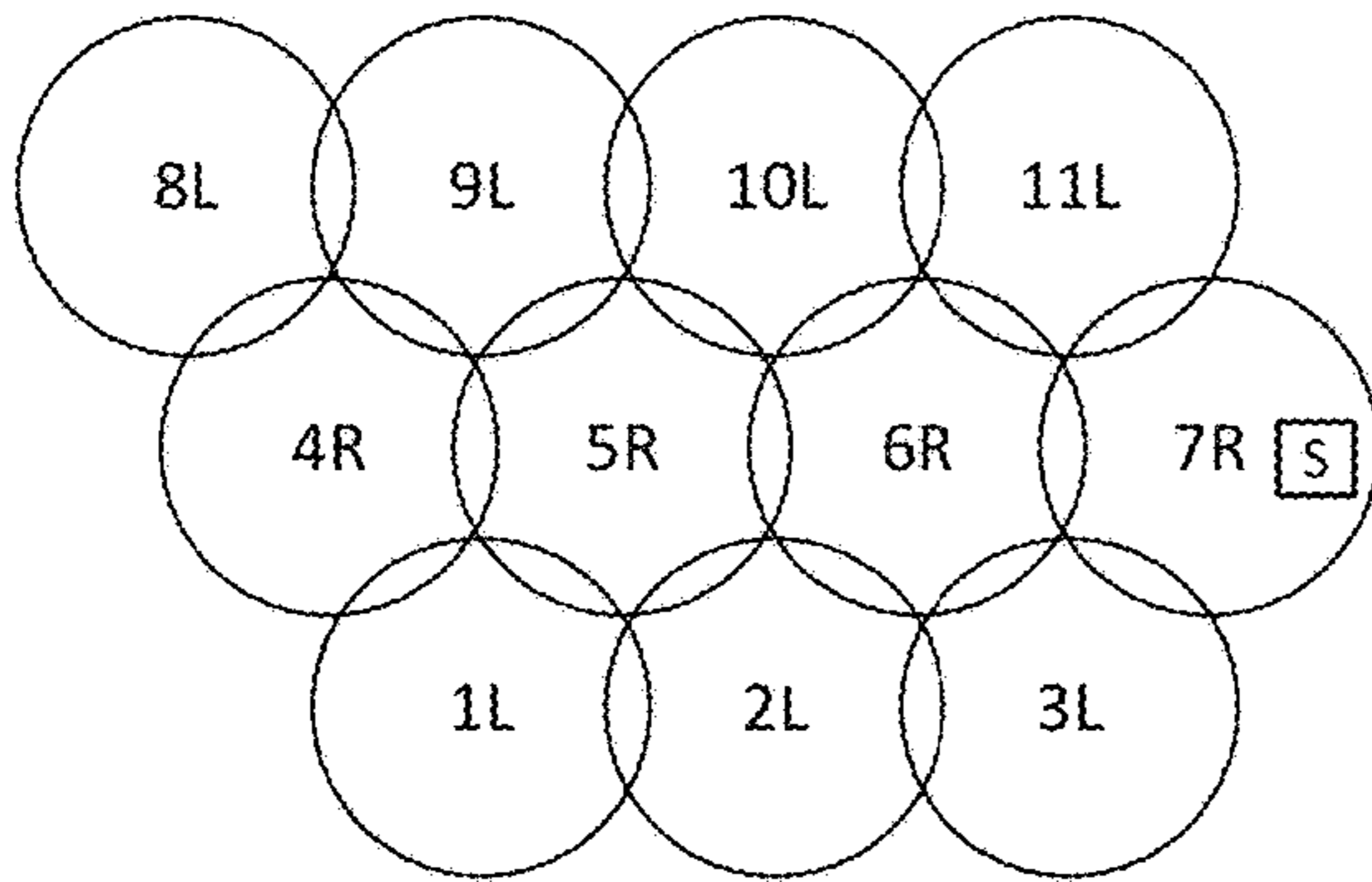

Figure 15B

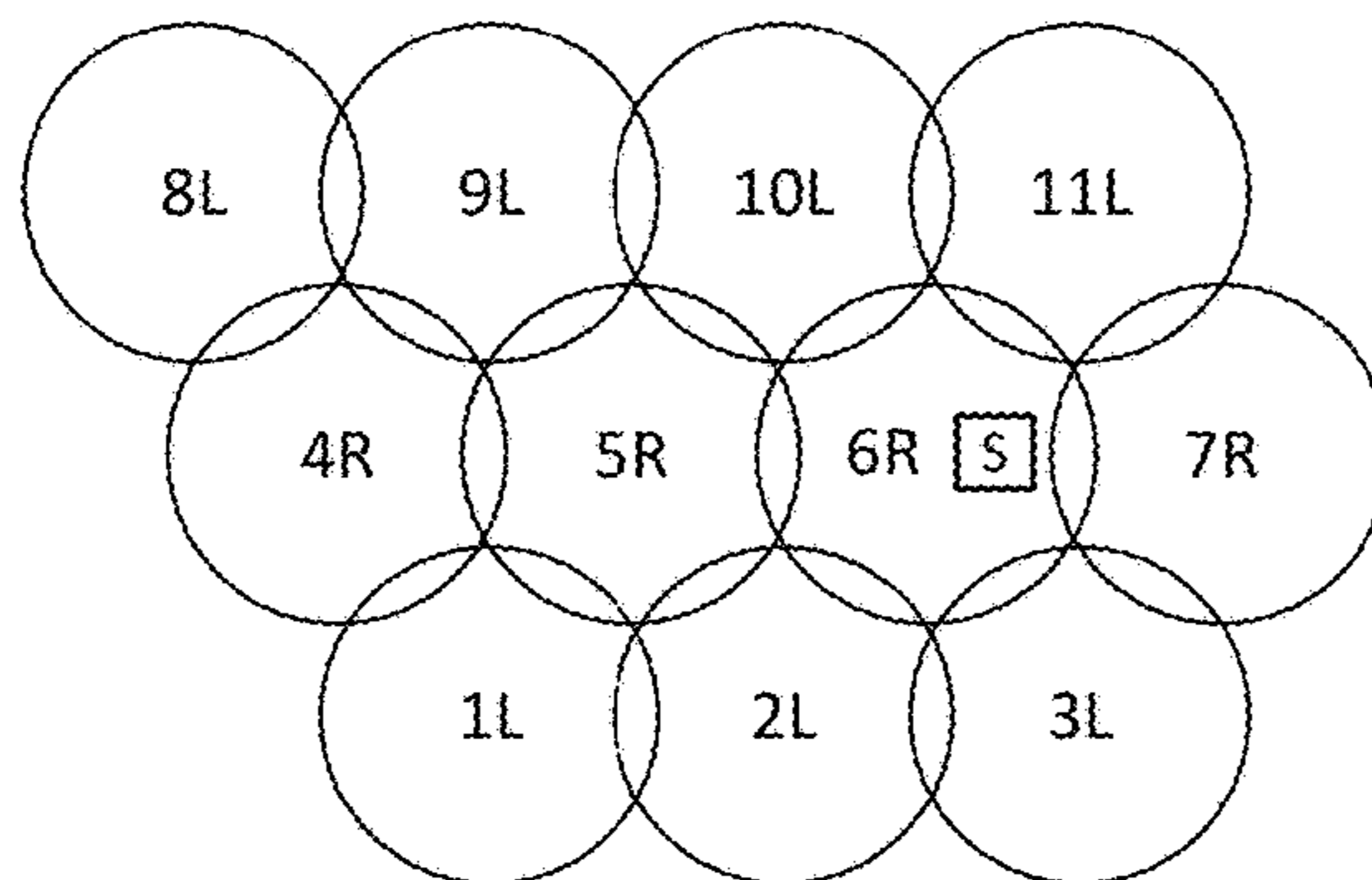

Figure 15C

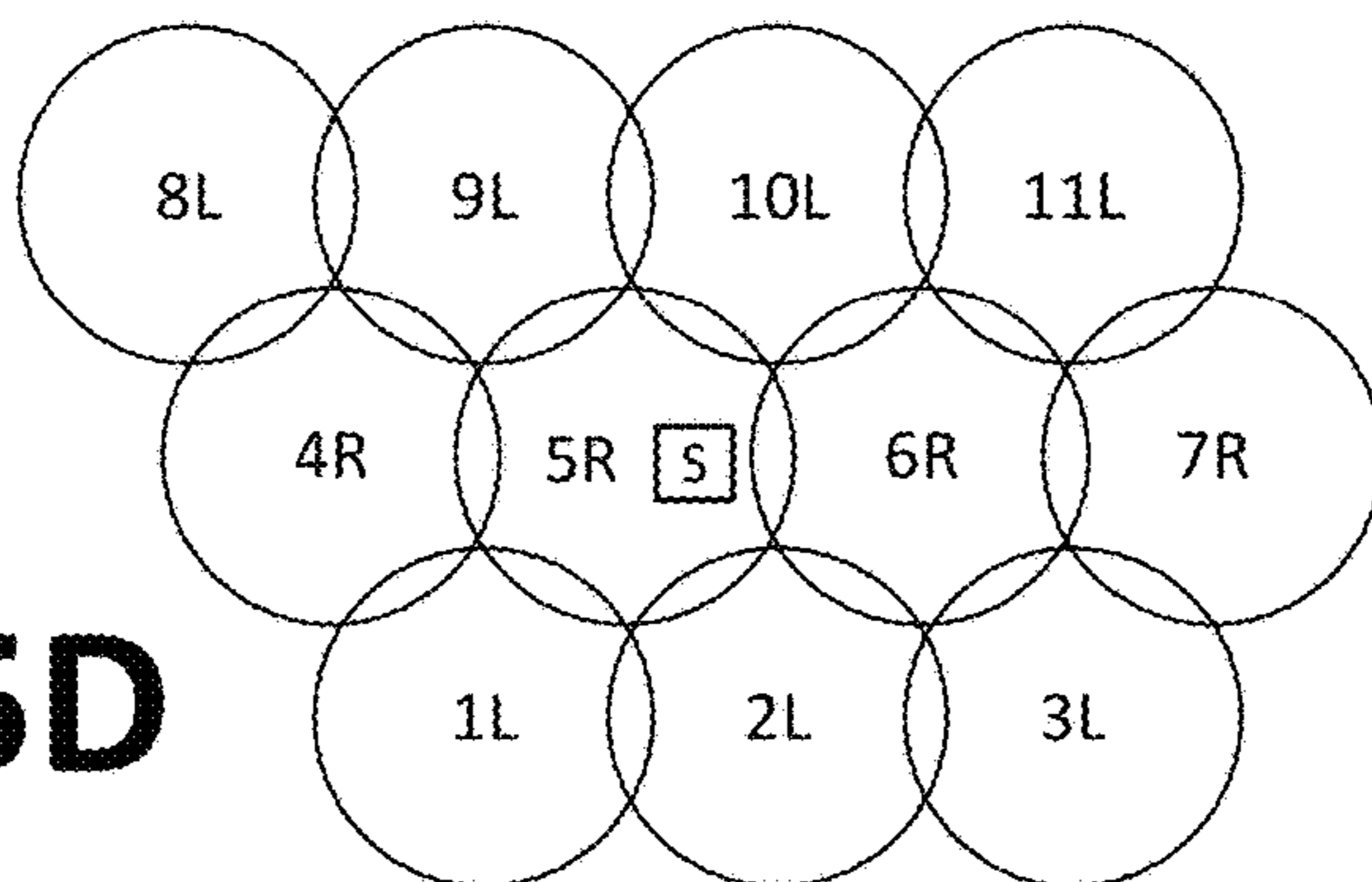

Figure 15D

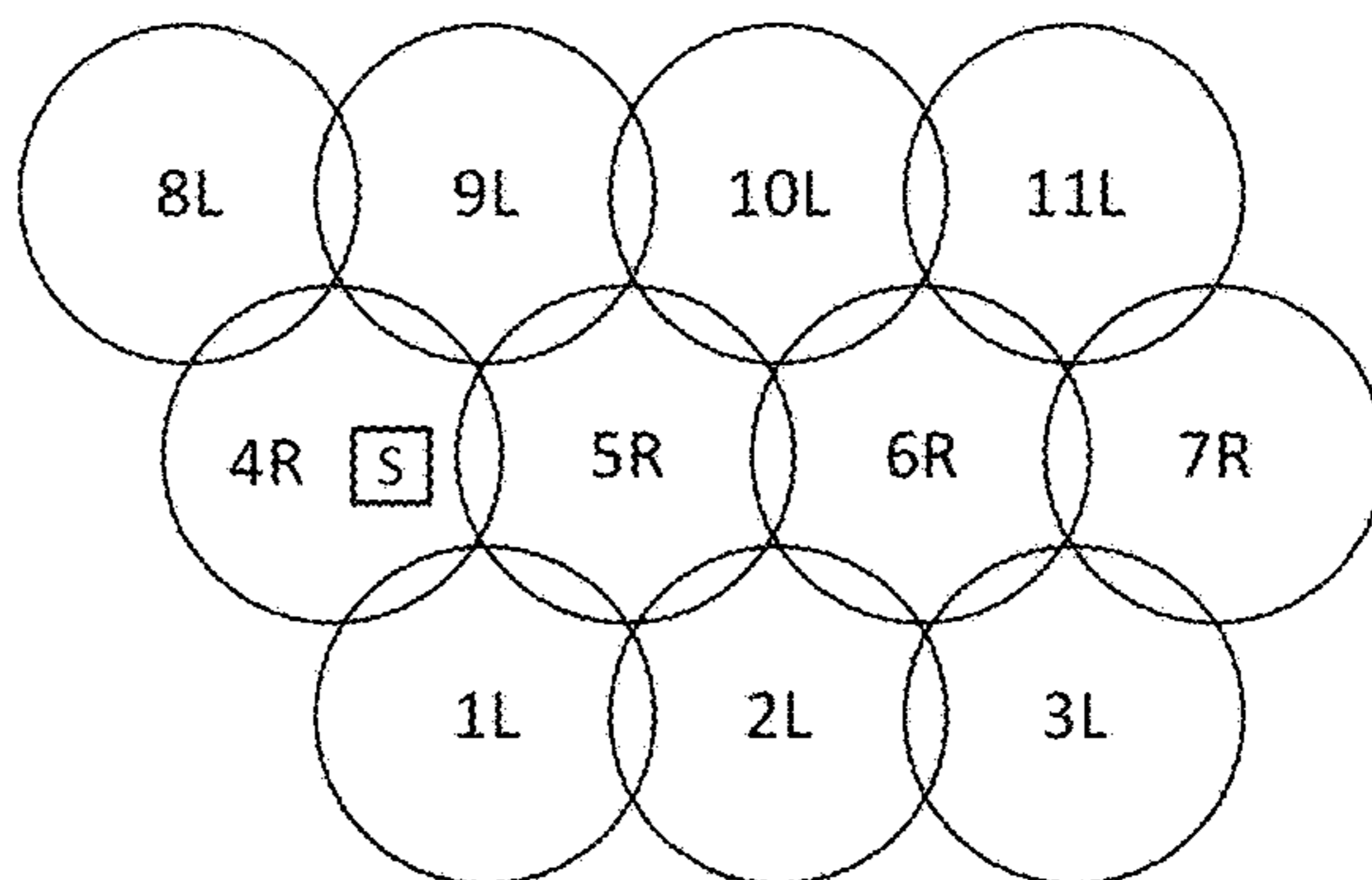

Figure 15E

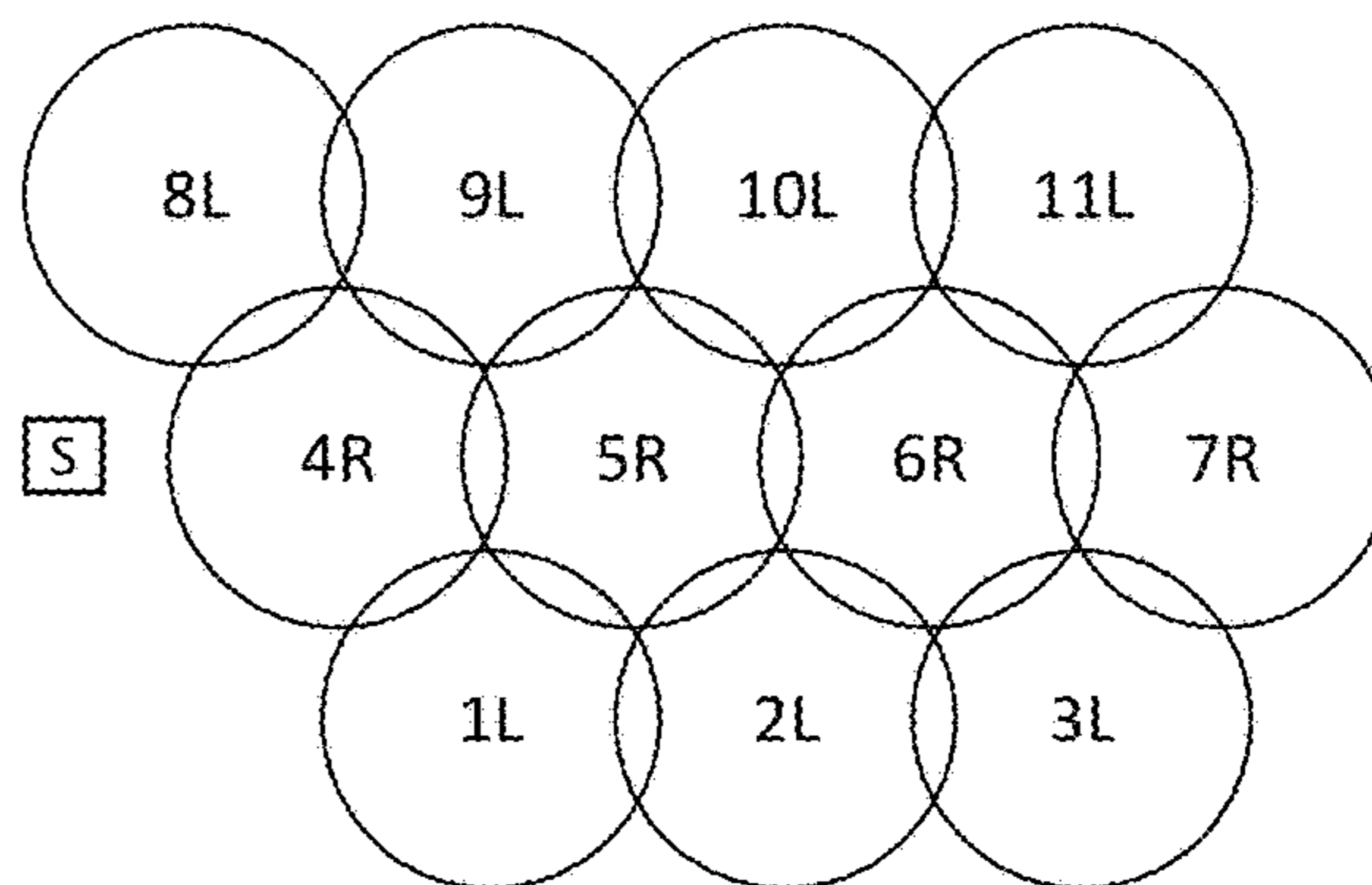

Figure 15F

Figure 15G

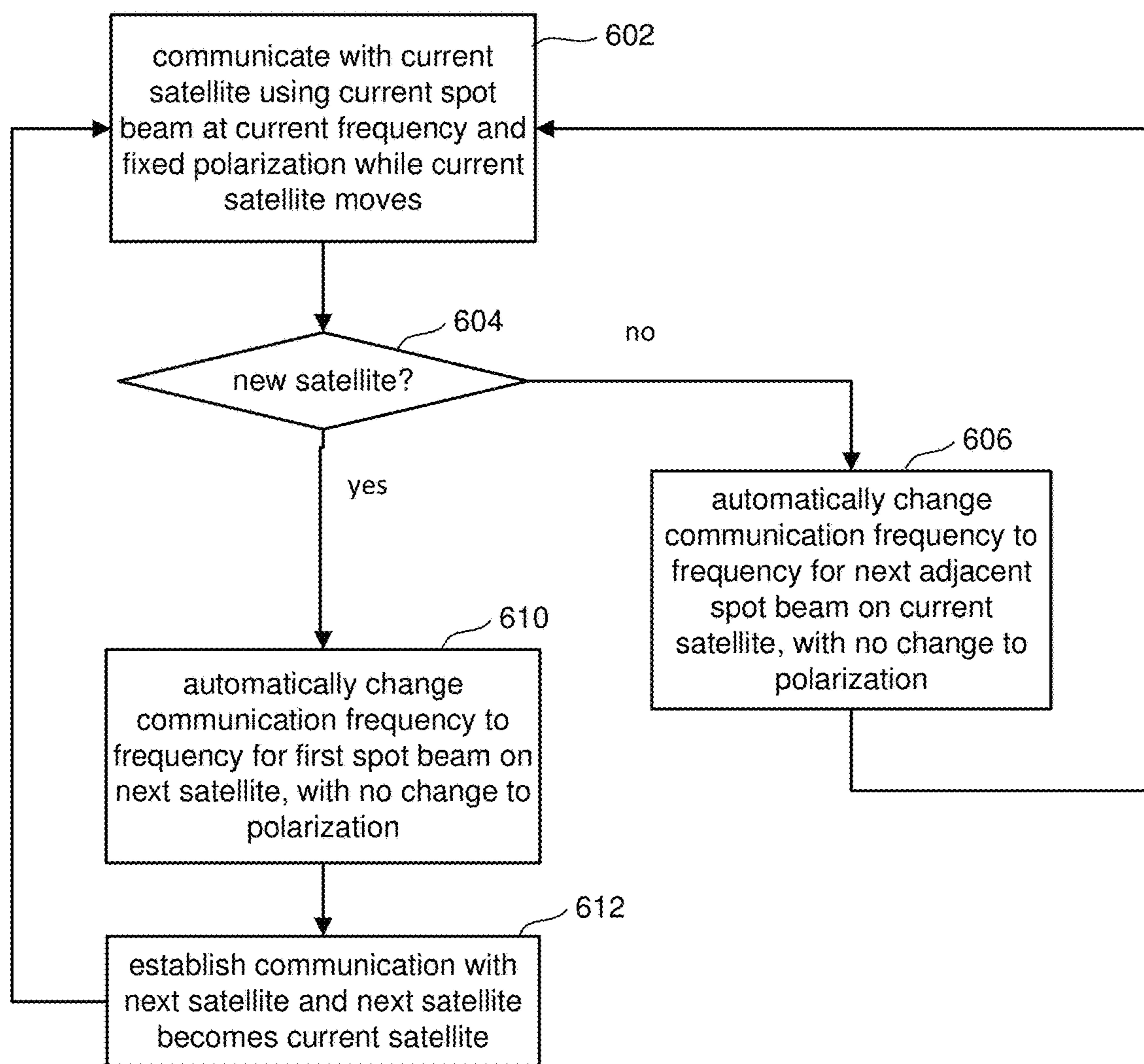
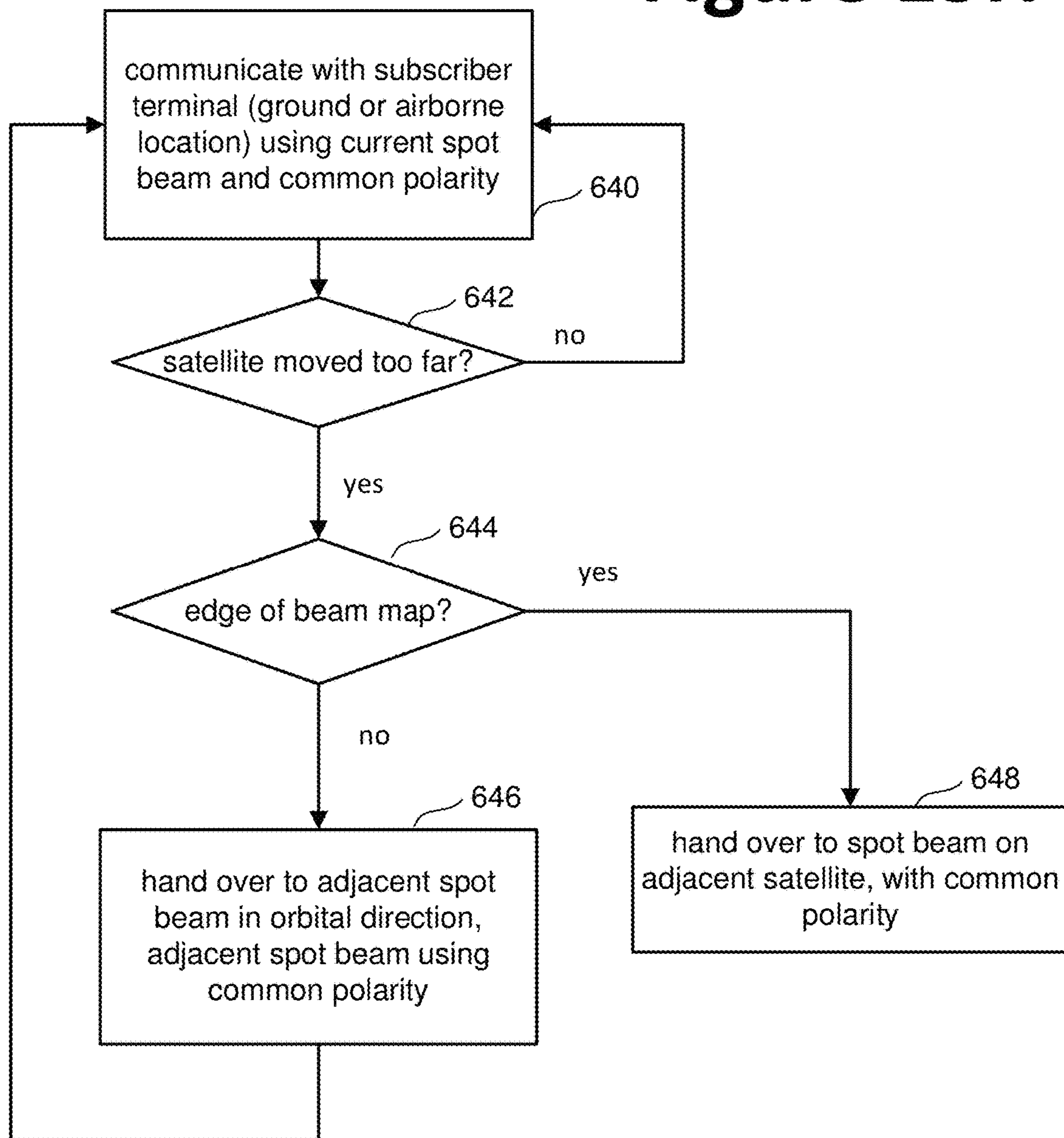

Figure 15H



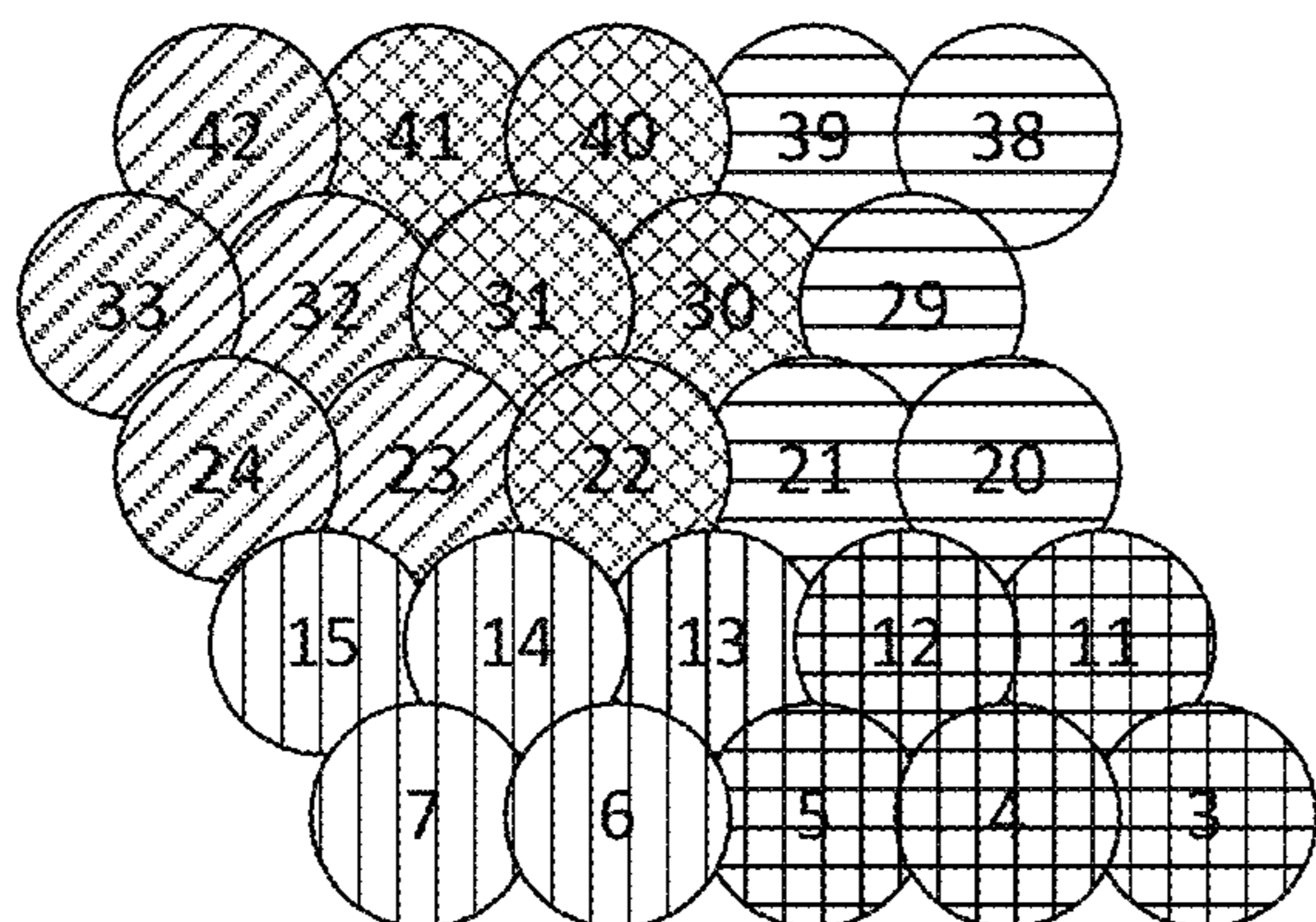

Figure 16A

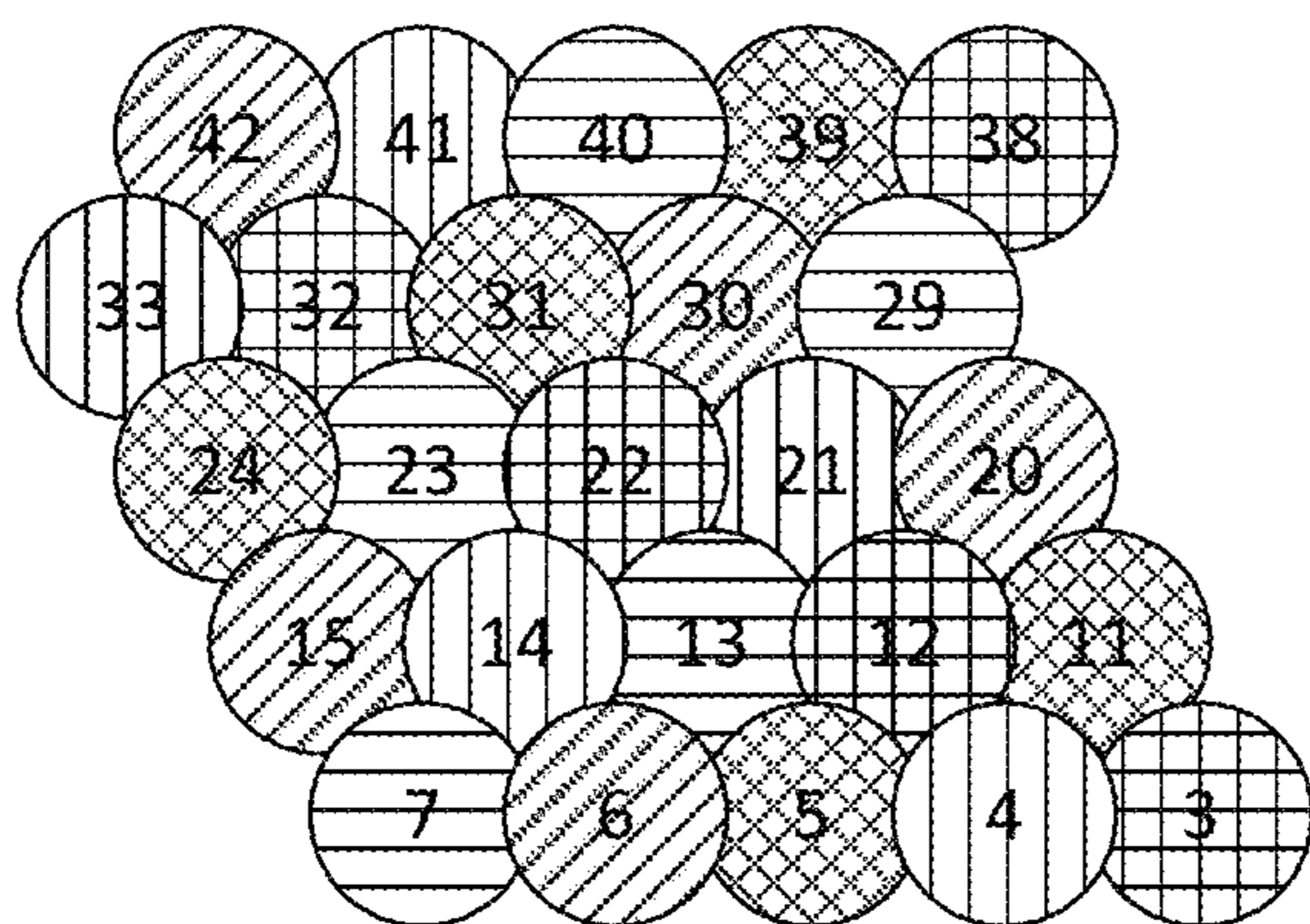

Figure 16B

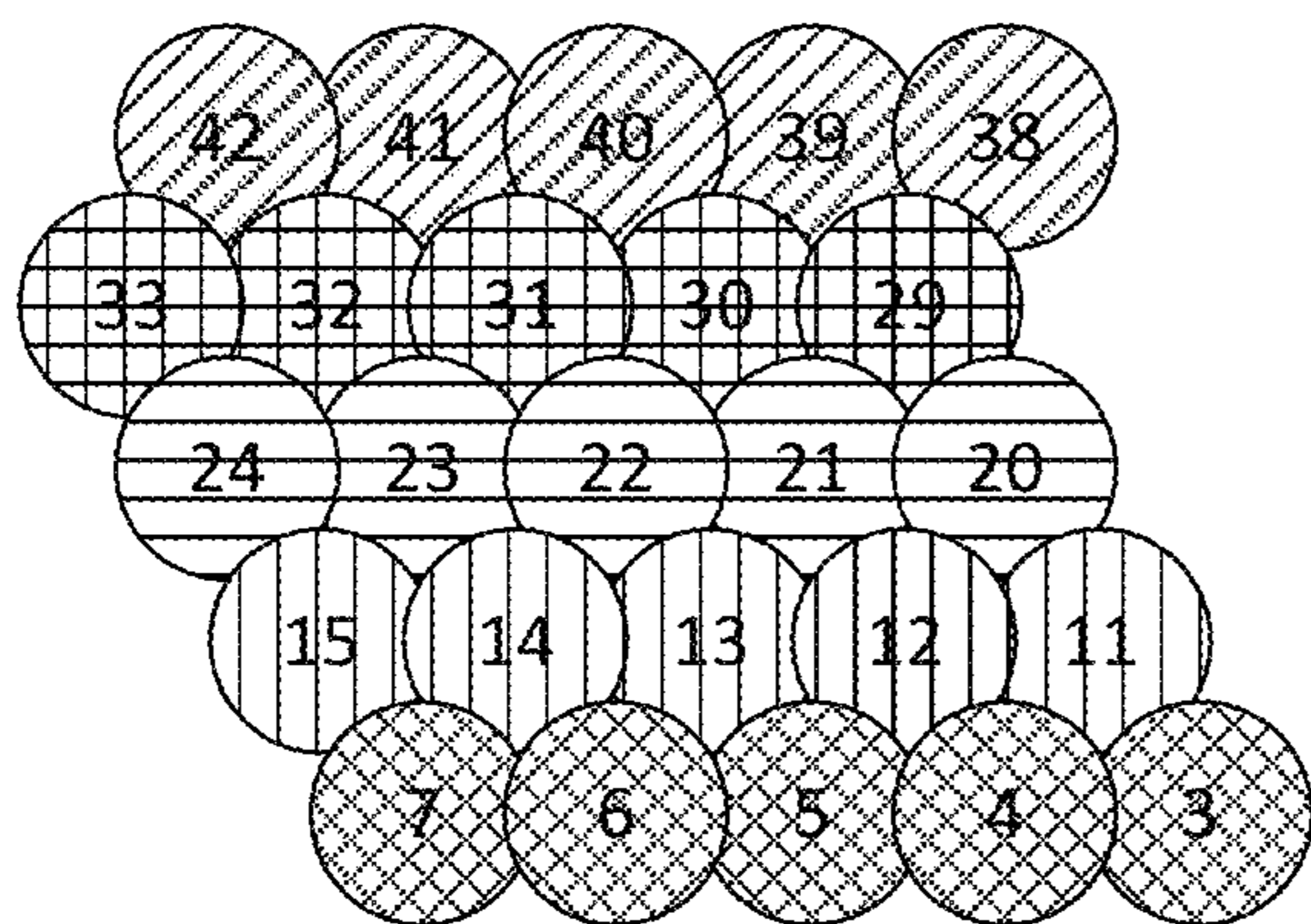

Figure 16C

→
orbital direction

Figure 17A

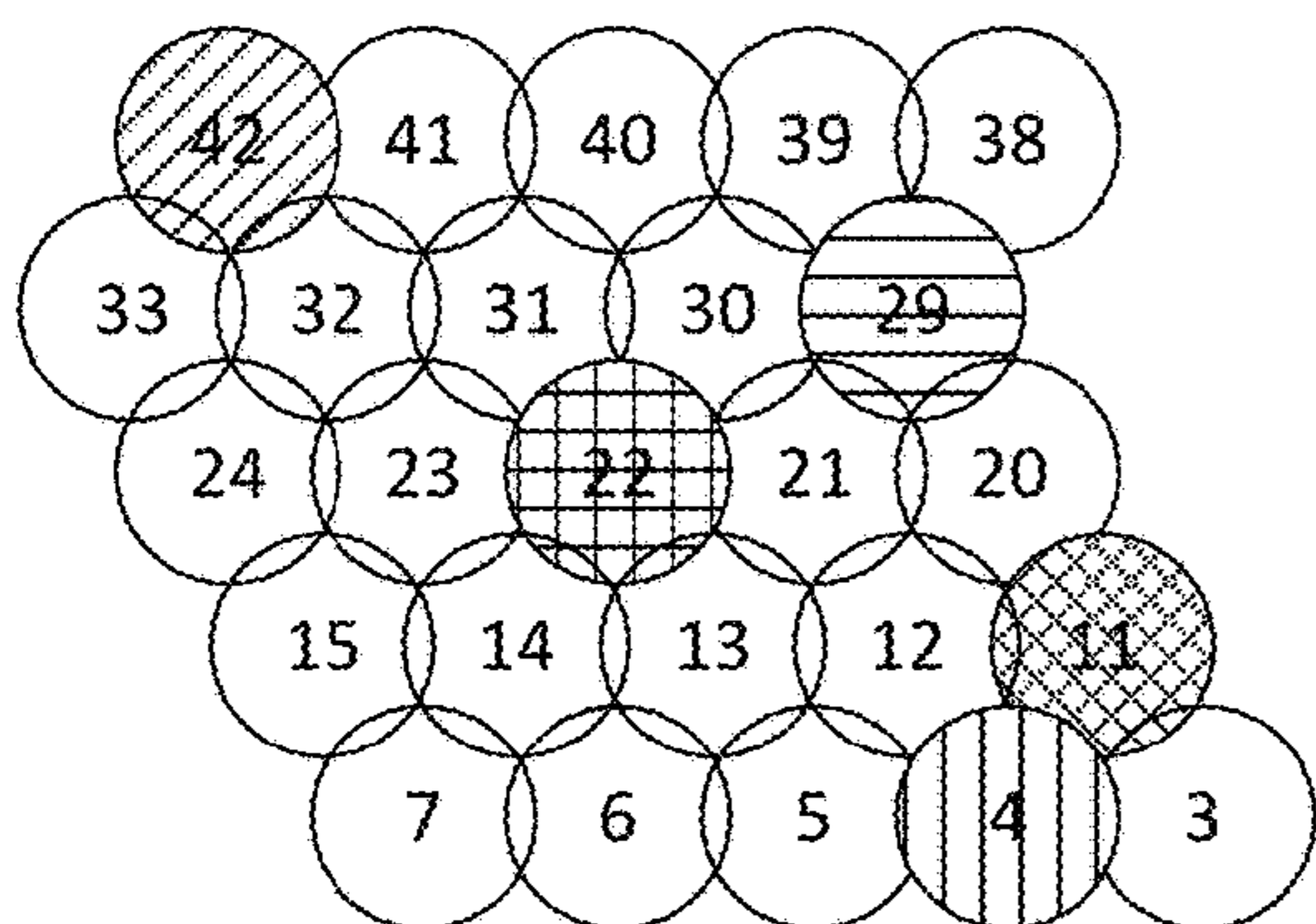

Figure 17B

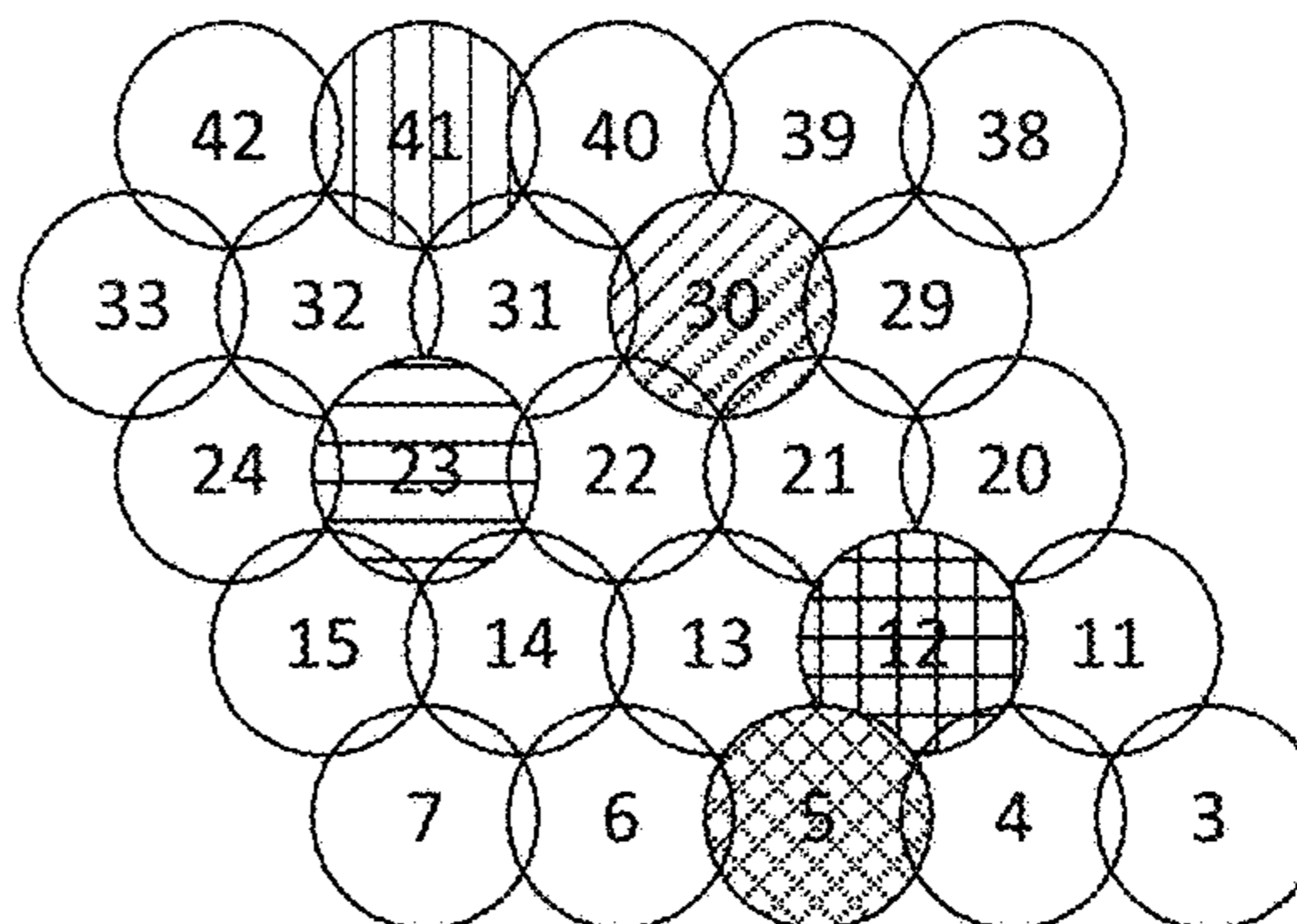

Figure 17C

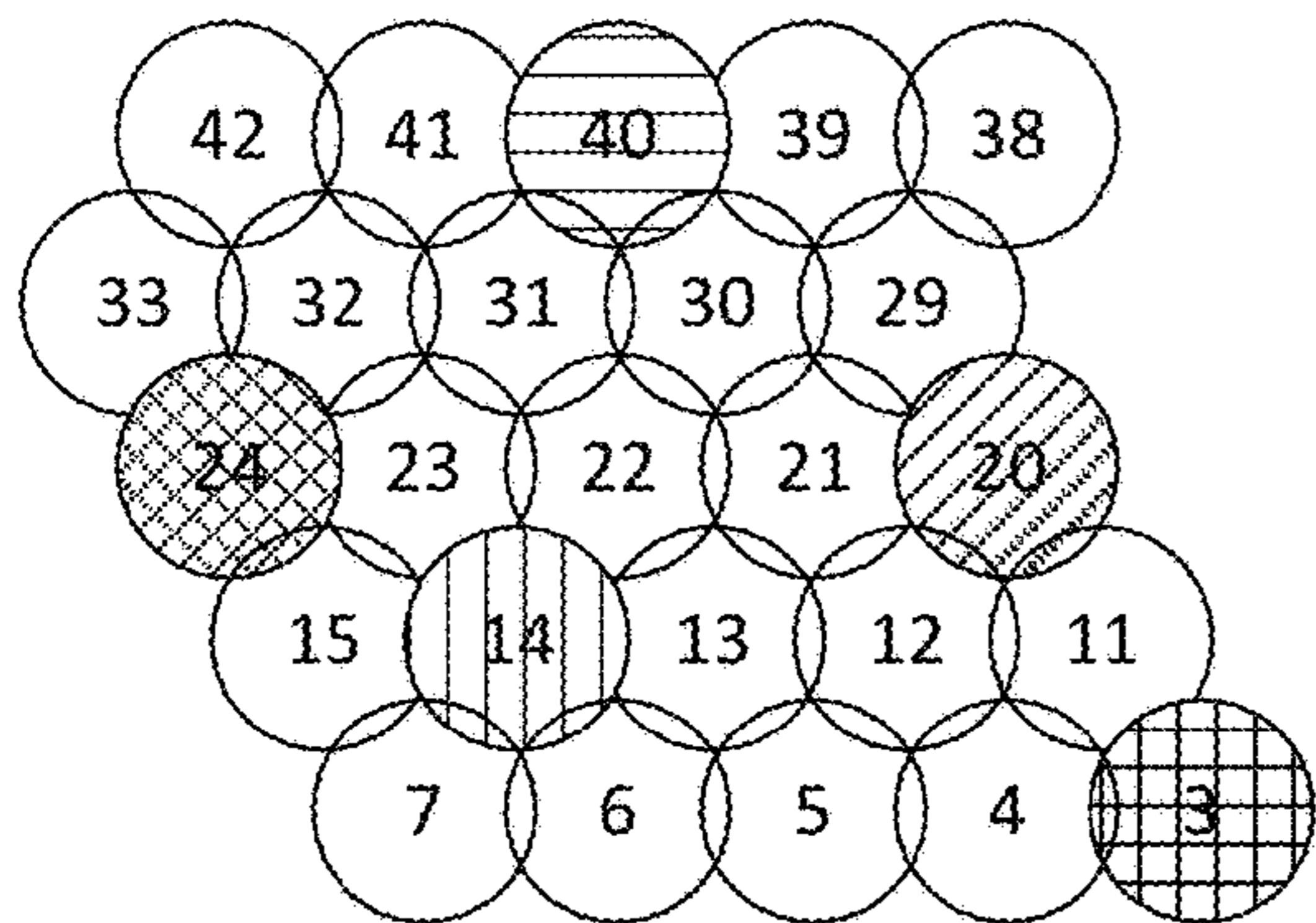

Figure 17D

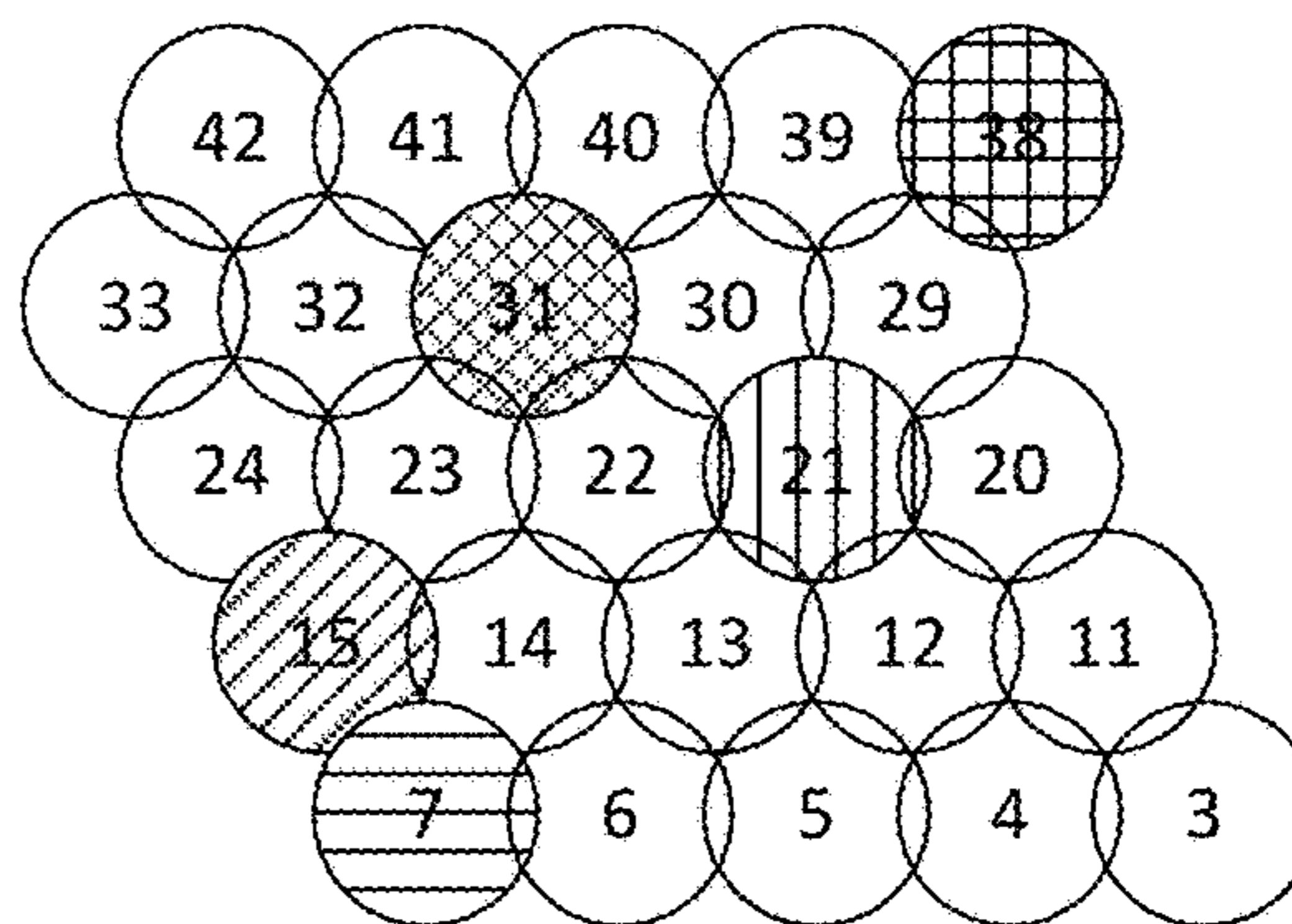

Figure 17E

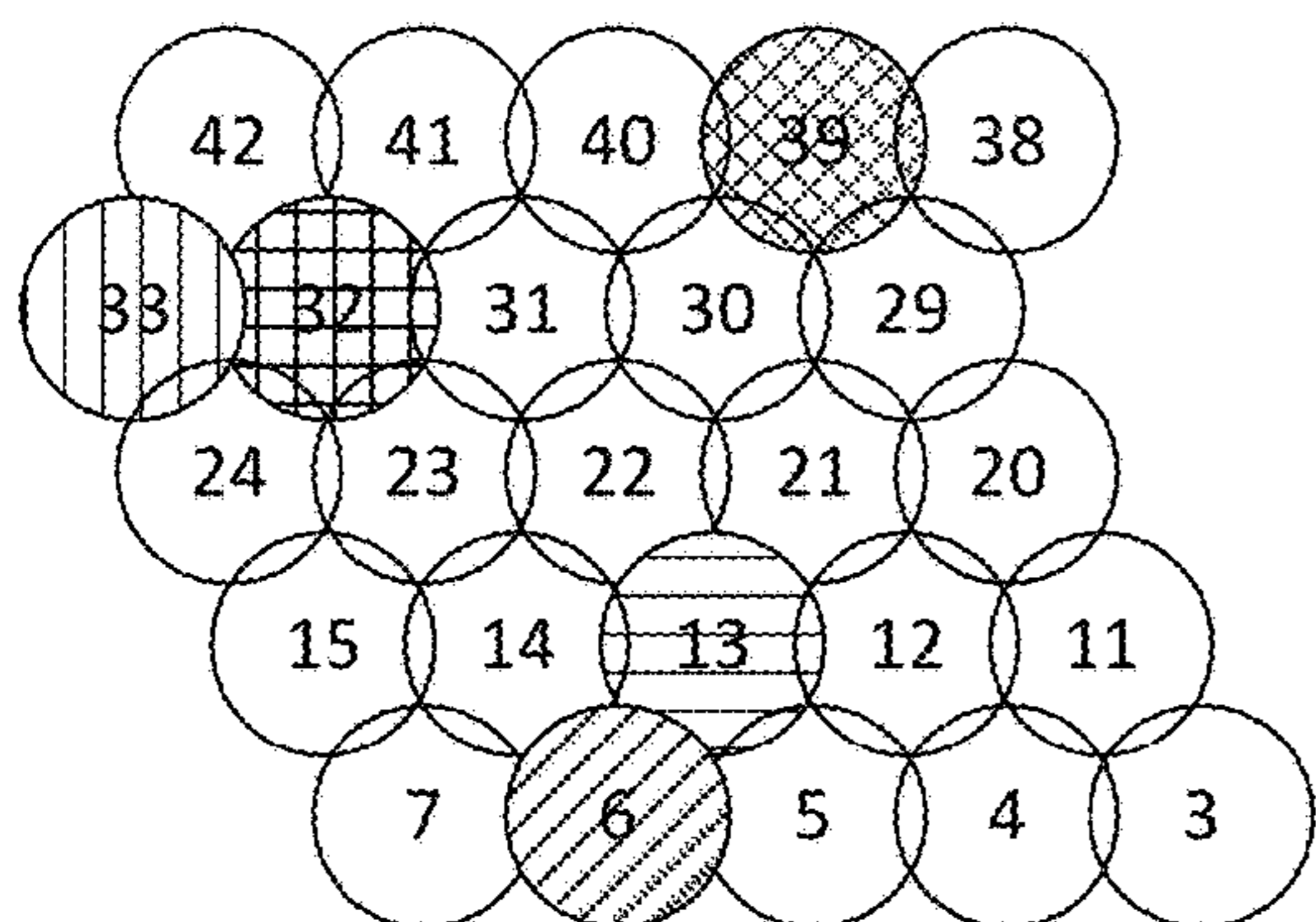

Figure 18

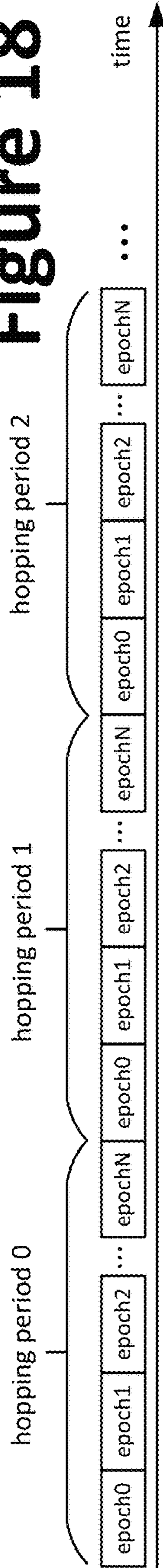

Figure 19

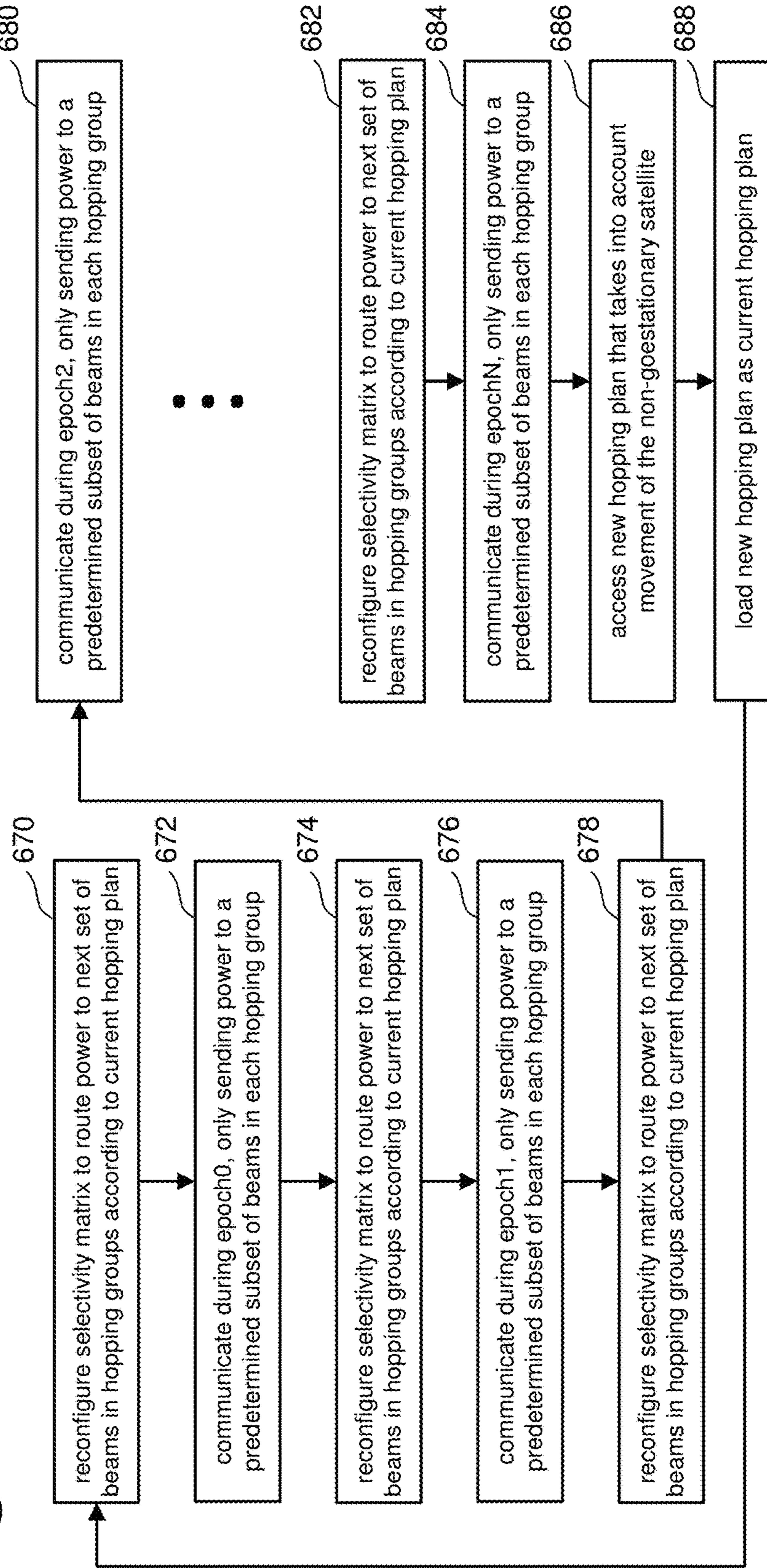
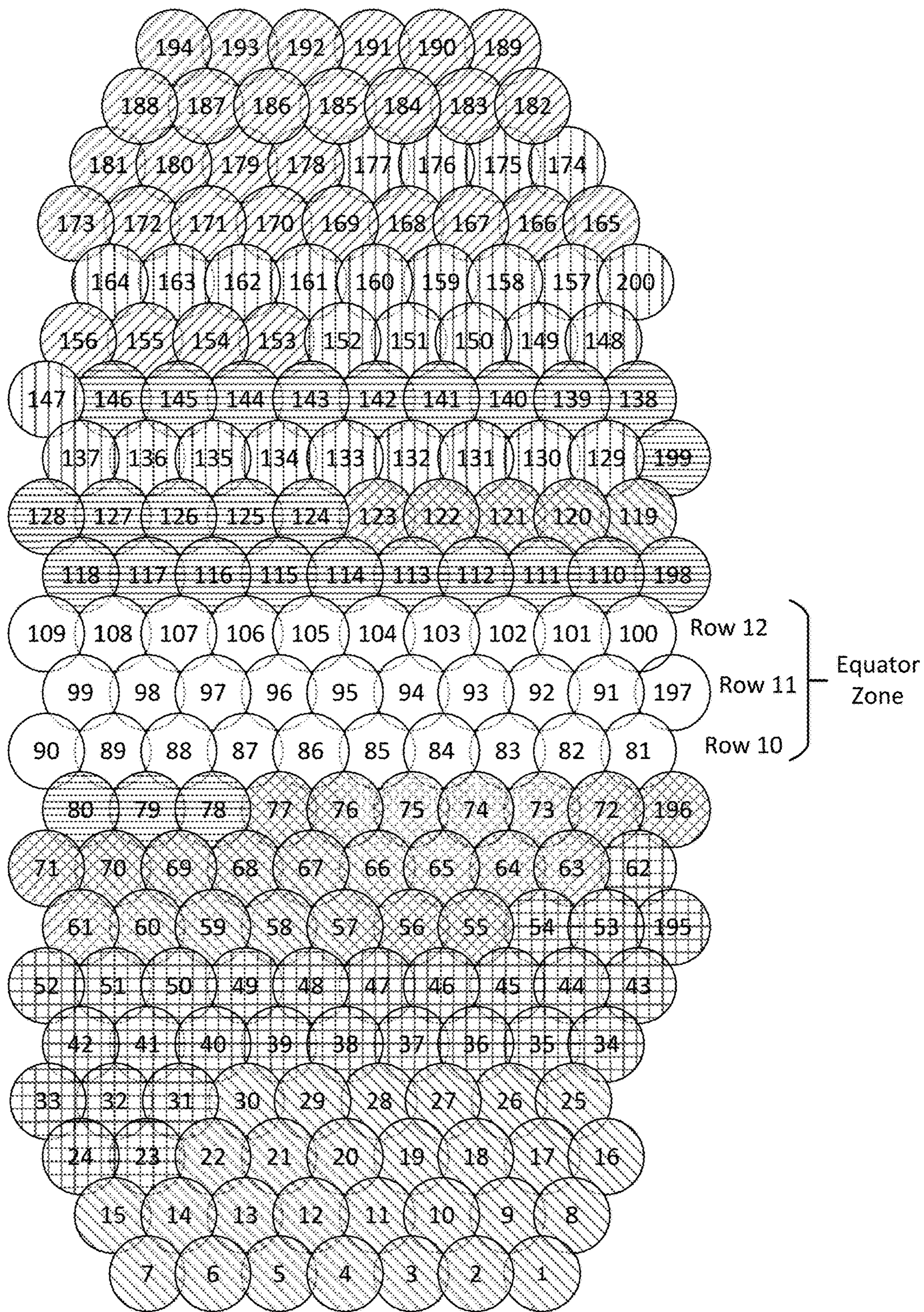
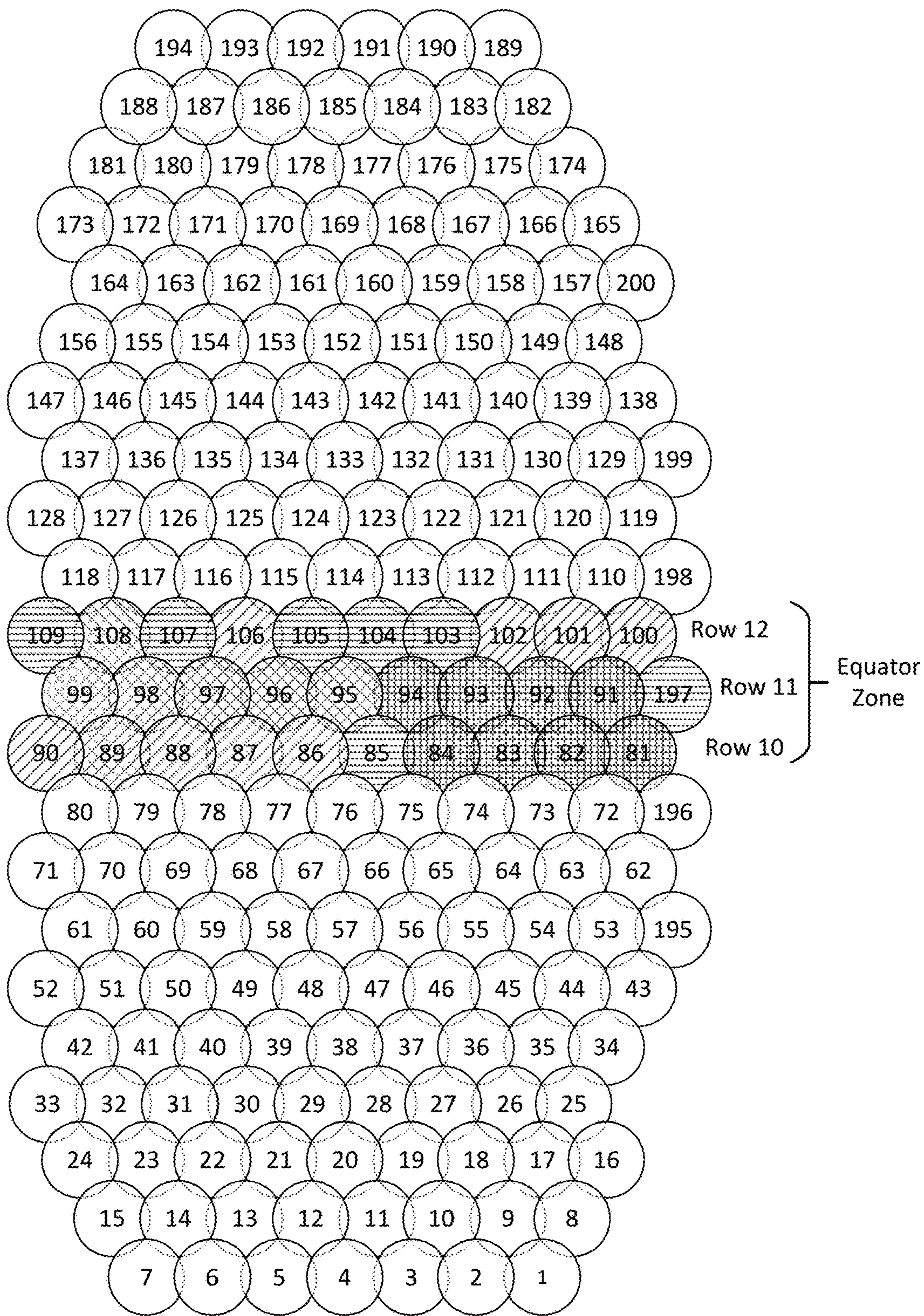

Figure 20A



Field of Regard

Figure 20B



Field of Regard

HG1	1	23	55	78	129	153	189
HG2	2	24	56	79	130	154	190
HG3	3	31	57	80	131	155	-
HG4	4	32	58	198	132	156	-
HG5	5	33	59	110	133	165	-
HG6	6	34	60	111	134	166	-
HG7	7	35	61	112	135	167	-
HG8	8	36	63	113	136	168	-
HG9	9	37	64	114	137	169	-
HG10	10	38	65	115	147	170	-
HG11	11	39	66	116	148	171	-
HG12	12	40	67	117	149	172	-
HG13	13	41	68	118	150	173	-
HG14	14	42	69	124	151	178	-
HG15	15	43	70	125	152	179	-
HG16	16	44	71	126	200	180	-
HG17	17	45	72	127	157	181	-
HG18	18	46	73	128	158	182	-
HG19	19	47	74	199	159	183	-
HG20	20	48	75	138	160	184	-
HG21	21	49	76	139	161	185	-
HG22	22	50	77	140	162	186	-
HG23	25	51	196	141	163	187	-
HG24	26	52	123	142	164	188	-
HG25	27	53	122	143	174	191	-
HG26	28	54	121	144	175	192	-
HG27	29	195	120	145	176	193	-
HG28	30	62	119	146	177	194	-

Figure 21

EHG1	91	99	106	85
EHG2	92	89	101	104
EHG3	93	97	90	103
EHG4	94	98	86	197
EHG5	81	95	100	107
EHG6	82	96	102	-
EHG7	83	108	88	105
EHG8	84	-	87	109

Figure 22

Figure 23

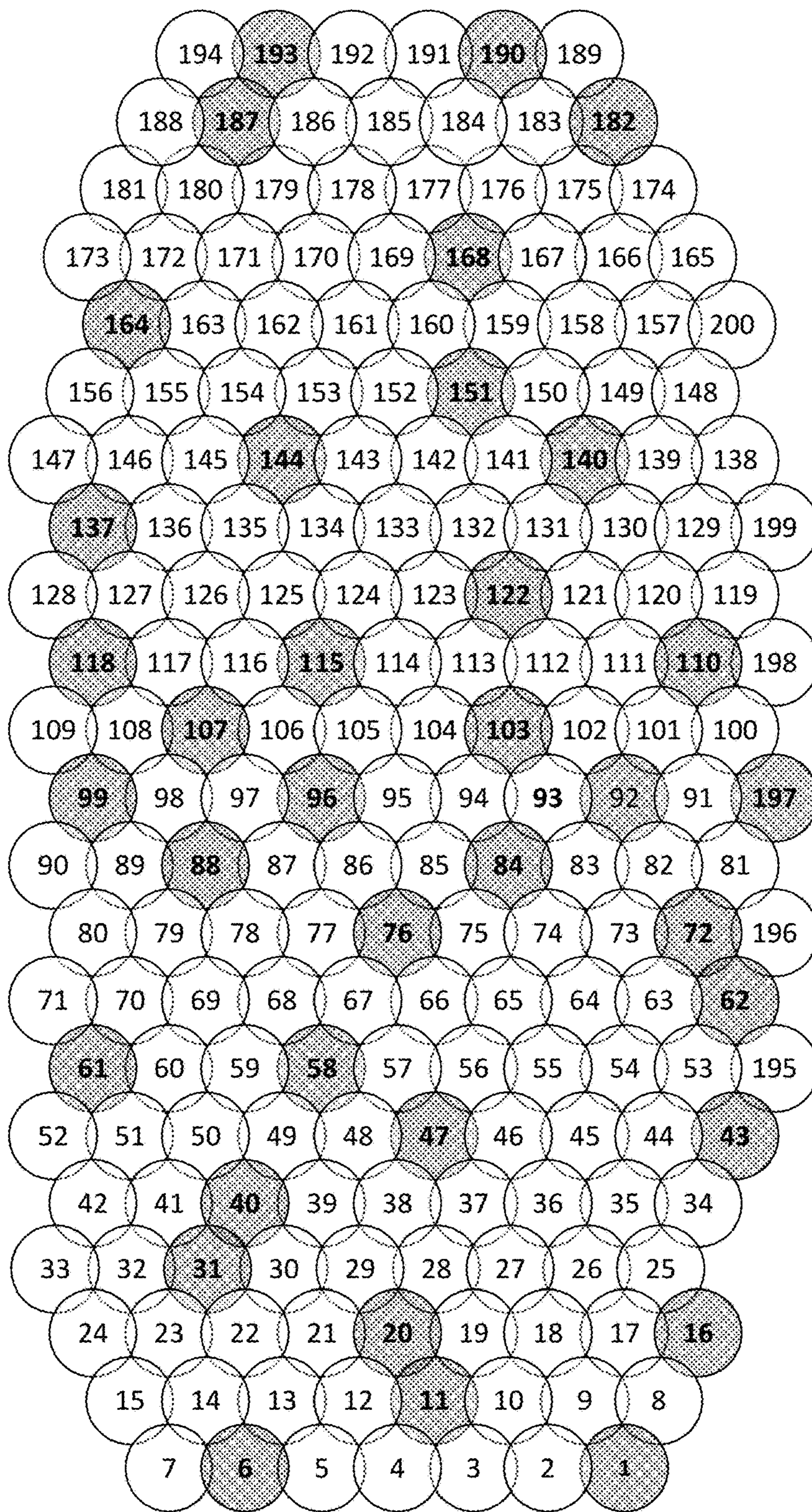

Field of Regard

Figure 24

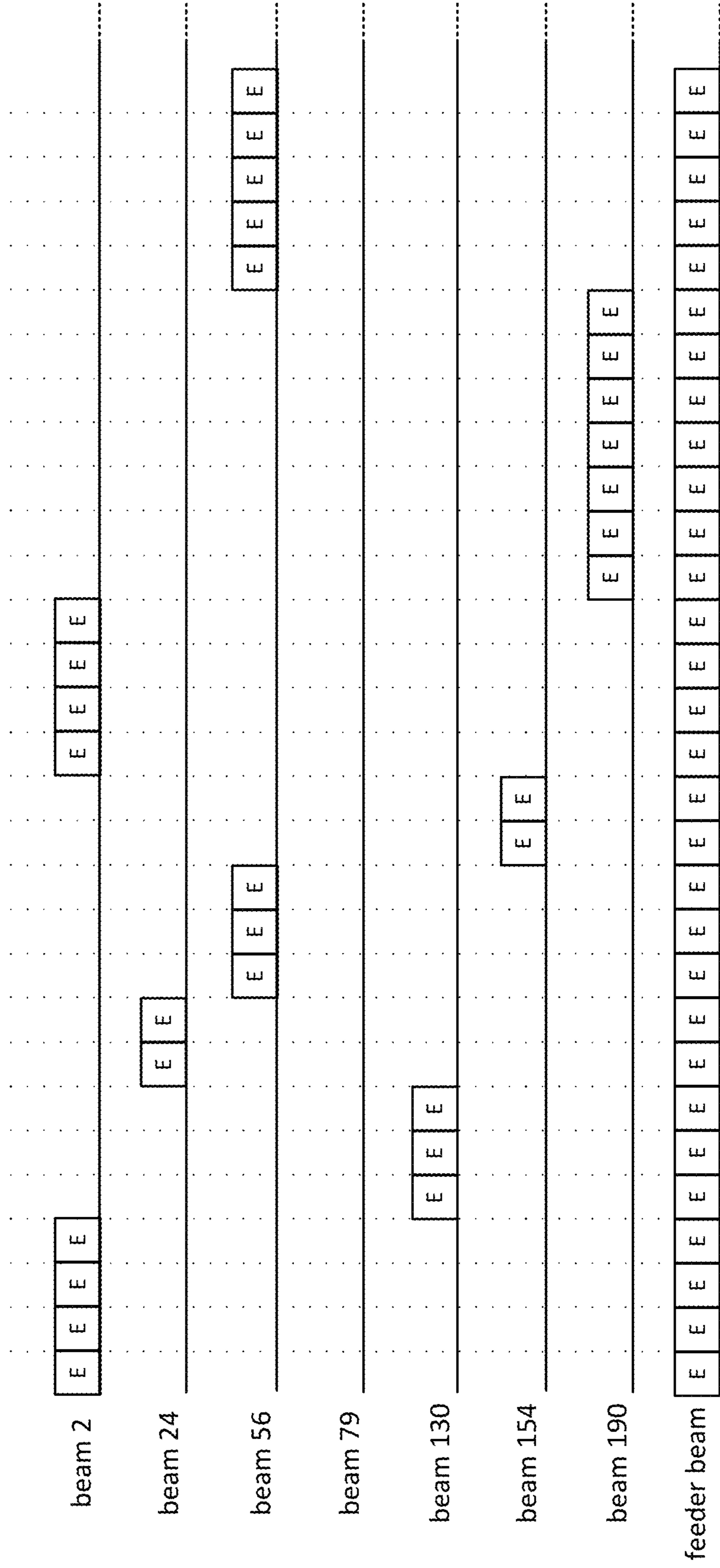

Figure 25

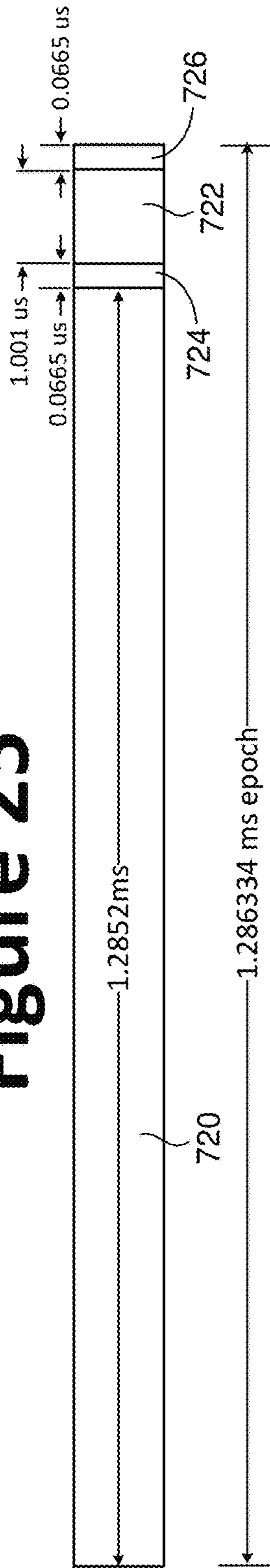

Figure 26

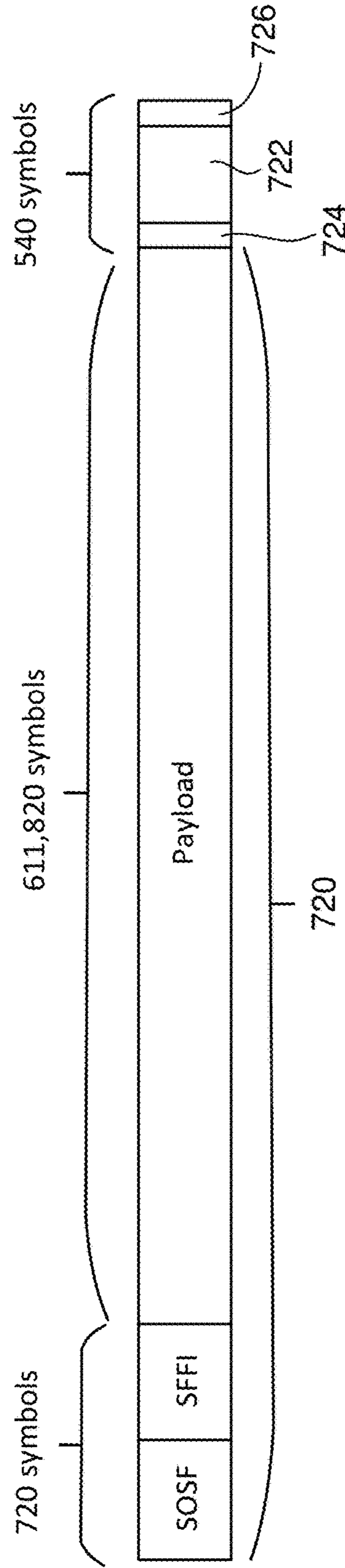

Figure 27

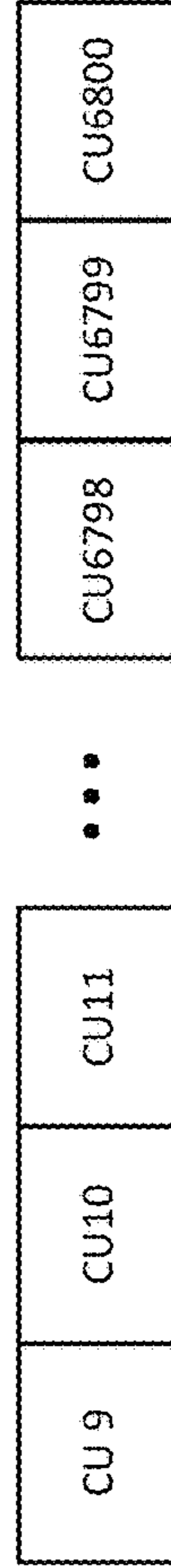

Figure 28

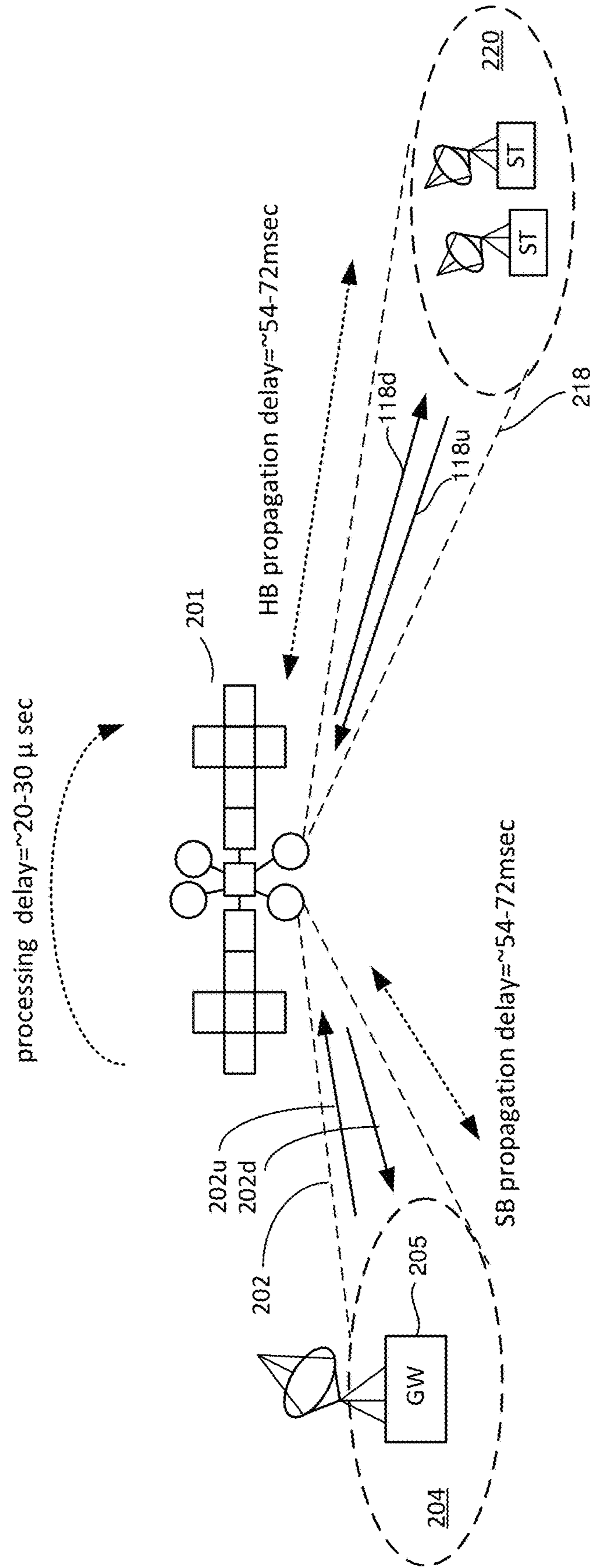

Figure 29

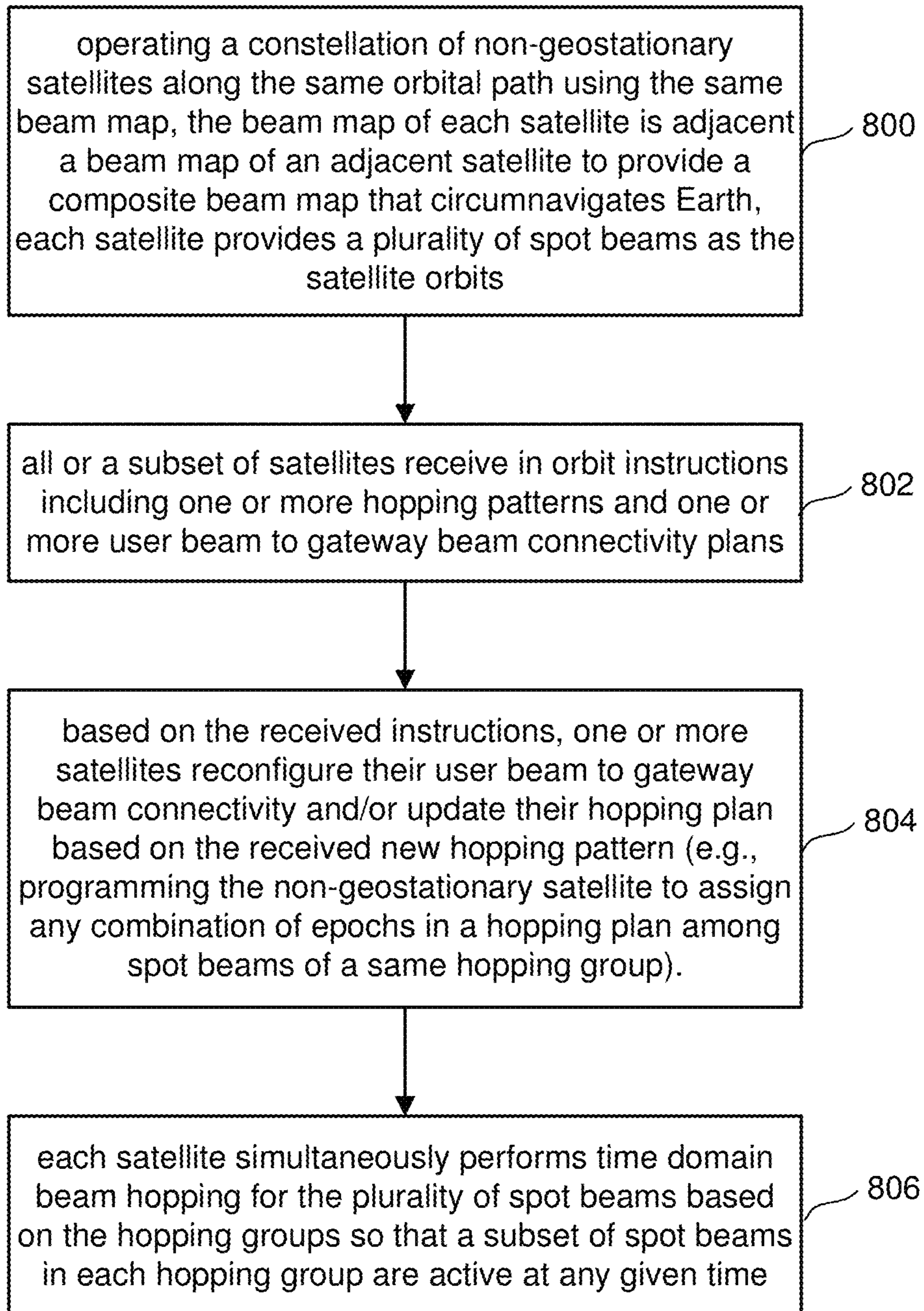

Figure 30

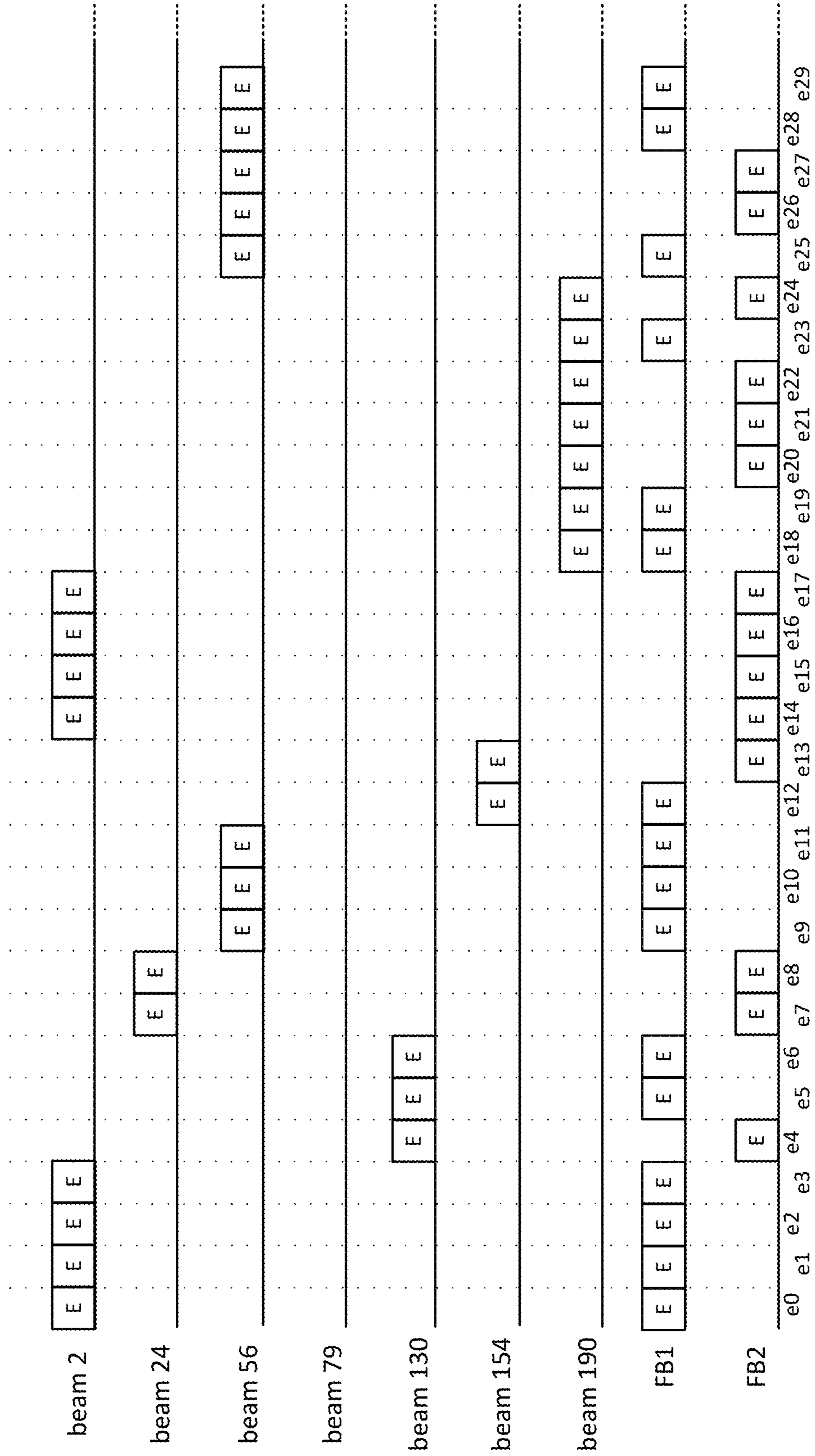

Figure 31

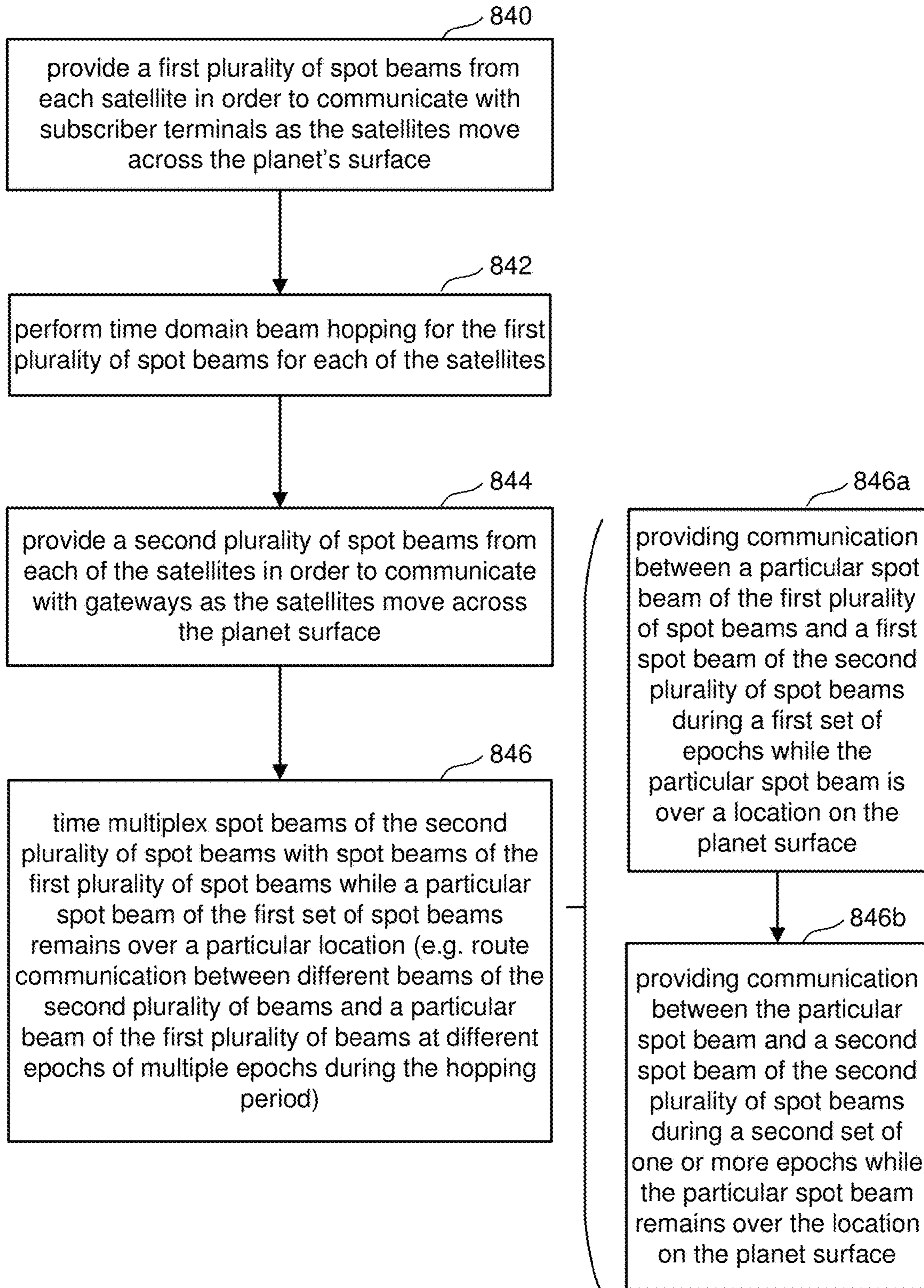
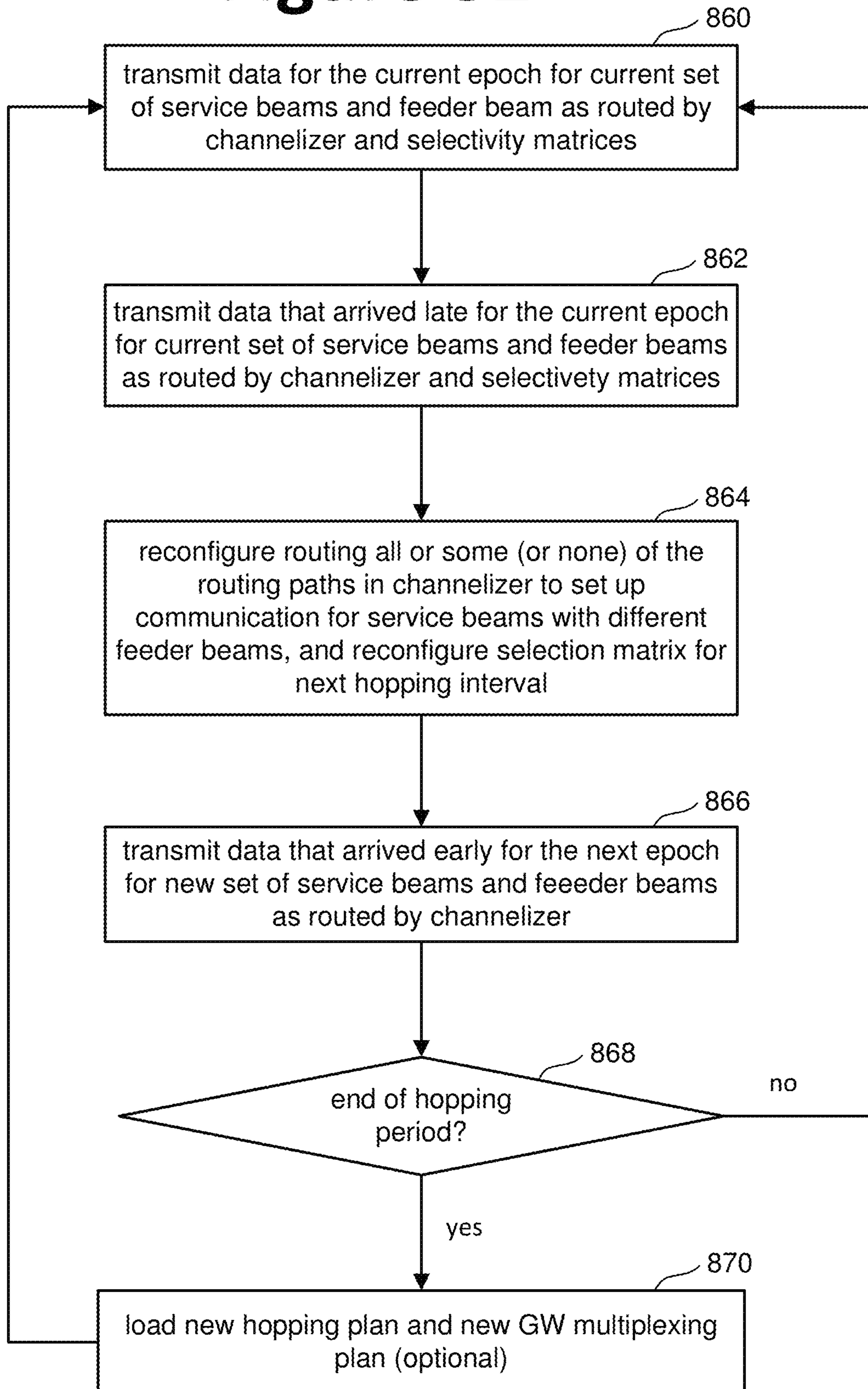

Figure 32



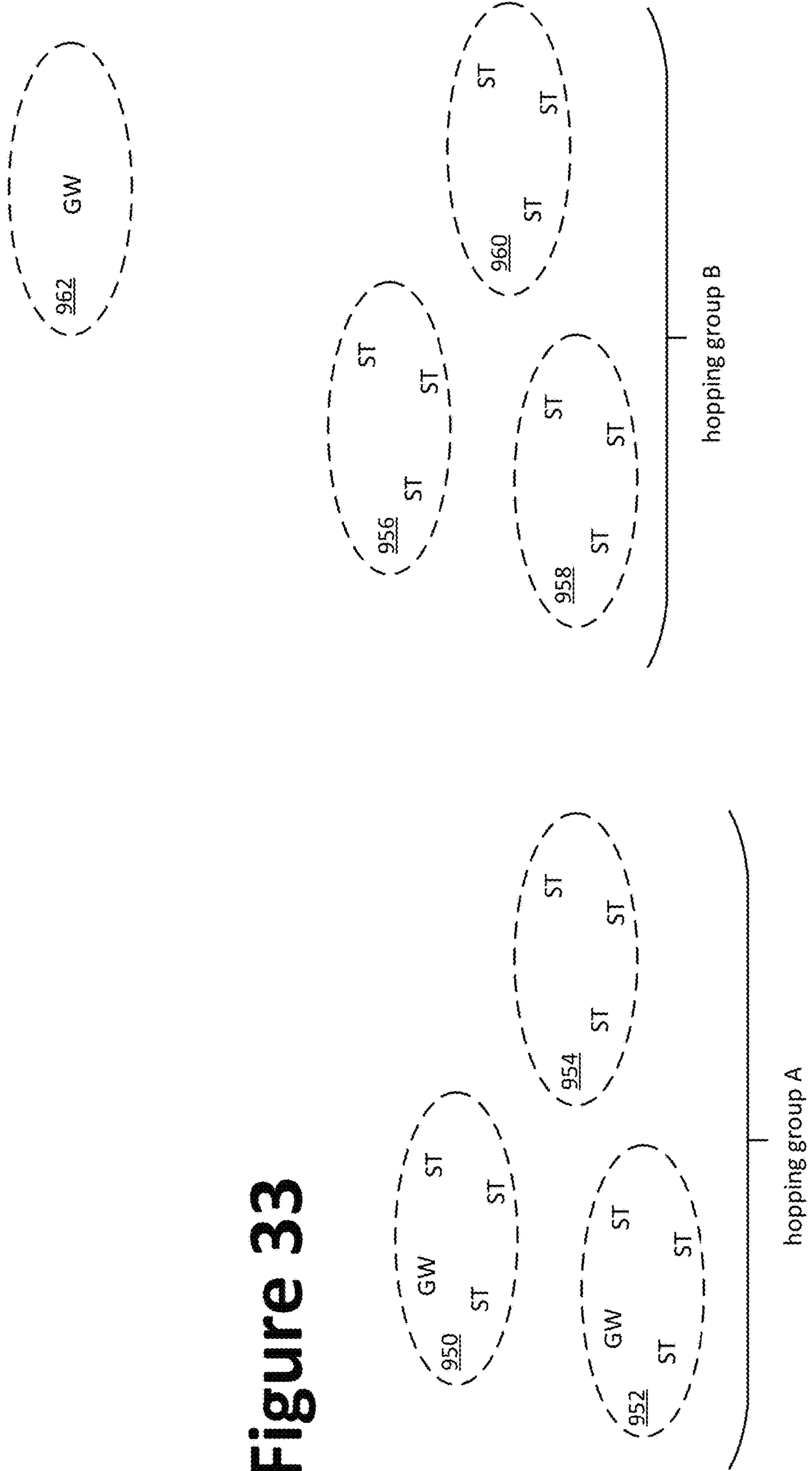
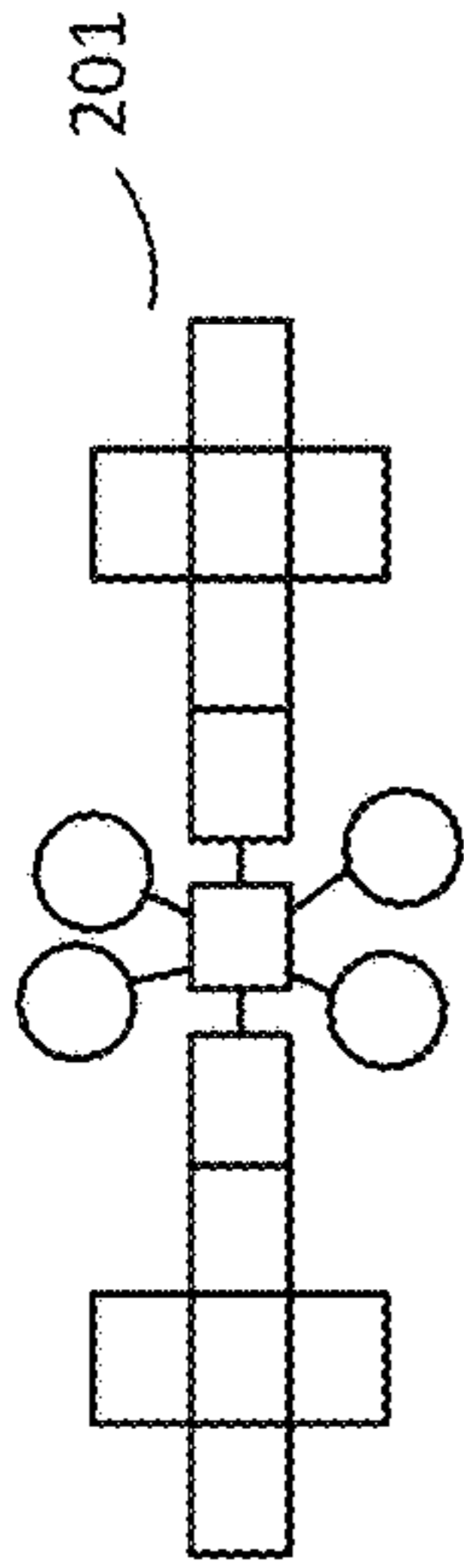

Figure 33

Figure 34

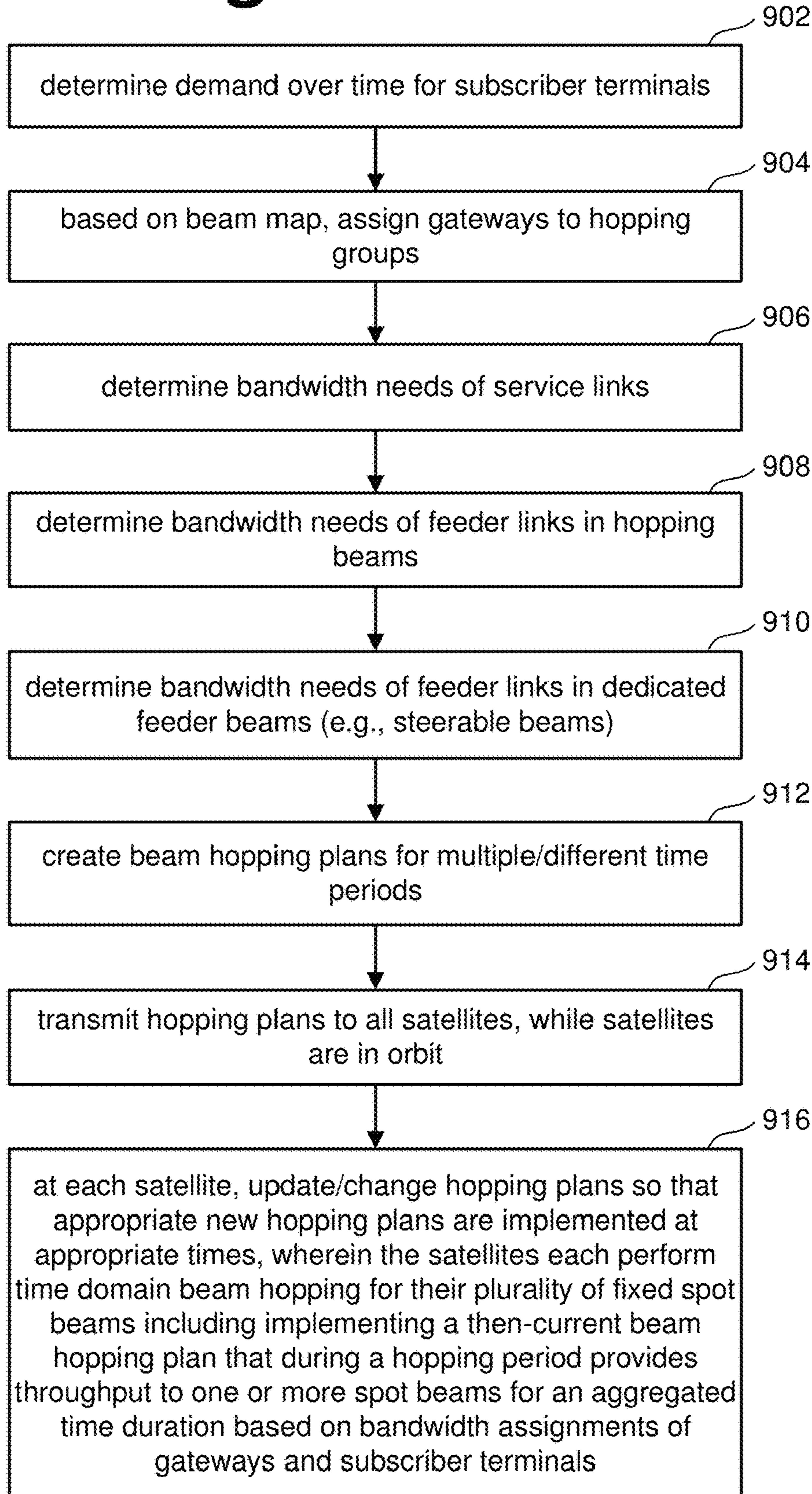

Figure 35

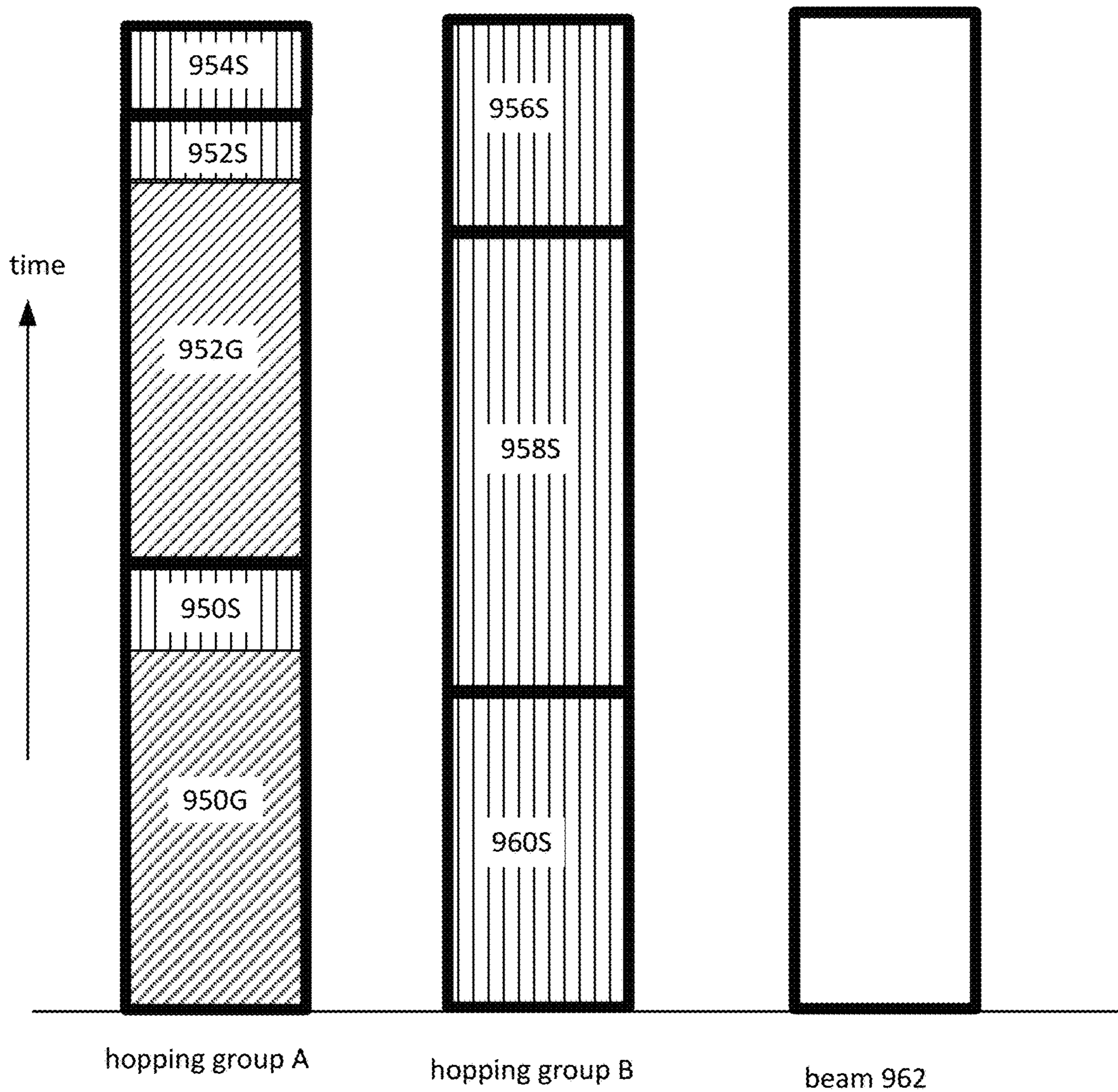

Figure 36

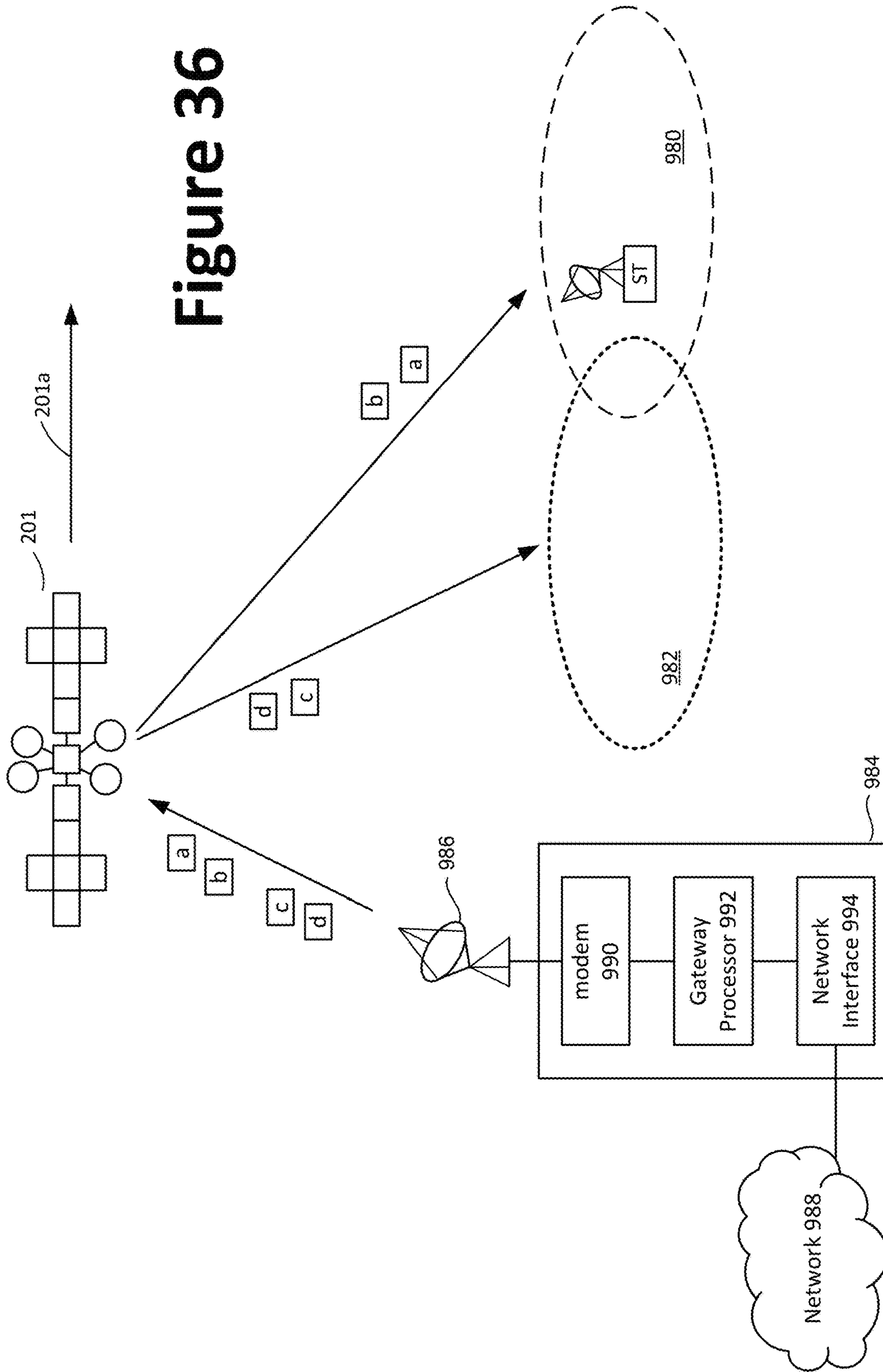

Figure 37

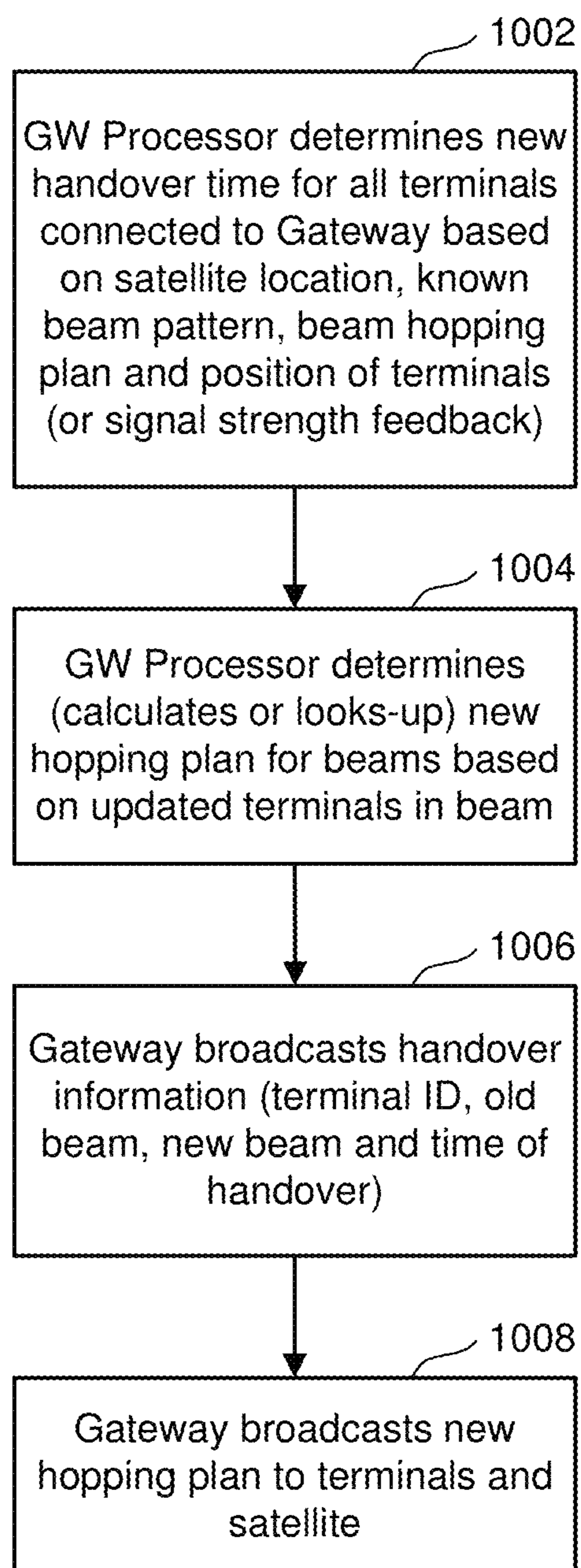
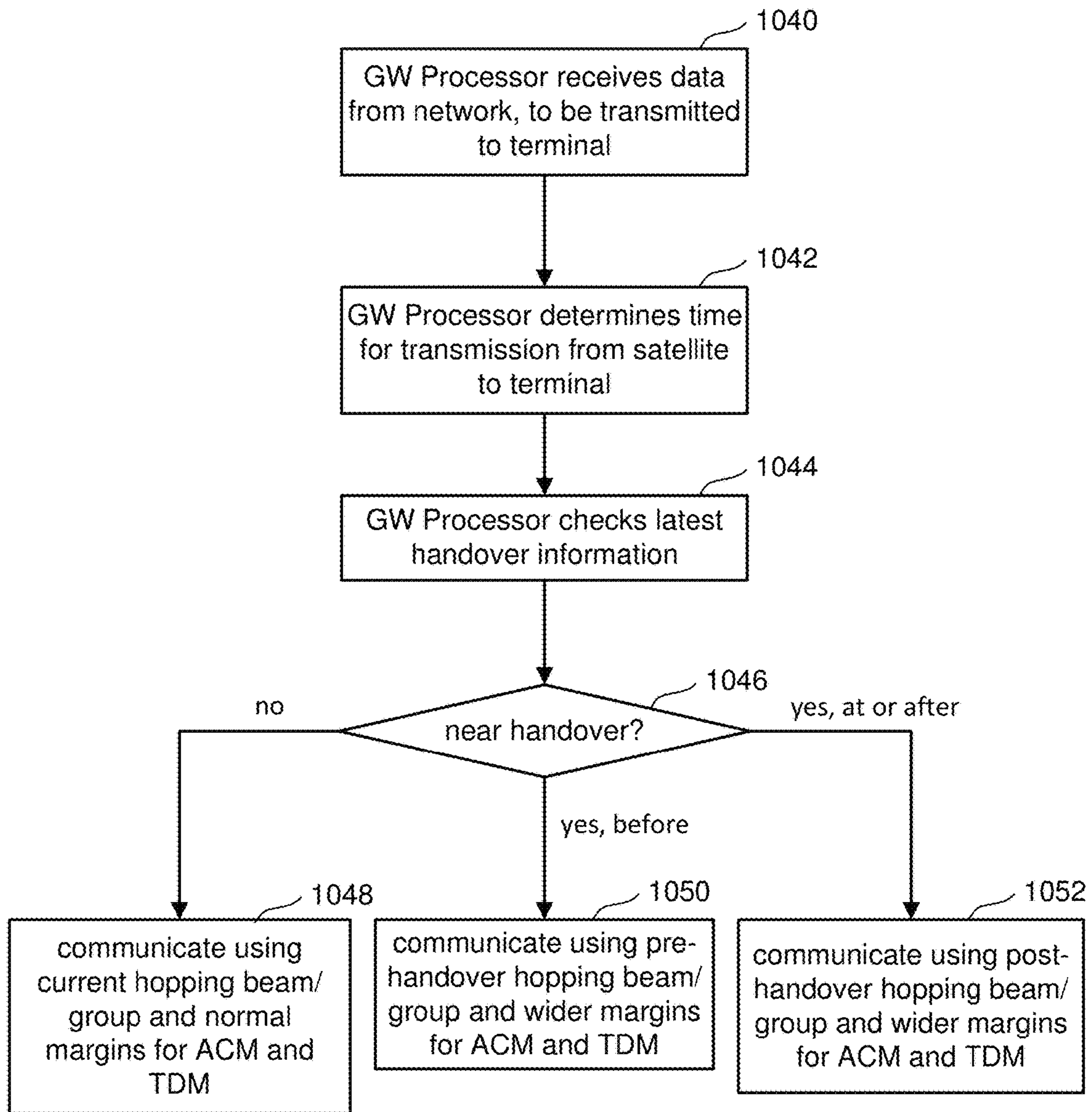

Figure 38



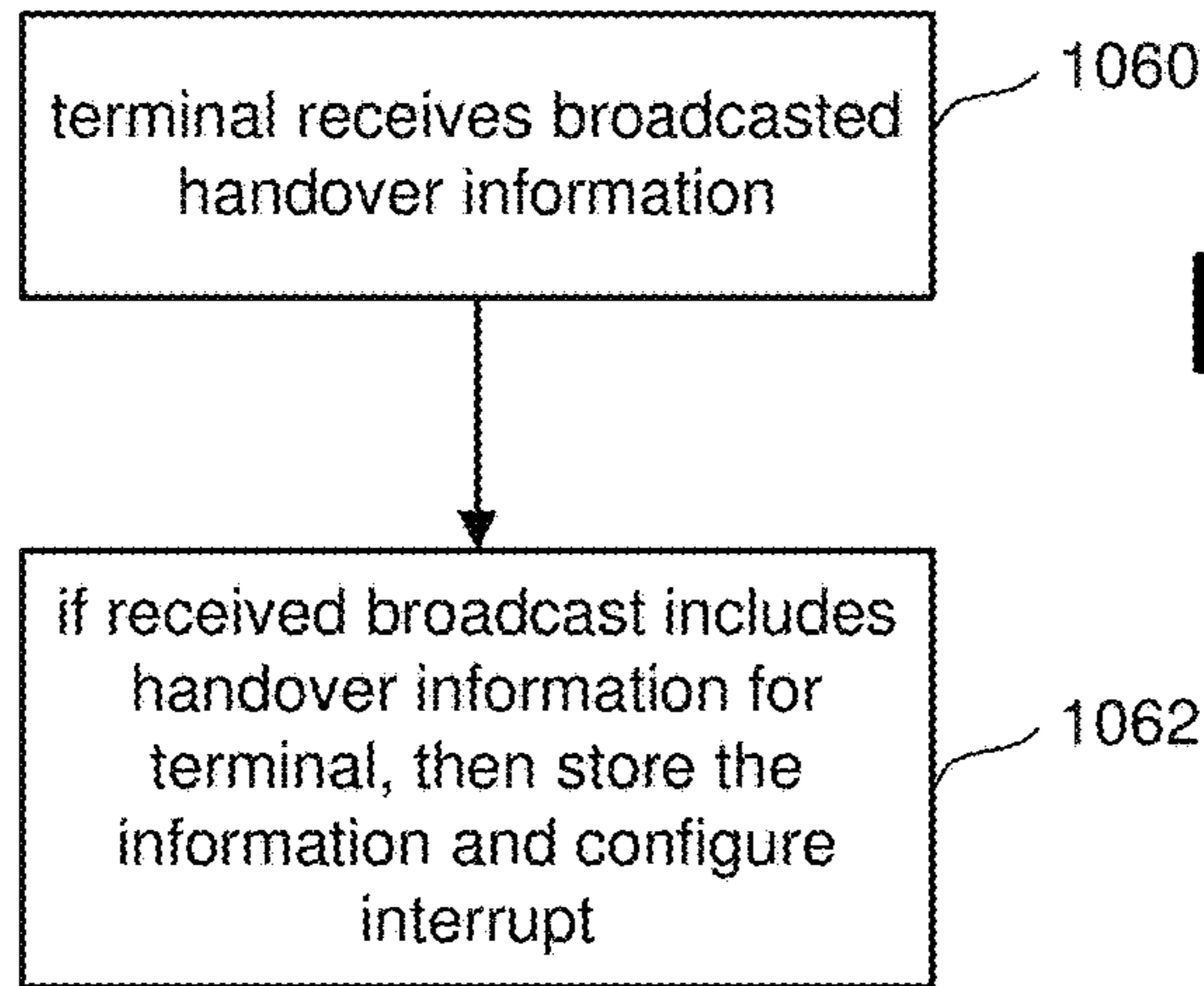

Figure 39

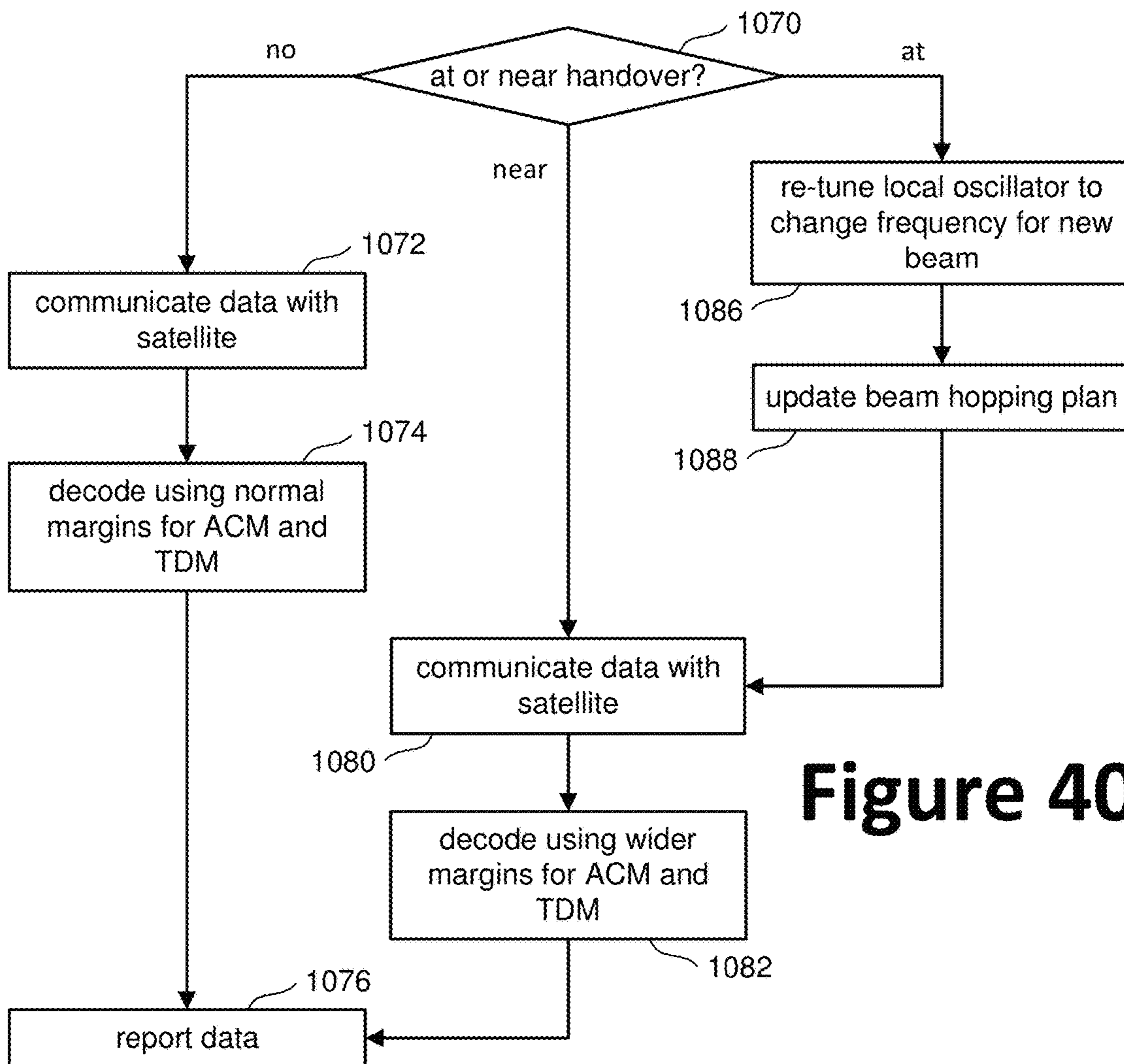

Figure 40

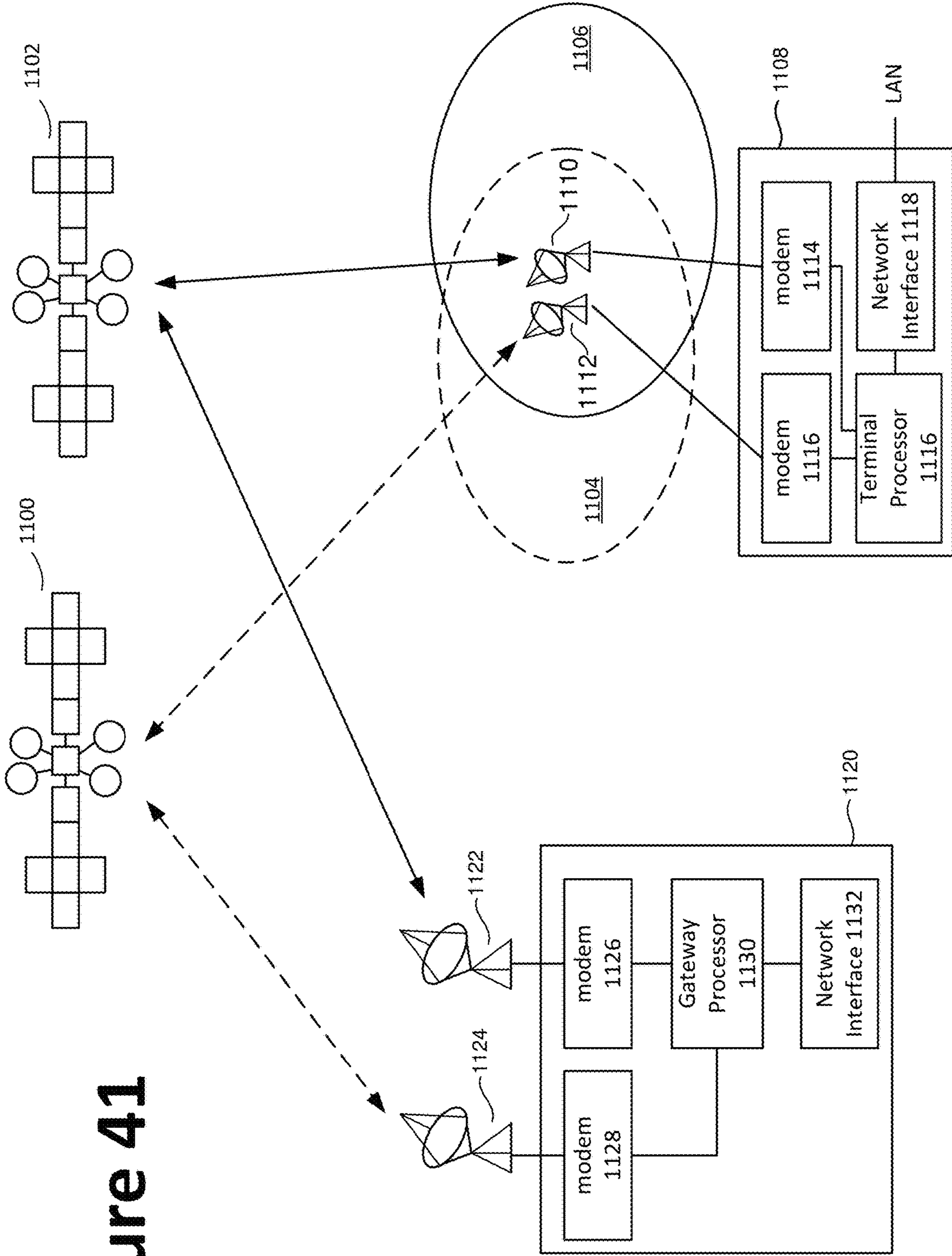

Figure 41

Figure 42

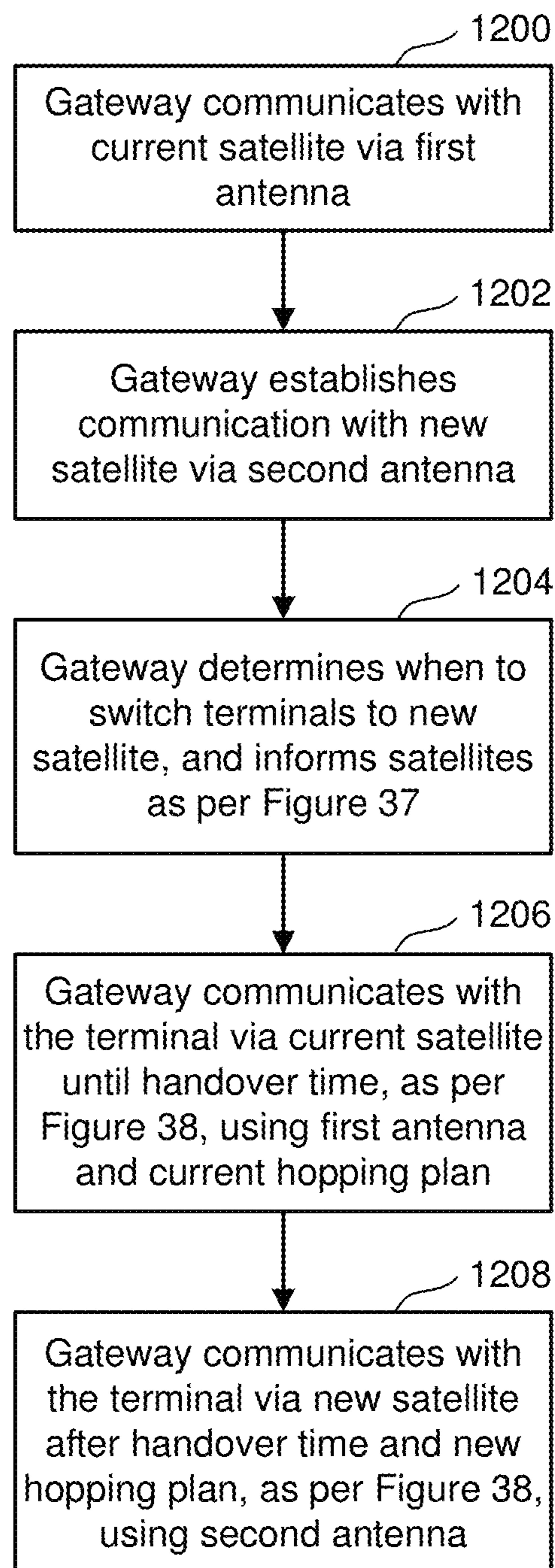

Figure 43

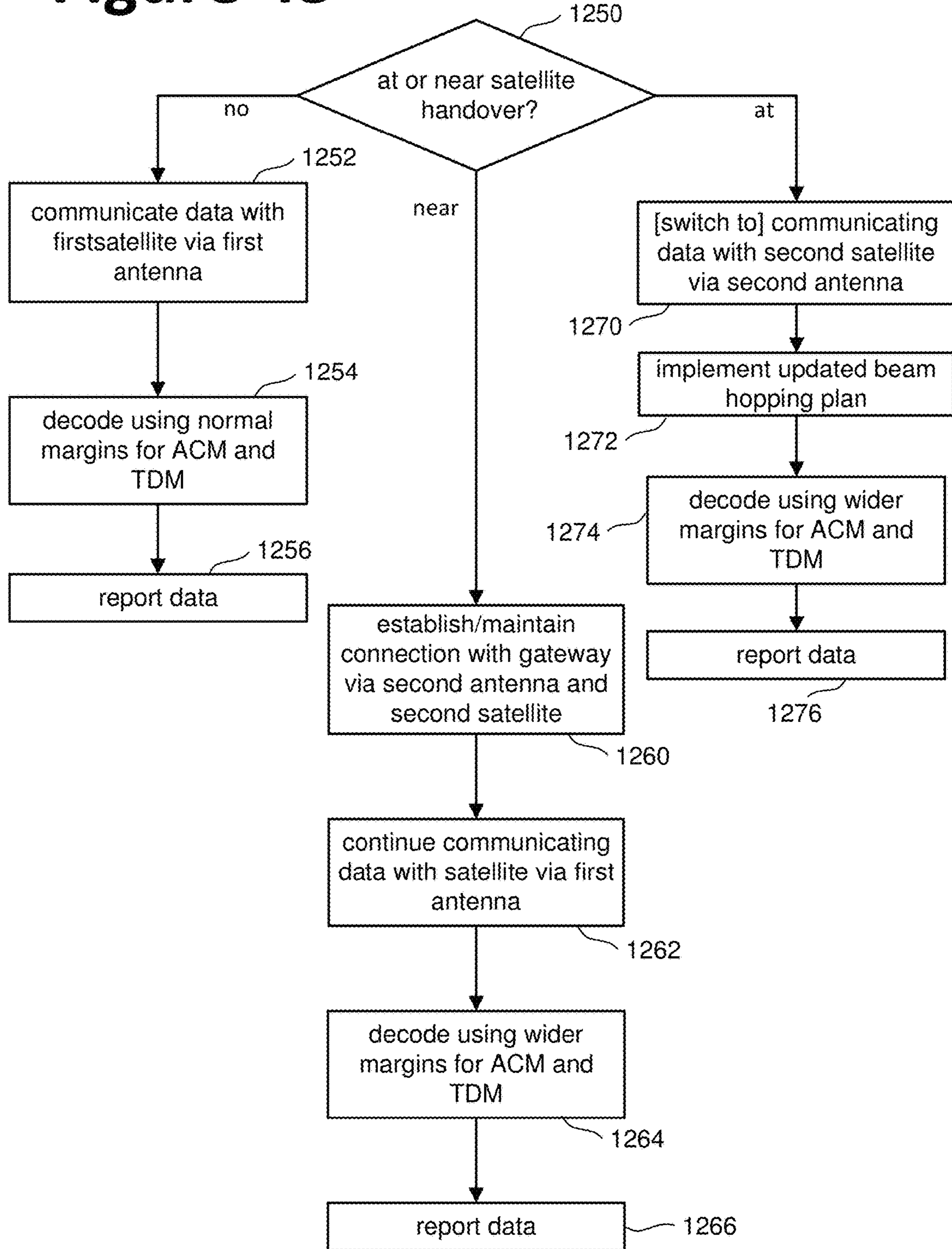

Figure 44

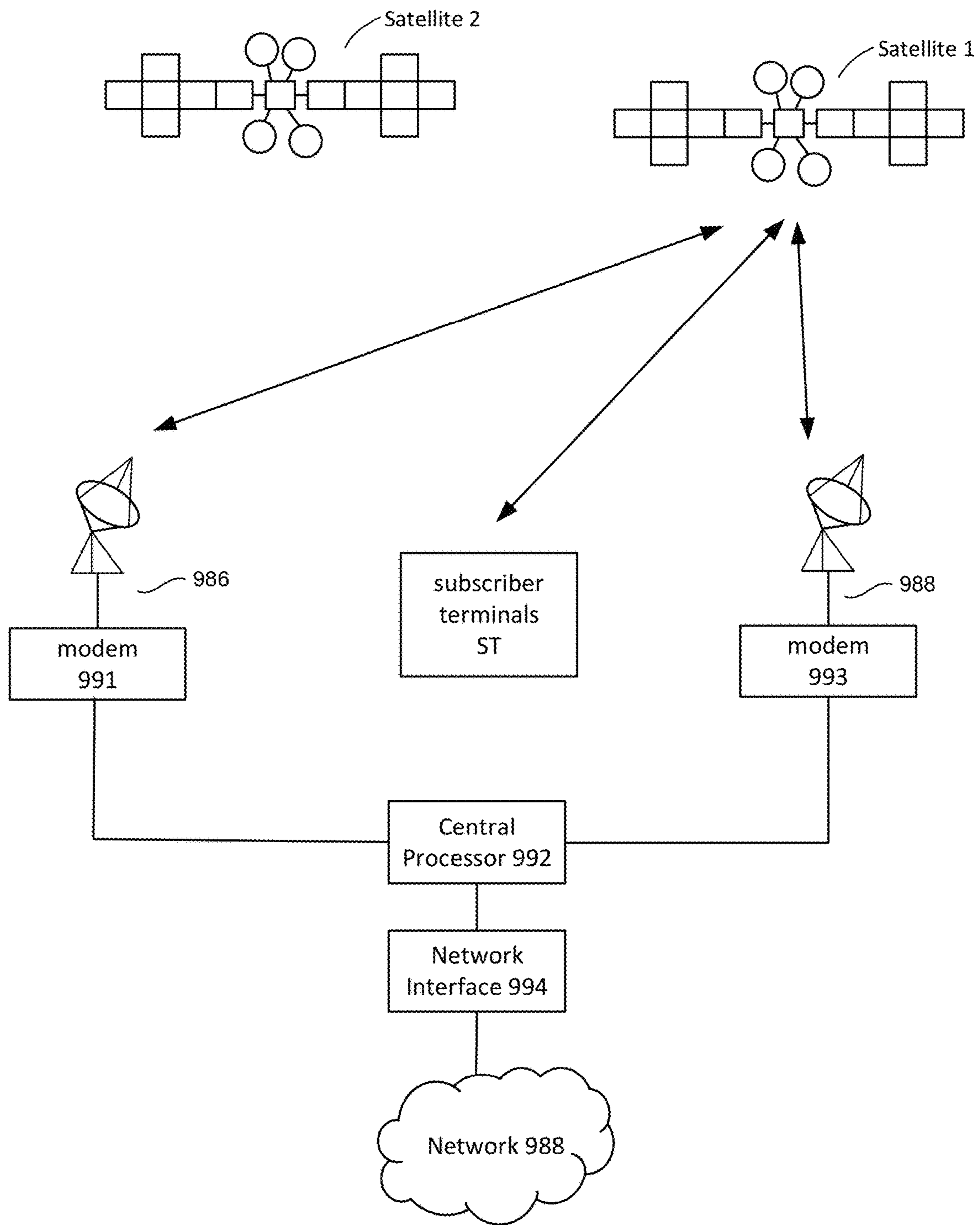
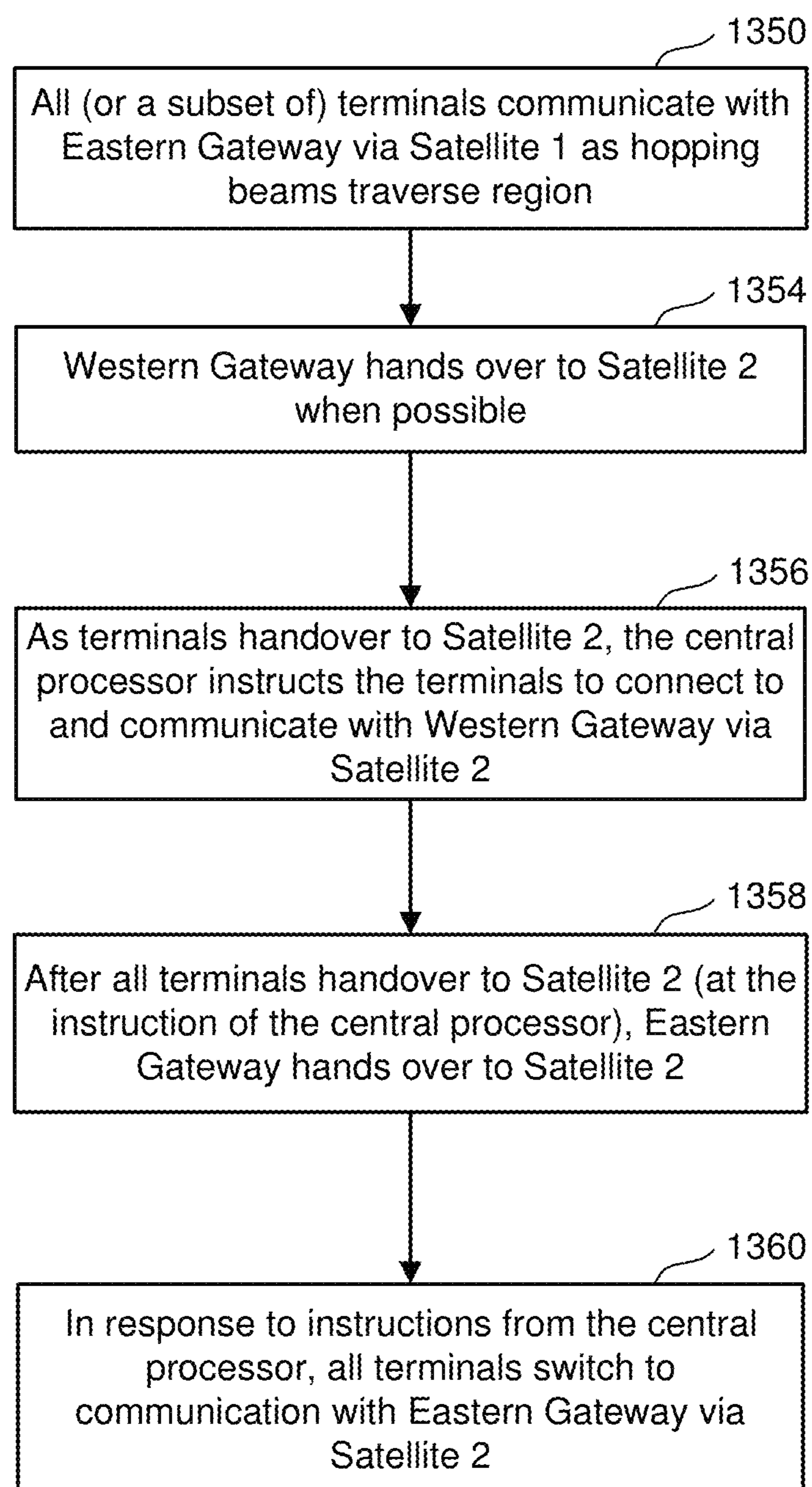
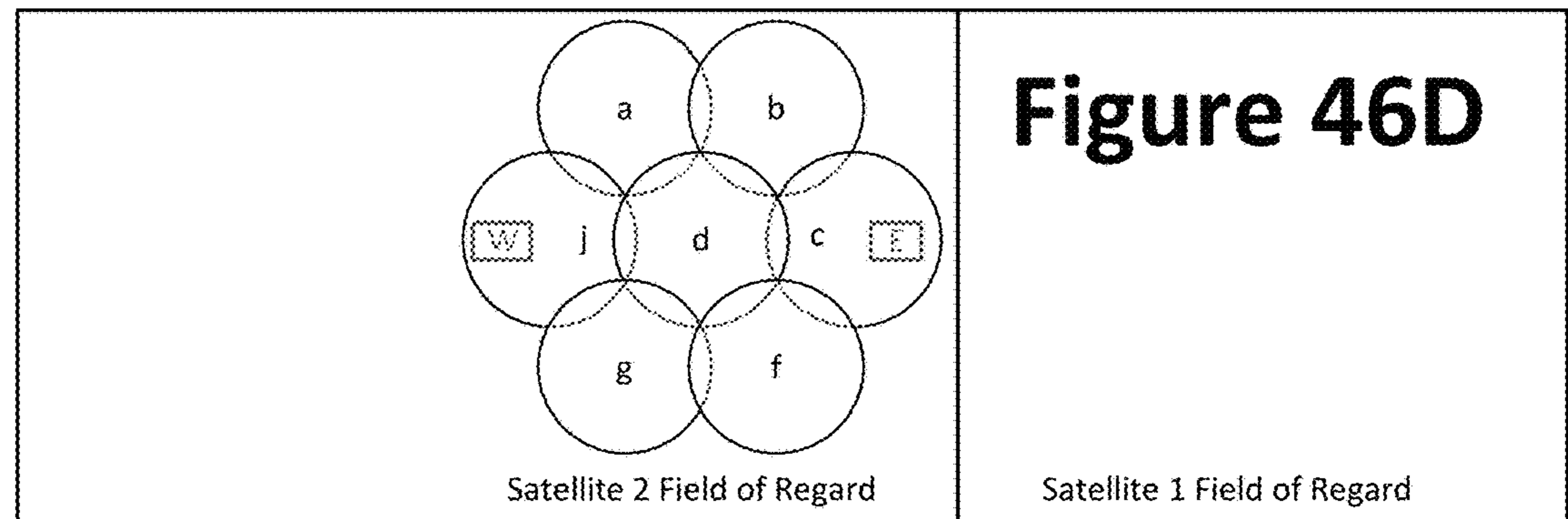
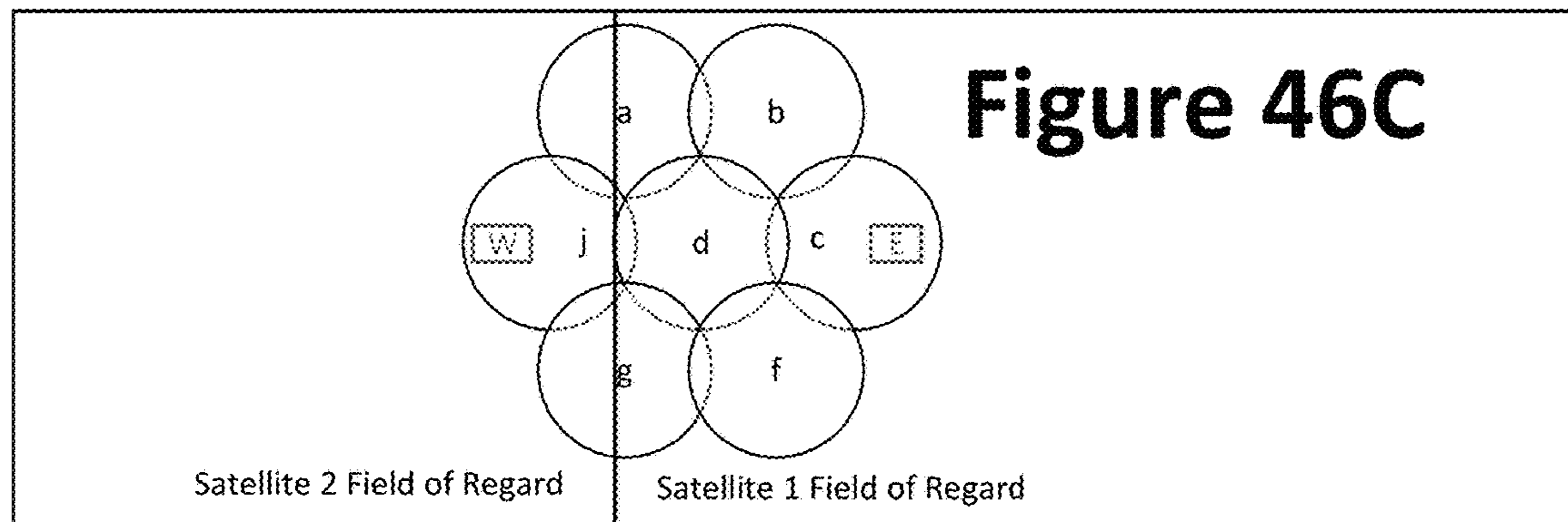
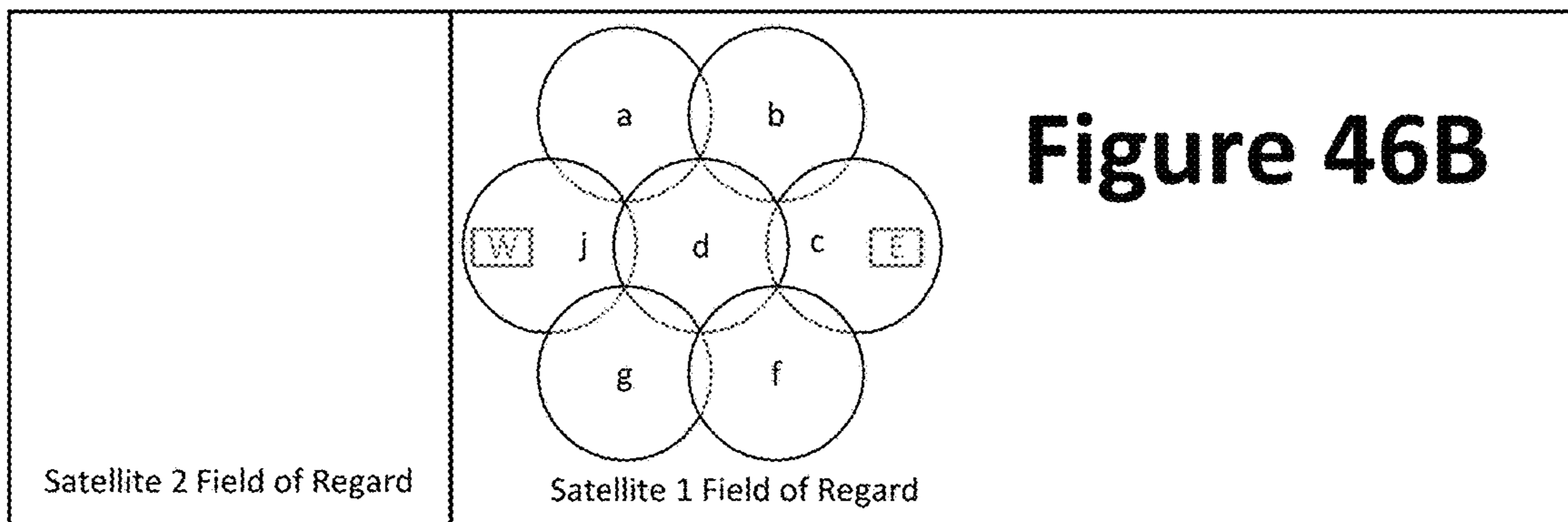
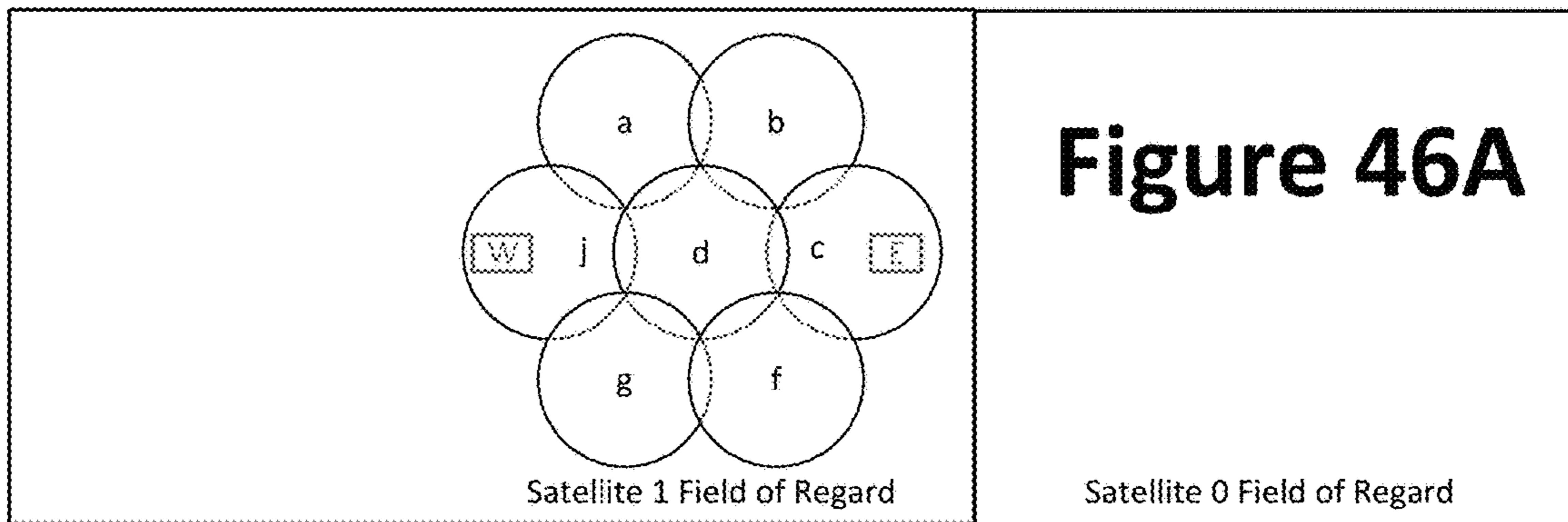

Figure 45





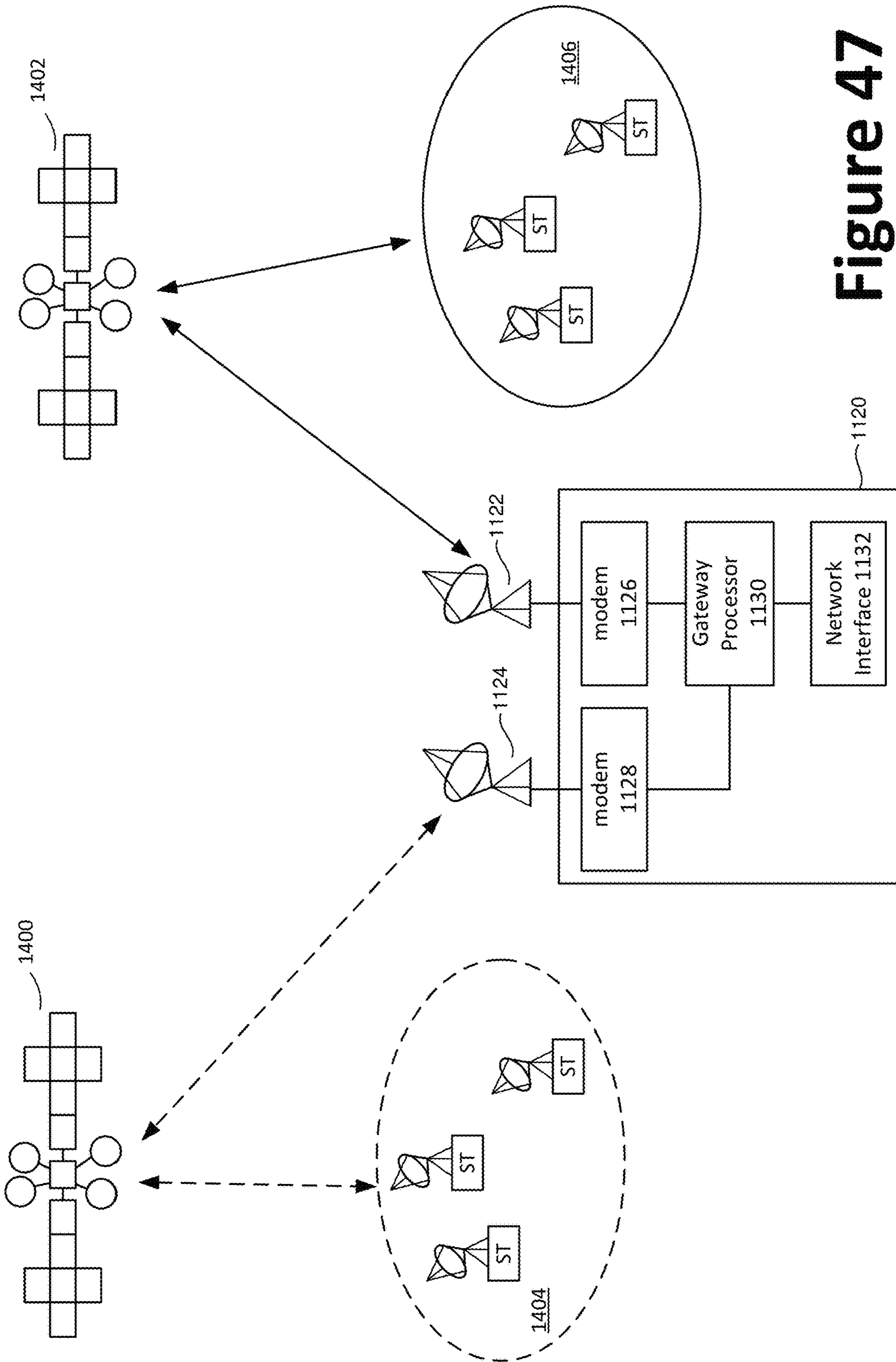
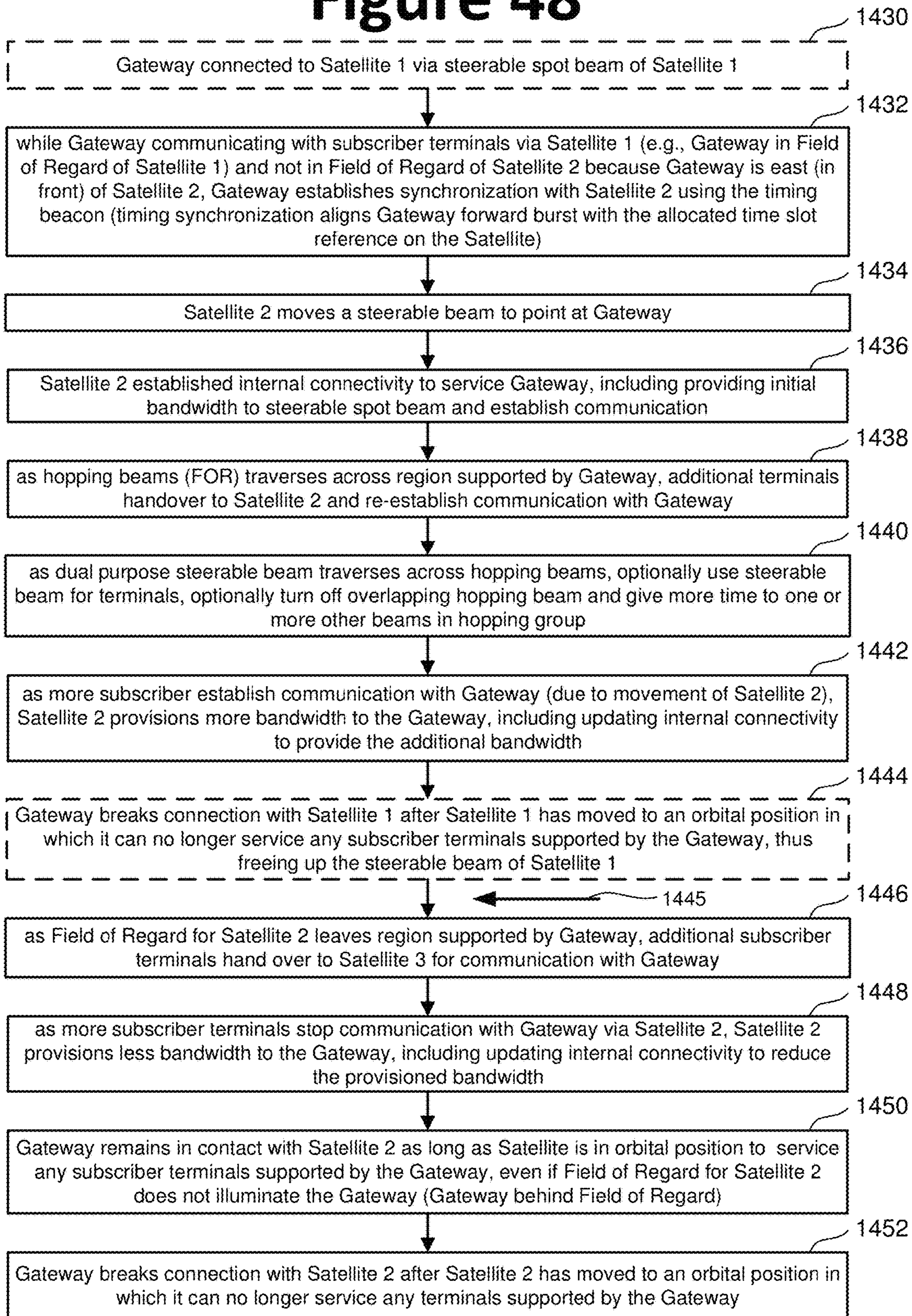

Figure 47

Figure 48



Field of Regard for Satellite 2

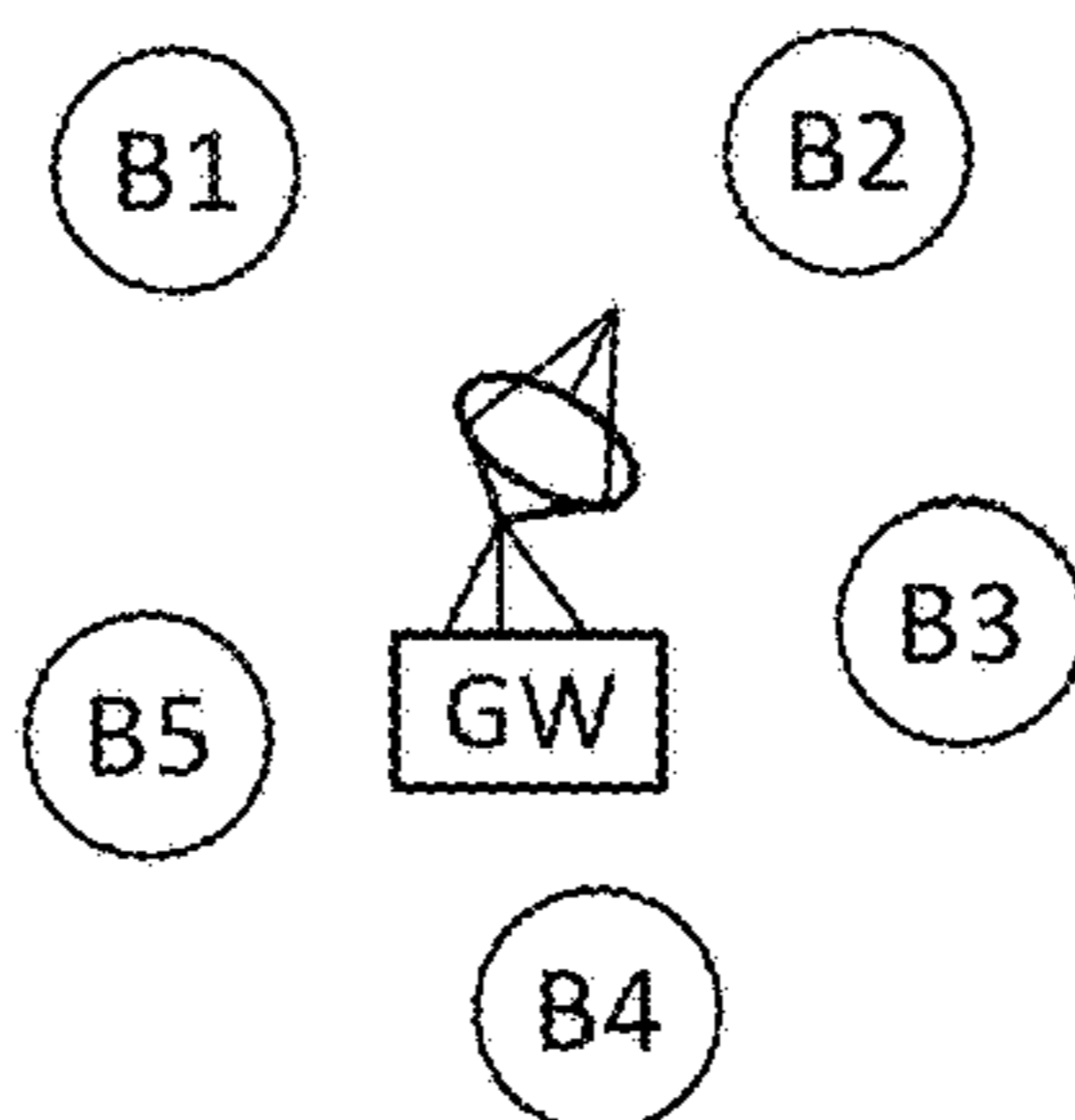
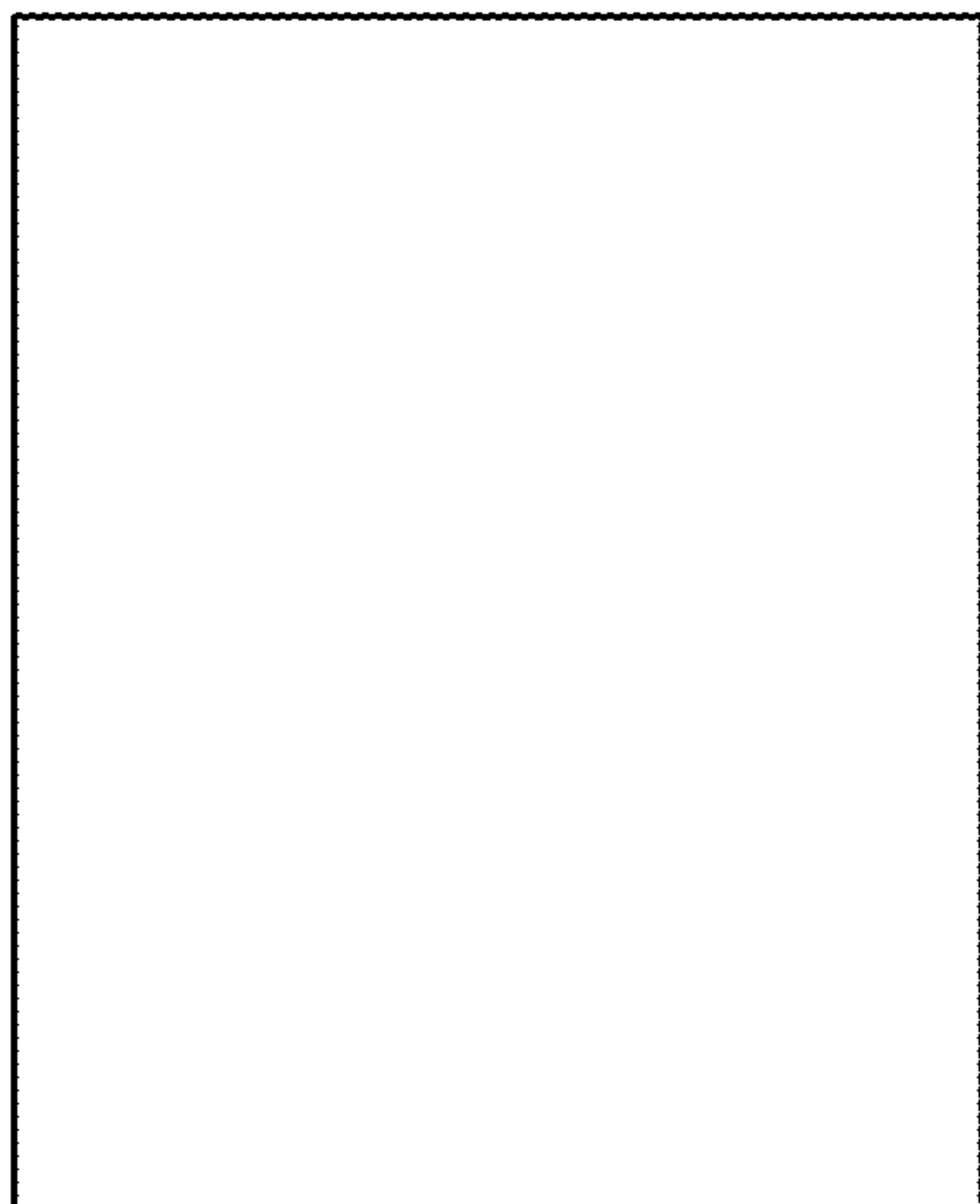

Figure 49A

Field of Regard for Satellite 2

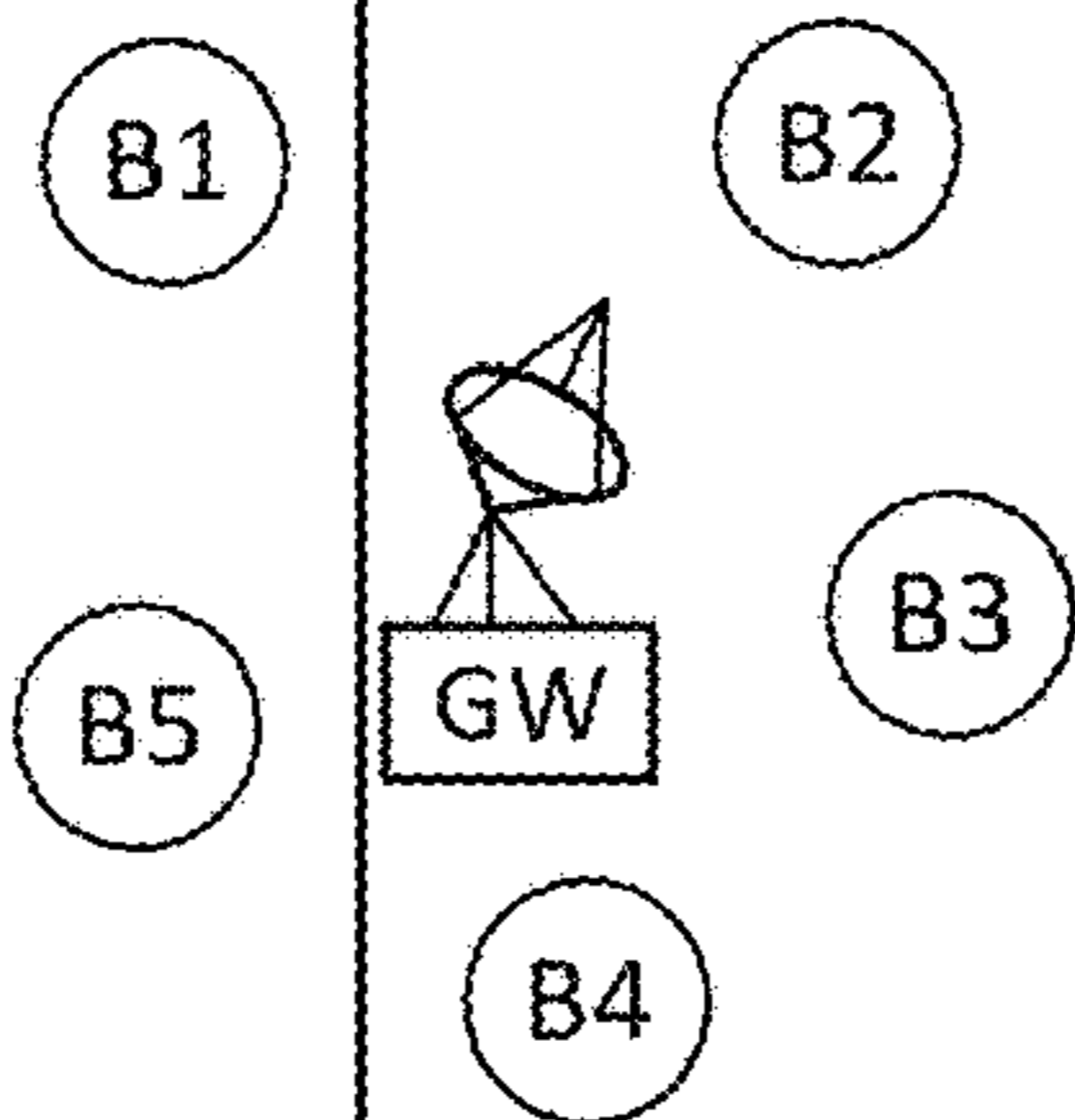
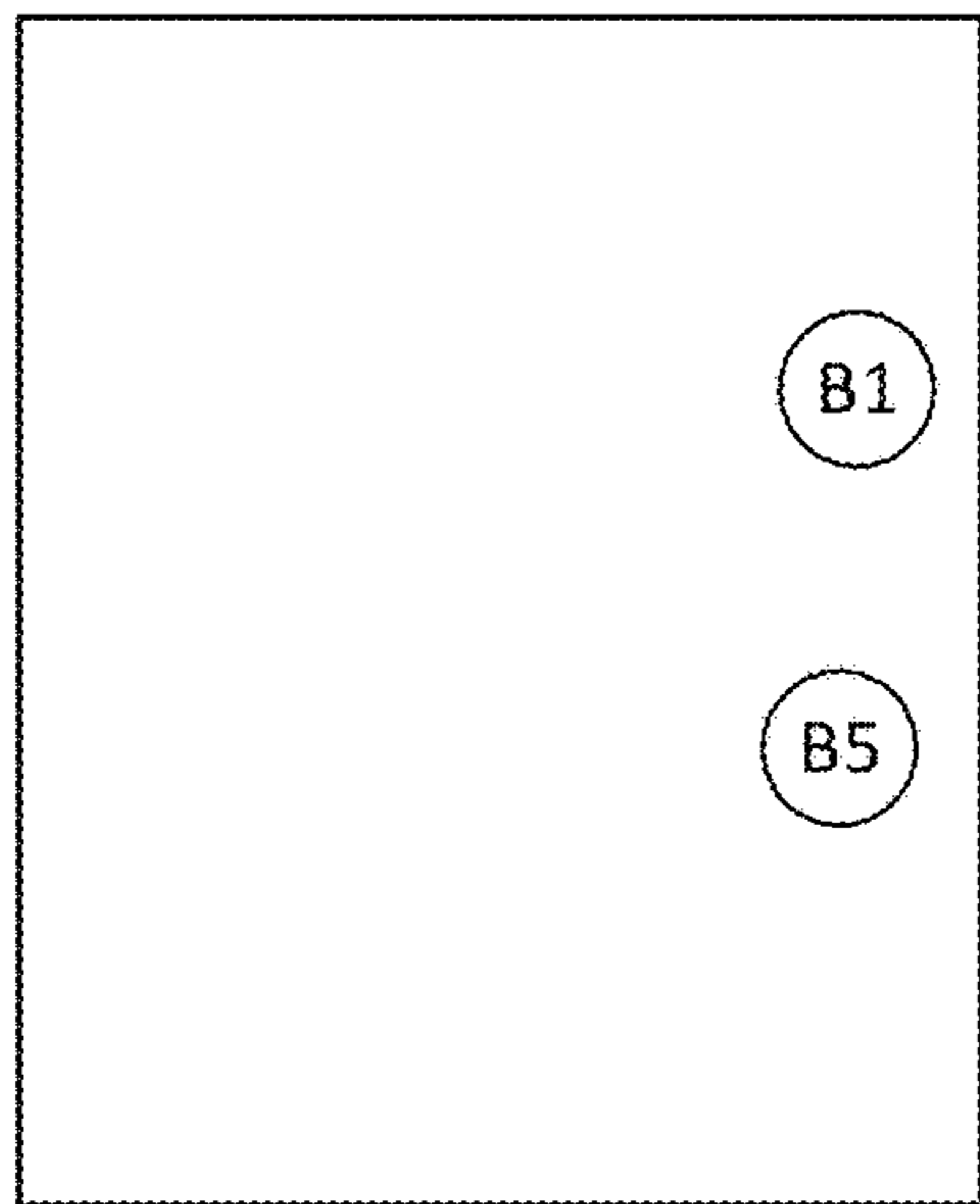

Figure 49B

Field of Regard for Satellite 2

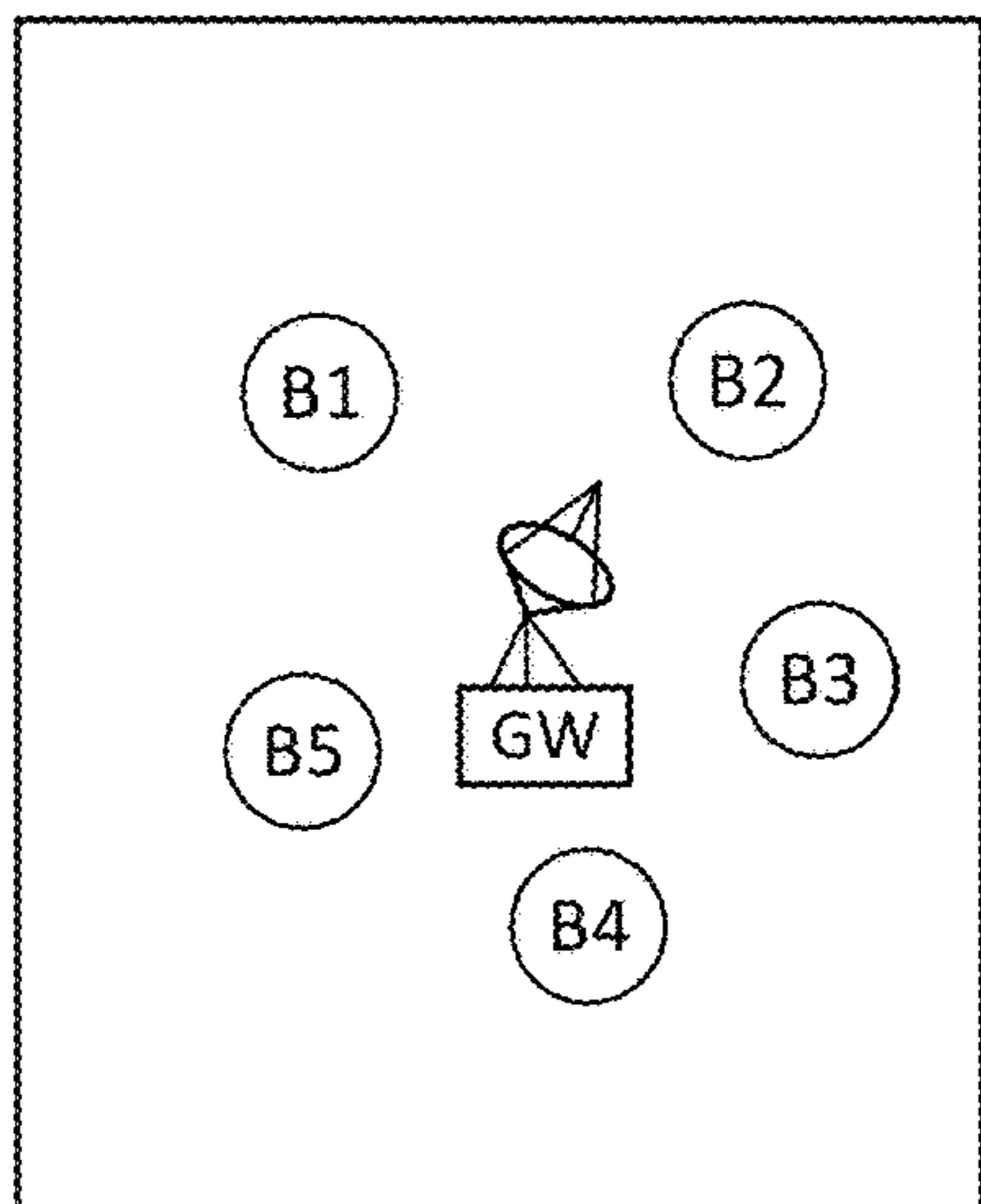

Figure 49C

Figure 49D

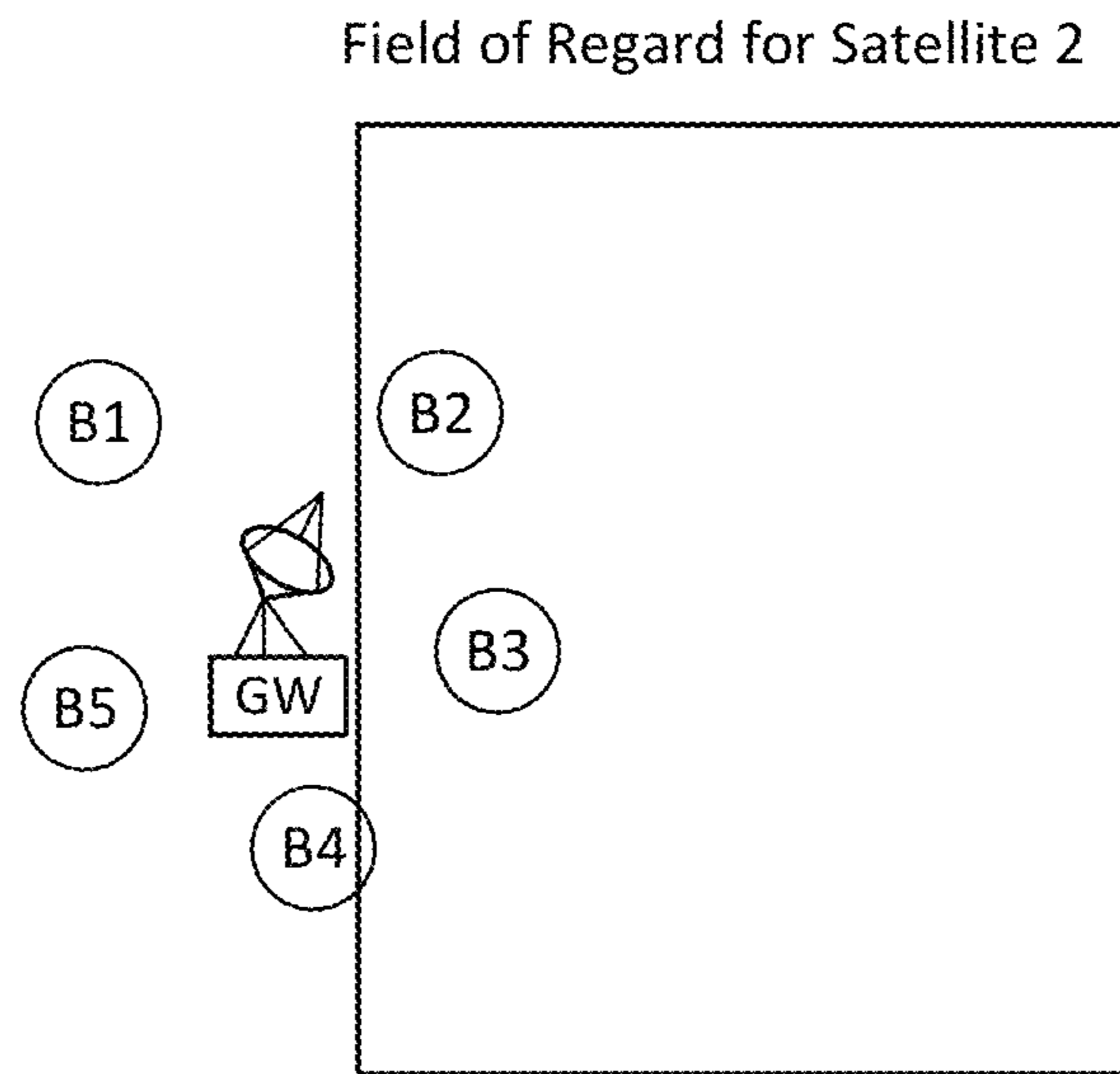

Figure 49E

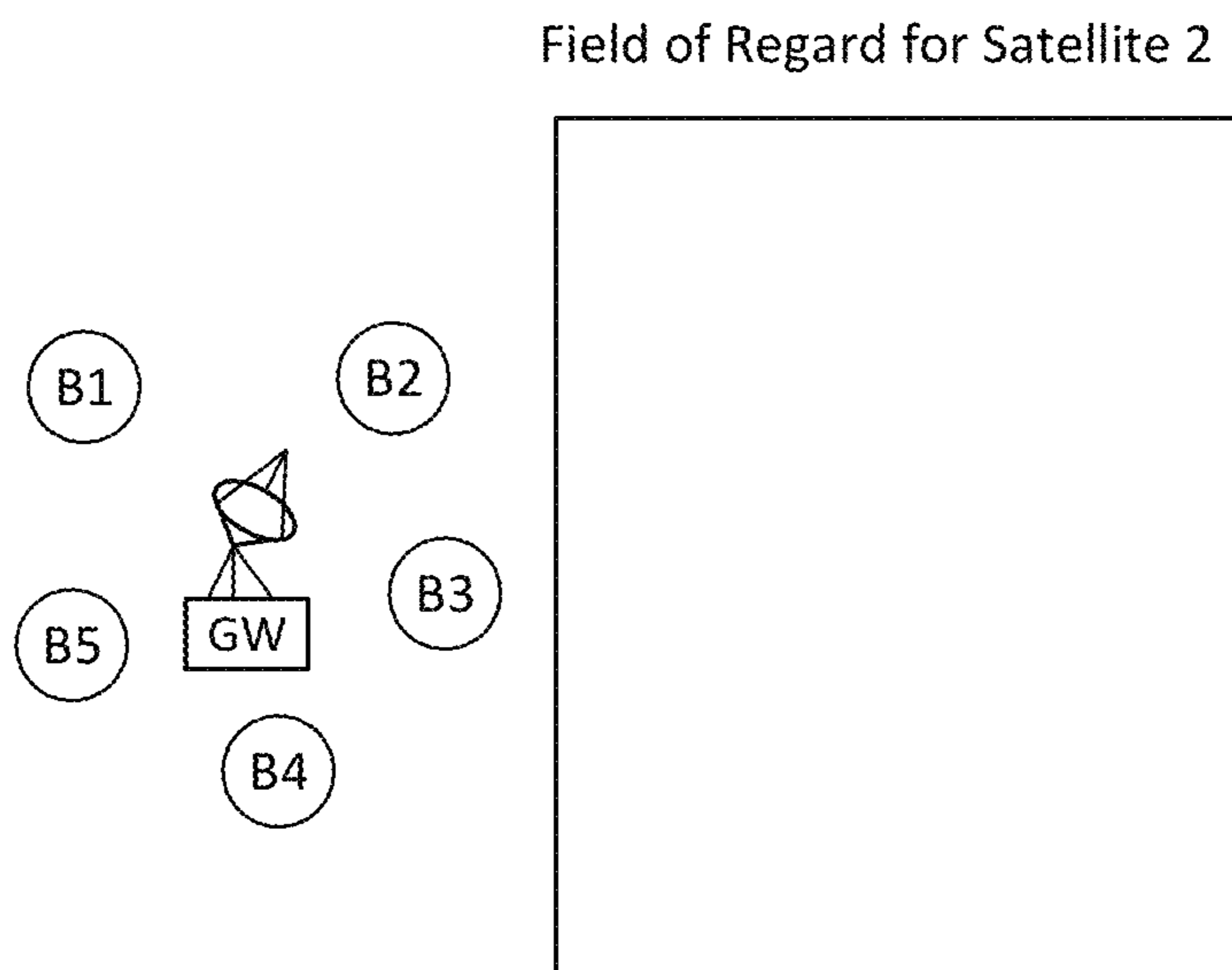

Figure 50

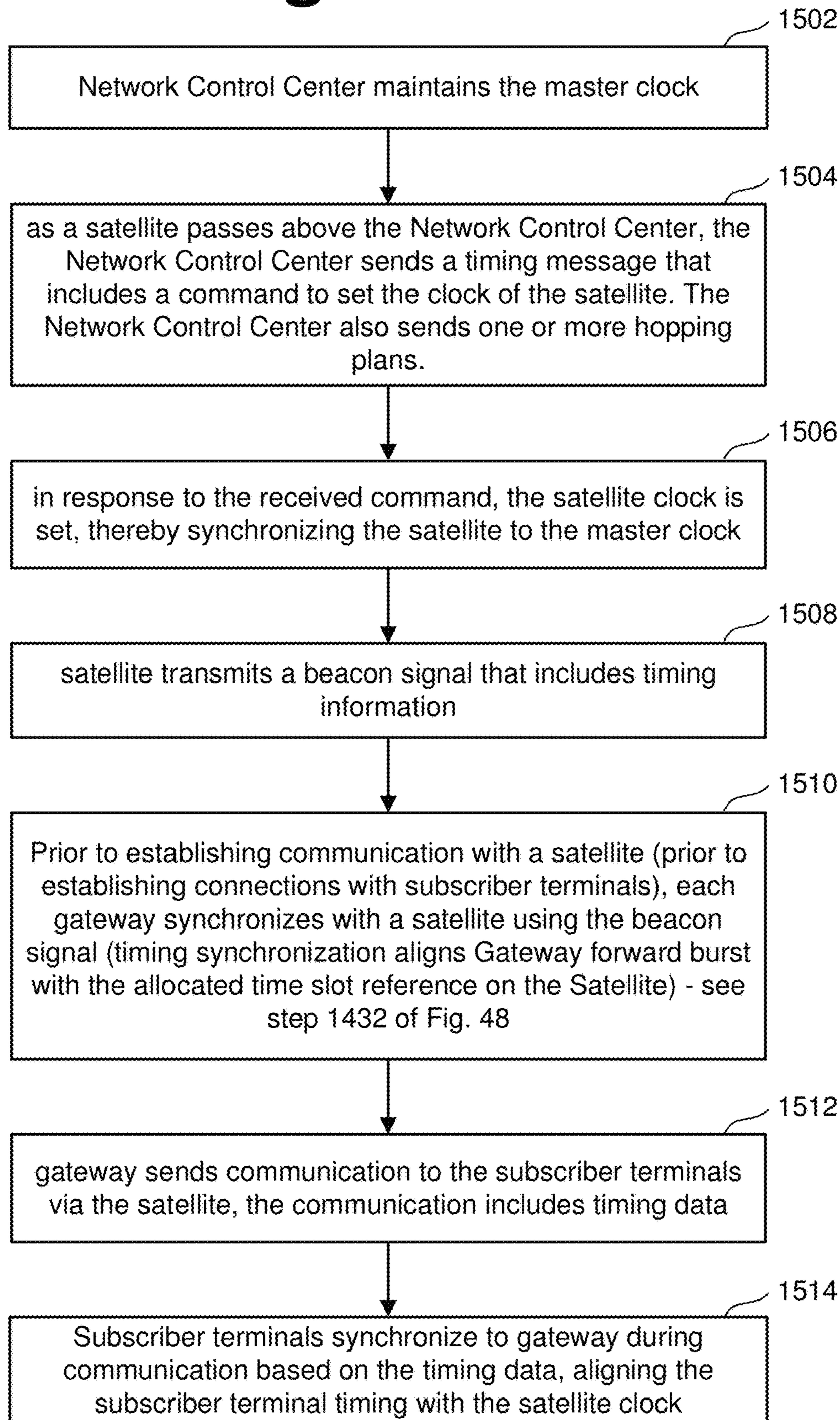

Figure 51

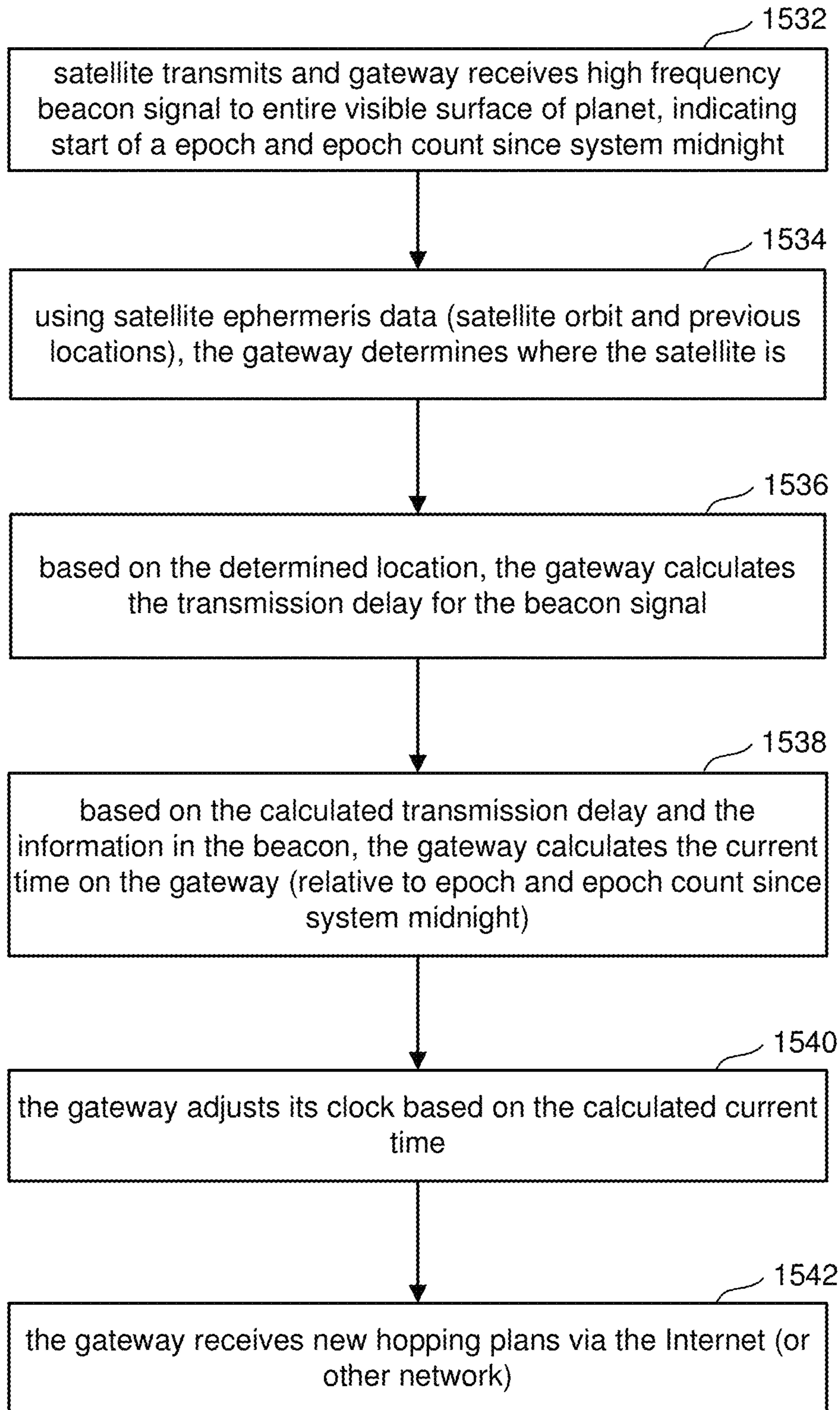

Figure 51A

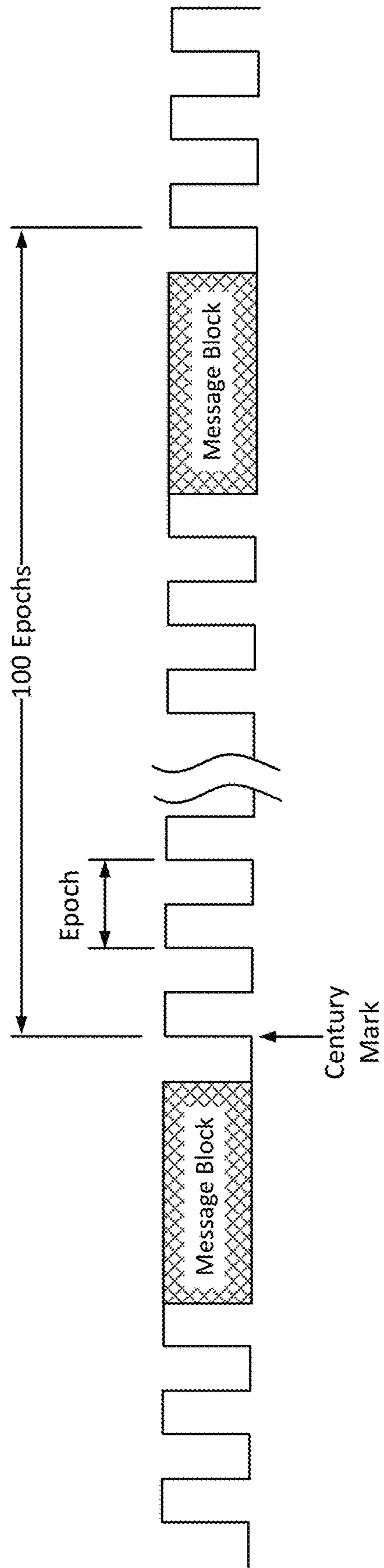

Figure 52

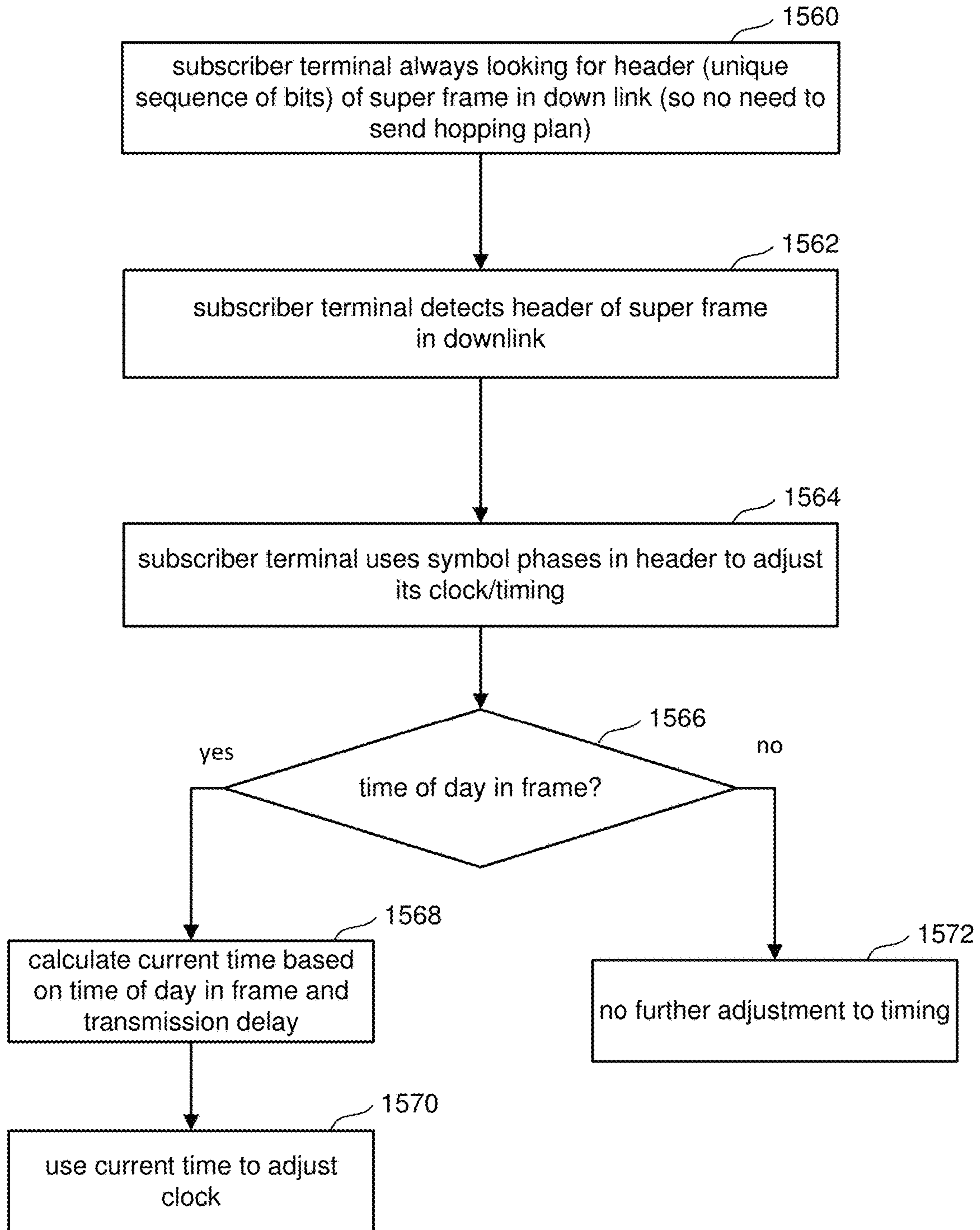
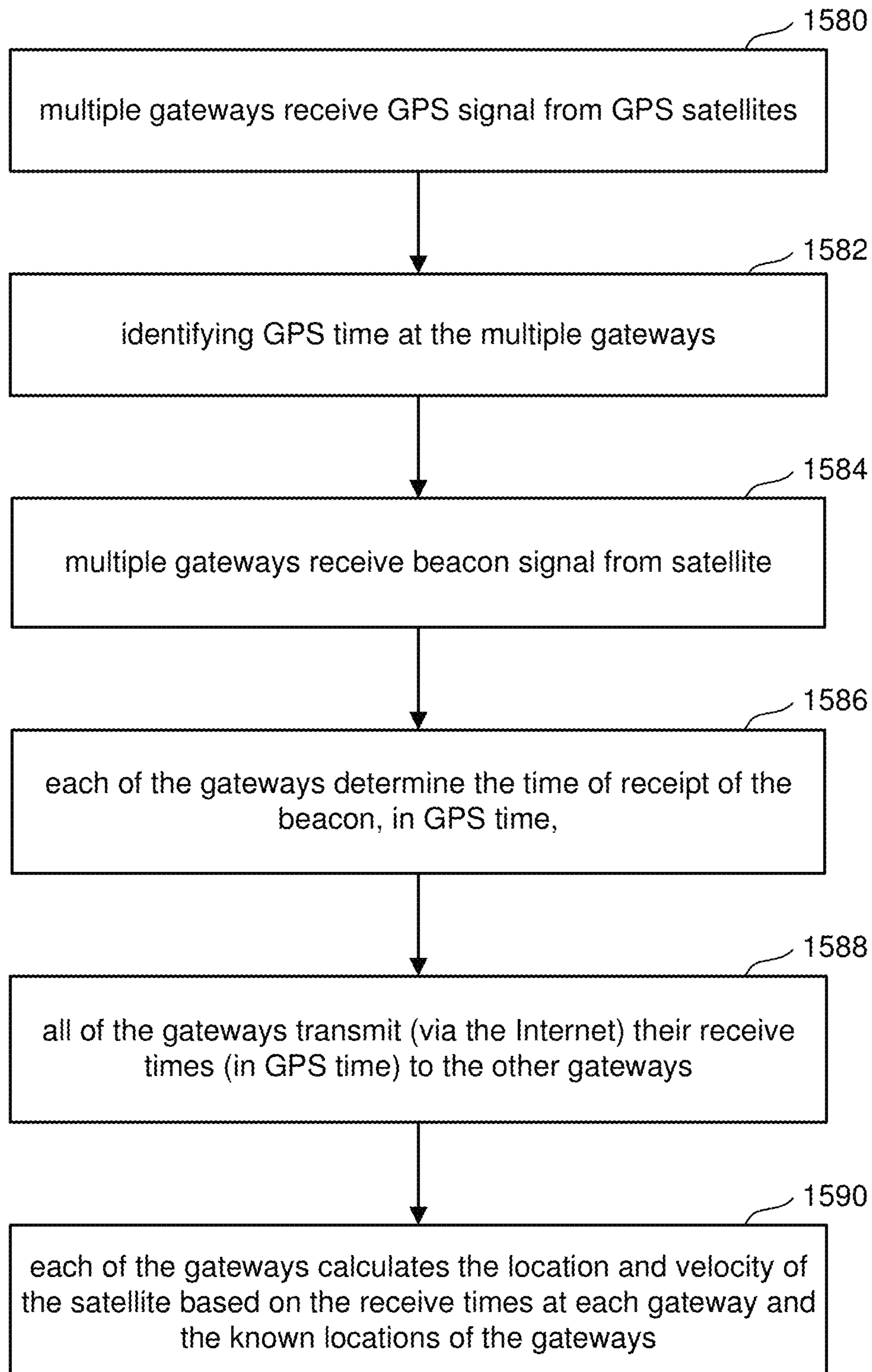

Figure 53



SYNCHRONIZATION FOR SATELLITE SYSTEM

This application claims priority to U.S. Provisional Application No. 62/314,938, "Non-Geostationary Satellite Constellation Communication System," filed on Mar. 29, 2016, incorporated herein by reference.

BACKGROUND

The present disclosure relates to technology for satellite communication systems.

Satellite communication systems typically include one or more satellites and a set of ground terminals. Such systems typically operate within regulations that allocate operating frequency bandwidth for a particular communications service and specify, among other things, a maximum signal power spectral density of communications signals radiated to the ground. A growing market exists for provision of high data rate communication services to individual consumers and small businesses which may be underserved by or unable to afford conventional terrestrial services. Satellite communication systems have been proposed to provide such high data rate communication services. However, designing a satellite system to meet these needs is challenging.

BRIEF DESCRIPTION OF THE DRAWINGS

FIG. 1 is a block diagram describing one embodiment of a portion of a satellite communications system.

FIG. 2 is a block diagram depicting a satellite and its antenna system.

FIG. 3 depicts a beam map for a Field of Regard.

FIG. 4 is a map of the world, showing a constellation of non-geostationary satellites,

FIG. 5 is a map of the world, showing the beam maps for eleven non-geostationary satellites.

FIG. 6 is a block diagram of one embodiment of a communications payload for a non-geostationary satellites.

FIG. 7 is a block diagram of one embodiment of a digital channelizer.

FIG. 8 depicts an example embodiment of an uplink frequency plan for beams away from the Equator.

FIG. 9 depicts an example embodiment of a downlink frequency plan for beams away from the Equator.

FIG. 10 is a beam map depicting one embodiment of an assignment of colors (frequency band+polarization) to spot beams.

FIG. 11 depicts an example uplink frequency plan for beams at the Equator.

FIG. 12 depicts an example downlink frequency plan for beams at the Equator.

FIG. 13 depicts a beam map.

FIG. 13A is a flow chart describing one embodiment of a process for operating a constellation of satellites with different frequency plans and different hopping plans between beams at the Equator and beams away from the Equator.

FIGS. 14A and 14B depict example beam polarization maps.

FIGS. 15A, 15B, 15C, 15D, 15E and 15F depict example beam maps.

FIG. 15G is a flow chart describing one embodiment of a process for operating a satellite communications system, including changing frequencies for subscriber terminals without the need to change polarization as the satellites move with respect to the subscriber terminals.

FIG. 15H is a flow chart describing one embodiment of a process for operating a satellite communications system, including implementing satellite handovers.

FIGS. 16A, 16B, and 16C depict example beam maps.

FIGS. 17A, 17B, 17C, 17D, and 17E depict example beam maps.

FIG. 18 is a timing diagram describing time domain beam hopping.

FIG. 19 is a flow chart describing one embodiment of a process for performing time domain beam hopping.

FIG. 20A depicts an example beam map showing hopping groups away from the Equator.

FIG. 20B depicts an example beam map showing hopping groups at the Equator.

FIG. 21 is a table providing an example assignment of hopping groups away from the Equator.

FIG. 22 is a table providing an example assignment of hopping groups at the Equator.

FIG. 23 depicts an example beam map showing the Field of Regard, depicting a moment in time and graphically indicating which subset of spot beams of the various hopping groups are active in the current epoch.

FIG. 24 describes a portion of one example of a beam hopping plan.

FIG. 25 depicts timing for one embodiment of a super-frame.

FIG. 26 depicts content of one embodiment of a super-frame.

FIG. 27 depicts an example of a payload of a super-frame.

FIG. 28 depicts a portion of a satellite communication system, showing sample transmission times.

FIG. 29 is a flow chart describing one embodiment of a process for performing time domain beam hopping with a constellation of non-geostationary satellites that can dynamically change beam hopping plans.

FIG. 30 describes a portion of one example of a beam hopping plan, and depicts time multiplexing of gateways.

FIG. 31 is a flow chart describing one embodiment of a process for performing time domain beam hopping and time multiplexing gateways.

FIG. 32 is a flow chart describing one embodiment of a process for performing time domain beam hopping on a satellite.

FIG. 33 depicts a portion of a satellite communication system, showing a satellite that is configured to implement a beam hopping plan that during a hopping period provides throughput to a first spot beam for an aggregated time duration based on bandwidth assignments to the first gateway and the first set of subscriber terminals.

FIG. 34 is a flow chart describing one embodiment of a process for performing time domain beam hopping, taking into account the bandwidth needs of the subscriber terminal and the gateway.

FIG. 35 is a chart describing one example of sharing capacity by dividing up epochs or capacity units based on pro-rate bandwidth needs.

FIG. 36 depicts a portion of a satellite communication system, showing a handover of a subscriber terminal between spot beams on a same satellite.

FIG. 37 is a flow chart describing one embodiment of a gateway process for performing a handover of a subscriber terminal between spot beams on a same satellite.

FIG. 38 is a flow chart describing one embodiment of a gateway process for performing a handover of a subscriber terminal between spot beams on a same satellite.

FIG. 39 is a flow chart describing one embodiment of a subscriber terminal process for performing a handover of the subscriber terminal between spot beams on a same satellite.

FIG. 40 is a flow chart describing one embodiment of a subscriber terminal process for performing a handover of the subscriber terminal between spot beams on a same satellite.

FIG. 41 depicts a portion of a satellite communication system, showing a handover of a subscriber terminal between spot beams of different satellites.

FIG. 42 is a flow chart describing one embodiment of a gateway process for performing a handover of a subscriber terminal between spot beams on different satellites.

FIG. 43 is a flow chart describing one embodiment of a subscriber terminal process for performing a handover of the subscriber terminal between spot beams on different satellites.

FIG. 44 depicts a portion of a satellite communication system, showing two cooperating gateways operating within hopping beams and communicating with hopping beams.

FIG. 45 is a flow chart describing one embodiment of a process for performing a handover of gateways between satellites, where the gateways are operating within hopping beams and communicating with hopping beams.

FIGS. 46A, 46B, 46C, and 46D depict Fields of Regards of two satellites moving over coverage areas.

FIG. 47 depicts a portion of a satellite communication system, showing a gateway connecting to steerable spot beams of two satellites for performing a handover.

FIG. 48 is a flow chart describing one embodiment of a process for performing a handover for gateways communicating with steerable spot beams of the satellites in the constellation.

FIGS. 49A, 49B, 49C, 49D and 49E depict a Field of Regard of a satellite moving over coverage regions as the satellite orbits the Earth.

FIG. 50 is a flow chart describing one embodiment of a process for performing timing synchronization for the satellite communication system.

FIG. 51 is a flow chart describing one embodiment of a process for synchronizing a gateway to a satellite.

FIG. 51A depicts an example beacon signal.

FIG. 52 is a flow chart describing one embodiment of a process for synchronizing a subscriber terminal to a gateway.

FIG. 53 is a flow chart describing one embodiment of a process performed by gateways to automatically determine a location of a satellite.

DETAILED DESCRIPTION

System Overview

A satellite communication system is proposed that comprises a constellation of non-geostationary satellites orbiting the Earth, a plurality of gateways and a plurality of subscriber terminals (also referred to as terminals). The subscriber terminals communicate with the gateways via the satellites, as the satellites move in orbit. Each of the satellites provide a plurality of non-articulated spot beams that implement time domain beam hopping and a plurality of steerable spot beams for communicating with the gateways and subscriber terminals. The system can be used to provide access to the Internet or other network, telephone services, video conferencing services, private communications, broadcast services, as well as other communication services.

Synchronization technology is implemented for a satellite communication system. Master clock information is accessed at a terrestrial location. A timing message based on

the master clock information is transmitted from the terrestrial location to a satellite as the satellite is in orbit. The satellite is synchronized to the master clock based on the timing message. A beacon signal is transmitted from the satellite toward Earth. The beacon signal includes timing information. The beacon signal is received at a ground based gateway. The gateway is synchronized to the satellite based on the beacon signal. Communication is sent from the gateway to a terminal via the satellite. The communication includes timing data. The terminal is synchronized to the gateway based on the timing data.

FIG. 1 is a block diagram depicting a portion of a satellite communications system that includes one or more satellites. FIG. 1 depicts satellite 201, which is a non-geostationary satellite. A geostationary satellite moves in a geosynchronous orbit (having a period of rotation synchronous with that of the Earth's rotation) in the plane of the Equator, so that it remains stationary in relation to a fixed point on the Earth's surface. This orbit is often achieved at an altitude of 22,300 miles (35,900 km) above the earth; however, other altitudes can also be used. A non-geostationary satellite is a satellite that is not a geostationary satellite and is not in an orbit that causes the satellite to remain stationary in relation to a fixed point on the Earth's surface. Examples of non-geostationary satellites include (but are not limited to) satellites in Low Earth Orbits ("LEO"), Medium Earth Orbits ("MEO") or Highly Elliptical Orbits ("HEO"). Although FIG. 1 only shows one satellite, in some embodiments (as described below) the system will include multiple satellites that are referred to as a constellation of satellites.

In one embodiment, satellite 210 comprises a bus (i.e., spacecraft) and one or more payloads, including a communications payload. The satellite may also include multiple power sources, such as batteries, solar panels, and one or more propulsion systems, for operating the bus and the payload. The satellite includes an antenna system that provides a plurality of beams, including non-articulated and steerable spot beams, for communicating with subscriber terminals and gateways.

A subscriber terminal is a device that wirelessly communicates with a satellite, usually to be used by one or more end users. The term subscriber terminal may be used to refer to a single subscriber terminal or multiple subscriber terminals. A subscriber terminal is adapted for communication with the satellite communication system including satellite 201. Subscriber terminals may include fixed and mobile subscriber terminals including, but not limited to, a cellular telephone, wireless handset, a wireless modem, a data transceiver, a paging or position determination receiver, or mobile radio-telephone, a cellular backhaul, a trunk, an enterprise computing or storage device, an airborne device, a maritime device or a head end of an isolated local network. A subscriber terminal may be hand-held, portable (including vehicle-mounted installations for cars, trucks, boats, trains, planes, etc.) or fixed as desired. A subscriber terminal may be referred to as a wireless communication device, a mobile station, a mobile wireless unit, a user, a subscriber, a terminal or a mobile.

The term gateway may be used to refer to a device that communicates wirelessly with a satellite and provides an interface to a network, such as the Internet, a wide area network, a telephone network or other type of network. In some embodiments, gateways manage the subscriber terminals.

FIG. 1 also shows a Network Control Center 230, which includes an antenna and modem for communicating with satellite 201, as well as one or more processors and data

storage units. Network Control Center **230** provides commands to control and operate satellite communication payload **201**, as well as all other satellite communication payloads in the constellation. Network Control Center **230** may also provide commands to any of the gateways (via a satellite or a terrestrial network) and/or subscriber terminals.

In one embodiment, satellite **201** is configured to provide two hundred fixed (i.e., non-articulated so that they are fixed in relation to satellite **201**) spot beams that use time domain beam hopping among the spot beams. In other embodiments, more or less than two hundred spot beams can be used for the time domain beam hopping. In one embodiment, the two hundred hopping beams are divided into thirty six hopping groups such that one beam in each group is active at a given time; therefore, thirty six of the two hundred spot beams are active at an instance in time. In addition to the two hundred non-articulated spot beams that perform time domain beam hopping, one embodiment of satellite **201** includes eight 4.2 degree steerable spot beams used to communicate with gateways. In other embodiments, more or less than eight can be used. Additionally, satellite **201** includes six 2.8 degree steerable spot beams which can have a dual purpose of communicating with gateways and/or providing high capacity communication for subscriber terminals that would otherwise fall under the hopping beams of the two hundred spot beams performing time domain beam hopping. Other embodiments can use different sized spot beams.

For example purposes only, FIG. **1** shows five spot beams: **202**, **206**, **210**, **214** and **218**. Spot beam **202** is a 4.2 degree steerable spot beam that illuminates coverage area **204** for communicating with one or more gateways **205** via downlink **202d** and uplink **202u**. Spot beam **206** is a 2.8 degree steerable dual purpose beam that illuminates coverage area **208** in order to communicate with one or more gateways **209** and one or more subscriber Terminals ST via downlink **206d** and uplink **206u**. Spot beam **210** is a 2.8 degree steerable spot beam that could be used to communicate with gateways and/or subscriber terminals ST, but in the example of FIG. **1** spot beam **210** illuminates coverage area **212** to communicate with one or more gateways **213** via downlink **210d** and uplink **210u**. The two hundred spot beams that perform time domain beam hopping can be used to communicate with subscriber terminals and/or gateways. Spot beams **214** and **218** are two examples of the two hundred non-articulated spot beams that performed time domain beam hopping. Spot beam **214** illuminates coverage area **216** to communicate with one or more gateways **217** and one or more subscriber terminals ST via downlink **214d** and uplink **214u**. Spot beam **218** illuminates coverage area **220** to communicate with subscriber terminals ST via downlink **218d** and uplink **218u**.

FIG. **2** is a block diagram depicting more details of one embodiment of an antenna system of satellite **201**. For example, FIG. **2** shows antennas **252**, **254**, **258** and **260** which provide the two hundred spot beams that implement time domain beam hopping. Each of antennas **252**, **254**, **258** and **260** provide fifty spot beams each. FIG. **2** shows feed cluster **262** pointed at antenna **252**, feed cluster **264** pointed at antenna **254**, feed cluster **266** pointed at antenna **258** and feed cluster **268** pointed at antenna **260**. Additionally, satellite **201** includes six 2.8 degree steerable antennas for communicating with gateways and/or providing high capacity beams for subscriber terminals, including antennas **286**, **288**, **290**, **292**, **294** and **296**. Satellite **201** also includes eight 4.2 degree steerable antennas for communicating with gateways, including antennas **270**, **272**, **274**, **276**, **278**, **280**, **282** and **284**. In one embodiment, the antennas are mechanically

steerable. In another embodiment, a phased array or other means can be used to electronically steer the spot beams. Satellite **201** also includes an antenna **298** for communicating with network control center **230** in order to provide telemetry and commands to satellite **201**, and provide status and other data back to network control center **230**.

Antenna **298**, or any of the other antennas, can also be used to provide a beacon signal. In some embodiments, satellite **201** can include an additional antenna for providing the beacon signal. In traditional satellites, the beacon signal provides subscriber terminals and gateways with a gauge to determine how much power should be used. A terminal on the ground can transmit a signal which the satellite will use to generate a corresponding downlink, which can then be compared to the strength of the beacon signal, and then can adjust its power up or down to match the beacon signal. The beacon signal can also be used to determine when a satellite is not operational. Additionally, beacon signals can be used to compensate for Doppler shift. Since the terminals knows the beacon is supposed to be on a certain frequency, it can calculate its Doppler based on the current reception of the beacon signal.

FIG. **3** provides an example beam map for the two hundred non-articulated spot beams of satellite **201** that implement time domain beam hopping. In one embodiment, those spot beams are fixed in direction, relative to satellite **201**. As can be seen, the two hundred spot beams depicted in FIG. **3** are numbered 1-200. In one embodiment, the spot beams overlap; for example, the -5 dB contour of each spot beam overlaps with the -5 dB contour of other spot beams neighboring it. All the spot beams together comprise the Field of Regard of satellite **201**. The Field of Regard of the satellite is different than the Field of View of the satellite. For example, the Field of Regard is the target area that the satellite can see/communicate based on its position. Thus, the entire beam map of FIG. **3** is the Field of Regard. In contrast, the Field of View is the area that the satellite's payload can actually see at an instance in time. For example, when performing time domain beam hopping, only a subset of those spot beams depicted in FIG. **3** are active at a given time. Therefore the Field of View is less than the Field of Regard.

In one embodiment, satellite **201** is only one satellite of a larger constellation of satellites that implement the satellite communication system. In one example embodiment, the satellite constellation includes eleven satellites, with each satellite having the same structure as satellite **201**. However, each of the satellites can be independently programmed to implement the same or different time domain beam hopping plans, as will be explained below. FIG. **4** is a map of the world showing eleven MEO satellites **302**, **304**, **306**, **308**, **310**, **312**, **314**, **316**, **318**, **320**, and **322**. In one embodiment, all eleven satellites are in orbit about the Equator. In one example, all eleven satellites are moving in the same orbital direction along the same orbital path and are equally spaced apart from each other. Because the satellites are in MEO orbit, they are non-geostationary, meaning that they will move with respect to any location on the Earth. As the satellites move in orbit, the user and gateway spot beams' coverage areas will drift across the Earth's surface with the satellites. In one example, there will be a drift rate of 360 degrees longitude every six hours, or one degree per minute. In such embodiment, each satellite will orbit past the same earth position in six hours, or four times a day. In one embodiment, the time it takes to drift the width of a spot

beam covering subscriber terminals (one of the two hundred beam hopping spot beams) is approximately 2.8 minutes (168 seconds).

FIG. 5 shows the same map of the world as FIG. 4, with the beam maps (the Field of Regard) for each of the satellites depicted over the map. For example, satellite 302 projects beam map 350, satellite 304 projects beam map 352, satellite 306 projects beam map 354, satellite 308 projects beam map 356, satellite 310 projects beam map 358, satellite 312 projects beam map 360, satellite 314 projects beam map 362, satellite 316 projects beam map 365, satellite 318 projects beam map 366, satellite 320 projects beam map 368, and satellite 322 projects beam map 370. Note that the satellites 302-322 are constantly moving west to east; therefore, beam maps 350-370 are also moving west to east, and are never stationary (in one embodiment). As can be seen, adjacent satellites have adjacent beam maps and adjacent Fields of Regard when operating the satellites. In one embodiment, the beam maps of adjacent satellites overlap so that among the constellation's satellites there is continuous coverage around the globe; however, there may be gaps in coverage at the north and south poles (where there is little demand). That is, the beam map of each satellite is adjacent to a beam map on the adjacent satellite to provide a composite beam map that circumnavigates the Earth.

FIG. 6 is a block diagram of one embodiment of a communications payload for non-geostationary satellite 201. In one embodiment, each of satellites 302-322 implement the same structure and design of satellite 201; therefore, the payload of FIG. 6 will be implemented on each of satellites 302-322. Traditionally, the communications path from the gateway to the subscriber terminal via the satellite is referred to as the forward path and the communications path from the subscriber terminals to the gateway via the satellite are referred to as the return path. When a satellite is used to provide connectivity to the Internet, a user at a computer connected to a subscriber terminal will send a request for content on the Internet to the gateway via the satellite, and the gateway will provide, in response to that request, access onto the Internet. The response from the Internet will be provided to the gateway, and then forwarded onto the subscriber terminal via the satellite.

The structure of FIG. 6 implements both the forward path and the return path. The uplink beams are received at the left hand portion of the components of FIG. 6 and the downlink beams are provided at the right hand edge of the components of FIG. 6. For example, FIG. 6 shows eight gateway steerable dual polarization antennas 400 and six gateway/high capacity subscriber terminal steerable antennas with dual polarization 402 for receiving uplink beams. FIG. 6 also shows the two hundred non-articulated spot beams divided into two groups: one hundred and seventy spot beams 404 illuminating areas away from the Equator and thirty spot beams 406 illuminating areas at the Equator.

The eight 4.2 degree gateway steerable spot beams 400 provide sixteen signals, eight in each polarization (left hand/right hand or horizontal/vertical). Six of those sixteen signals are provided to selection matrix 410 which includes a set of switches that selects two of the six input signals and provides those two selected signals to low noise amplifier 412. Ten of the 16 dual polarization signals from antennas 400 are applied directly to low noise amplifier bank 412 comprising low noise amplifiers. Note that the antennas 400 of FIG. 6 correspond to antennas 270-284 of FIG. 2. Similarly, antennas 402 of FIG. 6 correspond to antennas 286-296 of FIG. 2. The six gateway steerable antennas 402 provide 12 signals (six signals in two polarizations). Six of

those signals are provided directly to low noise amplifier bank 412, the other six signals are provided to a 6:2 selection matrix 414, which chooses two of the signals to provide to low noise amplifier bank 412. Note that the satellite payload will include a processor (not depicted) which controls each of the selection matrices described herein. Alternatively, satellite bus will include a processor that will control the selection matrices. As described above, low noise amplifier bank 412 has 20 input signals and, therefore has 20 output signals. Fourteen of the signals output from low noise amplifier bank 412 are provided to separate splitters 416. That is, there are 14 splitters 416. Each splitter splits the incoming signal into four copies noted as: F1/3, F2/4, F5/6 and F7/8. The other six outputs from LNA 412 are provided to a different set of splitters 418 that split the signal to four copies labeled as: F1/3, F2/4, F7/8 and R-HC. The seven outputs of the splitter that started with an F are part of the forward path. The one output of the splitter 418 that is labeled R-HC is part of the return path from a steerable high capacity spot beam used to connect to subscriber terminals. In one embodiment splitters 416 and 418 include filters for passing the frequency bands of the labeled output and stopping all other frequencies.

After the splitters 416 and 418, the signals are sent to appropriate matrices 420, 422, 424, 426 and 428 in order to select which bands to use. Selection matrix 420 receives the signal F1/3. Selection matrix 422 receives signal F2/4. Selection matrix 424 receives signal F5/6. Selection matrix 426 receives signal R-8C. Selection matrix 428 receives F7/8. Eleven signals of the output of selection matrix 420 are provided to down converter 440, which provides its output to channel 442. The 11 signals of the output of selection matrix 422 are provided to down converter 444, which provides its output to channelizer 442. The output of selection matrix 424 includes seven signals that are provided to down converter 446, which provides its output to channelizer 442. The output of selection matrix 426 includes six signals that are provided to down converter 446, which provides its output to channelizer 442. The output of selection matrix 428 includes 11 signals that are provided to down converter 448, which provides its output to channelizer 442. Each of the selection matrices includes a series of programmable switches to route a subset of inputs to the output ports.

The one hundred and seventy non-Equatorial spot beams 404 are provided to selection matrix 443 which chooses twenty eight out of the one hundred and seventy spot beams. That is, one beam from each of 28 beam hopping groups (discussed below) is chosen. Those 28 signals are sent to low noise amplifier 444. Half of the signals output from low noise amplifier 444 are provided to splitters 446. The other half of the signals are provided to splitters 448. Each of the fourteen splitters 446 make three copies of the signal and output those three copies as F1/3, F2/4 and RTN. Each of the fourteen splitters 448 make three copies of their respective incoming signals and output them F5/6, F7/8 and RTN. Note that the signals F1/3, F2/4, F5/6 and F7/8 are part of the forward path representing communication from a gateway in one of the one hundred and seventy hopping beams. The signal RTN is part of the return path, from subscriber terminals. Note that in some embodiments, each of the splitters has appropriate band pass filters. In some embodiments, each of the selection matrices has appropriate band pass filters at respective inputs and/or outputs.

FIG. 6 shows the thirty non-articulated beam hopping spot beams near the Equator being provided to selection matrix 454. The eight selected signals are provided to low

noise amplifier **456** which outputs a signal labeled RTN. Note in some embodiments, each of the low noise amplifiers **456**, **444** and **412** have band pass filters at their input and/or output. Additionally, band pass filters can be used at each of the antennas **400**, **402**, **404** and **406**. Based on the output of splitters **448** and low noise amplifier **456**, thirty six signals labeled RTN are frequency combined in MUX **450** which outputs 9 signals. The output of MUX **450** is provided to down converter **452**. The output of down converter **452** is provided to channelizer **442**. Each of the selection matrices **410**, **414**, **420**, **422**, **424**, **426**, **428**, **443** and **454** includes switches that are used to switch throughput among the various spot beams in the hopping groups or among various bands from the gateways and high capacity steerable spot beams. The chosen signals are provided to channelizer **442** which is used to route spectrum between the uplinks and downlinks. In one embodiment, channelizer **442** is a digital channelizer that is fully programmable in orbit. More details of channelizer **442** are provided below with respect to FIG. **7**. Channelizer **442** can be thought of as a giant switching or routing matrix that is fully programmable. FIG. **6** shows that channelizer **442** provides fourteen outputs to upconverter **460**, fourteen outputs to upconverter **472**, eight outputs to upconverter **480**, eight outputs to upconverter **490** and twenty outputs to upconverter **502**. Note that upconverters **460**, **472**, **480** and **490** (all which function to increase the frequency of the signal) are provided as part of the forward path, while upconverter **502** is provided for the return path. The output of each of the 14 up converters **460** are provided to filters **462**. The output of each of the fourteen filters **462** are provided to solid state power amplifiers (SSPA) **464**. The output of each of the fourteen SSPAs are provided to multiplexer **466**. The output of multiplexer **466** is provided to 28:170 selection matrix **468**. The 170 outputs of selection matrix **468** are provided as the one hundred and seventy non-Equatorial non-articulated beam hopping spot beams **470**.

The output of the fourteen upconverters **472** are provided to separate filters **474**. The output of each of the fourteen filters **474** is provided to separate SSPAs **476**. The output of each of the fourteen SSPAs **476** are provided to multiplexer **478**. The output of multiplexer **478** is provided to selection matrix **468**. The output of the eight upconverters **480** are provided to filters **482**. The output of the eight filters **482** are provided to separate SSPAs **484**. The output of SSPAs **484** are provided to selection matrix **486**. The output of selection matrix **486** is provided as the thirty Equatorial region non-articulated beam hopping spot beams of **488**. Note that the SSPAs can be turned off (e.g., when the satellite is over the ocean or other non-inhabited area) to conserve power.

The output of upconverters **490** (which can be part of the forward path or the return path) are provided to filters **492**. The output of the eight filters **492** are provided to SSPAs **494**. The output of the eight SSPAs **494** are provided to selection matrix **496**. The 12 output signals from selection matrix **496** are provided to multiplexer **498**. The output of multiplexer **498** are provided as the six 2.8 degree gateway/high capacity subscriber terminals steerable spot beams, with dual polarization.

The output of upconverters **502** are provided to separate filters **504**. The output of the twenty filters **504** are provided to separate SSPAs **506**. The output of the 20 SSPAs **506** are provided to selection matrix **508**, which provides 42 outputs. Twelve of the 42 outputs are provided to multiplexer **498**, fourteen of the 42 outputs are provided to multiplexer **466**

and multiplexer **478**, and sixteen of the 42 outputs are provided as the eight gateway steerable dual polarization spot beams described above.

In an alternative embodiment, many or all of the selection matrices can be eliminated by having the selection/switching performed by channelizer **442**. In some embodiments, the payload of FIG. **6** can be fully implemented by just a channelizer that will switch, route and filter.

FIG. **7** is a block diagram describing one example implementation of channelizer **442**. The technologies described herein are limited to any one particular architecture or implementation of channelizer **442**. The embodiment of FIG. **7** is only one example that is suitable for the technology described herein and many other configurations are also usable. Inputs to channelizer **442** are provided to a receive module **550**, where signals can be filtered, amplified, stored or simply received. The output of receive module **550** is provided to switch network and beam forming network **552**. The output of switch network and beam forming network **552** is provided to a transmission module **554** which provides the outputs of channelizer **442**. Channelizer **442** also includes an auxiliary module **556**, control unit **558** and clock generator **560**, which are all connected to receive module **550**, switch network/beam forming network **552** and transmission module **554**. In one embodiment, control unit **558** includes one or more processors used to program the switch networks/beam forming network **552**. Clock generator **560** provides a clock signal to implement timing within channelizer **442**. In one embodiment, auxiliary module **556** is used to control the switches of the switching network, adjust beams, provide spectrum analysis and provide uplink and downlink modems.

In one embodiment, each of the non-geostationary satellites **302-322** are configured to provide a plurality of spot beams (described above) that implement a first frequency plan at the Earth's Equator and a second frequency plan away from the Earth's Equator, with the first frequency plan being different than the second frequency plan. Thus, when operating the constellation of non-geostationary satellites, multiple or all of those satellites within the constellation will communicate with a terminal or multiple terminals at the Equator using spot beams to implement the first frequency plan and multiple or all of the satellites of the constellation will communicate with a different terminal(s) that is away from the Equator using spot beams that implement the second frequency plan.

In one embodiment, the frequency plans at the Equator and away from the Equator are both using the KA band; however, other bands can also be used. FIGS. **8** and **9** provide the frequency plan for the areas away from the Earth's Equator, while FIGS. **11** and **12** provide the frequency plan for the areas at the Equator. More specifically, FIG. **8** provides the frequency plan away from the Equator for uplinks. FIG. **8** shows the uplink using between 27.50 GHz through 30.00 GHz. The frequency plan includes three components. The first component is the forward uplink utilized by gateways including eight colors (frequency band plus polarization) each comprising a 500 MHz frequency band in one polarization (left hand circular polarization LHCP or right hand circular polarization RHCP) labeled as FWD1 UL, FWD2 UL, FWD3 UL, FWD4 UL, FWD5 UL, FWD6 UL, FWD7 UL, FWD8 UL. The second component of FIG. **8** includes the return path used by subscriber terminals which includes eight colors each of which is a frequency band of 100 MHz in one polarization labeled as R1, R2, R3, R4, R1a, R2a, R3a, and R4a. FIG. **8** also shows frequency plan for the return path used by subscriber ter-

11

minals in the high capacity steerable beams which comprise four colors each of which is a frequency band of 225 MHz and one polarization (LHCP or RHCP), labeled as R1 HC UL, R2 HC UL, R3 HC UL and R4 HC UL. The arrow labeled TC indicates the frequency assigned for Telemetry and Control signals.

FIG. 9 shows the frequency plan for the downlink in the regions away from the Equator. The frequency plan for communicating downlink beam to the subscriber terminals uses four colors each with a 500 MHz frequency band in one polarization (LHCP or RHCP) labeled as FWD D1 DL, FWD D2 DL, FWD D3 DL and FWD D4 DL. As mentioned above, the 170 non-articulated spot beams that implement time domain beam hopping can also serve gateways and do so using four colors each of which are 180 MHz frequency bands in one polarization and labeled in FIG. 9 as R1 FB DL, R2 FB DL, R3 FB DL and R4 FB DL. As discussed above, the satellite can include high capacity steerable beams that can service both gateways and subscriber terminals. The downlink to the subscriber terminals in those high capacity steerable beams use four colors each with 400 MHz frequency band in one polarization that are labeled in FIG. 9 as FWD HC1 DL, FWD HC2 DL, FWD HC3 DL, and FWD HC4 DL. As discussed above, the satellite can include 4.2 degree steerable spot beams that communicate with gateways. Those beams will utilize two colors, each which includes 400 MHz frequency band in one polarization and composed of 8 sub channels that are labeled in FIG. 9 as R1, R2, R3, R4, R1a, R2a, R3 and R4a. When the high capacity steerable beams are utilized, the downlink can also be part of the 4.2 degree steerable spot beams return path and includes a 225 MHz frequency band in one polarization, within the 400 available spectrum and labeled R1/2/3/4 HC DL. Note that in one embodiment, frequency plan for the uplink and the downlink are constructed such that the subscriber terminals and the gateways use different frequencies. When a particular spot beam of the of spot beams performing time domain beam hopping serves a gateway and subscriber terminals then the subscriber terminals and the gateway use different frequencies. The arrow labeled TM (which can be in-band or out of band) represents Telemetry and Control Signals. Note that while the example embodiment depicted in FIGS. 8 and 9 shows the two polarizations as left hand circular polarization LHCP or right hand circular polarization RHCP, other embodiments can use left hand or right hand polarizations whet her it is circular or linear. Some embodiments of satellite communication systems use vertical and horizontal polarization.

FIG. 10 is a beam map that shows the same Field of Regard as FIG. 3, and, therefore, the same beam map as FIG. 3. However, instead of showing numbers in each of the spot beams on the beam map, FIG. 10 shades each beam. The shading of FIG. 10 corresponds to the shading in FIG. 9. Thus, each of the spot beams is assigned a downlink color (frequency band and polarization) using the frequency plan of FIG. 9. For example, the bottom left hand most beam in row one has vertical shading and therefore corresponds to FWD D3 DL and the uppermost right hand beam in row 22 has angled shading which corresponds to FWD D1 DL. FIG. 10 shows a four color reuse plan.

FIGS. 11 and 12 show the frequency plan for the area at the Equator. In one embodiment, different frequency plans are used at the Equator because there is a need to avoid interference with geostationary satellites. FIG. 11 depicts the frequency plan for the uplink. In one embodiment, none of the steerable spot beams will be used in the area near the Equator. Therefore, the area near the Equator will only be

12

serviced by non-articulated spot beams that are implementing time domain beam hopping. The uplink in the Equator area will include eight colors, each of which has a frequency band of 100 MHz in one polarization so that four colors are left hand polarized and between 28.60 GHz and 29.10 GHz. The eight colors of the uplink in the Equator region are labeled as R1, R2, R3, R4, R1a, R2a, R3a, and R4a. Each of these frequency bands are used as part of the return path implementing communication from subscriber terminals toward the satellite.

FIG. 12 shows the frequency plan for the downlink in the area of the Equator and represents four colors used for the forward downlink. Each of the colors includes frequency bands that are 250 MHz in one polarization, labeled as FWD E1, FWD E2, FWD E3, and FWD E4. The four colors range between 18.80 GHz and 19.3 GHz.

So differences in the downlink at the Equator versus away from the Equator includes away from the non-Equator downlink colors having twice as big frequency ranges. For example, FWD D1 DL is 500 MHz between 18.8 and 19.3 GHz versus FWD E1 being 250 MHz between 18.8 and 19.05. FWD D2 DL is 500 MHz between 19.3 and 19.8 GHz versus FWD E2 being 250 MHz between 19.05 GHz and 19.3 GHz; FWD D3 DL is 500 MHz between 18.8 and 19.3 GHz while FWD E3 is 250 MHz between 18.8 and 19.05 GHz; and FWD D4 DL is 500 MHz between 19.3 and 19.8 GHz versus FWD E4 being 250 MHz between 19.05 and 19.3 GHz. While the return links in the Equator and non-Equator are both 100 MHz bands, the frequency bands for the Equator region are shifted up in frequency; for example, R1 in FIG. 8 starts at 28.54 GHz while R1 in FIG. 11 starts at 28.6 GHz.

As can be seen from FIGS. 8, 9, 11 and 12, the frequency plan away from the Equator includes frequency ranges not in the frequency plan at the Equator; the frequency plan at the Equator includes different uplink frequency ranges than the second frequency plan; the frequency plan away from the Equator includes larger frequency ranges than frequency plan at the Equator; the frequency plan away from the Equator includes more frequency ranges than the frequency plan at the Equator; and the frequency plan away from the Equator includes more bandwidth than the frequency plan at the Equator. The spot beams at the Equator consist of only non-articulated spot beams relative to the satellite and the spot beams away from the Equator include non-articulated spot beams relative to the satellite and steerable spot beams.

When operating the constellation of non-geostationary satellites 302-322, multiple satellites of the constellation communicating with a first terminal at the Equator use spot beams that implement the frequency plan for the Equator and multiple satellites of the constellation communicating with a second terminal away from the Equator use spot beams that implement the frequency plan for regions away from the Equator (e.g., using adjacent Fields of Regard for the satellites of the constellation).

FIG. 13 shows the same Field of Regard and same beam map as FIG. 3 and FIG. 10; however, FIG. 13 graphically depicts the Equator zone and the non-Equator zone (away from the Equator). With the Equator zone corresponds to the frequency plan of FIGS. 11 and 12 and the non-Equator zone corresponds to the frequency plan of FIGS. 8 and 9. Note that FIG. 13 uses shading for the Equator zone. If the rows of the beams in the beam map of FIGS. 3, 10 and 13 were to be numbered, as depicted in FIGS. 10 and 13, rows 10, 11 and 12 refer to the Equator zone. Note that FIG. 12 uses shading for the four colors of the frequency plan. This

shading is also used to assign each of the colors to the various spot beams in the Equator zone as depicted in FIG. 10.

FIG. 13A is flowchart describing one embodiment of a process for operating a constellation of satellites that use different frequency plans and different hopping plans (described below) between spot beams at the Equator and spot beams away from the Equator. In step 580, the system operates the constellation of non-geostationary satellites in an orbit at the Equator. In other embodiments, other orbits can be used. In step 582, each satellite of the constellation provides a first set of spot beams that illuminate a region over the Equator using a frequency plan for the Equator, for example, the frequency plan of FIGS. 11 and 12. In step 584, each satellite of the constellation provides a second set of spot beams that illuminates a region away from the Equator using a frequency plan for non-Equatorial areas. For example, step 584 can include using the frequency plans of FIGS. 8 and 9 in the non-Equator zone of FIG. 13. Step 582 can include using the frequency plans of FIGS. 11 and 12 in the Equator zone of FIG. 13. In step 586, each of the satellites of the constellation flies over a terminal at or near the Equator as it is traversing along its orbital path along the Equator. As it flies over that terminal, it communicates with that terminal using the first set of spot beams and the frequency plan for the Equator. In step 588, as each satellite of the constellation flies over a terminal in a region away from the Equator, it communicates with that terminal using the second set of spot beams and the frequency plan for non-Equatorial areas (e.g., the non-Equator zone). As discussed above, each of the 11 satellites of the example constellation depicted in FIG. 4 traverse over the same orbit four times a day and thus each of the satellites will have an opportunity to communicate with each terminal potentially four times a day (if that terminal is stationary and always on), using the appropriate Equator zone or non-Equator zone frequency plan. The process of FIG. 13A is not necessarily performed in the order or sequence depicted in FIG. 13A, and other sequences can be implemented. For example, step 580 can be thought of as summarizing the whole operation of the system and can encompass all other steps, steps 582 and 584 can be performed in parallel, and steps 582 and 584 can be performed in parallel.

As discussed above, the high capacity steerable beams can provide service to subscriber terminals as well as gateways. The satellites can support full mesh networks between subscribers terminals in high capacity steerable beams. For example, two subscriber terminals in a same high capacity steerable beam can communicate with each other directly via the satellite without going through a gateway. Additionally, two subscriber terminals in a different high capacity steerable beams can communicate with each other directly via the satellite without going through a gateway. These subscriber terminals in high capacity steerable beams and the high capacity steerable beams are not performing time domain beam hopping. Additionally, gateways can communicate with subscriber terminals in the high capacity beams without using time domain beam hopping. Another embodiment is to configure beam assignments in the articulated array such that continuous connectivity is provided to geographic locations, such that no beam hopping is required by either the gateway or subscriber terminals in either feeder or subscriber uplinks.

Single Polarity Across Path of Spot Beams

As the 11 satellites 302-322 travel along their orbital path west to east at the Equator, the spot beams (including the entire Field of Regard) will move over the Earth's surface

from west to east. As the spot beams move over a subscriber terminal, that subscriber terminal will first connect with an eastern spot beam in the Field of Regard and then slowly move towards the western spot beams as the spot beams as a whole (see FIG. 3) move west to east. For example, a subscriber terminal may first connect to spot beam 199. Subsequently, the subscriber terminal will move through spot beams 129, 130, 131, 132, 133, 134, 135, 136 and then 137.

In one embodiment, each of the non-geostationary satellites 302-322 provide the plurality of spot beams (e.g., the beam map in Field of Regard of FIG. 3) to use multiple frequencies and multiple (e.g., two) polarities, such that all spot beams along a path completely across the plurality of spot beams in the orbital direction communicate using a common polarization. In the above-described example, the path completely across the plurality of spot beams was from spot beam 199 to spot beam 137. That path is in the orbital direction because the satellite is traveling west to east along the Equator. In this embodiment, all the spot beams in the path across beams 199, 129, 130, 131, 132, 133, 134, 135, 136 and 137 are configured to have the same polarity. This way, as the Field of Regard travels over and past a subscriber terminal, that subscriber terminal will not need to change polarities as it hands over between spot beams or between satellites. It may be that the subscriber terminal may have to change frequencies when it changes spot beams but it will not need to change polarities. This is more graphically depicted in FIG. 14A which shows a Field of Regard (or a portion of a Field of Regard), including a polarity of spot beams. In each spot beam, there is an L or an R to indicate whether the spot beam has left hand polarization or right hand polarization. Arrow 573 depicts a path completely across the plurality of spot beams in the orbital direction and shows an example of how that path will only traverse across spot beams having left hand polarization.

FIG. 14B shows another embodiment of a plurality of spot beams where the path completely across the plurality of spot beams in the orbital direction is on a diagonal, as indicated by arrow 575. Arrows 573 and 575 of FIGS. 14A and 14B indicate the path that a subscriber terminal will take as the subscriber terminal is stationary and the spot beams traverse over or pass the subscriber terminal. Note that the technology described herein can be used with equatorial orbits and non-equatorial orbits (orbits that do not follow the equator), including elliptical orbits.

FIGS. 15A-F provides another example of a subscriber terminal traversing completely across the plurality of spot beams in the orbital direction using a single polarization. For example, in FIG. 15A, spot beams 1-11 are depicted. Next to each spot beam number is an L or an R indicating whether it is left hand polarization or using right hand polarization. The initial position of the subscriber terminal is indicated by "S." As seen in FIG. 15A, the Field of Regard is due west of the subscriber terminal S. As also seen in FIG. 8, each spot beam is configured to communicate in at least one frequency range and one polarity. Polarizations are assigned to the spot beams such that all spot beams that illuminate and are configured to communicate with the subscriber terminal S on a ground location use a same polarity, while other spot beams in the Field of Regard that do not illuminate subscriber terminal S can use another polarity. For example, FIGS. 15B-F shows the Field of Regard moving west to east. In FIG. 15B, the Field of Regard has moved such that subscriber terminal S is now within spot beam 7 and communicating with spot beam 7 using right hand polarization. Meanwhile, spot beams 1, 2, 3 and 8-11 communicate

15

with other subscriber terminals using left hand polarization. In FIG. 15C, the Field of Regard has moved such that the subscriber terminal S is communicating with spot beam 6, also using right hand polarization. In FIG. 15D, the Field of Regard has moved such that subscriber terminal S is not in communication with spot beam 5, using right hand polarization. In FIG. 15E, the Field of Regard has moved such that subscriber terminal S is in communication with spot beam 4, using right hand polarization. In FIG. 15F, the Field of Regard has moved east of subscriber terminal S and therefore subscriber terminal S is no longer in communication with any of the spot beams or the Field of Regard depicted in FIG. 15F. As can be seen, as the spot beams traversed across or past subscriber terminal S, subscriber terminal S continued to only communicate using right hand polarization. In one embodiment, each spot beams 4, 5, 6 and 7 use different frequency bands. In other embodiments, spot beams 5 and 7 can use the same frequency band, and spot beams 4 and 6 can use the same frequency band. Therefore, as the Field of Regard traverses over or passed the subscriber terminal, the subscriber terminal will need to change frequencies between spot beams but will not change polarizations. Not changing polarization makes the handover process faster and allows the subscriber terminal to be a simpler less expensive design.

FIG. 15G is a flowchart describing one embodiment of a process for operating a subscriber terminal, including changing frequencies for subscriber terminals without the need to change polarization as the satellite moves with respect to the subscriber terminal. In step 602, the subscriber terminal communicates with the current satellite using the current spot beam at a current frequency and fixed polarization while the current satellite moves in orbit. Step 602 is continued to be performed until the subscriber terminal comes to the edge of the spot beam. At that point a handover must take place to the next spot beam. It is determined whether the next spot beam is in a new satellite or in the current satellite (step 604). If not in a new satellite (therefore, in the current satellite), then the subscriber terminal automatically change its communication frequency to a frequency used for the next adjacent spot beam on the current satellite, with no change to polarization (step 606). The process will then continue at step 602. However, if the next adjacent spot beam is for a new satellite (step 604), then in step 610, the subscriber terminal automatically changes communication frequency to the frequency for the first spot beam on the next satellite, with no change to polarization. Thus, even as the subscriber terminal hands off from satellite to satellite, it will not need to change polarization. Thus, the subscriber terminal will maintain one polarization across the path of spot beams even over multiple satellites. In step 612, the subscriber terminal will establish communication with the next satellite and the next satellite will then become the current satellite. After step 612, the process moves back to step 602.

FIG. 15H is a flowchart describing one embodiment of a process for operating a satellite communication system, including implementing handovers between spot beams such that a subscriber terminal does not need to change polarities for the handover. The process of FIG. 15H is performed by a non-geostationary satellite orbiting the Earth that is configured to provide a plurality of spot beams in the Field of Regard, where the plurality of spot beams use multiple frequencies and multiple polarities, each spot beam of the plurality spot beam is configured to communicate in at least one frequency range and polarity. The satellite will communicate with a terminal using different spot beams and

16

a common polarity while the terminal is within the Field of Regard as the first non-geostationary satellite moves relative to the Earth and the terminal changes spot beams. For example, in step 640, the satellite will communicate with a subscriber terminal (ground or airborne location) using the current spot beam and the common polarity for the path that that subscriber terminal will take across the Field of Regard. In step 642, it is determined whether the satellite has moved too far such that the subscriber terminal will no longer be in the current spot beam. If not, the process will continue in step 640. If, however, the satellite has moved too far such that the subscriber terminal is at the edge of a spot beam, it is next determined whether the subscriber terminal is at the edge of the beam map (step 644). If the subscriber terminal is not at the edge of the beam map, then the subscriber terminal will be handed over to the next adjacent spot beam in the orbital direction that uses the same common polarity in step 646. Subsequently, the process will continue in step 640. If, however, the subscriber terminal was at the edge of the beam map, then in step 648, the subscriber terminal will be handed over to a spot beam on the adjacent satellite, also using the same common polarity that the subscriber terminal has been communicating with.

Beam Hopping

As described above, each of satellites 302-322 are non-geostationary satellites configured to provide a plurality of spot beams using time domain beam hopping among the spot beams. In one embodiment, time domain beam hopping includes multiple spot beams sharing frequency bandwidth or throughput such that different spot beams can use the same frequency bandwidth or throughput at different times because the shared bandwidth or throughput hops between spot beams with only a subset of spot beams being active at a time. Thus, the satellite is configured to switch throughput among spot beams in a same hopping group. The time domain beam hopping allows the Field of Regard to be much bigger than without using time domain beam hopping. That is, the satellite can have a much wider coverage area.

One of the challenges of time domain beam hopping with a non-geostationary satellite is that the coverage area is constantly changing. In addition, over time demand for services changes. Thus there are two changing variables demand and coverage area, which complicates the task of designing a non-geostationary satellite communication system.

To implement the time domain beam hopping, the two hundred non-articulated spot beams of the satellite are divided up into beam hopping groups. Each beam hopping group includes multiple spot beams. At any instance in time, only one beam (or a subset of one or more beams) of a hopping group will be active, while the other beams of the hopping group will be inactive. In one embodiment, all beams of the hopping group utilize the same frequency and polarization. In another embodiment, the beams of a hopping group use the same frequency but mix polarizations. The system will create the notion of a hopping period divided into a number of intervals called epochs. Each beam will be assigned one or more epochs during the hopping period. By assigning different numbers of epochs to different spot beams allows the dwell time to vary among spot beams in a hopping group. In some embodiments, the hopping plans consider the revisit time that the particular application needs. For example, voice over IP may need twenty to thirty millisecond revisits to prevent a degradation in quality.

The hopping groups can be assigned to spot beams based on many different strategies. In one example, all the beams of a hopping group are next to each other. For example, FIG.

16A shows a portion of the Field of Regard of FIG. 3, including 25 spot beams divided into five hopping groups of five spot beams each. Each of the hopping groups is shaded using a different type of shading. Hopping group 1 includes beams 3, 4, 5, 11 and 12. Hopping group 2 includes beams 6, 7, 13, 14 and 15. Hopping group 3 includes beams 20, 21, 29, 38 and 39. Hopping group 4 includes beams 22, 30, 31, 40 and 41. Hopping group 5 includes beams 23, 24, 32, 33 and 42. In some embodiments, the hopping plans between hopping groups with spot beam members adjacent to spot beams members of other hopping groups are planned to avoid inter-beam interference

In other embodiments, each of the beams of a hopping group is uniformly or non-uniformly distributed over the Field of Regard. For example, in this embodiment, it is possible that each of the spot beams of a hopping group utilize the same frequency range. The polarization can be different between beams. FIG. 16B shows a portion of the Field of Regard of FIG. 3 including 25 spot beams divided into five hopping groups. Each of the beams of a hopping group is shaded using the same type of shading such that different shading is used for different hopping groups. For example, hopping group 1 includes beams 3, 14, 22, 32 and 38. Hopping group 2 includes beams 4, 14, 21, 33 and 41. Hopping group 3 includes beams 5, 11, 24, 33 and 39. Hopping group 4 includes beams 6, 15, 20, 30 and 42. Hopping group 5 includes beams 7, 13, 23, 29 and 40.

In another embodiment, the hopping groups are arranged consecutively along a path traversed by a subscriber terminal. For example, FIG. 16C shows a portion of the Field of Regard of FIG. 3, with an arrow indicating the orbital direction. Each row of spot beams includes spot beams in the same hopping group. In this embodiment, adjacent rows would have different frequency ranges or different polarizations. In the embodiment of FIG. 16C, hopping group 1 includes spot beams 3, 4, 5, 6 and 7. Hopping group 2 includes beams 11, 12, 13, 14 and 15. Hopping group 3 includes beams 20, 21, 22, 23, and 24. Hopping group 4 includes beams 29, 30, 31, 32 and 33. Hopping group 5 includes beams 38, 39, 40, 41 and 42.

To graphically indicate time domain beam hopping, FIGS. 17A-17E depict five different epochs in a hopping period for the embodiment of FIG. 16B. In each of FIGS. 17A-E, the spot beam that is active for each hopping group is shaded and the spot beams that are inactive for each of the hopping groups are not shaded. In the first epoch, depicted by FIG. 17A, spot beams 4, 11, 22, 29 and 42 are active, while the other spot beams are not active. In the second epoch, depicted in FIG. 17B, spot beams 5, 12, 23, 30 and 41 are active, while the other spot beams are inactive. In the third epoch, depicted by FIG. 17C, spot beams 3, 14, 20, 24, and 40 are active, while the other spot beams are inactive. In the fourth epoch, depicted by FIG. 17D, spot beams 7, 15, 21, 31, and 38 are active, while the rest of the spot beams are inactive. In the fifth epoch, depicted in FIG. 17E, spot beams 6, 13, 32, 33, and 39 are active, while the other spot beams are inactive. It is contemplated that in some embodiments, a hopping period will have more than five epochs. However no specific number of epochs are required in a particular hopping period.

In some embodiments, the hopping period is completely configurable and programmable while the satellites are in orbit. This concept is depicted in FIG. 18 which shows a series of epochs divided into hopping periods. In this embodiment, each hopping period includes N epochs. After N epochs, the next hopping period is performed. In some embodiments, consecutive hopping periods will perform the

same hopping plan (e.g., the same assignment of spot beams to epochs) until a satellite is programmed to change hopping plans (e.g., because demand has changed). During each hopping period, as depicted by FIG. 17A-17E, only one spot beam of each hopping group is active. Therefore, only a portion of the Field of Regard is active. Those spot beams that are active are referred to as the Field of View. As the number of active spot beams is less than the total number of spot beams in the beam map, each of non-geostationary satellites 302-322 has a Field of Regard that is greater than its Field of View at any instance in time.

As discussed above, each of satellites 302-322 provide a plurality of spot beams as the satellites move across the planet surface. In order to perform the time domain beam hopping, the spot beams are divided into hopping groups. The satellite uses the selection matrices described above, in conjunction with the digital channelizer, to perform the time domain beam hopping. FIG. 19 is a flowchart describing one embodiment of a process of a satellite performing the time domain beam hopping. In step 670, the satellite reconfigures the selection matrices to route power and make a connection to the applicable gateway beam to a next set of beams in the hopping groups according to the current hopping plan. In step 672, the satellite will enable communication during epoch 0 (see FIG. 18), only sending power and making gateway connection to the predetermined subset of beams in each group. In step 674, the satellite will reconfigure the selection matrices to route power to the next set of beams in the hopping groups according to the current hopping plan. In step 676, the satellite will communicate during epoch 1, only sending power to a predetermined set of beams in each hopping group according to the hopping plan. In step 678, the satellite will reconfigure the selection matrices to route power to the next set of spot beams in the hopping groups according to the current hopping plan. In step 680, the satellite will enable communication during epoch 2, only sending power to a predetermined subset of beams in each hopping group. This process will continue for each epoch, as depicted in FIG. 18, until the last epoch (designated as epoch N in FIG. 18). In step 682, the satellite will reconfigure the selection matrix to route power to the next hopping group beam sequence according to the current hopping plan. In step 684, the satellite will allow communication during epoch N, only sending power to a predetermined subset of beams in each hopping group. In step 686, the satellite can (optionally) access a new hopping plan that takes into account movement of the non-geostationary satellite. In step 688, the new hopping plan is loaded and becomes the current hopping plan, such that the process continues to step 670. Thus, the process of FIG. 19 describes the operation of the non-geostationary satellite performing time domain beam hopping during a hopping period. In one embodiment, the hopping plan can change at the end of each hopping period. In other embodiments, the hopping plan can change after a fixed number or dynamic number of hopping periods. In other embodiments, the hopping period can change after any hopping period; however, there is no requirement that a hopping plan change after any hopping period.

In one example embodiment, the hopping period is 90 seconds and an epoch is 1.286334 milliseconds. In this embodiment, the time for a spot beam to drift completely across a subscriber terminal is approximately 2 hopping periods (168 seconds).

In one example embodiment that uses time domain beam hopping for the uplink and downlink of the two hundred non-articulated spot beams, the two hundred non-articulated spot beams are divided into thirty six hopping groups.

Twenty-eight of the hopping groups include either six or seven spot beams that are not in the area at the Equator. Eight hopping groups include three or four spot beams that illuminate areas at the Equator. In one embodiment, the assignment of hopping groups is set and unchangeable in the satellites. In other embodiments, the membership of the hopping groups can be changed dynamically in orbit.

In one embodiment, the two hundred non-articulated spot beams are divided into zones so that each hopping group can have one beam in each zone (some hopping groups may have two beams in a zone). In one example embodiment, the non-Equatorial hopping groups will hop across six zones arranged in a north/south grid. This leverages the tendency of each continent's traffic to concentrate along a specific latitude. This also decreases the probability that a heavy demand is needed on one hopping group in two locations and allows hopping groups to concentrate in any large geographic area of high traffic demand. For example, FIG. 20A shows the same Field of Regard as FIG. 3 and indicates the Equator zone (rows 10, 11 and 12). The rest of the Field of Regard, other than the Equator zone, is the non-Equator region. Those spot beams in the non-Equator region are shaded to indicate six zones. Each hopping group will include at least one beam in each zone. FIG. 20B shows the zones for the Equator zone. That is each of the spot beams in the Equator zone is shaded one of four types of shading to indicate which one of the four zones each spot beam is in. Each of the hopping groups for the Equator zone will include no more than one beam in each zone. Thus the Equator zone and the non-Equatorial region have separate zones for forming hopping groups. As such, the beam hopping is performed in the Equator zone differently than the beam hopping in the non-Equatorial region. In one embodiment, a different hopping plan is used for the Equator zone than is used in the non-Equatorial region.

FIG. 21 is a table that shows one example of the 28 hopping groups used for the 170 non-articulated spot beams of the Field of Regard in FIGS. 20A and 20B that are not in the Equator zone. The left hand column indicates the hopping group number HG1-HG28. The other seven columns indicate beam numbers for the beams in the relative hopping group. FIG. 22 is a table describing membership of the hopping groups for the Equator zone. The left hand column indicates the hopping group number EHG1-EHG8 and the other four columns indicate the beam numbers for those beams in the relative hopping groups.

FIG. 23 shows the Field of Regard of FIG. 3 (and FIGS. 20A and 20B) at one epoch. Each of the hopping groups depicted in FIGS. 21 and 22 has one beam active at this particular epoch. Each of the active beams are shaded. Those active beams that are shaded represent the Field of View of the satellite at this epoch. While the entire beam represents the Field of Regard. As can be seen, the Field of Regard for the satellite is greater than the Field of View at this epoch.

FIG. 24 graphically depicts how the epochs are assigned to a set of hopping beams in hopping group HG2 (see FIG. 21) over a portion of the hopping period. As can be seen, at no instance in time is any two beams active in the hopping group. That is only one beam is active at a time; however, the feeder beam which communicates with the gateway that supports beams 2, 24, 56, 79, 131, 154 and 190 is always active at each epoch. That is, at each hop, one source beam and the feeder beam is active for communication. The feeder beam is not part of the hopping group but in some embodiments connectivity to the feeder beam can be changed every hop. Thus, the gateways in the feeder beams are assigned time epochs to manager their terminals within.

FIG. 25 depicts a super-frame which is the data format used during one epoch. In one embodiment, the super-frame is based on the DVB-S2x standard. Other formats of super-frames or frames can also be used. Each super-frame includes a usable portion 720 and an unusable portion. During the usable portion (or active time), data is transmitted. During the unusable portion, no data should be transmitted. In one embodiment, the usable portion lasts for 1.2852 milliseconds. The unusable portion includes a late arrival window 724, a payload transition time 722 and an early arrival window 726. Late arrival window 724 lasts for 0.0665 μ s and accounts for communication that is arriving at the satellite slightly later than ought to be. Early arrival window 726 allows for 0.0665 μ s and accounts for any data for the next epoch that arrives slightly early. Payload transition time 722 lasts for 1.001 μ sec. During payload transition time 722, the satellite is unavailable to communicate along its various communication paths because the various selection matrices and/or the digital channelizer are adjusting/reconfiguring for the next epoch. As can be seen the entire epoch lasts for 1.286334 milliseconds. The technology described herein is not limited to any specific timing; therefore, other timing for the super-frame and transmission can also be used.

An alternative embodiment includes adding beam hop transition time between super-frames. This could also be in terms of integer number of symbols to help clocks stay synchronized, if needed. This in effect adds padding time between defined super-frames in order to configure transition time.

FIG. 26 also shows the same-super-frame of FIG. 25, but indicating the data contents. The unusable portion of the super-frame, which includes late arrival window 724, payload transition time 722 and early arrival window 726, utilizes the time for transmitting 540 symbols. However, no real data symbols will intentionally be transmitted during these times by the satellite. The usable portion 720 of the super-frame includes a header and a payload. The header, which uses 720 symbols, includes two fields: SOSF and SFFI. In one embodiment, SOSF is a start of a super-frame preamble that is a unique combination of bits to indicate a super-frame is starting. In one embodiment, SFFI is a super-frame format indicator which indicates which of the different super-frame formats this particular super-frame is implementing. In one embodiment, more than one super-frame format can be used for different types of communication. In some embodiments, only one format will be used for the communication system. In one embodiment the payload is broken up into a set of capacity units (CU). In one embodiment, each CU is 90 symbols and represents a slot in the payload. In one example implementation, the capacity units can be divided up between subscriber terminals within a spot beam so that different subscriber terminals will receive communication in different capacity units. This allows a type of time domain multiplexing of the data path. As depicted in FIG. 27, one embodiment of the Payload includes CU9-CU6800.

FIG. 28 describes some of the timing involved in the satellite communication system described herein. For example, FIG. 28 indicates that the propagation delay between the gateway and the satellite (SB propagation delay) is approximately 54-72 msec. The processing delay of communication through the satellite is approximately 20-30 μ sec. The propagation delay from the satellite to the subscriber terminal for the non-articulated spot beams performing time domain beam hopping (HB propagation delay) is approximately 54 to 72 msec. Therefore, the satellite will

transmit to a subscriber terminal in a hopping beam data that was sent by the gateway between 74 and 102 milliseconds previous. That is, the satellite is configured to receive data for a particular epoch that was sent previous to a start of the particular epoch by a time period that is significantly greater than the length of the epoch itself. For example, the data for the particular epoch can be sent to the satellite previous to the start of the particular epoch for transmitting the data by a time period that is greater than 10 or 30 times the length of the epoch. This requires very precise timing by the gateway.

There is a delay through the satellite payload so that the portion of the super-frame (see FIGS. 25 & 26) corresponding to payload transition time 722 enters the payload 20-30 μ sec before it leaves the payload. Thus, the portion of the super-frame corresponding to payload transition time 722 is experienced/implemented by different portions of the payload at different times. FIG. 6 shows one example of a payload that comprises various selection matrices and a digital channelizer. Other switching components can also be used on the satellite. Different selection matrices and the digital channelizer may experience/implement payload transition time 722 at different moments in time. In one embodiment, the components of the payload have to time their reconfigurations so that the payload transition time 722 arrives at the component when it needs to reconfigure. Thus, the payload transition time 722 is implemented by different groups of switching components at different times such that different groups of switching components reconfigure for a new hopping plan at different times.

FIG. 29 is a flowchart describing one embodiment of a process for performing time domain beam hopping, as discussed above. In step 800, the system operates the constellation of non-geostationary satellites along the same orbital path using the same beam map. The beam map of each satellite is adjacent to a beam map on the adjacent satellite to provide a composite beam map that circumnavigates the Earth. Each satellite provides a plurality of spot beams as the satellites moves across the planet surface. In step 802, all or a subset of satellites receive in-orbit instructions that include one or more hopping plans or hopping patterns, as well as one or more user beam to gateway beam connectivity plans. All gateways receive satellite dependent, time frequency dependent allocations of one or more gateway beam's bandwidth aligned with provisioned satellite user beam and gateway beam hopping patterns. In step 804, based on the received instructions in step 802, one or more satellites reconfigure their user beam to gateway beam connectivity (e.g., selection matrices and/or digital channelizer) and/or update their hopping plan based on the received new hopping pattern (e.g., programming a non-geostationary satellite to assign any combination of epochs in a hopping plan among spot beams of a same hopping group). In step 806, each satellite simultaneously performs time domain beam hopping for the plurality of non-articulated spot beams based on the hopping group so that a subset of spot beams in each hopping group are active at any given time. In one embodiment, each of steps 800-806 are performed continuously, and the process of FIG. 29 is performed repeatedly. In one embodiment, each gateway performs TDMA connectivity and sub-allocation according to its satellite-dependent, time-dependent, and user-beam-dependent gateway beam allocations. This gateway TDMA connectivity is implemented in independent time synchronization with each of the one or more satellites to which it is provisioned gateway beam allocations.

In one embodiment, the non-geostationary satellites described above includes a forward path and a return path, such that the forward path has different hopping plans than the return path. That is, the beam hopping for the forward path can be different than the beam hopping for the return. For example, the forward path can have different hopping groups, sequences and/or dwell times than the return.

Multiplexing Gateways

Looking back on FIG. 24, all the beams of a hopping group are switched so that at any one given epoch one of the beams of the hopping group are in communication with a feeder beam. In another embodiment, the hopping group can be in communication with multiple feeder beams that are time multiplex. For example, FIG. 30 shows non-articulated spot beams implementing time domain beam hopping, including spot beams 2, 24, 56, 79, 130, 154 and 190. At any given epoch, only one of those time domain beam hopping spot beams will be active. FIG. 30 shows two feeder beams FB1 and FB2. FB1 connects to one gateway. FB2 connects to a second gateway. Thus, FIG. 30 shows a first plurality of spot beams (2, 24, 56, 79, 130, 154 and 190) and a second plurality of spot beams (FB1 and FB2). At any epoch, one spot beam of the hopping beams is active and one spot beam of the feeder beams is active in order for the two active beams to communicate. Thus, each of satellites 302-322 are configured to provide a first plurality of spot beams (e.g., spot beams 24, 56, 79, 130, 154, 190) for communication with subscriber terminals using time domain beam hopping to move throughput between spot beams of the first plurality of spot beams and a second plurality of spot beams (e.g., FB1 and FB2) adapted for communication with gateways. The satellites each include a spectrum routing network (one or more of the selection matrices and/or channelizer) that is configured to time multiplex the spot beams of the second plurality of spot beams with spot beams of the first plurality of spot beams. That is, each active time hopping beam can communicate with either one of the feeder beams at different epochs. For example, spot beam 130 communicates with FB2 at epoch E4 and FB1 at epochs E5 and E6, all while spot beam 130 remains over a subscriber terminal location on the planet surface. Similarly, spot beam 2 communicates with FB1 and epochs E0, E1, E2 and E3 and communicates with FB2 at epochs E7 and E8, all while spot beam 2 remains over a subscriber terminal location on the planet surface. In one embodiment, a spot beam's communication with a first gateway can be interleaved with its communication with a second gateway so that the respective sets of epochs are interleaved (set of epochs 18, 19 and 23 intermixed with set of epochs 20, 21, 22 and 24). When more than one gateway is supported in a feeder beam the N gateways may operate on different frequencies or the same frequency. If operating on one frequency each gateway will have a different epoch assigned for transmission and reception.

FIG. 31 is a flowchart describing one embodiment of a process for performing time domain beam hopping with time multiplexing gateways, as depicted in FIG. 30. The process of FIG. 31 is continuously performed by each of satellites 302-322. In step 840, each satellite provides a first plurality of spot beams in order to communicate with subscriber terminals, as the satellites move across the planet surface. In step 842, the satellites will perform time domain beam hopping for the first plurality of spot beams. In step 844, each of the satellites provides a second plurality of spot beams in order to communicate with the gateways, as the satellites move across the planet surface. In step 846, each satellite provides time multiplexing of the spot beams of the

second plurality of the spot beams with the spot beams of the first plurality of spot beams while a particular spot beam of the first set of spot beams remains over a particular location (e.g., route communications between different beams of the second plurality of spot beams and a particular beam of the first plurality of spot beams at different epochs of multiple epochs during the hopping period).

FIG. 31 shows one example implementation of step 846 includes steps 846A and 846B. In step 846A, a satellite provides communication between a particular spot beam of the first plurality of spot beams and a first spot beam of the second plurality of spot beams during a first set of epochs while the particular spot beam is over a location on the planet surface (e.g., while illuminating a set of one or more subscriber terminals). In step 846B, the satellite provides communication between the particular spot beam and a second spot beam of the second plurality of spot beams during a second set of one or more epochs while the particular spot beam remains over the location on the planet surface. So during a particular hopping period, a hopping beam can communicate with different feeder beams.

FIG. 32 provides a flowchart describing one embodiment of a process for performing time domain beam hopping on a satellite that includes the multiplexing of gateways as described above. In step 860, the satellite transmits data for the current epoch for the current set of service beams and feeder beams, as routed by the channelizer and the various selection matrices. In step 862, the satellite transmits data that arrived late for the current epoch for the current set of service beams and feeder beams as routed by the channelizer and selection matrices. In one embodiment, step 860 corresponds to transmitting the payload of a super-frame and step 862 corresponds to transmitting the late arrival window 724 of a super-frame (see FIG. 26). In step 864 of FIG. 32, satellite reconfigures routing of all or some (or none) of the routing paths of the channelizer and selection matrices to set up communication for service beams with different one or more feeder beams, and reconfigures the selection matrices for the next hopping arrival. In one embodiment, step 864 corresponds to reconfiguration time 722. In step 866, the satellite transmits data that arrives early for the next epoch for the new set of service beams and feeder beams as routed by the channelizer and selection matrices. In one embodiment, step 866 corresponds to early arrival window 726. Step 860-866 correspond to one epoch. If this epoch was not at the end of a hopping period (step 868), then the process will continue back at step 860 to perform transmission of data for the next epoch. However, if this epoch was the last epoch of the hopping period (step 868), then the satellite can load a new hopping plan and new gateway multiplexing plan. In one embodiment, step 870 is optional. After step 870, the process loops back to step 860 and performs the next epoch for the next hopping period.

Allocating Throughput

As discussed above, the hopping plan assigns different epochs to different beams of the hopping group. Thus, the system can allocate different amounts of throughput to each beam of the hopping group, where the amount of throughput allocated corresponds to the number of epochs assigned to the particular beam of the hopping group. In one embodiment, the amount of throughput (the amount of epochs) assigned to each hopping beam is based on demand of users within the coverage area during a given hopping period. In some embodiments, as discussed above, the non-articulated spot beams can be used to service both subscriber terminals and gateways. In that situation, the allocation of throughput to a spot beam can be based on the throughput needs of the

gateway in the spot beam as well as the subscriber terminals in the spot beams. Thus, the number of epochs assigned to that spot beam is based on the needs of the gateway and the needs of all the subscriber terminals. Note that the epochs assigned to a beam for a hopping plan can be continuous or non-continuous (spaced apart in time).

FIG. 34 depicts an embodiment where a satellite is configured to provide a plurality of spot beams adapted for communication using time domain beam hopping to switch throughput among spot beams of a hopping group, where the plurality of spot beams includes at least one spot beam that illuminates and communicates with a gateway and a plurality of subscriber terminals. A satellite is configured to implement a beam hopping plan that during a hopping period provides throughput to the first spot beam for an aggregated time duration (e.g., number of epochs) based on the bandwidth assignments to the gateway and the plurality of subscriber terminals. Note that the performing time domain beamed hopping for the spot beam includes providing throughput to the spot beam for a non-continuous set of multiple epochs that form the aggregated time duration. For example, FIG. 33 shows satellite 201 providing spot beams 950, 952 and 954 in hopping group A and spot beams 956, 958, and 960 in hopping group B. Satellite 201 also provides steerable feeder beam 962. Non-articulated spot beam 950, at this point in time, illuminates and communicates with subscriber terminals ST and a gateway GW. Spot beam 952 also communicates with subscriber terminals ST and a gateway GW. Spot beam 954 communicates only with subscriber terminals ST. Spot beams 956, 958 and 960 only communicate with subscriber terminals ST. Because spot beams 950, 952 and 954 are in a same hopping group, satellite 201 performs time domain beam hopping such that only one of those three spot beams are active at a given time. That means that only one of gateway 950 and 952 can be active at the same time. Thus, the performing time domain beam hopping for the plurality of spot beams includes providing throughput to multiple gateways over time that are geographically separated from each other because they are in separate spot beams. In the embodiment depicted in FIG. 33, the amount of throughput provided to spot beam 950 (e.g., number of epochs assigned) is based on the throughput needs of the subscriber terminals as well as the throughput needs of the gateway in spot beam 950. The amount of throughput provided to spot beam 952 (e.g., the number of epochs assigned in the hopping plan) includes enough throughput (e.g., epochs) to service the subscriber terminals ST in spot beam 952 as well as servicing the gateway GW in spot beam 952. Note that spot beam 954 does not include a gateway. In one embodiment, each of the subscriber terminals in spot beam 954 can communicate with either the gateway in spot beam 950 or the gateway in spot beam 952 by multiplexing between the two gateways, as described above.

FIG. 34 is a flowchart describing one embodiment of a process for operating a satellite that includes performing time domain beam hopping for the plurality of spot beams including implementing a beam hopping plan that during a hopping period provides throughput to first spot beam for an aggregated time duration based on bandwidth assignments of the gateway and subscriber terminals in that spot beam. In step 902, the system will determine demand over time for the subscriber terminals. This can be performed at the network control center. In step 904, based on the beam map, gateways are assigned to various hopping groups. In step 906, the system determines the bandwidth needs of the service links (communication with subscriber terminals)

based on the demand over time of the subscriber terminals. In step **908**, the bandwidth needs of the feeder links (communication with gateways) in the hopping beams will be determined based on demand of the subscriber terminals in communication with the gateways. In step **910**, bandwidth will be determined for the feeder links in dedicated feeder beams (e.g., the steerable beams as opposed to the non-articulated beams that are shared between subscriber terminals and gateways). In step **912**, a hopping beam plan will be created for the multiple/different hopping periods. In step **914**, the created hopping plans are transmitted to all the satellites while the satellites are in orbit. For example, the network control center will transmit the hopping plans to the satellite when the satellites pass over or by the network control center. These hopping plans are received by the satellites and stored in the memory for the satellites. In step **916**, each satellite will update or otherwise change its current hopping plan so that a new hopping plan is implemented at the appropriate time or times. The satellites each perform time domain beam hopping of the plurality of non-articulated spot beams including implementing a then-current beam hopping plan that during a hopping period provides throughput to one or more spot beams for an aggregated time duration based on the bandwidth assignments of gateways and subscriber terminals.

FIG. **35** is a chart describing one example of sharing capacity by dividing up epochs or CUs in the epoch based on pro rata throughput needs. For example, FIG. **35** shows the dividing up of CUs or epochs for hopping group A, hopping group B and beam **962** of FIG. **33**. As beam **962** only includes a single gateway, all time is available to that gateway. In some embodiments, there can be multiple gateways in spot beam **962** so that the throughput of spot beam **962** must be divided among the multiple gateways. Hopping group B includes three beams that only includes subscriber terminals. The amount of throughput (or epochs) provided to beam **956** is represented in FIG. **35** as **956S**. The amount of throughput provided to beam **958** is represented as **958S**. The amount of throughput provided to spot beam **960** is represented as **960S** in FIG. **35**. As can be seen, the amount of throughput or number of epochs is not divided equally among the three spot beams. In FIG. **35**, the amount of throughput or epochs provided to spot beam **954** (that does not include a gateway) is represented by box **954S**. The amount of throughput or epochs provided to spot beam **950** is represented by two components: one component **950S** accounting for the throughput assignment to subscriber terminals and a second component **950G** representing the assignment of throughput to the gateway in spot beam **950**. Since, in beam **950**, the gateway may use different frequency than the users the first and second component can exist simultaneously. The amount of throughput or epochs provided to spot beam **952** includes two components: **952S** represents the amount of throughput assignment accounted for the subscriber terminals and **952G** represents the assignment of bandwidth for gateway. Since, in beam **952**, the gateway may use different frequency than the users the first and second component can exist simultaneously.

As mentioned above, in some embodiments there can be multiple gateways in a gateway beam. These multiple gateways can support (ie communicate with) different subscriber terminal sets in the same one or more spot beams that perform time domain beam hopping or support (ie communicate with) different subscriber terminal sets in the different one or more spot beams that perform time domain beam hopping. In another alternative, these multiple gateways can support (ie communicate with) the same subscriber termi-

nals. The multiple gateways in the same spot beam will use different epochs to communicate with the subscriber terminals.

In some embodiments, a satellite has two or multiple spot beams in a hopping group that illuminate and communicate with gateways and subscriber terminals, where the gateways are geographically separated from each other. For the multiple spot beams that illuminate and communicate with gateways and subscriber terminals, they are all individually assigned frequency throughput for a total time duration based on throughput assignments of the respective gateways and subscriber terminals. Therefore, the satellite performs time domain beam hopping, including providing throughput to multiple gateways over time that are geographically separated from each other.

In regard to the constellation of satellites **302-322**, the providing a plurality of spot beams and performing time domain beam hopping for the plurality of spot beams are performed separately and concurrently by multiple satellites using a same beam map and traveling along a same orbital path.

In one embodiment, the satellite is configured to switch throughput at a number of epochs based on the uplink and downlink demand from user terminals in the hopping group beam members. In another embodiment, the satellite is configured to switch throughput at a number of epochs based on the uplink and downlink demand from user terminals and gateways in the hopping group beam members.

Beam to Beam Handover

As each of satellites **302-322** move in orbit, their Fields of Regard move, causing each of the spot beams' coverage areas to move. As a subscriber terminal reaches the edge of a spot beam it must be handed over to the next spot beam on the same satellite. Typically, the handover will be from a spot beam in a first hopping group to a spot beam in a different hopping group. This may cause the updating of hopping plans to account for the subscriber terminal(s) changing hopping groups. When the subscriber terminal reaches the edge of a spot beam at the edge of the Field of Regard, then the subscriber terminal is handed over to the next satellite.

FIG. **36** graphically depicts a portion of the satellite communication system, showing a handover of subscriber terminal between spot beams of the same satellite. For example, FIG. **36** shows satellite **201** traveling in the orbital direction **201A** providing spot beam **980** and spot beam **982**. As satellite **201** moves in direction **201A**, subscriber terminal ST will move from spot beam **980** to spot beam **982**; therefore, a handoff must occur. FIG. **36** shows spot beam **201** in communication with gateway **984** (which includes antenna **986**). In one embodiment, gateway **984** includes modem **990** connected to antenna **986**, network interface **994** connected to network **988** (which may be the Internet or other network), and gateway processor **992** which is connected to modem **990** and network interface **994**. In one embodiment, gateway processor **992** can be a computing device that includes one or more microprocessors, memory, nonvolatile storage, etc.

Because subscriber terminal ST is being handed over from spot beam **980** to spot beam **982**, gateway processor **992**, which receives messages from network **988** to be sent to subscriber terminal ST, must communicate those messages via the appropriate spot beam. For example, FIG. **36** shows gateway **984** communicating messages A, B, C and D. Because the timing of the transmission of the messages (in light of the hopping plan), message A and message B will be transmitted from the satellite **201** to subscriber terminal ST

while subscriber ST is in spot beam **980**. Messages C and message D will be transmitted from satellite **901** to subscriber terminal ST while subscriber terminal ST is in spot beam **982**. Note that spot beam **980** and **982** are among the non-articulated spot beams that implement time domain beam hopping. Furthermore, spot beam **980** has a different frequency range than spot beam **982**, but both spot beams use the same polarization. In other hopping arrangements, spot beams **980** and **982** can have the same frequency range or overlapping frequency ranges.

FIG. **37** is a flow chart describing one embodiment of a process performed by the gateway for performing handover of subscriber terminal between spot beams on the same satellite. In step **1002**, gateway processor **992** determines new handover times for all terminals connected to that particular gateway based on the satellite's location, the known beam pattern and the known beam hopping plan(s) as well as the position of the terminals (or feedback of the signal strength received by the subscriber terminals from the satellite). In step **1004**, gateway processor **992** determines (calculates or looks up in a database) new hopping plan(s) for the spot beams based on updated terminals and the beams. For example, when subscriber terminal ST transitions from beam **980** to beam **982** that may affect the hopping plan due to a change in demand. In step **1006**, gateway **984** will broadcast the handover information to all the terminals in all the spot beams communicating with the gateway **984**. The handover information includes a set of records, with each record including a terminal ID for the subscriber terminal, old spot beam, new spot beam, and time of handover. Other information could also be provided. In step **1008**, the gateway broadcast the new hopping plan to the terminals and the satellite. In one embodiment, the satellite already has the hopping plan and does not have it communicated from the gateway.

FIG. **38** is a flow chart describing one embodiment of a process performed by the gateway for performing a handover of the subscriber terminal, at the time of hand off. In step **1040**, gateway processor **992** receives data from network **988**, which is to be transmitted to subscriber terminal ST. In step **1042**, gateway processor **992** determines the time for transmission of that received data from the satellite **201** to subscriber terminal ST. In step **1044**, gateway processor **992** checks the latest handover information (see step **1006** in FIG. **37**). In step **1046**, gateway processor **992** determines whether the time that the satellite will be transmitting the data to the subscriber terminal is near handover time. If that time is not near the handover time, then in step **1048** gateway processor **992** communicates the received data using the current hopping plan and the current hopping group as well as normal margins for Adaptive Coding and Modulation (ACM) and Time Domain Beam Hopping (TDM). In one embodiment, the margins for TDM relate to the size or timing of the late arrival window and early arrival window. If the time for transmission from the satellite is near the handover time but before the handover time, then step **1050** gateway processor **992** communicates the data to the terminal using the pre-handover hopping beam, of the pre-handover hopping group and wider margins (if needed) for ACM and TDM. If the time for transmission from the satellite to the terminal is to be after the handover time, then gateway processor **992** communicates the data using the post-handover hopping beam of the post-handover hopping group and wider margins (if needed) for ACM and TDM.

FIG. **39** is a flow chart describing one embodiment of a processor performed by a subscriber terminal in regarding to handing over the subscriber terminal between spot beams.

The process FIG. **39** is performed in response to the gateway performing the processor FIG. **37**. In step **1060** FIG. **39**, the terminal receives broadcasted handover information (see step **1006** of FIG. **37**). In step **1062**, if the received broadcast includes handover information for that terminal, then that terminal stores the information and will configure it during an epoch when the beam is not active or during the payload transition time. Note that the processes of FIGS. **37** and **39** are performed continuously.

FIG. **40** is a flow chart describing one embodiment performed by a subscriber terminal at the time for a handover between spot beams. It was noted that in step **1062**, an interrupt is configured. That interrupt will trigger the performance of the process of FIG. **40**. In step **1070**, it is determined whether the terminal is at or near a time of a handover. If not, and the terminal receives data in step **1072** (in response to step **1048** of FIG. **38**), then the terminal decodes that data in step **1074** using normal margins for ACM and TDM. The data is reported to a client in step **1076**. A client for a subscriber terminal can be a computing device, smart appliance, etc. If, in step **1070**, is determined that the terminal is near a handover time, but before the handover time, then in step **1080**, the terminal will receive data from the satellite and decode that data in step **1082** using the wider margins for ACM and TDM. The data will then be reported in step **1076**. If the terminal is at a time for handover then in step **1086** the terminal retunes its local oscillator to change frequencies to the master frequency for the new spot beam. That is, looking back at FIG. **36**, subscriber terminal ST will retune its local oscillator from the frequency for spot beam **980** to the frequency for spot beam **982**. In step **1088**, the hopping plan will be updated. In some embodiments, the terminal keeps tracking of the hopping plan. In other embodiments, the terminal will not keep track of the hopping plan. In one embodiment, a subscriber terminal will include one antenna and one oscillator. In other embodiments, the subscriber terminal includes two antennas and two oscillators to alternate using terminals and oscillators between spot beams.

FIG. **41** depicts a portion of a satellite communication system showing a handover of a subscriber terminal between spot beams of different satellites. For example, FIG. **41** shows satellite **1100** and satellite **1102**, which can be any pair adjacent satellites of satellite **302-322**. Satellite **1102** provides spot beam **1106**. Satellite **1100** provides spot beam **1104**. The subscriber terminal **1108** includes two antennas **1110** and **1112**, two modems **1114** in communication with antenna **1110** and modem **1116** in communication with antenna **1112**, terminal processor **1116** and network interface **1118** which is connected to a local area network (LAN). Terminal processor **1116** can be any computing device suitable that includes a processor, memory, nonvolatile memory and appropriate communication interfaces.

In FIG. **41**, subscriber terminal **1108** is positioned in a region that represents where spot beam **1106** overlaps with spot beam **1104**. Gateway **1120** is communication with both satellites **1100** and **1102**. Gateway **1120** includes a first antenna **1124** for communicating with satellite **1100**. Gateway **1120** includes antenna **1122** for communicating with satellite **1102**. Gateway **1120** includes a first modem **1128** connected to antenna **1124** to second modem **1126** connected to antenna **1122**. Gateway **1128** includes gateway processor **1130** connected to both modem **1126** and **1128**. Gateway processor **1130** is also connected to network interface **1132**, which can communicate with the Internet or other network. Because gateway **1120** is in communication with both satellites, and utilizes one processor **1130**, when the

subscriber terminal hands over from satellite **1102** to satellite **1100** the communication between subscriber terminal **1108** and gateway **1128** will not be broken. So as satellites **1102** and **1100** move west to east, causing subscriber terminal **1108** to transition from spot beam **1106** on satellite **1102** to spot beam **1104** on satellite **1100**, the communication path between subscriber terminal **1108** and gateway **1128** will change from going via satellite **1102** to going via satellite **1100**. Gateway **1120** will perform the process of FIG. **37** described above for identifying and communicating the handover information.

Additionally, gateway will perform the process depicted in FIG. **42** for handing over a subscriber terminal between spot beams of different satellites. In step **1200**, gateway processor **1130** communicates with the current satellite via first antenna (e.g., antenna **1122**). In step **1202**, gateway **1120** establishes communication with the new satellite via a second antenna **1124**. In step **1204**, the gateway determines when the switch terminals to the new satellite based on the handover information described above. Gateway **1120** will inform the satellites and the subscriber terminals as per the process of FIG. **37**. In another embodiment, the satellites are preprogrammed as to when to switch. In another embodiment, the gateway informs the network control center. In step **1206**, the gateway communicates with the terminal via the current satellite (e.g., satellite **1102**) until the handover time, performing the process of FIG. **38** using the first antenna (antenna **1122**) and the current beam hopping plan. In step **1208**, the gateway communicates with the terminal via the new satellite (satellite **1100**) after the handover time using the new hopping plan, performing the process of FIG. **30** using the second antenna (e.g., antenna **1124**). The subscriber terminal will perform the process of FIG. **39**, as described above, to receive the new handover information. Additionally, the subscriber terminals will perform the process of FIG. **43** at the time of handover. In step **1250**, the gateway decides whether the subscriber terminal is at or near the satellite handover time. If the subscriber terminal is not at or near a satellite handover time, then step **1252**, data will be communicated with the satellite via its first antenna (e.g., antenna **1110**). In step **1254**, the gateway will decode received data using normal margins for ACM and TDM. In step **1256**, received data will be reported to the client. Note that data that is transmitted will not need to be decoded and reported, but rather would be encoded.

If, in step **1250**, it is determined that the subscriber terminal is near handover time, then at step **1260**, the terminal will establish or maintain a connection with the gateway via the second antenna and second satellite. In step **1262**, the subscriber terminal will continue communicating data with the satellite via the first antenna. In step **1264**, received data will be decoded by the gateway using wider margins for ACM and TDM. In step **1266**, data received will be reported. Data that is being transmitted will be encoded using wider margins for ACM and TDM, if ACM is being used on the up link for the return path.

If in step **1250**, it is determined that the subscriber terminal is at the handover time, then step **1270**, the subscriber terminal switch to communicating data with the second or new satellite via the second antenna. In step **1272**, a new hopping plan will be implemented. In one embodiment, the subscriber terminal does not know what the hopping plan is and just reacts to data from the gateway and, therefore, will not be aware of the new hopping plan. In step **1274**, data received will be decoded using wider margin for

ACM and TDM. Data transmitted will use wider margins for ACM, if ACM is being used. Data received will be reported in step **1276**.

The above description of beam to beam handovers includes communicating, at a ground base terminal, with a non-geostationary satellite constellation using a first spot beam of the non-geostationary satellite constellation and the first beam hopping plan; and the ground based terminal changing the communicating with the non-geostationary satellite constellation to use a second spot beam of the non-geostationary satellite constellation in a second hopping beam.

Handover for Multiple Gateways

As described above, some of the non-articulated spot beams **1-200** for each of the satellites **302-322** can be used to service subscriber terminals and gateways. In some embodiments, subscriber terminals in the non-articulated spot beams are configured to communicate with gateways in the non-articulated spot beams. In such embodiments, the group of subscriber terminals communicating with the gateway and the non-articulated beams will need to communicate with at least two gateways. In one implementation, the two gateways communicating with the group of subscriber terminals are in the same country as the subscriber terminals in order to comply with local laws restricting communicating across borders. In other embodiments, the two gateways can be in different countries.

FIG. **44** shows an example configuration where two gateways **986** and **988** communicate and service subscriber terminal ST via Satellite **1**. Each of the gateways has its own antenna and its own modem. For example, gateway **986** includes modem **991** and gateway **988** includes modem **993**. Neither gateway includes a gateway processor. Rather, both modems **991** and **993** communicate with a central processor **992** which is in communication with the network interface **984** for communicating on network **988** (e.g., Internet). By sharing a central processor **992**, streams of communication between the subscriber terminal ST and entities on network **988** may be maintained in a manner with no apparent interruption. In one embodiment, gateway **986** is located at the western edge of the subscriber terminals and gateway **988** is located at the eastern edge of the subscriber terminals. Therefore, these gateways can be referred to as the eastern gateway and the western gateway. The reason for locating the gateways on the western edge and the eastern edge is because the satellites **302-322** move from west to east and locating the gateways at the western edge and the eastern edge (separated in the orbital direction) allows for efficient handovers. In other embodiments where the satellites travel at a different orbital direction, the gateways will be located at different locations that are separated from each other by different orbital directions. That is, the first gateway will be a first location, the second gateway is at a second location, and the second location is separated from the first location in the orbital direction.

FIG. **45** is a flow chart describing one embodiment of a process for performing the handover between satellites, with the use of eastern and western gateways, where the gateways are operating within and communicating with spot beams implementing time domain beam hopping. Note that rather than using eastern and western gateways, the same process can be used for two different gateways at two different locations separated in the orbital direction. In step **1350**, all or a subset of subscriber terminals communicate with the eastern gateway via satellite **1** as the non-articulated spot beam implementing time domain beam hopping traverse the region where the subscriber terminals are located. FIG. **46A**

shows the time when step **1350** is performed. Field of Regard for satellite **1** is completely covering spot beams A, B, C, D, J, F, and G, which are the spot beams for which the subscriber terminals are located. At the eastern edge of spot beam C is eastern gateway E. The western edge of spot beam J is western gateway W.

In step **1354**, western gateway W hands over to satellite **2**, as soon as possible (or as close to as soon as possible). For example, FIG. **46B** shows that the Field of Regard for Satellite **2** is very close to spot beam J, close enough to allow western gateway W to connect to Satellite **2**.

In step **1356**, as the Field of Regard for Satellite **2** passes over the spot beams, subscriber terminals in the spot beams under the Field of Regard for Satellite **2** begin to connect to Satellite **2**. As discussed above, the subscriber terminals will be told ahead of time of the handover information. Thus, when subscriber terminals handover to Satellite **2**, they will begin to connect to and communicate with the western gateway via Satellite **2**. For example, FIG. **46J** shows a portion of the Field of Regard for Satellite **2** over spot beams A, J and G, and the Field of Regard for Satellite **1** over spot beams A, G, D, B, C and F. Subscriber terminals in spot beams A, J and G will have connected to Satellite **2** and began communicating with gateway W via Satellite **2**.

After all the terminals in spot beams A, B, C, D, J, F, and G have handed over to Satellite **2** and are in communicating with western gateway, the eastern gateway E will handover to Satellite **2**. For example, FIG. **46D** shows all five spot beams within the Field of Regard for Satellite **2**; therefore, all the subscriber terminals have been handed over and connected to Satellite **2** and are in communication with the western gateway via Satellite **2**. In step **1360**, in response of instructions from the central processor **992**, all of the subscriber terminals will then switch to communicating with the eastern gateway E via Satellite **2**. The process of FIG. **45** will then be performed again with Satellite **3** (not depicted), then with satellite **4** (not depicted), etc. In this manner, the plurality of subscriber terminals are configurable to communicate with central processor **992** via the non-geostationary satellites via the first eastern gateway or the western gateway. The central processor **992** is configured to assign each subscriber terminal to communicate with the central processor **992** via the eastern gateway or the western gateway based on location of the appropriate non-geostationary satellite.

In some embodiments, the eastern gateway (and some subscriber terminals) and the western gateway (and some subscriber terminals) are in different non-articulated spot beams that implement time domain beam hopping and that are in the same or different hopping groups performing the same or different hopping plans.

Steerable Gateway Beams

As discussed above with respect to FIG. **2**, each of the satellites **302-322** include eight steerable 4.2 degree gateway beams and six steerable 2.8 degree gateway/high capacity subscriber terminal beams. Additionally, each of the non-geostationary satellites of the constellations configured to provide a first plurality of two hundred non-articulated spot beams that comprise the Field of Regard. The steerable spot beams can be steered to establish communication with a gateway outside of and in front of the Field of Regard and maintain that communication while the satellite and the Field of Regard move over and the past the gateway including when the gateways outside of and behind the Field of Regard for the respective satellite. This enables the gateways to establish connection with the satellite prior to the spot beams covering the subscriber terminals and then maintain

connection to the satellite while the subscriber terminals handover to the satellite and while the subscriber terminals handover to the next satellite to allow seamless communication for the subscriber terminals. This configuration is depicted graphically in FIG. **47** which shows satellite **1400** and satellite **1402**. Satellite **1400** provides non-articulated spot beam **404** which implements time domain beam hopping for communicating with the plurality of the subscriber terminals ST. Satellite **1402** provides non-articulated spot beam **1406** that implements time domain beam hopping for communication with a plurality of subscriber terminals ST. It is possible that both satellites **1400** and **1402** are simultaneously in communication with gateway **1120**. In another embodiment, epoch allocations are made to non-articulated beams such that no beam hopping is required in a geographic area.

In one embodiment, gateway **1120** includes two antennas, including antenna **1122** for communicating with satellite **1402** (the eastern satellite) and antenna **1124** for communicating with satellite **1400** (the western satellite). As the satellites of the constellation move west to east, the gateway's antennas will be in communication with different pairs of satellites. Gateway **1120** includes the modem **1126** in communication with antenna **1122** and modem **1128** in communication with antenna **1124**. Gateway **1120** also includes gateway processor **1130** that is in communication with modem **1126**, modem **1128** and network interface **1132** (which connects to the Internet or other network). The spot beams that satellite **1402** and **1400** use to connect to gateway **1120** are steerable so that they can remain pointed at the gateway as the satellites and the Field of Regards move. This is described in more detail with respect to the flow chart of FIG. **48** and the graphs of FIGS. **49A-E**.

In step **1430** of FIG. **48**, the gateway is connected to satellite **1** via steerable spot beam for satellite **1** in order to communicate with its subscriber terminals via satellite **1**. In step **1432**, while the gateway is communicating with subscriber terminals via satellite **1** (e.g., the gateway is in the Field of Regard satellite **1**) and the gateway is not in the Field of Regard of satellite **2** because the gateway is east (in front) of satellite **2**, the gateway establishes synchronization with satellite **2** using the timing beacon for satellite **2** (timing synchronization aligns gateway forward burst with the allocated time slot reference on the satellite). In step **1434**, satellite **2** moves its steerable beams (e.g., beams **286**, **288**, **290**, **292**, **294**, **296**, **270**, **272**, **274**, **276**, **278**, **280**, **282** or **284** of FIG. **2**) to point at the gateway and the gateway initiates a forward link for communication with the subscriber terminals. FIG. **49A** depicts the situation existing at the time of step **1434**.

FIG. **49A** shows the gateway GW surrounded by five coverage areas B1, B2, B3, B4 and B5 each of those coverage areas B1-B5 include a plurality of subscriber terminals that are supported by and are in communication with the gateway. FIG. **49A** shows that the Field of Regard for satellite **2** is east of the gateway and the coverage areas B1-B5 such that is not covering or overlapping with the gateway or the coverage area of B1-B5. Despite the fact that the gateway is outside the Field of Regard for satellite **2**, satellite **2** points/moves one of its steerable beams to cover (point at) and communicate with the gateway.

In step **1436**, satellite **2** establishes internal connectivity to service the gateway, including providing initial bandwidth to the steerable spot beam for establishing communication. Satellite **2** provides connectivity for the gateway to communicate via the steerable spot beam with subscriber terminals. In step **1438**, as the non-articulated spot beams per-

forming time domain beam hopping (and the Field of Regard) traverse across the coverage region supported by the gateway, additional terminals handover to satellite 2 and re-establish communication with the gateway. For example, FIG. 49B shows a portion of the Field of Regard for satellite 2 covering and including coverage areas B1 and B5. Therefore, subscriber terminals in coverage areas B1 and B5 will have handed over to satellite 2 and established communication with gateway GW via satellite 2.

As discussed above, the steerable beams can include a single purpose beam that only communicate with gateways or dual purpose beams that can communicate with gateways and subscriber terminals. If the steerable spot beam that is pointed to and communicating with the gateway is a dual purpose spot beam, then as that dual purpose spot beam traverses across the Field of Regard, including the non-articulated spot beams implementing time domain beam hopping, the system can optionally use the steerable spot beam for communicating with the subscriber terminals. If the system uses the steerable spot beam to communicate with the subscriber terminals, then the non-articulated spot beams that implement time domain beam hopping that overlap with the steerable spot beam will (optionally) be turned off while they overlap with the steerable spot beam. When these non-articulated spot beams are turned off the one or more epochs that they would have been assigned in the hopping plan are then provided to other spot beams in the same hopping group in step 1440. In step 1442, as more subscriber terminals establish communication with the gateway (due to movement of satellite 2), satellite 2 provisions more bandwidth to the gateway including updating internal connectivity to provide additional bandwidth. That is, the steerable spot beam can be able to communicate using multiple colors (see frequency plan described above). Initially one color can be provided to the spot beam. As more subscriber terminals connect to the gateway, additional colors can be added to the non-articulated spot beams frequency allocation. FIG. 49C shows the Field of Regard for satellite 2 encompassing the gateway in coverage regions B1-B5. Therefore, all the subscriber terminals that are supported by gateway GW are now communicating with gateway GW via satellite 2. As satellite 2 moves from its position in FIG. 49A to its position in FIG. 49C, it adjusts the pointing of the steerable spot beams so that the steerable keeps pointing at gateway GW. In step 1444, the gateway breaks its connection with satellite 1 as satellite 1 is moved to orbital position in which it can no longer service any subscriber terminals supported by the gateway, thus freeing up the steerable spot beam that satellite 1 was using to point at the gateway to be used for another gateway.

In step 1446, as the Field of Regard for satellite 2 leaves the region supported by the gateway, additional subscriber terminals start to handover to satellite 3 for communication with the gateway via satellite 3. Not that in between steps 1444 and 1446 is an arrow 1445. That arrow indicates when the process of FIG. 48 is started again for satellites 2 and 3 (rather than satellites 1 and 2). In step 1448, as most subscriber terminals stop communication with the gateway via satellite 2, satellite 2 provisions less bandwidth to the gateway, including configuring internal connectivity (the selection matrices and digital channelizer) to reduce the provisioned bandwidth for the steerable spot beam pointing at gateway GW. FIG. 49D shows the Field of Regard of satellite 2 moving east of gateway GW and only covering coverage areas B2 and B3, as well as a small portion of coverage area B4. At this point, subscriber terminals in coverage areas B1 and B5 have handed over to the next

satellite. The gateway remains in contact with satellite 2 as long as satellite 2 is in an orbital position to service any of the subscriber terminals supported by the gateway, even if the Field of Regard of satellite 2 does not illuminate the gateway because the gateway is behind the Field of Regard, as depicted in FIG. 49D (step 1450). In step 1452, the gateway will break the connection with satellite 2 if satellite 2 has moved to an orbital position which it can no longer service any terminal supported by the gateway. For example, FIG. 49E shows a Field of Regard of satellite 2 east of coverage areas B1, B2, B3, B4 and B5.

Synchronization

Because of the timing as discussed above, it is important that the satellites, subscriber terminals and gateways all remain in tight synchronization. In one embodiment, a master clock is maintained and accessed at a terrestrial location. For example, the master clock can be maintained by or at the network control center. As each satellite passes over or near the network control center, the satellites will synchronize with the network control center, or synchronize with the master clock. The gateways will then synchronize with each satellite prior to connection with the satellite so that the gateways are now in synchronization with the satellite they are communicating with. The subscriber terminals will be responsible for maintaining synchronization with the gateways. In this system, each satellite comprises an antenna system that is configured to receive command information from a ground center (e.g., network control center) includes a command to adjust a clock on the satellite to synchronize the satellite to a master clock. The satellite also sends a beacon signal toward the Earth (i.e., toward multiple gateways). The beacon signal includes timing information to synchronize the gateway to the satellite. The gateways are configured to communicate with the satellite and with the terminals via the satellite. The gateway is configured to receive the beacon signal from the satellite and synchronize to the satellite based on the beacon signal. The gateway is configured to send communication to the terminal via the satellite. The communication includes timing data for the terminal synchronize to the gateway.

FIG. 50 is a flow chart describing one embodiment of a process for performing timing synchronization for the satellite communication system. In step 1502, network control system 230 (FIG. 1) maintains a master clock. In step 1504, as the satellite passes above or near the network control center (or to the nearest location to the network control center in its orbit), the network control center sends a timing message that includes a command to set the clock on the satellite. The network control center may also send one or more hopping plans. In one embodiment, the master clock is maintained at the network control center. In another embodiment, the master clock is maintained at another location but the network control center can access the master clock and send the command to the satellite. That command can set the satellite's clock to the master clock or to adjust the satellite's clock accordingly. In step 1506, in response to receiving the command, the satellite clock sets or otherwise updates its clock to the master clock, thereby synchronizing the satellite to the master clock (and synchronizing the satellite to the network control center).

In step 1508, the satellite transmits a beacon signal that includes timing information. The beacon signal is a broad beam that may cover the entire face of the planet that can be seen by the satellite. In step 1510, prior to establishing communication with the satellite (prior to establishing communication with subscriber terminals via the satellite) for the current orbit, the gateway synchronizes with a satellite using

the satellite's beacon signal (timing synchronization aligns the gateway forward burst with the allocated time slot reference on the satellite while accounting for delay and Doppler—see step 1432 of FIG. 48). The gateway will then establish communication with the satellite to implement connections between the gateway and a plurality of subscriber terminals via the satellite. In step 1512, the gateway sends communication to the subscriber terminals via the satellite, that communication includes timing data. In step 1514, subscriber terminals synchronize to the gateway during the communication based on the timing data, aligning the subscriber terminal timing with the satellite clock. In one embodiment, the communication includes user data so that the subscriber terminal synchronizes to the gateway while communicating user data with the gateway.

FIG. 51 is a flow chart describing more details of the process for synchronizing the gateway. In one embodiment, the process of FIG. 51 is one example implementation of step 1510 of FIG. 50. In step 1532, the satellite transmits and the gateway receives the high frequency beacon signal that was broadcast to the entire visible surface of the planet. The beacon signal indicates start of an epoch and a number of epochs since midnight. In one embodiment, the entire satellite communication system has an agreed upon midnight. Note that midnight occurs at different times on the planet (i.e., difference time zones) so, in one embodiment, the system picks a single time reference to be the official midnight of the satellite system. In step 1534, using satellite ephemeris data (satellite orbit and previous time tagged locations) the gateway determines where the satellite currently is. In step 1536, based on the determined location, the gateway calculates the current time of day for the gateway (relative to epoch and epoch counts in system midnight). In step 1540, the gateway uses the timing beacon to further adjust its clock based on the calculated current time of day. In step 1542, the gateway receives one or more new hopping plans via the internet (or other network) from the network control center in order to implement in the future.

FIG. 51A provides one example of a beacon signal. In one example embodiment, the beacon signal includes a set of pulses, where the period of pulses is equal to one epoch as depicted in FIG. 51A. The beacon signal will also include a Message Block that indicates the distance in time from system midnight. The Message Block ends each set of a period of time that the gateway knows which epoch within the time of day window the epoch corresponds with. In this case, one hundred epochs (Century). Thus, the first pulse after a Message Block is the start of a new Century. Each message block will identify which century it is in. Therefore, the gateway upon receiving a message block can determine how many epochs there have been since midnight. Additionally, the gateway can use the timing of the pulses to determine when an epoch starts and therefore adjust its clock accordingly.

In one embodiment, the gateway does not tell the subscriber terminals what epoch it may communicate in. This process is described in more detail by the flow chart of FIG. 52, which is one example of implementation of step 1514 of FIG. 50. In step 1560, the subscriber terminal is always looking for the header of a super-frame in the down link. The header contains a unique sequence of bits. Therefore, in one embodiment, the subscriber terminal does not need to know the hopping plan because the subscriber terminal is always looking for the unique sequence of bits. When the subscriber terminal's beam is not active, the subscriber terminal will not see that unique sequence of bits. In step 1562, the subscriber terminal detects the header of the super-frame in

the down link. In step 1564, the subscriber terminal uses the symbol phases in the header to adjust its clocking/timing so that the subscriber terminal is now in synchronization with the gateway. In some cases, the gateway will include clock information, date information or other timing information in the payload of the super-frame. If the time of day is in the super-frame, then the subscriber terminal will calculate the current time of day from the subscriber terminal based on the time of day in the super-frame and transmission delay. In step 1570, the calculated current time is used to adjust the clock for the subscriber terminal. If the time of day is not in the super-frame, then no further adjustment is made to the timing (step 1572).

In one embodiment, the gateway will instruct the subscriber terminal when to transmit on the up link and what frequency to use. This will enable the subscriber terminal to transmit when its hopping beam is active, without having to know the full hopping plan.

In one embodiment, when a subscriber terminal is connected to multiple gateways, the subscriber terminal establishes independent timing even if the gateways are communicating over the same satellite. Thus, a first gateway and a second gateway connected to the same subscriber terminal via the same satellite are configured to establish independent (ie separate) timing with the subscriber terminal.

Note that in the above discussion of FIG. 51, the gateway used ephemeris data to calculate the satellite's current location. FIG. 53 is a flow chart describing one embodiment for a plurality of gateways to determine ephemeris data for a satellite. The process of FIG. 53 can be performed for each satellite multiple times day. In step 1580, multiple gateways receive a GPS signal from the multiple GPS satellites. In step 1582, these gateways will identify GPS time based on those received GPS signals using known methods. In step 1584, the multiple gateways will receive the beacon signal from a particular satellite. Each of the gateways will determine the time of receipt of that beacon signal in GPS time. All the gateways transmit (via the internet or other network) their receive times (in GPS time) of that beacon signal to other gateways. Each of the gateways calculate the location and velocity of the satellite based on the beacon signal received times at each gateway and the known locations of each gateway. This assumes that the gateways are not mobile. This process can also make use for multiple samples of the beacon signal. By knowing the location of a gateway and the time it took to transmit a beacon signal from the satellite to the gateway, it can be calculated how far the satellite is from the gateway. That creates a sphere around the gateway where the satellite can be anywhere on the surface of that sphere. But knowing that sphere from multiple gateways, there will be an intersection point that intersects all the spheres, which represents the location of the satellite at the moment and time. By calculating the satellite at multiple times, the satellite location and velocity can be calculated. By knowing the proposed orbit and a bunch of samples of location and velocity, the gateway can predict the location of the satellite at any given time. If the process of FIG. 53 is performed multiple times a day, then the gateway's ephemeris data will remain current.

One embodiment also includes determining the Doppler to the satellite including receiving the beacon signal at the ground based gateway, determining frequency offset over time of the beacon signal at the ground based gateway; and calculating Doppler to the satellite using the history of the beacon signal frequency offset.

As described above, in one embodiment, the non-geostationary satellites are configured to provide steerable gateway beams and non-articulated gateway beams. The non-geostationary satellite includes a beam hopping plan for the plurality of spot beams using time domain beam hopping, a beam steering plan for the steerable gateway beams, a steering plan for the high capacity beams and a connectivity plan for on-board routing between the gateway beams and the plurality of spot beams using time domain beam hopping. The hopping plan and the connectivity plan are structured as a sequence of epochs.

In some embodiments the satellite clock is adjusted during the reconfiguration time, and/or the clock on the satellite is adjusted by a terrestrial location (e.g., network control center 230, a gateway or other terrestrial location) in burst of small increments periodically while the satellite is in view.

Note that the discussion above introduces many different features and many embodiments. It is to be understood that the above-described embodiments are not all mutually exclusive. That is, the features described above (even when described separately) can be combined in one or multiple embodiments.

One embodiment includes a method of operating a satellite communications system, comprising: accessing master clock information at a terrestrial location; transmitting a timing message based on the master clock information from the terrestrial location to a satellite as the satellite is in orbit; synchronizing the satellite to the master clock based on the timing message; transmitting a beacon signal from the satellite, the beacon signal includes timing information; receiving the beacon signal at a ground based gateway; synchronizing the gateway to the satellite based on the beacon signal; sending communication from the gateway to a terminal via the satellite, the communication includes timing data; and synchronizing the terminal to the gateway based on the timing data.

One embodiment includes a satellite communication system, comprising: a satellite comprising an antenna system configured to receive command information from a ground location and transmit a beacon signal toward a ground based gateway, the command information includes a command to adjust a clock on the satellite to synchronize the satellite to a master clock, the beacon signal includes timing information to synchronize the gateway to the satellite.

One embodiment includes a satellite based communication system, comprising: a gateway configured to communicate with a terminal via the satellite, the gateway is configured to receive a beacon signal from the satellite and synchronize to the satellite based on the beacon signal, the gateway configured to send communication to the terminal via the satellite, the communication with the terminal includes timing data for the terminal to synchronize to the gateway.

For purposes of this document, it should be noted that the dimensions of the various features depicted in the figures may not necessarily be drawn to scale.

For purposes of this document, reference in the specification to "an embodiment," "one embodiment," "some embodiments," or "another embodiment" may be used to describe different embodiments or the same embodiment.

For purposes of this document, a connection may be a direct connection or an indirect connection (e.g., via one or more other parts). In some cases, when an element is referred to as being connected or coupled to another element, the element may be directly connected to the other element or indirectly connected to the other element via

intervening elements. When an element is referred to as being directly connected to another element, then there are no intervening elements between the element and the other element. Two devices are "in communication" if they are directly or indirectly connected so that they can communicate electronic signals between them.

For purposes of this document, the term "based on" may be read as "based at least in part on."

For purposes of this document, without additional context, use of numerical terms such as a "first" object, a "second" object, and a "third" object may not imply an ordering of objects, but may instead be used for identification purposes to identify different objects.

For purposes of this document, the term "set" of objects may refer to a "set" of one or more of the objects.

The foregoing detailed description has been presented for purposes of illustration and description. It is not intended to be exhaustive or to limit the subject matter claimed herein to the precise form(s) disclosed. Many modifications and variations are possible in light of the above teachings. The described embodiments were chosen in order to best explain the principles of the disclosed technology and its practical application to thereby enable others skilled in the art to best utilize the technology in various embodiments and with various modifications as are suited to the particular use contemplated. It is intended that the scope of be defined by the claims appended hereto.

What is claimed is:

1. A method of operating a satellite communications system, comprising:
 - accessing master clock information at a terrestrial location;
 - transmitting a timing message based on the master clock information from the terrestrial location to a satellite as the satellite is in orbit;
 - synchronizing the satellite to the master clock information based on the timing message;
 - transmitting a beacon signal from the satellite, the beacon signal includes timing information based on the synchronizing of the satellite, the transmitted timing information including pulses each representing timing of a respective one of data communication epochs of the satellite;
 - receiving the beacon signal at a ground based gateway;
 - synchronizing the gateway to the satellite based on the beacon signal;
 - sending communication from the synchronized gateway to a terminal via the satellite during one or more of the data communication epochs of the satellite, the communication includes timing data; and
 - synchronizing the terminal to the synchronized gateway based on the timing data.
2. The method of claim 1, wherein:
 - the timing message includes a command to set a clock on the satellite.
3. A method of operating a satellite communications system, comprising:
 - accessing master clock information at a terrestrial location;
 - transmitting a timing message based on the master clock information from the terrestrial location to a satellite as the satellite is in orbit;
 - synchronizing the satellite to the master clock information based on the timing message;
 - transmitting a beacon signal from the satellite, the beacon signal includes timing information based on the synchronizing of the satellite;

39

receiving the beacon signal at a ground based gateway;
synchronizing the gateway to the satellite based on the
beacon signal;
sending communication from the synchronized gate-
way to a terminal via the satellite, the communica- 5
tion includes timing data; and
synchronizing the terminal to the synchronized gate-
way based on the timing data;
wherein the satellite is a non-geostationary satellite
having a plurality of non-articulating beam provid- 10
ing antennas whose operations are switched in accord-
ance with a time domain beam hopping plan; and
wherein for each orbit, the beacon signal indicates
timing of an epoch for the time domain beam hop- 15
ping plan and indicates a quantity of epochs from a
time reference.

4. The method of claim 1, wherein:
the satellite receives the timing message as the satellites
travels in orbit closest to the terrestrial location. 20

5. The method of claim 1, wherein:
the satellite is a non-geostationary satellite.

6. The method of claim 1, wherein:
the terminal synchronizes to the gateway while commu- 25
nicating user data with the gateway.

7. The method of claim 5, wherein said transmitting the
beacon signal from the satellite comprises transmitting the
beacon signal such that the beacon signal is received and can
be processed at the gateway ahead of ability by the gateway 30
to receive other signals beamed from the satellite, the
method further comprising:
establishing further communication between the gateway
and the satellite to implement connections between the
gateway and a plurality of terminals via the satellite 35
after the beacon signal is received and processed for
synchronizing the gateway to the satellite for a current
orbit.

8. The method of claim 1, wherein:
the sending communication from the gateway to the 40
terminal includes sending a frame, the timing data is in
the frame.

9. The method of claim 1, wherein:
the synchronizing the gateway to the satellite based on the
beacon signal comprises using a location of the satellite 45
and a location of the gateway to determine a transmis-
sion delay of the beacon signal and adjusting timing in
the gateway based on the pulses in the timing infor-
mation of the beacon signal and the determined transmis-
sion delay. 50

10. The method of claim 9, further comprising:
determining the location of the satellite including:
receiving GPS signals at a first ground based gateway;
receiving the beacon signal at the first ground based
gateway; 55
determining time of receipt in GPS time of a predeter-
mined part of the beacon signal at the first ground based
gateway such that travel distance of the beacon signal
from the satellite to the first ground based gateway can
be determined based on said time of receipt in GPS 60
time; and
calculating location of the satellite using the time of
receipt in GPS time of the predetermined part of the
beacon signal at the first ground based gateway and
using the time of receipt in GPS time of the predeter- 65
mined part of the beacon signal at multiple other
ground based gateways.

40

11. The method of claim 9, further comprising
determining the Doppler to the satellite including receiv-
ing the beacon signal at the ground based gateway,
determining frequency offset over time of the beacon
signal at the ground based gateway; and calculating
Doppler to the satellite using the history of the beacon
signal frequency offset.

12. The method of claim 9, further comprising determin-
ing the location of the satellite including:
respectively receiving GPS signals at respective ones of
multiple ground based gateways;
respectively identifying GPS time at the multiple gate-
ways based on the respectively received GPS signals;
receiving the beacon signal at the multiple ground based
gateways; 15
determining respective times of receipt in GPS time of a
predetermined part of the beacon signal at the respec-
tive multiple ground based gateways; and
calculating location of the satellite using the respective
times of receipt in GPS time of the predetermined part
of the beacon signal at the respective multiple ground
based gateways.

13. A satellite communication system, comprising:
a non-geostationary satellite orbiting in a predetermined
direction and comprising an antenna system configured
to receive command information from a ground loca-
tion and responsive to the command information, to
synchronize itself to a predetermined system timing
reference and to transmit a beacon signal in the prede-
termined direction toward a ground based gateway such
that such that for each orbit the beacon signal is
received at the gateway ahead of receiving other signals
at the gateway from the satellite, the received beacon
signal providing timing information for synchronizing
the gateway to the predetermined system timing refer-
ence, the command information includes a command to
adjust a clock on the satellite to synchronize the satel-
lite to a master clock, the beacon signal including the
timing information to synchronize the gateway to data
communication epochs of the satellite and to the pre-
determined system timing reference before the gateway
receives other signals from the satellite, the timing
information including pulses each representing timing
of a respective one of data communication epochs of
the satellite and message blocks each indicating how
far past the predetermined system timing reference are
corresponding ones of the satellite epochs represented
the pulses associated with the corresponding message
block.

14. The satellite communication system of claim 13,
wherein:
the non-geostationary satellite has a plurality of non-
articulating beam providing antennas whose operations
are switched in accordance with a time domain beam
hopping plan; 55
the satellite clock is adjusted during a predetermined
reconfiguration time; and
for each orbit, the beacon signal indicates timing of
epochs between which switching between beams can
be performed in accordance with the time domain beam
hopping plan and indicates a quantity of epochs passed
from the predetermined system timing reference.

15. The satellite communication system of claim 13,
wherein:
the clock on the satellite is adjusted by the terrestrial
location in bursts of small increments periodically
while the satellite is in view for the terrestrial location.

41

16. The satellite communication system of claim 13, further comprising:

the gateway, and wherein said synchronizing of the gateway to the satellite includes using a location of the satellite and a location of the gateway to determine a transmission delay of the beacon signal and adjusting timing on the gateway based on the timing information in the beacon signal and the transmission delay.

17. The satellite communication system of claim 16, wherein:

the gateway is configured to determine the location of the satellite by working with other gateways to receive GPS signals at multiple ground based gateways, identify GPS time at the multiple gateways, receive the beacon signal at the multiple ground based gateways, determine respective times of receipt in GPS time of a predetermined part the beacon signal at respective ones of the multiple ground based gateways and calculate location of the satellite using the times of receipt in GPS time of the predetermined part the beacon signal at the multiple ground based gateways.

18. A satellite based communication system, comprising: a ground-based gateway configured to communicate with a ground-based terminal via an in-view non-geostationary satellite orbiting in a predetermined direction and projecting a beacon signal for ground receipt ahead of other signals provided by the satellite, the beacon signal including pulses each representing timing of a respective one of data communication epochs of the satellite, the gateway is configured to receive the projected beacon signal from the satellite ahead of other signals provided by the satellite and to synchronize to the satellite based on the pulses in the beacon signal, the gateway being configured to send communication to the terminal via the satellite during one or more of the data communication epochs of the satellite and after being synchronized to the satellite, the communication with the terminal includes timing data for the terminal to synchronize to the synchronized gateway.

19. The satellite communication system of claim 18, wherein:

the non-geostationary satellite has a plurality of non-articulating beam providing antennas whose operations are switched in accordance with a time domain beam hopping plan; and

for each orbit, the beacon signal indicates timing of an epoch for the time domain beam hopping plan and indicates a quantity of epochs from a time reference.

20. The satellite communication system of claim 18, wherein:

the gateway is configured to establish communication between the gateway and the satellite to implement connections between the gateway and a plurality of terminals via the satellite, the gateway configured to synchronize to the satellite based on the beacon signal before the establishing communication for a current orbit.

42

21. The satellite communication system of claim 18, wherein:

the gateway is configured to synchronize to the satellite based on the beacon signal by using a location of the satellite and a location of the gateway to determine a transmission delay of the beacon signal and adjusting timing on the gateway based on the timing information in the beacon signal and the transmission delay.

22. The satellite communication system of claim 21, wherein:

the gateway is configured to determine the location of the satellite by working with other gateways to receive GPS signals at multiple ground based gateways, identify GPS time at the multiple gateways, receive the beacon signal at the multiple ground based gateways, determine times of receipt in GPS time of the beacon signal at the multiple ground based gateways and calculate location of the satellite using the times of receipt in GPS time of the beacon signal at the multiple ground based gateways.

23. The satellite communication system of claim 18, wherein:

an additional gateway is used, the gateway and the additional gateway are connected to the terminal via the satellite, the gateway and the additional gateway are configured to establish independent timing with the terminal.

24. The method of claim 1, wherein:

said sending of communication from the synchronized gateway to a terminal via the satellite and in accordance with the data communication epochs of the satellite includes allowing for switching of beams used for the communication between the epochs in accordance with a current time domain beam hopping plan of the satellite.

25. The method of claim 24, wherein:

said sending of communication from the synchronized gateway to a terminal via the satellite and in accordance with the data communication epochs of the satellite includes allowing for switching to a different current time domain beam hopping plan between the epochs.

26. The method of claim 1, wherein:

the master clock information is based on a predetermined system timing reference for the satellite communications system;

the transmitted timing information includes repeatedly inserted message blocks each indicating how far past the predetermined system timing reference are corresponding ones of the satellite epochs represented the pulses associated with the corresponding message block; and

said sending of communication from the synchronized gateway to a terminal via the satellite and in accordance with the data communication epochs of the satellite includes allowing for switching to different current time domain beam hopping plans between the epochs is based on how far past the predetermined system timing reference are corresponding ones of the satellite epochs.

* * * * *