

US010402782B2

(12) **United States Patent**
Moore et al.

(10) **Patent No.:** **US 10,402,782 B2**
(45) **Date of Patent:** **Sep. 3, 2019**

(54) **SYSTEMS AND METHODS FOR AND DISPLAYING PATIENT DATA**

(71) Applicant: **AirStrip IP Holdings, LLC**, San Antonio, TX (US)
(72) Inventors: **Stephen Trey Moore**, San Antonio, TX (US); **Thomas Scott Wade**, Wimberley, TX (US); **Lloyd Kory Brown**, San Antonio, TX (US)
(73) Assignee: **AirStrip IP Holdings, LLC**, San Antonio, TX (US)

(*) Notice: Subject to any disclaimer, the term of this patent is extended or adjusted under 35 U.S.C. 154(b) by 193 days.

(21) Appl. No.: **13/798,580**

(22) Filed: **Mar. 13, 2013**

(65) **Prior Publication Data**

US 2013/0275151 A1 Oct. 17, 2013

Related U.S. Application Data

(60) Provisional application No. 61/624,954, filed on Apr. 16, 2012.

(51) **Int. Cl.**
G06Q 10/10 (2012.01)
G06Q 50/24 (2012.01)
(Continued)

(52) **U.S. Cl.**
CPC **G06Q 10/10** (2013.01); **G06F 19/3418** (2013.01); **G06Q 50/24** (2013.01);
(Continued)

(58) **Field of Classification Search**
CPC G06Q 50/24; G06Q 10/00; G06Q 50/22; G06F 19/322; G06F 19/324; G06F 17/30064
(Continued)

(56) **References Cited**

U.S. PATENT DOCUMENTS

3,893,453 A 7/1975 Goldberg et al.
4,340,065 A 7/1982 Gessman

(Continued)

FOREIGN PATENT DOCUMENTS

JP H02111341 A 9/1990
JP 2003135415 A 5/2003

(Continued)

OTHER PUBLICATIONS

Sundvall, Erik, et al. "Graphical overview and navigation of electronic health records in a prototyping environment using Google Earth and openEHR archetypes." Medinfo 2007: Proceedings of the 12th World Congress on Health (Medical) Informatics; Building Sustainable Health Systems. IOS Press, 2007.*

(Continued)

Primary Examiner — Mark Holcomb

(74) *Attorney, Agent, or Firm* — Fish & Richardson P.C.

(57) **ABSTRACT**

Methods, systems, and apparatus, including computer programs encoded on a computer storage medium, for receiving user input, the user input indicating a user command to display a timeline screen, in response to the user input, processing patient-specific data to determine one or more medical events to be graphically depicted, the one or more medical events being specific to a patient, and displaying the timeline screen on the mobile device, the timeline screen displaying a timeline associated with the patient and comprising at least a portion of the one or more medical events, each medical event comprising summary information, the one or more medical events being displayed in chronological order.

17 Claims, 14 Drawing Sheets

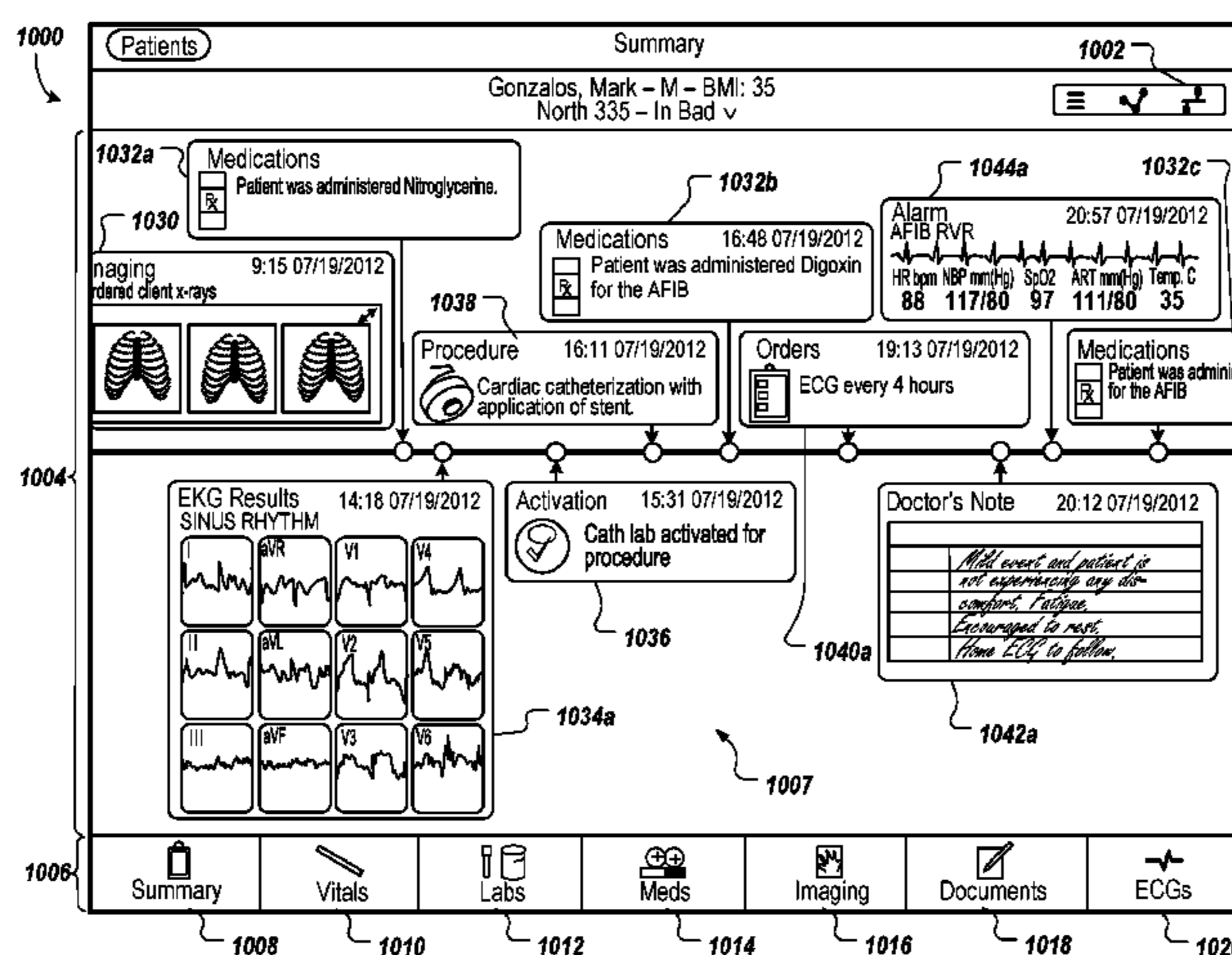

- (51) **Int. Cl.**
G06F 19/00 (2018.01)
G16H 40/63 (2018.01)
G16H 10/60 (2018.01)
G16H 15/00 (2018.01)
- (52) **U.S. Cl.**
 CPC **G16H 10/60** (2018.01); **G16H 15/00**
 (2018.01); **G16H 40/63** (2018.01)
- (58) **Field of Classification Search**
 USPC 705/2-4; 707/746
 See application file for complete search history.

(56) **References Cited**

U.S. PATENT DOCUMENTS

4,873,987	A	10/1989	Djordjevich	
4,896,677	A	1/1990	Kaneko et al.	
4,989,610	A	2/1991	Patton et al.	
5,447,164	A	9/1995	Shaya et al.	
5,788,646	A	8/1998	Fuchs	
6,007,491	A	12/1999	Ling	
6,621,508	B1 *	9/2003	Shiraishi et al.	715/810
7,171,630	B2	1/2007	O'Leary	
7,227,549	B2	6/2007	Beasley et al.	
8,209,002	B2	6/2012	Vajdic et al.	
9,524,569	B2	12/2016	Moore et al.	
2001/0017707	A1	8/2001	Lee	
2002/0154111	A1	10/2002	Webb	
2002/0198473	A1	12/2002	Kumar	
2004/0054294	A1	3/2004	Ramseth	
2004/0102710	A1	5/2004	Kim	
2004/0204635	A1	10/2004	Scharf et al.	
2006/0149597	A1 *	7/2006	Powell et al.	705/2
2006/0264769	A1	11/2006	Satin	
2006/0265249	A1 *	11/2006	Follis et al.	705/3
2007/0156966	A1	7/2007	Sundarrajan	
2007/0162424	A1	7/2007	Jeh	
2007/0191721	A1	8/2007	Parker	
2007/0191740	A1	8/2007	Shertukde et al.	
2008/0114808	A1 *	5/2008	Morita et al.	707/104.1
2009/0076402	A1	3/2009	Hoiium et al.	
2009/0222286	A1	9/2009	Elsholz	
2009/0241048	A1 *	9/2009	Augustine	G06Q 10/10 715/769
2009/0292180	A1	11/2009	Mirow	
2010/0198619	A1 *	8/2010	Whelchel	G06Q 10/06 705/3
2010/0235782	A1 *	9/2010	Powell et al.	715/809
2011/0092838	A1	4/2011	Helfenbein	
2011/0251960	A1	10/2011	Holla	
2011/0301478	A1 *	12/2011	Ben-Sira	A61B 5/0402 600/515
2012/0075103	A1	3/2012	Powell	
2012/0101398	A1	4/2012	Ramanathan et al.	
2012/0123223	A1	5/2012	Freeman et al.	
2012/0130741	A1 *	5/2012	Sparandara et al.	705/3
2012/0131495	A1	5/2012	Goossens et al.	
2012/0206475	A1	8/2012	Bryant et al.	
2013/0024206	A1 *	1/2013	Hughes et al.	705/3
2013/0271469	A1	10/2013	Moore	
2013/0271470	A1	10/2013	Moore	
2013/0275152	A1	10/2013	Moore	

FOREIGN PATENT DOCUMENTS

JP	2003284698	10/2003
JP	2004174230	6/2004
JP	2004261583	A 9/2004
JP	2007190227	8/2007
JP	2009518732	A 5/2009
JP	2010214016	A 9/2010
JP	2011233161	A 11/2011
JP	2012529351	A 11/2012
JP	2013527503	A 6/2013
WO	WO2010054409	A1 5/2010

WO	WO2010058139	5/2010
WO	WO2011122404	10/2011
WO	WO2013158625	A1 10/2013
WO	WO2013158632	A1 10/2013

OTHER PUBLICATIONS

Authorized Officer Simin Baharlou, International Preliminary Report on Patentability for International Application No. PCT/US2013/036769, dated Oct. 30, 2014, 7 pages.

Authorized Officer Mineko Mohri, International Preliminary Report on Patentability for International Application No. PCT/US2013/036758, dated Oct. 30, 2014, 21 pages.

Google Search: Waveform Display and Strip Stack and Scale, Dec. 11, 2014, 2 pages.

National Instruments, "Customizing Graphs and Charts," LabVIEW 2011 Help, Jun. 2011, 10 pages.

Kissei America, Inc., "SleepSign Analysis Program," available online since May 6, 2006, <http://web.archive.org/web/20060506174919/http://www.sleepsign.com/dataAnalysis.html>, 4 pages.

Omega's Electronics, "Agilent Technologies," available online since Aug. 31, 2011, <https://omegacs.wordpress.com/>, 1 page.

Agilent Technologies, Inc., "Generating Complex ECG Patterns with an Arbitrary Waveform Generator," Measurement Tips, vol. 10, No. 3, Jul. 1, 2010, 4 pages.

Plaintiffs' Complaint for Patent Infringement, *Airstrip Technologies, Inc. et al. v. mVISUM, Inc.*, Civil Action No. 1:12-cv-07776-JFK, United States District Court for the Southern District of New York, Document 1, filed Oct. 18, 2012, 30 pages.

Defendant's Answer and Counterclaim, *Airstrip Technologies, Inc. et al. v. mVISUM, Inc.*, Civil Action No. 1:12cv-07776-JFK, United States District Court for the Southern District of New York, Document 29, filed Apr. 5, 2013, 13 pages.

GE Healthcare, "Web Viewer and Pocket Viewer," 2007, retrieved from <http://www3.gehealthcare.com/~media/Downloads/us/Product/Product-Categories/Patient-Monitoring/Careports/Mobile-Viewers/GEHealthcare-Web-Viewer-Pocket-Viewer-ProductSpec.pdf?Parent=%7B1ED25767-3F69-413B-8C56-3DDEA5CEF31F%7D>, 4 pages.

Edward H. Schmuhl et al., "HP PalmVue: A New Healthcare Information Product," Hewlett-Packard Journal, Article 8, Jun. 1996, retrieved from <http://www.hpl.hp.com/hpjournal/96jun/jun96a8.pdf>, pp. 12-17.

MobileInfo, "Data Critical's StatView™ Alarm Notification System," Jun. 2000, retrieved from http://www.mobileinfo.com/Applications_Vertical/Healthcare_Applications/StatView.htm, 2 pages.

Telecompaper, "Data Critical Launches Rhythmstat XL Medical System," Jan. 8, 1998, retrieved from <http://www.telecompaper.com/news/data-critical-launches-rhythmstat-xl-medical-system-26725>, 2 pages.

U.S. Food and Drug Administration, Protecting and Promoting Your Health, "MAUDE Adverse Event Report: Data Critical Corp. Impactpaging System," Nov. 19, 2000, retrieved on Apr. 8, 2013 from www.accessdata.fda.gov/scripts/cdrh/cfdocs/cfmaude/detail.cfm?mdrfoi_id=312735, 2 pages.

Department of Health & Human Services, Food and Drug Administration, Center for Devices and Radiological Health, 510(k) Summary and approval letter for FlexView™ Clinical Monitoring System (K003998), Mar. 7, 2001, 4 pages.

Department of Health & Human Services, Food and Drug Administration, Center for Devices and Radiological Health, 510(k) Summary and approval letter for AlarmView™ Wireless Data Network System (K010912), Apr. 5, 2001, 4 pages.

Department of Health & Human Services, Food and Drug Administration, Center for Devices and Radiological Health, 510(k) Summary and approval letter for Agilent Information Center (AIC) Software Release D.0 (K011093), May 1, 2001, 5 pages.

Department of Health & Human Services, Food and Drug Administration, Center for Devices and Radiological Health, 510(k) Summary and approval letter for Mobile-PatientViewer™ (K011436), Jul. 5, 2001, 5 pages.

Department of Health & Human Services, Food and Drug Administration, Center for Devices and Radiological Health, 510(k) Sum-

(56)

References Cited

OTHER PUBLICATIONS

mary and approval letter for FlexView™ Clinical Monitoring System (K011999), Jul. 24, 2001, 4 pages.

Department of Health & Human Services, Food and Drug Administration, Center for Devices and Radiological Health, 510(k) Summary and approval letter for AlarmView™ Wireless Data Network System (K012005), Jul. 24, 2001, 4 pages.

Department of Health & Human Services, Food and Drug Administration, Center for Devices and Radiological Health, 510(k) Summary and approval letter for AlarmView™ Wireless Data Network System (K013156), Oct. 19, 2001, 4 pages.

Department of Health & Human Services, Food and Drug Administration, Center for Devices and Radiological Health, 510(k) Summary and approval letter for Datex-Ohmeda S/5 Web Viewer, Datex-Ohmeda S/5 Pocket Viewer and Datex-Ohmeda S/5 Cellular Viewer with L-WEB04 software (K052975), Jan. 20, 2006, 7 pages.

Department of Health & Human Services, Food and Drug Administration, Center for Devices and Radiological Health, 510(k) Summary and approval letter for Web Viewer, Pocket Viewer and Cellular Viewer with L-WEB05 software (K061994), Aug. 11, 2006, 4 pages.

Department of Health & Human Services, Food and Drug Administration, Center for Devices and Radiological Health, 510(k) Summary and approval letter for RhythmStat XL System (K971650), Dec. 4, 1997, 9 pages.

Department of Health & Human Services, Food and Drug Administration, Center for Devices and Radiological Health, 510(k) Summary and approval letter for Cardio-Pager™ System (K973527), Mar. 31, 1998, 6 pages.

Department of Health & Human Services, Food and Drug Administration, Center for Devices and Radiological Health, 510(k) Summary and approval letter for Hewlett-Packard M2605A Viridia Wave Viewer (K974567), Jan. 20, 1998, 5 pages.

Department of Health & Human Services, Food and Drug Administration, Center for Devices and Radiological Health, 510(k) Summary and approval letter for StatView™ System (K990378), Sep. 20, 1999, 6 pages.

Department of Health & Human Services, Food and Drug Administration, Center for Devices and Radiological Health, 510(k) Summary and approval letter for AlarmView™ System (K992848), Nov. 19, 1999, 6 pages.

Authorized Officer Blaine R. Copenheaver, International Search Report and Written Opinion of the International Searching Authority for International Application No. PCT/US2013/036758, dated Jun. 28, 2013, 24 pages.

Airstriptechn. Airstrip Cardiology iPad Demo. May 2011. [retrieved on Jun. 24, 2013]. Retrieved from the Internet: <URL:http://www.youtube.com/watch?v=6V15m9A4wd0>. entire document.

Authorized Officer Blaine R. Copenheaver, International Search Report and Written Opinion of the International Searching Authority for International Application No. PCT/US2013/036769, dated Aug. 28, 2013, 13 pages.

PRWeb, Cardio Calipers Software from Iconico Released; the On-Screen Electrocardiogram (EKG, ECG) Measurement Software for Windows, PRWeb. Mar. 21, 2006. (Retrieved on: Aug. 13, 2013). Retrieved from internet: <URL:http://www.pnweb.com/pdfdownload/361236.pdf>, entire document.

Roberts Blog, "Freeing the axes of the Microsoft toolkit charting control," retrieved from <http://reyntjes.blogspot.com/2009/09/freeing-axes-of-microsoft-toolkit.html>, posted on-line Sep. 15, 2009, 8 pages.

Extended European Search Report for Application No. 13777472.5, dated Jan. 26, 2016, 9 pages.

Steven Elbinger et al: USPTO Office Action for U.S. Appl. No. 13/863,840, dated Jun. 3, 2015, 23 pages.

Supplementary European Search Report for Application No. 13778942.6, dated Oct. 6, 2015, 2 pages.

Supplementary European Search Report for Application No. 13777472.5, dated Oct. 6, 2015, 4 pages.

European Examination and Supplementary Search Report for Application No. 13778942.6, dated Oct. 23, 2015, 6 pages.

Examination Report for Canadian Application No. 2,869,632, dated Jan. 3, 2019, 4 pages.

Examination Report for Canadian Application No. 2,870,560, dated Jan. 3, 2019, 4 pages.

European Examination and Report for Application No. 13777472.5, dated Aug. 2, 2016, 6 pages.

Google patents search: displaying folded pages and animated, Jun. 30, 2016, 2 pages.

Notice of Reasons for Rejection for Japanese Patent Application No. 2015-507108, dated Nov. 7, 2016, 4 pages.

Examination Report for Australian Patent Application No. 2013249417, dated Jan. 23, 2017, 4 pages.

Examination Report for Australian Patent Application No. 2013249417, dated Aug. 31, 2017, 4 pages.

Decision to Grant a Patent for Japanese Patent Application No. 2015-507108, dated Sep. 28, 2017, 3 pages.

Examination Report for Australian Patent Application No. 2013249502, dated Jul. 28, 2017, 4 pages.

Examination Report for Australian Patent Application No. 2013249502, dated Aug. 30, 2017, 4 pages.

Notice of Reasons for Rejection for Japanese Patent Application No. 2015-507107, dated Apr. 10, 2017, 15 pages.

Notice of Reasons for Rejection for Japanese Patent Application No. 2015-507107, dated Jan. 22, 2018, 8 pages.

Decision to Dismiss the Amendment for Japanese Patent Application No. 2015-507107, dated Aug. 22, 2018, 8 pages.

* cited by examiner

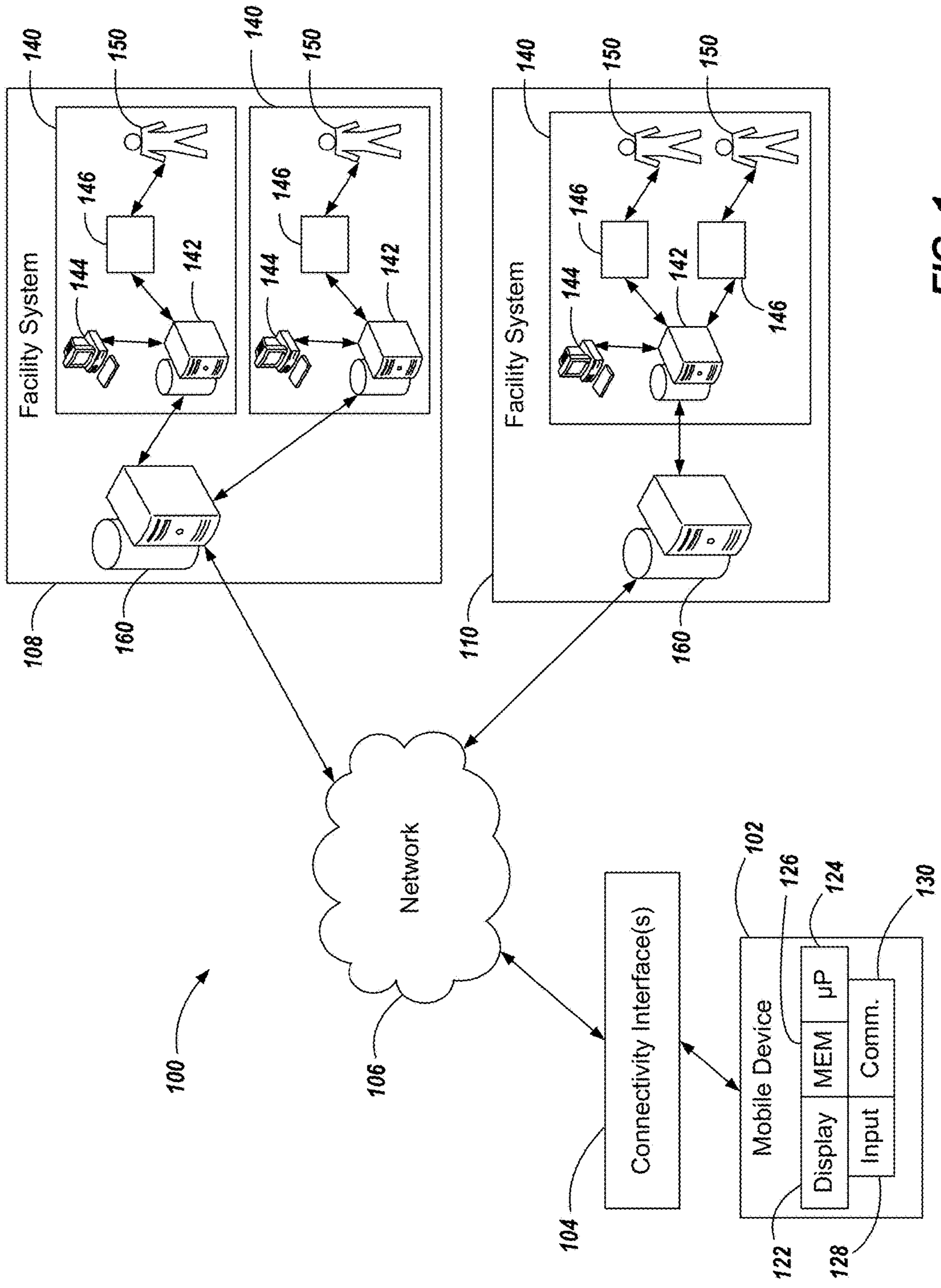

FIG. 1

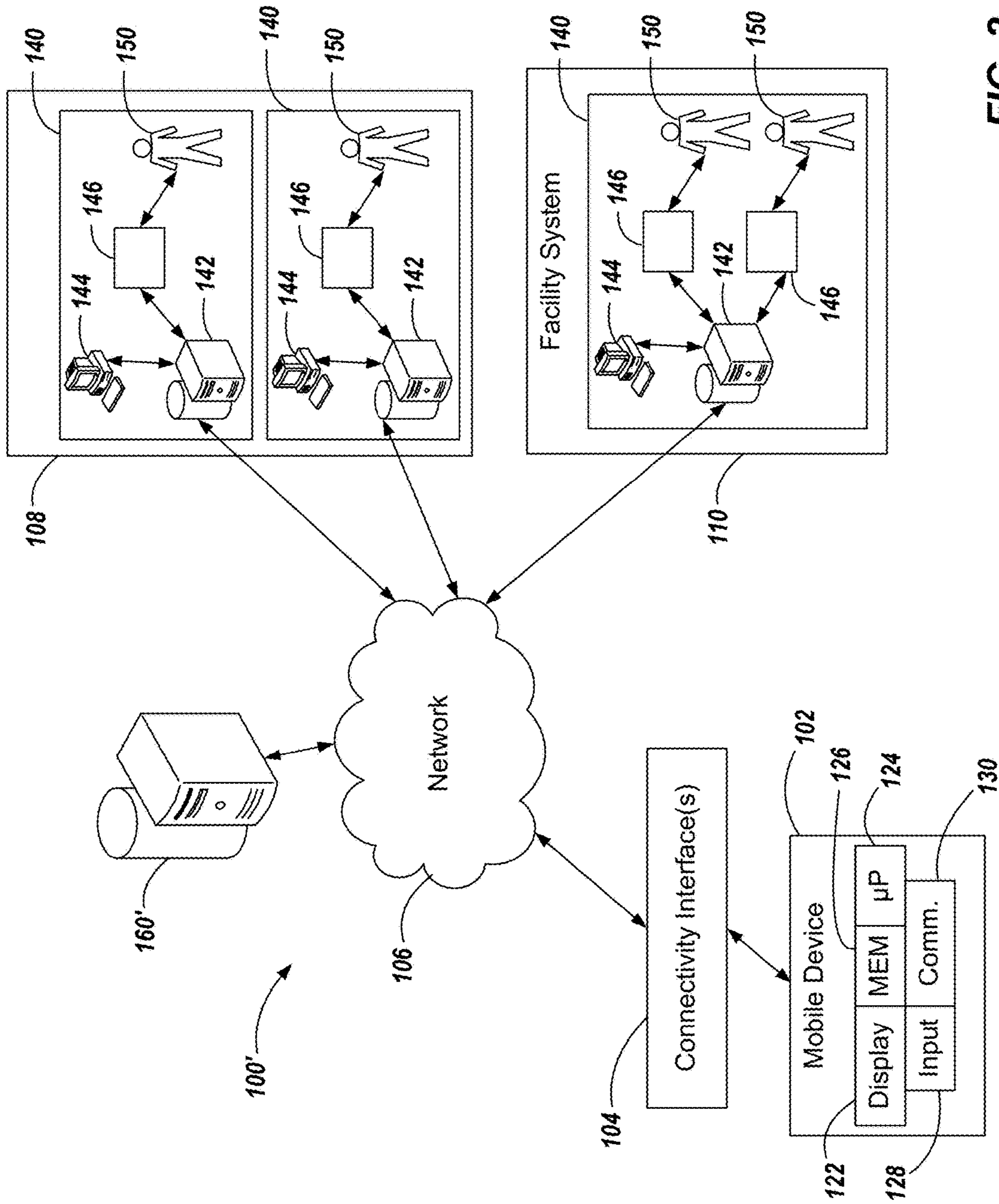
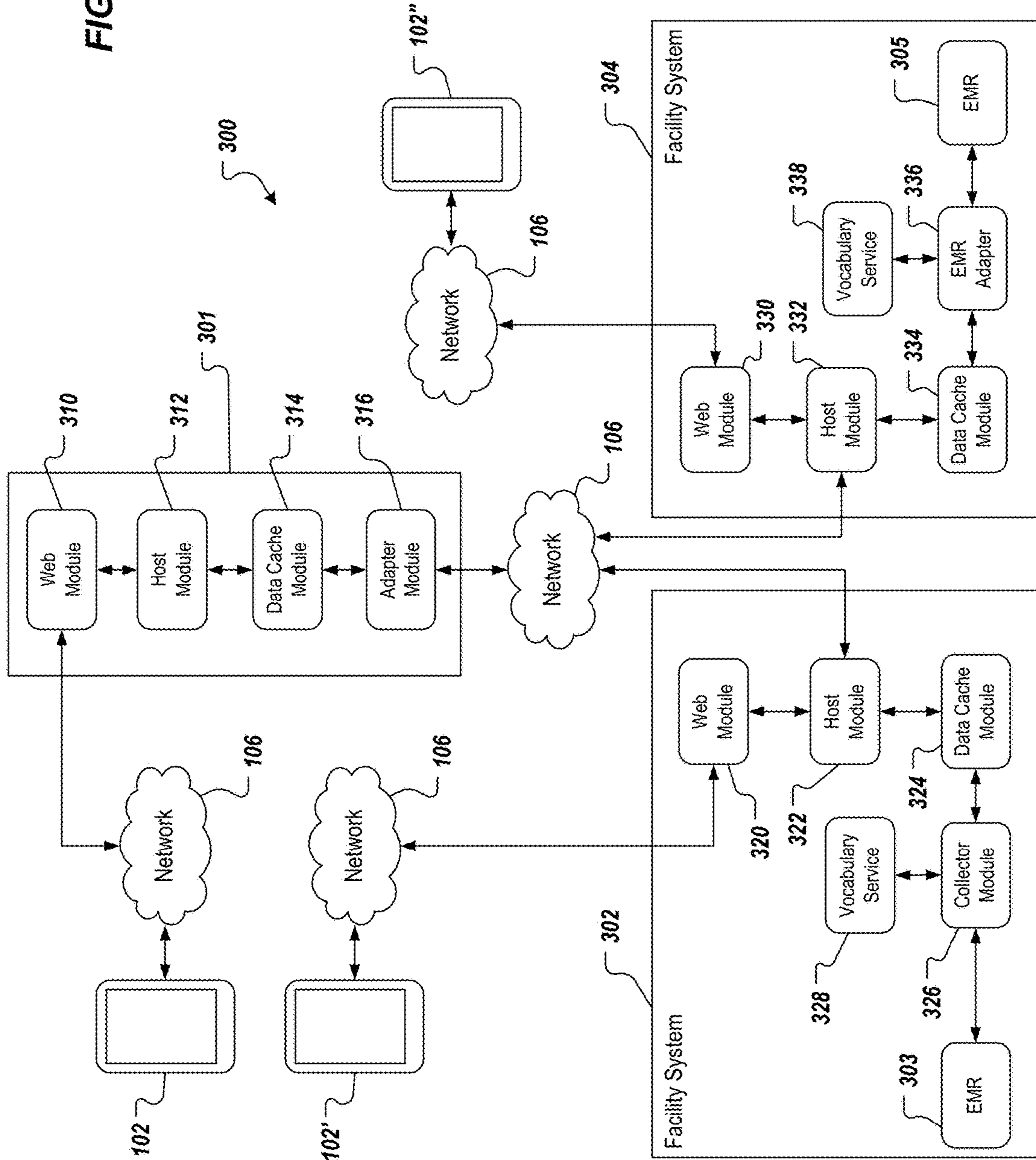

FIG. 2

FIG. 3



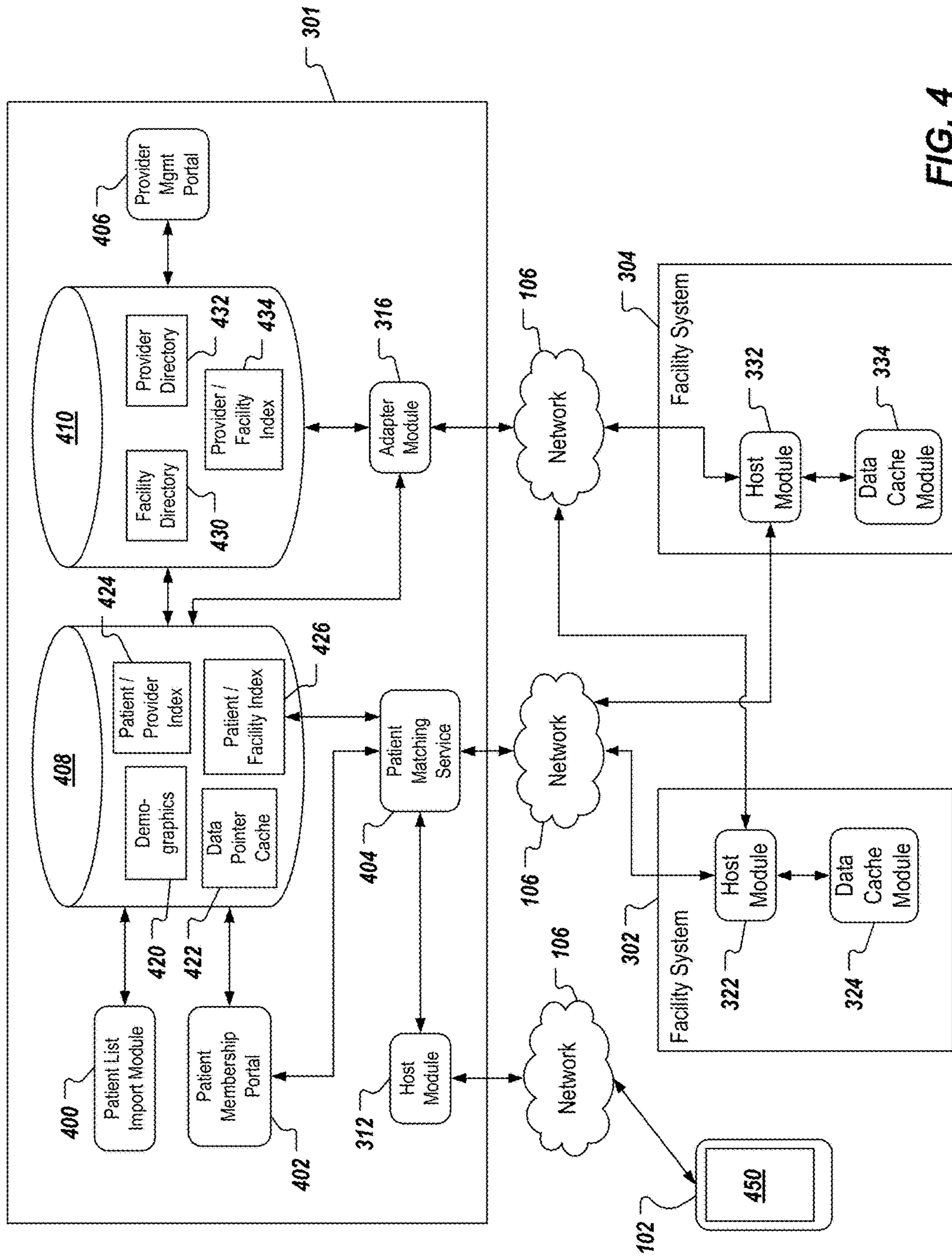

FIG. 4

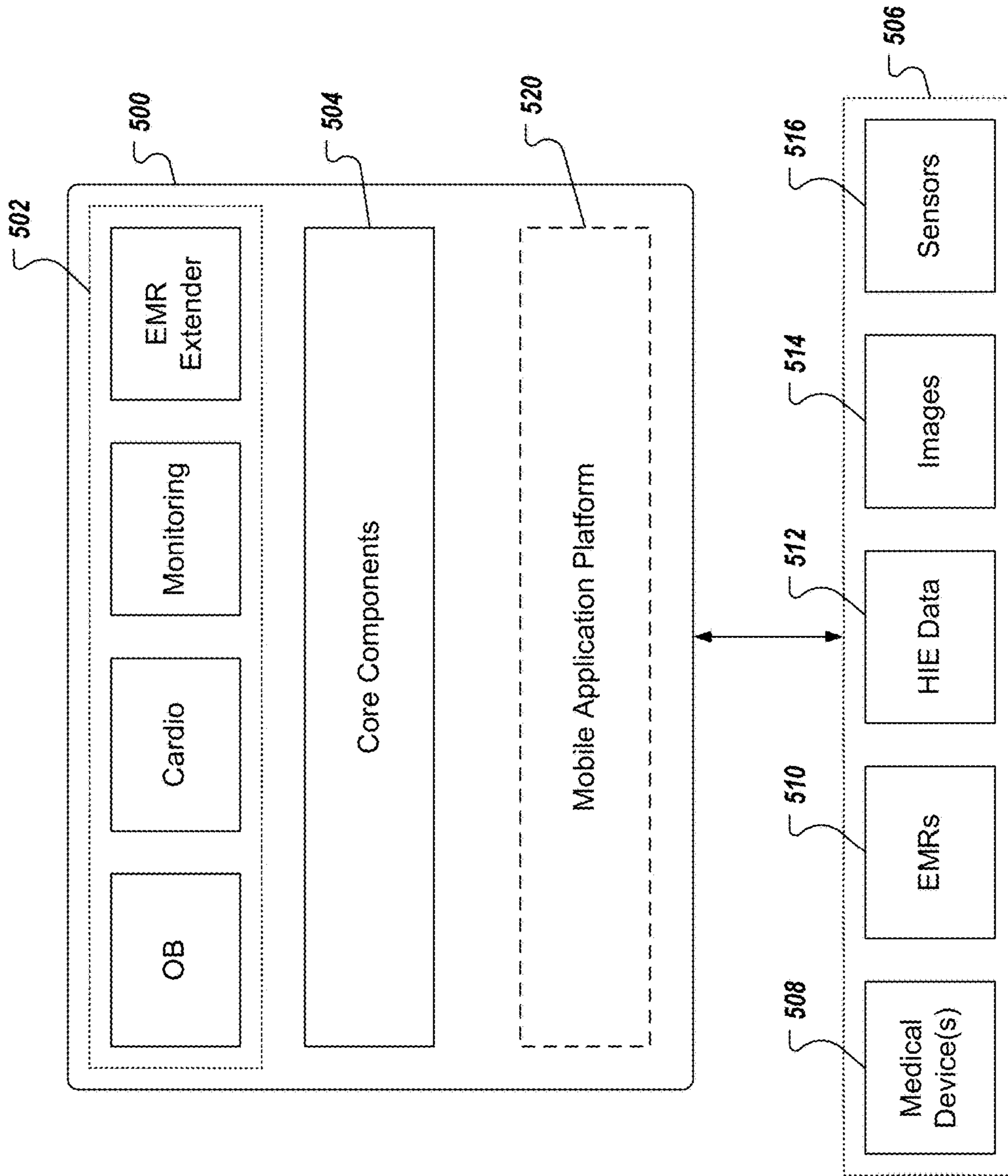

FIG. 5

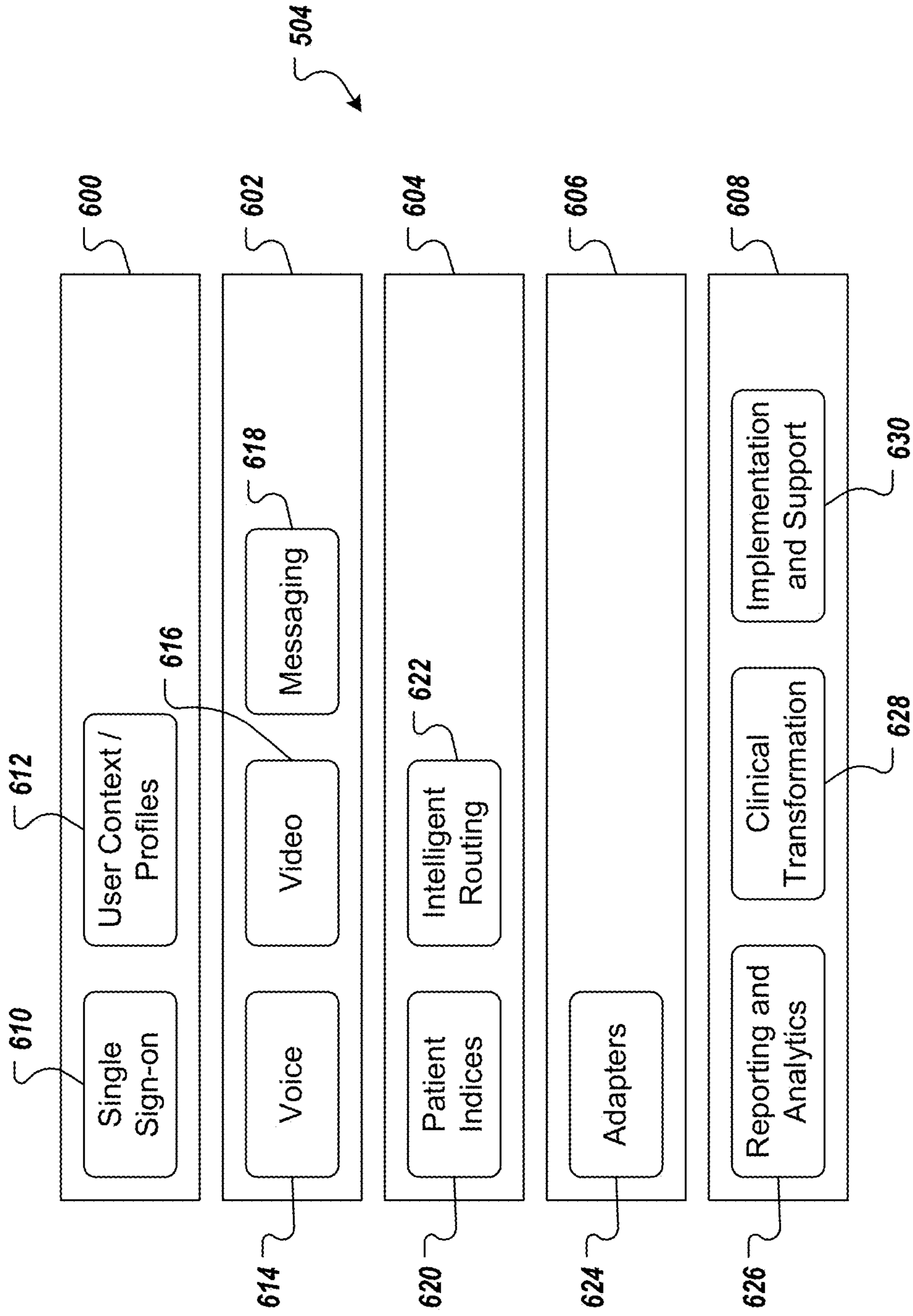

FIG. 6

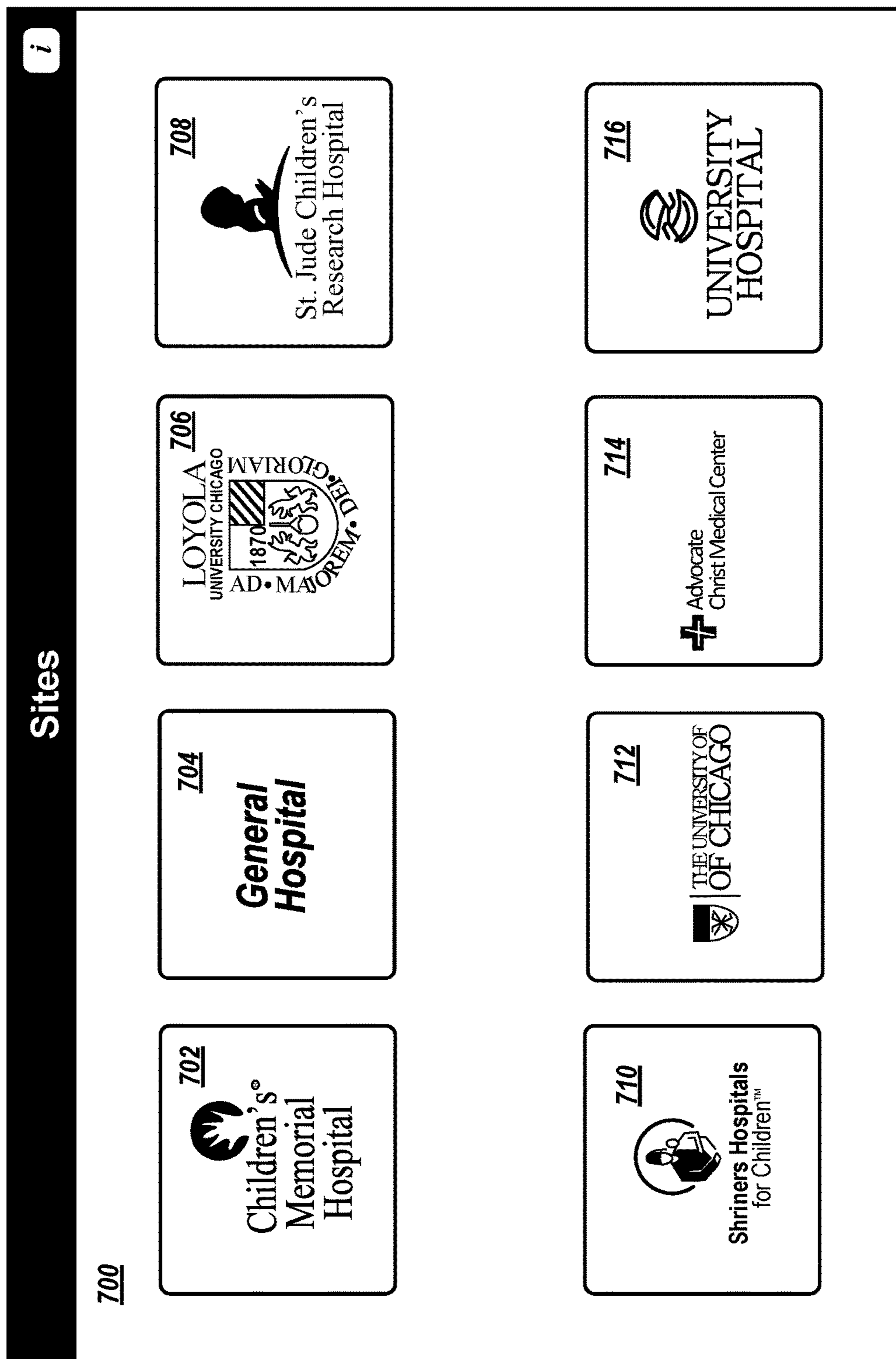

FIG. 7

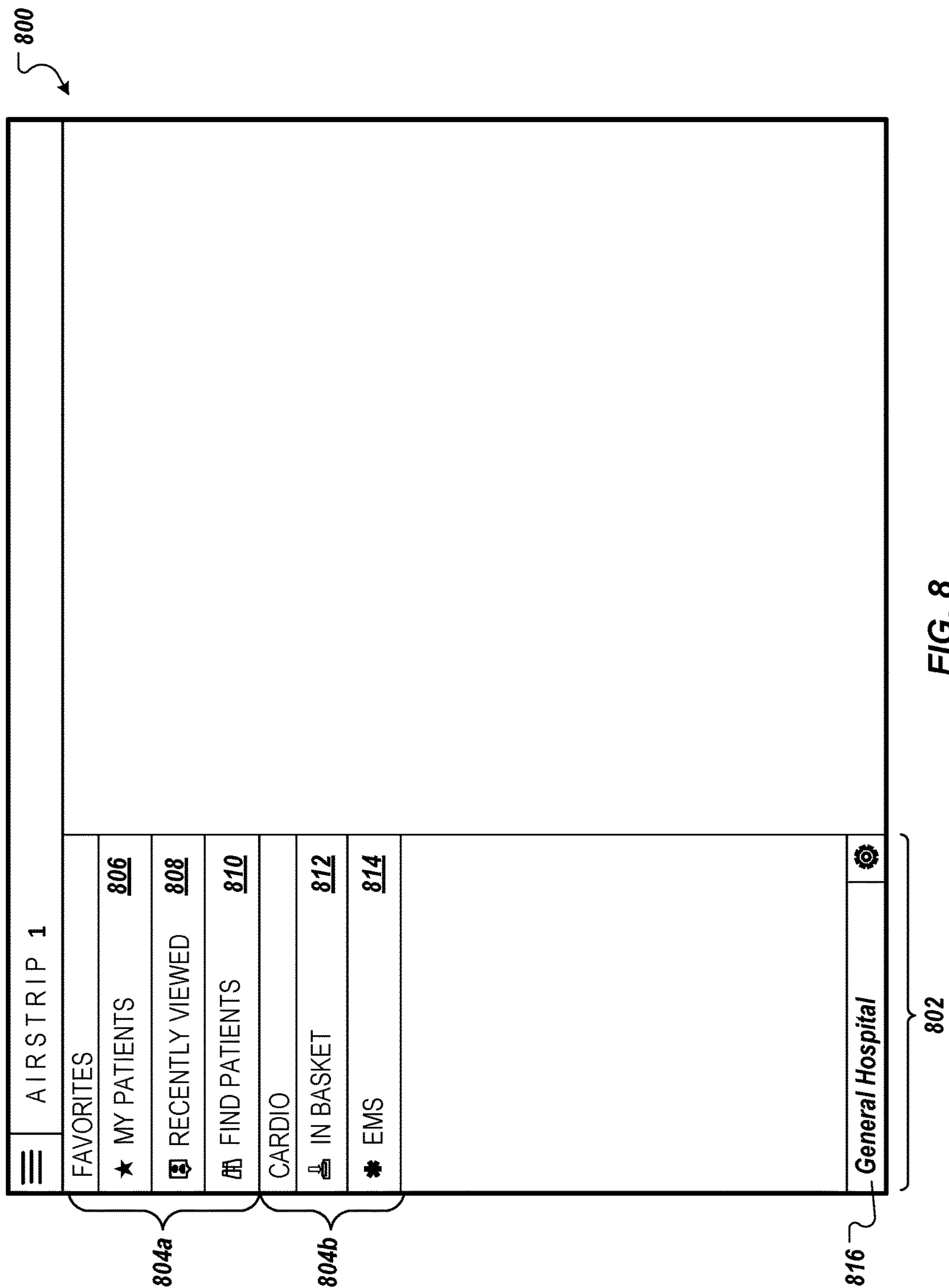

FIG. 8

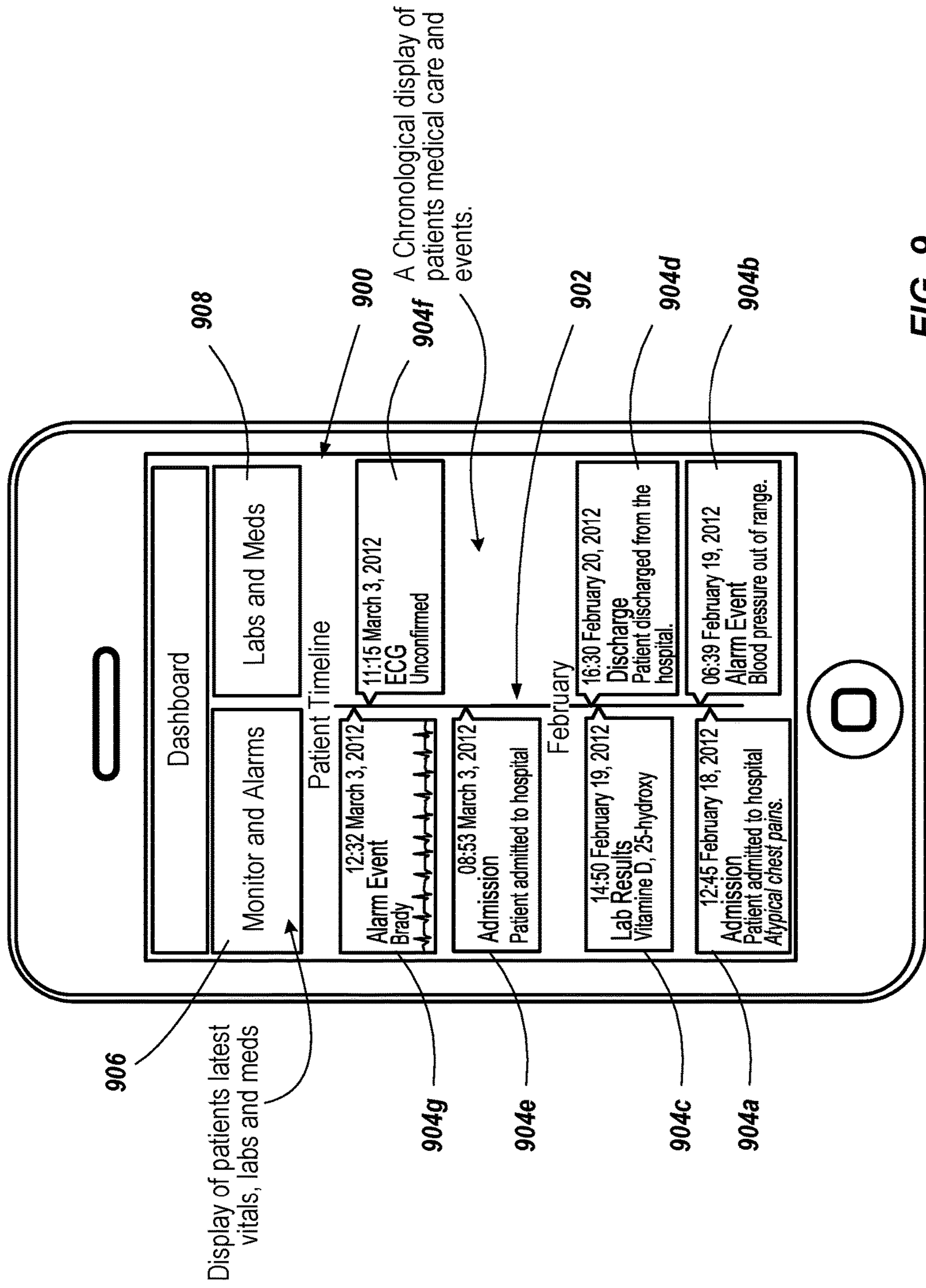

FIG. 9

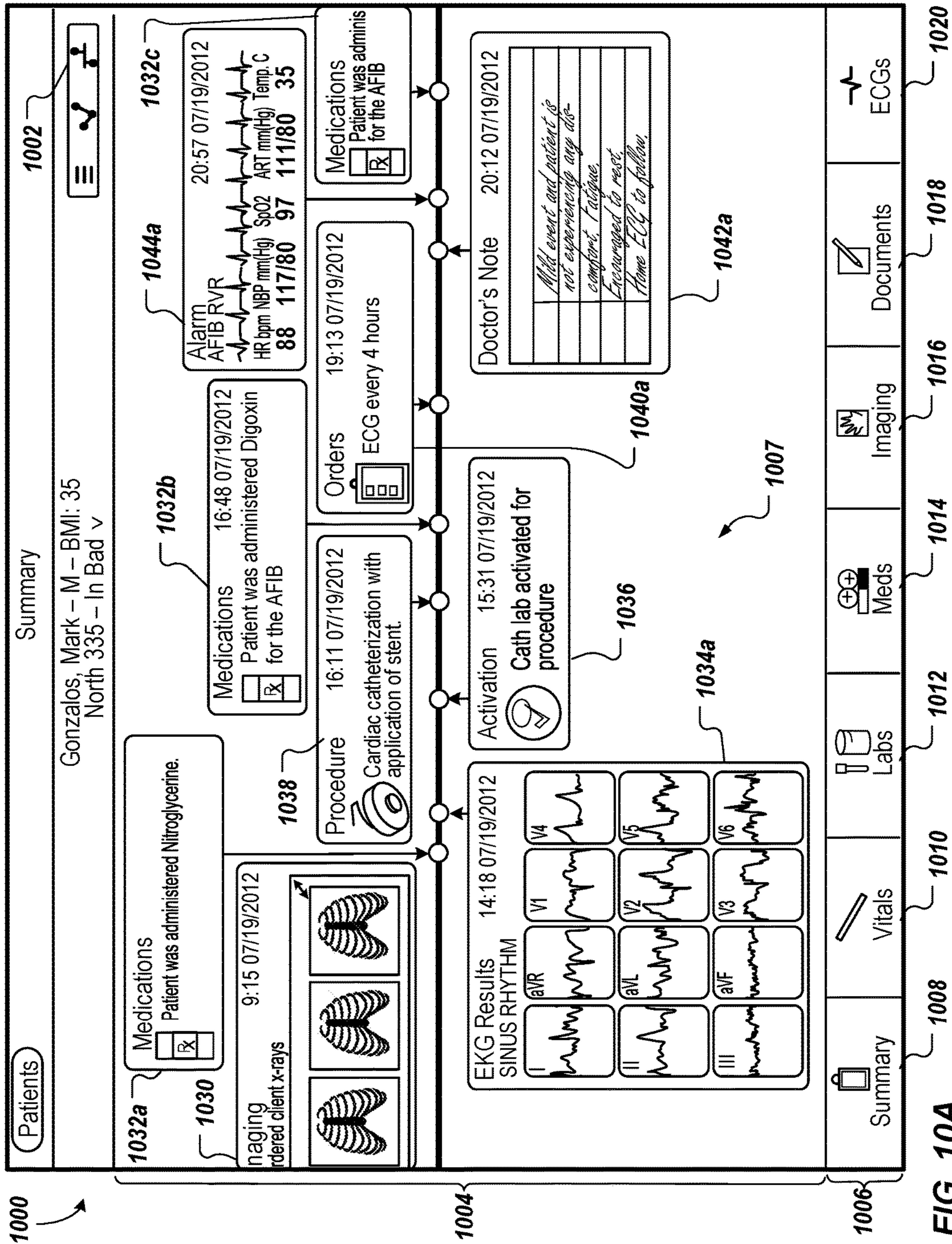

FIG. 10A

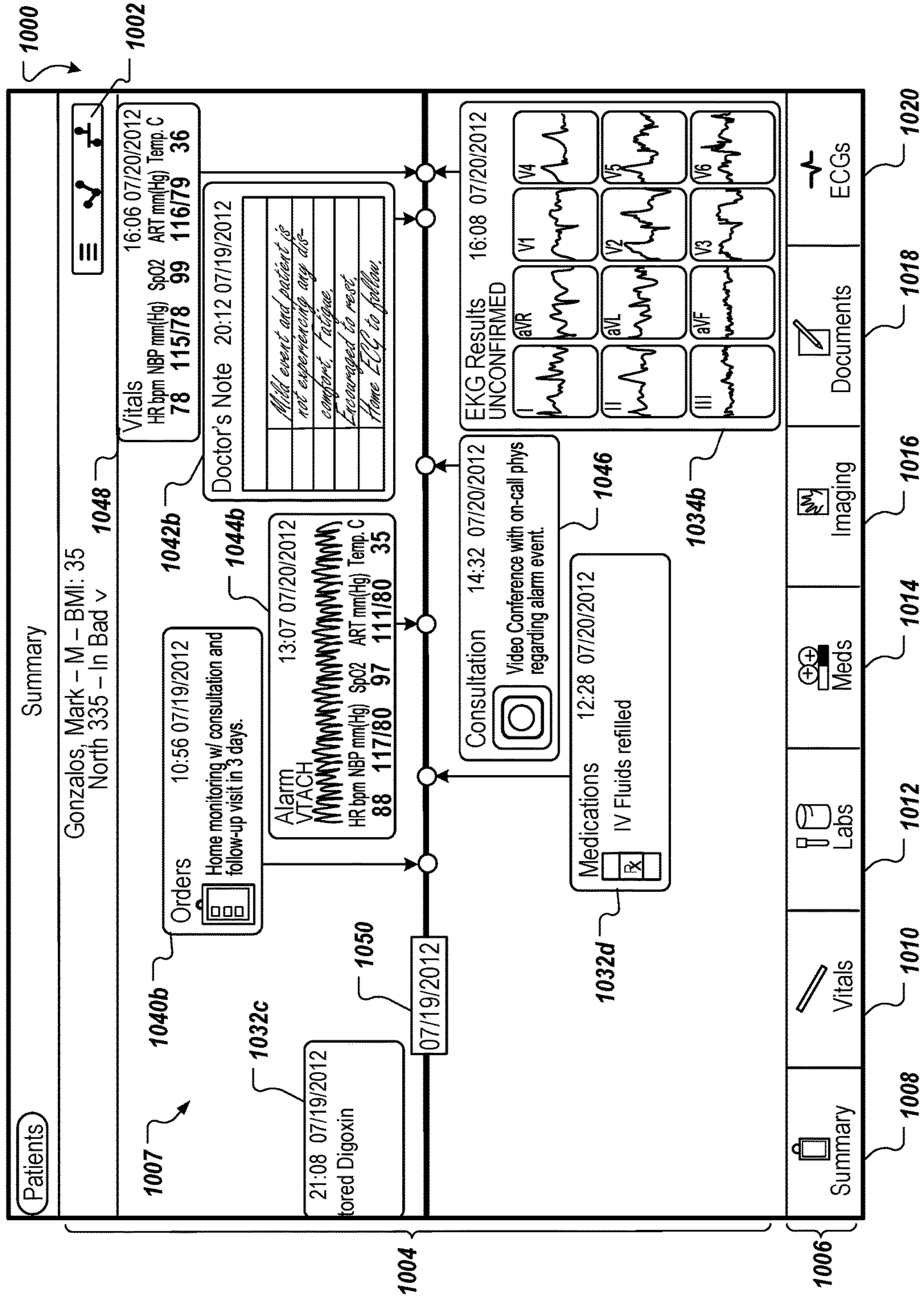

FIG. 10B

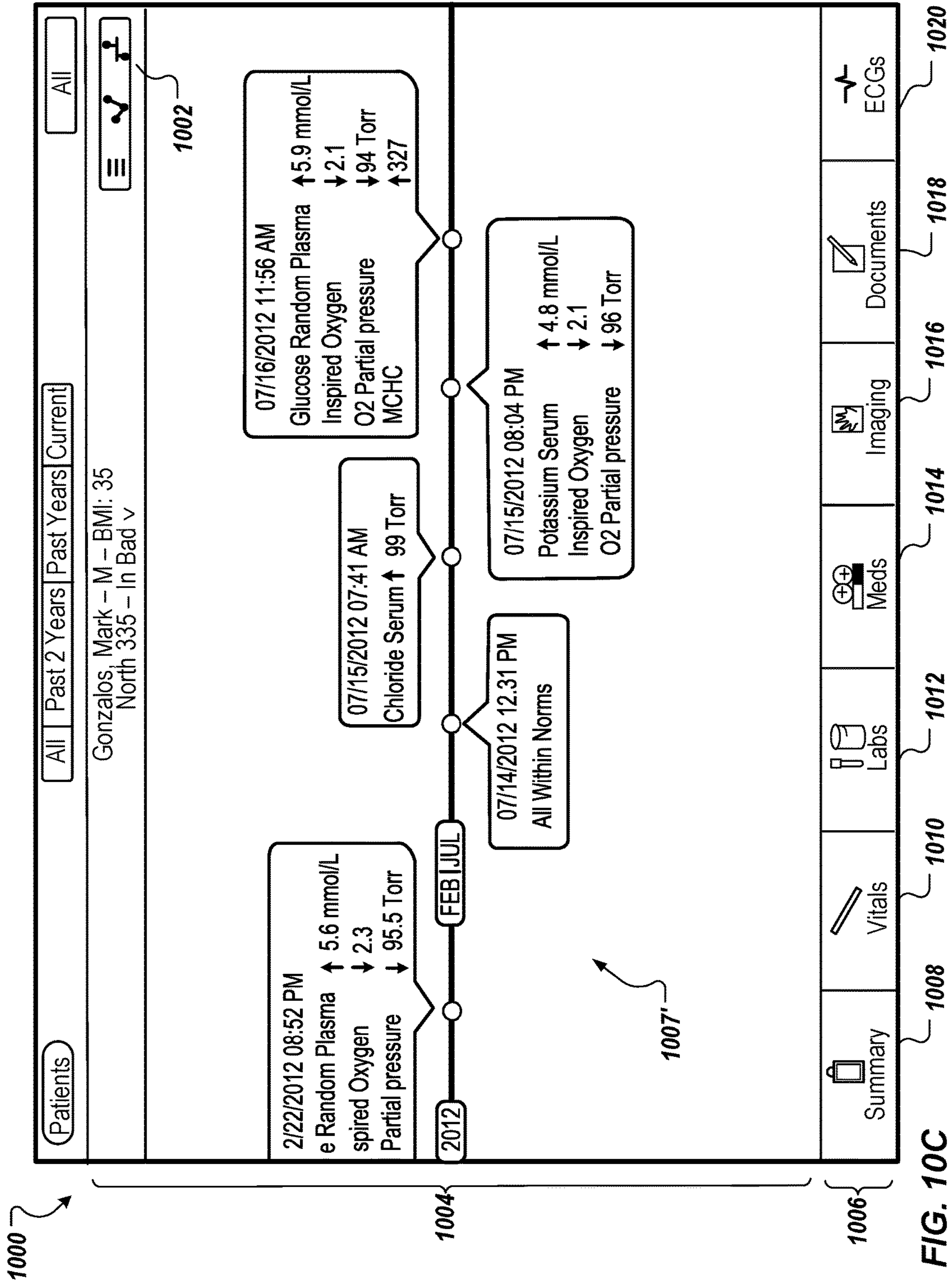

FIG. 10C

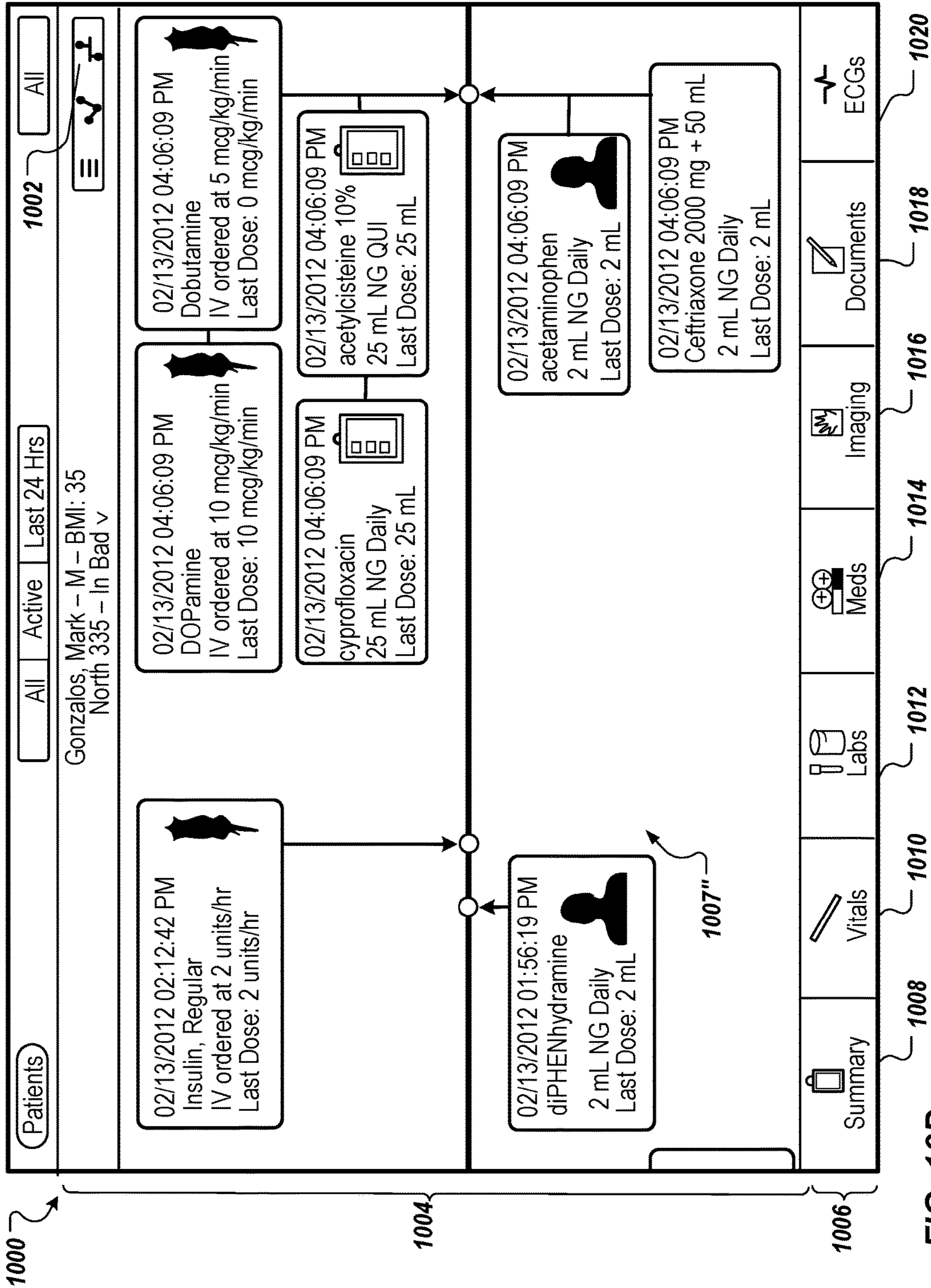

FIG. 10D

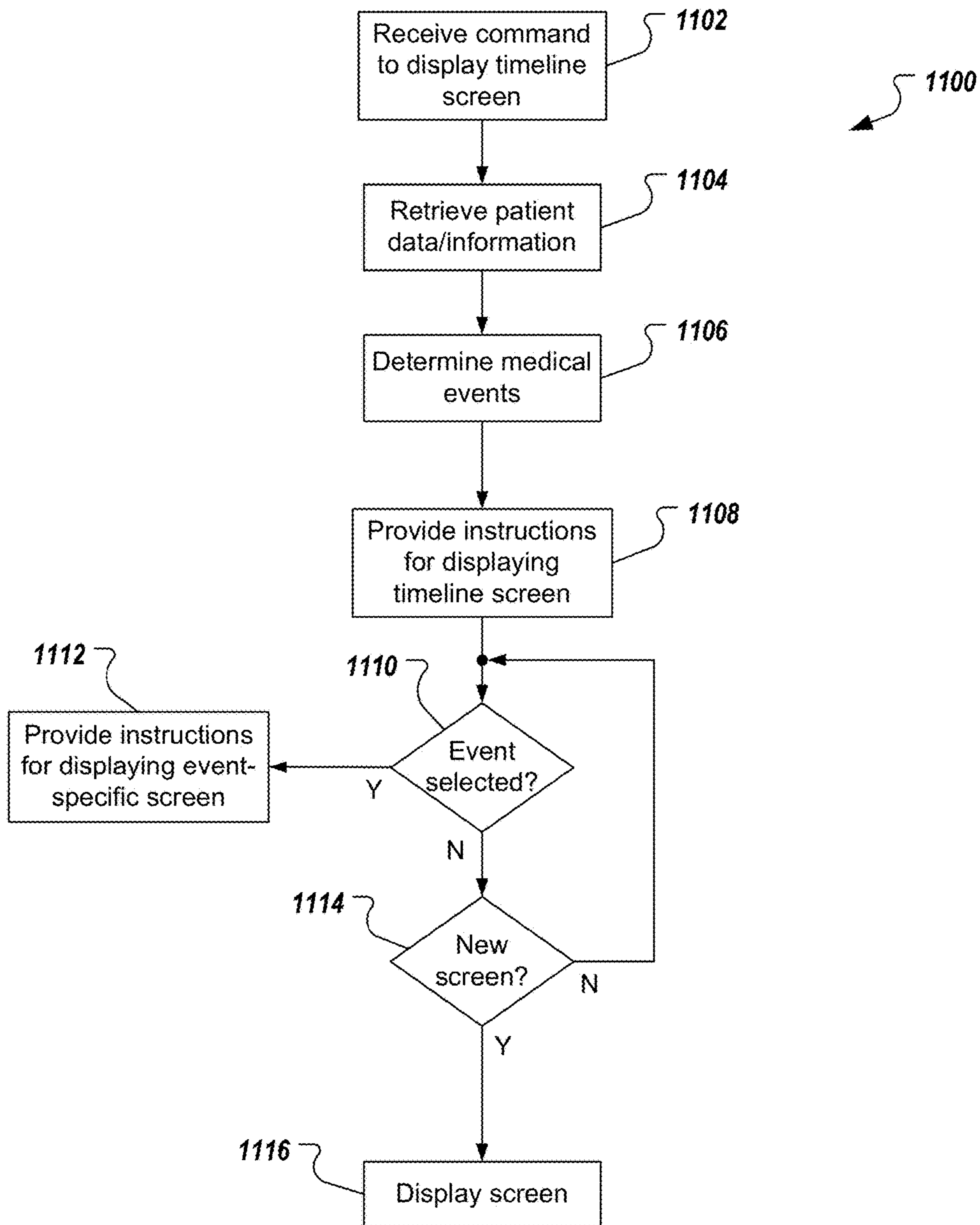

FIG. 11

SYSTEMS AND METHODS FOR AND DISPLAYING PATIENT DATA

CROSS-REFERENCE TO RELATED APPLICATION

This application claims the benefit and priority of U.S. Provisional Application Ser. No. 61/624,954, filed Apr. 16, 2012, the entire contents of which are expressly incorporated herein by reference in the entirety.

BACKGROUND

Implementations of the present disclosure are directed to displaying patient data and/or information on mobile devices.

While physicians and other health care providers currently utilize a large number of products and systems that benefit from advances in wireless communication technology, there are still significant limitations to the information that can be transmitted, received, and displayed over these devices in a practical and efficient manner. There are many limitations that are intrinsic to mobile devices, especially those constraints related to speed, performance, memory, and display size. In addition, because of the critical nature of medical data, it is important that the technology work reliably and efficiently over potentially low speed, low bandwidth, and sometimes intermittent wireless connections.

SUMMARY

Implementations of the present disclosure provide methods for providing a user of a mobile device access to patient information and patient physiological data. In some examples, methods include actions of receiving user input, the user input indicating a user command to display a timeline screen, in response to the user input, processing patient-specific data to determine one or more medical events to be graphically depicted, the one or more medical events being specific to a patient, and displaying the timeline screen on the mobile device, the timeline screen displaying a timeline associated with the patient and comprising at least a portion of the one or more medical events, each medical event comprising summary information, the one or more medical events being displayed in chronological order. Other implementations of this aspect include corresponding systems, apparatus, and computer programs, configured to perform the actions of the methods, encoded on computer storage devices.

These and other implementations can each optionally include one or more of the following features: each medical event corresponds to an event category of a plurality of event categories; actions further include receiving patient data and/or patient information from an electronic medical record (EMR) associated with the patient, the summary information including at least a portion of the patient data and/or patient information; actions further include determining the chronological order based on timestamp information associated with each of the one or more events; actions further include receiving user input associated with a medical event, and in response to the user input, displaying detailed medical event information; displaying detailed medical event information includes displaying an event screen in place of the timeline screen; actions further include receiving user input, and in response to the user input, scrolling the timeline in the timeline screen to display another portion of the one or more

medical events; actions further include receiving user input, and in response to the user input, zooming the timeline in the timeline screen to display another portion of the one or more medical events; at least one medical event of the one or more medical event includes an icon, the icon graphically depicting an event category associated with the at least one medical event; the icon includes a generic icon that is provided for all medical events of the same event category; the icon includes an event-specific icon that is specific to a sub-category associated with the at least one medical event; actions further include receiving user input specific to a medical event, and in response to the user input, manipulating summary information provided in the medical event; manipulating summary information provided in the medical event, includes scrolling the summary information provided in the medical event; the summary information provided in the medical event includes a waveform, and manipulating includes scrolling the waveform; the summary information provided in the medical event includes a plurality of thumbnail images, and manipulating includes scrolling between images of the plurality of thumbnail images; and actions further include receiving user input, the user input indicating user selection of a category icon, and in response to the user input, filtering the timeline to include a sub-set of the one or more medical events, medical events in the sub-set corresponding to a category associated with the category icon.

Other aspects of the present disclosure provide systems including one or more processors, and a computer-readable medium coupled to the one or more processors having instructions stored thereon which, when executed by the one or more processors, cause the one or more processors to perform one or more of the methods provided herein.

It is appreciated that methods in accordance with the present disclosure can include any combination of the aspects and features described herein. That is to say that methods in accordance with the present disclosure are not limited to the combinations of aspects and features specifically described herein, but also include any combination of the aspects and features provided.

The details of one or more implementations are set forth in the accompanying drawings and the description below. Other features, objects, and advantages will be apparent from the description and drawings, and from the claims.

DESCRIPTION OF DRAWINGS

FIG. 1 is a schematic illustration of an example system architecture in accordance with implementations of the present disclosure.

FIG. 2 is a schematic illustration of another example system architecture in accordance with implementations of the present disclosure.

FIG. 3 is a functional block diagram of an example system in accordance with implementations of the present disclosure.

FIG. 4 is a more detailed view of the functional block diagram of FIG. 3.

FIG. 5 depicts an example platform for providing integrated and unified views of patient data and patient information.

FIG. 6 depicts example components and sub-components that can be included in core components of FIG. 5.

FIGS. 7-10D depict example graphical user interfaces (GUIs) for providing integrated and unified views of patient data and patient information in accordance with implementations of the present disclosure.

FIG. 11 is a flowchart illustrating an example process that can be executed in accordance with implementations of the present disclosure.

Like reference symbols in the various drawings indicate like elements.

DETAILED DESCRIPTION

Implementations of the present disclosure are generally directed to an enterprise scalable, data- and vendor-agnostic mobility architecture to securely deliver patient data and information from medical devices, electronic medical records (EMRs) and patient monitors to healthcare providers anywhere across a healthcare continuum. More particularly, implementations of the present disclosure provide integrated and unified views of patient data and patient information on mobile devices (e.g., smartphones, tablets) from a plurality of data sources across the healthcare continuum. As discussed in further detail herein, implementations of the present disclosure enable timely and collaborative clinical decision-making, and enable healthcare systems to better track quality metrics, empower a mobile workforce, expand networks, and achieve clinical transformation.

Example systems and methods that can be included in implementations of the present disclosure are provided in U.S. Provisional Application Ser. No. 61/771,591, filed Mar. 1, 2013, the contents of which are expressly incorporated herein by reference in the entirety.

Referring now to FIG. 1, an example system architecture 100 is illustrated, and includes a mobile device 102, connectivity interface(s) 104, a network 106, a first facility system 108, and a second facility system 110. As discussed in further detail herein, data is transferred from each of the first and second facility systems 108, 110 through the network 106 and connectivity interface(s) 104 for presentation, or display on the mobile device 102. Further, data can be transferred from the mobile device 102 through the connectivity interface(s) 104 and the network 106 to each of the first and second facility systems 108, 110. Although a single mobile device 102 is illustrated, it is contemplated that one or more mobile devices 102 can communicate with each of the first and second facility systems 108, 110 through the network 106 and the connectivity interface(s) 104. Similarly, although two facility systems are illustrated, implementations of the present disclosure can include one or more facility systems.

The mobile device 102 can include any number of example devices. Such example devices include, but are not limited to, a mobile phone, a smartphone, a tablet computing device, a personal digital assistant (PDA), a laptop personal computer (PC), a desktop PC, and/or appropriate combinations thereof. In the depicted example, the mobile device 102 includes a display 122, a processor 124, memory 126, an input interface 128, and a communication interface 130. The processor 124 can process instructions for execution of implementations of the present disclosure. The instructions can include, but are not limited to, instructions stored in the memory 126 to display graphical information on the display 122. Example displays include, but are not limited to, a thin-film-transistor (TFT) liquid crystal display (LCD), or an organic light emitting diode (OLED) display. The memory 126 stores information within the mobile device 102. In some implementations, the memory 126 can include a volatile memory unit or units, and/or a non-volatile memory unit or units. In other implementations, removable memory can be provided, and can include, but is not limited to, a memory card. Example memory cards can include, but are

not limited to, a secure digital (SD) memory card, a mini-SD memory card, a USB stick, and the like.

In some examples, the input interface 128 can include a keyboard, a touchscreen, a mouse, a trackball, a microphone, a touchpad, and/or appropriate combinations thereof. In some implementations, an audio codec (not shown) can be provided, which receives audible input from a user or other source through a microphone, and converts the audible input to usable digital information. The audio codec can generate audible sound, such as through a speaker that is provided with the mobile device 102. Example sounds can include sound from voice telephone calls, recorded sound (e.g., voice messages, music files, etc.), and/or sound generated by applications operating on the mobile device 102.

The mobile device 102 may communicate wirelessly through the communication interface(s) 104, which can include digital signal processing circuitry. The communication interface(s) 104 may provide communications under various modes or protocols including, but not limited to, GSM voice calls, SMS, EMS or MMS messaging, CDMA, TDMA, PDC, WCDMA, CDMA2000, and/or GPRS. Such communication may occur, for example, through a radio-frequency transceiver (not shown). Further, the mobile device can be capable of short-range communication using features including, but not limited to, Bluetooth and/or WiFi transceivers (not shown).

The mobile device 102 communicates with the network 106 through the connectivity interface(s) 104. In some examples, the connectivity interface(s) 104 can include a satellite receiver, cellular network, a Bluetooth system, a Wi-Fi system (e.g., 802.x), a cable modem, a DSL/dial-up interface, a private branch exchange (PBX) system, and/or appropriate combinations thereof. Each of these connectivity interfaces 104 enables data to be transmitted to/from the network 106. In some examples, the network 106 can be provided as a local area network (LAN), a wide area network (WAN), a wireless LAN (WLAN), a metropolitan area network (MAN), a personal area network (PAN), the Internet, and/or combinations thereof.

In the example systems of FIGS. 1 and 2, the first facility system 108 includes a plurality of facilities 140, and the second facility system 110 includes a facility 140. It is contemplated that each facility system 108, 110 can include one or more facilities, and is not limited to the example arrangement described herein. In the case of multiple facilities, the facilities can be remotely located from one another, and/or can be located at a common location, or site (e.g., separate departments in a common (the same) building). Each facility system 108, 110 can be provided as a medical care system, for example, which medical care system can include one or more hospitals, hospital systems, clinics, physician offices, and the like.

In some examples, each facility 140 includes an associated information system 142, computer interface(s) 144, and patient monitoring device(s) 146. Example information systems can include, but are not limited to, a clinical information system (CIS), an EMR system, an electronic health record (EHR) system, and/or a hospital information system (HIS). Each information system 142 can be provided as a server, and supports the acquisition, storage, modification, and distribution of clinical information, such as patient data, throughout the facility 140 and/or facility system 108, 110. In some examples, each information system 142 can communicate with one or more ancillary information systems (not shown) that can include, but are not limited to, a pharmacy management system, a laboratory management system, and/or a radiology management system. Although

the example system architecture **100** includes an information system **142** located at each facility **140**, it is contemplated that the facilities **140** can communicate with a common information system **142** that is remotely located from either facility **140**, or that is located at one of the facilities **140** within the facility system **108**, **110**.

In some examples, the computer interface **144** can communicate with the information system **142** to enable access to information that is stored within, and managed by the information system **142**. In some examples, the computer interface **144** can include a personal computer (PC) (e.g., desktop, laptop, or tablet). Although a single computer interface **144** is illustrated in the example architectures described herein, it is contemplated that one or more computer interfaces **144** can communicate with the information system **142**. Communication between each computer interface **144** and the information system **142** can be achieved via a direct connection, or remotely through a network (not shown) that can include, but is not limited to, a LAN, a WAN, a WLAN, and/or the Internet.

In some examples, each patient monitoring device **146** monitors physiological characteristics of a particular patient **150**, and generates data signals based thereon. As discussed in further detail herein, implementations of the present disclosure provide patient monitoring devices that include a computing device, such as a tablet computing device. The data signals are communicated to the information system **142**, which collects patient data based thereon, and stores the data to a patient record that is associated with the particular patient. An example patient record can include an electronic medical record (EMR). Although a single patient monitoring device **146** is illustrated per each patient **150**, it is contemplated that multiple patient monitoring devices **146** can monitor a particular patient **150**. The patient monitoring device(s) **146** can communicate with the information system **142** via a direct connection, or remotely through a network (not shown) that can include, for example, a LAN, a WAN, a WLAN, and/or the Internet.

In some examples, the patient data is made available for display on the computer device **144**. A healthcare provider (e.g., a nurse and/or physician) can augment the patient data by inputting patient information that is also stored to the information system **144**. More specifically, the healthcare provider can input patient information corresponding to a particular patient **150**, which patient information can be stored to the patient record (e.g., EMR). As one example, a nurse can input nursing notes, which nursing notes can be stored to the patient record in the information system. Example patient information can include any non-physiological information corresponding to a patient (e.g., name, age, date-of-birth (DOB), gender).

As discussed above, each information system **142** stores patient data that can be collected from the patient monitoring devices **146**, as well as additional patient information, that can include information that is input by a healthcare provider. The information system **144** communicates the patient data and/or the additional patient data to a data management system (DMS) **160**. The DMS **160** can be provided as a server, or a virtual server, that runs server software components, and can include data storage including, for example, a database and/or flat files. In the example system architecture **100** of FIG. 1, each facility system **108**, **110** includes a corresponding DMS **160**. In such an arrangement, each information system **142** communicates patient data, and/or additional patient data to the DMS **160**. Furthermore, and as discussed in further detail below, the DMS **160** can communicate ancillary information to the information system

142. Communication between the DMS **160** and the information system(s) **142** can be achieved via a direct connection, or remotely through a network (not shown) that can include, for example, a LAN, a WAN, a WLAN, and/or the Internet.

In some examples, a DMS **160** corresponding to a particular facility system can be remotely located from any of the facilities **140** of the facility system **108**, **110**, or can be located at a particular facility **140** of the facility system **108**, **110**. In the example system architecture **100** of FIG. 1, the DMS **160** is remotely located from either facility **140** within each of the facility systems **108**, **110**. It is contemplated, however, that the DMS **160** can be located at one of the facilities **140**, and remote from the other facility **140**.

In the example system architecture **100'** of FIG. 2, a DMS **160'** is provided that is common to (the same for) the facility systems **108**, **110**. For example, the DMS **160'** can be described as being common to various facility systems **108**, **110**, and is not associated with a particular facility system **108**, **110**. For example, the DMS **160'** can be hosted by a third-party vendor (e.g., a cloud service provider). In some examples, each information system **42** communicates with the DMS **160'** via a direct connection, or remotely through a network (not shown) that can include, but is not limited to, a LAN, a WAN, a WLAN, and/or the Internet. In the example arrangement of FIG. 2, the DMS **160'** communicates with each of the information systems **142** through the network **106**. The information systems **142** communicate patient data and/or patient information to the DMS **160'**, and the DMS **160'** can communicate ancillary information to the information system **142**, as discussed in further detail below.

In the example system architecture **100** of FIG. 1, the facility **140**, or facility system **108**, **110** installs the DMS **160** as a local DMS, and the DMS **160** sits at the local site with other servers that can include, for example, the information system **142**. In some implementations, the DMS **160** can be sectioned off, or separated from a logical network perspective, but still physically exists with the other servers that belong to the respective facility **140**. In some examples, server components are installed on the DMS **160**, which components can include, for example, a database component, a database synchronization component, a web services component, and/or a structured query language (SQL) component. An information system interface can also be installed on the DMS **160**, and functions as the interface to the information system **142**. As one example, the information system interface can include OBLink, provided by GE Healthcare. In some implementations, the DMS **160** can be arranged in a multiple server configuration, in which one server only hosts web service related components and is logically segregated, and another server has the remaining necessary server components installed.

The example system architecture **100'** of FIG. 2, provides for the remote location of data collection at the DMS **160'**. In such implementations, the DMS **160'** can be provided at a third-party site, remote from any of the facilities **140**, or facility systems **108**, **110**. The third-party functions as a DMS host, and the necessary server components are installed on the remotely hosted DMS **160'**. In some implementations, a business-to-business (B2B) virtual private network (VPN) can be created between the remotely hosted DMS **160'** and the network of the facility **140** or facility system **108**, **110**. In this manner, the facility **140** and/or facility system **108**, **110** forgoes the purchase and/or maintenance of another physical server, or DMS **160**. Further, the up-time and the status of availability of the DMS **160'** are easier to manage on the part of a dedicated third-party. The

DMS' access to the network can be attended to by the third-party, as opposed to burdening the facility 140, or the facility systems 108, 110. Further, the third-party can implement virtual server technologies to leverage multiple DMS installations on a single physical server. In such implemen-

5 tations, a plurality of virtual servers are logically partitioned in a single physical server, and each virtual server has the capability of running its own operating system and server components, and can be independently booted. In accordance with implementations of the present disclosure, the DMS 160, 160' synchronizes and transfers data between the mobile device 102, or multiple mobile devices 102, and the information system 142, or multiple information systems 142. More specifically, the DMS 160, 160' processes and prepares the patient data and/or patient information for transfer to and presentation on the mobile device 102, or multiple mobile devices 102, from the information system 142, and/or other systems, as discussed in further detail herein. The DMS 160, 160' also processes and prepares ancillary information for transfer to and storage in the information system 142 from the mobile device 102, or multiple mobile devices 102 for potential presentation at a corresponding computer device 144. Example DMSs can include, but are not limited to, the AirStrip Server provided by AirStrip Technologies, LLC, which AirStrip Server includes AirStrip Server Components installed therein.

Referring now to FIGS. 3 and 4, example module structure, or system 300 that can be implemented to provide features of the present disclosure will be described in detail. In some examples, the example system 300 enables patient data and patient information to be communicated to/from, and to be exchanged between mobile devices and data sources across healthcare continua. In some examples, each module can be provided as one or more computer-executable programs that are executed using one or more computing devices (e.g., computing devices provided as part of a DMS, computing devices located at one or more facilities of a facility system).

FIG. 3 illustrates an overview of the example system 300. In the depicted example, the module structure includes modules located at a DMS 301, a first facility system 302 and a second facility system 304. In some examples, the first facility system 302 and the second facility 304 can be included in at least a portion of a healthcare continuum, discussed in further detail herein. The facility system 302 includes a patient record module 303 (e.g., EMR module) that accesses one or more patient records managed and stored by the facility system 302. The facility system 304 includes a patient record module 305 (e.g., EMR module) that accesses one or more patient records managed and stored by the facility system 304.

In the depicted example, and as discussed in further detail herein, patient data and/or information can be provided for integrated and unified display on the mobile device 102 through the network 106 and the DMS 301 from across healthcare continua (e.g., the facility systems 302, 304). In some examples, patient data and/or information can be provided for display on a mobile device 102', 102" through the network 106 from a facility system (e.g., the facility system 302, 304). In some examples, the mobile devices 102, 102', 102" are the same device. That is, for example, a mobile device can receive patient data and/or information from across a healthcare continuum, and/or from individual facility systems.

In some implementations, the DMS 301 includes a web module 310, a host module 312, a data cache module 314 and an adapter module 316, web module 320, a host module

322, a data cache module 324, a collector module 326. In general, modules of the DMS 301 enable the DMS 301 to retrieve and combine data from multiple facility systems (e.g., the facility systems 302, 304) across healthcare continua. In some examples, the web module 310 provides a first-level network facing interface to the DMS infrastructure. In some examples, and in response to a request from a mobile device (e.g., the mobile device 102), the web module 310 performs request validation and user authentication and routes the request to the host module 312. In some examples, the web module 310 includes one or more sub-modules. Example sub-modules include a request validation sub-module, which validates received requests, a user authentication module, which authenticates an identity of the user and/or mobile device from which a request is received, and a request routing sub-module, which routes requests after validation and authentication.

In some implementations, the host module 312 orchestrates request processing. In some examples, the host module 312 includes one or more sub-modules. Example sub-modules include a request parsing sub-module that parses received requests, a pipeline assembly sub-module, a pipeline processing sub-module, an operation execution sub-module, a data access sub-module, a results formatting sub-module, an access control sub-module, an encryption sub-module, a data conditioning sub-module, and a logging sub-module. In some examples, the host module 312 parses a received request (e.g., using the request parsing sub-module) to determine, for example, what type of device issued the request, which application executing on the device issued the request, and/or patient data/information (or other data such as analytical data, discussed below) is needed to fulfill the request. In some examples, and based on the parsed information, the host module 312 builds a pipeline (e.g., using the pipeline assembly sub-module). In some examples, a pipeline can be provided as a list of tasks that need to be executed to fulfill the request. Example tasks can include retrieving particular patient data/information, processing retrieved patient data to generate additional data and/or data visualizations (e.g., analytical data, trend graphs, discussed below), encrypting/decrypting retrieved data, performing access control to retrieve data, generating logs of tasks.

In some implementations, the host module 312 coordinates data retrieval with the data cache module 314 (e.g., using the data access sub-module). The retrieved data is provided back to the host module 312. In some examples, the host module 312 processes the retrieved data (e.g., using the operation execution sub-module, the results formatting sub-module and/or the data conditioning sub-module). In some examples, the retrieved data is processed to generate additional data (e.g., data used for data visualizations). In some examples, the retrieved data and/or the additional data are conditioned to provide efficient transfer back to the requesting mobile device. In some examples, conditioning can include converting data based on transmission protocol, formatting data for optimal display on the particular device, and/or packaging data to send to the requesting device.

In some implementations, the data cache module 314 enables access to and optional storage of detailed patient data/information used by other components of the system 300. In some examples, the data cache module 314 includes one or more sub-modules and/or data stores. An example sub-module can include a cache services sub-module. In some examples, the data cache module 314 can operate in a pass-through mode (real-time mode) and a reposed mode. In some examples, patient data/information required to satisfy

a given request can be directly accessed from a source system (e.g., the facility system **302**, **304**) in real-time. In such examples, the data cache module **314** operates in a pass-through mode, retrieving the patient data/information from multiple data sources and passing the patient data/information onward for responding to the request. In some examples, an application program interface (API), or other programmatic mechanism can be used to retrieve the patient data/information. In some examples, in the pass-through mode, patient data/information is not stored in a persistent data store accessed by the data cache module **314**. In some implementations, it might be desired to improve retrieval performance. Consequently, the data cache module **314** can store data identifiers and/or pointers in a persistent data store. When in the pass-through mode, the data cache module **314** uses the adapter module **316** to perform the actual retrieval of patient data/information from one or more facility systems.

In some examples, the patient data/information that is required to satisfy a request cannot be directly accessed from the facility systems (e.g., the facility systems **302**, **304**). In such examples, the data cache module **314** operates in the reposed mode. In some examples, in the reposed mode, the data cache module **314** stores a detailed copy of the patient data/information in the persistent data store. That is, for example, stored patient data/information is stored at the DMS-level, but had been retrieved from remote data sources (e.g., data sources located at the facility systems **302**, **304**). In some examples, when a request is made for patient data/information in the reposed mode, the patient data/information is retrieved directly from the persistent data store (e.g., by the cache services sub-module).

In some implementations, the adapter module **316** enables the retrieval of patient data/information from across health-care continua. Consequently, the adapter module **316** can be referred to as a federated adapter module. In some examples, in response to receiving a request from the mobile device **102** for patient data/information from multiple data sources (e.g., the facility systems **302**, **304**), the data cache module **314** utilizes the adapter module **316** to retrieve the requested patient data/information from the multiple data sources. In some examples, the adapter module **316** communicates with local host modules (discussed in further detail below) of the respective facility systems.

In some implementations, the request processing operation of the DMS **301** is stateless. More particularly, the modules of the DMS **301** handle each received request as a distinct unit and, once a request is handled, stores no state information associated with a completed request. In other words, after the DMS **301** has processed a request, the DMS **301** (e.g., modules within the DMS **302** that handled the request) “forget” that the request even occurred. In this manner, subsequently received requests are not influenced by (e.g., handled based on) previously processed requests.

In some examples, operation of the DMS **301** is stateless, but the DMS **301** can still provide a log of requests handled (e.g., using the logging sub-module). For example, a request log can be accessed during an audit of the system **300**.

In some implementations, each facility system **302**, **304** includes one or more local web modules **320**, **330**, one or more local host modules **322**, **332**, one or more local data cache modules **324**, **334**, and one or more vocabulary service modules **328**, **338**. In the depicted example, the facility system **302** includes one or more collector modules **326**, and the facility system **304** includes one or more patient record (EMR) adapter modules **336**.

In some examples, each of the web modules **320**, **330** provides functionality as similarly discussed above with respect to the web module **310**. More particularly, the web modules **320**, **330** operate at a local level (e.g., local to the respective facility systems **302**, **304**), each performing request validation and user authentication, and routing requests to the respective local host modules **322**, **332**. For example, the web modules **320**, **330** can receive requests from the respective mobile devices **102'**, **102''**, can validate the requests and authenticate the respective users/mobile devices, and route the requests accordingly. In some examples, each web module **320**, **330** includes one or more sub-modules. Example sub-modules include a request validation sub-module, which validates received requests, a user authentication module, which authenticates an identity of the user and/or mobile device from which a request is received, and a request routing sub-module, which routes requests after validation and authentication.

In some examples, each of the local host modules **322**, **332** provides functionality as similarly discussed above with respect to the host module **312**. More particularly, the local host modules **322**, **332** operate at a local level (e.g., local to the respective facility systems **302**, **304**), each orchestrating request processing. In some examples, the local host modules **322**, **332** orchestrate request processing for requests received from the mobile device **102** through the DMS **301**, and/or from the respective mobile devices **102'**, **102''** through the respective local web modules **320**, **330**. In some examples, each local host module **322**, **332** includes one or more sub-modules. Example sub-modules include a request parsing sub-module that parses received requests, a pipeline assembly sub-module, a pipeline processing sub-module, an operation execution sub-module, a data access sub-module, an access control sub-module and an encryption sub-module.

In some examples, each of the local data cache modules **324**, **334** provides functionality as similarly discussed above with respect to the data cache module **314**. More particularly, the local data cache modules **324**, **334** operate at a local level (e.g., local to the respective facility systems **302**, **304**), each enabling access to and optional storage of detailed patient data/information used by other components of the system **300**. In some examples, the each data cache module **324**, **334** can operate in a pass-through mode and a reposed mode, as discussed above with respect to the data cache module **314**. In the pass-through mode, the local data cache modules **324**, **334** retrieve the patient data/information from one or more local data sources and passed the patient data/information onward for responding to the request. In some examples, it might be desired to improve retrieval performance. Consequently, the local data cache modules **324**, **334** can store data identifiers and/or pointers in a persistent data store. When in the pass-through mode, the local data cache modules **324**, **334** use the collector module **326** and the patient record adapter module **336**, respectively,

to perform the actual retrieval of patient data/information from local data source(s) (e.g., the patient record module **303** and the patient record module **305**, respectively). In some examples, when in the pass-through mode, the local data cache modules **324**, **334** can write data back to the respective patient record modules **303**, **305**.

In some examples, the patient data/information that is required to satisfy a request (e.g., from the mobile device **102'**, **102''**) cannot be directly accessed from the local data sources (e.g., the patient record modules **303**, **305**). In such examples, each local data cache module **324**, **334** can operate in the reposed mode. In some examples, in the

reposed mode, the local data cache module **324**, **334** stores a detailed copy of the patient data/information in the persistent data store. That is, for example, stored patient data/information is stored at the local level, having been previously received from local data source(s) (e.g., the patient record modules **303**, **305**). In some examples, when a request is made for patient data/information in the reposed mode, the patient data/information is retrieved directly from the persistent data store (e.g., by the cache services sub-module).

In some implementations, the collector module **326** and the adapter module **336** are specific to the type of patient record module **303**, **305**, respectively. In the example of FIG. **3**, the patient record module **303** can be accessed based on a particular messaging protocol. An example messaging protocol can include the Health Level 7 (HL7) messaging protocol. In some examples, patient data/information provided based on such messaging protocols is reposed by the data cache module **324**. Consequently, requests for such data can be fulfilled based on operation of the data cache module **314** and/or the local data cache module **324** in the reposed mode, as discussed above. In some examples, changes to patient records in the patient record module **303** can trigger updating of reposed patient data/information by the data cache modules **314**, **324**. For example, the collector module **326** can automatically receive a message from the patient record module **303** in response to a change/updated, triggering updating/changing of reposed patient data/information.

In the example of FIG. **3**, the patient record module **305** supports programmatic interface (e.g., API) access. In some examples, patient data/information provided through programmatic interfaces is passed-through the data cache module **314** and/or the data cache module **334**. Consequently, requests for such data can be fulfilled based on operation of the data cache module **314** and/or the local data cache module **334** in the pass-through mode, as discussed above. In this manner, such patient data/information is not persisted by the data cache module **314**, **334**.

Although the example of FIG. **3** depicts facility systems **302**, **304** having different types of patient record modules **303**, **305**, it is appreciated that facility systems can include any appropriate combination of types of patient record modules and any number of patient record modules (e.g., patient record modules **303**, **305**), and respective adapter modules (e.g., modules **326**, **336**). Further, although the example of FIG. **3** depicts two facility systems, implementations of the present disclosure are applicable in instances include any number of facility systems.

In some implementations, the vocabulary services modules **328**, **338** perform translation between the vendor-specific vocabularies and a standard vocabulary. In this manner, patient data/information retrieved through the modules **303**, **305** use standard vocabulary to be provided back to the mobile device **102** in a unified manner. For example, the patient record modules **303**, **305** can each be provided by a respective third-party (e.g., a vendor) and can record data/information based on a vocabulary that is specific to the particular vendor. Consequently, data sources provided from different third-parties can refer to the same data/information or type of data/information using different terminology. In some examples, each vocabulary service module **328**, **338** is specific to a respective patient record module **303**, **305**.

FIG. **4** is a more detailed view of the functional block diagram of FIG. **3**, depicting additional components of the example system **300**. In the depicted example, the DMS **301** further includes a patient list import module **400**, a patient

membership portal module **402**, a patient matching service module **404**, a provider management (mgmt) module **406**, a patient information data store **408**, and a directory information data store **410**. In some examples, the patient information data store **408** stores patient demographic information **420**, a data pointer cache **422**, a patient-to-provider index **424** and a patient-to-facility index **426**. In some examples, the directory information data store **410** stores a facility directory **430**, a provider directory **432**, and provider-to-facility index **434**.

In some implementations, the patient list import module **400** enables initial and ongoing import of patient lists and patient demographic information for patients. In some examples, the patient list import module **400** provides an interface to receive a patient list, e.g., provided in a computer-readable document, and processes the patient list to populate the patient information data store **408** (e.g., the demographic information **420**). In some examples, the patient membership portal module **402** provides an interface that enables users (e.g., an administrator) to establish relationships between patient data/information stored across healthcare continua and particular patients. In some examples, healthcare providers, facilities and/or facility systems across healthcare continua can be included in a healthcare organization (e.g., an accountable care organization (ACO)). In some examples, the patient membership portal module **402** enables a user to define relationships between multiple patient records (e.g., based on respective medical record numbers (MRNs)) to the healthcare organization. In some examples, relationship information defined through the patient membership portal module **402** can be stored in the patient information data store **408**.

In some implementations, the patient matching service module **404** can be accessed by the host module **312** and the patient membership portal module **402**. In some examples, the patient matching service module **404** can be accessed by an application executed on a mobile device (e.g., the mobile device **102**) through the host module **312**. In some examples, the patient matching service module **404** processes patient data and/or patient information to identify potential patient matches between disparate data sources (e.g., multiple, different EMRs across the healthcare continuum). In some examples, patient information associated with confirmed matches (e.g., confirmed by an administrator through the patient membership portal module **402**, confirmed by a healthcare provider using a mobile device through the host module **312**) can be stored in the patient information data store **408**. In some examples, a patient matching user interface (UI) is provided (e.g., displayed on a mobile device) and can be used by a healthcare provider to search for patients and establish, record and/or confirm relationships between patient records in different systems that are related to a single patient.

In some examples, the demographics information **420** includes information that can be used to identify any patient that has been established in the system. In some examples, the demographics information **420** can be used to search for patients, discussed in further detail herein. Example demographics information can include name, age and/or gender. In some examples, the data pointer cache **422** stores identifiers associated with detailed patient data. In some examples, the identifiers point to particular data stores, in which to be retrieved patient data/information is stored. In this manner, retrieval performance (e.g., speed) can be improved. In some examples, the patient-to-provider index **424** maps particular patients to one or more healthcare providers, and/or particular healthcare providers to one or

more patients. For example, a patient can be treated by a plurality of healthcare providers (e.g., members of a patient care team, discussed below). As another example, a healthcare provider can treat a plurality of patients. In some examples, the patient-to-facility index **426** maps particular patients to one or more facilities and/or facility systems. In some examples, a patient can be mapped to particular facilities based on respective MRNs of the patient at the respective facilities. For example, a healthcare continuum for a particular patient can include a hospital and a clinic. In this example, the patient-to-facility index can map the patient to the MRN of the hospital and the MRN of the clinic.

In some implementations, the provider management portal module **406** provides an interface (e.g., web portal) to enable members of a healthcare organization (e.g., ACO) to update healthcare provider directory information and/or healthcare provider-to-facility relationships. For example, a physician can be associated with one or more facility systems of the healthcare organization and credentials (e.g., for log on and/or authentication) can be provided to enable the physician to access patient data/information provided from the one or more facility systems.

In some examples, the facility directory **430** provides a directory of the facilities interfaced to by the system (e.g., the DMS **301**). In some examples, the facility directory **430** also provides configuration parameters to enable communication (messaging) between the system and computing devices associated with the respective facilities. In some examples, the provider directory **432** includes a directory of healthcare providers (e.g., nurses, physicians, specialists, and the like) that are able to access patient data/information through the system (e.g., the DMS **301**). In some examples, the provider-to-facility index **434** maps each healthcare provider (e.g., in the provider directory) to one or more facilities. For example, a healthcare provider can treat patients at multiple facilities. In some examples, the provider-to-facility index **434** securely stores credentials of healthcare providers for facilities that the healthcare provider is mapped to. For example, a healthcare provider can have first credentials for accessing patient data/information at a first facility, and can have second credentials for accessing patient data/information at a second facility. In some examples, the provider-to-facility index **434** supports single sign-on functionality discussed in further detail herein.

An example data flow will be discussed to illustrate implementations of the present disclosure. It is appreciated that implementations of the present disclosure are equally applicable to other data flows. The example data flow can be initiated in response to a request received from a mobile device (e.g., the mobile device **102**). In some examples, the request includes a user identifier, a device identifier, a patient identifier, patient data identifiers, patient information identifiers and additional data identifiers. In some examples, the user identifier can be used to determine the particular user that has issued the request, and the device identifier can be used to determine the particular device that transmitted the request. In some examples, the patient identifier identifies the particular patient that is the subject of the request, the patient data identifiers identify the particular patient data that has been requested, the patient information identifiers identify the particular patient information that has been requested, and the additional data identifiers identify additional data that has been requested. For example, the patient data identifiers can indicate that patient vital data has been

requested, and the additional data identifiers can indicate that vitals alarm data and vital data trend visualizations have also been requested.

In the example data flow, the web module **310** receives the request and processes the request to validate the request and to authenticate the user, who submitted the request (e.g., based on the user identifier and/or the device identifier). Upon validation and authentication, the web module **310** provides the request to the host module **312**. The host module **312** processes the request, as discussed above. In some examples, it can be determined that patient data/information required to fulfill the request can be provided from the data cache module **314** (e.g., reposed mode). In such examples, the patient data/information is provided to the host module **312** from the data cache module **314**. In some examples, it can be determined that that patient data/information required to fulfill the request is to be retrieved from one or more data sources across a healthcare continuum of the patient (e.g., federated mode).

In some examples, if patient data/information required to fulfill the request is to be retrieved from one or more data sources across the healthcare continuum (e.g. federated mode), request information (e.g., assembled by the host module **312**, as discussed above) is provided to the adapter module **316** by data cache module **314**. In some examples, the adapter module **316** accesses information stored in the directory store **410** to request data from one or more facility systems (e.g., the facility system **304**). For example, the adapter module **316** can be aware of which facility systems to retrieve patient data/information from (e.g., based on the patient-to-facility index **426**) and can access the provider-to-facility index **434** to retrieve user credentials for the particular provider (e.g., user that issued the request). In this manner, the adapter module **316** can provide appropriate user credentials to respective facility systems for patient data/information retrieval.

In some examples, the adapter module **316** sends requests to identified facility systems, each request identifying patient data/information and providing appropriate user credentials. In some examples, respective host modules (e.g., the host module **332**) of the facility systems receive the requests from the adapter module **316**, and can process the requests as similarly discussed above with reference to the host module **312**. The respective host modules fulfill the requests and provide the requested patient data/information back to the adapter module **316**. In some examples, the adapter module **316** provides the retrieved patient data/information to the host module **312**, which completes processing of the request, as discussed above, and provides a response to the mobile device that issued the request.

As discussed at the outset, the present disclosure provides a healthcare provider, or user of the mobile device **102**, with secure, remote access to patient data and/or patient information. Example patient data can include physiological data. In some examples, physiological data can be obtained from patient monitoring device(s). In some examples, physiological data can be obtained by a local healthcare provider (e.g., a nurse, or physician measuring blood pressure, temperature, heart rate). In some examples, physiological data can be recorded in one or more patient records (e.g., EMRs). In the example case of a maternity patient, patient data can include delivery progress information such as cervical exam status, membrane status, gravida, para, epidural status, and/or whether the patient is attempting a vaginal birth after cesarean (VBAC). In some examples, the term patient information refers to information corresponding to a particular patient that is, for example, input into the information

system 142 by the local healthcare provider. Example patient information can include the patient's name, the name of the doctor(s) assigned to the patient, the nurse(s) assigned to the patient, a facility identification, a patient bed identification, a summary of patient data, and/or chart annotations. The term patient information can also refer to patient information provided from one or more patient records (e.g., EMRs).

The patient data and/or patient information provided to the remotely located user can be provided as real-time data, and/or as historical data and information. The patient data and/or patient information is communicated between the mobile device 102 and the DMS 160, 160' using a secure connection that is established over the network 106. A secure log-in, or sign-on process is provided, which is preferably compliant with the provisions of the Health Insurance Portability and Accountability Act (HIPAA). The secure sign-on authenticates the identity of the user of the mobile device 102 based on a unique user ID and password combination. Both the user ID and the password must be correct in order to establish the secure communication between the mobile device 102 and the DMS 160, 160'.

In some examples, a census, or patient list is provided, which captures a variety of the information and/or data described herein that is associated with each of one or more monitored patients 150. Strip charting is also provided, in which patient data and/or information can be presented to the user in graphical form. In the example case of a maternity patient, a fetal strip and maternal contraction information can be provided for a particular patient 150. More specifically, the particular patient 150 is selected from the patient list, and the patient information and/or data is subsequently presented. The presented information and/or data can include a fetal strip and maternal contraction waveform, the patient name, the hospital name, the patient room and/or bed number, and the date and time. The strip charting can provide a real-time view of the patient data, as well as a historical view of the patient data. More specifically, the waveform display can be updated in real-time, such that the user of the mobile device 102 observes the patient data as it occurs and/or is recorded. The user can scroll through the waveform display, to view historical patient data, as described in further detail below.

Several navigation features can be provided that enable the user to manipulate a view of the waveform display. In some implementations, the user can zoom in/out of the displayed image. In this manner, the user can view very specific waveform information, and/or other waveform micro-characteristics by zooming in, for example, and/or can view patterns or other waveform macro-characteristics by zooming out, for example. In some implementations, the user can scroll forward or backward through the waveform display. In this manner, the user can view historical patient data.

A patient data display can also be provided. In some implementations, the patient data display can overlay the strip charting described herein. In other implementation, the patient data display can be provided as an overlay, and/or as a separate display. The patient data display can include, but is not limited to, the patient's name, age, fetal gestation, gravida, parity, cervical exam information, and physician name.

Implementations of the present disclosure can be realized on any one of a number of operating systems, or platforms 302 associated with the particular mobile device 102. Example platforms include, but are not limited to, RIM Blackberry, Apple iOS and/or OS X, MS Pocket PC, Win

Mobile (Pocket PC, Smartphone), Win Mobile (standard, professional) and/or any other appropriate platforms (e.g., Google Android, and Hewlett-Packard WebOS, Microsoft Windows, Unix, Linux).

As discussed in detail herein, implementations of the present disclosure are directed to systems and methods of providing integrated and unified views of patient data and patient information from disparate data sources and/or products. More particularly, implementations of the present disclosure provide integrated and unified views of patient data and patient information retrieved from across a healthcare continuum. In some examples, the healthcare continuum can include a plurality of disparate clinical data sources. In some examples, a clinical data source can correspond to one or more categories of healthcare services. Example categories can include emergency medical services (EMS), outpatient services, inpatient services, ambulatory services, post-acute services, home services and stand-alone services. Example EMS can include emergency departments (e.g., emergency room (ER) of a hospital), urgent care facilities and transport (e.g., ambulance). Example outpatient services and/or inpatient services can include hospitals and/or critical access hospitals (CAHs). Example ambulatory services can include clinics, physicians groups/offices, surgery centers and pre-acute care. Example post-acute services can include skilled nursing facilities, long-term care hospitals, rehabilitation centers and home healthcare. Example stand-alone services can include imaging centers (e.g., MIR), oncology centers, laboratories, virtual call centers and retail clinics.

FIG. 5 depicts an example platform 500 for providing integrated and unified views of patient data and patient information. The example platform 500 includes one or more product applications 502 and core components 504. The example platform enables the transfer of patient data/information to/from one or more data sources 506 for display on a mobile device (e.g., the mobile device 102). In some examples, the example platform 500 is provided as one or more computer-executable programs that are executed using one or more computing devices (e.g., the DMS 160, 160'). Example data sources 506 can include one or more medical devices (e.g., bedside monitors), one or more EMRs, health information exchange (HIE) data 512, image data 514 (e.g., x-ray data), and sensor data 516.

In some implementations, the example platform 500 can include a mobile application platform 520. An example mobile application platform 520 can include the mobile application platform disclosed in U.S. application Ser. No. 13/716,974, filed Dec. 17, 2012, and which claims the benefit of U.S. Prov. App. No. 61/579,954, filed Dec. 23, 2011, the disclosures of which are expressly incorporated herein by reference in their entireties.

In some examples, the mobile application platform 520 separates native graphical user interface (GUI) and operating system components from the application logic. In this manner, the mobile application platform 520 translates and interprets application logic into the native languages of each operating system of mobile devices to/from which patient data/information is to be transferred, and embraces the unique properties, features, function, and usability of each operating system. In some implementations, the mobile application platform 520 embodies a template-based approach, where one or more templates are provided, each template corresponding to a view of patient data/information that is to be presented on a mobile device. In some examples, and as discussed in further detail herein, default templates can be provided, which provide default views of patient

data/information. In some examples, custom templates can be provided, and can include templates customized by a user of a mobile device.

In some examples, the mobile application platform **520** processes patient data/information based on a template that defines a view to be displayed on the mobile device. In some examples, the mobile application platform **520** generates instructions for rendering graphics based on the patient data/information and the template, and provides instructions to the mobile device, the mobile device executing the instructions to provide the template-based view of the patient data/patient (e.g., rendering the patient data/information in a view displayed on the mobile device).

In some examples, the product applications **502** can include medical software applications that enable mobility in healthcare. For example, products can enable patient information and patient data (e.g., waveforms and other critical data from EMRs, bedside monitors and devices, pharmacy, lab, and other clinical information systems) to be securely and natively accessed by healthcare providers on mobile devices. Example products can include an obstetrics (OB) product (e.g., AirStrip OB provided by AirStrip Technologies, LLC), a cardiology product (e.g., AirStrip CARDIO provided by AirStrip Technologies, LLC), a patient monitoring product (e.g., AirStrip PATIENT MONITORING provided by AirStrip Technologies, LLC), and an EMR extension product (e.g., AirStrip EMR EXTENDER provided by AirStrip Technologies, LLC).

FIG. 6 depicts example components and sub-components that can be included in the core components **504** of FIG. 5. In some examples, each component and/or sub-component can be provided as one or more computer-executable programs that can be executed using one or more computing devices (e.g., computing devices of the DMS **160**, **160'** of FIGS. 1 and 2). In some examples, the core components provide secure data access and data transport, single sign-on and profile/context management, interoperability (data adapters and interfaces), intelligent message routing, master patient indices (e.g., EMPI) and care collaboration.

In the depicted example, the core components **504** include a security component **600**, a care coordination and collaboration interfaces component **602**, a data and workflow integration component **604**, a data source adapters component **606** and a services component **608**. In the depicted example, the security component **600** includes a single sign-on sub-component **610** and a user context/profiles sub-component **612**. In the depicted example, the care coordination and collaboration interfaces component **602** includes a voice sub-component **614**, a video sub-component **616** and a messaging sub-component **618**. In the depicted example, the data and workflow integration component **604** includes a patient index (or indices) component **620** and an intelligent routing sub-component **622**. In some examples, the data source adapters component **606** can include adapter services sub-components **624** (e.g., the adapter services module **324** of FIG. 3). In the depicted example, the services component **608** includes a reporting and analytics sub-component **626**, a clinical transformation sub-component **628** and an implementation and support sub-component **630**.

In some examples, the single sign-on sub-component **610** supports single sign-on functionality, discussed herein. In some examples, a user can be authenticated once (e.g., by providing log-in credentials to an application executed on a mobile device) and can be provided access to data across a plurality of data sources, without being authenticated for each data source individually. In some examples, the user context/profiles sub-component **612** supports user-specific

customizations based on a context of the user and/or a profile of the user, as discussed in further detail herein. Example contexts can include the user being an attending physician at one hospital and a part-time physician at another hospital. In some examples, one or more profiles can be associated with the user, each profile reflecting one or more customizations associated with the particular user. For example, the user can customize a default view that can be displayed on a mobile device, to provide a customized view. Consequently, after the user is authenticated, one or more user-defined (user-customized) views can be provided to the mobile device.

In some examples, the care coordination and collaboration interfaces component **602** supports collaboration between members of a patient care team. For example, a patient care team can include a physician, a consultant, a specialist, an intensivist and a nurse. In some examples, the voice sub-component **614** provides voice-based collaboration between care team members (e.g., teleconferencing). In some examples, the video sub-component **616** provides video-based collaboration between care team members (e.g., video conferencing). In some examples, the messaging sub-component **618** provides messaging-based collaboration between care team members (e.g., SMS/MMS text messaging). In some examples, the care coordination and collaboration component **602** provides security in remote collaboration between care team members (e.g., secure teleconferencing, secure video conferencing and/or secure messaging).

In some examples, the data and workflow integration component **604** integrates data from a plurality of data sources and routes data for display on mobile devices. In some examples, the patient index (or indices) component **620** provides one or more indices for mapping users to facilities and/or patients. In some examples, one or more indices can be provided to associate a user (e.g., a physician) with a facility or multiple facilities (e.g., hospitals), to associate a patient with a facility or multiple facilities, and/or to associate a user with one or more patients. In some examples, an index can be based on an ACO. In some examples, the ACO includes one or more healthcare providers across a healthcare continuum and can provide cross-access to patient data/information. In some examples, the intelligent routing sub-component **622** provides intelligent routing functionality, discussed above.

In some examples, the data source adapters component **606** provides adapter functionality. In the depicted example, the services component **608** includes a reporting and analytics sub-component **626**, a clinical transformation sub-component **628** and an implementation and support sub-component **630**.

As discussed in further detail herein, patient data and patient information can be provided from one or more disparate patient data sources (e.g., examples depicted in FIG. 5). In some examples, a patient can be associated with one or more healthcare services across the healthcare continuum. Consequently, and for each patient, patient data and patient information can be distributed across the healthcare continuum. For example, a patient can be taken to a hospital by EMS (e.g., ambulance), can be treated in an emergency department of the hospital (e.g., ER), can stay in the hospital on an inpatient basis, can frequent a rehabilitation center (e.g., physical therapy), can be undergoing home healthcare (e.g., home nursing care), and patient samples can be sent to a laboratory for analysis (e.g., blood analysis provided by an external laboratory). In this example, treatment of the particular patient touches multiple facilities across the health-

care continuum, and each facility can generate its own patient data, patient information and patient records (EMRs).

In general, an EMR can be described as a digital medical record provided as an electronic document that can be processed (e.g., read from/written to) by one or more computer programs executed by one or more computing devices. Further, each entity or organization (e.g., clinic, hospital, physician, rehabilitation center, laboratory) that treats a patient can include its own, stand-alone information system that provides an EMR that is specific to the information system. Consequently, multiple, disparate EMRs can be provided for a single patient across the healthcare continuum. Within the context of the example above, a first EMR can be provided for the patient by an ambulance service that transported the patient to the hospital, a second EMR can be provided for the patient by the hospital, a third EMR can be provided for the patient by the rehabilitation center and a fourth EMR can be provided for the patient by a nursing company that is providing home nursing care to the patient. In some examples, and as noted above, EMRs can be generated from disparate information systems. Consequently, format and syntax of one EMR can be different from the format and syntax of another EMR.

In some examples, historical patient data and information can be provided for viewing by a healthcare provider, as well as providing real-time patient data for viewing to the healthcare provider. Extending the example above, the patient can be re-admitted to the hospital on an inpatient basis and can be connected to one or more patient monitoring devices that generate patient physiological data based on patient physiological activity. In accordance with implementations of the present disclosure, and as discussed in further detail herein, patient data and information from one or more of the first EMR, the second EMR, the third EMR and the fourth EMR, as well as real-time patient data can be provided for display to a healthcare provider (e.g., a physician attending to the patient) on a mobile device in an integrated and unified manner. For example, real-time and/or historical patient physiological data can be provided for display by multiple products (e.g., a cardiology product and a patient monitoring product). Implementations of the present disclosure enable integration and unification of the patient physiological data across the products.

In accordance with implementations of the present disclosure, patient data can be displayed to a user of a computing device. In some implementations, the user provides log-in credentials to an application that is executed on the mobile device. For example, the application can open and can provide a log-in screen for the user to provide credentials. In some examples, the credentials can include a personal identification number (PIN). If the PIN is not authenticated (e.g., the user-input PIN is not the same as a pre-stored PIN), an error is displayed. If the PIN is authenticated (e.g., the user-input PIN is the same as a pre-stored PIN), a sites screen or a base screen can be displayed. In some examples, authentication can be provided based on a personal identifier (e.g., the PIN) and another identifier. In some examples, another identifier can include an identifier that is unique to a mobile device that the user is using. For example, the PIN and a unique device identifier can be provided for authentication.

FIG. 7 depicts an example sites screen 700. In some implementations, the sites screen 700 provides a GUI including one or more site icons that can be selected (e.g., clicked on) by the user. In some examples, a site can include a specific facility (e.g., hospital clinic), a system of facilities

(e.g., a hospital system including one or more hospitals, one or more clinics, and/or one or more laboratories, and the like). In some examples, an index (e.g., a user-facility index) can be accessed based on an identifier associated with the user, to determine the one or more site icons that are to be displayed to the user. In some examples, in response to the PIN being authenticated, an identifier associated with the user can be provided to the DMS 160', for example, by the mobile device 102 (see FIGS. 1 and 2). In some examples, the DMS 160' stores an index (e.g., a user-facility index) that is accessed based on the identifier. In some examples, the index maps the identifier associated with the user to one or more facilities that the user is associated with. In response, the DMS 160' provides instructions to the mobile device 102 to display the sites screen 700 including the one or more site icons 702, 704, 706, 708, 710, 712, 714, 716, each site icon being a graphical representation of a facility of facilities that the user is associated with.

In some implementations, and as noted above, the user can be associated with more than one site (e.g., 702, 704, 706, 708, 710, 712, 714, 716). In some implementations, the user is affiliated with a single site, which is included in a network that includes a plurality of inter-communicating sites associated therewith. In some examples, a site can include a medical center, a dispensary, a hospital, an infirmary, a surgery center, an ambulatory setting, a nursing home, a rest home, a sanatorium, a sanitarium, or any other appropriate healthcare facility. In some implementations, the site screen 700 can provide a summary of each site and/or specific sites, with which the user is associated. In some examples, a site summary can include a plurality of selectable icons (e.g. a site access icon, a site information icon, a patient information icon, etc.). In some implementations, each site summary can include attributes (e.g. patient counts).

User input can be provided to the site screen 700, the user input indicating a selection of a site icon of the one or more site icons. In some examples, user input can include touching of a touchscreen display with a digit (e.g., finger), a stylus, and/or other pointing device, as well as with a digital cursor and/or a keypad.

In some implementations, a base screen can be displayed. In accordance with implementations of the present disclosure, and as discussed in further detail herein, the base screen can include a menu. In some examples, the menu provides a GUI, through which the user can request display of patient data/information. In some examples, the menu is a user-specific menu. In some examples, the menu is specific to one or more user contexts. In some examples, the menu is specific to a site selected by the user. In some examples, the base screen is displayed in response to the PIN being authenticated. In some examples, the base screen is displayed in response to user input to the sites screen.

In accordance with implementations of the present disclosure, the menu is provided as a slide-out menu that is animated in response to user selection of an icon. In some examples, the menu can be animated such that the menu appears to slide-out from an edge of the base screen (e.g., left-side edge). In some examples, the menu is animated such that the menu appears to slide-in to the edge of the base screen in response to user selection of an icon from the menu.

In accordance with implementations of the present disclosure, the menu can include icon groups. In some examples, the icon groups can be provided as default icon groups. For example, a default icon group can be displayed in the menu, the default icon group being agnostic to the

particular user (e.g., displayed for any user). In some examples, the icon groups can include user-customized icon groups. For example, the menu can include a user-customized icon group that is specific to (e.g., that was defined by) the user. In some examples, the icon groups can include user-specific and/or site-specific icon groups. For example, an icon group can include a workflow icon group that is specific to the role of the user (e.g., an attending physician) at a specific facility.

FIGS. 8 illustrates an example screen-shot of a base screen 800 that includes a menu 802. The example base screen 800 of FIG. 8 is user-specific and site-specific. For example, the base screen 800 can be displayed in response to user selection of a site icon (e.g., the site icon 704 of FIG. 7). Consequently, a site identifier 816 can be provided to indicate the site, to which the menu 802 is specific. In some examples, a request for the base screen is provided to the DMS 160' in response to user selection of an icon from the sites screen 700. In some examples, the request indicates the site that was selected. In some examples, a user-facility index can be accessed to determine a configuration of a menu to be displayed in the base screen. For example, and for a given site (facility), the user can have an associated profile, user-defined patient groups, context-specific workflows and/or facility-specific workflows. Consequently, the DMS 160' can provide instructions for displaying a user-specific, site-specific base screen, such as the example base screen 800 of FIG. 8. More particularly, the instructions can include instructions for displaying a user-specific, site-specific menu 802 for the base screen 800.

In the depicted example, the menu 802 provides icons for initiating respective displays of patient data/information. In the menu 802, the icons are displayed in icon groups, or menu groups 804a, 804b. It is appreciated that more or fewer icon groups can be displayed. In the example of FIG. 8, the icon group 804a can be provided as a default icon group. For example, the icon group 804a includes icons "My Patients" 806, "Recently Viewed" 808, and "Find Patients" 810. In some examples, the icons 806, 808, 810 are default icons. That is, for example, the icons 806, 808, 810 are not specific to the user and/or the facility (e.g., the icons 806, 808, 810 are displayed regardless of the particular user and/or the particular facility). In some examples, the icon group 804a can be customized by the user. For example, the user can define a patient group (e.g., "My Cardio Patients," "My OB Patients") and can associate one or more patients with the group. Consequently, an icon that is representative of a user-defined group can be displayed in the icon group 804a.

In the example of FIG. 8, the icon group 804b can be provided as a user-specific and facility-specific icon group. For examples, the icon group 804b can be representative of a workflow (e.g., "Cardio") associated with the user at the particular facility (e.g., as indicated by the identifier 816). Consequently, the icon group 804a can include icons that are relevant to the particular workflow. In the depicted example, the icon group 804b includes an "In Basket" icon 812 and an "EMS" icon 814. In some examples, a workflow can include one or more tasks to be performed by the user as part of the user's role at a particular facility.

In some implementations, a request can be provided to the DMS 160' in response to user selection of an icon from the menu 802. In the example of FIG. 8, the user can select the "My Patients" icon 806. In response, a request can be provided to the DMS 160', the request indicating a request for a list of all patients that the user is associated with. The DMS 160' can provide a response that includes instructions to display a list of all patients associated with the user and

can include patient data/information for display. In some examples, and in response to the user selection of the "My Patients" icon 806, the menu 802 is animated to slide-in to the edge of the screen.

FIG. 9 depicts an example patient data dashboard 900. In some implementations, the dashboard can provide a timeline 902 of patient data and/or patient information associated with a particular patient. In some examples, the timeline 902 provides an interactive, chronological ordering of medical events associated with the particular patient. More particularly, the timeline 902 can include graphical representations of one or more medical events provided in chronological order. In the depicted example, example events include hospital admission (event 904a, 904e), hospital discharge (event 904d), alarms (events 904b, 904g), lab results (event 904e), ECG testing (event 9040, and/or any other appropriate event. In some examples, each graphical representation of an event provides summary information associated with the event (e.g., date/time of the event, type of event, notes describing the event.

In some examples, event data can be retrieved from one or more information systems. In some examples, event data can be retrieved from one or more EMR systems, ECG management systems, perinatal systems, and/or any appropriate clinical information system. The event data can be processed to provide the respective graphical representations of the events.

In some implementations, the graphical representations of the events are interactive. For example, a user can tap-on a graphical representation of a particular event and, in response, detailed information of the event can be retrieved and can be displayed. In this manner, the user can have quick access to detailed patient information with the timeline 902 providing overall context for the detailed patient information.

In some implementations, the timeline is scrollable forward or backward in time to provide a complete picture of events provided in the EMR. In some examples, a user swiping motion on the touchscreen display can induce scrolling of the timeline to reveal previously un-displayed events and to hide previously displayed events.

In some implementations, the dashboard 900 includes quick access to other patient information. In the depicted example, the dashboard 900 includes icons 906, 908, the icon 906 being associated with a patient monitor and alarms and the icon 908 being associated with patient laboratory work and medications. In some examples, and in response to the user tapping on the icon 906, patient data can be displayed (e.g., patient vital display). In some examples, and in response to the user tapping on the icon 908, laboratory and medication information can be displayed.

FIGS. 10A-10D illustrate more detailed timeline views in accordance with implementations of the present disclosure. More specifically, FIGS. 10A-10D provide example screen-shots of a "Timeline" screen 1000 that can be displayed in response to user selection of a "Timeline" icon 1002 in a patient summary screen (not shown). In this example, the screen 1000 is user-specific and patient-specific. In some examples, the screen 1000 can be site-specific (e.g., specific to General Hospital). In some examples, the screen 1000 can be site-agnostic.

The screen 1000 includes a display region 1004 and a menu 1006. The menu 1006 provides icons for applying filters to a timeline 1007 displayed in the display region 1004. In the depicted example, the menu 1006 includes a "Summary" icon 1008, a "Vitals" icon 1010, a "Labs" icon 1012, a "Medications" icon 1014, an "Imaging" icon 1016,

a “Documents” icon **1018**, and an “ECGs” icon **1020**. In the depicted example, the icon **1008** is selected.

The timeline **1007** provides an interactive, chronological ordering of medical events associated with the particular patient. More particularly, the timeline **1007** includes graphical representations of one or more medical events provided in chronological order. In the depicted example, each medical event corresponds to an event category. Example event categories include patient vitals, laboratory results, medications, imaging, documents and ECGs. In some examples, the example categories respectively correspond to the icons **1010**, **1012**, **1014**, **1016**, **1018**, **1020**.

In the example of FIGS. **10A** and **10B**, the timeline **1007** includes graphical representations corresponding to an imaging event **1030**, medication events **1032a**, **1032b**, **1032c**, **1032d**, ECG events **1034a**, **1034b**, an activation event **1036**, a procedure event **1038**, orders events **1040a**, **1040b**, note events **1042a**, **1042b**, alarm events **1044a**, **1044b**, a consultation event **1046**, and a vitals event **1048**. In the example of FIGS. **10A** and **10B**, the screen **1000** of FIG. **10A** depicts a first portion of the timeline **1007**, and the screen **1000** of FIG. **10B** depicts a second portion of the timeline **1007**, the first portion being earlier in time than the second portion. In some examples, user input can be provided to the touchscreen display to induce scrolling (e.g., left-right scrolling) of the timeline. For example, a user swiping gesture from right-to-left in the screen **1000** can result in scrolling of the screen from displaying the first portion (FIG. **10A**) to displaying the second portion (FIG. **10B**).

In the example of FIGS. **10A** and **10B**, the screen **1000** depicts approximately a 12-hour period from edge-to-edge (e.g., left edge to right edge). In some examples, a marker can be provided to delineate time periods. For example, FIG. **10B** depicts a date marker **1050** indicating that events occurring to the left of the date marker **1050** occurred on or before the indicated date (e.g., Jul. 19, 2012), and that events occurring to the left of the date marker **1050** occurred after the indicated date.

In some implementations, the extent of a time period displayed in the screen **1000** at a given moment can be adjusted. In some examples, the user can zoom in, to provide a more detailed timeline view (e.g., a shorter time period). In some examples, the user can zoom out to provide a less detailed timeline view (e.g., a longer time period). For example, and as noted above, the screen **1000** of FIGS. **10A** and **10B** depicts approximately a 12-hour period. The user can provide user input to zoom in, such that the screen depicts a shorter time period (e.g., 6 hours, 1 hour). The user can provide user input to zoom out, such that the screen depicts a longer time period (e.g., 24 hours, 1 week, 1 month, 6 months, 1 year, 2 years). In some examples, information and/or graphics provided in the graphical representations and/or the size of graphical representations can be adjusted based on the time period being displayed and/or the number of graphical representations being displayed. In this manner, crowding of the screen (which can make review of the timeline difficult) can be inhibited.

In accordance with implementations of the present disclosure, each graphical representation can include summary patient data/information, as well as event-specific information. For example, each medication event **1032a**, **1032b**, **1032c**, **1032d** includes a time and date (e.g., a timestamp) associated with the respective medication event, and includes a brief description of the respective medication event. As another example, each alarm event **1044a**, **1044b** includes a time and date (e.g., a timestamp) associated with

the respective alarm event, and includes a graphical (e.g., waveform) and textual patient data that is specific to the respective alarm event. As another example, each ECG event **1034a**, **1034b** includes a time and date (e.g., a timestamp) associated with the respective ECG event, and includes one or more graphical (e.g., waveform) and textual patient data that are specific to the respective ECG event. As another example, the image event **1030** includes a time and date (e.g., a timestamp) associated with the image event, and includes graphical (e.g., thumbnail images) and textual patient data that is specific to the respective imaging event. For example, thumbnail images can be provided that correspond to the actual images (e.g., x-rays, MRIs, CT scans) associated with the respective event.

In some implementations, graphical representations can include a generic icon representative of an event category associated with a medical event. In this manner, the user is able to readily discern event categories between events on the timeline. For example, each medication event **1032a**, **1032b**, **1032c**, **1032d** includes an icon depicting a generic prescription bottle. As another example, each orders event **1040a**, **1040b** includes an icon depicting a generic clipboard. In some examples, icons provided in a graphical representation can be specific to a sub-category of an event. In some examples, a consultation (e.g., between physicians treating a patient) can occur in-person, by teleconference, or video-conference). Consequently, a graphical representation corresponding to a consultation event can include an icon that is specific to the manner in which the underlying consultation was conducted. For example, the consultation event **1046** includes a camera icon visually indicating that the underlying consultation was conducted by video-conference. In some examples, a telephone icon can visually indicate that an underlying consultation was conducted by teleconference, and a caricature icon (e.g., depicting one or more persons) can visually indicate that the underlying consultation was conducted in-person. In some examples, medication can be provided to a patient in various manners. For example, medication can be administered orally (e.g., pills, liquid), or intravenously (e.g., an injection (shot), continuous IV infusion). Consequently, a graphical representation corresponding to a medication event can include an icon that is specific to the manner in which the underlying medication was administered.

In some implementations, and as discussed above, graphical representations can provide actual patient data/information. For example, each alarm event **1044a**, **1044b** depicts actual waveforms and textual values. In some examples, graphical representations can depict actual patient data/information in caricatured form. For example, each note event **1042a**, **1042b** can include a caricatured depiction of actual notes. In some examples, notes such as physician notes and/or nursing notes can be digitally entered (e.g., into an EMR). In some examples, the caricatured depiction includes the text of the actual notes, but the text is displayed in a font that is representative of handwriting, as depicted in FIGS. **10A** and **10B**. In some examples, the caricatured depiction can also include the “handwritten” notes displayed on a notepad, as depicted in FIGS. **10A** and **10B**. In this manner, the actual text is provided, but in caricatured form, such that the user is quickly able to discern note events from other displayed events in the timeline.

In accordance with implementations of the present disclosure, graphical representations of events are user-selectable to induce display of a corresponding screen associated with a respective event. In some examples, a user can select an event from the timeline (e.g., tap on the event), and a

screen can be displayed corresponding to the event. For example, user input (e.g., tap on) to the imaging event **1030** can be received, and in response, an imaging screen can be displayed (e.g., replacing the screen **1000**) that provides further detail of the event, and/or larger images associated with the event. As another example, user input (e.g., tap on) to the alarm event **1044a** can be received, and in response, an alarms screen can be displayed (e.g., replacing the screen **1000**) that provides further detail of the event, and/or larger waveform(s) associated with the event.

In some implementations, graphical representations provided in the timeline **1007** are interactive. More specifically, user input can be provided to a graphical representation of an event and the event can be modified in response to the user input. For example, user input can be provided to the note event **1042a** and can indicate a user command to scroll. In response to the user input, the notes displayed in the note event **1042a** can be scrolled (e.g., upward-downward, left-right) to reveal additional notes not originally displayed. In this manner, the user can read the extent of the notes without having to navigate away from the screen **1000** (e.g., to a notes screen). As another example, user input can be provided to the alarm event **1044a** and can indicate a user command to scroll. In response to the user input, the waveform displayed within the alarm event **1044a** can be scrolled (e.g., upward-downward, left-right) to reveal additional waveform data not originally displayed. In this manner, the user can review the extent of the waveform without having to navigate away from the screen **1000** (e.g., to a waveform screen).

In the example of FIGS. **10A** and **10B**, the timeline **1007** is an unfiltered timeline and includes all events associated with the user, regardless of event category. For example, and in response to selection of the summary icon **1008**, and the timeline icon **1002**, an unfiltered timeline associated with the respective patient is displayed (e.g., the timeline **1007**).

In some implementations, the timeline **1007** can be filtered to display specific event categories. In some examples, the timeline **1007** can be filtered based on the icons **1010**, **1012**, **1014**, **1016**, **1018**, **1020** to provide respective filtered timelines. For example, FIGS. **10C** and **10D** depict filtered timelines **1007'**, **1007''**, respectively. More particularly, the timeline **1007'** of FIG. **10C** is displayed in response to user selection of the icon **1012** and includes graphical representations corresponding to laboratory result events for the particular patient. The timeline **1007''** of FIG. **10D** is displayed in response to user selection of the icon **1014** and includes graphical representations corresponding to medication events for the particular patient.

FIG. **11** depicts an example process **1100** that can be executed in accordance with implementations of the present disclosure. In some examples, the example process **1100** can be provided in one or more computer-executable programs that can be executed using one or more computing devices (e.g., the mobile device **102** and/or the DMS **160**, **160'**).

A command to display a timeline screen is received (**1102**). In some examples, user input is provided to a mobile device, the user input indicating a user command to display a timeline screen. Patient data and/or patient information are retrieved (**1104**) and one or more medical events are determined (**1106**). In some examples, in response to the user input, patient data/information associated with a particular patient is retrieved, and information regarding medical events is determined. In some examples, retrieved patient-specific data and/or medical event information are processed to determine the one or more medical events to be displayed. Instructions are provided for displaying the timeline screen

(**1108**). The timeline screen is displayed on the mobile device. For example, the mobile device processes the instructions to display the timeline screen. In some examples, the timeline screen displays a timeline including the one or more medical events, each medical event providing summary patient data/information associated with an underlying event.

It is determined whether a particular medical event has been selected (**1110**). In some examples, user input to the timeline screen can be determined, the user input indicating selection of a particular medical event from the timeline. If it is determined that a particular medical event has been selected, detailed event information and/or underlying patient data/information can be retrieved, and instructions are provided for displaying an event-specific screen (**1112**).

If it is determined that a particular patient has not been selected, it is determined whether a new screen is to be displayed (**1114**). For example, the user can choose to navigate to a different screen from the timeline screen. If it is determined that a new screen is to be displayed, the new screen is displayed (**1116**). If it is determined that a new screen is not to be displayed, the example process **1100** loops back.

Implementations of the present disclosure can be provided using digital electronic circuitry, or in computer hardware, firmware, software, or in combinations thereof. In some examples, implementations can be provided one or more computer program products, e.g., a computer program tangibly embodied in a machine-readable storage device, for execution by, or to control the operation of, data processing apparatus, and/or a programmable processor, a computer, or multiple computers. A computer program can be written in any form of programming language, including compiled or interpreted languages, and it can be deployed in any form, including as a stand-alone program or as a module, component, subroutine, or other unit suitable for use in a computing environment. A computer program can be deployed to be executed on one computer or on multiple computers at one site or distributed across multiple sites and interconnected by a communication network. Such a computer program can include modules and/or code segments for executing one or more of the features, aspects and/or implementations provided herein.

Operations in accordance with implementations of the present disclosure can be performed by one or more programmable processors executing a computer program product to perform functions by operating on input data and generating output. By way of example, a computer program product can include modules and/or code segments corresponding to each of the method steps, aspects and/or features provided herein. Method steps can also be performed by, and apparatus of the present disclosure can be implemented as, special purpose logic circuitry, e.g., an FPGA (field programmable gate array) or an ASIC (application-specific integrated circuit).

Processors suitable for the execution of a computer program include, by way of example, both general and special purpose microprocessors, and any one or more processors of any kind of digital computer. Generally, a processor will receive instructions and data from a read-only memory or a random access memory or both. Elements of a computer can include a processor for executing instructions and one or more memory devices for storing instructions and data. Generally, a computer can also include, or be operatively coupled to receive data from or transfer data to, or both, one or more mass storage devices for storing data, e.g., magnetic, magneto-optical disks, or optical disks. Information

carriers suitable for embodying computer program instructions and data include all forms of non-volatile memory, including by way of example semiconductor memory devices, e.g., EPROM, EEPROM, and flash memory devices; magnetic disks such as internal hard disks and removable disks; magneto-optical disks; and CD-ROM and DVD-ROM disks. The processor and the memory can be supplemented by, or incorporated in special purpose logic circuitry.

The present disclosure can be implemented in a system including, but not limited to the example systems described herein, which include a back-end component, e.g., as a data server, or that includes a middleware component, e.g., an application server, or that includes a front-end component, e.g., a client device, such as the mobile device **102**, having a graphical user interface or a Web browser through which a user can interact with an implementation of the invention, or any combination of such back-end, middleware, or front-end components. The components of the system can be interconnected by any form or medium of digital data communication, e.g., a communication network.

A number of implementations have been described. Nevertheless, it will be understood that various modifications may be made without departing from the spirit and scope of the disclosure. For example, steps of the present disclosure can be performed in a different order and still achieve desirable results. Accordingly, other implementations are within the scope of the following claims.

The invention claimed is:

1. A computer-implemented method for providing a user of a mobile device access to patient information and patient physiological data, the method being executed by one or more processors and comprising:

receiving, by the one or more processors, first user input, the first user input indicating a user command to display a timeline screen;

in response to receiving the first user input, determining, by a data management system executed by the one or more processors, that portions of the user command are associated with patient data stored in a plurality of data stores associated with a plurality of facility systems of a healthcare continuum, each data store in the plurality of data stores being associated with a respective facility system of the plurality of facility systems and being, accessed through a user-facility index that maps an identifier associated with the user to two or more facilities, in a plurality of facilities, that the user is associated with as a healthcare provider to determine a plurality of medical events to be graphically depicted, the plurality of medical events being specific to a patient, the data management system comprising a data cache module configured to selectively operate in a pass-through mode and a reposed mode to improve performance of retrieval of the patient data, the pass-through mode enabling real-time mode retrieval of the patient data from a plurality of facility systems by using data identifiers and passing the patient data onward for responding to the user command;

displaying the timeline screen on a touch-screen display of the mobile device in a user-customized view, the timeline screen displaying a first time period of a timeline associated with the patient and comprising at least a first portion of the plurality of medical events, each medical event comprising summary information, the plurality of medical events being graphically depicted in chronological order, such that an amount of detail of the summary information and a size of each of

the first portion of the plurality of medical events are adjusted based on the first time period of the timeline and a first number of the plurality of medical events being displayed;

receiving, by the one or more processors, second user input, the second user input being input to the timeline displayed on the touch-screen display and indicating a second time period of the timeline based on user contact with the touch-screen display, such that the second time period of the timeline is different than the first time period of the timeline;

in response to receiving the second user input, displaying, by the one or more processors, the timeline screen on the mobile device in the user-customized view, the timeline screen displaying the second time period of the timeline associated with the patient and comprising at least a second portion of the plurality of medical events, such that the amount of detail of the summary information and the size of each of the second portion of the plurality of medical events are adjusted based on the second time period of the timeline and a second number of the plurality of medical events being displayed;

further comprising receiving third user input, the third user input indicating user selection of a category icon; and

in response to receiving the third user input, filtering the timeline to comprise a sub-set of the plurality of medical events, medical events in the sub-set corresponding to a category associated with the category icon.

2. The method of claim **1**, wherein each medical event corresponds to an event category of a plurality of event categories.

3. The method of claim **1**, further comprising receiving patient data and/or patient information from an electronic medical record (EMR) associated with the patient, the summary information comprising at least a portion of the patient data and/or patient information.

4. The method of claim **1**, further comprising determining the chronological order based on timestamp information associated with each of the one or more events.

5. The method of claim **1**, further comprising: receiving user input associated with a medical event; and in response to the user input, displaying detailed medical event information.

6. The method of claim **5**, wherein displaying detailed medical event information comprises displaying an event screen in place of the timeline screen.

7. The method of claim **1**, further comprising: receiving user input; and in response to the user input, scrolling the timeline in the timeline screen to display another portion of the plurality of medical events.

8. The method of claim **1**, further comprising: receiving user input; and in response to the user input, zooming the timeline in the timeline screen to display another portion of the plurality of medical events.

9. The method of claim **1**, wherein at least one medical event of the one or more medical event comprises an icon, the icon graphically depicting an event category associated with the at least one medical event.

10. The method of claim **9**, wherein the icon comprises a generic icon that is provided for all medical events of the same event category.

11. The method of claim **9**, wherein the icon comprises an event-specific icon that is specific to a sub-category associated with the at least one medical event.

29

12. The method of claim 1, further comprising: receiving user input specific to a medical event; and in response to the user input, manipulating summary information provided in the medical event.

13. The method of claim 12, wherein manipulating summary information provided in the medical event, comprises scrolling the manipulating summary information provided in the medical event.

14. The method of claim 12, wherein the summary information provided in the medical event comprises a waveform, and manipulating comprises scrolling the waveform.

15. The method of claim 12, wherein the summary information provided in the medical event comprises a plurality of thumbnail images, and manipulating comprises scrolling between images of the plurality of thumbnail images.

16. A non-transitory computer-readable storage device coupled to one or more processors and having instructions stored thereon which, when executed by the one or more processors, cause the one or more processors to perform operations comprising:

receiving first user input, the first user input indicating a user command to display a timeline screen;

in response to receiving the first user input, determining, by a data management system executed by the one or more processors, that portions of the user command are associated with patient data stored in a plurality of data stores associated with a plurality of facility systems of a healthcare continuum, each data store in the plurality of data stores being associated with a respective facility system of the plurality of facility systems and being accessed through a user-facility index that maps an identifier associated with the user to two or more facilities, in a plurality of facilities, that the user is associated with as a healthcare provider to determine a plurality of medical events to be graphically depicted, the plurality of medical events being specific to a patient, the data management system comprising a data cache module configured to selectively operate in a pass-through mode and a reposed mode to improve performance of retrieval of the patient data, the pass-through mode enabling real-time mode retrieval of the patient data from a plurality of facility systems by using data identifiers and passing the patient data onward for responding to the user command;

displaying the timeline screen on a touch-screen display of the mobile device in a user-customized view, the timeline screen displaying a first time period of a timeline associated with the patient and comprising at least a first portion of the plurality of medical events, each medical event comprising summary information, the plurality of medical events being graphically depicted in chronological order, such that an amount of detail of the summary information and a size of each of the first portion of the plurality of medical events are adjusted based on the first time period of the timeline and a first number of the plurality of medical events being displayed;

receiving second user input, the second user input being input to the timeline displayed on the touch-screen display and indicating a second time period of the timeline based on user contact with the touch-screen display, such that the second time period of the timeline is different than the first time period of the timeline;

in response to receiving the second user input, displaying the timeline screen on the mobile device in the user-

30

customized view, the timeline screen displaying the second time period of the timeline associated with the patient and comprising at least a second portion of the plurality of medical events, such that the amount of detail of the summary information and the size of each of the second portion of the plurality of medical events are adjusted based on the second time period of the timeline and a second number of the plurality of medical events being displayed;

further comprising receiving third user input, the third user input indicating user selection of a category icon; and

in response to receiving the third user input, filtering the timeline to comprise a sub-set of the plurality of medical events, medical events in the sub-set corresponding to a category associated with the category icon.

17. A system, comprising:

one or more processors; and

a computer-readable storage medium in communication with the one or more processors and having instructions stored thereon which, when executed by the one or more processors, cause the one or more processors to perform operations comprising:

receiving first user input, the first user input indicating a user command to display a timeline screen;

in response to receiving the first user input, determining, by a data management system executed by the one or more processors, that portions of the user command are associated with patient data stored in a plurality of data stores associated with a plurality of facility systems of a healthcare continuum, each data store in the plurality of data stores being associated with a respective facility system of the plurality of facility systems and being accessed through a user-facility index that maps an identifier associated with the user to two or more facilities, in a plurality of facilities, that the user is associated with as a healthcare provider to determine a plurality of medical events to be graphically depicted, the plurality of medical events being specific to a patient, the data management system comprising a data cache module configured to selectively operate in a pass-through mode and a reposed mode to improve performance of retrieval of the patient data, the pass-through mode enabling real-time mode retrieval of the patient data from a plurality of facility systems by using data identifiers and passing the patient data onward for responding to the user command;

displaying the timeline screen on a touch-screen display of the mobile device in a user-customized view, the timeline screen displaying a first time period of a timeline associated with the patient and comprising at least a first portion of the plurality of medical events, each medical event comprising summary information, the plurality of medical events being graphically depicted in chronological order, such that an amount of detail of the summary information and a size of each of the first portion of the plurality of medical events are adjusted based on the first time period of the timeline and a first number of the plurality of medical events being displayed;

receiving second user input, the second user input being input to the timeline displayed on the touch-screen display and indicating a second time period of the timeline based on user contact with the touch-screen display, such that the second time period of the timeline is different than the first time period of the timeline;

in response to receiving the second user input, displaying
the timeline screen on the mobile device in the user-
customized view, the timeline screen displaying the
second time period of the timeline associated with the
patient and comprising at least a second portion of the 5
plurality of medical events, such that the amount of
detail of the summary information and the size of each
of the second portion of the plurality of medical events
are adjusted based on the second time period of the
timeline and a second number of the plurality of 10
medical events being displayed;
further comprising receiving third user input, the third
user input indicating user selection of a category icon;
and
in response to receiving the third user input, filtering the 15
timeline to comprise a sub-set of the plurality of
medical events, medical events in the sub-set corre-
sponding to a category associated with the category
icon.

* * * * *