



(12) **United States Patent**  
**Grube et al.**

(10) **Patent No.:** **US 10,402,268 B2**  
(45) **Date of Patent:** **\*Sep. 3, 2019**

(54) **UTILIZING A DISPERSED STORAGE NETWORK ACCESS TOKEN MODULE TO ACQUIRE DIGITAL CONTENT FROM A DIGITAL CONTENT PROVIDER**

(75) Inventors: **Gary W. Grube**, Barrington Hills, IL (US); **Timothy W. Markison**, Mesa, AZ (US); **Greg Dhuse**, Chicago, IL (US); **Jason K. Resch**, Chicago, IL (US); **Ilya Volvovski**, Chicago, IL (US); **Wesley Leggette**, Oak Park, IL (US)

(73) Assignee: **PURE STORAGE, INC.**, Mountain View, CA (US)

(\*) Notice: Subject to any disclaimer, the term of this patent is extended or adjusted under 35 U.S.C. 154(b) by 1034 days.

This patent is subject to a terminal disclaimer.

(21) Appl. No.: **13/347,334**

(22) Filed: **Jan. 10, 2012**

(65) **Prior Publication Data**  
US 2012/0198066 A1 Aug. 2, 2012

**Related U.S. Application Data**

(60) Provisional application No. 61/438,490, filed on Feb. 1, 2011.

(51) **Int. Cl.**  
**G06F 11/10** (2006.01)  
**G06F 11/14** (2006.01)  
(Continued)

(52) **U.S. Cl.**  
CPC ..... **G06F 11/1076** (2013.01); **G06F 3/06** (2013.01); **G06F 3/0604** (2013.01); **G06F 3/067** (2013.01);  
(Continued)

(58) **Field of Classification Search**  
CPC .. H04L 67/1097; H04L 65/4084; H04L 65/50  
(Continued)

(56) **References Cited**  
U.S. PATENT DOCUMENTS

4,092,732 A 5/1978 Ouchi  
5,454,101 A 9/1995 Mackay et al.  
(Continued)

**OTHER PUBLICATIONS**

Kubiatowicz, et al.; OceanStore: An Architecture for Global-Scale Persistent Storage; Proceedings of the Ninth International Conference on Architectural Support for Programming Languages and Operating Systems (ASPLOS 2000); Nov. 2000; pp. 1-12.  
(Continued)

*Primary Examiner* — Backhean Tiv  
*Assistant Examiner* — Joseph M Cousins  
(74) *Attorney, Agent, or Firm* — Garlick & Markison; Kelly H. Hale

(57) **ABSTRACT**

A method begins with a computing device receiving a request to acquire digital content from a digital content provider and forwarding the request to a dispersed storage network (DSN) pre-paid module. The method continues with the DSN pre-paid module validating the request, generating a plurality of sets of at least a threshold number of digital content read requests, and sending the plurality of sets of the at least a threshold number of digital content read requests to the digital content provider via the computing device when the request to acquire the digital content is validated. The method continues with at least one of the DSN pre-paid module and the computing device receiving a plurality of sets of at least a decoded threshold number of encoded data slices and decoding the plurality of sets of the at least a decoded threshold number of encoded data slices to produce the digital content.

**9 Claims, 21 Drawing Sheets**

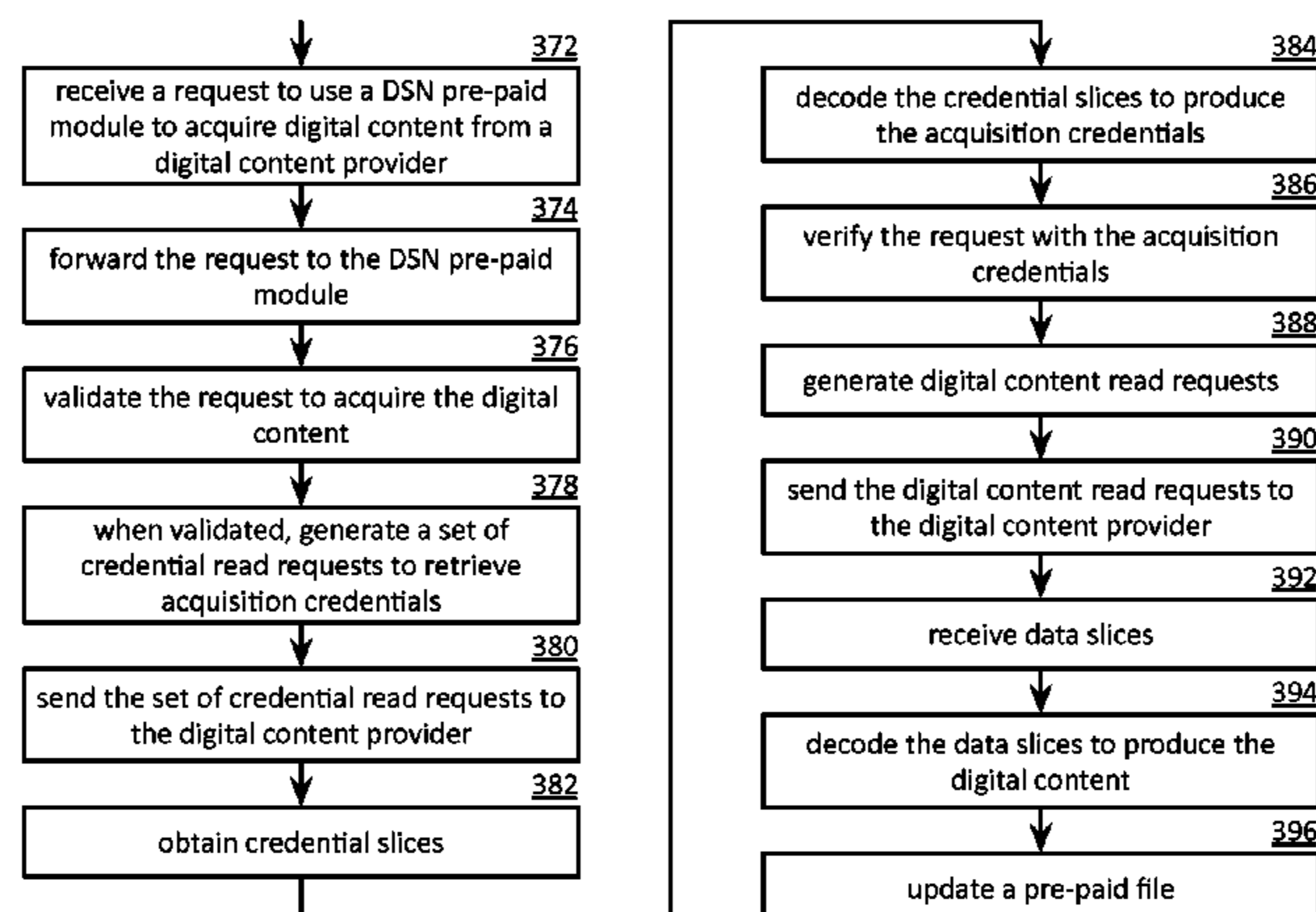

- (51) **Int. Cl.**  
**G06F 3/06** (2006.01)  
**G06F 15/173** (2006.01)  
**G06F 21/80** (2013.01)  
**H04L 29/08** (2006.01)  
**H04L 9/08** (2006.01)
- (52) **U.S. Cl.**  
 CPC ..... **G06F 3/0619** (2013.01); **G06F 11/1008**  
 (2013.01); **G06F 11/1402** (2013.01); **G06F**  
**11/1448** (2013.01); **G06F 15/17331** (2013.01);  
**H04L 9/085** (2013.01); **H04L 67/1097**  
 (2013.01); **G06F 3/0665** (2013.01); **G06F**  
**11/1446** (2013.01); **G06F 21/805** (2013.01)
- (58) **Field of Classification Search**  
 USPC ..... 709/225  
 See application file for complete search history.

(56) **References Cited**  
 U.S. PATENT DOCUMENTS

5,485,474	A	1/1996	Rabin	
5,774,643	A	6/1998	Lubbers et al.	
5,802,364	A	9/1998	Senator et al.	
5,809,285	A	9/1998	Hilland	
5,890,156	A	3/1999	Rekieta et al.	
5,987,622	A	11/1999	Lo Verso et al.	
5,991,414	A	11/1999	Garay et al.	
6,012,159	A	1/2000	Fischer et al.	
6,058,454	A	5/2000	Gerlach et al.	
6,128,277	A	5/2000	Bruck et al.	
6,175,571	B1	1/2001	Haddock et al.	
6,192,472	B1 *	2/2001	Garay et al. ....	713/165
6,256,688	B1	7/2001	Suetaka et al.	
6,272,658	B1	8/2001	Steele et al.	
6,301,604	B1	10/2001	Nojima	
6,356,949	B1	3/2002	Katsandres et al.	
6,366,995	B1	4/2002	Vilkov et al.	
6,374,336	B1	4/2002	Peters et al.	
6,415,373	B1	7/2002	Peters et al.	
6,418,539	B1	7/2002	Walker	
6,449,688	B1	9/2002	Peters et al.	
6,567,948	B2	5/2003	Steele et al.	
6,571,282	B1	5/2003	Bowman-Amuah	
6,609,223	B1	8/2003	Wolfgang	
6,631,449	B1	10/2003	Borril	
6,718,361	B1	4/2004	Basani et al.	
6,760,808	B2	7/2004	Peters et al.	
6,785,768	B2	8/2004	Peters et al.	
6,785,783	B2	8/2004	Buckland	
6,826,711	B2	11/2004	Moulton et al.	
6,879,596	B1	4/2005	Dooply	
7,003,688	B1	2/2006	Pittelkow et al.	
7,024,451	B2	4/2006	Jorgenson	
7,024,609	B2	4/2006	Wolfgang et al.	
7,080,101	B1	7/2006	Watson et al.	
7,103,824	B2	9/2006	Halford	
7,103,915	B2	9/2006	Redlich et al.	
7,111,115	B2	9/2006	Peters et al.	
7,140,044	B2	11/2006	Redlich et al.	
7,146,644	B2	12/2006	Redlich et al.	
7,171,493	B2	1/2007	Shu et al.	
7,222,133	B1	5/2007	Raipurkar et al.	
7,240,236	B2	7/2007	Cutts et al.	
7,272,613	B2	9/2007	Sim et al.	
7,376,805	B2	5/2008	Stroberger et al.	
7,636,724	B2	12/2009	de la Torre et al.	
2002/0062422	A1	5/2002	Butterworth et al.	
2002/0166079	A1	11/2002	Ulrich et al.	
2003/0018927	A1	1/2003	Gadir et al.	
2003/0037261	A1	2/2003	Meffert et al.	
2003/0065617	A1	4/2003	Watkins et al.	
2003/0084020	A1	5/2003	Shu	
2004/0024963	A1	2/2004	Talagala et al.	
2004/0122917	A1	6/2004	Menon et al.	

2004/0215998	A1	10/2004	Buxton et al.	
2004/0228493	A1	11/2004	Ma et al.	
2005/0100022	A1	5/2005	Ramprashad	
2005/0114594	A1	5/2005	Corbett et al.	
2005/0125593	A1	6/2005	Karpoff et al.	
2005/0131993	A1	6/2005	Fatula, Jr.	
2005/0132070	A1	6/2005	Redlich et al.	
2005/0144382	A1	6/2005	Schmisser	
2005/0216813	A1	9/2005	Cutts et al.	
2005/0229069	A1	10/2005	Hassner	
2005/0246393	A1	11/2005	Coates et al.	
2005/0273686	A1	12/2005	Turner et al.	
2006/0047907	A1	3/2006	Shiga et al.	
2006/0136448	A1	6/2006	Cialini et al.	
2006/0156059	A1	7/2006	Kitamura	
2006/0224603	A1	10/2006	Correll, Jr.	
2007/0079081	A1	4/2007	Gladwin et al.	
2007/0079082	A1	4/2007	Gladwin et al.	
2007/0079083	A1	4/2007	Gladwin et al.	
2007/0088970	A1	4/2007	Buxton et al.	
2007/0283167	A1	6/2007	Venters, III et al.	
2007/0174192	A1	7/2007	Gladwin et al.	
2007/0214285	A1	9/2007	Au et al.	
2007/0234110	A1	10/2007	Soran et al.	
2009/0094251	A1	4/2009	Gladwin et al.	
2009/0094318	A1	4/2009	Gladwin et al.	
2010/0011061	A1 *	1/2010	Hudson et al. ....	709/204
2010/0023524	A1	1/2010	Gladwin et al.	
2010/0070608	A1 *	3/2010	Hosur .....	709/218
2010/0169463	A1 *	7/2010	Harper .....	709/219
2010/0199089	A1 *	8/2010	Vysogorets et al. ....	713/168
2010/0268692	A1 *	10/2010	Resch .....	G06F 11/1044 707/687
2010/0287200	A1 *	11/2010	Dhuse .....	H04N 7/17336 707/770
2011/0154320	A1 *	6/2011	Verma .....	718/1
2012/0059910	A1 *	3/2012	Cassidy .....	G06F 17/30029 709/219
2012/0151206	A1 *	6/2012	Paris et al. ....	713/155

OTHER PUBLICATIONS

International Search Report and Written Opinion for Application No. PCT/US2012/023311, dated Apr. 5, 2012; 7 pgs.

Shamir; How to Share a Secret; Communications of the ACM; vol. 22, No. 11; Nov. 1979; pp. 612-613.

Rabin; Efficient Dispersal of Information for Security, Load Balancing, and Fault Tolerance; Journal of the Association for Computer Machinery; vol. 36, No. 2; Apr. 1989; pp. 335-348.

Chung; An Automatic Data Segmentation Method for 3D Measured Data Points; National Taiwan University; pp. 1-8; 1998.

Plank, T1: Erasure Codes for Storage Applications; FAST2005, 4th Usenix Conference on File Storage Technologies; Dec. 13-16, 2005; pp. 1-74.

Wildi; Java iSCSi Initiator; Master Thesis; Department of Computer and Information Science, University of Konstanz; Feb. 2007; 60 pgs.

Legg; Lightweight Directory Access Protocol (LDAP): Syntaxes and Matching Rules; IETF Network Working Group; RFC 4517; Jun. 2006; pp. 1-50.

Zeilenga; Lightweight Directory Access Protocol (LDAP): Internationalized String Preparation; IETF Network Working Group; RFC 4518; Jun. 2006; pp. 1-14.

Smith; Lightweight Directory Access Protocol (LDAP): Uniform Resource Locator; IETF Network Working Group; RFC 4516; Jun. 2006; pp. 1-15.

Smith; Lightweight Directory Access Protocol (LDAP): String Representation of Search Filters; IETF Network Working Group; RFC 4515; Jun. 2006; pp. 1-12.

Zeilenga; Lightweight Directory Access Protocol (LDAP): Directory Information Models; IETF Network Working Group; RFC 4512; Jun. 2006; pp. 1-49.

Sciberras; Lightweight Directory Access Protocol (LDAP): Schema for User Applications; IETF Network Working Group; RFC 4519; Jun. 2006; pp. 1-33.

(56)

**References Cited**

OTHER PUBLICATIONS

Harrison; Lightweight Directory Access Protocol (LDAP): Authentication Methods and Security Mechanisms; IETF Network Working Group; RFC 4513; Jun. 2006; pp. 1-32.

Zeilenga; Lightweight Directory Access Protocol (LDAP): Technical Specification Road Map; IETF Network Working Group; RFC 4510; Jun. 2006; pp. 1-8.

Zeilenga; Lightweight Directory Access Protocol (LDAP): String Representation of Distinguished Names; IETF Network Working Group; RFC 4514; Jun. 2006; pp. 1-15.

Sermersheim; Lightweight Directory Access Protocol (LDAP): The Protocol; IETF Network Working Group; RFC 4511; Jun. 2006; pp. 1-68.

Satran, et al.; Internet Small Computer Systems Interface (iSCSI); IETF Network Working Group; RFC 3720; Apr. 2004; pp. 1-257.

Xin, et al.; Evaluation of Distributed Recovery in Large-Scale Storage Systems; 13th IEEE International Symposium on High Performance Distributed Computing; Jun. 2004; pp. 172-181.

Extended European Search Report; EP Application No. 12741687.3; dated Aug. 2, 2017; 7 pgs.

\* cited by examiner

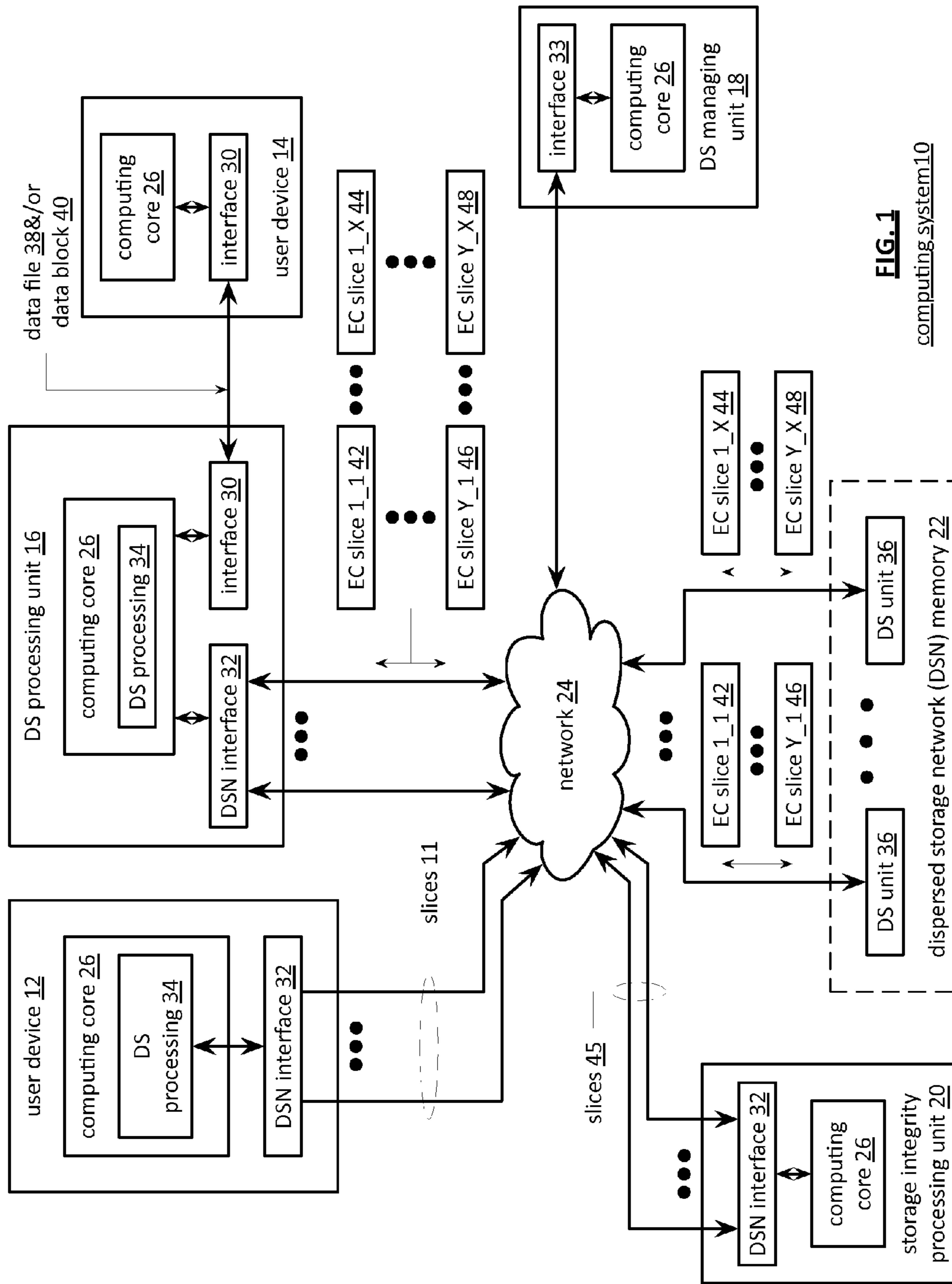

**FIG. 1**  
computing system 10

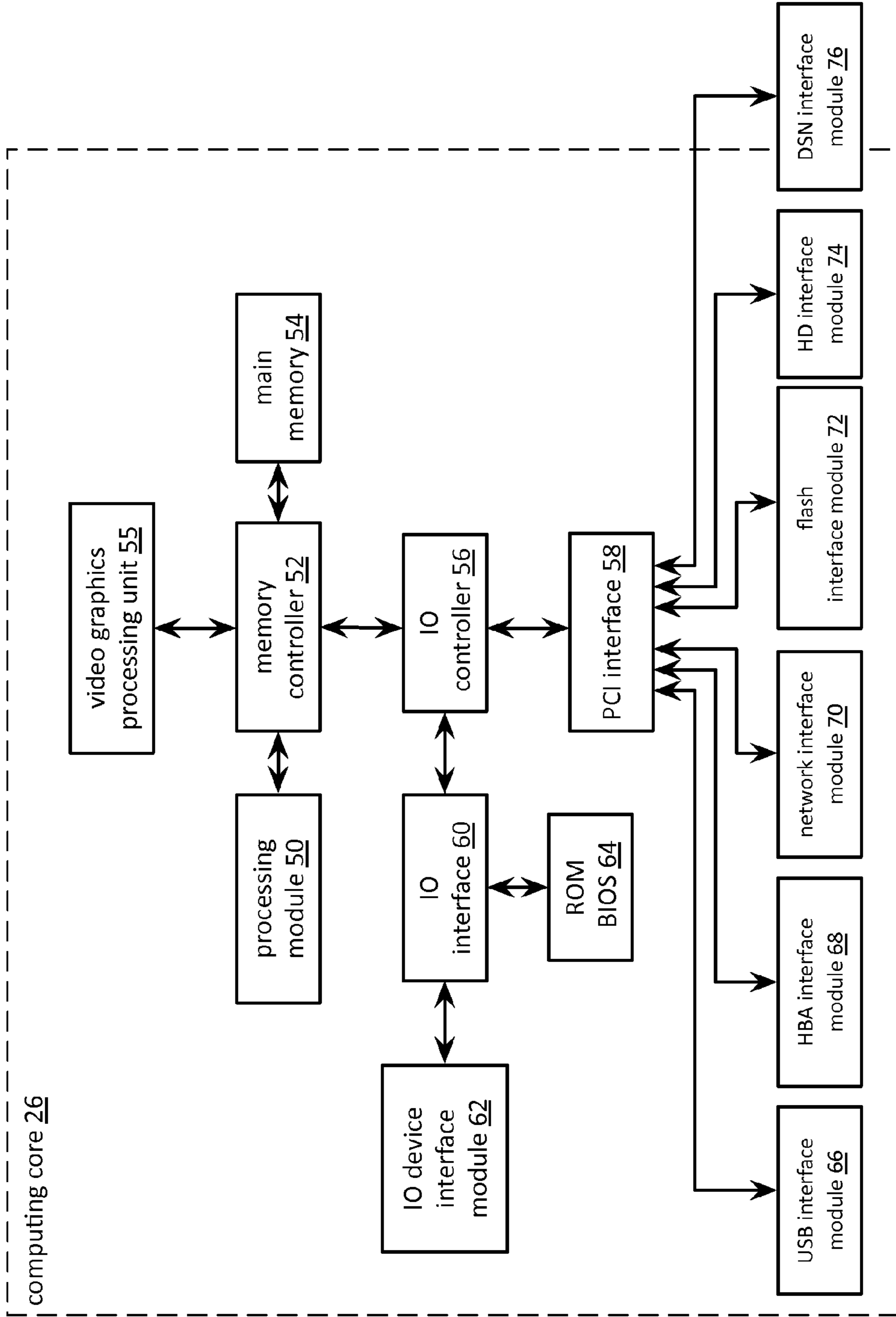

FIG. 2

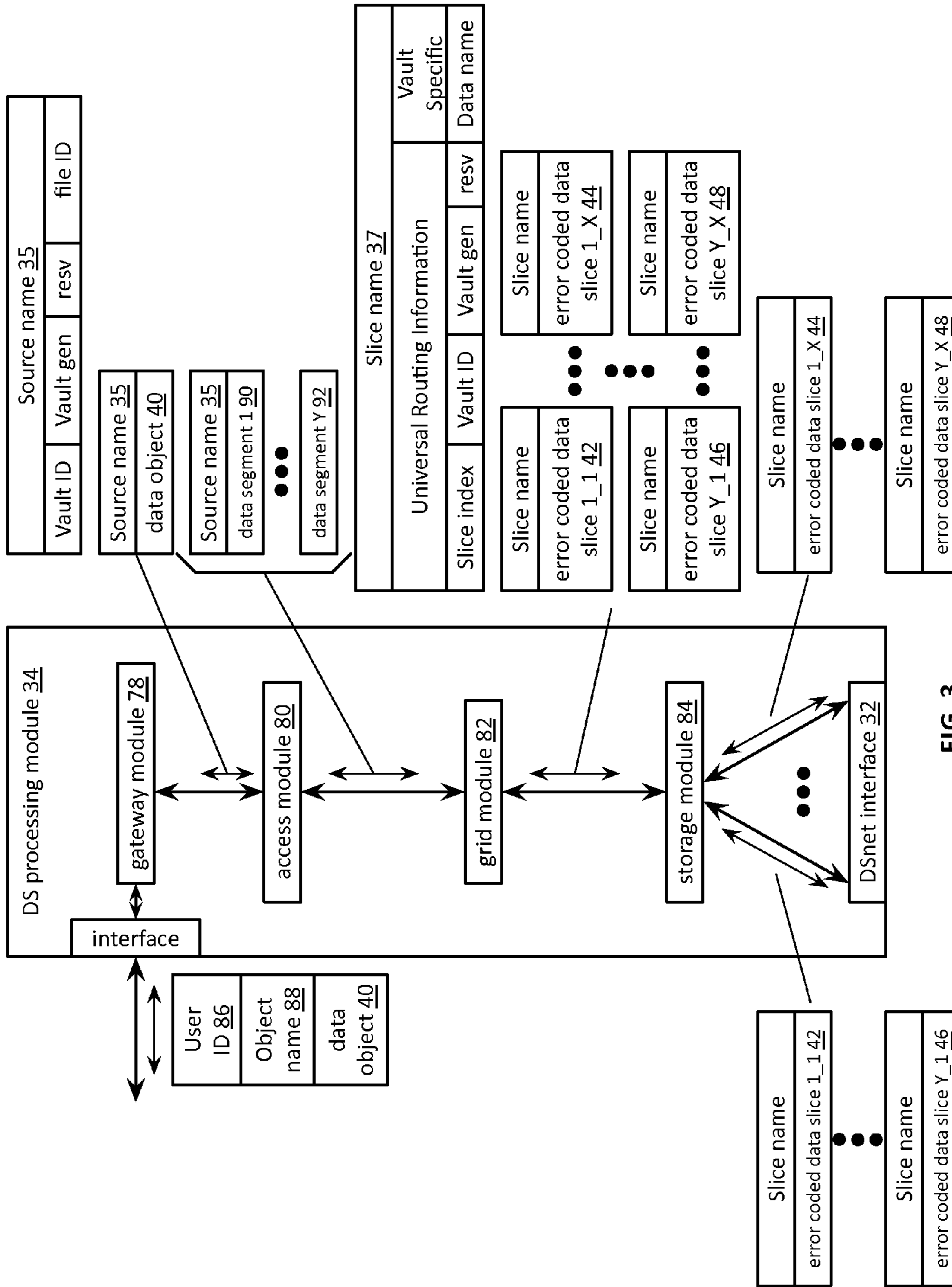

FIG. 3

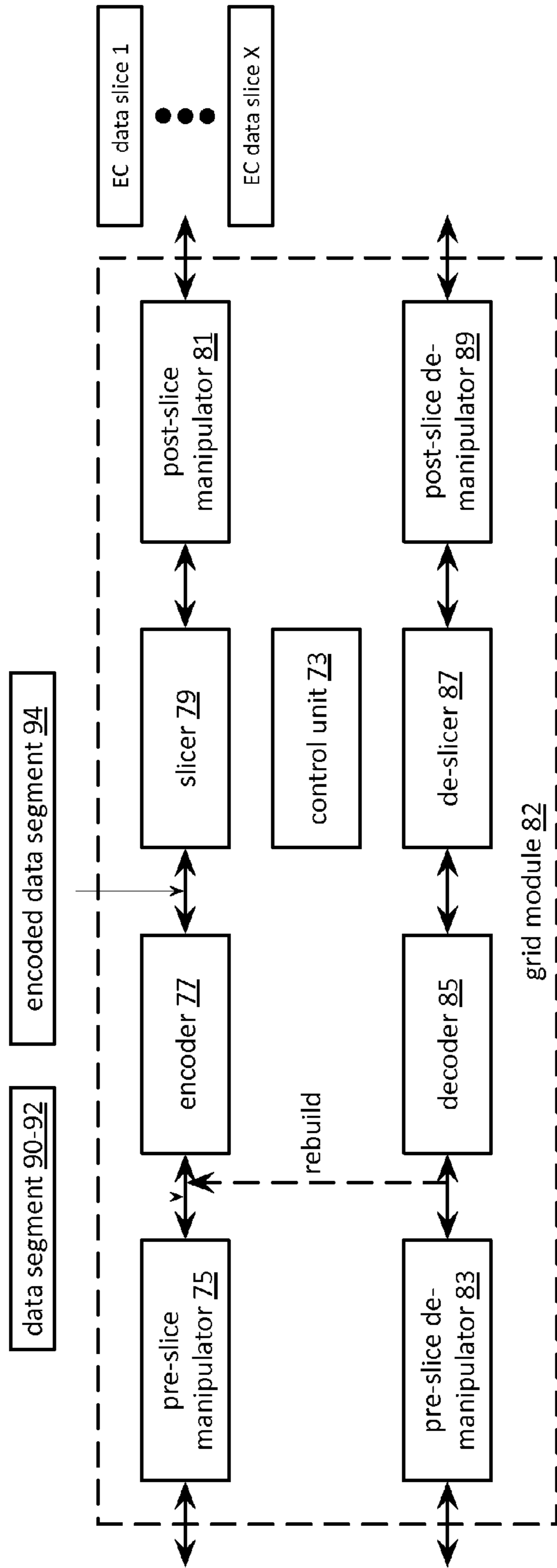

FIG. 4

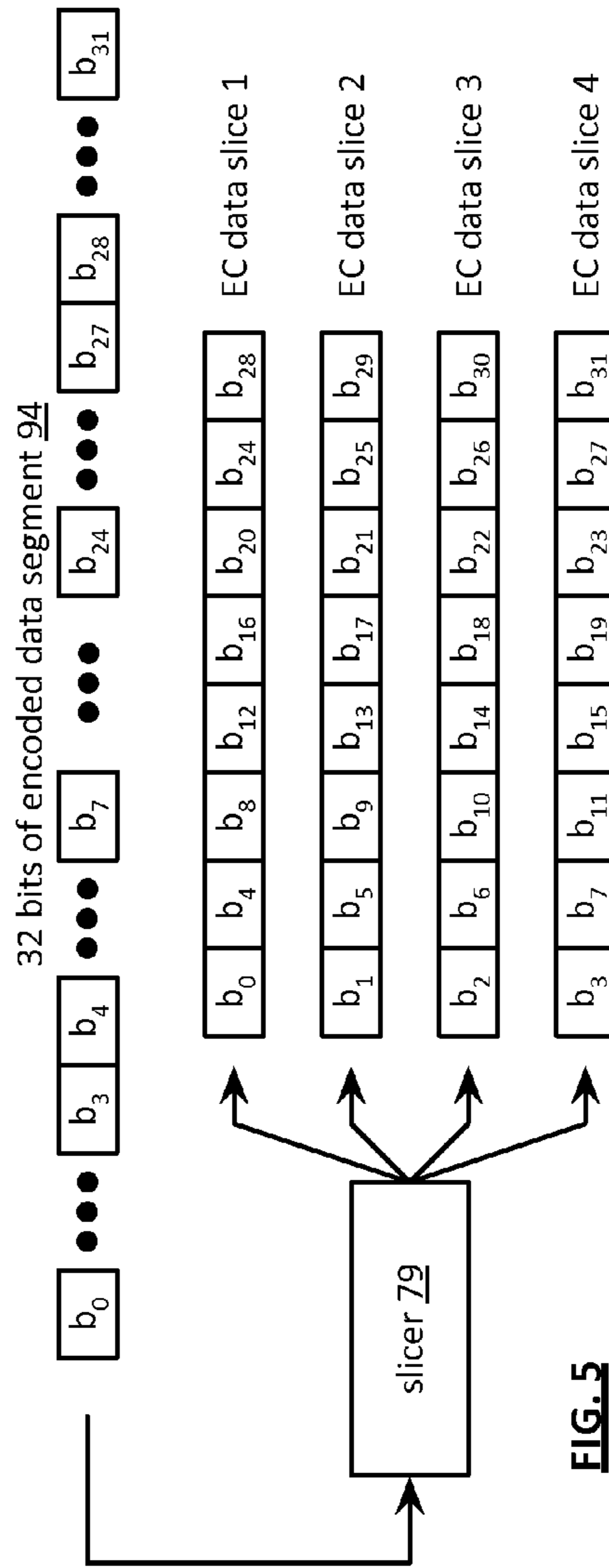

FIG. 5

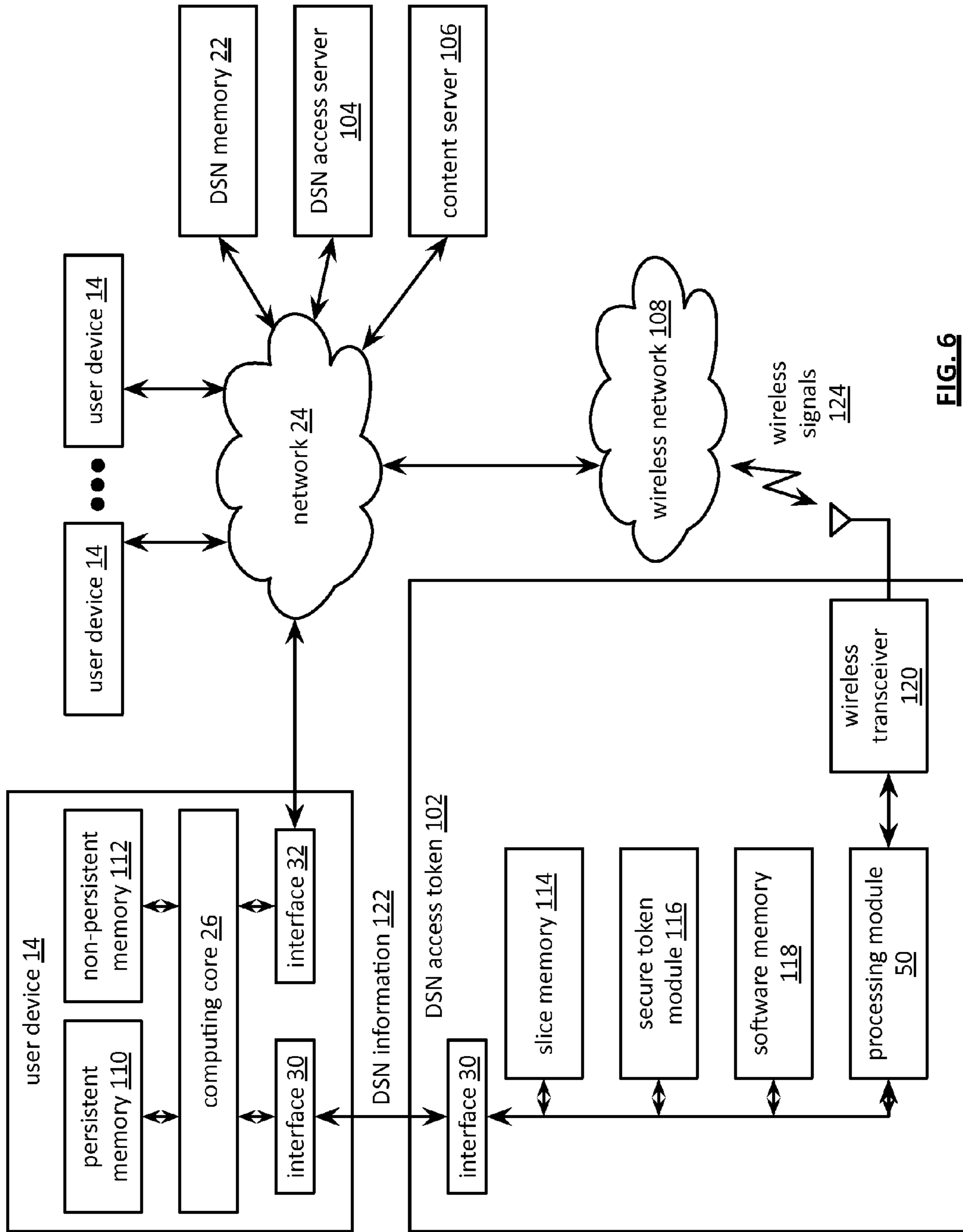
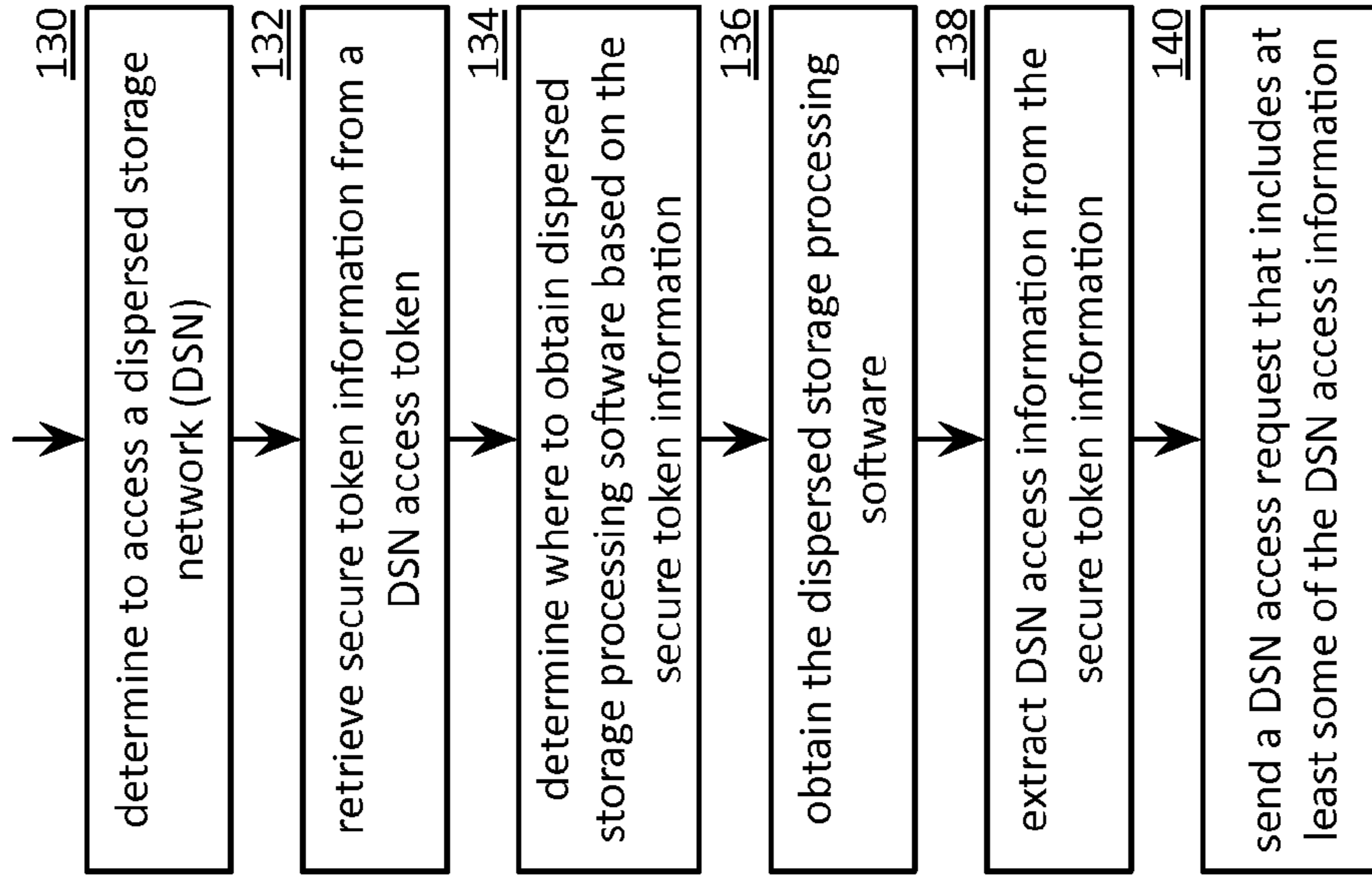

FIG. 6





**FIG. 7**

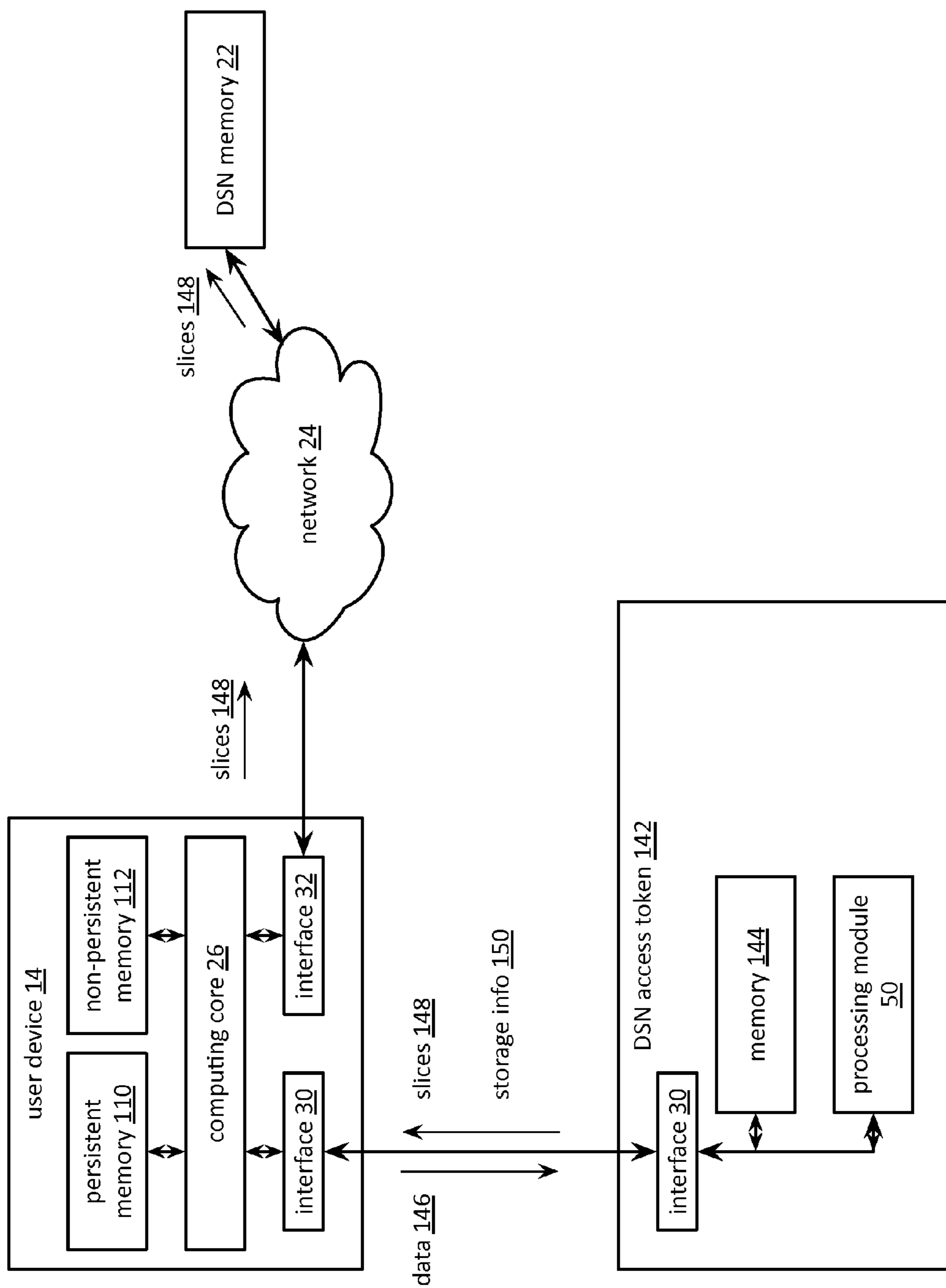

FIG. 8A

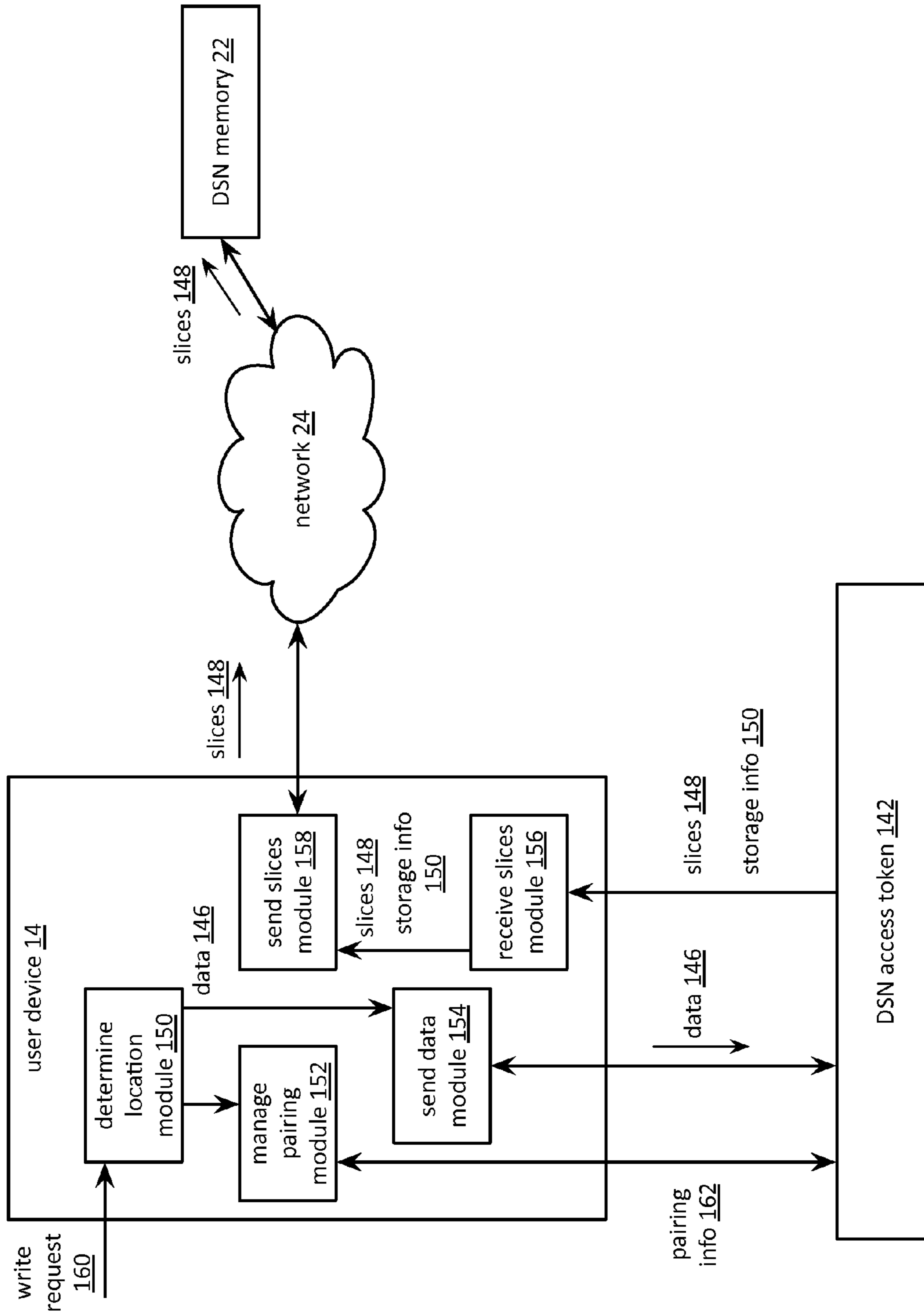
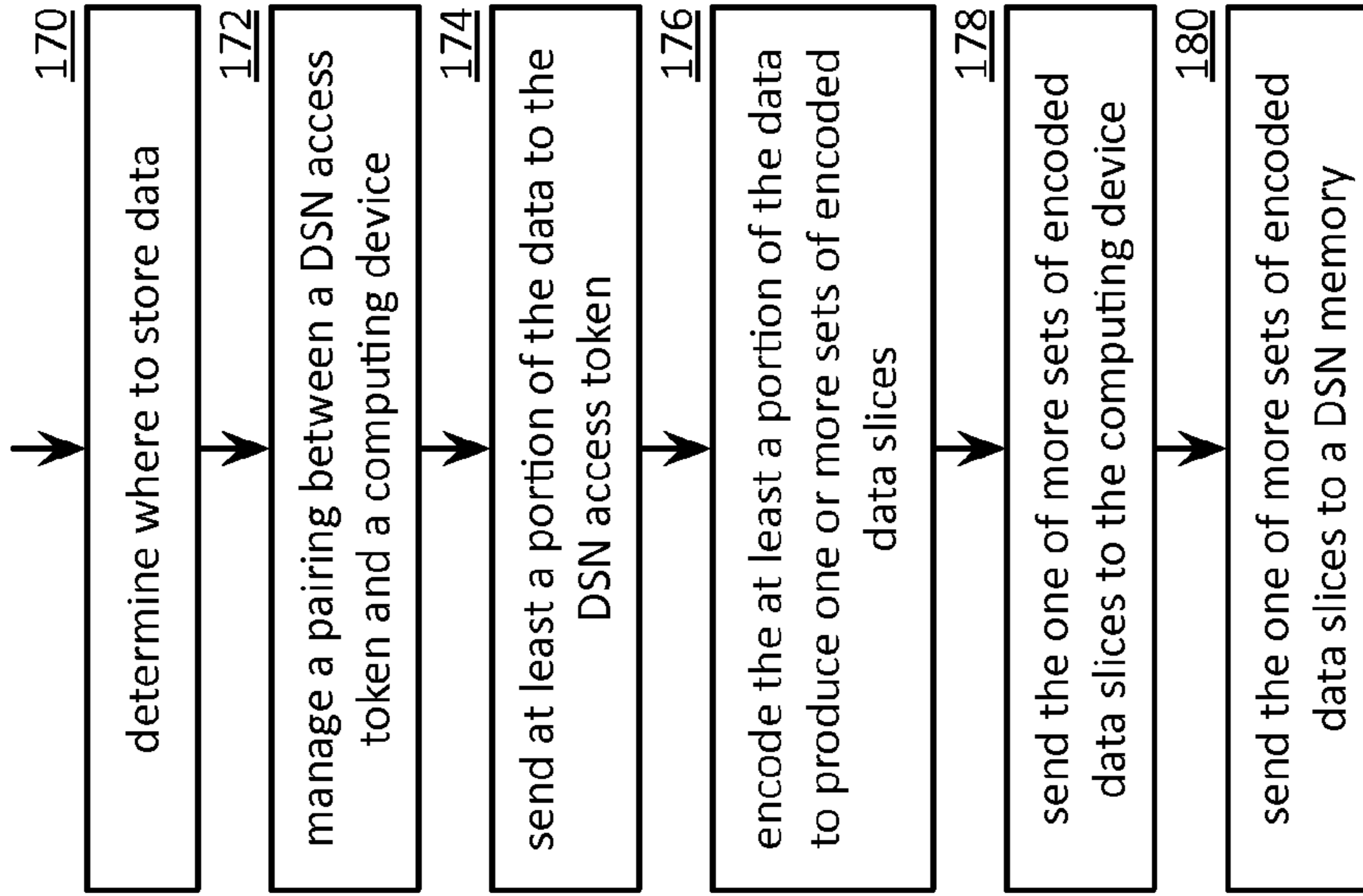

FIG. 8B



**FIG. 8C**

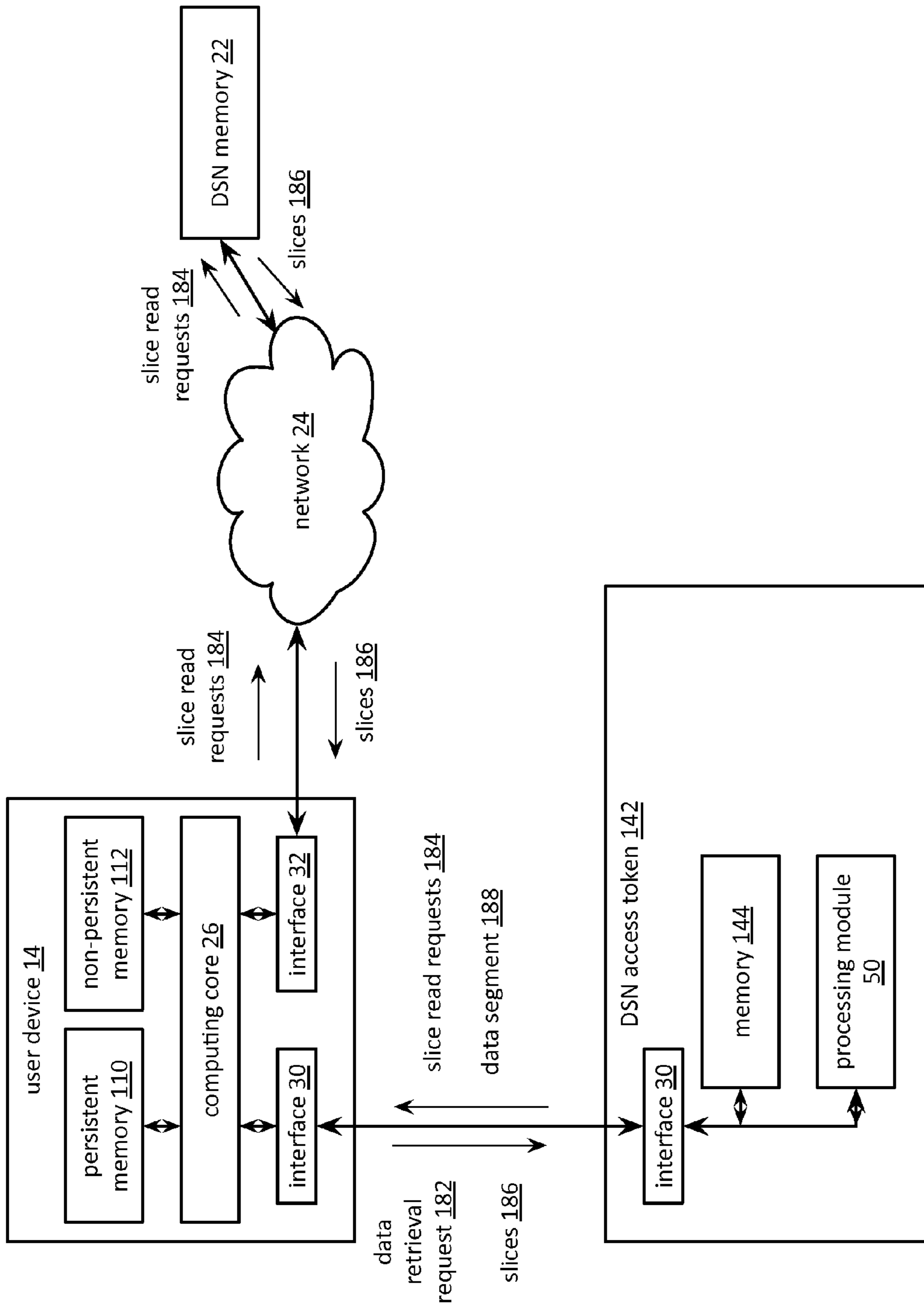

FIG. 9A

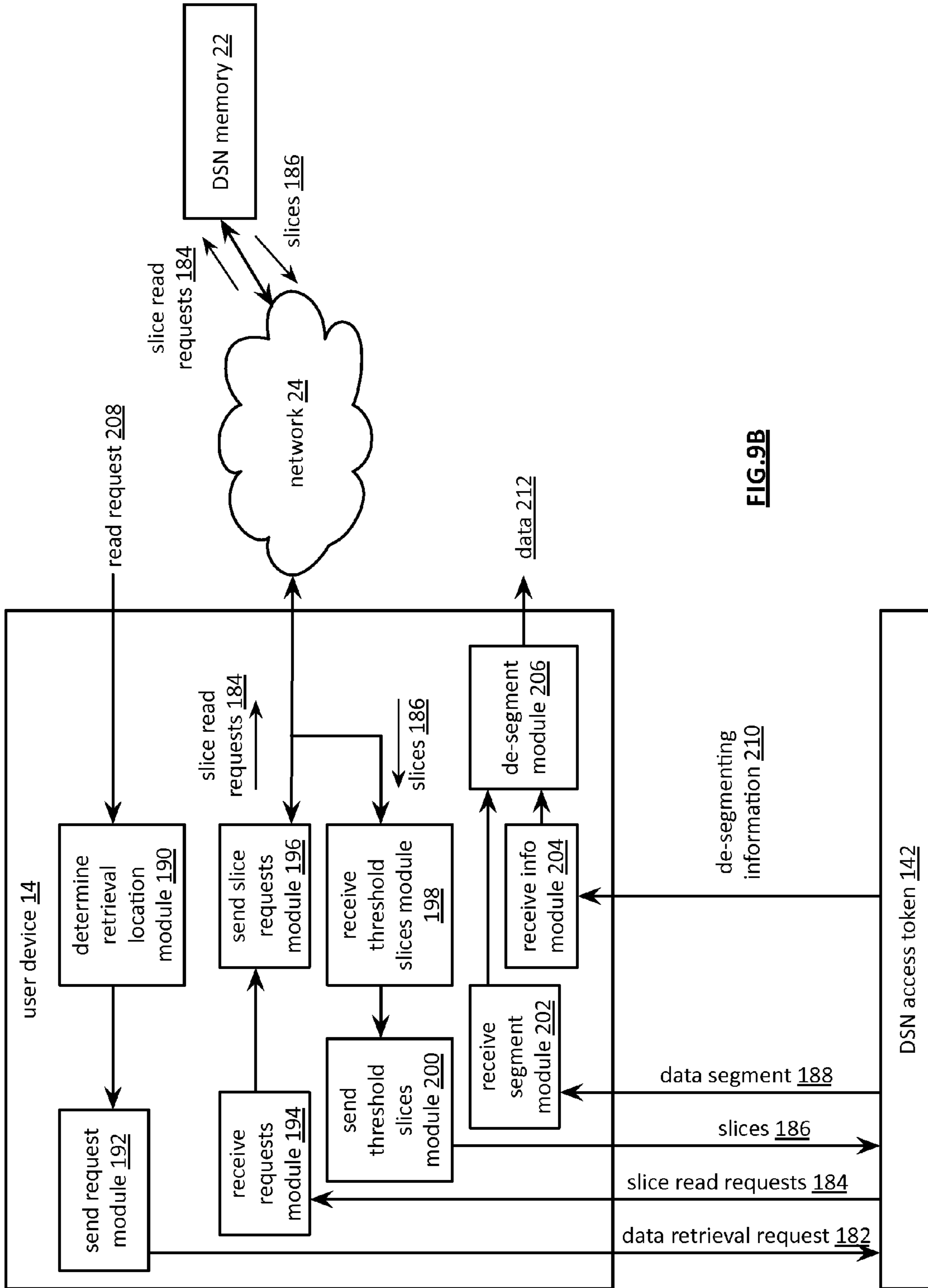
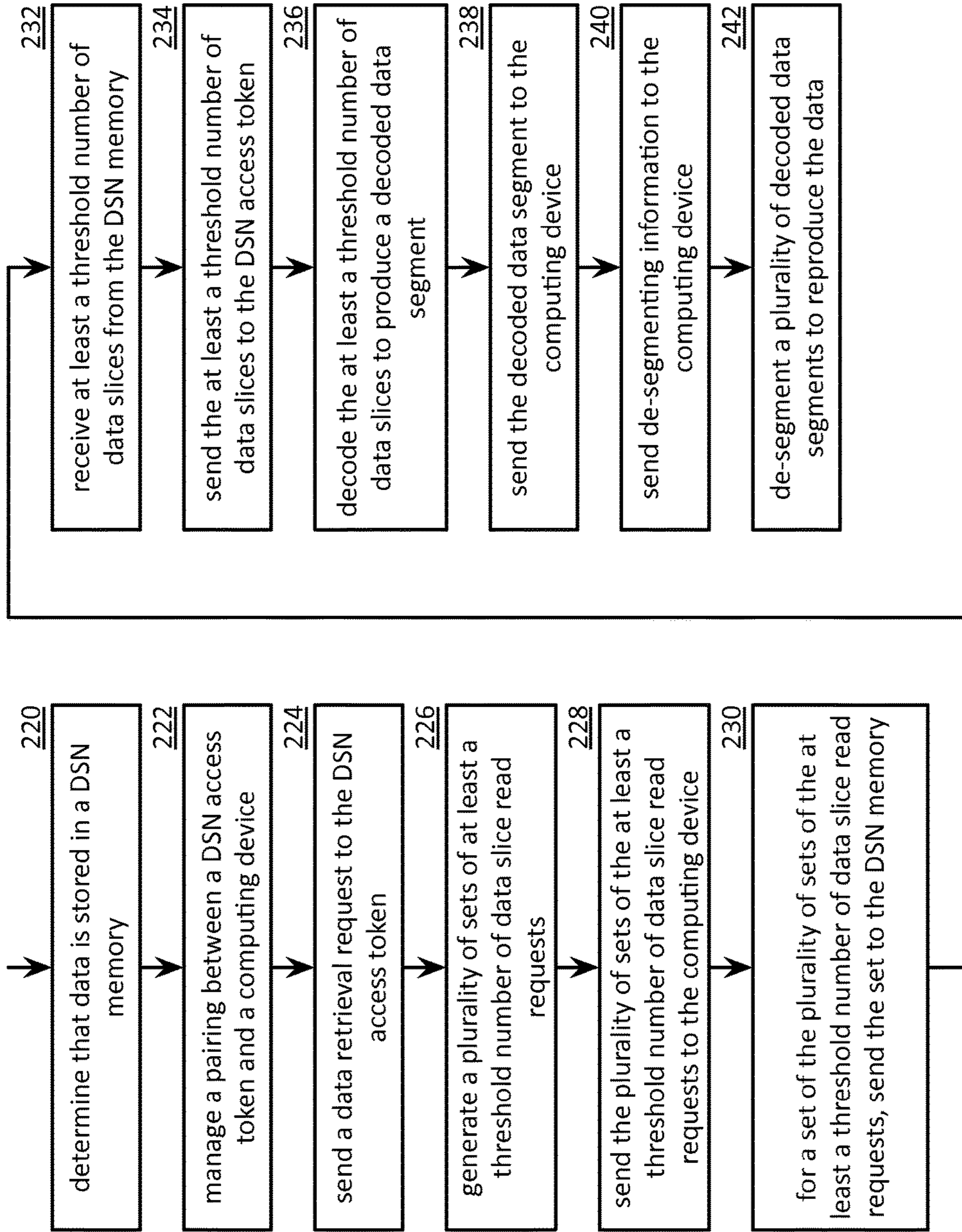
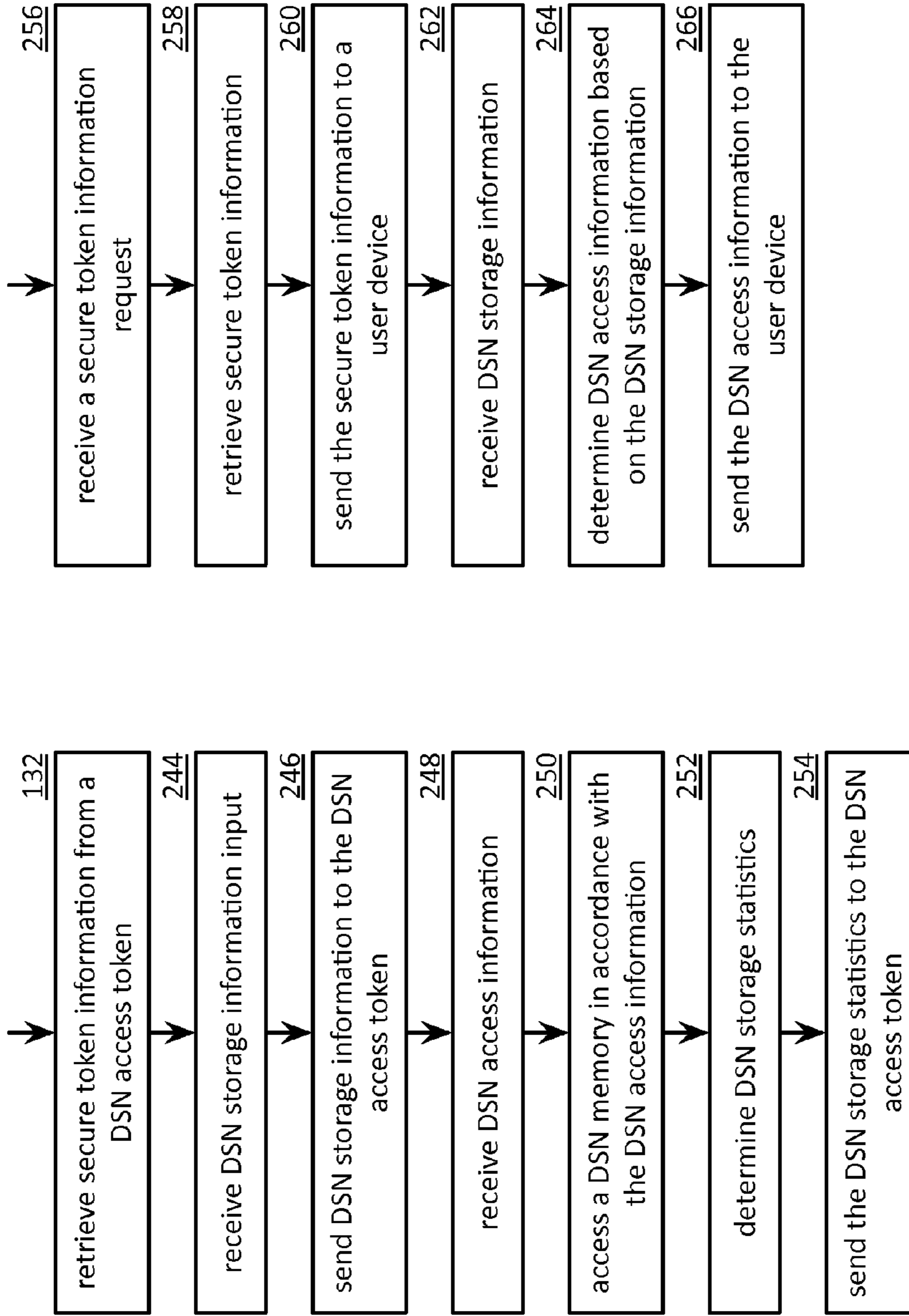

FIG.9B



**FIG. 9C**



**FIG. 10A**

**FIG. 10B**





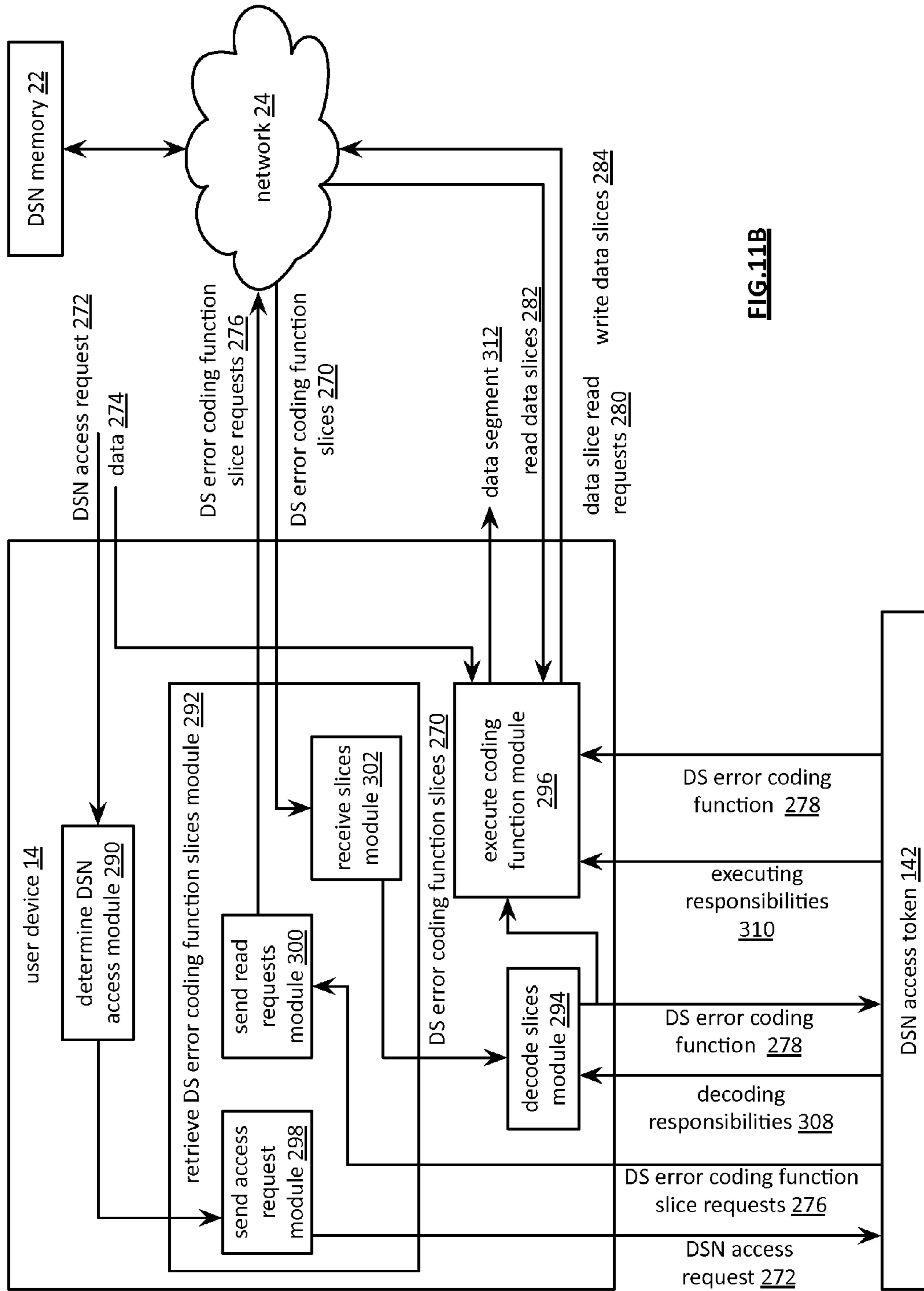

FIG. 11B

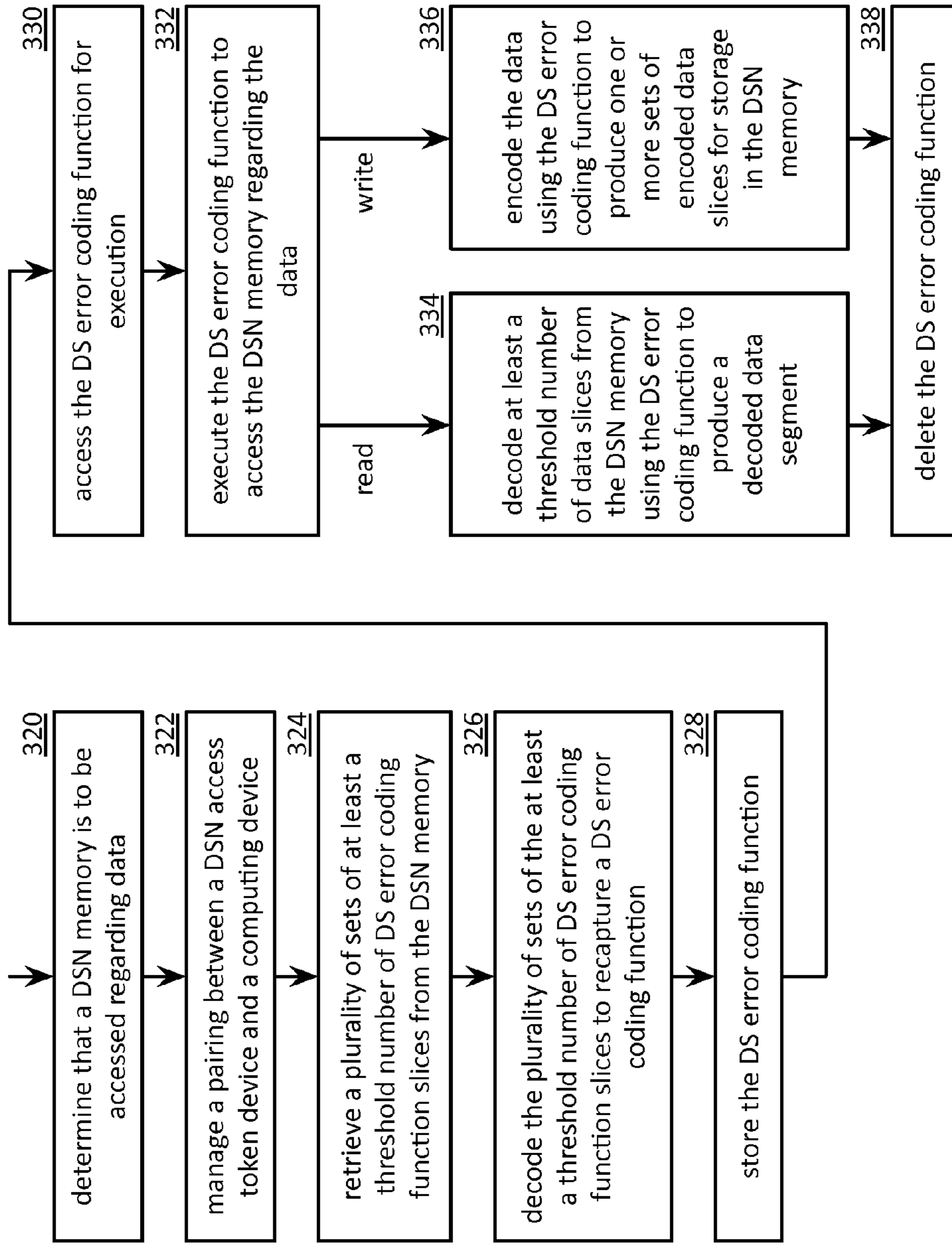
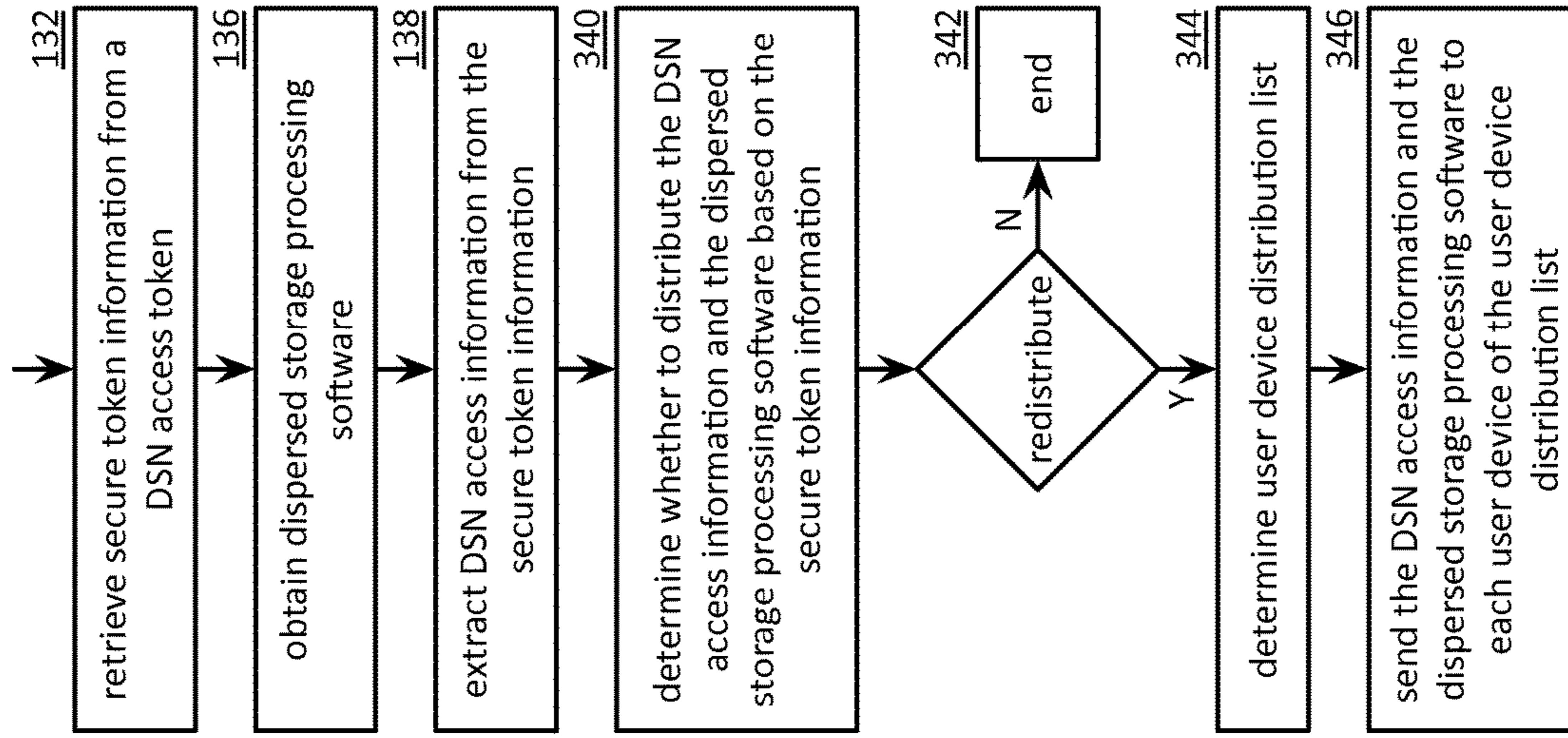

FIG. 11C



**FIG. 12**

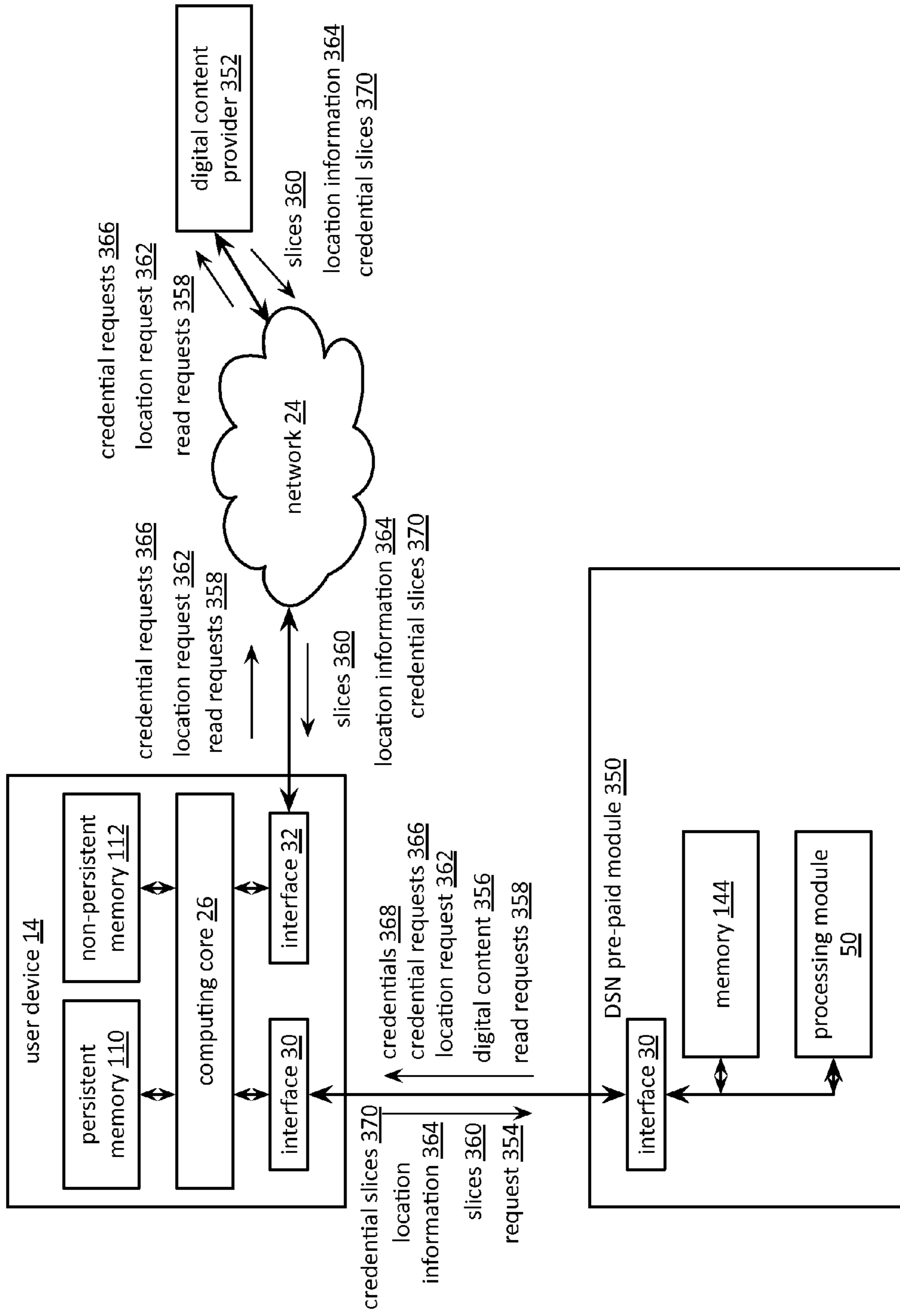
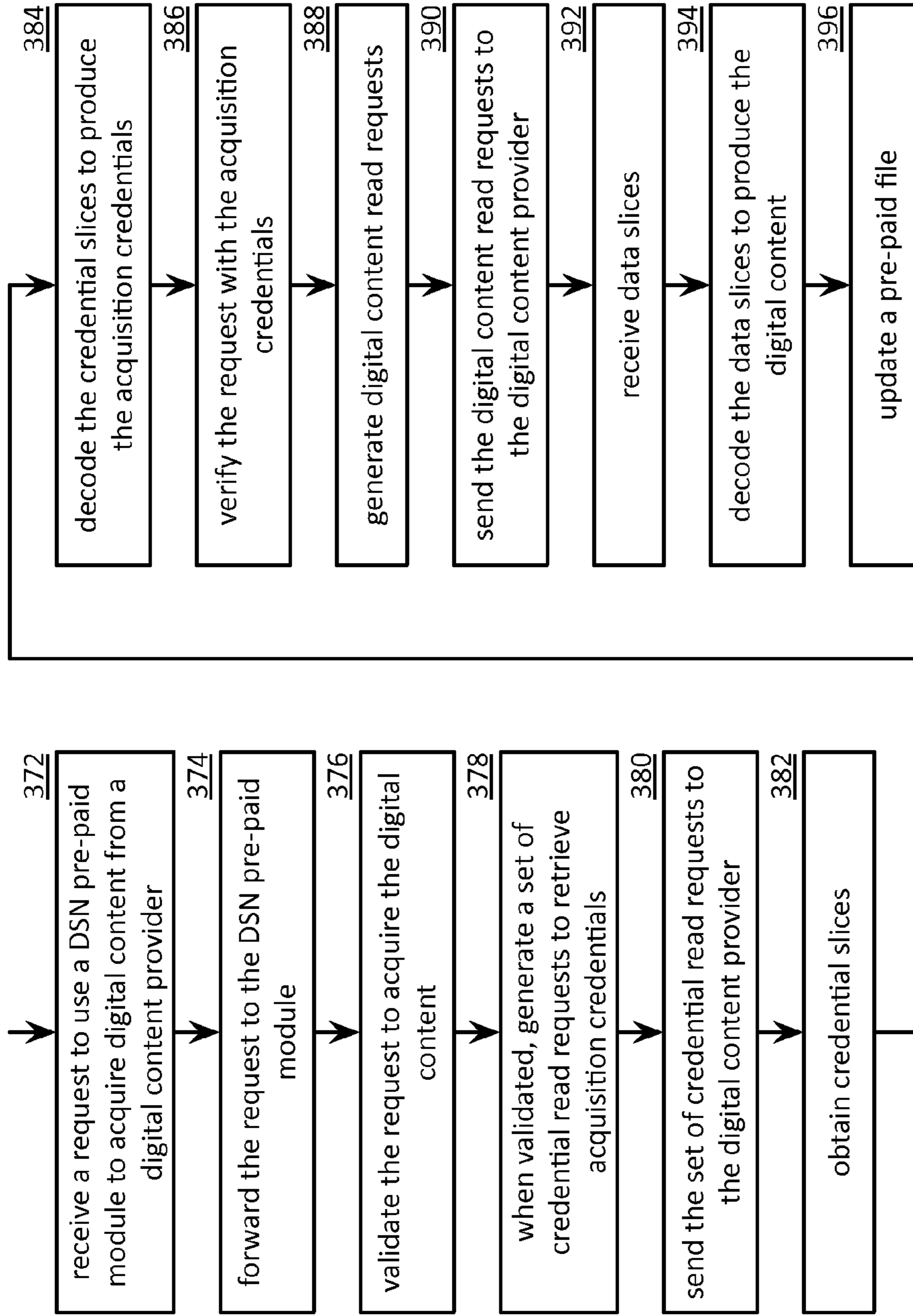
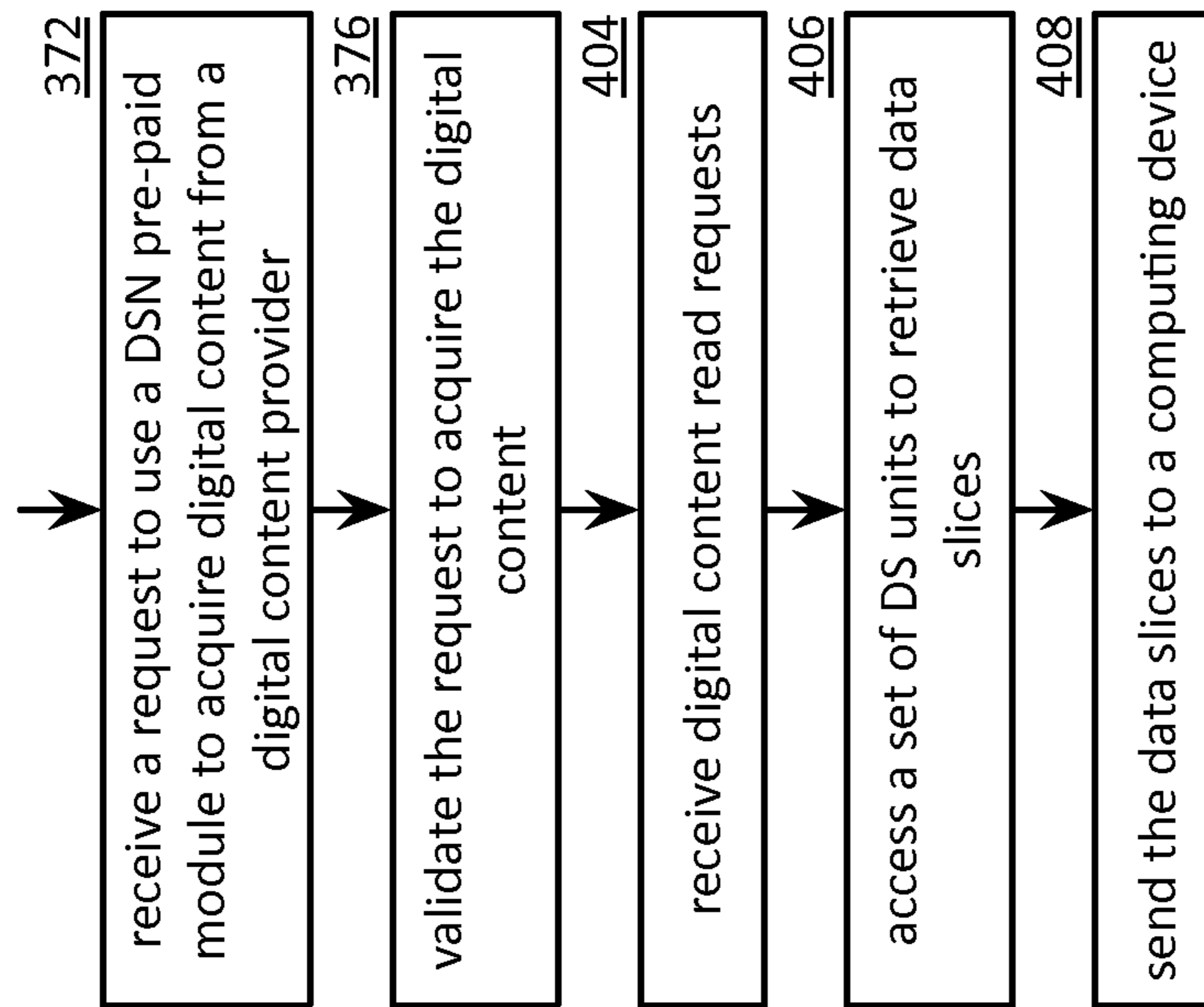

FIG. 13A



**FIG. 13B**



**FIG. 13C**

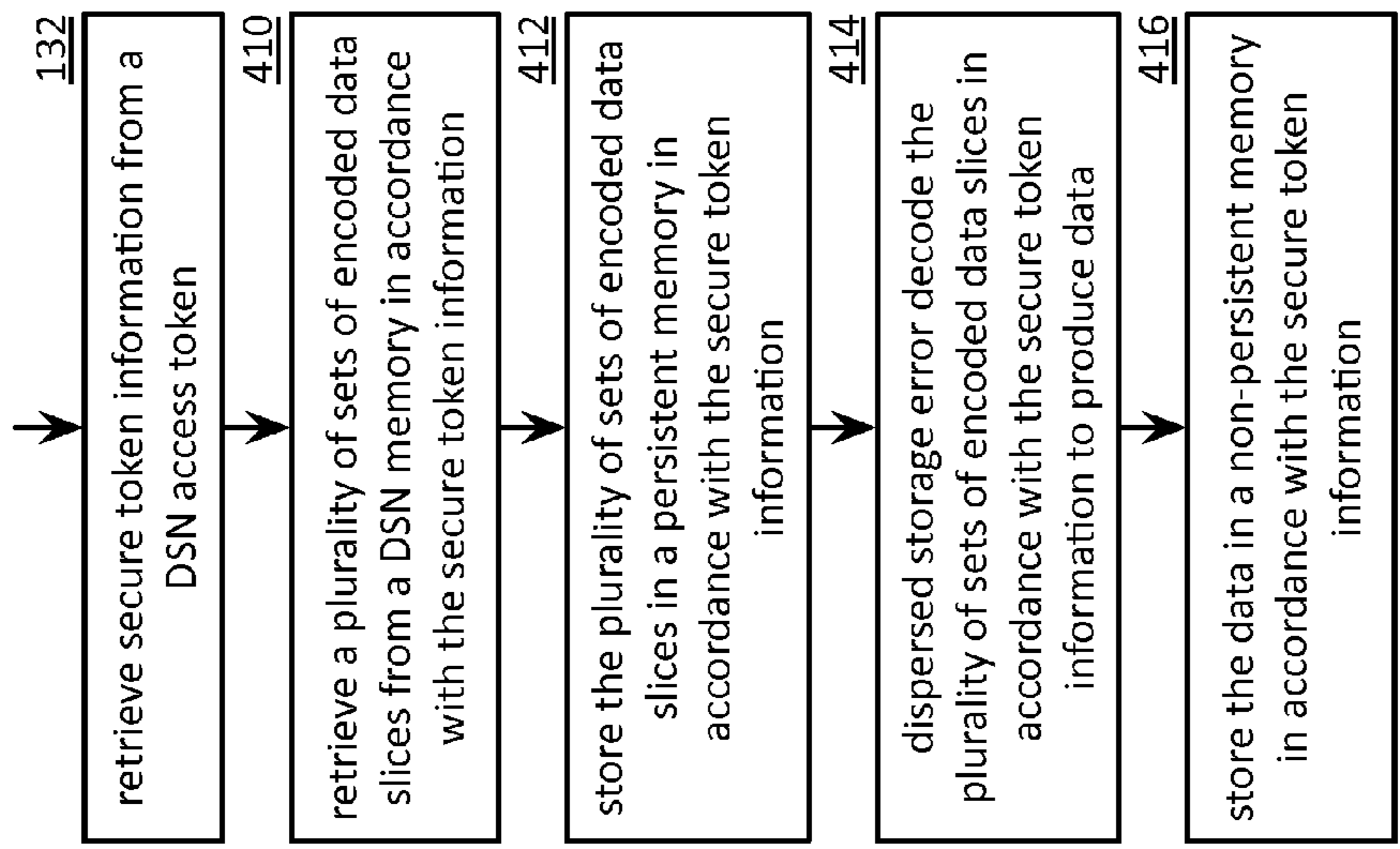

**FIG. 14**



1

**UTILIZING A DISPERSED STORAGE  
NETWORK ACCESS TOKEN MODULE TO  
ACQUIRE DIGITAL CONTENT FROM A  
DIGITAL CONTENT PROVIDER**

CROSS REFERENCE TO RELATED PATENTS

The present U.S. Utility patent application is claiming priority pursuant to 35 U.S.C. § 119(e) to U.S. Provisional Application No. 61/438,490, entitled "DISPERSED STORAGE NETWORK ACCESS TOKEN," filed Feb. 1, 2011, which is incorporated herein by reference in its entirety and made part of the present U.S. Utility patent application for all purposes.

STATEMENT REGARDING FEDERALLY  
SPONSORED RESEARCH OR DEVELOPMENT

NOT APPLICABLE

INCORPORATION-BY-REFERENCE OF  
MATERIAL SUBMITTED ON A COMPACT  
DISC

NOT APPLICABLE

BACKGROUND OF THE INVENTION

Technical Field of the Invention

This invention relates generally to computing systems and more particularly to data storage solutions within such computing systems.

Description of Related Art

Computers are known to communicate, process, and store data. Such computers range from wireless smart phones to data centers that support millions of web searches, stock trades, or on-line purchases every day. In general, a computing system generates data and/or manipulates data from one form into another. For instance, an image sensor of the computing system generates raw picture data and, using an image compression program (e.g., JPEG, MPEG, etc.), the computing system manipulates the raw picture data into a standardized compressed image.

With continued advances in processing speed and communication speed, computers are capable of processing real time multimedia data for applications ranging from simple voice communications to streaming high definition video. As such, general-purpose information appliances are replacing purpose-built communications devices (e.g., a telephone). For example, smart phones can support telephony communications but they are also capable of text messaging and accessing the internet to perform functions including email, web browsing, remote applications access, and media communications (e.g., telephony voice, image transfer, music files, video files, real time video streaming, etc.).

Each type of computer is constructed and operates in accordance with one or more communication, processing, and storage standards. As a result of standardization and with advances in technology, more and more information content is being converted into digital formats. For example, more digital cameras are now being sold than film cameras, thus producing more digital pictures. As another example, web-based programming is becoming an alternative to over the air television broadcasts and/or cable broadcasts. As further examples, papers, books, video entertainment, home video, etc. are now being stored digitally, which increases the demand on the storage function of computers.

2

A typical computer storage system includes one or more memory devices aligned with the needs of the various operational aspects of the computer's processing and communication functions. Generally, the immediacy of access dictates what type of memory device is used. For example, random access memory (RAM) memory can be accessed in any random order with a constant response time, thus it is typically used for cache memory and main memory. By contrast, memory device technologies that require physical movement such as magnetic disks, tapes, and optical discs, have a variable response time as the physical movement can take longer than the data transfer, thus they are typically used for secondary memory (e.g., hard drive, backup memory, etc.).

A computer's storage system will be compliant with one or more computer storage standards that include, but are not limited to, network file system (NFS), flash file system (FFS), disk file system (DFS), small computer system interface (SCSI), internet small computer system interface (iSCSI), file transfer protocol (FTP), and web-based distributed authoring and versioning (WebDAV). These standards specify the data storage format (e.g., files, data objects, data blocks, directories, etc.) and interfacing between the computer's processing function and its storage system, which is a primary function of the computer's memory controller.

Despite the standardization of the computer and its storage system, memory devices fail; especially commercial grade memory devices that utilize technologies incorporating physical movement (e.g., a disc drive). For example, it is fairly common for a disc drive to routinely suffer from bit level corruption and to completely fail after three years of use. One solution is to a higher-grade disc drive, which adds significant cost to a computer.

Another solution is to utilize multiple levels of redundant disc drives to replicate the data into two or more copies. One such redundant drive approach is called redundant array of independent discs (RAID). In a RAID device, a RAID controller adds parity data to the original data before storing it across the array. The parity data is calculated from the original data such that the failure of a disc will not result in the loss of the original data. For example, RAID 5 uses three discs to protect data from the failure of a single disc. The parity data, and associated redundancy overhead data, reduces the storage capacity of three independent discs by one third (e.g.,  $n-1$ =capacity). RAID 6 can recover from a loss of two discs and requires a minimum of four discs with a storage capacity of  $n-2$ .

While RAID addresses the memory device failure issue, it is not without its own failures issues that affect its effectiveness, efficiency and security. For instance, as more discs are added to the array, the probability of a disc failure increases, which increases the demand for maintenance. For example, when a disc fails, it needs to be manually replaced before another disc fails and the data stored in the RAID device is lost. To reduce the risk of data loss, data on a RAID device is typically copied on to one or more other RAID devices. While this addresses the loss of data issue, it raises a security issue since multiple copies of data are available, which increases the chances of unauthorized access. Further, as the amount of data being stored grows, the overhead of RAID devices becomes a non-trivial efficiency issue.

BRIEF DESCRIPTION OF THE SEVERAL  
VIEWS OF THE DRAWING(S)

FIG. 1 is a schematic block diagram of an embodiment of a computing system in accordance with the invention;

## 3

FIG. 2 is a schematic block diagram of an embodiment of a computing core in accordance with the invention;

FIG. 3 is a schematic block diagram of an embodiment of a distributed storage processing unit in accordance with the invention;

FIG. 4 is a schematic block diagram of an embodiment of a grid module in accordance with the invention;

FIG. 5 is a diagram of an example embodiment of error coded data slice creation in accordance with the invention;

FIG. 6 is a schematic block diagram of another embodiment of a computing system in accordance with the invention;

FIG. 7 is a flowchart illustrating an example of accessing a dispersed storage network (DSN) in accordance with the invention;

FIG. 8A is a schematic block diagram of another embodiment of a computing system in accordance with the invention;

FIG. 8B is a schematic block diagram of another embodiment of a computing system in accordance with the invention;

FIG. 8C is a flowchart illustrating an example of storing data in a dispersed storage network (DSN) in accordance with the invention;

FIG. 9A is a schematic block diagram of another embodiment of a computing system in accordance with the invention;

FIG. 9B is a schematic block diagram of another embodiment of a computing system in accordance with the invention;

FIG. 9C is a flowchart illustrating an example of retrieving data from a dispersed storage network (DSN) in accordance with the invention;

FIG. 10A is a flowchart illustrating another example of accessing a dispersed storage network (DSN) in accordance with the invention;

FIG. 10B is a flowchart illustrating an example of determining dispersed storage network (DSN) access information in accordance with the invention;

FIG. 11A is a schematic block diagram of another embodiment of a computing system in accordance with the invention;

FIG. 11B is a schematic block diagram of another embodiment of a computing system in accordance with the invention;

FIG. 11C is a flowchart illustrating another example of accessing a dispersed storage network (DSN) in accordance with the invention;

FIG. 12 is a flowchart illustrating an example of redistributing dispersed storage network (DSN) access information in accordance with the invention;

FIG. 13A is a schematic block diagram of another embodiment of a computing system in accordance with the invention;

FIG. 13B is a flowchart illustrating an example of accessing a content server in accordance with invention;

FIG. 13C is a flowchart illustrating an example of providing content in accordance with invention; and

FIG. 14 is a flowchart illustrating an example of retrieving secure information in accordance with invention.

#### DETAILED DESCRIPTION OF THE INVENTION

FIG. 1 is a schematic block diagram of a computing system 10 that includes one or more of a first type of user devices 12, one or more of a second type of user devices 14,

## 4

at least one distributed storage (DS) processing unit 16, at least one DS managing unit 18, at least one storage integrity processing unit 20, and a distributed storage network (DSN) memory 22 coupled via a network 24. The network 24 may include one or more wireless and/or wire lined communication systems; one or more private intranet systems and/or public internet systems; and/or one or more local area networks (LAN) and/or wide area networks (WAN).

The DSN memory 22 includes a plurality of distributed storage (DS) units 36 for storing data of the system. Each of the DS units 36 includes a processing module and memory and may be located at a geographically different site than the other DS units (e.g., one in Chicago, one in Milwaukee, etc.).

Each of the user devices 12-14, the DS processing unit 16, the DS managing unit 18, and the storage integrity processing unit 20 may be a portable computing device (e.g., a social networking device, a gaming device, a cell phone, a smart phone, a personal digital assistant, a digital music player, a digital video player, a laptop computer, a handheld computer, a video game controller, and/or any other portable device that includes a computing core) and/or a fixed computing device (e.g., a personal computer, a computer server, a cable set-top box, a satellite receiver, a television set, a printer, a fax machine, home entertainment equipment, a video game console, and/or any type of home or office computing equipment). Such a portable or fixed computing device includes a computing core 26 and one or more interfaces 30, 32, and/or 33. An embodiment of the computing core 26 will be described with reference to FIG. 2.

With respect to the interfaces, each of the interfaces 30, 32, and 33 includes software and/or hardware to support one or more communication links via the network 24 and/or directly. For example, interface 30 supports a communication link (wired, wireless, direct, via a LAN, via the network 24, etc.) between the first type of user device 14 and the DS processing unit 16. As another example, DSN interface 32 supports a plurality of communication links via the network 24 between the DSN memory 22 and the DS processing unit 16, the first type of user device 12, and/or the storage integrity processing unit 20. As yet another example, interface 33 supports a communication link between the DS managing unit 18 and any one of the other devices and/or units 12, 14, 16, 20, and/or 22 via the network 24.

In general and with respect to data storage, the system 10 supports three primary functions: distributed network data storage management, distributed data storage and retrieval, and data storage integrity verification. In accordance with these three primary functions, data can be distributedly stored in a plurality of physically different locations and subsequently retrieved in a reliable and secure manner regardless of failures of individual storage devices, failures of network equipment, the duration of storage, the amount of data being stored, attempts at hacking the data, etc.

The DS managing unit 18 performs distributed network data storage management functions, which include establishing distributed data storage parameters, performing network operations, performing network administration, and/or performing network maintenance. The DS managing unit 18 establishes the distributed data storage parameters (e.g., allocation of virtual DSN memory space, distributed storage parameters, security parameters, billing information, user profile information, etc.) for one or more of the user devices 12-14 (e.g., established for individual devices, established for a user group of devices, established for public access by the user devices, etc.). For example, the DS managing unit 18 coordinates the creation of a vault (e.g., a virtual memory

block) within the DSN memory **22** for a user device (for a group of devices, or for public access). The DS managing unit **18** also determines the distributed data storage parameters for the vault. In particular, the DS managing unit **18** determines a number of slices (e.g., the number that a data segment of a data file and/or data block is partitioned into for distributed storage) and a read threshold value (e.g., the minimum number of slices required to reconstruct the data segment).

As another example, the DS managing unit **18** creates and stores, locally or within the DSN memory **22**, user profile information. The user profile information includes one or more of authentication information, permissions, and/or the security parameters. The security parameters may include one or more of encryption/decryption scheme, one or more encryption keys, key generation scheme, and data encoding/decoding scheme.

As yet another example, the DS managing unit **18** creates billing information for a particular user, user group, vault access, public vault access, etc. For instance, the DS managing unit **18** tracks the number of times a user accesses a private vault and/or public vaults, which can be used to generate a per-access bill. In another instance, the DS managing unit **18** tracks the amount of data stored and/or retrieved by a user device and/or a user group, which can be used to generate a per-data-amount bill.

The DS managing unit **18** also performs network operations, network administration, and/or network maintenance. As at least part of performing the network operations and/or administration, the DS managing unit **18** monitors performance of the devices and/or units of the system **10** for potential failures, determines the devices' and/or units' activation status, determines the devices' and/or units' loading, and any other system level operation that affects the performance level of the system **10**. For example, the DS managing unit **18** receives and aggregates network management alarms, alerts, errors, status information, performance information, and messages from the devices **12-14** and/or the units **16, 20, 22**. For example, the DS managing unit **18** receives a simple network management protocol (SNMP) message regarding the status of the DS processing unit **16**.

The DS managing unit **18** performs the network maintenance by identifying equipment within the system **10** that needs replacing, upgrading, repairing, and/or expanding. For example, the DS managing unit **18** determines that the DSN memory **22** needs more DS units **36** or that one or more of the DS units **36** needs updating.

The second primary function (i.e., distributed data storage and retrieval) begins and ends with a user device **12-14**. For instance, if a second type of user device **14** has a data file **38** and/or data block **40** to store in the DSN memory **22**, it sends the data file **38** and/or data block **40** to the DS processing unit **16** via its interface **30**. As will be described in greater detail with reference to FIG. **2**, the interface **30** functions to mimic a conventional operating system (OS) file system interface (e.g., network file system (NFS), flash file system (FFS), disk file system (DFS), file transfer protocol (FTP), web-based distributed authoring and versioning (WebDAV), etc.) and/or a block memory interface (e.g., small computer system interface (SCSI), internet small computer system interface (iSCSI), etc.). In addition, the interface **30** may attach a user identification code (ID) to the data file **38** and/or data block **40**.

The DS processing unit **16** receives the data file **38** and/or data block **40** via its interface **30** and performs a distributed storage (DS) process **34** thereon (e.g., an error coding dispersal storage function). The DS processing **34** begins by

partitioning the data file **38** and/or data block **40** into one or more data segments, which is represented as Y data segments. For example, the DS processing **34** may partition the data file **38** and/or data block **40** into a fixed byte size segment (e.g.,  $2^1$  to  $2^n$  bytes, where  $n \geq 2$ ) or a variable byte size (e.g., change byte size from segment to segment, or from groups of segments to groups of segments, etc.).

For each of the Y data segments, the DS processing **34** error encodes (e.g., forward error correction (FEC), information dispersal algorithm, or error correction coding) and slices (or slices then error encodes) the data segment into a plurality of error coded (EC) data slices **42-48**, which is represented as X slices per data segment. The number of slices (X) per segment, which corresponds to a number of pillars n, is set in accordance with the distributed data storage parameters and the error coding scheme. For example, if a Reed-Solomon (or other FEC scheme) is used in an n/k system, then a data segment is divided into n slices, where k number of slices is needed to reconstruct the original data (i.e., k is the threshold). As a few specific examples, the n/k factor may be 5/3; 6/4; 8/6; 8/5; 16/10.

For each EC slice **42-48**, the DS processing unit **16** creates a unique slice name and appends it to the corresponding EC slice **42-48**. The slice name includes universal DSN memory addressing routing information (e.g., virtual memory addresses in the DSN memory **22**) and user-specific information (e.g., user ID, file name, data block identifier, etc.).

The DS processing unit **16** transmits the plurality of EC slices **42-48** to a plurality of DS units **36** of the DSN memory **22** via the DSN interface **32** and the network **24**. The DSN interface **32** formats each of the slices for transmission via the network **24**. For example, the DSN interface **32** may utilize an internet protocol (e.g., TCP/IP, etc.) to packetize the EC slices **42-48** for transmission via the network **24**.

The number of DS units **36** receiving the EC slices **42-48** is dependent on the distributed data storage parameters established by the DS managing unit **18**. For example, the DS managing unit **18** may indicate that each slice is to be stored in a different DS unit **36**. As another example, the DS managing unit **18** may indicate that like slice numbers of different data segments are to be stored in the same DS unit **36**. For example, the first slice of each of the data segments is to be stored in a first DS unit **36**, the second slice of each of the data segments is to be stored in a second DS unit **36**, etc. In this manner, the data is encoded and distributedly stored at physically diverse locations to improve data storage integrity and security.

Each DS unit **36** that receives an EC slice **42-48** for storage translates the virtual DSN memory address of the slice into a local physical address for storage. Accordingly, each DS unit **36** maintains a virtual to physical memory mapping to assist in the storage and retrieval of data.

The first type of user device **12** performs a similar function to store data in the DSN memory **22** with the exception that it includes the DS processing. As such, the device **12** encodes and slices the data file and/or data block it has to store. The device then transmits the slices **11** to the DSN memory via its DSN interface **32** and the network **24**.

For a second type of user device **14** to retrieve a data file or data block from memory, it issues a read command via its interface **30** to the DS processing unit **16**. The DS processing unit **16** performs the DS processing **34** to identify the DS units **36** storing the slices of the data file and/or data block based on the read command. The DS processing unit **16** may

also communicate with the DS managing unit **18** to verify that the user device **14** is authorized to access the requested data.

Assuming that the user device is authorized to access the requested data, the DS processing unit **16** issues slice read commands to at least a threshold number of the DS units **36** storing the requested data (e.g., to at least 10 DS units for a 16/10 error coding scheme). Each of the DS units **36** receiving the slice read command, verifies the command, accesses its virtual to physical memory mapping, retrieves the requested slice, or slices, and transmits it to the DS processing unit **16**.

Once the DS processing unit **16** has received a read threshold number of slices for a data segment, it performs an error decoding function and de-slicing to reconstruct the data segment. When Y number of data segments has been reconstructed, the DS processing unit **16** provides the data file **38** and/or data block **40** to the user device **14**. Note that the first type of user device **12** performs a similar process to retrieve a data file and/or data block.

The storage integrity processing unit **20** performs the third primary function of data storage integrity verification. In general, the storage integrity processing unit **20** periodically retrieves slices **45**, and/or slice names, of a data file or data block of a user device to verify that one or more slices have not been corrupted or lost (e.g., the DS unit failed). The retrieval process mimics the read process previously described.

If the storage integrity processing unit **20** determines that one or more slices is corrupted or lost, it rebuilds the corrupted or lost slice(s) in accordance with the error coding scheme. The storage integrity processing unit **20** stores the rebuilt slice, or slices, in the appropriate DS unit(s) **36** in a manner that mimics the write process previously described.

FIG. **2** is a schematic block diagram of an embodiment of a computing core **26** that includes a processing module **50**, a memory controller **52**, main memory **54**, a video graphics processing unit **55**, an input/output (IO) controller **56**, a peripheral component interconnect (PCI) interface **58**, an IO interface **60**, at least one IO device interface module **62**, a read only memory (ROM) basic input output system (BIOS) **64**, and one or more memory interface modules. The memory interface module(s) includes one or more of a universal serial bus (USB) interface module **66**, a host bus adapter (HBA) interface module **68**, a network interface module **70**, a flash interface module **72**, a hard drive interface module **74**, and a DSN interface module **76**. Note the DSN interface module **76** and/or the network interface module **70** may function as the interface **30** of the user device **14** of FIG. **1**. Further note that the IO device interface module **62** and/or the memory interface modules may be collectively or individually referred to as IO ports.

FIG. **3** is a schematic block diagram of an embodiment of a dispersed storage (DS) processing module **34** of user device **12** and/or of the DS processing unit **16**. The DS processing module **34** includes a gateway module **78**, an access module **80**, a grid module **82**, and a storage module **84**. The DS processing module **34** may also include an interface **30** and the DSnet interface **32** or the interfaces **68** and/or **70** may be part of user device **12** or of the DS processing unit **16**. The DS processing module **34** may further include a bypass/feedback path between the storage module **84** to the gateway module **78**. Note that the modules **78-84** of the DS processing module **34** may be in a single unit or distributed across multiple units.

In an example of storing data, the gateway module **78** receives an incoming data object that includes a user ID field

**86**, an object name field **88**, and the data object field **40** and may also receive corresponding information that includes a process identifier (e.g., an internal process/application ID), metadata, a file system directory, a block number, a transaction message, a user device identity (ID), a data object identifier, a source name, and/or user information. The gateway module **78** authenticates the user associated with the data object by verifying the user ID **86** with the DS managing unit **18** and/or another authenticating unit.

When the user is authenticated, the gateway module **78** obtains user information from the management unit **18**, the user device, and/or the other authenticating unit. The user information includes a vault identifier, operational parameters, and user attributes (e.g., user data, billing information, etc.). A vault identifier identifies a vault, which is a virtual memory space that maps to a set of DS storage units **36**. For example, vault **1** (i.e., user **1**'s DSN memory space) includes eight DS storage units (X=8 wide) and vault **2** (i.e., user **2**'s DSN memory space) includes sixteen DS storage units (X=16 wide). The operational parameters may include an error coding algorithm, the width n (number of pillars X or slices per segment for this vault), a read threshold T, a write threshold, an encryption algorithm, a slicing parameter, a compression algorithm, an integrity check method, caching settings, parallelism settings, and/or other parameters that may be used to access the DSN memory layer.

The gateway module **78** uses the user information to assign a source name **35** to the data. For instance, the gateway module **78** determines the source name **35** of the data object **40** based on the vault identifier and the data object. For example, the source name may contain a file identifier (ID), a vault generation number, a reserved field, and a vault identifier (ID). As another example, the gateway module **78** may generate the file ID based on a hash function of the data object **40**. Note that the gateway module **78** may also perform message conversion, protocol conversion, electrical conversion, optical conversion, access control, user identification, user information retrieval, traffic monitoring, statistics generation, configuration, management, and/or source name determination.

The access module **80** receives the data object **40** and creates a series of data segments **1** through Y **90-92** in accordance with a data storage protocol (e.g., file storage system, a block storage system, and/or an aggregated block storage system). The number of segments Y may be chosen or randomly assigned based on a selected segment size and the size of the data object. For example, if the number of segments is chosen to be a fixed number, then the size of the segments varies as a function of the size of the data object. For instance, if the data object is an image file of 4,194,304 eight bit bytes (e.g., 33,554,432 bits) and the number of segments Y=131,072, then each segment is 256 bits or 32 bytes. As another example, if segment sized is fixed, then the number of segments Y varies based on the size of data object. For instance, if the data object is an image file of 4,194,304 bytes and the fixed size of each segment is 4,096 bytes, the then number of segments Y=1,024. Note that each segment is associated with the same source name.

The grid module **82** receives the data segments and may manipulate (e.g., compression, encryption, cyclic redundancy check (CRC), etc.) each of the data segments before performing an error coding function of the error coding dispersal storage function to produce a pre-manipulated data segment. After manipulating a data segment, if applicable, the grid module **82** error encodes (e.g., Reed-Solomon,

Convolution encoding, Trellis encoding, etc.) the data segment or manipulated data segment into X error coded data slices **42-44**.

The value X, or the number of pillars (e.g., X=16), is chosen as a parameter of the error coding dispersal storage function. Other parameters of the error coding dispersal function include a read threshold T, a write threshold W, etc. The read threshold (e.g., T=10, when X=16) corresponds to the minimum number of error-free error coded data slices required to reconstruct the data segment. In other words, the DS processing module **34** can compensate for X-T (e.g., 16-10=6) missing error coded data slices per data segment. The write threshold W corresponds to a minimum number of DS storage units that acknowledge proper storage of their respective data slices before the DS processing module indicates proper storage of the encoded data segment. Note that the write threshold is greater than or equal to the read threshold for a given number of pillars (X).

For each data slice of a data segment, the grid module **82** generates a unique slice name **37** and attaches it thereto. The slice name **37** includes a universal routing information field and a vault specific field and may be 48 bytes (e.g., 24 bytes for each of the universal routing information field and the vault specific field). As illustrated, the universal routing information field includes a slice index, a vault ID, a vault generation, and a reserved field. The slice index is based on the pillar number and the vault ID and, as such, is unique for each pillar (e.g., slices of the same pillar for the same vault for any segment will share the same slice index). The vault specific field includes a data name, which includes a file ID and a segment number (e.g., a sequential numbering of data segments **1-Y** of a simple data object or a data block number).

Prior to outputting the error coded data slices of a data segment, the grid module may perform post-slice manipulation on the slices. If enabled, the manipulation includes slice level compression, encryption, CRC, addressing, tagging, and/or other manipulation to improve the effectiveness of the computing system.

When the error coded data slices of a data segment are ready to be outputted, the grid module **82** determines which of the DS storage units **36** will store the EC data slices based on a dispersed storage memory mapping associated with the user's vault and/or DS storage unit attributes. The DS storage unit attributes may include availability, self-selection, performance history, link speed, link latency, ownership, available DSN memory, domain, cost, a prioritization scheme, a centralized selection message from another source, a lookup table, data ownership, and/or any other factor to optimize the operation of the computing system. Note that the number of DS storage units **36** is equal to or greater than the number of pillars (e.g., X) so that no more than one error coded data slice of the same data segment is stored on the same DS storage unit **36**. Further note that EC data slices of the same pillar number but of different segments (e.g., EC data slice **1** of data segment **1** and EC data slice **1** of data segment **2**) may be stored on the same or different DS storage units **36**.

The storage module **84** performs an integrity check on the outbound encoded data slices and, when successful, identifies a plurality of DS storage units based on information provided by the grid module **82**. The storage module **84** then outputs the encoded data slices **1** through X of each segment **1** through Y to the DS storage units **36**. Each of the DS storage units **36** stores its EC data slice(s) and maintains a

local virtual DSN address to physical location table to convert the virtual DSN address of the EC data slice(s) into physical storage addresses.

In an example of a read operation, the user device **12** and/or **14** sends a read request to the DS processing unit **14**, which authenticates the request. When the request is authentic, the DS processing unit **14** sends a read message to each of the DS storage units **36** storing slices of the data object being read. The slices are received via the DSnet interface **32** and processed by the storage module **84**, which performs a parity check and provides the slices to the grid module **82** when the parity check was successful. The grid module **82** decodes the slices in accordance with the error coding dispersal storage function to reconstruct the data segment. The access module **80** reconstructs the data object from the data segments and the gateway module **78** formats the data object for transmission to the user device.

FIG. **4** is a schematic block diagram of an embodiment of a grid module **82** that includes a control unit **73**, a pre-slice manipulator **75**, an encoder **77**, a slicer **79**, a post-slice manipulator **81**, a pre-slice de-manipulator **83**, a decoder **85**, a de-slicer **87**, and/or a post-slice de-manipulator **89**. Note that the control unit **73** may be partially or completely external to the grid module **82**. For example, the control unit **73** may be part of the computing core at a remote location, part of a user device, part of the DS managing unit **18**, or distributed amongst one or more DS storage units.

In an example of a write operation, the pre-slice manipulator **75** receives a data segment **90-92** and a write instruction from an authorized user device. The pre-slice manipulator **75** determines if pre-manipulation of the data segment **90-92** is required and, if so, what type. The pre-slice manipulator **75** may make the determination independently or based on instructions from the control unit **73**, where the determination is based on a computing system-wide pre-determination, a table lookup, vault parameters associated with the user identification, the type of data, security requirements, available DSN memory, performance requirements, and/or other metadata.

Once a positive determination is made, the pre-slice manipulator **75** manipulates the data segment **90-92** in accordance with the type of manipulation. For example, the type of manipulation may be compression (e.g., Lempel-Ziv-Welch, Huffman, Golomb, fractal, wavelet, etc.), signatures (e.g., Digital Signature Algorithm (DSA), Elliptic Curve DSA, Secure Hash Algorithm, etc.), watermarking, tagging, encryption (e.g., Data Encryption Standard, Advanced Encryption Standard, etc.), adding metadata (e.g., time/date stamping, user information, file type, etc.), cyclic redundancy check (e.g., CRC32), and/or other data manipulations to produce the pre-manipulated data segment.

The encoder **77** encodes the pre-manipulated data segment **92** using a forward error correction (FEC) encoder (and/or other type of erasure coding and/or error coding) to produce an encoded data segment **94**. The encoder **77** determines which forward error correction algorithm to use based on a predetermination associated with the user's vault, a time based algorithm, user direction, DS managing unit direction, control unit direction, as a function of the data type, as a function of the data segment **92** metadata, and/or any other factor to determine algorithm type. The forward error correction algorithm may be Golay, Multidimensional parity, Reed-Solomon, Hamming, Bose Ray Chauduri Hocquenghem (BCH), Cauchy-Reed-Solomon, or any other FEC encoder. Note that the encoder **77** may use a different

## 11

encoding algorithm for each data segment **92**, the same encoding algorithm for the data segments **92** of a data object, or a combination thereof.

The encoded data segment **94** is of greater size than the data segment **92** by the overhead rate of the encoding algorithm by a factor of  $X/T$ , where  $X$  is the width or number of slices, and  $T$  is the read threshold. In this regard, the corresponding decoding process can accommodate at most  $X-T$  missing EC data slices and still recreate the data segment **92**. For example, if  $X=16$  and  $T=10$ , then the data segment **92** will be recoverable as long as 10 or more EC data slices per segment are not corrupted.

The slicer **79** transforms the encoded data segment **94** into EC data slices in accordance with the slicing parameter from the vault for this user and/or data segment **92**. For example, if the slicing parameter is  $X=16$ , then the slicer **79** slices each encoded data segment **94** into 16 encoded slices.

The post-slice manipulator **81** performs, if enabled, post-manipulation on the encoded slices to produce the EC data slices. If enabled, the post-slice manipulator **81** determines the type of post-manipulation, which may be based on a computing system-wide predetermination, parameters in the vault for this user, a table lookup, the user identification, the type of data, security requirements, available DSN memory, performance requirements, control unit directed, and/or other metadata. Note that the type of post-slice manipulation may include slice level compression, signatures, encryption, CRC, addressing, watermarking, tagging, adding metadata, and/or other manipulation to improve the effectiveness of the computing system.

In an example of a read operation, the post-slice de-manipulator **89** receives at least a read threshold number of EC data slices and performs the inverse function of the post-slice manipulator **81** to produce a plurality of encoded slices. The de-slicer **87** de-slices the encoded slices to produce an encoded data segment **94**. The decoder **85** performs the inverse function of the encoder **77** to recapture the data segment **90-92**. The pre-slice de-manipulator **83** performs the inverse function of the pre-slice manipulator **75** to recapture the data segment **90-92**.

FIG. 5 is a diagram of an example of slicing an encoded data segment **94** by the slicer **79**. In this example, the encoded data segment **94** includes thirty-two bits, but may include more or less bits. The slicer **79** disperses the bits of the encoded data segment **94** across the EC data slices in a pattern as shown. As such, each EC data slice does not include consecutive bits of the data segment **94** reducing the impact of consecutive bit failures on data recovery. For example, if EC data slice **2** (which includes bits **1, 5, 9, 13, 17, 25,** and **29**) is unavailable (e.g., lost, inaccessible, or corrupted), the data segment can be reconstructed from the other EC data slices (e.g., **1, 3** and **4** for a read threshold of 3 and a width of 4).

FIG. 6 is a schematic block diagram of another embodiment of a computing system that includes a plurality of user devices **14**, a network **24**, a dispersed storage network (DSN) memory **22**, a DSN access server **104**, a content server **106**, a wireless network **108**, and a DSN access token module **102**. The user device includes an interface **30**, an interface **32**, a computing core **26**, a persistent memory **110**, and a non-persistent memory **112**. The persistent memory **110** includes a memory type such that data persists when the persistent memory **110** receives no power (e.g., a disk drive, flash memory). The non-persistent memory **112** includes a memory type such that data does not persist when the non-persistent memory does not receive power (e.g., random access memory (RAM)).

## 12

In an embodiment, the DSN access token module **102** includes an interface **30**, a slice memory **114**, a secure token module **116**, a software memory **118**, a processing module **50**, and a wireless transceiver **120**. The slice memory **114** includes memory to store one or more of encoded data slices, slice names, slice integrity information, and slice location information. The secure token module **116** includes memory and/or memory and an associated processing module utilized to store and retrieve secure token information. The secure token module **116** provides access to the secure token information via one or more of a retrieval utilizing a secure token information address, receiving a read request message that includes the secure token information address, and receiving a read request message that includes the secure token information address and a secure token access credential. The secure token information includes one or more of access credentials, encryption algorithm information, a private key, a public key, a shared key, DSN addressing information, a vault identifier (ID), a user ID, storage payment information, storage payment plan information, storage credits, a DSN provider list, a location of dispersed storage (DS) processing software, dispersed storage error coding parameters, a storage payment alert, DSN access information, DS processing software redistribution information, encoded data slice storage rights, and data storage rights. The DSN access information includes one or more of the DSN addressing information, a DSN access credential, and the user ID.

The software memory **118** includes memory to store one or more of DS processing software, boot software, operating system (OS) software, application software, protocol conversion software, network access software, server access software, wireless network access software, and interface driver software. The wireless transceiver **120** includes a wireless transmitter and receiver pair and converts information into wireless signals **124** and converts the wireless signals **124** into information. The wireless transceiver **120** communicates the wireless signals **124** with the wireless network **108** and may operate in accordance with one or more wireless industry standards including universal mobile telecommunications system (UMTS), global system for mobile communications (GSM), long term evolution (LTE), wideband code division multiplexing (WCDMA), IEEE 802.11, IEEE 802.16, WiMax, Bluetooth, or any other LAN, WAN, PAN or like wireless protocol.

The DSN access server **104** provides storage for one or more of DS processing software, an access control list (ACL), and access credentials. The content server **106** provides storage for one or more of digital music content, digital book content, digital video content, and any other type of multimedia content.

In an implementation embodiment, the DSN access token module **102** resembles an external memory device (e.g., a FLASH drive), wherein the interface **30** operates in accordance with an industry universal serial bus protocol (USB) standard. For example, the DSN access token module **102** is coupled to the user device **14** such that DSN information **122** may be transferred back and forth between the user device **14** and the DSN access token module **102** utilizing interface **30** of the DSN access token **102** and interface **30** of the user device **14**. The DSN information **122** may be utilized to facilitate access to the DSN memory **22** and/or the content server **106** by the user device **14**. For example, the user device **14** acquires secure token information as the DSN information **122** from the DSN access token module **102** and utilizes the secure token information to access the DSN memory **22**.

As another example, the user device **14** acquires the secure token information from the DSN access token module **102**, acquires DS processing software from the DSN access token module **102**, dispersed storage error encodes data to produce encoded data slices for storage utilizing the DS processing software, and utilizes the secure token information to store the encoded data slices in the DSN memory **22**. As yet another example, the user device **14** sends data for storage to the DSN access token module **102** and the DSN access token module **102** dispersed storage error encodes the data to produce a plurality of sets of encoded data slices. Next, the DSN access token module **102** sends DSN access information **122** (e.g., a DSN address, an access credential) and the plurality of sets of encoded data slices to the user device **14**. The user device **14** sends the plurality of sets of encoded data slices to the DSN memory **22** utilizing the DSN access information **122** for storage therein. The method of operation is discussed in greater detail with reference to FIGS. 7-14.

Alternatively, the DSN access token module **102** is implemented as a software module. For example, the DSN access token module **102** is implemented in the user device **14**. As another example, the DSN access token module **102** is implemented in the DSN access server **104**.

FIG. 7 is a flowchart illustrating an example of accessing a dispersed storage network (DSN). The method begins with step **130** where a processing module (e.g., of a user device) determines to access a dispersed storage network (DSN). The determination may be based on one or more of a retrieval request, a storage request, a message, a storage capacity requirement exceeding a local storage threshold, and detection/pairing of a DSN access token module. The processing module may retrieve boot software from the DSN access token module to enable execution of at least some of the following steps.

The method continues at step **132** where the processing module retrieves secure token information from the DSN access token module. The processing module may retrieve the secure token information by one or more of retrieving the secure token information utilizing a secure token module address and sending a secure token information request message to the DSN access token module. The method continues at step **134** where the processing module determines where to obtain dispersed storage (DS) processing software based on the secure token information. The determination may be based on one or more of extracting the location from the secure token information, extracting a location of the location from the secure token information, and a user device query to determine whether the DS processing software is stored in a memory of an associated user device. The location may indicate one or more of a DSN access server identifier (ID) and/or address, and a DS software memory address within the DSN access token module, a user device ID. For example, the processing module determines a location to obtain the DS processing software as an address within the DS software memory of the DSN access token module based on extracting the location from the secure token information.

The method continues at step **136** where the processing module obtains the DS processing software based on the location. For example, the processing module retrieves the DS processing software from the DS software memory of the DSN access token module. As another example, the processing module sends a DS processing software request message to a processing module of the DSN access token module. The processing module of the DSN access token module retrieves the DS processing software from the DS

software memory and sends the DS processing software to the processing module (e.g., of the user device). As yet another example, the processing module sends a DS processing software request message to a DSN access server. The DSN access server retrieves the DS processing software from a memory of the DSN access server and sends the DS processing software to the processing module (e.g., of the user device). As a further example, the processing module sends a DS processing software request message to another user device. The another user device retrieves the DS processing software from a memory of the another user device and sends the DS processing software to the processing module (e.g., of the user device). The processing module may obtain the DS processing software from a second location when a retrieval attempt from a first a location fails.

The method continues at step **138** where the processing module extracts DSN access information from the secure token information. The extraction may include determining which component of the secure token information comprises the DSN access information to produce identify components and obtaining one or more of the identified components. The determining may be based on one or more of a DSN access procedure, a DSN ID, a message, a predetermination, and a query. The method continues at step **140** where the processing module sends a DSN access request that includes at least some of the DSN access information. The processing module may append a user password (e.g., input from a user of a user device, stored in a local memory associated with the processing module of user device) and or a hash of the user password to the access request. The DSN access request includes at least one of a read request, a read-if-modified request, a write request, a check write request, a modify request, a replacement request, a delete request, a list request, and a commit transaction request. For example, the processing module sends the DSN access request which includes a write request to a DSN address of the DSN access information, wherein the DSN access request includes an access credential and a hash of a user password.

FIG. 8A is a schematic block diagram of another embodiment of a computing system that includes a user device **14**, a network **24**, a dispersed storage network (DSN) memory **22**, and a DSN access token module **142**. The DSN access token module **142** includes an interface module **30** for interfacing with the computing device **14**, a memory **144**, and a processing module **50** operably coupled to the memory **144**. The interface module **30** includes at least one of a universal serial bus (USB) interface module, a Bluetooth interface module, a fire-wire interface module, a 60 GHz wireless transceiver, and a Wi-Fi interface module.

The processing module **50** is operable to manage a pairing between the DSN access token module **142** and the computing device **14**. The managing the pairing includes determining whether the DSN access token module **142** is actively paired to the computing device **14** and when the DSN access token module **142** is not actively paired to the computing device **14**, facilitating pairing of the DSN access token module **142** to the computing device **14**. The managing the pairing further includes authenticating one or more of a vault identifier (ID) of the DSN memory associated with the computing device, an object number associated with the computing device, an access credential of the computing device, a key of the computing device, a user device ID associated with the computing device, and a password associated with the computing device.

When the computing device **14** is paired with the DSN access token module **142**, the processing module **50** is further operable to receive, from the computing device **14**

## 15

via the interface module 30, at least a portion of data 146 to be stored in DSN memory 22; encode the at least a portion of the data 146 using a dispersed storage error encoding function to produce one or more sets of encoded data slices 148; and send, via the interface module 30, the one or more sets of encoded data slices 148 and storage information 150 to the computing device 14, wherein the storage information 150, when processed by the computing device 14, causes the computing device to send the one or more sets of encoded data slices 148 in accordance with the storage information 150 to the DSN memory 22 for storage therein.

The receiving the at least a portion of the data 146 further includes sending a data segmenting command to the computing device 14 that, when executed by the computing device 14, causes the computing device 14 to segment the data in accordance with the data segmenting command to produce data segments and receiving, from the computing device 14, one of the data segments as the at least a portion of the data 146. The storage information 150 includes a set of write requests for a set of the one or more sets of encoded data slices 148, wherein a write request of the set of write requests includes a slice name for a corresponding one of the encoded data slices 148 of the set and DSN addressing information for the corresponding one of the encoded data slices 148.

FIG. 8B is a schematic block diagram of another embodiment of a computing system that includes a user device 14, a network 24, a dispersed storage network (DSN) memory 22, and a DSN access token module 142. The user device 14 includes a module for facilitating storage of data 146 in a dispersed storage network (DSN) memory 22. The module includes a determine location module 150, a manage pairing module 152, a send data module 154, a receive slices module 156, and a send slices module 158. The determine location module 150 is operable to determine where to store the data 146. The determine location module 150 is further operable to determine where to store the data 146 by at least one of interpreting a write request 160 regarding the data 146, wherein the write request 160 indicates storing the data 146 in the DSN memory 22, receiving a response to a graphical user interface prompt regarding storage location of the data 146, and when the computing device 14 is paired with the DSN access token module 142, indicating storage in the DSN memory 22.

The manage pairing module 152 is operable to participate in managing a pairing between the DSN access token module 142 and the computing device 14 when the data 146 is to be stored in the DSN memory 22. The participating in the managing of the pairing comprises providing, for authentication by the DSN access token module 142, pairing information 162 including at least one of a vault identifier (ID) of the DSN memory 22 associated with the computing device 14, an object number associated with the computing device 14, an access credential of the computing device 14, a key of the computing device 14, a user device ID associated with the computing device 14, and a password associated with the computing device 14.

The send data module 154 is operable to send at least a portion of the data 146 to the DSN access token module 142 when the computing device 142 is paired with the DSN access token module 142, wherein the DSN access token module 142 encodes the at least a portion of the data 146 using a dispersed storage error encoding function to produce one or more sets of encoded data slices 148. The send data module 154 is further operable to receive, from the DSN access token module 142, a data segmenting command to the computing device 14; segment the data 146 in accordance

## 16

with the data segmenting command to produce data segments; and send one of the data segments as the at least a portion of the data 146.

The receive slices module 156 is operable to receive, from the DSN access token module 142, the one or more sets of encoded data slices 148 and storage information 150 to the computing device. The storage information 150 includes a set of write requests for a set of the one or more sets of encoded data slices 148, wherein a write request of the set of write requests includes a slice name for a corresponding one of the encoded data slices of the set and DSN addressing information for the corresponding one of the encoded data slices 148. The send slices module 158 is operable to send the one or more sets of encoded data slices 148 in accordance with the storage information 150 to the DSN memory 22 for storage therein.

FIG. 8C is a flowchart illustrating an example of storing data in a dispersed storage network (DSN). The method begins with step 170 where a computing device (e.g., a user device) determines where to store the data. The determining where to store the data further includes at least one of interpreting a write request regarding the data, wherein the write request indicates storing the data in the DSN memory, receiving a response to a graphical user interface prompt regarding storage location of the data, and indicating storage in the DSN memory when the computing device is paired with the DSN access token module. The write request may further include one or more of the data, a data type indicator, a data size indicator, a data identifier (ID), a filename, a vault ID, an object number associated with the data, and a file ID.

The method continues at step 172 where a DSN access token module manages a pairing between the DSN access token module and the computing device when the data is to be stored in dispersed storage network (DSN) memory. The managing the pairing includes authenticating one or more of a vault identifier (ID) of the DSN memory associated with the computing device, an object number associated with the computing device, an access credential of the computing device, a key of the computing device, a user device ID associated with the computing device, and a password associated with the computing device. The managing the pairing further includes determining whether the DSN access token module is actively paired to the computing device and facilitating pairing of the DSN access token module to the computing device when the DSN access token module is not actively paired to the computing device.

The method continues at step 174 where the computing device sends at least a portion of the data to the DSN access token module when the computing device is paired with the DSN access token module. The computing device sending the at least a portion of the data to the DSN access token module further includes sending, by the DSN access token module, a data segmenting command to the computing device; segmenting, by the computing device, the data in accordance with the data segmenting command to produce data segments; and sending, by the computing device, one of the data segments as the at least a portion of the data. The segmenting may be in accordance with a segmentation approach and based on at least one of a predetermined segment size, a segment size retrieved from the DSN access token module, a segment size retrieved from a memory associated with the computing device, and a segment size based on the data size indicator. For example, the computing device extracts the data segment size from secure token information retrieved from the DSN access token and segments the data in accordance with the data segment size to produce a plurality of data segments.



The method continues at step 176 where the DSN access token module encodes the at least a portion of the data using a dispersed storage error encoding function in accordance with dispersed storage error coding parameters (e.g., obtained from a memory of the DSN access token module) to produce one or more sets of encoded data slices. The method continues at step 178 where the DSN access token module sends the one or more sets of encoded data slices and storage information to the computing device. The storage information includes a set of write requests for a set of the one or more sets of encoded data slices, wherein a write request of the set of write requests includes a slice name for a corresponding one of the encoded data slices of the set and DSN addressing information for the corresponding one of the encoded data slices. The method continues at step 181 where the computing device sends the one or more sets of encoded data slices in accordance with the storage information to the DSN memory for storage therein.

FIG. 9A is a schematic block diagram of another embodiment of a computing system that includes a user device 14 (e.g., a computing device), a network 24, a dispersed storage network (DSN) memory 22, and a DSN access token module 142. The DSN access token module 142 includes an interface module 30 for interfacing with the computing device 14, a memory 144, and a processing module 50 operably coupled to the memory 144. The interface module 30 includes at least one of a universal serial bus (USB) interface module, a Bluetooth interface module, a fire-wire interface module, a 60 GHz wireless transceiver, and a Wi-Fi interface module.

The processing module 50 is operable to manage a pairing between the DSN access token module 142 and the computing device 14. The managing the pairing includes determining whether the DSN access token module 142 is actively paired to the computing device 14 and when the DSN access token module 142 is not actively paired to the computing device 14, facilitating pairing of the DSN access token module 142 to the computing device 14. The managing the pairing further includes authenticating one or more of a vault identifier (ID) of the DSN memory associated with the computing device, an object number associated with the computing device, an access credential of the computing device, a key of the computing device, a user device ID associated with the computing device, and a password associated with the computing device.

When the DSN access token module 142 is paired with the computing device 14, the processing module 50 is operable to receive a data retrieval request 182 regarding the data from the computing device 14, generate a plurality of sets of at least a threshold number of data slice read requests 184 in response to the data retrieval request, and send the plurality of sets of the at least a threshold number of data slices read requests 184 to the computing device 14. The data retrieval request 182 may include one or more of a data identifier (ID), a file ID, a filename, a user ID, a vault ID, and a password. The generating the plurality of sets of the at least a threshold number of data slice read requests 184 further includes one or more of authenticating the data retrieval request 182; when the data retrieval request 182 is authenticated, determining, for the data, DSN data storage information, which includes one or more of vault identification (ID), user ID, slice names, and a list of dispersed storage (DS) units; and generating the plurality of sets of the at least a threshold number of data slice read requests 184 based on the DSN data storage information.

The processing module 50 is operable to, for a set of the plurality of sets of the at least a threshold number of data

slices read requests, receive at least a threshold number of data slices 186 from the computing device 14, where the computing device 14 received the at least a threshold number of data slices 186 from the DSN memory 22 in response to the set of the at least a threshold number of data slices read requests 184, decode the at least a threshold number of data slices 186 in accordance with a dispersed storage error encoding function to produce a decoded data segment 188, and send the decoded data segment 188 to the computing device 14. The processing module 50 is further operable to send de-segmenting information to the computing device such that, when performed by the computing device, the computing device de-segments a plurality of data segments to produce the data, wherein the plurality of data segments includes the decoded data segment 188.

FIG. 9B is a schematic block diagram of another embodiment of a computing system that includes a user device 14, a network 24, a dispersed storage network (DSN) memory 22, and a DSN access token module 142. The user device 14 includes a module for facilitating retrieval of data 212 from a dispersed storage network (DSN) memory 22. The module includes a determine retrieval location module 190, a send request module 192, a receive requests module 194, a send slice requests module 196, a receive threshold slices module 198, a send threshold slices module 200, a receive segment module 202, a receive information module 204, and a de-segment module 206.

The determine retrieval location module 190 is operable to determine that the data 212 is stored in the DSN memory 22, wherein the data 212 is stored as a plurality of sets of encoded data slices in accordance with a dispersed storage error encoding function. The determine retrieval location module 190 is further operable to interpret a read request 208 regarding the data to determine that the data 212 is stored in the DSN memory 22, wherein the read request 208 indicates that the data 212 is stored in the DSN memory 22; receive a response to a graphical user interface prompt regarding retrieval of the data 212 to determine that the data 212 is stored in the DSN memory 22; and when the computing device 14 is paired with the DSN access token module 142, indicating that the data 212 is stored in the DSN memory 22.

The send request module 192 is operable to send a data retrieval request 182 to the DSN access token module 142 regarding the data 212 when the computing device 14 that includes the module is paired with the DSN access token module 142. The receive requests module 194 is operable to receive a plurality of sets of at least a threshold number of data slices read requests 184 from the DSN access token module 142, wherein the DSN access token module 142 generated the plurality of sets of at least a threshold number of data slice read requests 184 in response to the data retrieval request 182.

The send slice requests module 196 is operable, for a set of the plurality of sets of the at least a threshold number of data slices read requests 184, to send the set of the at least a threshold number of data slices read requests 184 to the DSN memory 22. The receive threshold slices module 198 is operable to receive at least a threshold number of data slices 186 from the DSN memory 22. The send threshold slices module 200 is operable to send the at least a threshold number of data slices 186 to the DSN access token module 142.

The receive segment module 202 is operable to receive a decoded data segment 188 from the DSN access token module 142, wherein the DSN access token module 142 decoded the at least a threshold number of data slices 186 in

accordance with the dispersed storage error encoding function to produce the decoded data segment **188**. The receive information module **204** is operable to receive de-segmenting information **210** from the DSN access token module **142**. The de-segmenting information **210** includes one or more of a data segment size indicator, a data segmentation approach, and a number of data segments. The de-segment module **206** is operable to de-segment a plurality of data segments in accordance with the de-segmenting information **210** to reproduce the data **212**, wherein the plurality of data segments includes the decoded data segment **188**.

FIG. **9C** is a flowchart illustrating an example of retrieving data from a dispersed storage network (DSN). The method begins at step **220** where a computing device (e.g., a user device) determines that the data is stored in dispersed storage network (DSN) memory, wherein the data is stored as a plurality of sets of encoded data slices in accordance with a dispersed storage error encoding function. The determining that the data is stored in the DSN memory includes one or more of interpreting a read request regarding the data, wherein the read request indicates that the data is stored in the DSN memory, receiving a response to a graphical user interface prompt regarding retrieval of the data, and when the computing device is paired with a DSN access token module, indicating that the data is stored in the DSN memory.

The method continues at step **222** where the DSN access token module manages the pairing between the DSN access token module and the computing device by authenticating one or more of a vault identifier (ID) of the DSN memory associated with the computing device, an object number associated with the computing device, an access credential of the computing device, a key of the computing device, a user device ID associated with the computing device, and a password associated with the computing device. The managing of the pairing between the DSN access token module and the computing device by further includes determining whether the DSN access token module is actively paired to the computing device and when the DSN access token module is not actively paired to the computing device, facilitating pairing of the DSN access token module to the computing device.

The method continues at step **224** where the computing device sends a data retrieval request to the DSN access token module regarding the data when the computing device is paired with a DSN access token module. The method continues at step **226** where the DSN access token module generates a plurality of sets of at least a threshold number of data slice read requests in response to the data retrieval request. The generating of the plurality of sets of the at least a threshold number of data slice read requests includes one or more of authenticating the data retrieval request; when the data retrieval request is authenticated, determining, for the data, DSN data storage information, which includes one or more of vault identification (ID), user ID, slice names, and a list of dispersed storage (DS) units; and generating the plurality of sets of the at least a threshold number of data slice read requests based on the DSN data storage information.

The method continues at step **228** where the DSN access token module sends the plurality of sets of the at least a threshold number of data slices read requests to the computing device. The method continues at step **230** for a set of the plurality of sets of the at least a threshold number of data slices read requests where the computing device sends the set of the at least a threshold number of data slices read requests to the DSN memory. The method continues at step

**232** where the computing device receives at least a threshold number of data slices from the DSN memory. The method continues at step **234** where the computing device sends the at least a threshold number of data slices to the DSN access token module. The method continues at step **236** where the DSN access token module decodes the at least a threshold number of data slices in accordance with the dispersed storage error encoding function to produce a decoded data segment. The method continues at step **238** where the DSN access token module sends the decoded data segment to the computing device.

The method continues at step **240** where the DSN access token module sends de-segmenting information to the computing device. The method continues at step **242** where the computing device de-segments a plurality of data segments in accordance with the de-segmenting information to reproduce the data, wherein the plurality of data segments includes the decoded data segment.

FIG. **10A** is a flowchart illustrating another example of accessing a dispersed storage network (DSN), which includes similar steps to FIG. **7**. The method begins with step **132** of FIG. **7** where a processing module (e.g., of a user device) retrieves secure token information from a DSN access token module. The secure token information may include additional information including one or more of a DSN provider list, DSN storage plan information, DSN storage rates, a prepaid storage credit indicator, and a DSN storage alert (e.g., further payment required to continue to store data in a DSN network). The processing module may output at least some of the secure token information via a user interface (e.g., a user display) to prompt a user for DSN storage information input. The method continues at step **244** where the processing module receives DSN storage information input. For example, the processing module receives the DSN storage information input including a selected DSN provider, a selected DSN storage plan, and payment information. The method continues at step **246** where the processing module sends the DSN storage information to the DSN access token module.

The method continues at step **248** where the processing module receives DSN access information. The DSN access information may be based on the DSN storage information. For example, the processing module receives the DSN access information including a DSN address associated with a selected DSN provider. The method continues at step **250** where the processing module accesses a DSN memory in accordance with the DSN access information (e.g., utilizing the DSN address, a credential, the user ID, and a password). The accessing may include at least one of reading slices, writing slices, deleting slices, listing slices, modifying slices, and replacing slices.

The method continues at step **252** where the processing module determines DSN storage statistics. The DSN storage statistics includes one or more of an amount of data stored, time duration of data stored, a payment cost indicator, a current payment balance, a payment required indicator, a data access availability indicator, and a data storage reliability indicator. The determination may be based on one or more of retrieving a storage history record, a DSN query, and a message. The method continues at step **254** where the processing module sends the DSN storage statistics to the DSN access token module.

FIG. **10B** is a flowchart illustrating an example of determining dispersed storage network (DSN). The method begins with step **256** where a processing module (e.g., of a dispersed storage network (DSN) access token) receives a secure token information request (e.g., from a user device).

For example, the secure token information request includes DSN storage statistics. The method continues at step 258 where the processing module retrieves secure token information (e.g., from a secure token module, from a local memory). The method continues at step 260 where the processing module sends the secure token information to the user device. The sending a secure token information may include generating an alert and sending the alert as part of the secure token information. For example, the processing module includes a DSN storage alert in the secure token information when the processing module determines that insufficient payment has been received for DSN storage services.

The method continues at step 262 where the processing module receives DSN storage information (e.g., from a user device). The DSN storage information may include user selections. The method continues at step 264 where the processing module determines DSN access information based on the DSN storage information. For example, the processing module retrieves one or more of a DSN address, DSN access credentials, an access credential, and an encryption key based on a memory lookup corresponding to a DSN provider selection of the DSN storage information. The method continues at step 266 where the processing module sends the DSN access information to the user device.

FIG. 11A is a schematic block diagram of another embodiment of a computing system that includes a user device 14 (e.g., a computing device), a network 24, a dispersed storage network (DSN) memory 22, and a DSN access token module 142. The DSN access token module 142 includes an interface module 30 for interfacing with the computing device 14, a memory 144, and a processing module 50 operably coupled to the memory 144. The interface module 30 includes at least one of a universal serial bus (USB) interface module, a Bluetooth interface module, a fire-wire interface module, a 60 GHz wireless transceiver, and a Wi-Fi interface module.

When the DSN access token module 142 is paired with a computing device 14, the processing module is operable to retrieve a plurality of sets of at least a threshold number of dispersed storage (DS) error coding function slices 270 from the DSN memory 22 via the computing device 14, determine decoding responsibilities based on DS processing features of the computing device 14, decode, in accordance with the decoding responsibilities, at least some of the plurality of sets of the at least a threshold number of DS error coding function slices 270 using a default DS error coding function to recapture at least a portion of a DS error coding function 278, determine executing responsibilities based on the DS processing features of the computing device 14, and execute, in accordance with the executing responsibilities, at least a portion of the DS error coding function 278 to access the DSN memory 22 regarding the data.

The DS processing features of the computing device 14 includes one or more of a storage capacity indicator, a central processing unit (CPU) speed capability indicator, an average CPU loading indicator, a software element identifier (ID), software version information, an interface type indicator, a number of interfaces indicator, a memory capacity indicator, a memory loading indicator, a memory type indicator, a operational status indicator, a performance indicator, and a hardware list. For example, the processing module 50 determines the decoding responsibilities to include the DSN access token module 142 to perform all decoding when the average CPU loading indicator of the computing device 14 indicates that the loading is above a high loading threshold. As another example, the processing module 50 determines

the executing responsibilities to include the computing device 14 to perform all of the DS error coding function 278 when the performance indicator indicates that a performance level associated with the computing device 14 is above a computing level threshold.

The retrieving the plurality of sets of the at least a threshold number of DS error coding function slices 270 further includes receiving, from the computing device, a DSN access request 272 regarding data 274 to the DSN access token module 142, determining the DS error coding function 278 in response to the DSN access request 272, determining DSN storage information for the DS error coding function, generating a plurality of sets of at least a threshold number of DS error coding function slice read requests 276 based on the DSN storage information, sending the plurality of sets of the at least a threshold number of DS error coding function slices read requests 276 to DSN memory 22 via the computing device 14, receiving the plurality of sets of the at least a threshold number of DS error coding function slices 270 from the DSN memory 22 via the computing device 14.

The processing module 50 is further operable to store the DS error coding function 278 in memory 144 of the DSN access token module 142 and facilitate the computing device 14 to access the memory 144 to retrieve at least a portion of the DS error coding function 278 such that the computing device 14 executes, in accordance with the executing responsibilities, a remaining portion the DS error coding function 278 to access the DSN memory 22 regarding the data 274. The processing module 50 is further operable to delete the DSN error coding function 278 from the memory 144 of the DSN access token module 142 when execution of the DSN error coding function 278 to access the DSN memory 22 regarding the data 274 is complete.

The processing module 50 is further operable to determine that the accessing of the DSN 22 is regarding a data retrieval request (e.g., of the DSN access request 272) and wherein the executing the at least a portion of the DS error coding function 278 to access the DSN memory 22 regarding the data 274 includes generating a plurality of sets of at least a threshold number of data slice read requests 280 in response to the data retrieval request and for a set of the plurality of sets of the at least a threshold number of data slices read requests 280 sending the set of the at least a threshold number of data slices read requests 280 to the DSN memory 22 via the computing device 22, receiving at least a threshold number of data slices 282 (e.g., read data slices) from the DSN memory 22 via the computing device, and decoding the at least a threshold number of data slices 282 in accordance with the DS error coding function 278 to produce a decoded data segment.

The processing module 50 is further operable to determine that the accessing of the DSN 22 is regarding a data write request (e.g., detecting a write request of the DSN access request 272) and wherein the executing the at least a portion of the DS error coding function 278 to access the DSN memory 22 regarding the data 274 includes encoding at least a portion of the data 274 using the DS error coding function 278 to produce one or more sets of encoded data slices 284 (e.g., write data slices), generating storage information regarding the one or more sets of encoded data slices 284, and sending the one or more sets of encoded data slices 284 in accordance with the storage information (e.g., a DSN address) to the DSN memory 22 via the computing device 14.

The processing module 50 is further operable to manage the pairing between the DSN access token module 142 and

the computing device **14** by at least one of authenticating one or more of a vault identifier (ID) of the DSN memory **22** associated with the computing device **14**, an object number associated with the computing device **14**, an access credential of the computing device **14**, a key of the computing device **14**, a user device ID associated with the computing device **14**, and a password associated with the computing device **14**; and determining whether the DSN access token module **142** is actively paired to the computing device **14** and, when the DSN access token module **142** is not actively paired to the computing device **14**, facilitating pairing of the DSN access token module **142** to the computing device **14**.

FIG. **11B** is a schematic block diagram of another embodiment of a computing system that includes a user device **14** (e.g., a computing device), a network **24**, a dispersed storage network (DSN) memory **22**, and a DSN access token module **142**. The computing device **14** includes a module for facilitating accessing the DSN memory **22** regarding data **274**. The module includes a determine DSN access module **290**, a retrieve dispersed storage (DS) error coding function slices module **292**, a decode slices module **294**, and an execute coding function module **296**. The determine DSN access module **290** is operable to determine that the DSN memory **22** is to be accessed regarding the data **274**. For example, the DSN access module **290** determines that the DSN memory **22** is to be accessed when a DSN access request **272** is received indicating accessing the DSN memory **22** with regards to the data **274**.

When the computing device **14** is paired with the DSN access token module **142**, the retrieve DS error coding function slices module **292** is operable to retrieve, in response to a request (e.g., DS error coding function slices read requests **276**) from the DSN access token module **142**, a plurality of sets of at least a threshold number of DS error coding function slices **270** from the DSN memory **22**. The retrieve DS error coding function slices module **292** includes a send access request module **298**, a send read module **300**, and a receive slices module **302**.

The send access request module **298** is operable to send the DSN access request **272** regarding the data **274** to the DSN access token module **142**. The send read requests module **300** is operable to send a plurality of sets of the at least a threshold number of DS error coding function slices read requests **276** to the DSN memory **22** via the computing device **14**, wherein the DSN access token module **142** determines the DS error coding function **278** in response to the DSN access request **272** (e.g., a based on one or more of a lookup, a computing device identifier, and an identifier of the data **274**), determines DSN storage information for the DS error coding function **278** (e.g., a DSN address corresponding to storage of the DS error coding function **278**), and generates the plurality of sets of at least a threshold number of DS error coding function slice read requests **276** based on the DSN storage information (e.g., the requests include the DSN address corresponding to the storage of the DS error coding function **278**). The receive slices module **302** is operable to receive the plurality of sets of the at least a threshold number of DS error coding function slices **270** from the DSN memory **22**.

The decode slices module **294** is operable to decode, in accordance with decoding responsibilities **308** received from the DSN access token module, at least a portion of the plurality of sets of the at least a threshold number of DS error coding function slices **270** using a default DS error coding function to recapture at least a portion of a DS error coding function **278**. The execute coding function module **296** is operable to execute, in accordance with executing respon-

sibilities **310** received from the DSN access token module **142**, at least a portion of the DS error coding function **278** to access the DSN memory **22** regarding the data **274**.

The execute coding function module **296** is further operable to access the DS error coding function **278** from memory of the DSN access token module **142** for execution of the at least a portion of the DS error coding function **278** to access the DSN memory **22** regarding the data **274**. The execute coding function module **296** is further operable to, when the accessing of the DSN **22** is regarding a data retrieval request, to for a set of a plurality of sets of the at least a threshold number of data slices read requests **280**, send the set of the at least a threshold number of data slices read requests **280** to the DSN memory **22**; receive at least a threshold number of data slices **282** (e.g., read slices) from the DSN memory **22**; and decode, in accordance with the executing responsibilities **310**, the at least a threshold number of data slices **282** in accordance with the DS error coding function **278** to produce a decoded data segment **312**.

The execute coding function module **296** is further operable to, when the accessing of the DSN **22** is regarding a data write request, to encode, in accordance with the executing responsibilities **310**, at least a portion of the data **274** using the DS error coding function **278** to produce one or more sets of encoded data slices **284**; generate, in accordance with the executing responsibilities **310**, storage information regarding the one or more sets of encoded data slices **284**; and send, in accordance with the executing responsibilities **310**, the one or more sets of encoded data slices **284** in accordance with the storage information to the DSN memory **22** for storage therein.

FIG. **11C** is a flowchart illustrating an example of acquiring dispersed storage processing software. The method begins at step **320** where a computing device (e.g., a user device) determines that dispersed storage network (DSN) memory is to be accessed regarding data. The determining may include one of determining that the accessing of the DSN is regarding a data retrieval request and determining that the accessing of the DSN is regarding a data write request.

The method continues at step **322** where a DSN access token module manages a pairing between the DSN access token module and the computing device by at least one of authenticating one or more of a vault identifier (ID) of the DSN memory associated with the computing device, an object number associated with the computing device, an access credential of the computing device, a key of the computing device, a user device ID associated with the computing device, and a password associated with the computing device; determining whether the DSN access token module is actively paired to the computing device and, when the DSN access token module is not actively paired to the computing device, facilitating pairing of the DSN access token module to the computing device; and receiving DS processing feature information (e.g., a capability, a performance level, available software information, hardware configuration information) from the computing device, determining sharing of the decoding of the plurality of sets of the at least a threshold number of DS error coding function slices between the computing device and the DSN access token module based on the DS processing feature information, and determining sharing of the executing of the DS error coding function to access the DSN memory regarding the data between the computing device and the DSN access token module based on the DS processing feature information.

25

A method continues at step **324** where the DSN access token module retrieves a plurality of sets of at least a threshold number of dispersed storage (DS) error coding function slices from the DSN memory via the computing device when the computing device is paired with a DSN access token module. The retrieving the plurality of sets of the at least a threshold number of DS error coding function slices further includes sending, by the computing device, a DSN access request regarding the data to the DSN access token module; determining, by the DSN access token module, the DS error coding function in response to the DSN access request; determining, by the DSN access token module, DSN storage information for the DS error coding function; generating, by the DSN access token module, a plurality of sets of at least a threshold number of DS error coding function slice read requests based on the DSN storage information; sending, by the DSN access token module, the plurality of sets of the at least a threshold number of DS error coding function slices read requests to DSN memory via the computing device; and receiving, by the DSN access token module, the plurality of sets of the at least a threshold number of DS error coding function slices from the DSN memory via the computing device.

The method continues at step **326** where one or more of the computing device and the DSN access token module decodes the plurality of sets of the at least a threshold number of DS error coding function slices using a default DS error coding function (e.g., predetermined function, predetermined dispersal parameters) to recapture a DS error coding function. The method continues at step **328** where the DSN access token module stores the DS error coding function in memory of the DSN access token module.

The method continues at step **330** where the one or more of the computing device and the DSN access token module access the DS error coding function from the memory of the DSN access token module for execution. The method continues at step **332** where the one or more of the computing device and the DSN access token module executes the DS error coding function to access the DSN memory regarding the data.

The method continues at step **334** when the accessing of the DSN is regarding a data retrieval request, the executing the DS error coding function to access the DSN memory regarding the data includes generating a plurality of sets of at least a threshold number of data slice read requests in response to the data retrieval request and for a set of the plurality of sets of the at least a threshold number of data slices read requests sending, by the computing device, the set of the at least a threshold number of data slices read requests to the DSN memory, receiving, by the computing device, at least a threshold number of data slices from the DSN memory, and decoding the at least a threshold number of data slices in accordance with the DS error coding function to produce a decoded data segment.

The method continues at step **336** when the accessing of the DSN is regarding a data write request, the executing the DS error coding function to access the DSN memory regarding the data includes encoding at least a portion of the data using the DS error coding function to produce one or more sets of encoded data slices, generating storage information regarding the one or more sets of encoded data slices, and sending, by the computing device, the one or more sets of encoded data slices in accordance with the storage information to the DSN memory for storage therein. The method continues at step **338** when execution of the DSN error coding function to access the DSN memory regarding the

26

data is complete, deleting, by the DSN access token module, the DSN error coding function from the memory of the DSN access token module.

FIG. **12** is a flowchart illustrating an example of redistributing dispersed storage network (DSN) access information, which includes similar steps to FIG. **7**. The method begins with steps **132**, **136**, and **138** of FIG. **7** where a processing module (e.g., of a user device) retrieves secure token information from a DSN access token module, obtains dispersed storage (DS) processing software, and extracts DSN access information from the secure token information. The retrieving the secure token information may include sending a secure token information request message to the DSN access token module prior to receiving the secure token information. The sending of the secure token information request message may be based on receiving a DSN access information request from at least one other user device.

The method continues at step **340** where the processing module determines whether to distribute the DSN access information and the DS processing software based on the secure token information. For example, the processing module extracts DSN access information redistribution permissions from the secure token information to determine whether redistribution is allowed. The method branches to step **344** when the processing module determines to redistribute. The method continues to step **342** when the processing module determines not to redistribute. The method ends at step **342**.

The method continues at step **344** where the processing module determines the user device distribution list when the processing module determines to redistribute the DSN access information and the DS processing software. The determination may be based on one or more an allowed user device identifier (ID) list extracted from the secure token information, a disallowed user device ID list extracted from the secure token information, a redistribution maximum number of user devices, an actual redistribution number of user devices, and affiliated user device list, a predetermination, a query, and a message. For example, the processing module selects user device IDs from an affiliated user device list that includes user device IDs associated with user devices of a common affiliation (e.g., a family, friends, a coworker group, people in a common building, a neighborhood, a city, a county, a parish, a tribal territory, a state, province, a country, user devices of a similar status and/or location). The method continues at step **346** where the processing module sends the DSN access information and the DS processing software to each user device of the user device distribution list.

FIG. **13A** is a schematic block diagram of another embodiment of a computing system that includes a user device **14** (e.g., a computing device), a network **24**, a digital content provider **352** (e.g., including a content server **106** of FIG. **6**), and a dispersed storage network (DSN) pre-paid module **350**. The DSN pre-paid module **350** includes an interface module **30** for interfacing with the computing device **14**, a memory **144**, and a processing module **50** operably coupled to the memory **144**. The interface module **30** includes at least one of a universal serial bus (USB) interface module, a Bluetooth interface module, a fire-wire interface module, a 60 GHz wireless transceiver, and a Wi-Fi interface module.

When the DSN pre-paid module **350** is paired with a computing device **14**, the processing module **50** is operable to receive, from the computing device **14**, a request **354** to use the DSN pre-paid module **350** to acquire digital content

356 from the digital content provider 352; validate the request 354 to acquire the digital content 356; and when the request 354 to acquire the digital content 356 is validated, generate a plurality of sets of at least a threshold number of digital content read requests 358; send the plurality of sets of the at least a threshold number of digital content read requests 358 to the digital content provider 352 via the computing device 14; receive, in conjunction with (e.g., one of or both) the computing device 14, a plurality of sets of at least a decoded threshold number of encoded data slices 360; and decode, in conjunction with the computing device 14, the plurality of sets of the at least a decoded threshold number of encoded data slices 360 to produce the digital content 356. The processing module 50 is further operable to validate the request 354 to acquire the digital content by validating identity of the digital content provider 352 by at least one of determining that locally stored digital content provider identification information includes the identity of the digital content provider 352, and transceiving, via the computing device 14, a validation process to link the DSN pre-paid module 350 with the digital content provider 352.

The processing module 50 is further operable to send a storage location request 362 to the digital content provider 352 via the computing device 14, wherein the storage location request 362 is requesting information 363 regarding at least one of where the digital content 356 is stored and how the digital content 356 is stored; or access local memory 144 to determine the information 364 regarding the at least one of where the digital content 356 is stored and how the digital content 356 is stored; and generate the plurality of sets of at least a threshold number of digital content read requests 358 in accordance with the information 364 regarding the at least one of where the digital content 356 is stored and how the digital content 356 is stored. The processing module 50 is further operable to validate the request 354 to acquire the digital content by accessing a pre-paid file (e.g., from the local memory 144, from the digital content provider 352) that includes one or more of available credit, expiration criteria, identity of digital content that can be acquired, an identity of the digital content provider, and verifying that the request 354 is compliant with information of the pre-paid file.

The processing module 50 is further operable to, prior to generating the plurality of sets of the at least a threshold number of digital content read requests 358, to generate a set of credential read requests 366 to retrieve acquisition credentials 368; send the set of credential read requests 366 to the digital content provider 352 via the computing device 14; obtain, in conjunction the computing device 14, at least a threshold number of credential slices 370; decode, in conjunction with the computing device 14, the at least a threshold number of credential slices 370 to produce the acquisition credentials 368; and verify, in conjunction with the computing device 14, that the request 354 to acquire the digital content 356 is in accordance with the acquisition credentials 368. The processing module 50 is further operable to obtain the at least a threshold number of credential slices 370 by at least one of retrieving at least one of the at least a threshold number of credential slices 370 from local memory 144 of the DSN pre-paid module 350 and receiving at least some of the at least a threshold number of credential slices 370 from the digital content provider 352.

FIG. 13B is a flowchart illustrating an example of accessing a content server. The method begins at step 372 where, when a computing device is paired with a distributed storage network (DSN) pre-paid module, the computing device receives a request to use the DSN pre-paid module to acquire

digital content from a digital content provider. The digital content includes one or more of a specific digital content and a plurality of digital content, wherein the digital content includes a live content stream, a content file, a video file, an audio file, a video-on-demand, and audio books. The method continues at step 374 where the computing device forwards the request to the DSN pre-paid module.

The method continues at step 376 where the DSN pre-paid module validates the request to acquire the digital content. The validating the request to acquire the digital content further includes validating the identity of the digital content provider by at least one of determining that locally stored digital content provider identification information includes the identity of the digital content provider and transceiving, via the computing device, a validation process to link the DSN pre-paid module with the digital content provider. The validating the request to acquire the digital content further includes accessing a pre-paid file that includes one or more of: available credit, expiration criteria (e.g., expires in one month, expires after three views), identity of digital content that can be acquired (e.g., specific digital content), an identity of the digital content provider, and verifying that the request is compliant with information of the pre-paid file.

The method continues at step 378, when the request to acquire the digital content is validated, where the DSN pre-paid module generates a set of credential read requests to retrieve acquisition credentials. The acquisition credentials includes one or more of a signed certificate, an access credential, a key, a content server address, a content server internet protocol (IP) address, a vault identifier (ID), a source name, a slice name, a data segmentation approach, and dispersal parameters. The method continues at step 380 where the DSN pre-paid module sends the set of credential read requests to the digital content provider via the computing device.

The method continues at step 382 where at least one of the DSN pre-paid module and the computing device obtains at least a threshold number of credential slices. The obtaining the at least a threshold number of credential slices includes at least one of: retrieving at least one of the at least a threshold number of credential slices from local memory of the DSN pre-paid module and receiving at least some of the at least a threshold number of credential slices from the digital content provider. The method continues at step 384 where at least one of the DSN pre-paid module and the computing device decodes the at least a threshold number of credential slices to produce the acquisition credentials. The method continues at step 386 where at least one of the DSN pre-paid module and the computing device verifies that the request to acquire the digital content is in accordance with the acquisition credentials.

The method continues at step 388 where the DSN pre-paid module generates a plurality of sets of at least a threshold number of digital content read requests. The generating includes at least one of obtaining a signed certificate, obtaining information regarding where the digital content is stored, and obtaining information regarding how the digital content is stored. For example, the DSN pre-paid module sends a storage location request to the digital content provider via the computing device, wherein the storage location request is requesting information regarding at least one of where the digital content is stored and how the digital content is stored or accesses local memory to determine the information regarding the at least one of where the digital content is stored and how the digital content is stored and generates plurality of sets of at least a threshold number of

digital content read requests in accordance with the information regarding the at least one of where the digital content is stored and how the digital content is stored.

The obtaining the signed certificate includes at least one of retrieving a DSN pre-paid module signed certificate as the signed certificate, wherein the DSN pre-paid module signed certificate was signed by the DSN pre-paid module; retrieving a digital content provider signed certificate as the signed certificate, wherein the digital content provider signed certificate was signed by the digital content provider; receiving the signed certificate from the digital content provider; and signing a certificate of the DSN pre-paid module to produce the signed certificate.

The method continues at step 390 where the DSN pre-paid module sends the plurality of sets of the at least a threshold number of digital content read requests to the digital content provider via the computing device. The method continues at step 392 where at least one of the DSN pre-paid module and the computing device receives a plurality of sets of at least a decoded threshold number of encoded data slices. The method continues at step 394 where at least one of the DSN pre-paid module and the computing device decodes the plurality of sets of the at least a decoded threshold number of encoded data slices to produce the digital content. The method continues at step 396 where the DSN pre-paid module updates the pre-paid file (e.g., lowering available credits).

FIG. 13C is a flowchart illustrating an example of providing content, which includes similar steps to FIG. 13B. The method begins with steps 372 and 376 of FIG. 13B where a processing module (e.g., of a digital content provider) receives (e.g., from a computing device) a request to use a dispersed storage network (DSN) pre-paid module to acquire digital content from the digital content provider and validates the request to acquire the digital content. When the request to acquire the digital content is validated, the method continues at step 404 where the processing module receives a plurality of sets of at least a threshold number of digital content read requests. The method continues at step 406 where the processing module accesses a set of dispersed storage (DS) units to retrieve a plurality of sets of at least a decoded threshold number of encoded data slices, wherein the digital content is stored as a plurality of sets of encoded data slices in accordance with a DS error coding function. The method continues at step 408 where the processing module sends the plurality of sets of the at least a decoded threshold number of encoded data slices to the computing device.

FIG. 14 is a flowchart illustrating an example of retrieving secure information, which includes similar steps to FIG. 7. The method begins with step 132 of FIG. 7 where a processing module (e.g., of a user device) retrieves secure token information from a dispersed storage network (DSN) access token. The method continues at step 410 where the processing module retrieves a plurality of sets of encoded data slices from a DSN memory in accordance with the secure token information. For example, the processing module extracts a source name from the secure token information and determines a plurality of sets of slice names in accordance with the source name. Next, the processing module sends a plurality of slice retrieval request messages to the DSN memory utilizing a DSN address of the secure token information, wherein the plurality of slice retrieval request messages include one or more of the plurality of sets of slice names, a user device identifier (ID), credential information extracted from the secure token information, and a password. Next, the processing module receives the

plurality of sets of encoded data slices from the DSN memory in response to sending the plurality of request messages.

The method continues at step 412 where the processing module stores the plurality of sets of encoded data slices in a persistent memory in accordance with the secure token information. The secure token information includes slice storage rights, wherein such storage rights includes one or more of an allowed storage time duration by slice name, an allowed memory type indicator (e.g., persistent memory, non-persistent memory), a number of allowed slices indicator, an allowed segment ID, an allowed storage time duration data corresponding to the plurality of sets of encoded data slices, an amount of allowed data indicator, an allow data portion indicator, an allowed data type indicator, and an allowed pillar ID. For example, processing module stores a set of encoded data slices corresponding to segment 457 in the persistent memory when the allowed segment ID corresponds to segment 457 and the allowed memory type indicator indicates persistent memory is allowed.

The method continues at step 414 where the processing module dispersed storage error decodes the plurality of sets of encoded data slices in accordance with the secure token information to produce data. For example, the processing module dispersed storage error decodes the plurality of sets of encoded data slices utilizing dispersed storage error coding parameters of the secure token information to produce data. The method continues at step 416 where the processing module stores the data in a non-persistent memory in accordance with the secure token information. For example, the processing module stores the data in the non-persistent memory when the amount of allowed data indicator indicates 100% of the data and the allowed memory type indicator indicates non-persistent memory is allowed.

As may be used herein, the terms “substantially” and “approximately” provides an industry-accepted tolerance for its corresponding term and/or relativity between items. Such an industry-accepted tolerance ranges from less than one percent to fifty percent and corresponds to, but is not limited to, component values, integrated circuit process variations, temperature variations, rise and fall times, and/or thermal noise. Such relativity between items ranges from a difference of a few percent to magnitude differences. As may also be used herein, the term(s) “operably coupled to”, “coupled to”, and/or “coupling” includes direct coupling between items and/or indirect coupling between items via an intervening item (e.g., an item includes, but is not limited to, a component, an element, a circuit, and/or a module) where, for indirect coupling, the intervening item does not modify the information of a signal but may adjust its current level, voltage level, and/or power level. As may further be used herein, inferred coupling (i.e., where one element is coupled to another element by inference) includes direct and indirect coupling between two items in the same manner as “coupled to”. As may even further be used herein, the term “operable to” or “operably coupled to” indicates that an item includes one or more of power connections, input(s), output(s), etc., to perform, when activated, one or more its corresponding functions and may further include inferred coupling to one or more other items. As may still further be used herein, the term “associated with”, includes direct and/or indirect coupling of separate items and/or one item being embedded within another item. As may be used herein, the term “compares favorably”, indicates that a comparison between two or more items, signals, etc., provides a desired relationship. For example, when the desired relationship is that

signal 1 has a greater magnitude than signal 2, a favorable comparison may be achieved when the magnitude of signal 1 is greater than that of signal 2 or when the magnitude of signal 2 is less than that of signal 1.

As may also be used herein, the terms “processing module”, “processing circuit”, and/or “processing unit” may be a single processing device or a plurality of processing devices. Such a processing device may be a microprocessor, micro-controller, digital signal processor, microcomputer, central processing unit, field programmable gate array, programmable logic device, state machine, logic circuitry, analog circuitry, digital circuitry, and/or any device that manipulates signals (analog and/or digital) based on hard coding of the circuitry and/or operational instructions. The processing module, module, processing circuit, and/or processing unit may be, or further include, memory and/or an integrated memory element, which may be a single memory device, a plurality of memory devices, and/or embedded circuitry of another processing module, module, processing circuit, and/or processing unit. Such a memory device may be a read-only memory, random access memory, volatile memory, non-volatile memory, static memory, dynamic memory, flash memory, cache memory, and/or any device that stores digital information. Note that if the processing module, module, processing circuit, and/or processing unit includes more than one processing device, the processing devices may be centrally located (e.g., directly coupled together via a wired and/or wireless bus structure) or may be distributedly located (e.g., cloud computing via indirect coupling via a local area network and/or a wide area network). Further note that if the processing module, module, processing circuit, and/or processing unit implements one or more of its functions via a state machine, analog circuitry, digital circuitry, and/or logic circuitry, the memory and/or memory element storing the corresponding operational instructions may be embedded within, or external to, the circuitry comprising the state machine, analog circuitry, digital circuitry, and/or logic circuitry. Still further note that, the memory element may store, and the processing module, module, processing circuit, and/or processing unit executes, hard coded and/or operational instructions corresponding to at least some of the steps and/or functions illustrated in one or more of the Figures. Such a memory device or memory element can be included in an article of manufacture.

The present invention has been described above with the aid of method steps illustrating the performance of specified functions and relationships thereof. The boundaries and sequence of these functional building blocks and method steps have been arbitrarily defined herein for convenience of description. Alternate boundaries and sequences can be defined so long as the specified functions and relationships are appropriately performed. Any such alternate boundaries or sequences are thus within the scope and spirit of the claimed invention. Further, the boundaries of these functional building blocks have been arbitrarily defined for convenience of description. Alternate boundaries could be defined as long as the certain significant functions are appropriately performed. Similarly, flow diagram blocks may also have been arbitrarily defined herein to illustrate certain significant functionality. To the extent used, the flow diagram block boundaries and sequence could have been defined otherwise and still perform the certain significant functionality. Such alternate definitions of both functional building blocks and flow diagram blocks and sequences are thus within the scope and spirit of the claimed invention. One of average skill in the art will also recognize that the functional building blocks, and other illustrative blocks,

modules and components herein, can be implemented as illustrated or by discrete components, application specific integrated circuits, processors executing appropriate software and the like or any combination thereof.

The present invention may have also been described, at least in part, in terms of one or more embodiments. An embodiment of the present invention is used herein to illustrate the present invention, an aspect thereof, a feature thereof, a concept thereof, and/or an example thereof. A physical embodiment of an apparatus, an article of manufacture, a machine, and/or of a process that embodies the present invention may include one or more of the aspects, features, concepts, examples, etc. described with reference to one or more of the embodiments discussed herein. Further, from figure to figure, the embodiments may incorporate the same or similarly named functions, steps, modules, etc. that may use the same or different reference numbers and, as such, the functions, steps, modules, etc. may be the same or similar functions, steps, modules, etc. or different ones.

While the transistors in the above described figure(s) is/are shown as field effect transistors (FETs), as one of ordinary skill in the art will appreciate, the transistors may be implemented using any type of transistor structure including, but not limited to, bipolar, metal oxide semiconductor field effect transistors (MOSFET), N-well transistors, P-well transistors, enhancement mode, depletion mode, and zero voltage threshold (VT) transistors.

Unless specifically stated to the contra, signals to, from, and/or between elements in a figure of any of the figures presented herein may be analog or digital, continuous time or discrete time, and single-ended or differential. For instance, if a signal path is shown as a single-ended path, it also represents a differential signal path. Similarly, if a signal path is shown as a differential path, it also represents a single-ended signal path. While one or more particular architectures are described herein, other architectures can likewise be implemented that use one or more data buses not expressly shown, direct connectivity between elements, and/or indirect coupling between other elements as recognized by one of average skill in the art.

The term “module” is used in the description of the various embodiments of the present invention. A module includes a processing module, a functional block, hardware, and/or software stored on memory for performing one or more functions as may be described herein. Note that, if the module is implemented via hardware, the hardware may operate independently and/or in conjunction software and/or firmware. As used herein, a module may contain one or more sub-modules, each of which may be one or more modules.

While particular combinations of various functions and features of the present invention have been expressly described herein, other combinations of these features and functions are likewise possible. The present invention is not limited by the particular examples disclosed herein and expressly incorporates these other combinations.

What is claimed is:

1. A method comprises:

receiving, by a computing device that is paired with a distributed storage network (DSN) pre-paid module, a request to use the DSN pre-paid module to acquire digital content from a digital content provider, wherein the digital content is dispersed storage error encoded into a plurality of sets of encoded data slices that are stored in storage units of the digital content provider, wherein the storage units are separate devices from the computing device;



forwarding, by the computing device, the request to the DSN pre-paid module;  
determining, by the DSN pre-paid module, whether payment for the digital content has been previously authorized by:  
5 accessing a pre-paid file that includes one or more of: available credit, expiration criteria, identity of digital content that can be acquired, and identity of the digital content provider; and  
verifying that the request is compliant with the pre-paid file;  
10 in response to determining the request is compliant with the pre-paid file, generating, by the DSN pre-paid module, a set of credential read requests to retrieve acquisition credentials;  
sending, by the DSN pre-paid module, the set of credential read requests to the digital content provider via the computing device;  
obtaining, by at least one of the DSN pre-paid module and the computing device, at least a threshold number of credential slices;  
20 decoding, by the at least one of the DSN pre-paid module and the computing device, the at least a threshold number of credential slices to produce the acquisition credentials;  
and verifying, by the at least one of the DSN pre-paid module and the computing device, that the request to acquire the digital content is in accordance with the acquisition credentials;  
30 in response to a determination that the request to acquire the digital content is in accordance with the acquisition credentials, generating, by the DSN pre-paid module, a plurality of sets of at least a threshold number of digital content read requests regarding the plurality of sets of encoded data slices, wherein each encoded data slice of the plurality of sets of encoded data slices is associated with a slice name and each of the at least a threshold number of digital content read requests includes a slice name for an encoded data slice of the plurality of sets of encoded data slices;  
40 sending; by the DSN pre-paid module, the plurality of sets of the at least a threshold number of digital content read requests to the storage units of the digital content provider via the computing device;  
receiving, by at least one of the DSN pre-paid module and the computing device, at least a decoded threshold number of encoded data shoes of at least some of the sets of the plurality of sets of encoded data shoes;  
45 and decoding, by the at least one of the DSN pre-paid module and the computing device, the at least a decoded threshold number of encoded data shoes of the at least some of the sets of the plurality of sets of encoded data shoes to produce the digital content.  
2. The method of claim 1 further comprises: sending, by the DSN pre-paid module; a storage location request to the digital content provider via the computing device, wherein the storage location request is requesting information regarding at least one of where the digital content is stored and how the digital content is stored; or accessing, by the DSN pre-paid module, local memory to determine the information regarding the at least one of where the digital content is stored and how the digital content is stored; and  
60 generating, by the DSN pre-paid module, the plurality of sets of at least a threshold number of digital content read requests in accordance with the information regarding the at least one of where the digital content is stored and how the digital content is stored.  
65

3. The method of claim 1, wherein the validating the request to acquire the digital content further comprises: validating the identity of the digital content provider by at least one of: determining that locally stored digital content provider identification information includes the identity of the digital content provider; and transceiving, via the computing device, a validation process to link the DSN pre-paid module with the digital content provider.

4. The method of claim 1, wherein the obtaining the at least a threshold number of credential slices comprises at least one of: retrieving at least one of the at least a threshold number of credential slices from local memory of the DSN pre-paid module; and receiving at least some of the at least a threshold number of credential shoes from the digital content provider.  
15

5. The method of claim 1 further comprises: after the digital content is acquired, updating, by the DSN pre-paid module, the pre-paid file.

6. A dispersed storage network (DSN) pre-paid module that is paired with a computing device, the DSN pre-paid module comprises:

an interface module for interfacing with the computing device;

memory; and

25 a processing module operably coupled to the memory and operable to,

receive, from the computing device, a request to use the DSN pre-paid module to acquire digital content from a digital content provider, wherein the digital content is dispersed storage error encoded into a plurality of sets of encoded data slices that is stored in storage units of the digital content provider, wherein the storage units are separate devices from the computing device;

determine whether payment for the digital content has been previously authorized by:

accessing a pre-paid file that includes one or more of: available credit, expiration criteria, identity of digital content that can be acquired, and identity of the digital content provider; and verifying that the request is compliant with the pre-paid file;

in response to the determination the request is compliant with the pre-paid file, generate, by the DSN pre-paid module, a set of credential read requests to retrieve acquisition credentials;

send, by the DSN pre-paid module, the set of credential read requests to the digital content provider via the computing device;

obtain, by at least one of the DSN pre-paid module and the computing device, at least a threshold number of credential slices;

decode, by the at least one of the DSN pre-paid module and the computing device, the at least a threshold number of credential slices to produce the acquisition credentials;

and verify, by the at least one of the DSN pre-paid module and the computing device, that the request to acquire the digital content is in accordance with the acquisition credentials;

in response to a determination that the request to acquire the digital content is in accordance with the acquisition credentials, generate a plurality of sets of at least a threshold number of digital content read requests regarding the plurality of sets of encoded data slices, wherein each encoded data slice of the plurality of sets of encoded data slices is associated with a slice name and each of

35

the digital content read requests includes a slice name for an encoded data slice of the plurality of sets of encoded data slices; send the plurality of sets of the at least a threshold number of digital content read requests to the storage units of the digital content provider via the computing device; receive, in conjunction with the computing device at least a decoded threshold number of encoded data slices of at least some of the sets of the plurality of sets of encoded data slices; and decode, in conjunction with the computing device, at least a decoded threshold number of encoded data slices of the at least some of the sets of the plurality of sets of encoded data shoes to produce the digital content.

7. The DSN pre-paid module of claim 6, wherein the processing module is further operable to;

send a storage location request to the digital content provider via the computing device, wherein the storage location request is requesting information regarding at least one of where the digital content is stored and how the digital content is stored; or

access local memory to determine the information regarding the at least one of where the digital content is stored and how the digital content is stored; and

36

generate the plurality of sets of at least a threshold number of digital content read requests in accordance with the information regarding the at least one of where the digital content is stored and how the digital content is stored.

8. The DSN pre-paid module of claim 6, wherein the processing module is further operable to validate the request to acquire the digital content by:

validating the identity of the digital content provider by at least one of:

determining that locally stored digital content provider identification information includes the identity of the digital content provider; and

transceiving, via the computing device, a validation process to link the DSN pre-paid module with the digital content provider.

9. The DSN pre-paid module of claim 6, wherein the processing module is further operable to obtain the at least a threshold number of credential slices by at least one of:

retrieving at least one of the at least a threshold number of credential slices from local memory of the DSN pre-paid module; and

receiving at least some of the at least a threshold number of credential slices from the digital content provider.

\* \* \* \* \*