



US010385926B2

(12) **United States Patent**
Kleinfeld et al.

(10) **Patent No.:** **US 10,385,926 B2**
(45) **Date of Patent:** **Aug. 20, 2019**

(54) **VARIABLE STIFFNESS JOINT ASSEMBLY HAVING A BUSHING ASSEMBLY**

USPC 464/173-175, 906; 403/50, 51;
277/634-637

See application file for complete search history.

(71) Applicant: **Steering Solutions IP Holding Corporation**, Saginaw, MI (US)

(56) **References Cited**

(72) Inventors: **Brian J. Kleinfeld**, Saginaw, MI (US);
Jeffrey P. Courville, Frankenmuth, MI (US);
Jon N. Miller, Merrill, MI (US)

U.S. PATENT DOCUMENTS

(73) Assignee: **Steering Solutions IP Holding Corporation**, Saginaw, MI (US)

4,132,422 A *	1/1979	Sankey	F16D 3/227
				277/635
4,240,680 A *	12/1980	Krude	B60B 35/18
				180/259
4,262,498 A *	4/1981	Krude	F16D 3/224
				464/145
5,295,914 A *	3/1994	Milavec	F16D 3/845
				277/636
5,529,538 A *	6/1996	Schulz	F16D 3/845
				464/175

(*) Notice: Subject to any disclaimer, the term of this patent is extended or adjusted under 35 U.S.C. 154(b) by 44 days.

(Continued)

(21) Appl. No.: **15/351,518**

FOREIGN PATENT DOCUMENTS

(22) Filed: **Nov. 15, 2016**

(65) **Prior Publication Data**
US 2018/0135705 A1 May 17, 2018

DE	20121652 U1	2/2003		
FR	2888529 A1 *	1/2007	B60B 27/0005
WO	WO-2013175960 A1 *	11/2013	F16D 3/84

(51) **Int. Cl.**
F16C 17/10 (2006.01)
F16C 33/78 (2006.01)
F16D 3/223 (2011.01)
F16D 3/84 (2006.01)
F16J 3/04 (2006.01)
F16D 3/06 (2006.01)

OTHER PUBLICATIONS

European Search Report for European Application No. 17201355.9 dated Apr. 30, 2018; 7 pages.

Primary Examiner — Josh Skroupa

(52) **U.S. Cl.**
CPC **F16D 3/845** (2013.01); **F16C 17/10** (2013.01); **F16C 33/783** (2013.01); **F16D 3/06** (2013.01); **F16J 3/042** (2013.01); **F16J 3/048** (2013.01); **F16D 3/223** (2013.01); **F16D 2003/22316** (2013.01); **Y10S 464/906** (2013.01)

(57) **ABSTRACT**
A bushing assembly for a variable stiffness joint assembly includes a bushing body. The bushing body is disposed about a shaft assembly. The bushing body has an inner bushing surface, an outer bushing surface that is spaced apart from the inner bushing surface, a first bushing face that extends between a first end of the inner bushing surface and a first end of the outer bushing surface, and a second bushing face that extends between a second end of the inner bushing surface and a second end the outer bushing surface.

(58) **Field of Classification Search**
CPC F16C 17/10; F16C 33/783; F16D 3/845; F16D 2003/22316; F16J 3/042; F16J 3/048; Y10T 403/31; Y10T 403/315

13 Claims, 6 Drawing Sheets

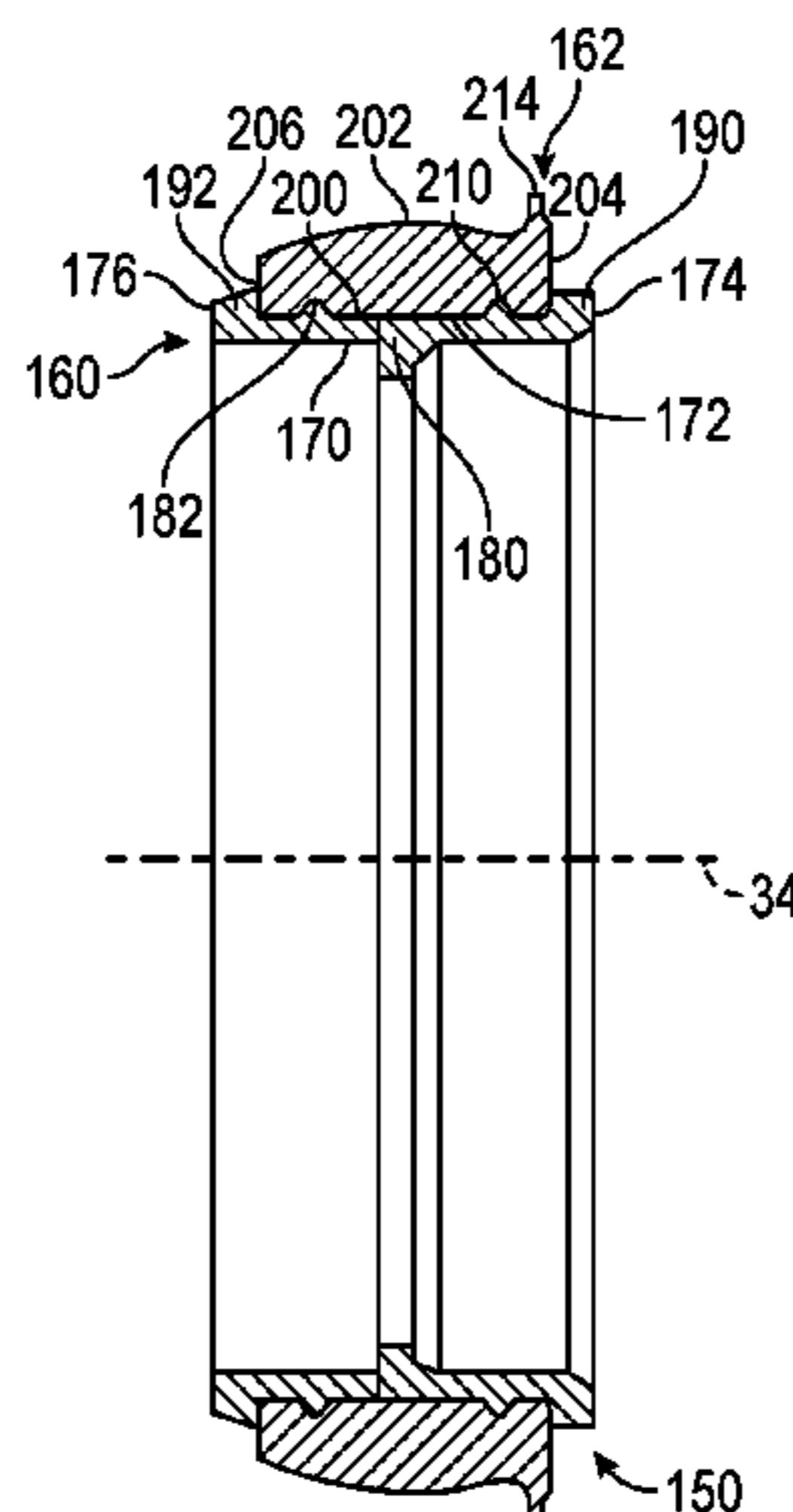

(56)

References Cited

U.S. PATENT DOCUMENTS

6,695,706	B2 *	2/2004	Furuta	F16D 3/845 464/175
7,338,383	B2 *	3/2008	Toriumi	F16D 3/84 464/175
7,712,994	B2 *	5/2010	Cermak	F16D 1/06 403/246
8,246,475	B2 *	8/2012	Kozlowski	F16D 3/221 464/141
8,864,591	B2 *	10/2014	Sugiyama	F16C 1/04 403/359.5
2007/0026953	A1	2/2007	Ohsita et al.	
2011/0059803	A1	3/2011	Kozlowski et al.	

* cited by examiner

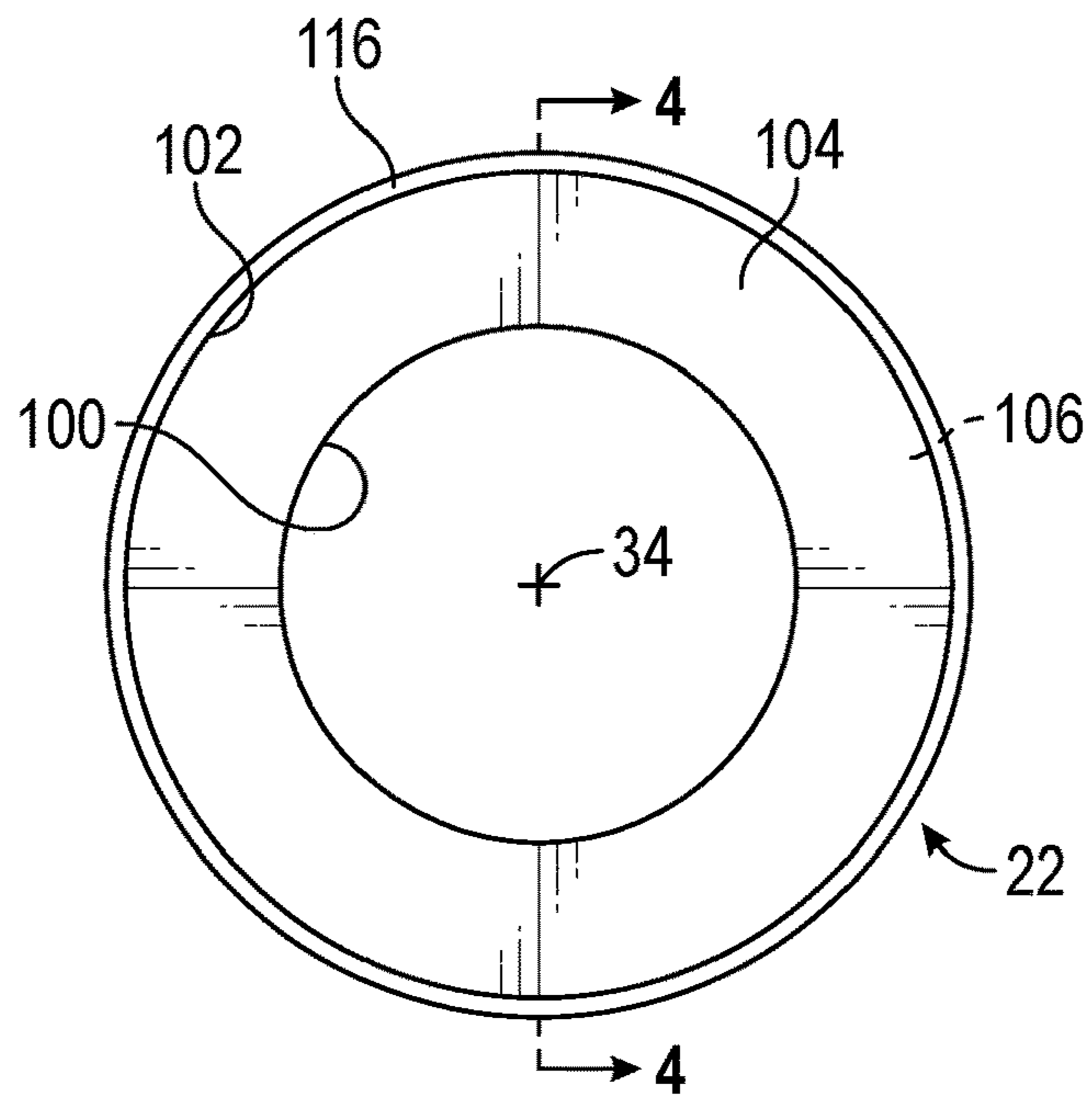

FIG. 3

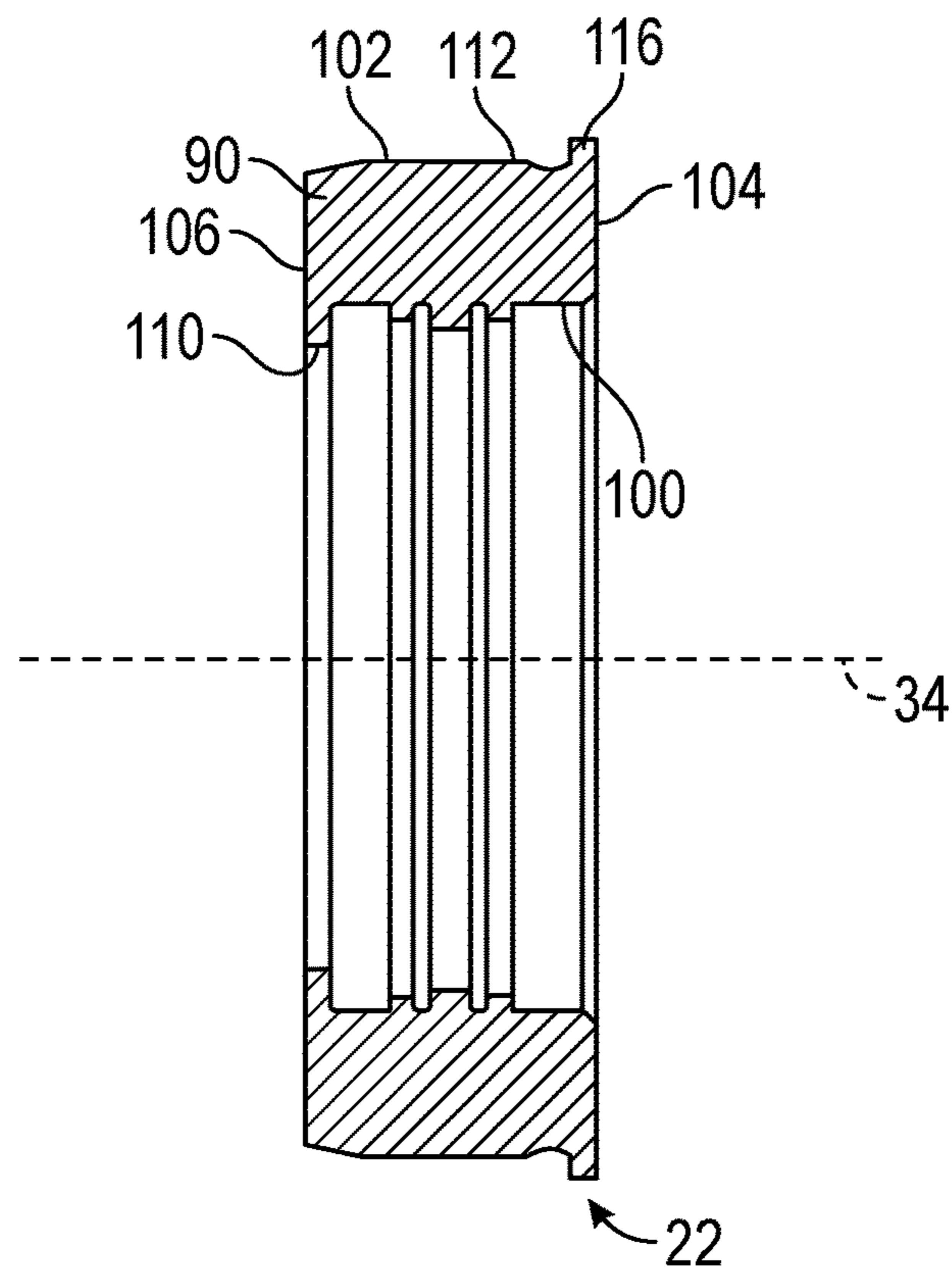

FIG. 4

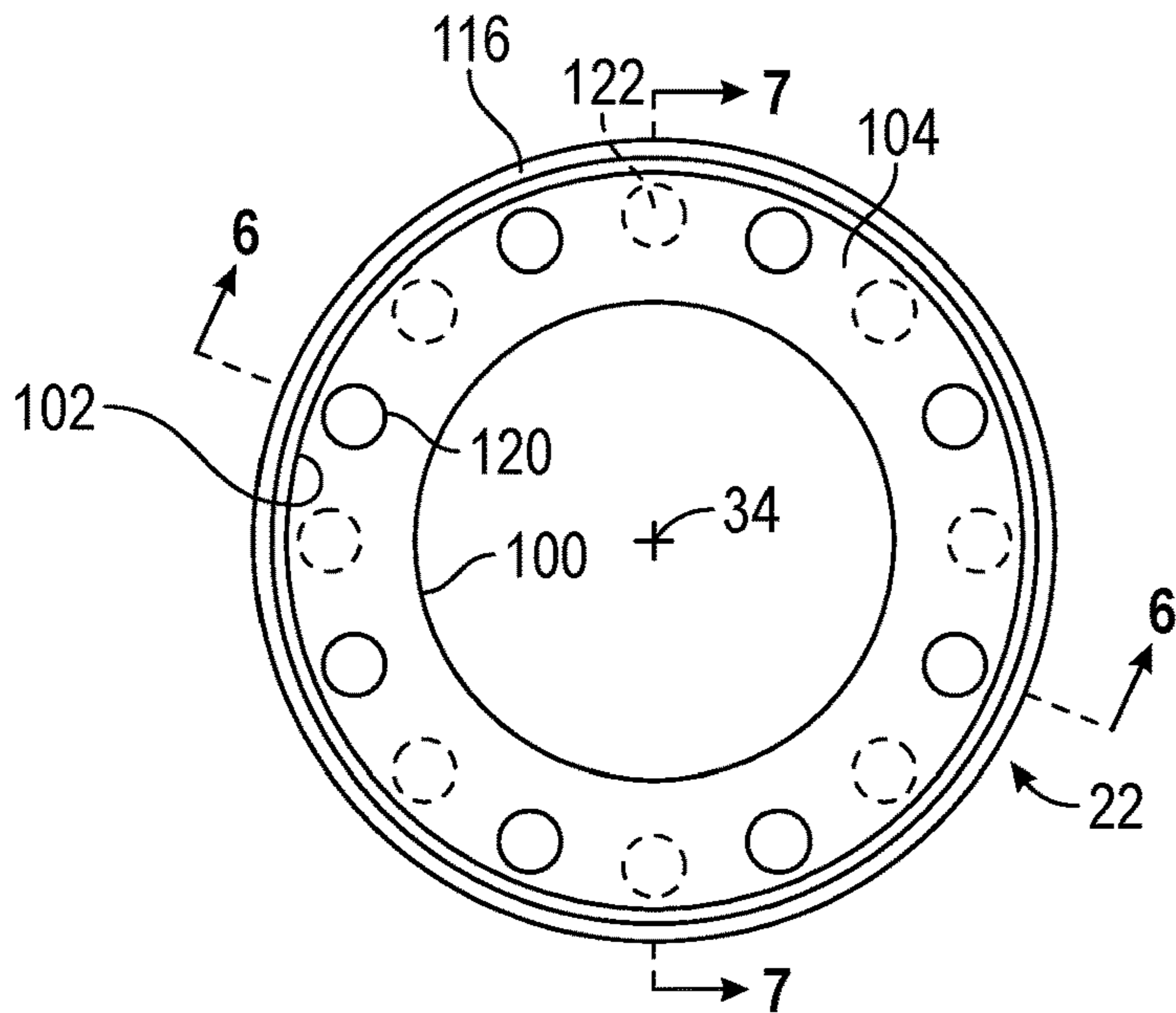

FIG. 5

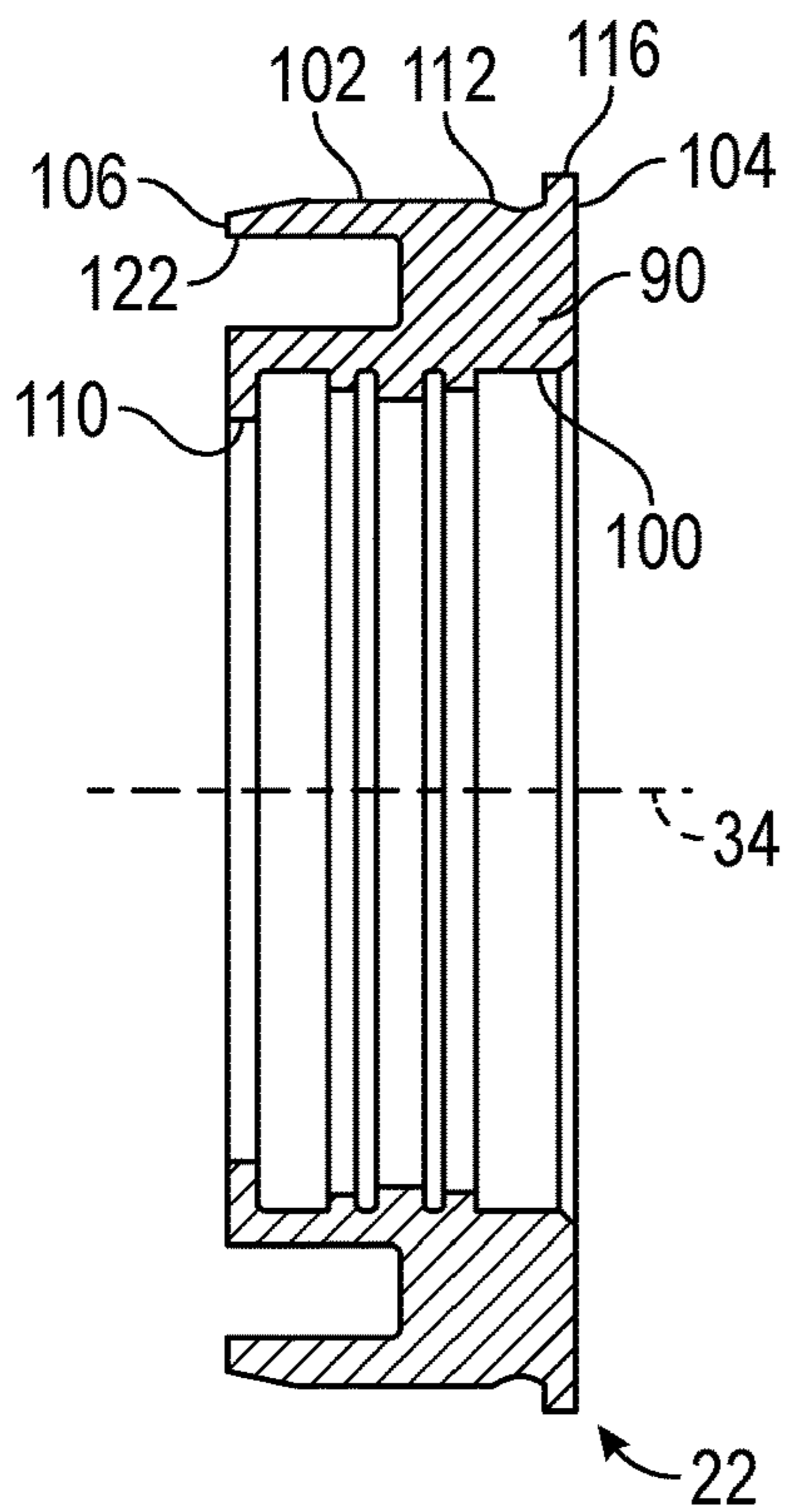

FIG. 6

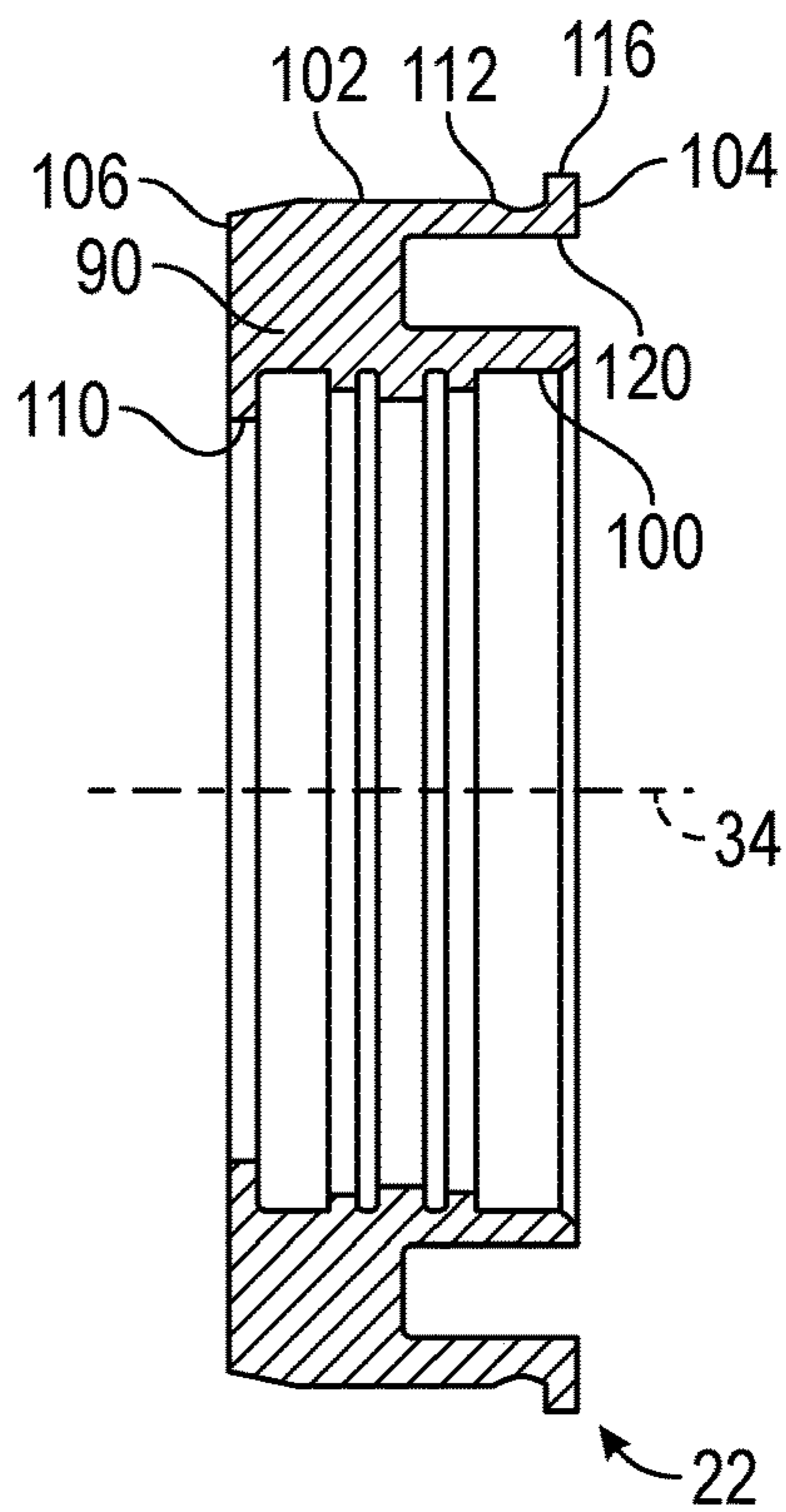

FIG. 7

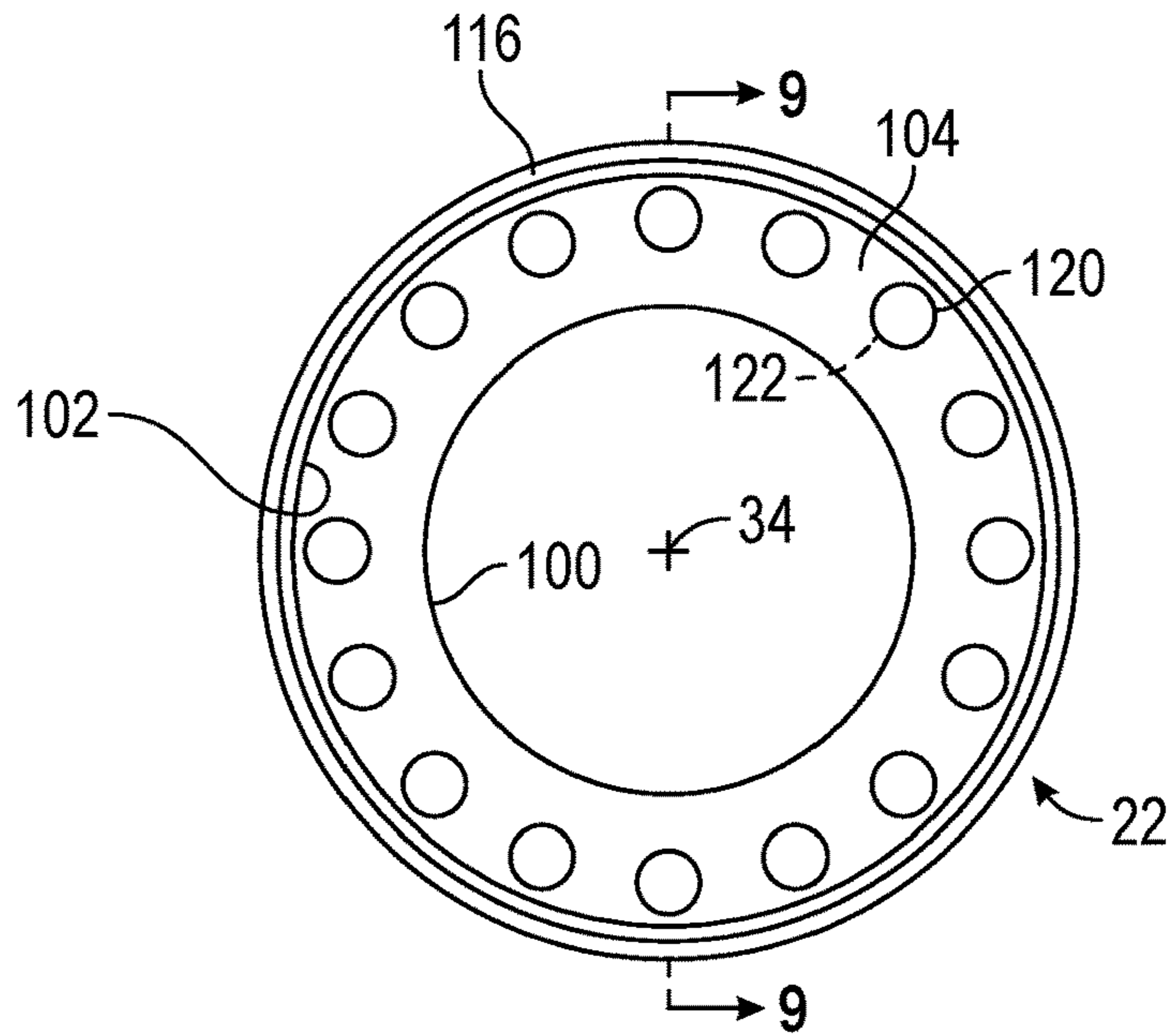

FIG. 8

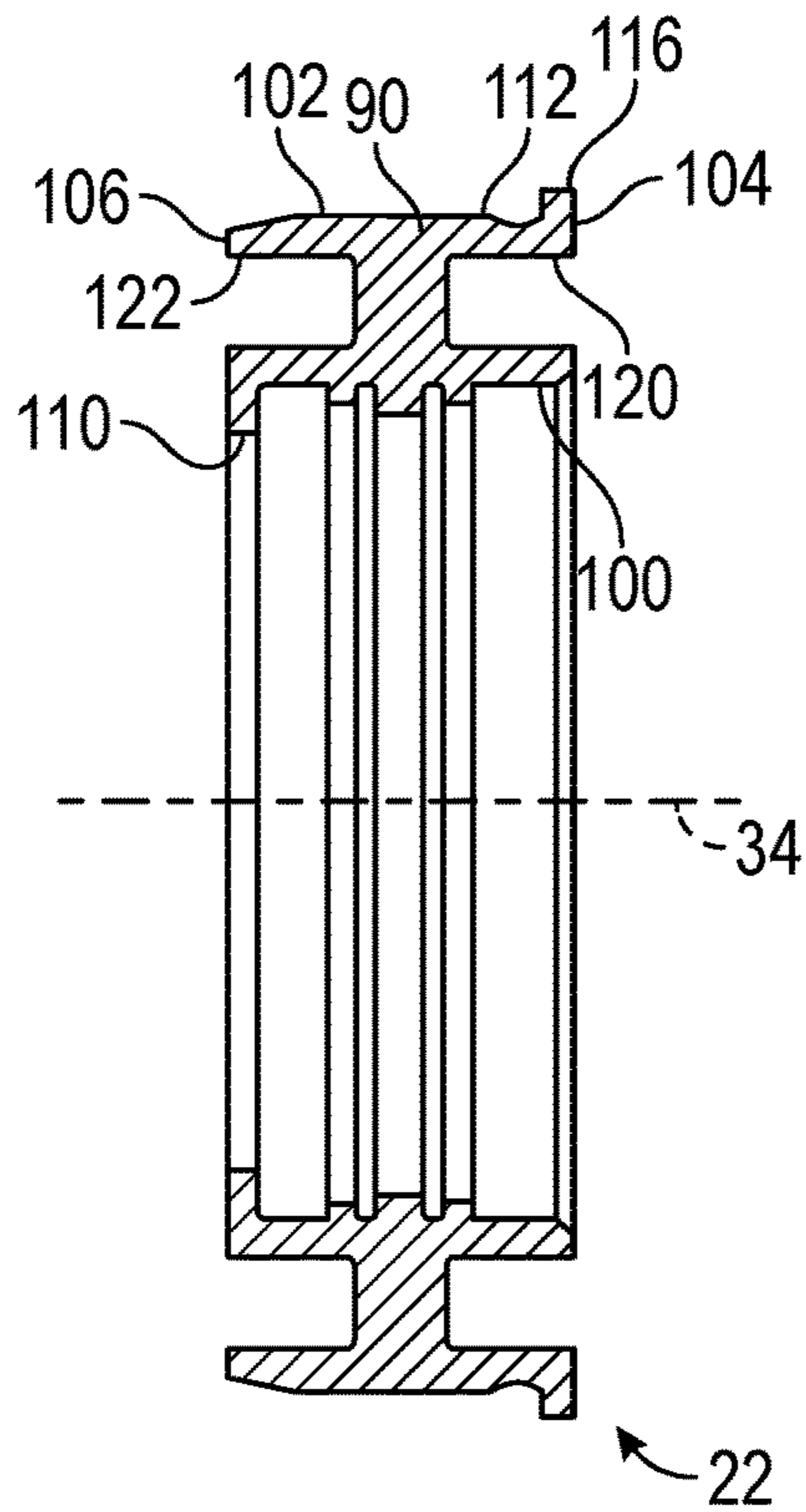

FIG. 9

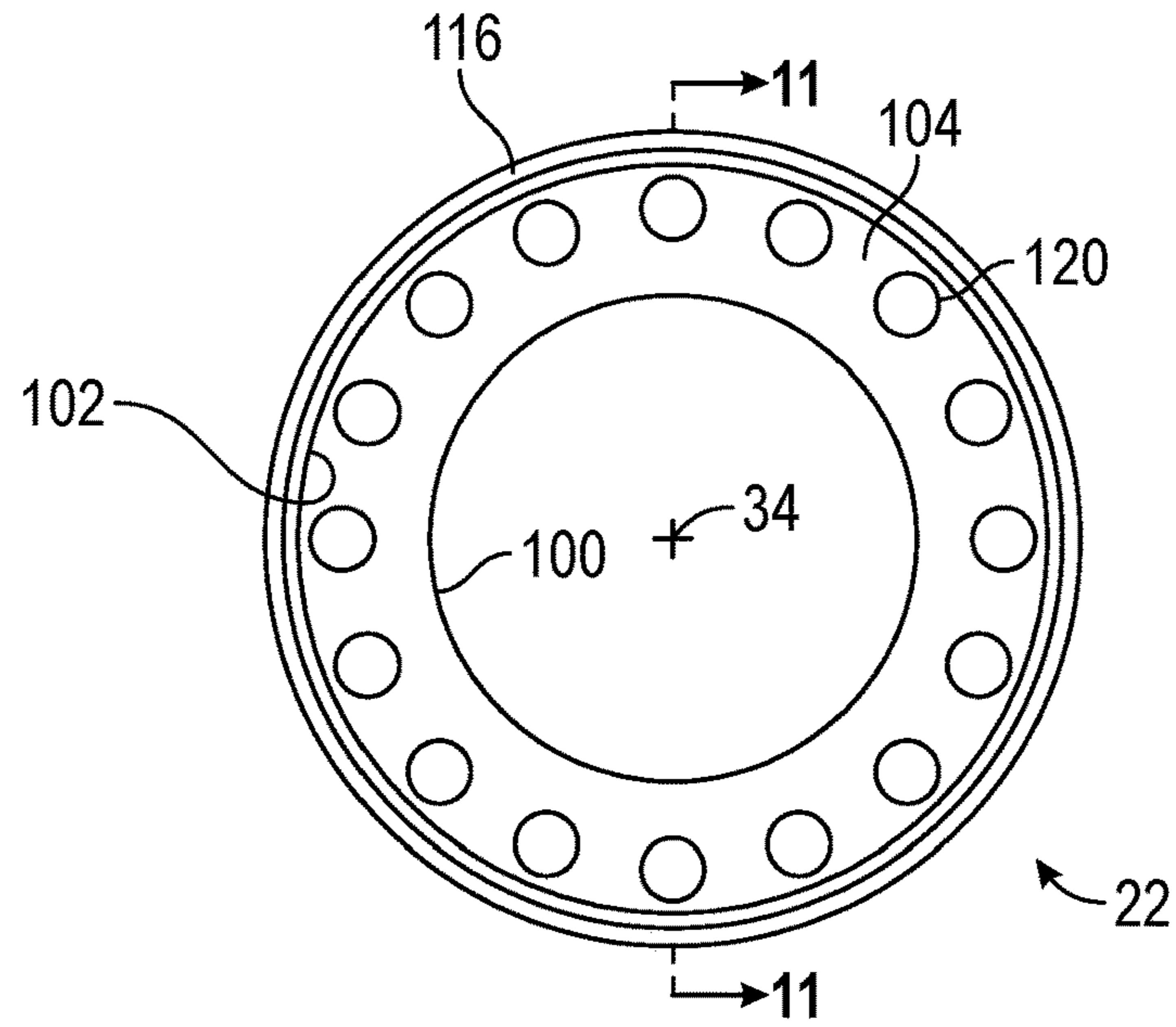

FIG. 10

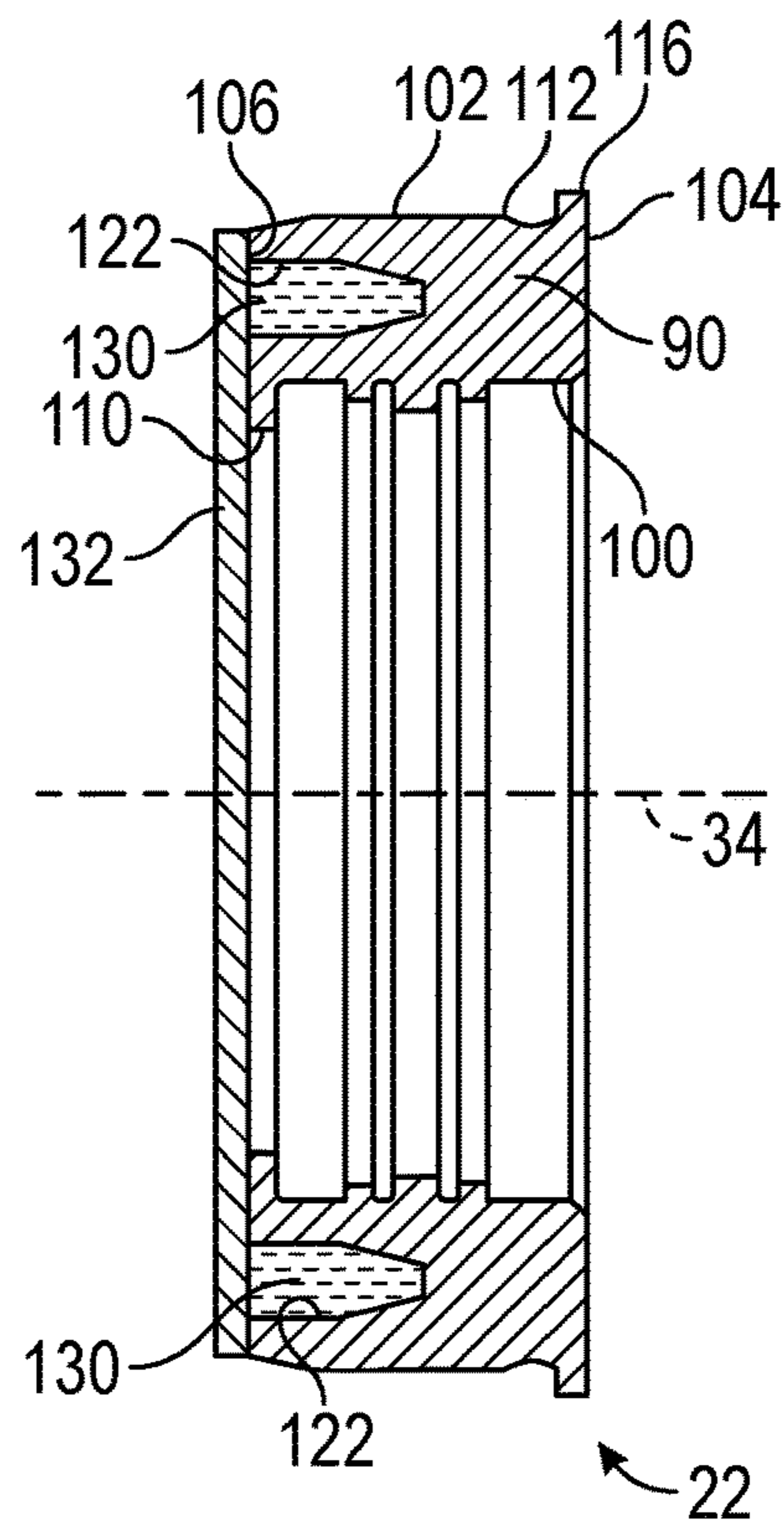

FIG. 11

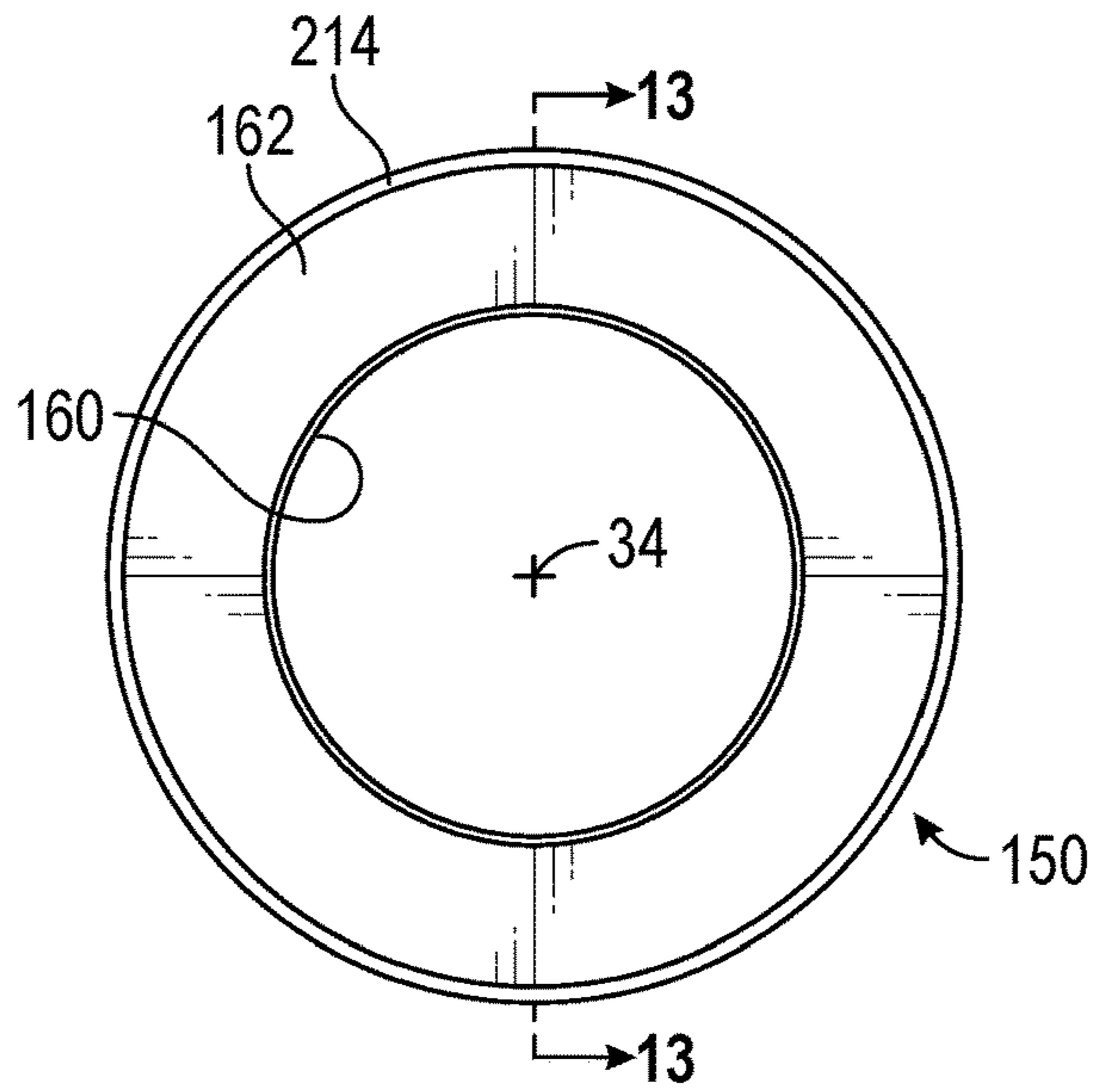

FIG. 12

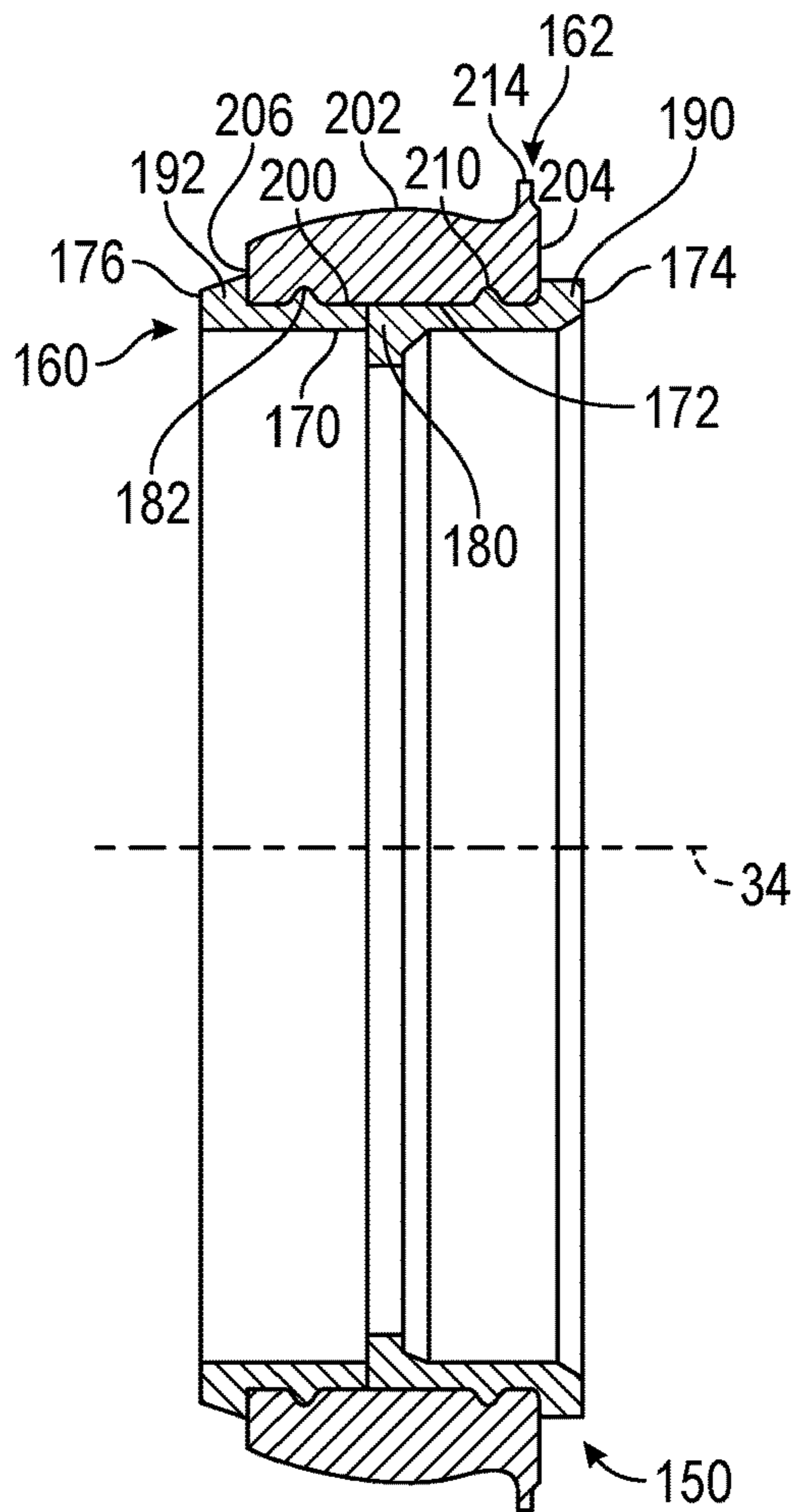

FIG. 13

VARIABLE STIFFNESS JOINT ASSEMBLY HAVING A BUSHING ASSEMBLY

BACKGROUND OF THE INVENTION

A sealing assembly may be provided about a portion of a constant velocity joint to seal lubricant within the constant velocity joint and to exclude foreign objects from entering the constant velocity joint. The sealing assembly may include a first convoluted seal that permits angular and axial displacement of the constant velocity joint and a bushing permits rotational movement of the parts.

SUMMARY OF THE INVENTION

According to an embodiment of the present disclosure, a variable stiffness joint assembly is provided. The variable stiffness joint assembly includes a first member, a second member and a bushing assembly. The first member extends along an axis. The first member has a first outer surface and a first inner surface each extending between a first member first end and a first member second end. The second member extends along the axis and is at least partially received within the first member. The second member has a second outer surface extending between a second member first end and a second member second end that is operatively connected to a constant velocity joint assembly. The bushing assembly is disposed about the first member. The bushing assembly includes a bushing body that extends radially between an inner bushing surface and an outer bushing surface and that extends axially between a first bushing face and a second bushing face. The inner bushing surface is disposed about the first outer surface.

According to another embodiment of the present disclosure, a bushing assembly for a variable stiffness joint assembly is provided. The bushing assembly includes a bushing body and a boot stop. The bushing body is disposed about a shaft assembly. The bushing body has an inner bushing surface, an outer bushing surface that is spaced apart from the inner bushing surface, a first bushing face that extends between a first end of the inner bushing surface and a first end of the outer bushing surface, and a second bushing face that extends between a second end of the inner bushing surface and a second end of the outer bushing surface. The boot stop extends from the bushing body.

According to yet another embodiment of the present disclosure, a bushing assembly for a variable stiffness joint assembly is provided. The bushing assembly includes a first bushing member and a second bushing member. The first bushing member has a first inner surface that is configured to engage an outer surface of a shaft assembly and a first outer surface spaced apart from the first inner surface. Each of the first inner surface and the first outer surface extends between a first bushing member first end and a first bushing member second end. The second bushing member has a second inner surface that is configured to engage the first outer surface and a second outer surface that is configured to engage a sealing boot. Each of the second inner surface and the second outer surface extends between a second bushing member first end and a second bushing member second end. The first bushing member is rotatable relative to the second bushing member.

These and other advantages and features will become more apparent from the following description taken in conjunction with the drawings.

BRIEF DESCRIPTION OF THE DRAWINGS

The subject matter which is regarded as the invention is particularly pointed out and distinctly claimed in the claims

at the conclusion of the specification. The foregoing and other features, and advantages of the invention are apparent from the following detailed description taken in conjunction with the accompanying drawings in which:

FIG. 1 is a partial cross-sectional view of a variable stiffness joint assembly;

FIG. 2 is a partial cross sectional view of the variable stiffness joint assembly along section line 2-2;

FIG. 3 is a plan view of a bushing assembly provided with the variable stiffness joint assembly;

FIG. 4 is a cross-sectional view of the bushing assembly of FIG. 3;

FIG. 5 is a plan view of a bushing assembly;

FIG. 6 is a cross-sectional view of the bushing assembly of FIG. 5;

FIG. 7 is another cross-sectional view of the bushing assembly of FIG. 5;

FIG. 8 is a plan view of a bushing assembly;

FIG. 9 is a cross-sectional view of the bushing assembly of FIG. 8;

FIG. 10 is a plan view of a bushing assembly;

FIG. 11 is a cross-sectional view of the bushing assembly of FIG. 10;

FIG. 12 is a plan view of a bushing assembly; and

FIG. 13 is a cross-sectional view of the bushing assembly of FIG. 12.

DETAILED DESCRIPTION

Referring now to the Figures, where the invention will be described with reference to specific embodiments, without limiting same, it is to be understood that the disclosed embodiments are merely illustrative of the invention that may be embodied in various and alternative forms. The figures are not necessarily to scale; some features may be exaggerated or minimized to show details of particular components. Therefore, specific structural and functional details disclosed herein are not to be interpreted as limiting, but merely as a representative basis for teaching one skilled in the art to variously employ the present invention.

Referring to FIGS. 1 and 2, a variable stiffness joint assembly 10 is shown. The variable stiffness joint assembly 10 includes a shaft assembly 20, a bushing assembly 22, and a sealing boot 24.

The shaft assembly 20 is a torque transmitting shaft assembly that is used to transmit torque or power from a driving source, such as a transmission or transaxle, to a driven component, such as a vehicle wheel. The shaft assembly 20 includes a first member 30 and the second member 32.

The first member 30 extends along an axis 34. The first member 30 has a first outer surface 40 and a first inner surface 42 that is disposed opposite the first outer surface 40. The first outer surface 40 and the first inner surface 42 each extend between a first member first end 44 and the first member second end 46.

The first inner surface 42 defines an inner bore of the first member 30. The first inner surface 42 defines a plurality of first engagement elements 50. The plurality of first engagement elements 50 are disposed proximate the first member second end 46. The plurality of first engagement elements 50 are configured as a plurality of torque receiving grooves, torque receiving serrations, torque receiving protrusions, gear teeth, projections, or the like.

The second member 32 extends along the axis 34. The second member 32 is at least partially received within the inner bore of the first member 30. The second member 32

has a second outer surface **60** that extends between a second member first end **62** and a second member second end **64**.

The second outer surface **60** defines a plurality of second engagement elements **70**. The plurality of second engagement elements **70** are arranged to selectively engage the plurality of first engagement elements **50**. The plurality of second engagement elements **70** are configured as a plurality of torque transmitting grooves, torque transmitting serrations, torque transmitting protrusions, gear teeth, projections, or the like. Each element of the plurality of second engagement elements **70** is received within or disposed between corresponding engagement elements of the plurality of first engagement elements **50**. Engagement between elements of the plurality of first engagement elements **50** and an element of the plurality of second engagement elements **70** facilitates torque transmission between the first member **30** and the second member **32**.

The second member second end **64** is connected to a constant velocity joint assembly **80**. The constant velocity joint assembly **80** includes a constant velocity joint **82** and a joint assembly **84**. The constant velocity joint **82** includes an outer member **86** that extends towards the shaft assembly **20**. The outer member **86** is configured to receive at least a portion of the joint assembly **84**. The joint assembly **84** includes a plurality of rolling elements or torque transmitting elements that are disposed between the outer member **86** and the second member **32**. At least one of the first member **30** and the second member **32** is retained by the constant velocity joint **82** by the joint assembly **84**.

The bushing assembly **22** is configured as a compliant torsional bushing. The bushing assembly **22** is arranged to allow for relative rotational motion of the shaft assembly **20** while maintaining sealing integrity of the variable stiffness joint assembly **10**. The bushing assembly **22** is disposed about the first member **30** of the shaft assembly **20**. The bushing assembly **22** is disposed between the first outer surface **40** of the first member **30** and the sealing boot **24**.

Referring to FIGS. **3-11**, the bushing assembly **22** includes a bushing body **90**. The bushing body **90** is made of one or more compliant materials that allows for elastic deformation. The elastic deformation of the bushing body **90** enables the bushing body **90** to deflect in torsion. The bushing body **90** may be made of a composite material having non-linear stiffness characteristics. The bushing body **90** extends radially between an inner bushing surface **100** and an outer bushing surface **102**. The bushing body **90** extends axially between a first bushing face **104** and a second bushing face **106** along a bushing axis.

The inner bushing surface **100** is disposed about the first outer surface **40** of the first member **30**. The inner bushing surface **100** defines a first protrusion **110**. The first protrusion **110** may be provided as part of a plurality of ridges that extends between the first bushing face **104** and the second bushing face **106**. The plurality of ridges are arranged to retain a lubricant, such as grease, against the first outer surface **40**. The plurality of ridges are arranged to aid in retaining a lubricant within the variable stiffness joint assembly **10**.

The outer bushing surface **102** is configured to engage the sealing boot **24**. The outer bushing surface **102** defines a second protrusion **112**. The second protrusion **112** may be provided as part of another plurality of ridges that extend between the first bushing face **104** and the second bushing face **106**. Another plurality of ridges are arranged to aid in retaining the sealing boot **24** against the bushing assembly **22**.

The first bushing face **104** extends radially between a first end of the inner bushing surface **100** and a first end of the outer bushing surface **102**.

The second bushing face **106** is disposed opposite the first bushing face **104**. The second bushing face **106** extends radially between a second end of the inner bushing surface **100** and a second end of the outer bushing surface **102**.

The bushing assembly **22** also includes a boot stop **116**. The boot stop **116** extends away from the bushing body **90**. The boot stop **116** is disposed substantially perpendicular to the outer bushing surface **102**. The boot stop **116** is disposed proximate the first bushing face **104**. The boot stop **116** is arranged to axially seat the sealing boot **24** on the bushing assembly **22**.

Referring to FIGS. **5-7**, the bushing body **90** of the bushing assembly **22** may include a first cavity **120** and the second cavity **122**. The first cavity **120** may extend from the first bushing face **104** towards the second bushing face **106**. The first cavity **120** extends towards, but not through, the second bushing face **106** of the bushing body **90**. The second cavity **122** extends from the second bushing face **106** towards the first bushing face **104**. The second cavity **122** extends towards, but not through, the first bushing face **104** of the bushing body **90**.

As shown in FIGS. **5-7**, the first cavity **120** may be radially offset from the second cavity **122**. The first cavity **120** and the second cavity **122** alternate in a manner such that the first cavity **120** and the second cavity **122** are not axially aligned.

As shown in FIGS. **8** and **9**, the first cavity **120** may be axially and/or radially aligned with the second cavity **122** along an axis that is disposed substantially parallel to the axis **34** and/or disposed about the bushing axis of the bushing body **90**. As arranged, the first cavity **120** extends towards the second cavity **122**. The first cavity **120** and the second cavity **122** are separated from each other by a portion of the bushing body **90** that is disposed between opposing ends of each cavity.

Referring to FIGS. **10** and **11**, at least one of the first cavity **120** and the second cavity **122** may be provided with a fluid **130**. The fluid **130** may be an incompressible fluid that enables the bushing body **90** of the bushing assembly **22** to be more robust or resistant to compressive forces. In such an embodiment, the bushing assembly **22** may further include a sealing member **132**. The sealing member **132** may be disposed on the first bushing face **104** to seal the first cavity **120** and retain the fluid **130** within the first cavity **120**. The sealing member **132** may be adhered to the first bushing face **104** by an adhesive, a fastener, or the like. The sealing member **132** may alternatively or additionally be disposed on the second bushing face **106** to seal the second cavity **122** to retain the fluid **130** within the second cavity **122**. The sealing member **132** may be adhered to the second bushing face **106** by an adhesive, a fastener, or the like.

Referring to FIGS. **12** and **13**, an alternative bushing assembly **150** is shown. The alternative bushing assembly **150** is configured as a rotary, torsional bushing assembly. The alternative bushing assembly **150** includes a first bushing member **160** and a second bushing member **162**. The first bushing member **160** is configured to rotate relative to the second bushing member **162**.

The first bushing member **160** is configured as an inner race. The first bushing member **160** includes a first inner surface **170** and a first outer surface **172** that is disposed opposite the first inner surface **170**. The first inner surface

170 and the first outer surface 172 each extend between a first bushing member first end 174 and a first bushing member second end 176.

The first inner surface 170 is configured to engage the first outer surface 40 of the first member 30 of the shaft assembly 20. The first inner surface 170 defines a first protrusion 180. The first protrusion 180 extends towards the shaft assembly 20. The first protrusion 180 may be provided as part of a plurality of ridges that extend between the first bushing member first end 174 and the first bushing member second end 176. The plurality of ridges are arranged to retain a lubricant, such as grease, against the first outer surface 40. The plurality of ridges are arranged to aid in retaining a lubricant within the variable stiffness joint assembly 10.

The first outer surface 172 is spaced apart from the first inner surface 170. The first outer surface 172 defines a second protrusion 182. The second protrusion 182 extends towards the second bushing member 162. In at least one embodiment, the second protrusion 182 extends into the second bushing member 162.

The first outer surface 172 defines a first retention arm 190 and the second retention arm 192. The first retention arm 190 is disposed proximate the first bushing member first end 174 and is disposed substantially perpendicular to the first outer surface 172. The second retention arm 192 is disposed proximate the first bushing member second end 176 and is disposed substantially perpendicular to the first outer surface 172.

The second bushing member 162 is disposed about the first bushing member 160. The second bushing member 162 is disposed between the first retention arm 190 and the second retention arm 192. The second bushing member 162 includes a second inner surface 200 and a second outer surface 202 that is disposed opposite the second inner surface 200. The second inner surface 200 and the second outer surface 202 each extend between a second bushing member first end 204 and a second bushing member second end 206.

The second inner surface 200 is configured to engage the first outer surface 172 of the first bushing member 160. The second inner surface 200 defines a receiving groove 210 that is configured to receive the second protrusion 182.

The second outer surface 202 is configured to engage the sealing boot 24.

The second bushing member 162 defines a boot stop 214. The boot stop 214 extends away from the second outer surface 202 and is disposed substantially perpendicular to the second outer surface 202. The boot stop 214 is disposed proximate the second bushing member first end 204. The boot stop 214 is arranged to axially seat the sealing boot 24 on the alternative bushing assembly 150.

The sealing boot 24 extends between the bushing assembly 22 and the constant velocity joint assembly 80. The sealing boot 24 includes a convoluted portion 220 that extends between a first boot end 222 and a second boot end 224.

The first boot end 222 is operatively connected to the bushing assembly 22 by a first clamp 230 that is disposed about the first boot end 222. The first boot end 222 is at least partially disposed over or disposed on the outer bushing surface 102 of the bushing assembly 22. The second protrusion 112 of the outer bushing surface 102 engages the first boot end 222. The first boot end 222 is at least partially disposed over or disposed on the second outer surface 202 of the alternative bushing assembly 150. The first boot end 222 is configured to engage the boot stop 116 of the bushing

assembly 22. The first boot end 222 is configured to engage the boot stop 214 of the alternative bushing assembly 150.

The second boot end 224 is operatively connected to the constant velocity joint assembly 80 by a second clamp 232 that is disposed about the second boot end 224. The second boot end 224 is at least partially disposed over or disposed on the outer member 86 of the constant velocity joint 82 of the constant velocity joint assembly 80.

Throughout this specification, the term “attach,” “attachment,” “connected,” “coupled,” “coupling,” “mount,” or “mounting” shall be interpreted to mean that a structural component or element is in some manner connected to or contacts another element, either directly or indirectly through at least one intervening structural element, or is integrally formed with the other structural element.

While the invention has been described in detail in connection with only a limited number of embodiments, it should be readily understood that the invention is not limited to such disclosed embodiments. Rather, the invention can be modified to incorporate any number of variations, alterations, substitutions or equivalent arrangements not heretofore described, but which are commensurate with the spirit and scope of the invention. Additionally, while various embodiments of the invention have been described, it is to be understood that aspects of the invention may include only some of the described embodiments. Accordingly, the invention is not to be seen as limited by the foregoing description.

The invention claimed is:

1. A variable stiffness joint assembly, comprising:
 - a shaft assembly including a shaft;
 - a first member extending along an axis, the first member having a first outer surface and a first inner surface extending between a first member first end and a first member second end, the first inner surface configured to engage an outer surface of the shaft, the first outer surface defining a first retention arm located proximate the first member first end and defining a second retention arm located proximate the first member second end;
 - a second member extending along the axis and at least partially received within the first member, the second member having a second outer surface extending between a second member first end and a second member second end that is operatively connected to a constant velocity joint assembly;
 - a bushing assembly disposed about the first member, the bushing assembly comprising:
 - a bushing body extending radially between an inner bushing surface and an outer bushing surface and extending axially between a first bushing face and a second bushing face, the bushing body including a bushing member completely disposed between the first retention arm and the second retention arm, the inner bushing surface being disposed about the first outer surface of the first member; and
 - a sealing boot having a first boot end operatively connected to the bushing assembly, such that the bushing assembly is disposed between the first outer surface and the first boot end, and a second boot end operatively connected to the constant velocity joint assembly.
2. The variable stiffness joint assembly of claim 1, wherein the first inner surface defines a plurality of first engagement elements and the second outer surface defines a plurality of second engagement elements that are arranged to selectively engage the plurality of first engagement elements.

7

3. The variable stiffness joint assembly of claim 1, further comprising:

a clamp disposed about the first boot end and is arranged to secure the sealing boot to the bushing assembly.

4. A bushing assembly for a variable stiffness joint assembly, the bushing assembly comprising:

a bushing body disposed about a shaft assembly, the bushing body having an inner bushing surface, an outer bushing surface spaced apart from the inner bushing surface and including first and second retention arms, a first bushing face extending between a first end of the inner bushing surface and a first end of the outer bushing surface, and a second bushing face extending between a second end of the inner bushing surface and a second end of the outer bushing surface, the inner bushing surface defining a plurality of ridges that extend between the first bushing face and the second bushing face, the first and second retention arms being spaced apart from one another to receive a portion of another bushing body; and

a boot stop disposed proximate the first bushing face, the boot stop extending from the bushing body.

5. The bushing assembly of claim 4, wherein the bushing body is made of a composite material having a non-linear stiffness characteristic.

6. The bushing assembly of claim 4, wherein the boot stop extends from and is disposed perpendicular to the outer bushing surface.

7. The bushing assembly of claim 4, wherein the plurality of ridges extend towards the shaft assembly.

8. The bushing assembly of claim 7, wherein the outer bushing surface defines a second protrusion that engages a sealing boot that is at least partially disposed over the outer bushing surface.

8

9. The bushing assembly of claim 8, wherein the boot stop is configured to engage an end of the sealing boot.

10. A bushing assembly for a variable stiffness joint assembly, the bushing assembly comprising:

a first bushing member having a first inner surface that is configured to engage an outer surface of a shaft assembly and a first outer surface spaced apart from the first inner surface, each extending between a first bushing member first end and a first bushing member second end, the first outer surface defines a first retention arm disposed proximate the first bushing member first end and a second retention arm disposed proximate the first bushing member second end; and

a second bushing member completely disposed between the first retention arm and the second retention arm, the second bushing member having a second inner surface that is configured to engage the first outer surface and a second outer surface radially spaced apart from the first outer surface and is configured to engage a sealing boot, each axially extending between a second bushing member first end and a second bushing member second end, the first bushing member being rotatable relative to the second bushing member.

11. The bushing assembly of claim 10, wherein the first inner surface defines a first protrusion that is configured to engage the outer surface of the shaft assembly.

12. The bushing assembly of claim 10, wherein the first outer surface defines a second protrusion that extends towards the second bushing member.

13. The bushing assembly of claim 12, wherein the second inner surface defines a receiving groove that is configured to receive the second protrusion.

* * * * *