



US010385892B2

(12) **United States Patent**
Cugati et al.

(10) **Patent No.:** **US 10,385,892 B2**
(45) **Date of Patent:** **Aug. 20, 2019**

(54) **SYSTEM AND METHOD FOR PROVIDING HYDRAULIC POWER**

E02F 9/2296 (2013.01); *F15B 11/162* (2013.01); *F15B 11/165* (2013.01); *F15B 11/17* (2013.01); *E02F 3/308* (2013.01); *F15B 2211/41509* (2013.01)

(71) Applicant: **Caterpillar Global Mining LLC**, Oak Creek, WI (US)

(58) **Field of Classification Search**
CPC *F15B 11/162*; *F15B 11/165*; *F15B 11/17*; *E02F 9/2292*
See application file for complete search history.

(72) Inventors: **Sharath Cugati**, Dortmund (DE); **Christopher Williamson**, Ames, IA (US); **Pengfei Ma**, Naperville, IL (US); **Mark Vonderwell**, Franklin, WI (US); **Sean Johnson**, Ratingen (DE); **James W. Fuerst**, Wauwatosa, WI (US); **Jiao Zhang**, Naperville, IL (US)

(56) **References Cited**

U.S. PATENT DOCUMENTS

(73) Assignee: **Caterpillar Global Mining LLC**, Tucson, AZ (US)

4,030,623 A	6/1977	Bridwell et al.	
4,073,141 A	2/1978	Lohbauer	
4,531,366 A *	7/1985	Moriya	<i>E02F 9/2232</i> 60/421
5,048,293 A *	9/1991	Aoyagi	<i>E02F 9/2235</i> 60/420

(*) Notice: Subject to any disclaimer, the term of this patent is extended or adjusted under 35 U.S.C. 154(b) by 170 days.

(Continued)

FOREIGN PATENT DOCUMENTS

(21) Appl. No.: **15/384,423**

EP 2746466 6/2014

(22) Filed: **Dec. 20, 2016**

Primary Examiner — Michael Leslie

(65) **Prior Publication Data**

US 2018/0172037 A1 Jun. 21, 2018

(74) *Attorney, Agent, or Firm* — Oblon, McClelland, Maier & Neustadt

(51) **Int. Cl.**

<i>F16D 31/02</i>	(2006.01)
<i>F15B 21/08</i>	(2006.01)
<i>F15B 11/17</i>	(2006.01)
<i>F15B 11/16</i>	(2006.01)
<i>E02F 9/22</i>	(2006.01)
<i>E02F 3/42</i>	(2006.01)
<i>E02F 3/40</i>	(2006.01)
<i>E02F 3/30</i>	(2006.01)

(57) **ABSTRACT**

A hydraulic system for a machine includes a plurality of hydraulic component, wherein the hydraulic components include hydraulic actuators and hydraulic motors. The hydraulic system also includes a plurality of hydraulic circuits, and a plurality of hydraulic pumps for supplying hydraulic fluid to the plurality of hydraulic components via the hydraulic circuits. At least one hydraulic component receives hydraulic flow exclusively from a designated one of the hydraulic pumps and at least another, different hydraulic component receives shared hydraulic flow from a flow sharing set of the hydraulic pumps.

(52) **U.S. Cl.**

CPC *F15B 21/08* (2013.01); *E02F 3/404* (2013.01); *E02F 3/425* (2013.01); *E02F 9/2242* (2013.01); *E02F 9/2292* (2013.01);

18 Claims, 3 Drawing Sheets

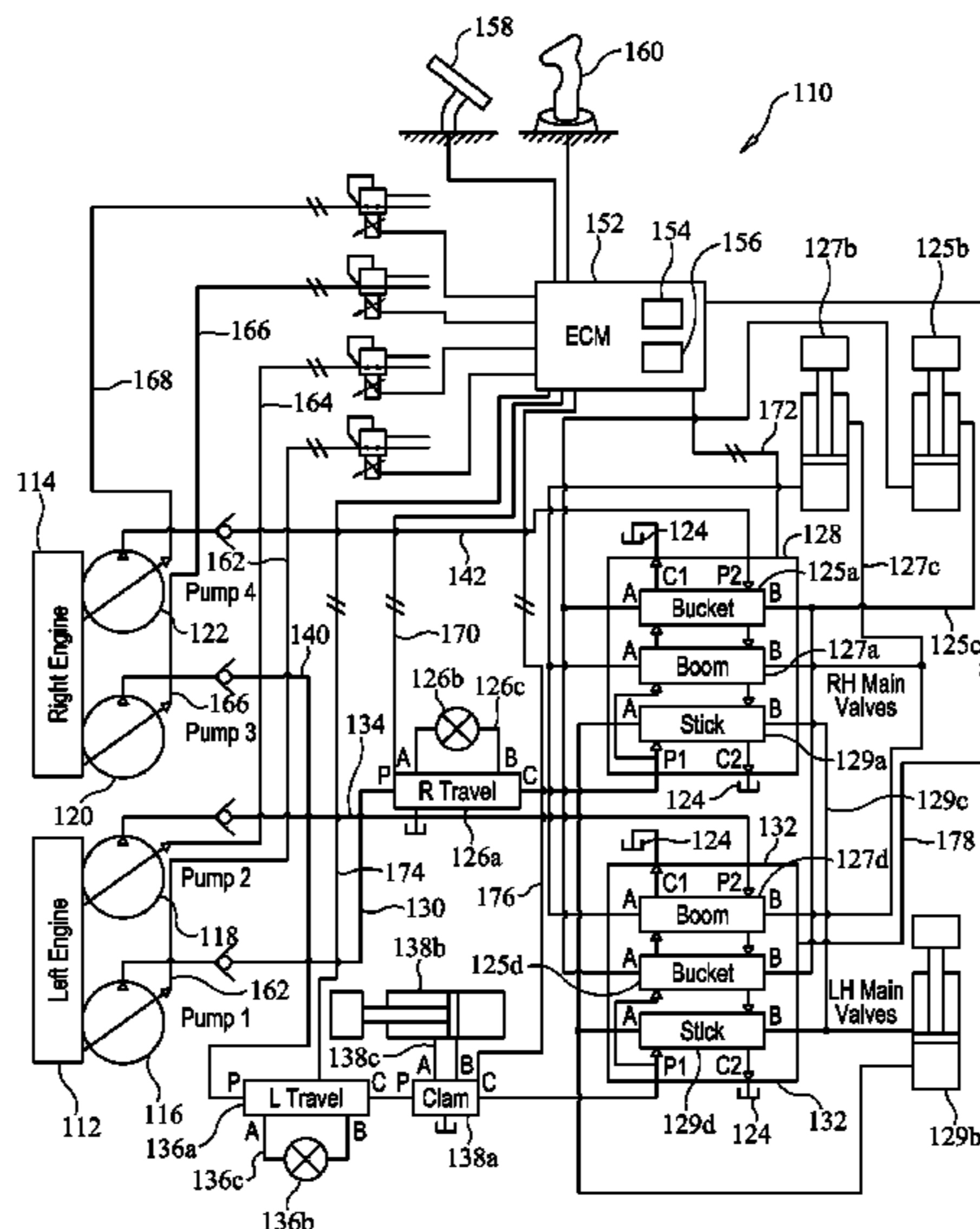

(56)

References Cited

U.S. PATENT DOCUMENTS

6,851,207	B2	2/2005	Yoshimatsu	
8,191,290	B2	6/2012	Hughes, IV et al.	
8,607,557	B2 *	12/2013	Ikeda	E02F 9/123 60/422
8,943,819	B2 *	2/2015	Knussman	F15B 7/006 60/422
9,206,821	B2	12/2015	Post et al.	
2011/0056194	A1	3/2011	Wojcicki et al.	

* cited by examiner

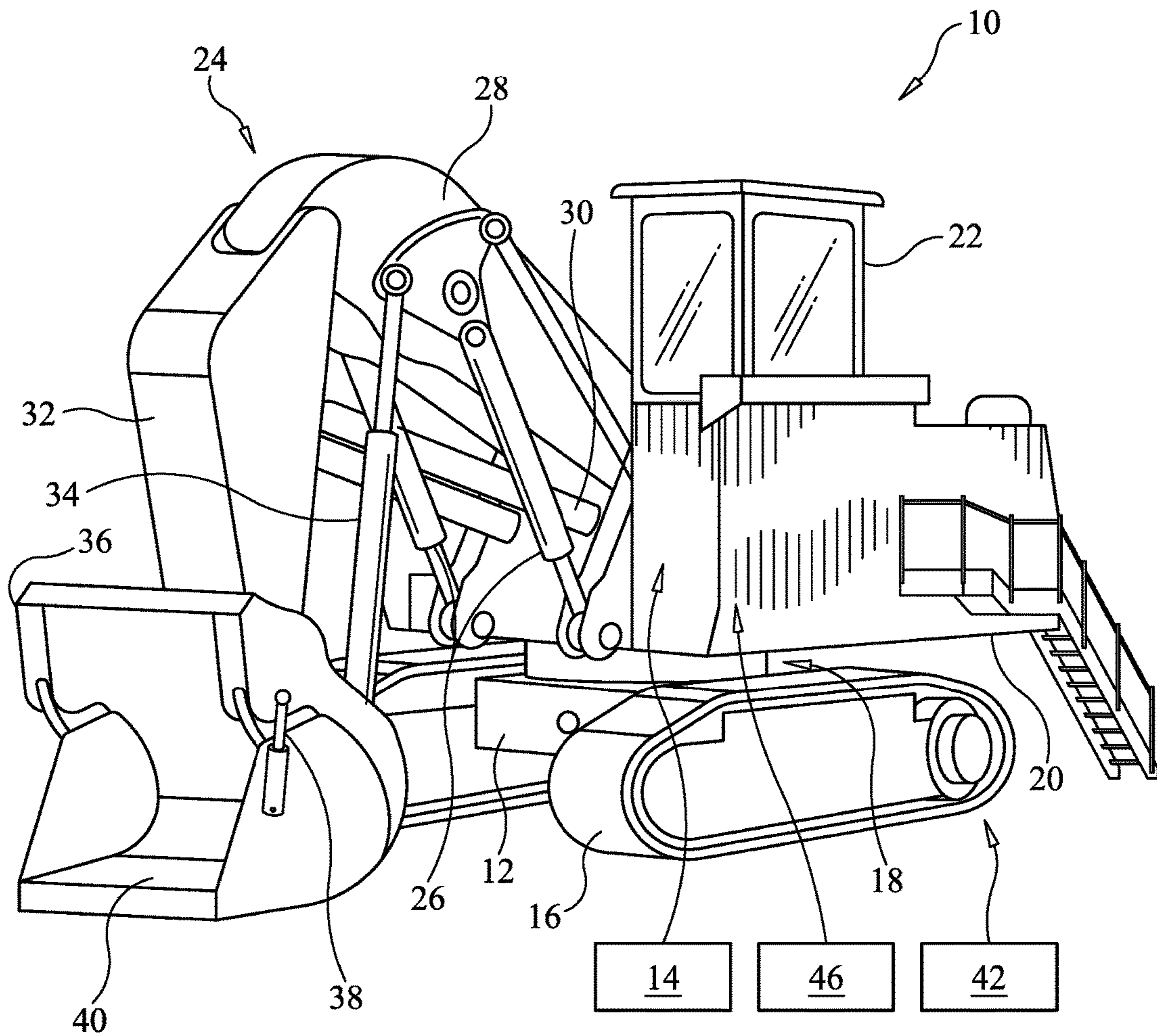

FIG. 1

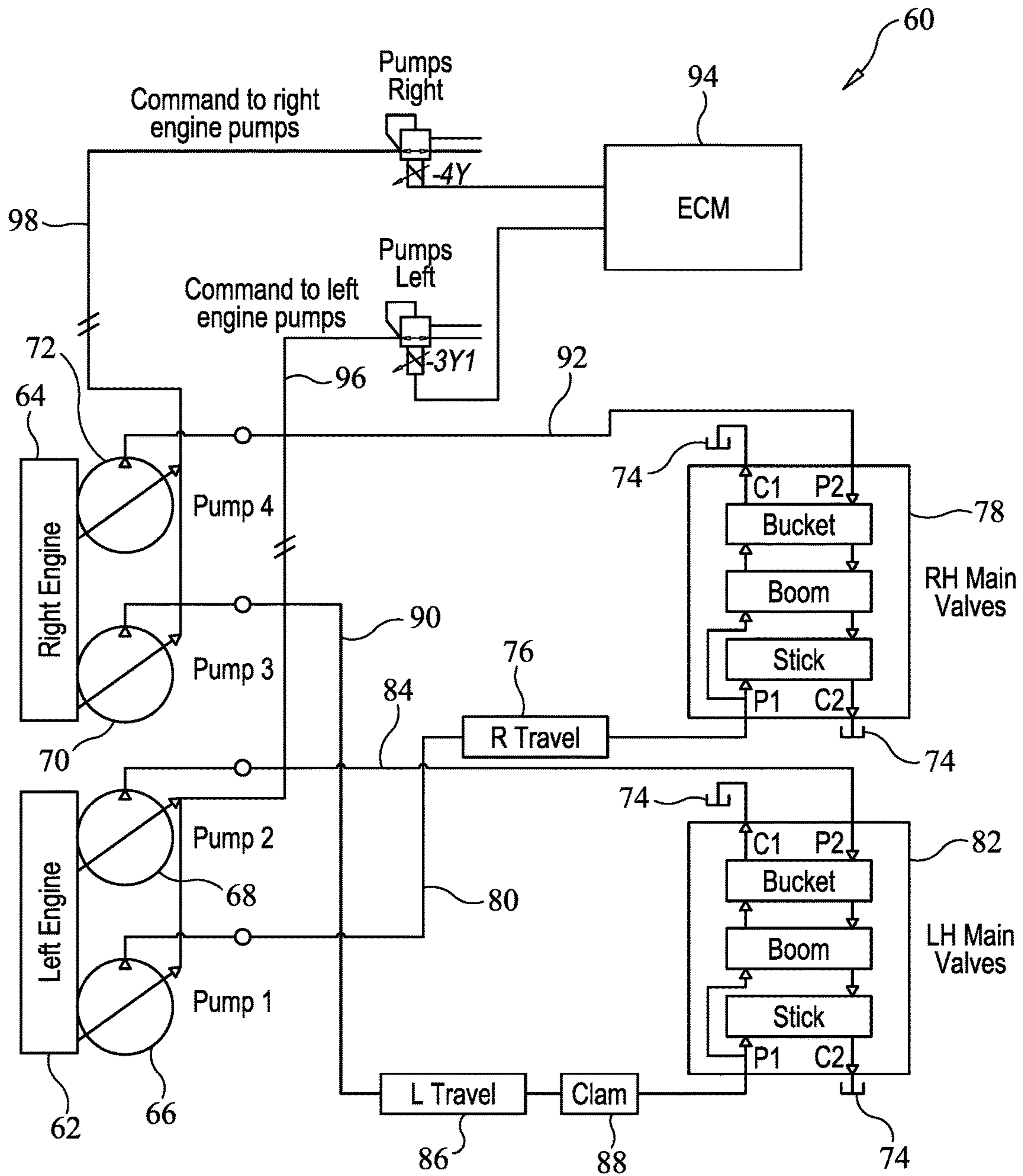

FIG. 2
Prior Art

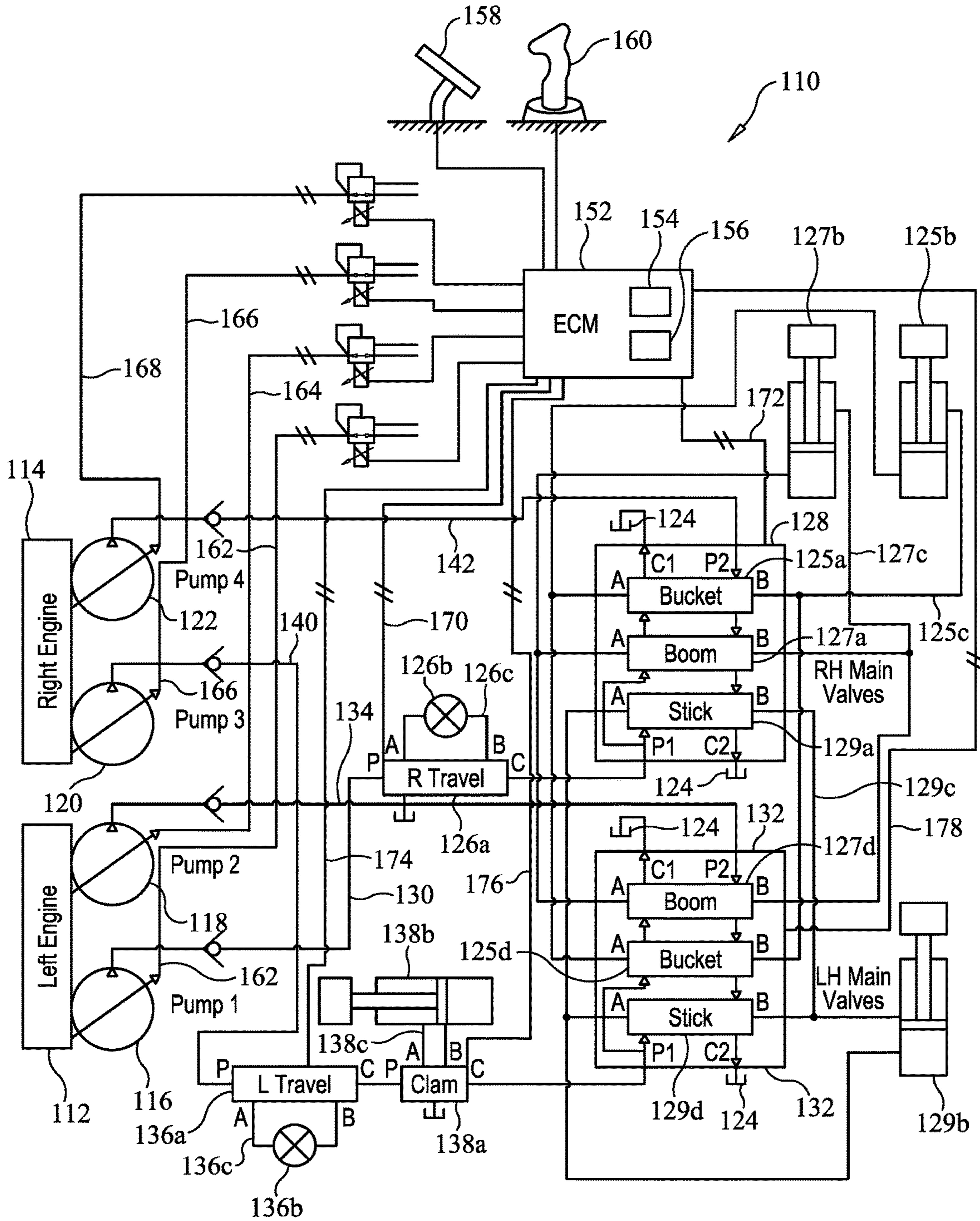

FIG. 3

1**SYSTEM AND METHOD FOR PROVIDING
HYDRAULIC POWER**

TECHNICAL FIELD

The present disclosure relates generally to a strategy for providing hydraulic power through a plurality of hydraulic circuits of a machine.

BACKGROUND

Fuel is a major portion of the total cost of ownership for a number of hydraulic machines, such as, for example, hydraulic mining excavators or shovels. As such, hydraulic systems with greater efficiency may offer a competitive advantage. Typically, however, these systems are not optimized for energy efficiency. For example, on some hydraulic mining shovels, there are four main pumps. One pump powers clam cylinders, while travel motors are powered by one pump for each side of the machine. Yet, regardless of the work cycle segment being performed, when an operator actuates the pedal for propulsion, all four pumps get the same command and, typically, this results in pressurized oil being provided at a much higher rate than is necessary.

European Patent Application No. EP 2746466 to Cugati et al. discloses a system and method for providing hydraulic power to a plurality of hydraulic circuits of a machine. In particular, the disclosed system allows assigning individual hydraulic pumps to different hydraulic circuits of the hydraulic system. As such, the system nearly eliminates all flow sharing between the different hydraulic circuits to avoid pressure drop losses.

As should be appreciated, there is a continuing need to provide greater energy efficiency in the area of hydraulic machinery. The present disclosure is directed to such an endeavor.

SUMMARY OF THE INVENTION

In one aspect, a hydraulic system for a machine includes a plurality of hydraulic component, wherein the hydraulic components include hydraulic actuators and hydraulic motors. The hydraulic system also includes a plurality of hydraulic circuits, and a plurality of hydraulic pumps for supplying hydraulic fluid to the plurality of hydraulic components via the hydraulic circuits. At least one hydraulic component receives hydraulic flow exclusively from a designated one of the hydraulic pumps and at least another, different hydraulic component receives shared hydraulic flow from a flow sharing set of the hydraulic pumps.

In another aspect, a hydraulic excavator includes a machine frame supporting a hydraulic system. The hydraulic system includes a plurality of hydraulic components, wherein the hydraulic components include hydraulic actuators and hydraulic motors. The hydraulic system also includes a plurality of hydraulic circuits and a plurality of hydraulic pumps for supplying hydraulic fluid to the plurality of hydraulic components via the hydraulic circuits. An electronic controller provides independent pump control commands to each of the hydraulic pumps such that at least one hydraulic component receives hydraulic flow exclusively from a designated one of the hydraulic pumps and at least another, different hydraulic component receives shared hydraulic flow from a flow sharing set of the hydraulic pumps.

In yet another aspect, a method of controlling hydraulic flow for a hydraulic system of a machine includes a step of

2

circulating hydraulic fluid from a plurality of hydraulic pumps to a plurality of hydraulic components, wherein the hydraulic components include hydraulic actuators and hydraulic motors, via a plurality of hydraulic circuits. The method also includes steps of providing hydraulic flow to at least one hydraulic component exclusively from a designated one of the hydraulic pumps, and providing shared hydraulic flow to at least another, different hydraulic component from a flow sharing set of the hydraulic pumps.

BRIEF DESCRIPTION OF THE DRAWINGS

FIG. 1 is a schematic diagram of a hydraulic excavator, according to the present disclosure;

FIG. 2 is a prior art system of providing hydraulic power to a plurality of hydraulic circuits; and

FIG. 3 is a system of providing hydraulic power to a plurality of hydraulic circuits of the hydraulic excavator of FIG. 1, according to the present disclosure.

DETAILED DESCRIPTION

An exemplary machine, according to the present disclosure, is shown generally at **10** and, as shown, may be a hydraulic excavator, such as, for example, a hydraulic mining excavator or hydraulic mining shovel. Although a hydraulic excavator is shown and described, the present disclosure is broadly applicable to a variety of dozers, loaders, motor graders, and other types of mobile or stationary machinery that utilize hydraulic systems, including hydraulic components, such as hydraulic actuators and hydraulic motors, to accomplish a variety of tasks and machine movements.

The exemplary hydraulic excavator **10** may generally include a machine frame **12** supporting at least one engine **14**, such as an internal combustion engine, or other power source. As should be appreciated, the engine **14** may produce mechanical power that may be used by one or more machine systems or components, also supported on machine frame **12**. For example, the engine **14** may power, among various other machine systems, a propulsion or drive system, which may include a tracked undercarriage **16** or other propulsion or traction device, for propelling the machine **10**. Supported above the undercarriage **16** may be a turntable **18**, as is known to those skilled in the art, which may be used to rotatably support a platform **20** including an operator control station **22**, which may house various operator input devices and controls.

The machine frame **12** may also support a hydraulic system **24**. According to the present disclosure, the engine **14** may produce mechanical power that may be converted to hydraulic power using the hydraulic system **24**. The hydraulic system **24** may include a variety of known hydraulic components, such as, for example, tanks, valves, accumulators, actuators, motors, and other suitable components for producing and/or distributing a pressurized flow of hydraulic fluid. Hydraulic system **24** may further comprise fluid sources, for example, a reservoir or sump, and one or more hydraulic pumps, which may include variable displacement pumps, fixed displacement pumps, variable delivery pumps or other suitable pressurizing pumps or systems. The hydraulic pumps may be operationally connected to the engine **14**, or may be indirectly connected to the engine **14** via a gear mechanism or the like.

The hydraulic system **24** may include a plurality of hydraulic actuators, such as, for example, a pair of hydraulic actuators **26** for operating a boom **28** of the machine **10**, a

pair of hydraulic actuators **30** for operating a stick **32** of the machine **10**, a pair of hydraulic actuators **34** for operating a bucket **36** of the machine **10**, and hydraulic actuators **38** for those machines configured with a clam bucket **40**. As should be appreciated by those skilled in the art, the various actuators **26**, **30**, **34**, and **38** may be embodied as hydraulic cylinders, including a piston and piston rod reciprocating within the piston.

The hydraulic system **24** may also include a pair of hydraulic motors **42** associated with left and right propulsion drives for the tracked undercarriage **16**. It should be appreciated that, in other embodiments, different numbers and/or types of hydraulic actuators and/or hydraulic motors may be used in hydraulic system **24**. Those skilled in the art should also appreciate that various alternative or additional tools or implements may be supported by the machine **10** and operated using hydraulic system **24**.

Machine **10** may also utilize or include a control system or device, such as an electronic controller **46**, suitable for controlling the hydraulic system **24** and other components, including, for example, the engine **14**, of machine **10**. The electronic controller **46** may be operatively connected to operator input devices, which may be located in the operator control station **22**, and may be adapted to receive an electronic signal input from an operator input device of a desired movement, or desired velocity, of the machine **10**. The electronic controller **46**, in turn, may determine a power demand associated with one or more of the hydraulic actuators **26**, **30**, **34**, and **38** and/or motors **42** of the hydraulic system **24** for performing the desired movement.

The electronic controller **46** may be of standard design and may include a processor, such as, for example, a central processing unit, a memory, and an input/output circuit that facilitates communication internal and external to the electronic controller **46**. The processors, for example, may control operation of the electronic controller **46** by executing operating instructions, such as, for example, computer readable program code stored in a memory, wherein operations may be initiated internally or externally to the electronic controller **46**.

Control schemes may be utilized that monitor outputs of systems or devices, such as, for example, sensors, actuators, or control units, via the input/output circuit to control inputs to various other systems or devices. Memory, as used herein, may comprise temporary storage areas, such as, for example, cache, virtual memory, or random access memory, or permanent storage areas, such as, for example, read-only memory, removable drives, network/internet storage, hard drives, flash memory, memory sticks, or any other known volatile or non-volatile data storage devices. One skilled in the art will appreciate that any computer based system or device utilizing similar components for controlling the machine systems or components described herein, is suitable for use with the present disclosure.

Referring now to FIG. **2**, a prior art hydraulic system for use with the hydraulic excavator **10** is shown generally at **60**. According to the prior art example, the hydraulic system **60** may include two engines **62**, **64**, with each of the engines **62**, **64** providing mechanical power to two of pumps **66**, **68**, **70**, **72**. Each of the pumps **66**, **68**, **70**, **72** may draw hydraulic fluid from a reservoir, tank or sump **74**. Pump one **66** may be configured to supply hydraulic fluid to a right-hand travel motor valve **76**, which provides hydraulic fluid to a right-hand travel motor, and a right-hand control valve block **78**, which provides hydraulic fluid to at least one of a bucket valve, boom valve, and stick valve having circuits fluidly connected to corresponding actuators, along at least a first

circuit **80**. Pump two **68** may supply hydraulic fluid to a left-hand control valve block **82**, which provides hydraulic fluid to at least one of a bucket valve, boom valve, and stick valve having circuits fluidly connected to corresponding actuators, along at least a second circuit **84**.

Pump three **70** may supply hydraulic fluid to a left-hand travel motor valve **86**, which provides hydraulic fluid to a left-hand travel motor, one or more bucket clam cylinder valves **88**, which provide hydraulic fluid to corresponding actuators, and the left-hand control valve block **82** along at least a third circuit **90**. The fourth pump **72** may supply hydraulic fluid to the right-hand control valve block **78** along at least a fourth circuit **92**. According to this prior art embodiment, the left engine **62** powers pump one **66** and pump two **68**, while the right engine **64** powers pump three **70** and pump four **72**.

An electronic controller **94** provides electronic signals **96**, **98** to pumps **66**, **68**, **70**, **72** and valves **76**, **78**, **82**, **86**, **88**, such as electronic control valves, to set a pump flow rate and valve displacement proportional to an operator input command. According to the prior art example, all four pumps **66**, **68**, **70**, **72** receive the same flow command when both engines **62**, **64** are running. So, for example, if the operator steps on a clam pedal, all four pumps **66**, **68**, **70**, **72** may increase flow rate, even though only pump three **70** is actually connected to one or more clam cylinders via one or more valves **88**. Similarly, all four pumps **66**, **68**, **70**, **72** may increase flow rate when only the travel motors, receiving hydraulic fluid from valves **76** and **86** require hydraulic flow.

Turning now to FIG. **3**, a hydraulic system according to the present disclosure is shown at **110**. The exemplary hydraulic system **110** includes two engines **112**, **114**, such as, for example, internal combustion engines, with each engine **112**, **114** providing mechanical power to two of pumps **116**, **118**, **120**, **122**. Each of the pumps **116**, **118**, **120**, **122** may be variable displacement pumps, and may draw hydraulic fluid from a reservoir, tank or sump **124** and supply circuits **125c**, **126c**, **127c**, **129c**, **130**, **134**, **136c**, **138c**, **140**, **142** with hydraulic fluid.

Pump one **116** may be configured to supply hydraulic fluid to a right-hand travel motor valve **126a**, fluidly connected to right-hand travel motor **126b** via circuit **126c**, and a right-hand control valve block **128** along at least a first circuit **130**. Right-hand control valve block **128** may include: a right-hand bucket valve **125a**, fluidly connected to a bucket cylinder **125b**, or one side or port of bucket cylinder **125b** via circuit **125c**; a right-hand boom valve **127a**, fluidly connected to a boom cylinder **127b** via circuit **127c**; and a right-hand stick valve **129a**, fluidly connected to a stick cylinder **129b** via circuit **129c**.

Pump two **118** may supply hydraulic fluid to a left-hand control valve block **132** along at least a second circuit **134**. Left-hand control valve block **128** may include: a left-hand bucket valve **125d**, or side or port thereof, fluidly connected to the bucket cylinder **125b** via circuit **125c**; a left-hand boom valve **127d**, fluidly connected to the boom cylinder **127b** via circuit **127c**; and a left-hand stick valve **129d**, fluidly connected to the stick cylinder **129b** via circuit **129c**.

Pump three **120** may supply pressurized hydraulic fluid to a left-hand travel motor valve **136a**, fluidly connected to left-hand travel motor **136b** via circuit **136c**, a bucket clam cylinder valve **138a**, fluidly connected to a bucket claim cylinder **138b** via circuit **138c**, and the left-hand control valve block **132** along a third circuit **140**. The fourth pump **122** may supply hydraulic fluid to the right-hand control valve block **128** along a fourth circuit **142**.

According to this embodiment, the left engine **112** powers pump one **116** and pump two **118**, while the second engine **114** powers pump three **120** and pump four **122**. It should be appreciated that a different number of pumps **116, 118, 120, 122** and a different number of circuits **125c, 126c, 127c, 129c, 130, 134, 136c, 138c, 140, 142** may be utilized in accordance to the strategy provided herein.

Control valves, such as electronic control valves, **126a, 125a, 125d, 127a, 127d, 129a, 129d, 136a, 138a** may regulate hydraulic flow between the pumps **116, 118, 120, 122** and the various circuits **125c, 126c, 127c, 129c, 130, 134, 136c, 138c, 140, 142** in a known manner. For example, some or all of control valves **126a, 125a, 125d, 127a, 127d, 129a, 129d, 136a, 138a** may be open center valves and may be configured to supply hydraulic fluid to a first circuit, for example, receive return hydraulic fluid from the first circuit, supply hydraulic fluid to a different circuit, bypassing the first circuit, and/or dividing, or sharing, hydraulic fluid between the first circuit and the different circuit. An exemplary hydraulic system for use with the present strategy is taught in commonly owned European Patent Application No. EP 2746466 to Cugati et al., which is hereby incorporated by reference.

An electronic controller **152**, which may include a processor **154** and a memory **156**, and may be similar to the electronic controller **46** described above with reference to FIG. 1, may be in communication with pumps **116, 118, 120, 122** and electronic control valves **126a, 125a, 125d, 127a, 127d, 129a, 129d, 136a, 138a** to control hydraulic flow to the various actuators **125b, 127b, 129b, 138b** and motors **126b, 136b**. Hydraulic flow may be controlled, at least in part, by receipt of signals received from operator control devices, such as, for example, a pedal **158** and a joystick **160**, which may be located in the operator control station **22**, shown in FIG. 1, and also pressure sensors located at various locations in the circuit (e.g., at pumps, cylinder head-end and rod-end).

The electronic controller **152** may include a hydraulic flow control module or algorithm, such as a set of operating instructions stored in memory **156**, for controlling hydraulic flow of the hydraulic system **110**. The electronic controller **152**, based on the hydraulic flow control module, may be configured to generate and/or transmit electronic control signals **162, 164, 166, 168** to respective pumps **116, 118, 120, 122**, and electronic control signals **170, 172, 174, 176, 178** to respective electronic control valves **126a, 125a, 125d, 127a, 127d, 129a, 129d, 136a, 138a** to control the same. It should be appreciated that the electronic controller **152** may send separate signals, or similar signals, to each of the valves in control valve blocks **128, 132**. Control signals **172** and **178** will each be a combination of individual boom, stick and bucket control valve signals.

According to the present disclosure, each pump **116, 118, 120, 122** may get an independent command, or command signal, **162, 164, 166, 168**, and/or each electronic control valve **126a, 125a, 125d, 127a, 127d, 129a, 129d, 136a, 138a** may get a separate command, or command signal, **170, 172, 174, 176, 178**. During operation, at least one hydraulic component **125b, 127b, 129b, 138b, 126b, 136b** may receive hydraulic flow exclusively from a designated one of the hydraulic pumps **116, 118, 120, 122** and at least another, different hydraulic component **125b, 127b, 129b, 138b, 126b, 136b** may receive shared hydraulic flow from a flow sharing set of the hydraulic pumps **116, 118, 120, 122**, the set of which may exclude the pump providing exclusive flow. Further, the electronic controller **152** may determine or receive information regarding a work cycle segment or task

of the machine **10**, which may be based on signals received from operator control devices, such as, for example, **158, 160**. The current work cycle segment or task may be used by the electronic controller **152** to determine how to control the hydraulic flow.

For example, when an operator requests propulsion, such as by actuating the pedal **158** or joystick **160**, pump one **116** and pump three **120** may be exclusively activated, or stroked, to provide the requested flow. That is, during a travel work cycle segment of the machine **10**, the relevant pumps (e.g., pump one **116** and pump three **120**) are independently activated, as opposed to controlling multiple pumps together or in pairs, regardless of the task being performed.

Likewise, when affecting movement of the clam cylinder **138**, such as by actuating the pedal **158**, joystick **160**, or other operator control device, pump three **120** may be independently activated, or stroked, to provide the desired flow. This may occur during a dumping work cycle segment of the machine **10**. Thus, exclusive and desired hydraulic flow may be provided from the relevant pump, pump three **120**, exclusively to the clam actuator **138**. The remaining pumps **116, 118, 122** and control valves **126a, 125a, 125d, 127a, 127d, 129a, 129d, 136a, 138a** may continue to work with pump flow shared between functions. According to the exemplary embodiment, exclusive flow and shared flow, supplying hydraulic fluid to different circuits **125c, 126c, 127c, 129c, 130, 134, 136c, 138c, 140, 142**, may occur simultaneously.

INDUSTRIAL APPLICABILITY

The present disclosure relates generally to providing hydraulic power to a plurality of hydraulic circuits of a machine. One exemplary machine suited to this disclosure is a hydraulic excavator. However, the systems and methods described herein can be adapted to a large variety of machines and tasks.

Referring generally to FIGS. 1-3 and, more specifically, to FIG. 1, an exemplary hydraulic excavator **10** may generally include a machine frame **12** supporting at least one engine **14**. The engine **14** may produce mechanical power that may be used by one or more machine systems or components, also supported on the machine frame **12**. For example, the engine **14** may power a hydraulic system **24**, which produces pressurized hydraulic fluid to power a propulsion system, which may include a tracked undercarriage **16**, and/or an implement or tool of the machine **10**, including boom **28**, stick **32**, bucket **36** and/or bucket clam **40**. In particular, and according to the exemplary embodiment, the hydraulic system **24** may power hydraulic actuators **125b, 127b, 129b, 138b** and motors **126b, 136b** of the exemplary implement and hydraulic motors **126b, 136b** powering the tracked undercarriage **16**.

With specific reference to FIG. 3, a hydraulic system **110** of the present disclosure is configured such that independent electronic control signals **162, 164, 166, 168** to respective pumps **116, 118, 120, 122** and/or independent electronic control signals **170, 172, 174, 176, 178** to respective electronic control valves **126a, 125a, 125d, 127a, 127d, 129a, 129d, 136a, 138a** for controlling positions of the same are utilized so that only relevant ones of pumps **116, 118, 120, 122** are stroked during certain tasks or work cycle segments. For example, the pumps **116, 118, 120, 122** may supply only the hydraulic flow that is needed for specific tasks.

In particular, for example, when an operator requests propulsion, such as by actuating the pedal **158** or joystick

160, pump one 116 and pump three 120 may be exclusively activated, or stroked. That is, during a travel work cycle segment of the machine 10, the relevant pumps 116, 120 may be independently activated, as opposed to sending the same electronic control signal to all of the pumps 116, 118, 120, 122. Likewise, when affecting movement of the clam cylinder 138b, such as by actuating the pedal 158, joystick 160, or other operator control device, pump three 140 may be independently activated to provide the needed hydraulic flow, rather than stroking all four pumps 116, 118, 120, 122, which would result in more fuel consumption than necessary. Shared flow with regard to some hydraulic circuits 125c, 126c, 127c, 129c, 130, 134, 136c, 138c, 140, 142 and exclusive flow with regard to one or more different circuits may occur simultaneously.

The present disclosure is directed to the combination of exclusive hydraulic flow and shared hydraulic flow in a machine having a hydraulic system utilizing multiple hydraulic pumps and hydraulic circuits. The strategy results in significant cost savings, including fuel cost savings.

It should be understood that the above description is intended for illustrative purposes only, and is not intended to limit the scope of the present disclosure in any way. Thus, those skilled in the art will appreciate that other aspects of the disclosure can be obtained from a study of the drawings, the disclosure and the appended claims.

What is claimed is:

1. A hydraulic system for a machine, including:
 - a plurality of engines;
 - a plurality of hydraulic components, including at least three hydraulic components, wherein the hydraulic components include hydraulic actuators and hydraulic motors;
 - a plurality of hydraulic circuits, including at least three hydraulic circuits; and
 - a plurality of hydraulic pumps configured to supply hydraulic fluid to the plurality of hydraulic components via the hydraulic circuits, the plurality of hydraulic pumps including at least three hydraulic pumps, and each of the plurality of hydraulic pumps being configured to receive independent pump control commands to provide hydraulic flow exclusively to a corresponding hydraulic component of the plurality of hydraulic components in response to a command to activate the corresponding hydraulic component,
 - wherein at least one hydraulic component of the plurality of hydraulic components receives the hydraulic flow exclusively from a designated one of the hydraulic pumps, and at least another hydraulic component of the plurality of hydraulic components, different from said at least one hydraulic component, receives shared hydraulic flow from a flow sharing set of the hydraulic pumps, excluding the designated one of the hydraulic pumps, and
 - wherein at least one of the engines has associated therewith two of the plurality of hydraulic pumps.
2. The hydraulic system of claim 1, further including a plurality of electronic control valves configured to regulate the hydraulic flow between the hydraulic pumps and the plurality of hydraulic components.
3. The hydraulic system of claim 1, further including a travel motor configured to receive the hydraulic flow exclusively from the designated one of the hydraulic pumps.
4. The hydraulic system of claim 3, wherein the travel motor receives the hydraulic flow exclusively from the designated one of the hydraulic pumps during a travel work cycle segment of the machine.

5. The hydraulic system of claim 1, further comprising a hydraulic actuator configured to receive the hydraulic flow exclusively from the designated one of the hydraulic pumps.

6. The hydraulic system of claim 5, further comprising a clam actuator configured to receive the hydraulic flow exclusively from the designated one of the hydraulic pumps.

7. The hydraulic system of claim 6, wherein the clam actuator receives the hydraulic flow exclusively from the designated one of the hydraulic pumps during a dumping work cycle segment of the machine.

8. The hydraulic system of claim 1, further comprising a boom actuator, a stick actuator, and a bucket actuator configured to receive the shared hydraulic flow from the flow sharing set of hydraulic pumps.

9. The hydraulic system of claim 8, wherein the boom actuator, the stick actuator, and the bucket actuator receive the shared hydraulic flow from the flow sharing set of hydraulic pumps during a dumping work cycle segment.

10. The hydraulic system of claim 1, further including an electronic controller configured to provide the independent pump control commands to each of the plurality of hydraulic pumps.

11. A hydraulic excavator, including:

a machine frame supporting a hydraulic system;

the hydraulic system including:

a plurality of hydraulic components, wherein the hydraulic components include hydraulic actuators and hydraulic motors;

a plurality of hydraulic circuits;

a plurality of hydraulic pumps configured to supply hydraulic fluid to the plurality of hydraulic components via the hydraulic circuits, each of the plurality of hydraulic pumps being configured to receive independent pump control commands to provide hydraulic flow exclusively to a corresponding hydraulic component of the plurality of hydraulic components in response to a command to activate the corresponding hydraulic component; and

an electronic controller configured to provide the independent pump control commands to each of the hydraulic pumps such that at least one hydraulic component of the plurality of hydraulic components receives the hydraulic flow exclusively from a designated one of the hydraulic pumps, and at least another hydraulic component of the plurality of the hydraulic components, different from said at least one hydraulic component, receives shared hydraulic flow from a flow sharing set of the hydraulic pumps; wherein the hydraulic excavator further comprises a boom actuator, a stick actuator, and a bucket actuator configured to receive the shared hydraulic flow from the flow sharing set of hydraulic pumps.

12. The hydraulic excavator of claim 11, further comprising a travel motor configured to receive the hydraulic flow exclusively from the designated one of the hydraulic pumps.

13. The hydraulic excavator of claim 11, further comprising a hydraulic actuator configured to receive the hydraulic flow exclusively from the designated one of the hydraulic pumps.

14. A method of controlling hydraulic flow for a hydraulic system of a machine, the method including:

circulating hydraulic fluid from a plurality of hydraulic pumps to a plurality of hydraulic components, wherein at least a first hydraulic pump of the plurality of hydraulic pumps is associated with a first engine, at least a second hydraulic pump of the plurality of hydraulic pumps is associated with a second engine

different from the first engine, the hydraulic components include hydraulic actuators and hydraulic motors, via a plurality of hydraulic circuits, each of the plurality of hydraulic pumps being configured to receive independent pump control commands to provide the hydraulic flow exclusively to a corresponding hydraulic component of the plurality of hydraulic components in response to a command to activate the corresponding hydraulic component;

providing the hydraulic flow to at least one hydraulic component of the plurality of hydraulic components exclusively from a designated one of the hydraulic pumps; and

providing shared hydraulic flow to at least another hydraulic component of the plurality of hydraulic components, different from said at least one hydraulic component from a flow sharing set of the hydraulic pumps, excluding the designated one of the hydraulic pumps.

15. The method of claim **14**, further including providing the hydraulic flow to a travel motor exclusively from the designated one of the hydraulic pumps.

16. The method of claim **14**, further including providing the hydraulic flow to a hydraulic actuator exclusively from the designated one of the hydraulic pumps.

17. The method of claim **16**, further including providing the hydraulic flow exclusively to a clam actuator from the designated one of the hydraulic pumps.

18. The method of claim **14**, further including providing the shared hydraulic flow to a boom actuator, a stick actuator, and a bucket actuator from the flow sharing set of the hydraulic pumps.

* * * * *