



US010385740B2

(12) **United States Patent**
Aras et al.

(10) **Patent No.:** **US 10,385,740 B2**
(45) **Date of Patent:** **Aug. 20, 2019**

(54) **CAMSHAFT ADJUSTER**

(71) Applicant: **SCHAEFFLER TECHNOLOGIES**
AG & CO. KG, Herzogenaurach (DE)

(72) Inventors: **Resat Aras**, Fuerth (DE); **Juergen**
Weber, Erlangen (DE)

(73) Assignee: **SCHAEFFLER TECHNOLOGIES**
AG & CO. KG, Herzogenaurach (DE)

(*) Notice: Subject to any disclaimer, the term of this
patent is extended or adjusted under 35
U.S.C. 154(b) by 0 days.

(21) Appl. No.: **15/758,877**

(22) PCT Filed: **Sep. 2, 2016**

(86) PCT No.: **PCT/DE2016/200414**

§ 371 (c)(1),
(2) Date: **Mar. 9, 2018**

(87) PCT Pub. No.: **WO2017/041799**

PCT Pub. Date: **Mar. 16, 2017**

(65) **Prior Publication Data**

US 2018/0298790 A1 Oct. 18, 2018

(30) **Foreign Application Priority Data**

Sep. 10, 2015 (DE) 10 2015 217 292

(51) **Int. Cl.**
F01L 1/34 (2006.01)
F01L 1/352 (2006.01)
F01L 1/344 (2006.01)
F01L 1/02 (2006.01)

(52) **U.S. Cl.**
CPC **F01L 1/352** (2013.01); **F01L 1/022**
(2013.01); **F01L 1/344** (2013.01); **F01L**
2103/00 (2013.01)

(58) **Field of Classification Search**

CPC . F01L 1/352; F01L 1/022; F01L 1/344; F01L
2103/00

See application file for complete search history.

(56) **References Cited**

U.S. PATENT DOCUMENTS

5,172,661 A 12/1992 Brune et al.
5,327,859 A 7/1994 Pierik et al.
6,668,774 B1 12/2003 Dauer et al.
6,981,478 B2 1/2006 Schäfer et al.
7,673,598 B2 3/2010 Schaefer et al.
2003/0037741 A1* 2/2003 Kohrs F01L 1/022
123/90.17
2005/0022765 A1 2/2005 Takenaka et al.
2009/0288624 A1 11/2009 Schafer et al.
2013/0300071 A1* 11/2013 Teusch B23B 31/028
279/9.1

FOREIGN PATENT DOCUMENTS

EP 0902169 B1 6/2002

OTHER PUBLICATIONS

International Search Report for International Application No. PCT/
DE2016/200414 dated Dec. 14, 2016.

* cited by examiner

Primary Examiner — Zelalem Eshete

(74) *Attorney, Agent, or Firm* — Brooks Kushman P.C.

(57) **ABSTRACT**

An electrically-actuatable camshaft adjuster includes an
adjustment gear which has a drive wheel with an external
toothing. The adjustment gear also has an additional ring-
shaped component which is solidly screwed to the drive
wheel. In particular, the drive wheel has internal threading
into which outer threading of the ring-shaped component is
screwed.

11 Claims, 1 Drawing Sheet

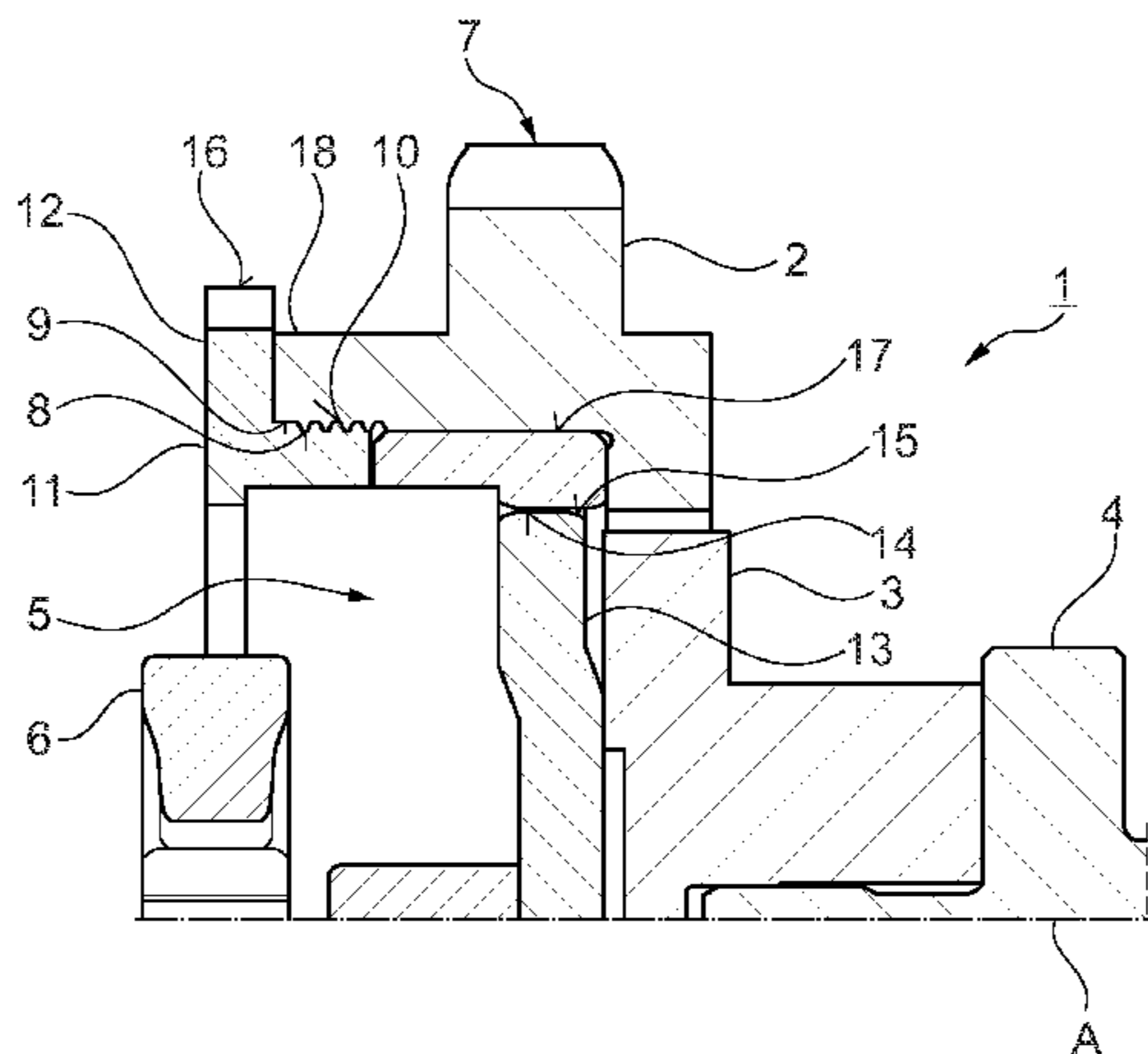

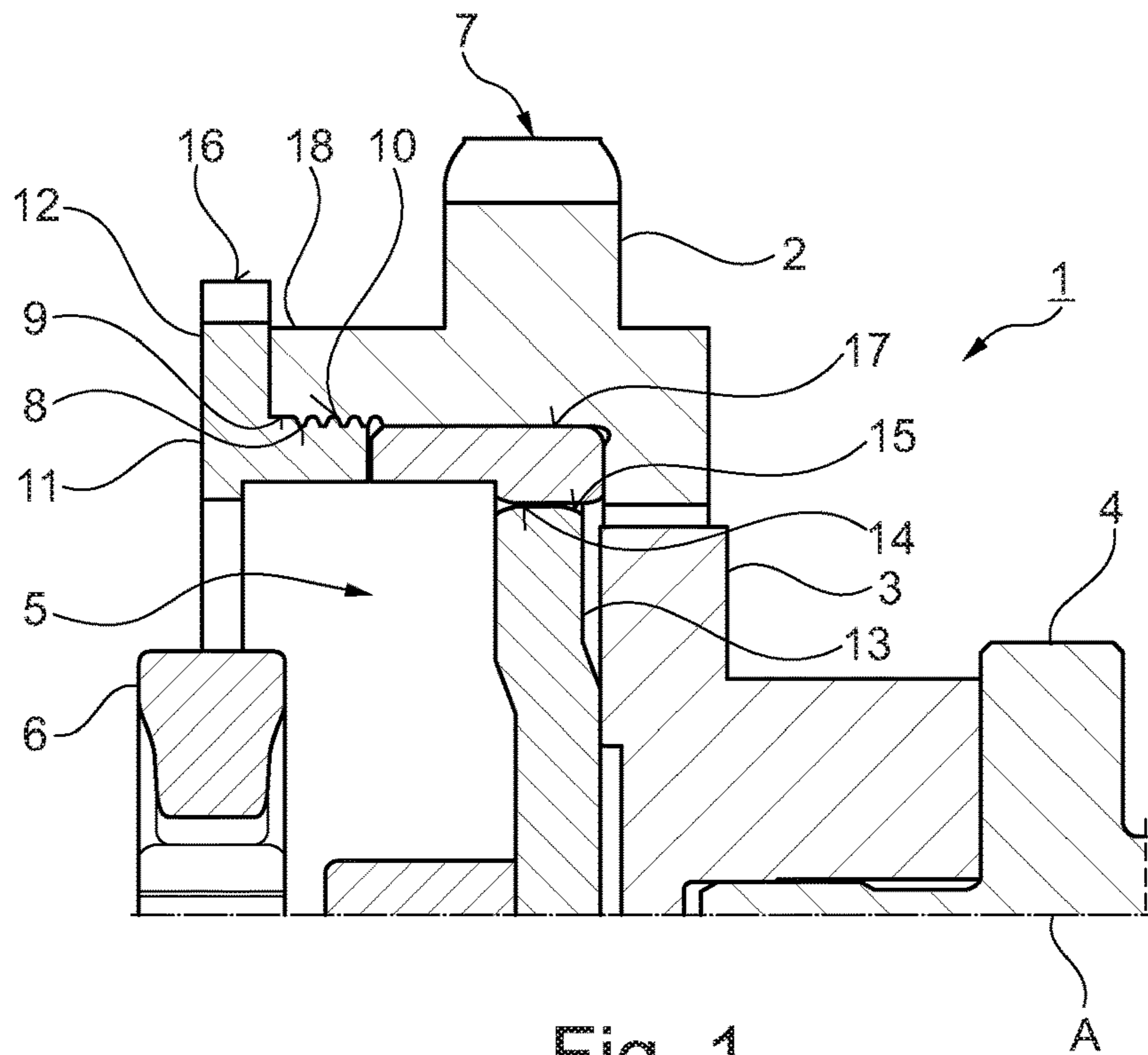

Fig. 1

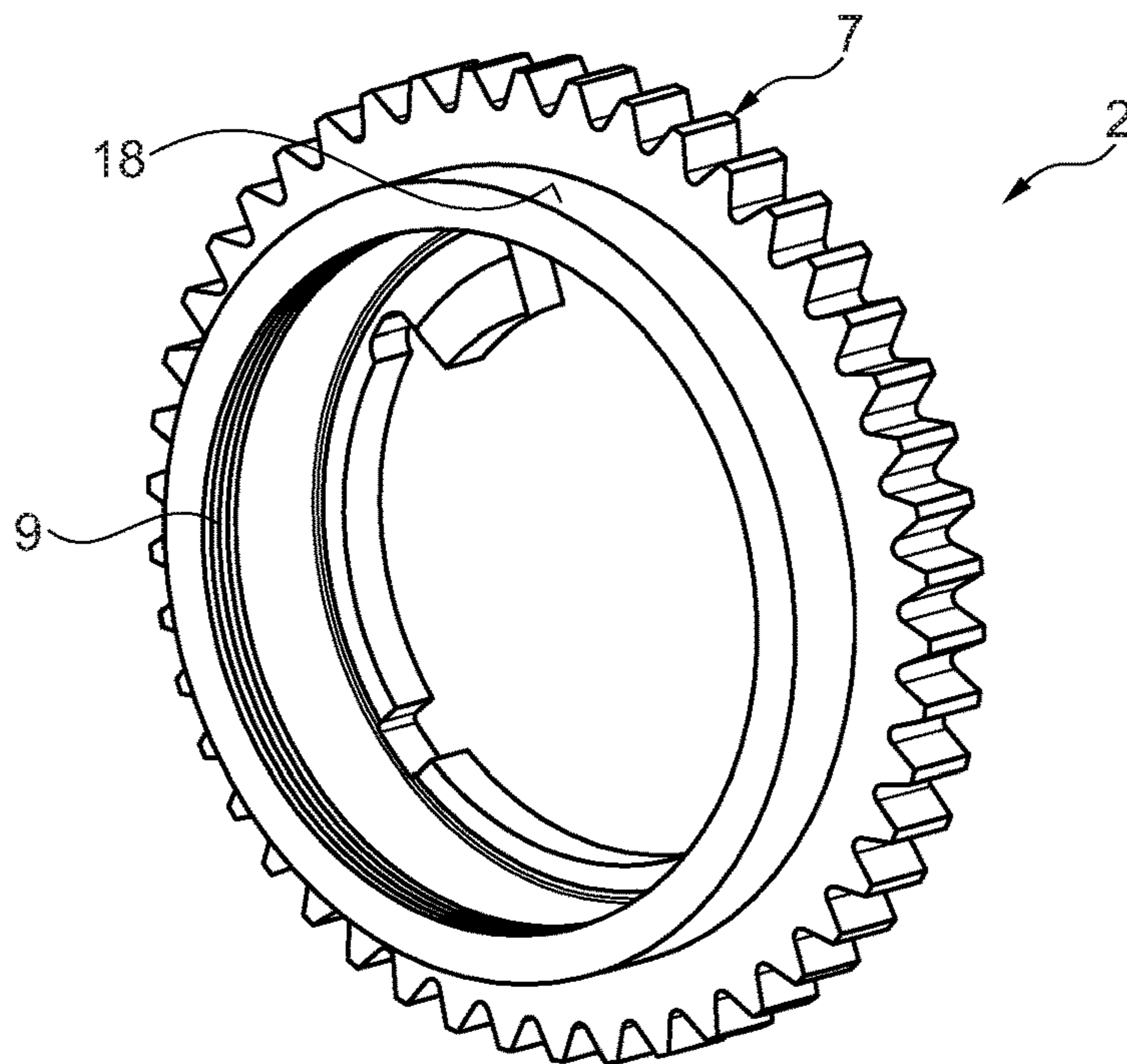

Fig. 2

1

CAMSHAFT ADJUSTER

CROSS-REFERENCE TO RELATED
APPLICATIONS

This application is the U.S. National Phase of PCT/DE2016/200414 filed Sep. 2, 2016, which claims priority to DE 102015217292.9 filed Sep. 10, 2015, the entire disclosures of which are incorporated by reference herein.

TECHNICAL FIELD

This disclosure relates to a camshaft adjuster suitable for an internal combustion engine, which has an adjustment gearing.

BACKGROUND

A generic camshaft adjuster is known, for example, from EP 1 718 846 B1. This camshaft adjuster can be actuated electrically, and has a three-stage planetary gearing, specifically a planetary gearing that functions as an adjustment gearing. A drive wheel of the camshaft adjuster is screwed to a stop ring. Rivet attachments, welding, and caulking are given as alternative attachment methods in EP 1 718 846 B1.

Further constructions of electrically actuatable camshaft adjusters are known, for example, from DE 102 48 355 A1. A brushless direct current motor with a permanent magnet rotor is provided as the electrical drive therein.

A combination camshaft adjuster and compensating shaft in an internal combustion engine is known from U.S. Pat. No. 5,327,859 A. A generic camshaft adjuster is described, by way of example, in WO 2006/074 732 A1. EP 0 902 169 B1 describes a further camshaft adjuster.

An object of this disclosure is to further develop a camshaft adjuster for an internal combustion engine that has an adjustment gearing that can be actuated electrically, in particular regarding a beneficial construction with regard to installation.

SUMMARY

This problem is solved in accordance with embodiments of the disclosure including a camshaft adjuster described herein.

The camshaft adjuster comprises an adjustment gearing, which has a drive gear with an outer toothing, and a further annular component can be securely screwed to the drive gear. In accordance with this disclosure, the drive gear has an internal threading that is concentric to its axis of rotation, into which an outer threading of the further annular component is screwed. The camshaft adjuster may be actuated electrically, but it can, however, be actuated in theory by other means, in particular hydraulically.

The further annular component, which is securely screwed onto the drive wheel that has an external toothing, is a drive ring gear with an inner toothing in an exemplary design, and may have an integral design. This drive ring gear functions in particular as a component of a planetary gearing provided as an adjustment gearing, i.e. a three-stage planetary gearing.

In contrast to known solutions, the drive ring gear according to one embodiment is screwed to the drive gear, in particular a chain wheel, by means of a single screw. This construction allows for a quick and precise installation. There is no need for a front cover on the assembly comprising the drive gear and further annular components. The

2

mechanical tensions and axial deformations are significantly reduced in comparison with assemblies that have numerous screws. In addition to the installation, preparation steps for the drive gear are also simplified in that, in particular, there is no longer any need to create numerous threaded holes. Through the elimination of individual threaded holes distributed on the circumference, the assembly comprising the drive gear and further annular components is particularly robust with respect to crack formation occurring at the screwing points, wherein the drive gear is particularly suited for heat treatment processes, in particular inductive tempering.

In an advantageous design, the further annular component screwed into the drive gear, e.g. the drive ring gear, has an actuation contour for a tool on its circumference, which extends radially over a circumferential surface of the drive gear. The surface of the drive gear (e.g., the cylindrical circumferential surface) lies radially inside the outer toothing of the drive gear. Likewise, the actuation contour formed on the further annular component may be disposed inside the outer toothing of the drive gear. The actuation contour thus lies—with respect to the central axis of the drive gear and the further annular component—radially between the cylindrical circumferential surface and the outer threading of the drive gear. The drive gear can be used to drive the camshaft using a tensioning device, or to drive the camshaft via gear teeth, in particular by means of an upright shaft.

According to an embodiment, the further annular component, e.g. the drive ring gear, has a centering contour that corresponds to a hole in the drive gear. It is thus possible to securely screw the further annular component to the drive gear and to center it in relation to the drive gear in a single work step. The centering contours of the further annular component and the drive gear may be disposed axially between a flange and the outer threading on the further annular component.

There may be at least one plane perpendicular to the central axis of the adjustment gearing and thus to the central axis of the drive gear, which intersects both the cylindrical circumferential surface as well as the centering contour of the drive gear. The entire camshaft adjuster is thus particularly compact, in particular in the axial direction of the camshaft.

Additional securement may be provided to ensure a secure screw connection. As a result, the screw connection can no longer be loosened or released by high alternating torques that may occur during operation of the camshaft adjuster. By way of example, the threading may become compressed when screwed together, such that the screw connection can no longer be released. Alternatively or additionally, the drive ring gear and the drive gear may have end walls that are axially adjacent to one another and have a surface structure that increases friction or provides an additional form fit through the edges thereof.

Separate screws may be needed for the screwing, because the screw connection is formed solely by the drive ring gear and the drive gear components. The drive gear may be screwed directly to the drive ring gear. The drive gear and drive ring gear may have an integral design for this.

Numerous windings of the screw connection are necessary for a secure screwing. At least four windings may be provided for.

The screw connection may be disposed on the side of the drive gear facing away from the camshaft with respect to the outer toothing. The installation can thus take place in a simple manner at the end, where there is sufficient space and

engagement surface for a tool. In a further development, the drive gear has an axial stop for the drive ring gear.

BRIEF DESCRIPTION OF THE DRAWINGS

An exemplary embodiment shall be described in greater detail below on the basis of the drawings. Therein:

FIG. 1 shows a camshaft adjuster that can be actuated electrically, in a simplified sectional view, and

FIG. 2 shows a drive gear of the camshaft adjuster according to FIG. 1 in a perspective view.

DETAILED DESCRIPTION OF THE DRAWINGS

An electric camshaft adjuster for an internal combustion engine, e.g. a diesel or gasoline engine, indicated on the whole with the reference symbol 1, has a chain wheel serving as the drive gear 2, and an output drive gear 3 that is concentric thereto, which is securely connected to a camshaft 4. When the internal combustion engine is in operation, the camshaft 4 rotates, as long as the camshaft adjuster 1 is not actuated, at one half of the rotational rate of the crankshaft of the internal combustion engine. The camshaft adjuster 1 may be used for adjusting the timing of the intake and exhaust valves of the internal combustion engine. With regard to the principle functions of the camshaft adjuster 1, reference is made to the prior art cited in the introductory portion of the description. Because the camshaft adjuster 1 is electric, it can be adjusted not only when the internal combustion engine is in operation, but also prior to start-up.

An adjustment gearing 5, specifically a planetary gearing in the form of a three-stage planetary gearing, is merely indicated in FIG. 1. The rotation of the shaft of an electric motor, not shown, is introduced via an Oldham disk 6 into the adjustment gearing 5 of the camshaft adjuster 1. The Oldham disk 6 is a component of an Oldham coupling, e.g. a compensating coupling, which allows for a radial offset between an input drive shaft and an output drive shaft. As long as the shaft of the electric motor, and thus the Oldham disk 6, rotates at the same rate as the camshaft 4, there are no phase shifts between the crankshaft (not shown) and the camshaft 4 of the internal combustion engine. Such phase shifts only occur when the shaft of the electric motor that functions as an adjustment shaft for the camshaft adjuster 1, rotates at a different rate than the camshaft 4, wherein the adjustment gearing 5 is configured as a reduction gearing.

The annular drive gear 2 has an outer toothing 7, by means of which the drive gear 2 can be driven using a tensioning device, for example a chain. A centering contour 9 in the form of a hole and an inner threading 8 are located—behind one another axially—on the inner circumference of the drive gear 2. The centering contour 9 extends over a shorter region than the inner threading 8 in the axial direction thereby.

The inner threading 8 corresponds to an outer threading 10 on a further annular component 11, specifically a drive ring gear, which is connected to the drive gear 2 for conjoint rotation therewith. The drive ring gear 11 has a substantially sleeve-like shape, wherein there is a flange 12 on the end surface of the drive ring gear 11 facing away from the camshaft 4, which is an integral component of the drive ring gear 11. The diverse gearing components, disposed radially inside the drive ring gear 11, are merely indicated in FIG. 1 by a multi-part drive element 13. Individual components of the drive element 13 are connected to one another with contact pressure surfaces 14, 15.

In order to screw the drive ring gear 11 into the drive gear 2, an actuation contour 16, e.g. in the form of a hexagonal contour, is provided on the flange 12 of the drive ring gear 11, and the drive gear 2 and the drive ring gear 11 can be screwed together with a tool, not shown. At the same time, the centering contour 9 of the drive gear 2, in the form of a hole, together with a corresponding centering contour of the drive ring gear 11, ensures a precise coaxial positioning of the drive gear 2 and the drive ring gear 11. The drive gear 2, which is a chain wheel, has an integral design, and is inductively tempered, at least on parts of its surface.

The actuation contour 16 of the drive ring gear 11 is disposed radially outside a cylindrical circumferential surface of the drive gear 2, indicated by the numeral 18, and radially inside the outer toothing 7 of the drive gear 2. A single plane, perpendicular to the rotational axis of the camshaft 4 indicated by the letter A, i.e. the central axis of the adjustment gearing 5, intersects both the actuation contour 16 of the drive ring gear 11, as well as the Oldham disk 6, such that the Oldham coupling can be accommodated in a space saving manner, partially engaging in the adjustment gearing 5.

A further plane, parallel to the specified plane, intersects both the cylindrical circumferential surface 18 as well as the centering contour 9 of the drive gear 2. A radial bearing 17, in the form of a sliding bearing, is located radially inside the outer toothing 7 of the drive gear 2, and the drive element 13, in the form of an output drive gear, is supported in the drive gear 2.

As a result of the overall compact construction of the camshaft adjuster 1, undesired torques are introduced into the adjustment gearing 5 only to a very limited extent during operation thereof. The inner threading 8 as well as the outer threading 10 of the drive ring gear 11 interacting therewith, are oriented such that the screw connection between these parts 2, 11 is tightened when the internal combustion engine is in operation, i.e. when the camshaft 4 is driven.

LIST OF REFERENCE SYMBOLS

- 1 camshaft adjuster
- 2 drive gear
- 3 output drive gear
- 4 camshaft
- 5 adjustment gearing
- 6 Oldham disk
- 7 outer toothing
- 8 inner threading of the drive gear
- 9 centering contour of the drive gear, hole
- 10 outer threading of the drive ring gear
- 11 further annular component, drive ring gear
- 12 flange
- 13 output drive element
- 14 contact pressure surface
- 15 contact pressure surface
- 16 actuation contour
- 17 radial bearing
- 18 cylindrical circumferential surface
- A axis of rotation

The invention claimed is:

1. A camshaft adjuster that has an adjustment gearing, comprising a drive gear with an outer toothing configured to be driven by a tensioning device, and a further annular component securely screwed thereto, wherein the drive gear has an inner threading concentric to its axis of rotation, into which an outer threading of the further annular component is screwed;

5

wherein the further annular component is a drive ring gear with an inner tothing;

wherein the further annular component has a centering contour corresponding to a central hole of the drive gear; and

wherein the central hole is disposed between a flange and the outer threading of the drive ring gear.

2. The camshaft adjuster according to claim 1, wherein the adjustment gearing includes a planetary gearing, and the drive ring gear is a component of the planetary gearing.

3. The camshaft adjuster according to claim 1, wherein the further annular component has an actuation contour on its circumference for a tool, the actuation contour extending radially over a circumferential surface of the drive gear.

4. The camshaft adjuster according to claim 3, wherein the actuation contour is disposed radially inside the outer tothing of the drive gear.

5. The camshaft adjuster according to claim 1, wherein there is a plane that is perpendicular to a central axis (A) of the adjustment gearing, which intersects both a cylindrical circumferential surface of the drive gear as well as the centering contour of the drive gear.

6. The camshaft adjuster according to claim 1, wherein the screw connection of the inner threading and the outer threading is reinforced by additional securing structure.

7. A camshaft adjuster comprising:

adjustment gearing configured to rotate about a central axis;

a drive gear having outer tothing configured to be driven by a tensioning device, and an inner-facing surface facing toward the central axis, the inner-facing surface defining inner threading, and the drive gear defining a central hole; and

6

a drive ring gear coupled to the adjustment gearing and having an outer-facing surface facing away from the central axis, the outer-facing surface defining outer threading mating with the inner threading such that the drive gear and the drive ring gear are coupled together via a screwing engagement, wherein the drive ring gear includes a centering contour corresponding to the central hole, wherein the central hole is disposed between a flange and the outer threading of the drive ring gear.

8. The camshaft adjuster of claim 7, wherein the adjustment gearing includes planetary gearing.

9. The camshaft adjuster of claim 7, wherein the drive ring gear defines a circumference having an actuation contour configured to receive a tool, the actuation contour is radially outward of a circumferential surface of the drive gear.

10. The camshaft adjuster of claim 9, wherein the actuation contour is radially inward of the outer tothing of the drive gear.

11. A camshaft adjuster comprising:

a drive gear having an outer surface configured to be driven by a chain, and an inner-facing surface defining inner threading, the drive gear defining a central hole; planetary gearing including, an outer drive ring gear, the drive ring gear having an outer-facing surface defining outer threading mating with the inner threading such that the drive gear and the drive ring gear are coupled together via a screwing engagement, wherein the drive ring gear includes a centering contour corresponding to the central hole, wherein the central hole is disposed between a flange and the outer threading of the drive ring gear.

* * * * *