

US010385643B2

(12) **United States Patent**
Guidry

(10) **Patent No.:** **US 10,385,643 B2**
(45) **Date of Patent:** ***Aug. 20, 2019**

(54) **FRACTURING MANIFOLD SYSTEMS AND METHODS**

(71) Applicant: **Cameron International Corporation**,
Houston, TX (US)

(72) Inventor: **Kirk P. Guidry**, Cypress, TX (US)

(73) Assignee: **Cameron International Corporation**,
Houston, TX (US)

(*) Notice: Subject to any disclaimer, the term of this patent is extended or adjusted under 35 U.S.C. 154(b) by 0 days.

This patent is subject to a terminal disclaimer.

(21) Appl. No.: **16/154,461**

(22) Filed: **Oct. 8, 2018**

(65) **Prior Publication Data**

US 2019/0040707 A1 Feb. 7, 2019

Related U.S. Application Data

(63) Continuation of application No. 15/375,558, filed on Dec. 12, 2016, now Pat. No. 10,094,195, which is a
(Continued)

(51) **Int. Cl.**
E21B 33/03 (2006.01)
E21B 33/068 (2006.01)
(Continued)

(52) **U.S. Cl.**
CPC **E21B 33/068** (2013.01); **E21B 17/05**
(2013.01); **E21B 33/03** (2013.01); **E21B 34/02**
(2013.01);
(Continued)

(58) **Field of Classification Search**
CPC combination set(s) only.
See application file for complete search history.

(56) **References Cited**

U.S. PATENT DOCUMENTS

1,615,536 A 1/1927 Del Mar
3,233,668 A 2/1966 Hamilton et al.

(Continued)

FOREIGN PATENT DOCUMENTS

CA 2178856 A1 12/1997
CN 201461291 U 5/2010

(Continued)

OTHER PUBLICATIONS

Perry's Chemical Engineers' Handbook, 6th ed., Robert H. Perry and Don Green (eds.), 1984, cover, title page, copyright page, and pp. 6-1, 6-41, 6-45, 6-46, 6-54, and 6-55, McGraw-Hill Inc., New York, United States of America.

(Continued)

Primary Examiner — Cathleen R Hutchins

Assistant Examiner — Ronald R Runyan

(74) *Attorney, Agent, or Firm* — Eubanks PLLC

(57) **ABSTRACT**

A fracturing system is provided. In one embodiment, the fracturing system includes a fracturing manifold for routing fracturing fluid to multiple wells. The fracturing manifold can be coupled via fluid conduits to fracturing trees installed at the wells. In some cases, a fracturing tree is coupled to the fracturing manifold by a pair of goat heads in fluid communication with each other via at least one rigid fluid conduit. The fracturing manifold can include a trunk line that provides fracturing fluid to multiple outlet branches, which can include valves for controlling flow of fracturing fluid to wells downstream of the valves. Additional systems, devices, and methods are also disclosed.

14 Claims, 11 Drawing Sheets

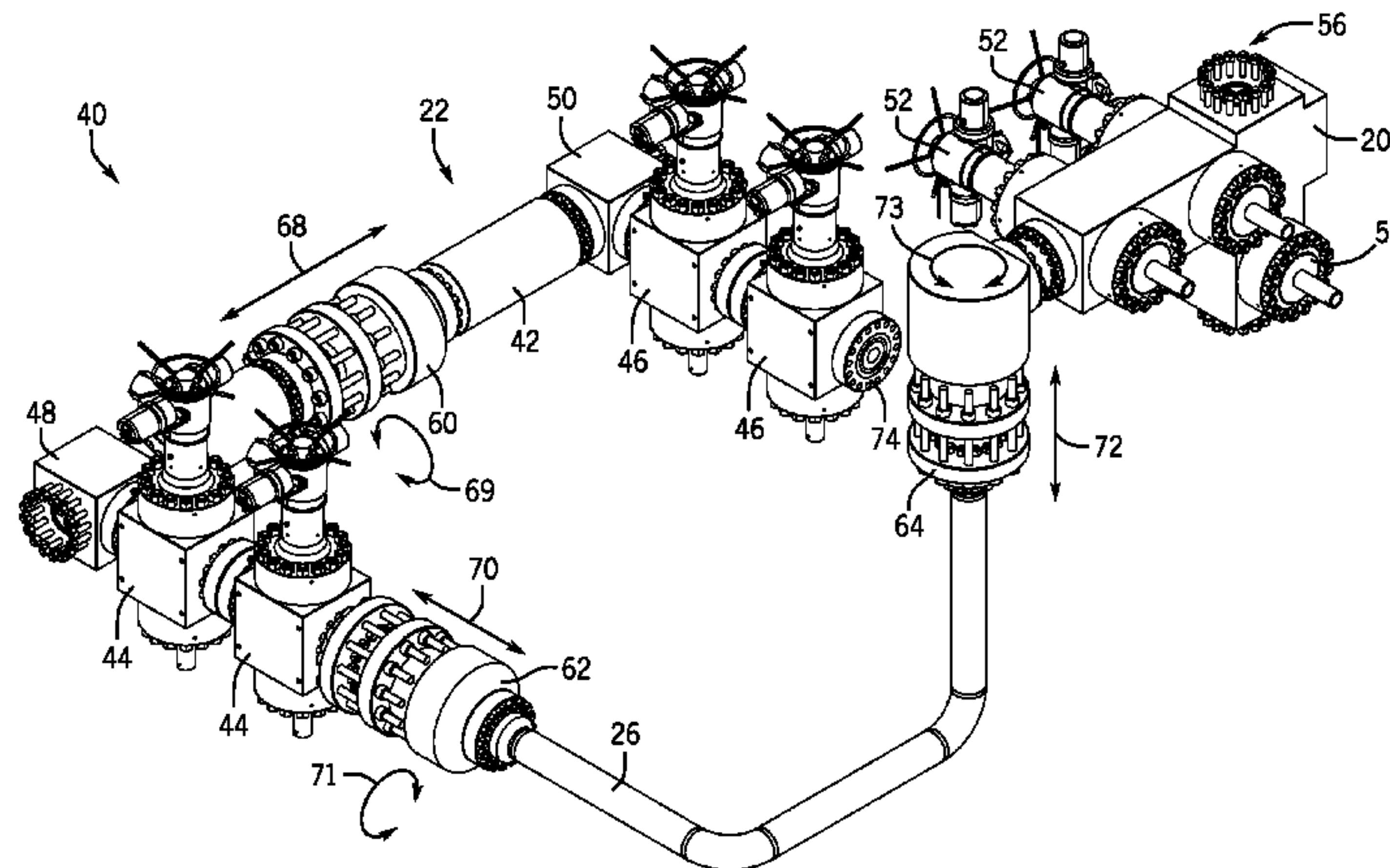

Related U.S. Application Data

continuation of application No. 14/752,864, filed on Jun. 27, 2015, now Pat. No. 9,518,430, which is a continuation of application No. 13/783,009, filed on Mar. 1, 2013, now Pat. No. 9,068,450, which is a continuation-in-part of application No. 13/243,252, filed on Sep. 23, 2011, now Pat. No. 8,978,763.

(60) Provisional application No. 61/759,127, filed on Jan. 31, 2013.

(51) **Int. Cl.**

E21B 43/26 (2006.01)
F16L 27/12 (2006.01)
F16L 15/02 (2006.01)
E21B 34/02 (2006.01)
E21B 17/05 (2006.01)
G05D 7/06 (2006.01)
E21B 41/00 (2006.01)

(52) **U.S. Cl.**

CPC **E21B 41/00** (2013.01); **E21B 43/26** (2013.01); **F16L 15/02** (2013.01); **F16L 27/12** (2013.01); **G05D 7/0664** (2013.01); **F16L 2201/30** (2013.01)

(56) **References Cited**

U.S. PATENT DOCUMENTS

3,993,100	A	11/1976	Pollard et al.
4,127,991	A	12/1978	Regan
4,355,961	A	10/1982	Riggs
4,366,864	A	1/1983	Gibson et al.
4,452,312	A	6/1984	Roblin
4,559,716	A	12/1985	Daughtry et al.
4,570,673	A	2/1986	Kendrick et al.
4,603,887	A	8/1986	Mayfield et al.
4,632,432	A	12/1986	Reneau
4,767,136	A	8/1988	Lehmann
4,998,756	A	3/1991	Hart
5,195,589	A	3/1993	Mota et al.
5,244,045	A	9/1993	Mota
6,003,604	A	12/1999	Wilkins
6,234,030	B1	5/2001	Butler
6,364,024	B1	4/2002	Dallas
8,398,122	B2	3/2013	Crompton et al.
8,839,867	B2	9/2014	Conrad
8,905,056	B2	12/2014	Kendrick
8,944,159	B2	2/2015	Guidry et al.
8,978,763	B2	3/2015	Guidry
9,068,450	B2	6/2015	Guidry
9,127,545	B2	9/2015	Kajaria et al.
9,222,345	B2	12/2015	Conrad
9,255,469	B2	2/2016	Conrad
9,518,430	B2	12/2016	Guidry
9,631,469	B2	4/2017	Guidry et al.
9,903,190	B2	2/2018	Conrad et al.
9,915,132	B2	3/2018	Conrad
9,932,800	B2	4/2018	Guidry
10,094,195	B2	10/2018	Guidry
2003/0205378	A1	11/2003	Wellington et al.
2003/0205385	A1	11/2003	Duhn et al.
2004/0251020	A1	12/2004	Smith
2006/0090891	A1	5/2006	McGuire et al.
2006/0207763	A1	9/2006	Hofman
2006/0237194	A1	10/2006	Donald et al.
2007/0125544	A1	6/2007	Robinson et al.
2007/0227722	A1	10/2007	Atencio
2008/0083530	A1*	4/2008	Boyd E21B 33/068 166/90.1
2008/0083539	A1	4/2008	Hickie

2008/0257540	A1	10/2008	McGuire et al.
2008/0277120	A1	11/2008	Hickie
2009/0090515	A1	4/2009	Chan et al.
2009/0114392	A1	5/2009	Tolman et al.
2009/0145597	A1	6/2009	Cherewyk
2009/0194273	A1	8/2009	Surjaatmadja et al.
2009/0261575	A1	10/2009	Bull et al.
2010/0025034	A1	2/2010	Donald et al.
2010/0032031	A1	2/2010	Neal
2010/0051261	A1	3/2010	Koleilat et al.
2010/0300672	A1	12/2010	Childress et al.
2011/0011599	A1*	1/2011	Nguyen E21B 33/068 166/386
2011/0048695	A1*	3/2011	Cherewyk E21B 21/062 166/90.1
2011/0048698	A1	3/2011	McGuire et al.
2011/0108275	A1	5/2011	Borak et al.
2011/0114320	A1	5/2011	Sponchia et al.
2011/0132596	A1	6/2011	Yeh et al.
2011/0259584	A1	10/2011	Broussard, II
2012/0152564	A1	6/2012	Peltier
2012/0181015	A1	7/2012	Kajaria et al.
2012/0181016	A1	7/2012	Kajaria et al.
2012/0181030	A1	7/2012	Kajaria et al.
2012/0242081	A1	9/2012	Keays et al.
2013/0032328	A1	2/2013	Guidry et al.
2013/0076026	A1	3/2013	Guidry
2014/0238683	A1	8/2014	Korach et al.
2015/0136383	A1	5/2015	Guidry et al.
2015/0159458	A1	6/2015	Tan et al.
2015/0275629	A1	10/2015	Hatton
2015/0354313	A1	12/2015	McClinton et al.
2016/0376865	A1	12/2016	Guidry et al.
2017/0138144	A1	5/2017	Christopherson et al.
2017/0350223	A1	12/2017	Guidry et al.
2018/0216436	A1	8/2018	Guidry et al.
2018/0291718	A1	10/2018	Conrad et al.
2018/0298735	A1	10/2018	Conrad
2019/0078412	A1	3/2019	Guidry et al.
2019/0093444	A1	3/2019	Guidry

FOREIGN PATENT DOCUMENTS

CN	201865597	U	6/2011
CN	102296945	A	12/2011
CN	202417461	U	9/2012
GB	2184149	A	6/1987
WO	2009154881	A1	12/2009

OTHER PUBLICATIONS

API Specification 6A: Specification for Wellhead and Christmas Tree Equipment, 17th ed., 1999, American Petroleum Institute, United States of America.

API Specification 6A: Specification for Wellhead and Christmas Tree Equipment, 19th ed., 2004, American Petroleum Institute, United States of America.

Catalog for Pressure Control Equipment, Feb. 1, 2005, WOODCO USA, Houston, Texas, United States of America.

Bommer, Paul, A Primer of Oilwell Drilling, 7th ed., 2008, cover, title page, copyright page, and pp. 177, 213, and 234, The University of Texas at Austin, United States of America.

Hall, James, et al., *Nitro Fluids, L.L.C. v. Cameron International Corporation*, Case IPR2019-00804, U.S. Pat. No. 9,903,190, Petition for Inter Partes Review filed Mar. 8, 2019.

Hall, James, et al., *Nitro Fluids, L.L.C. v. Cameron International Corporation*, Case IPR2019-00852, U.S. Pat. No. 9,932,800, Petition for Inter Partes Review filed Mar. 20, 2019.

Slayden, Bruce, et al., *Cameron International Corporation vs. NitroFluids L.L.C.*, Cameron's Opening '195 Patent Claim Construction Brief, United States District Court for the Southern District of Texas, Case No. 4-18-cv-02533, dated Mar. 21, 2019.

* cited by examiner

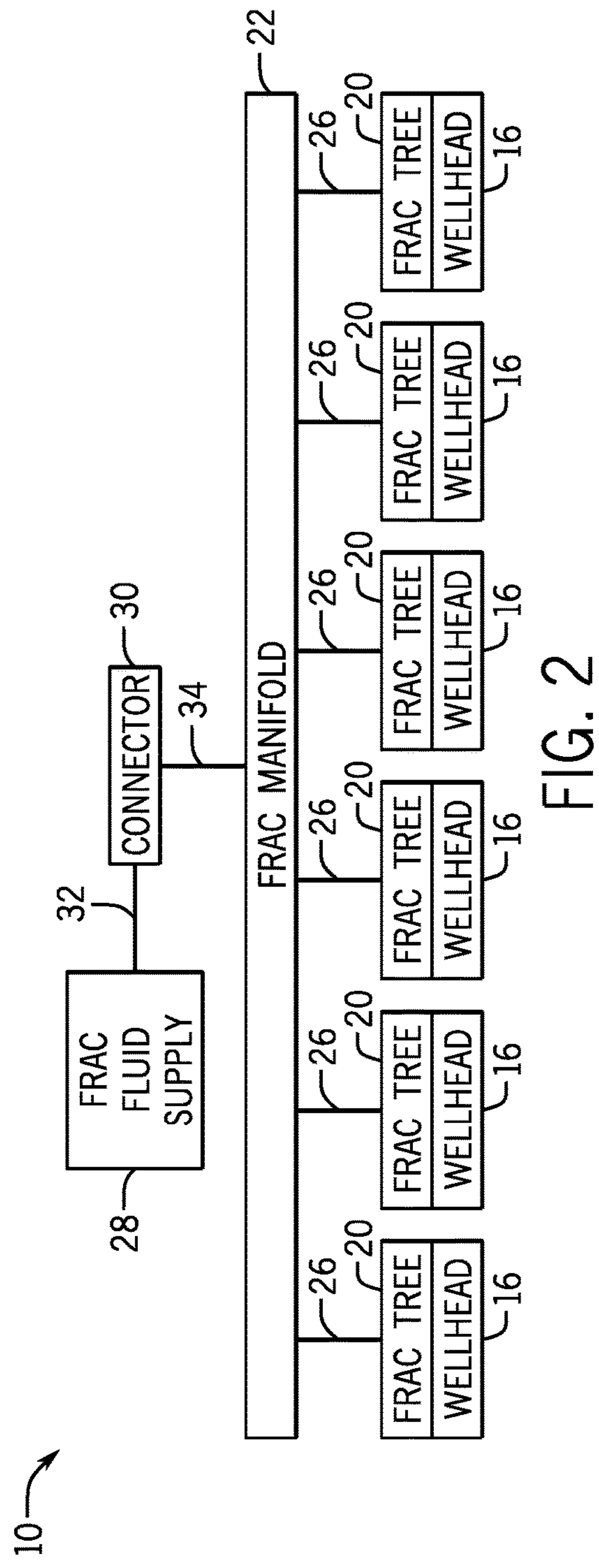
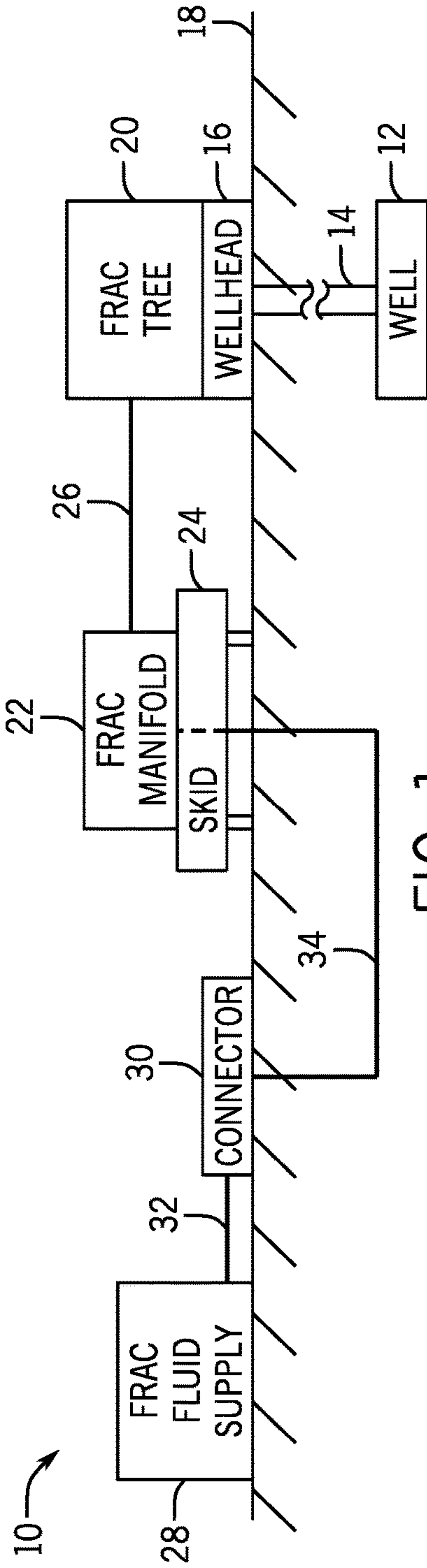

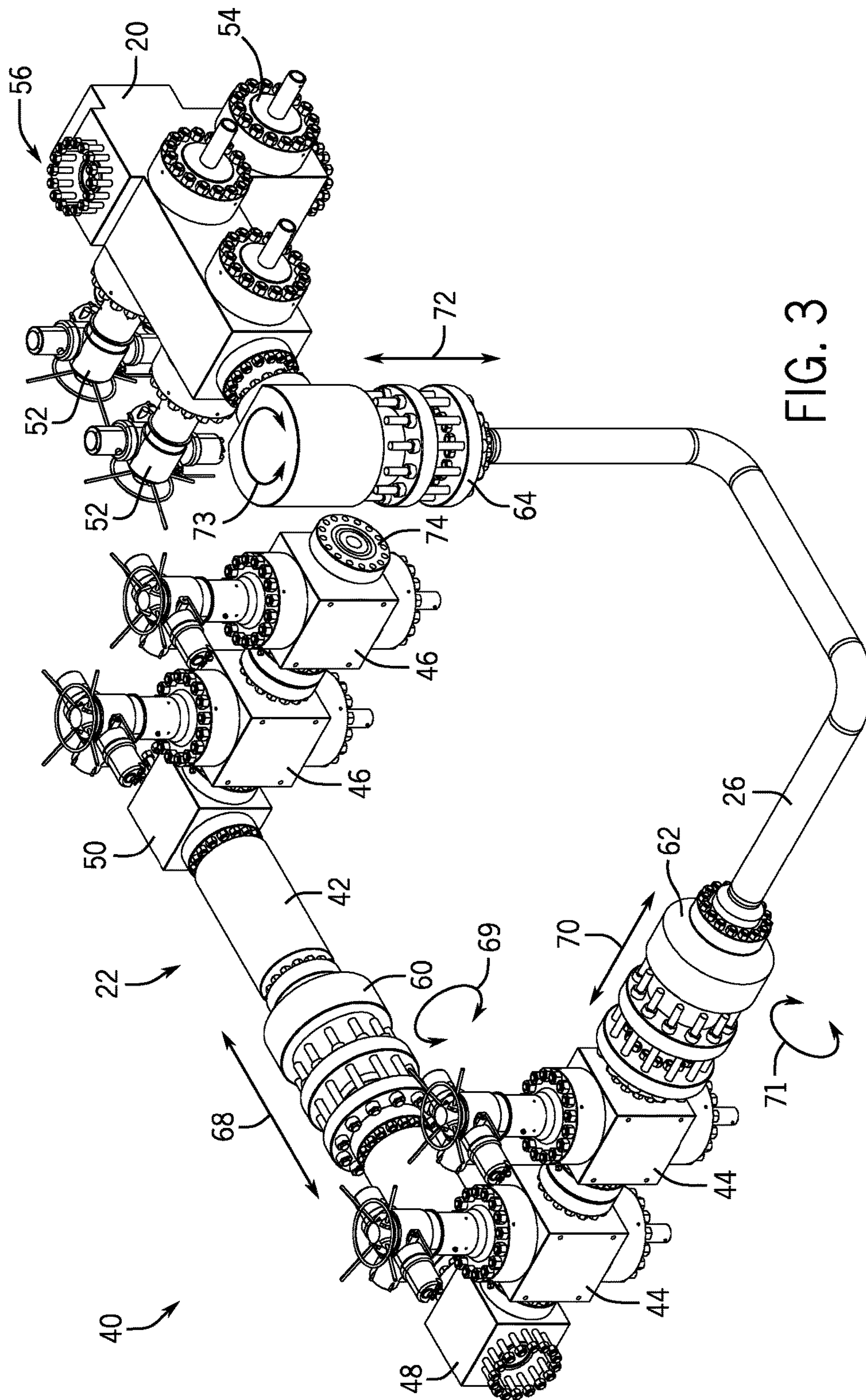
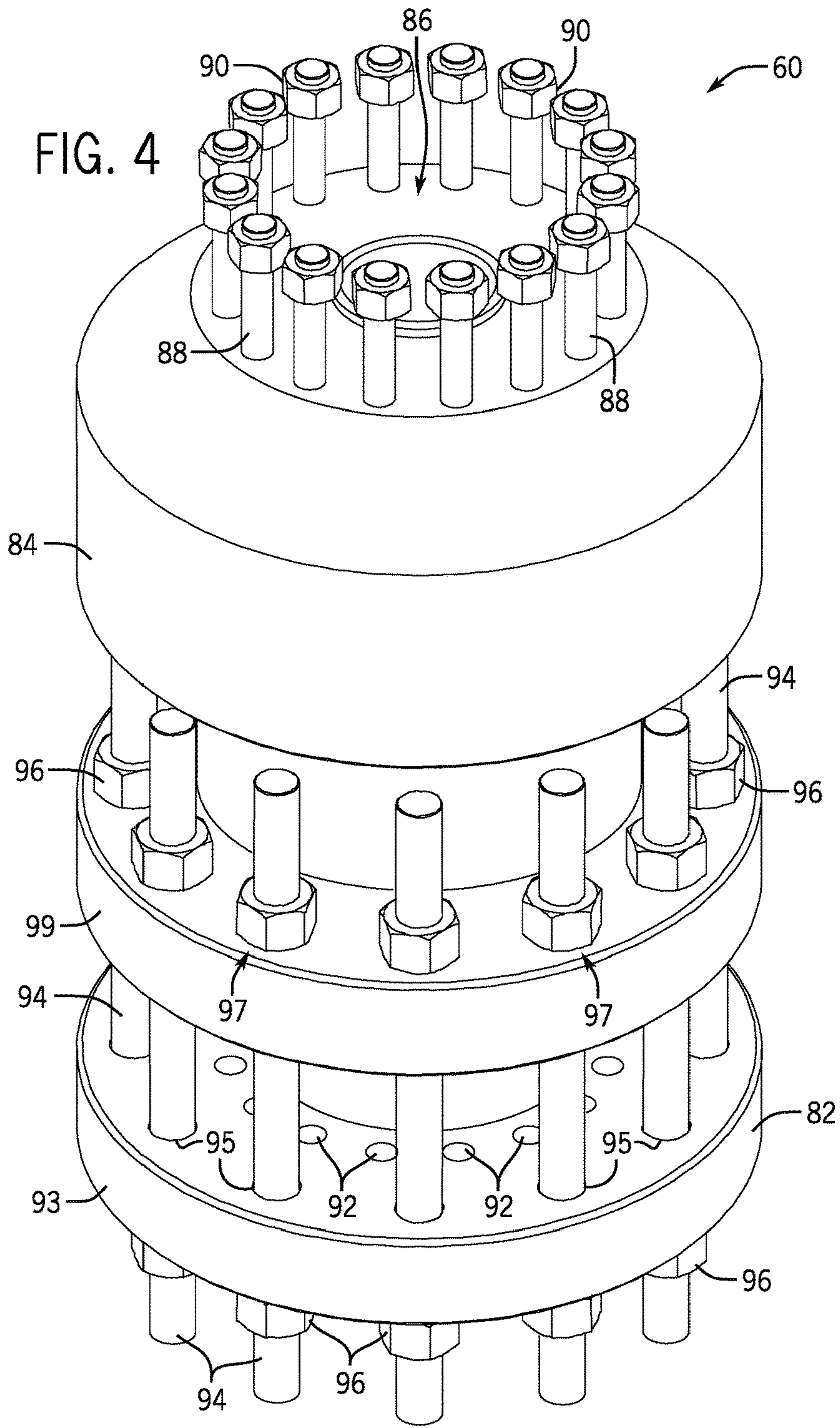

FIG. 3



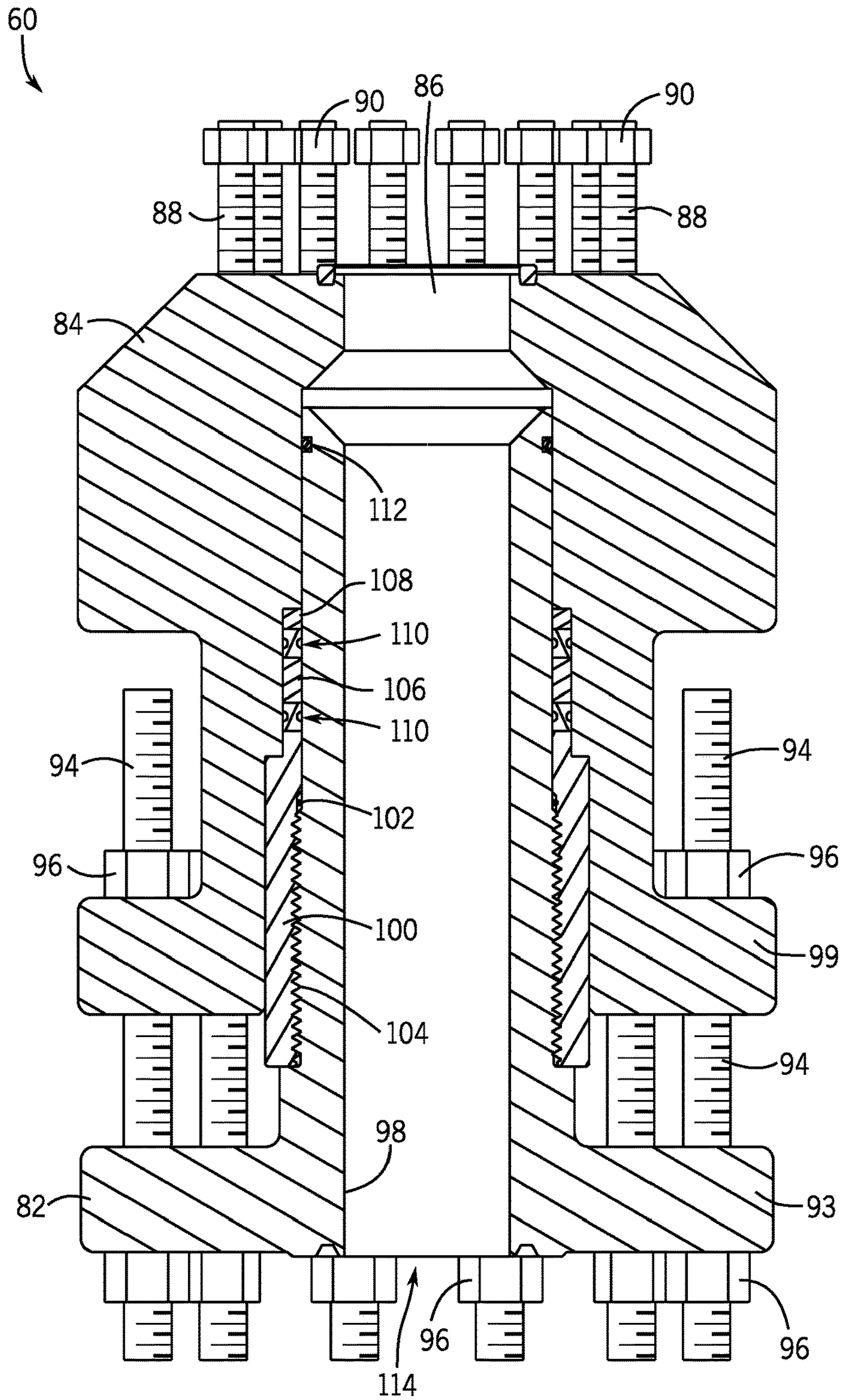

FIG. 5

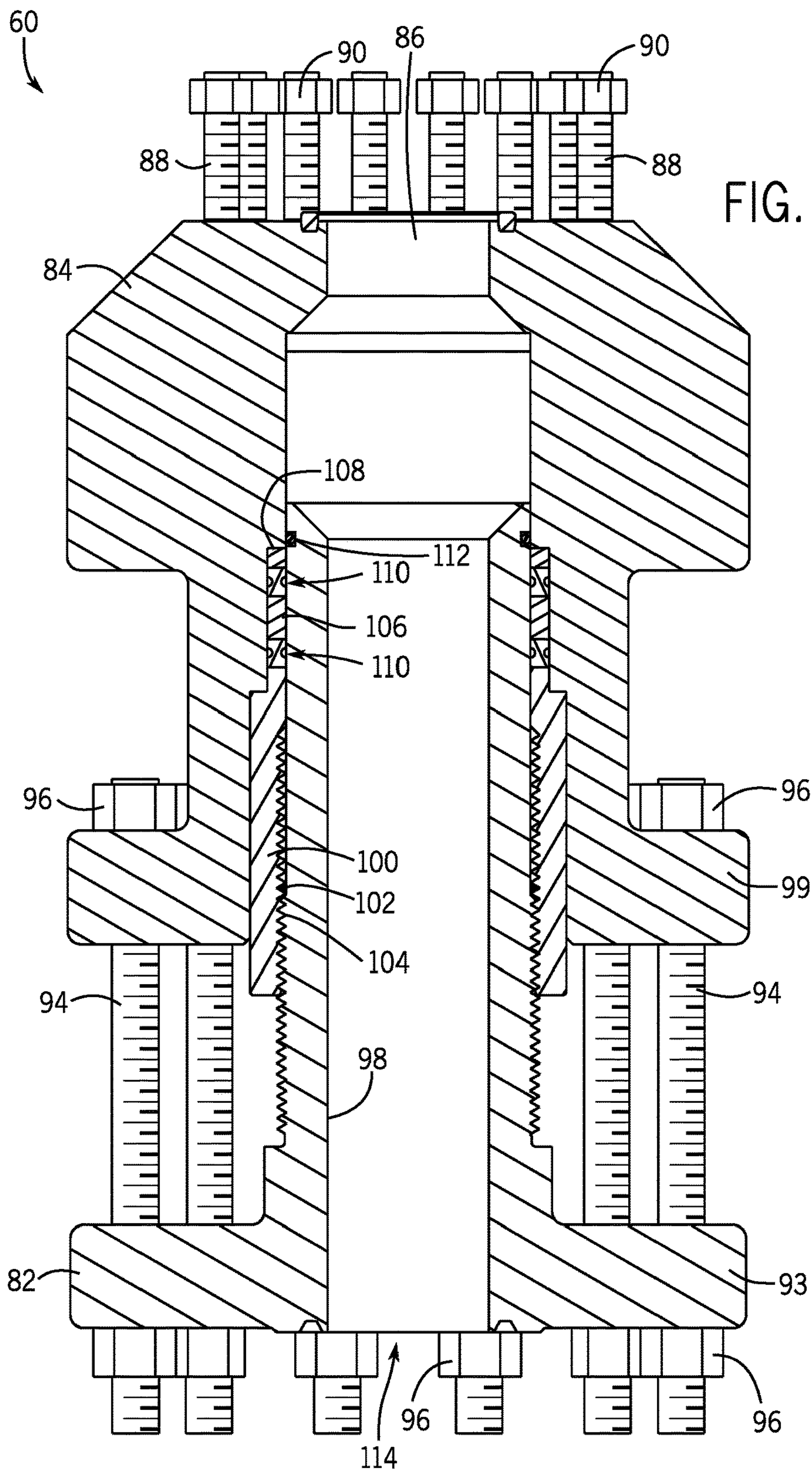
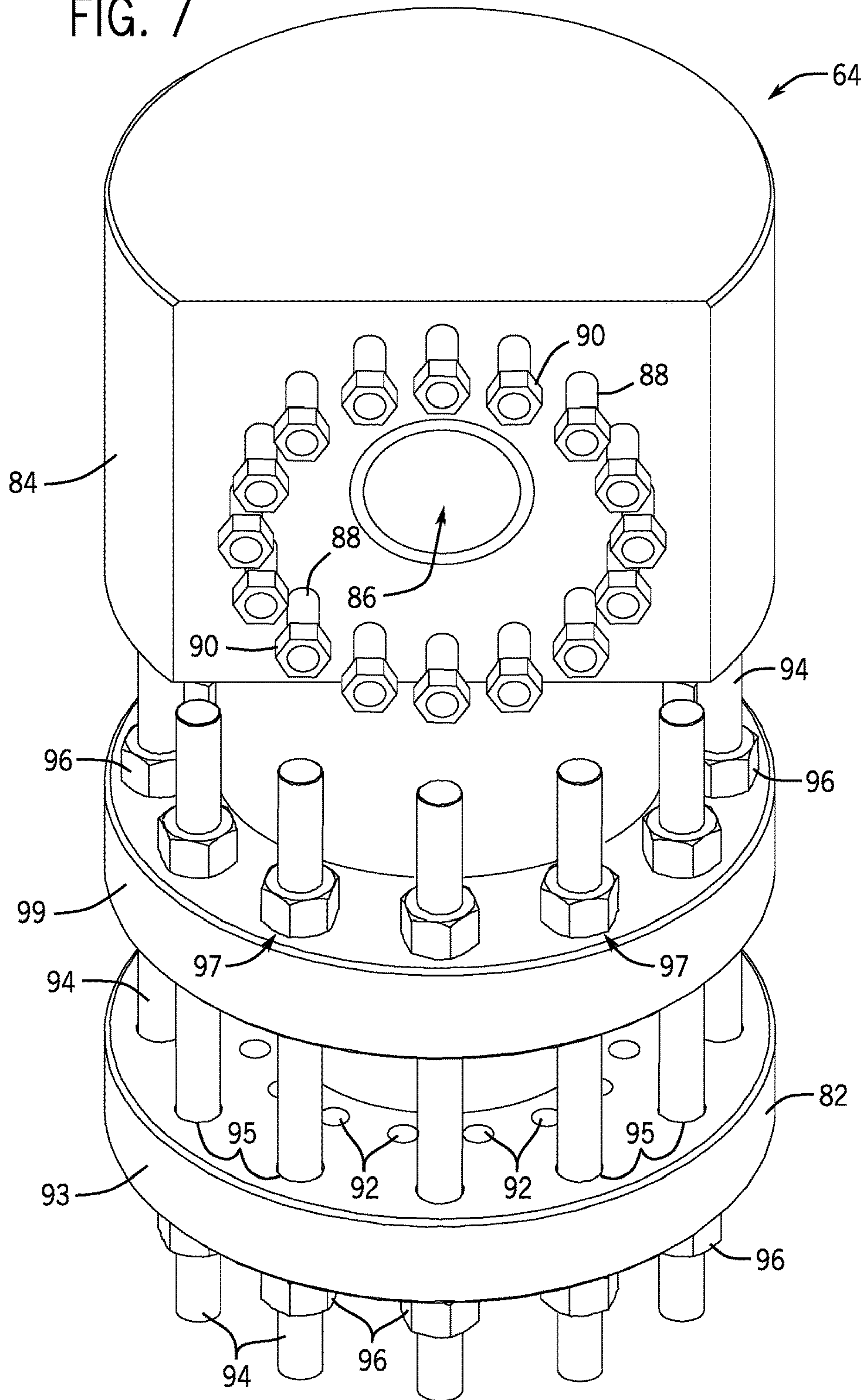

FIG. 6

FIG. 7



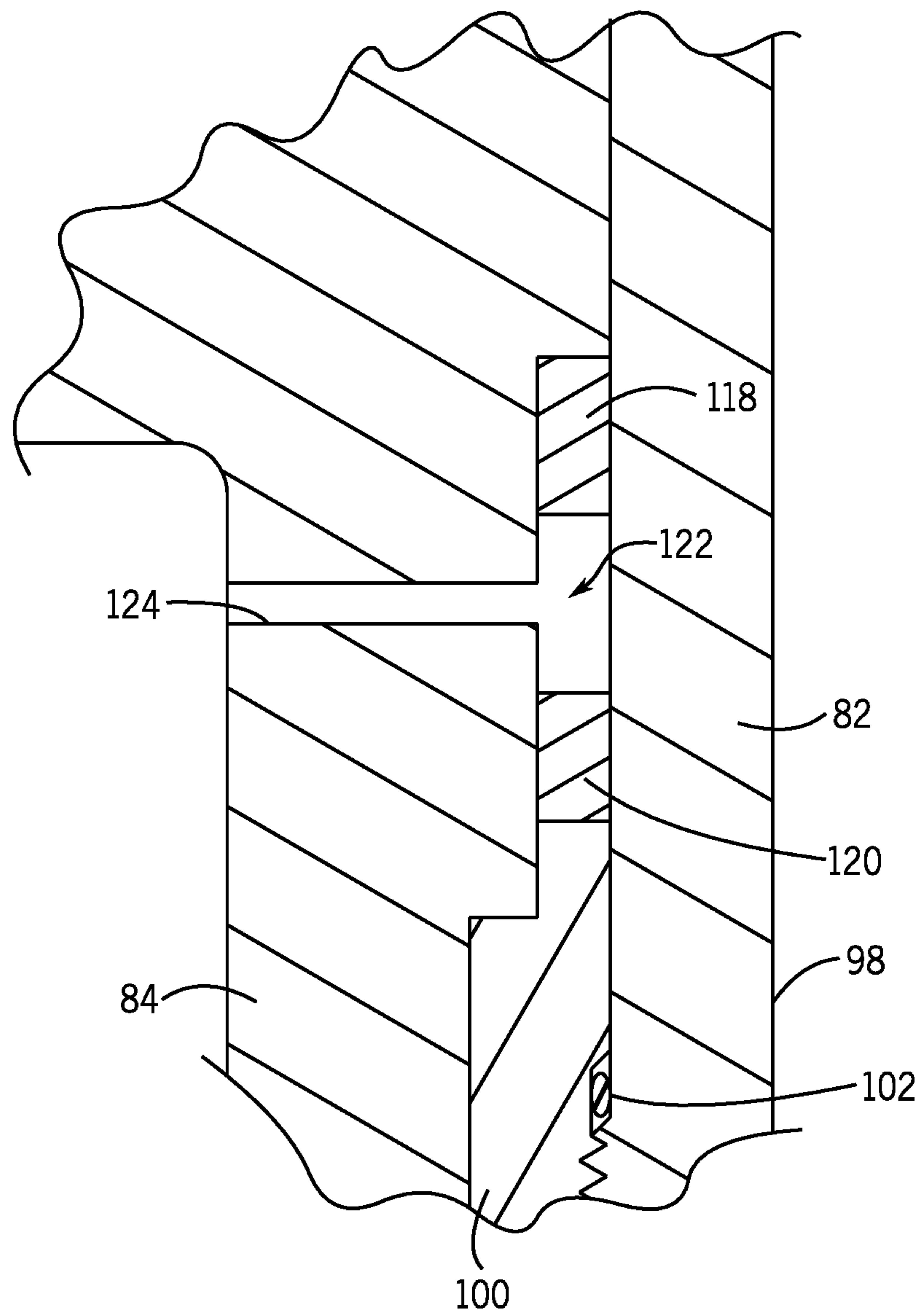

FIG. 8

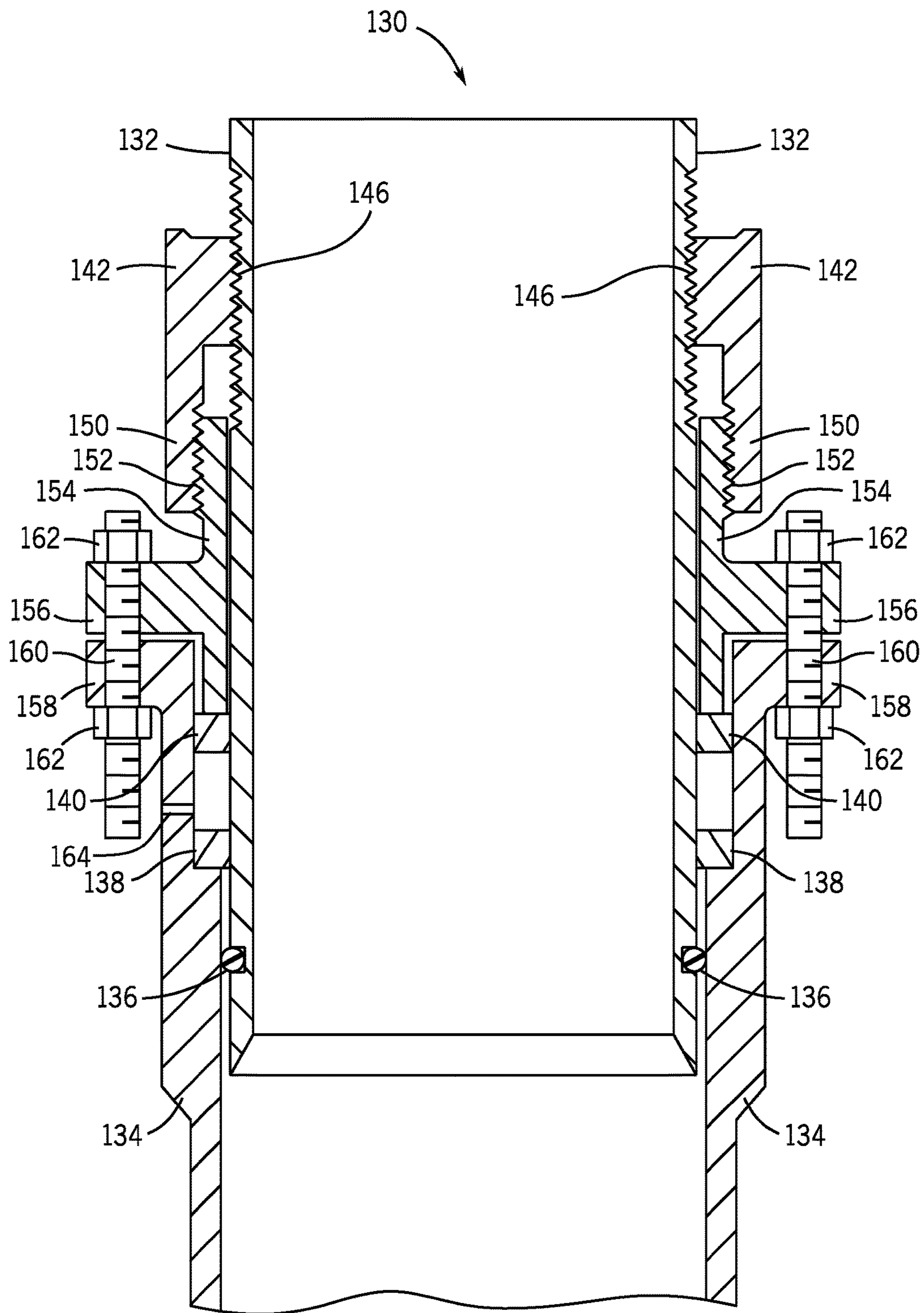

FIG. 9

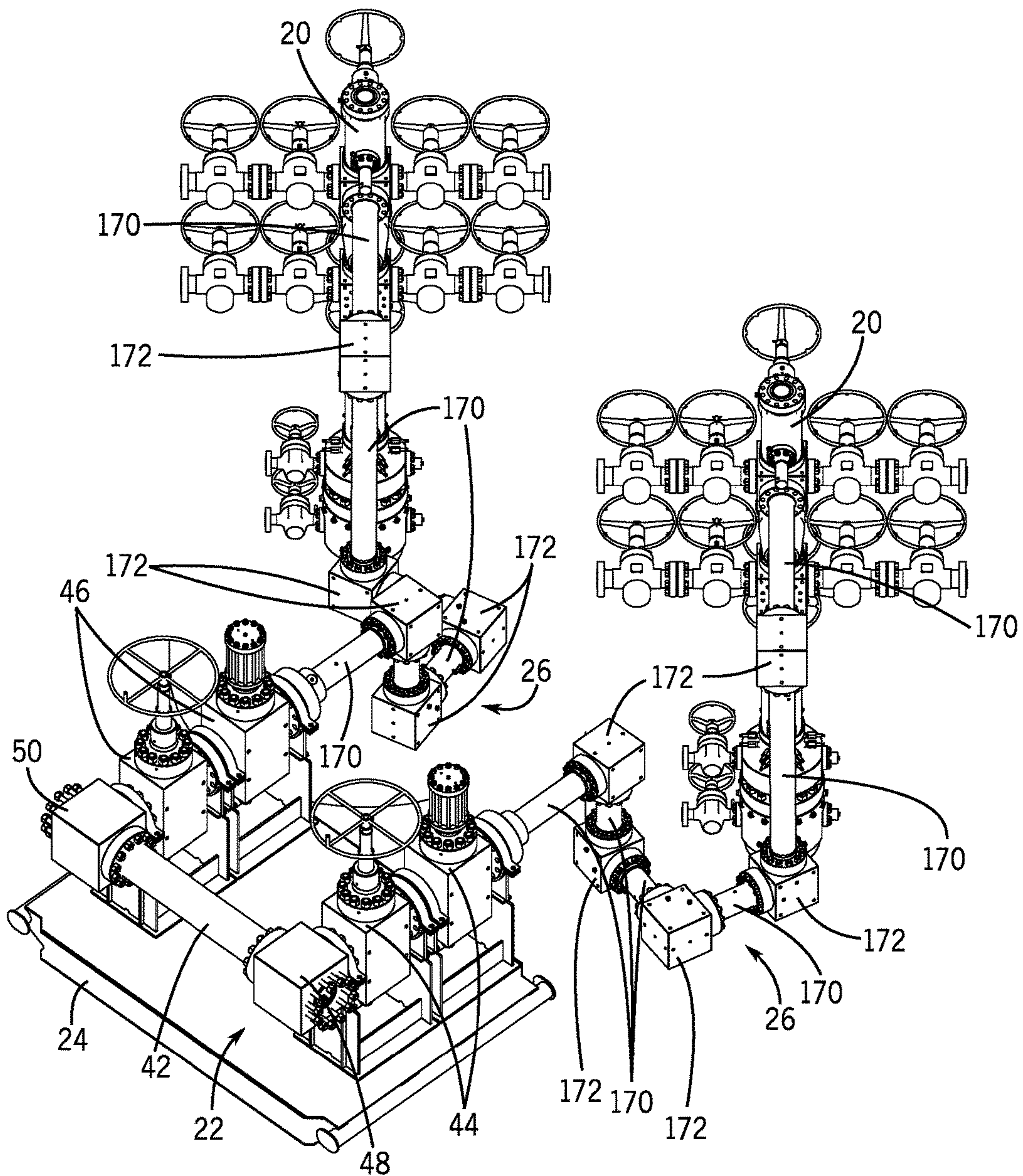
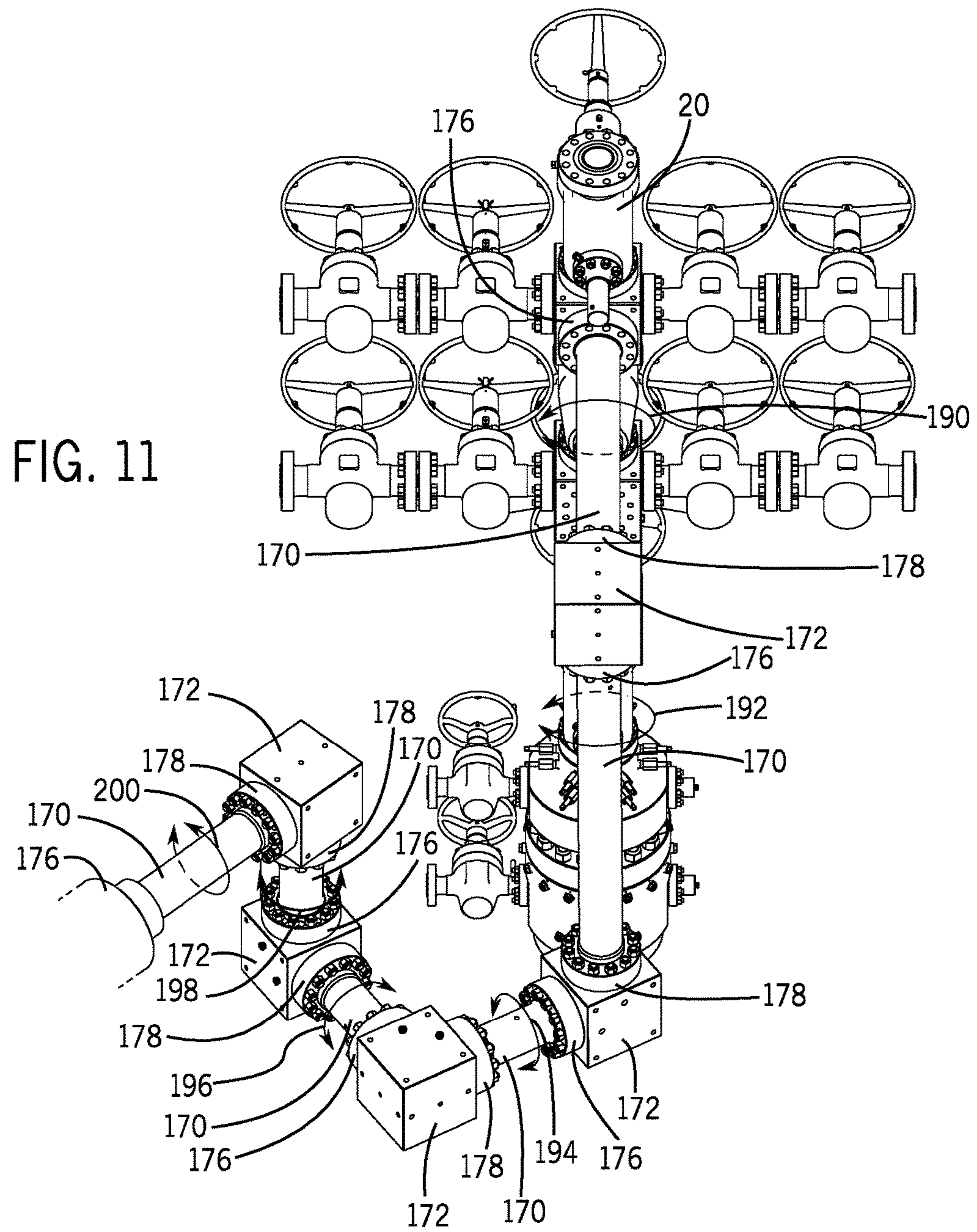
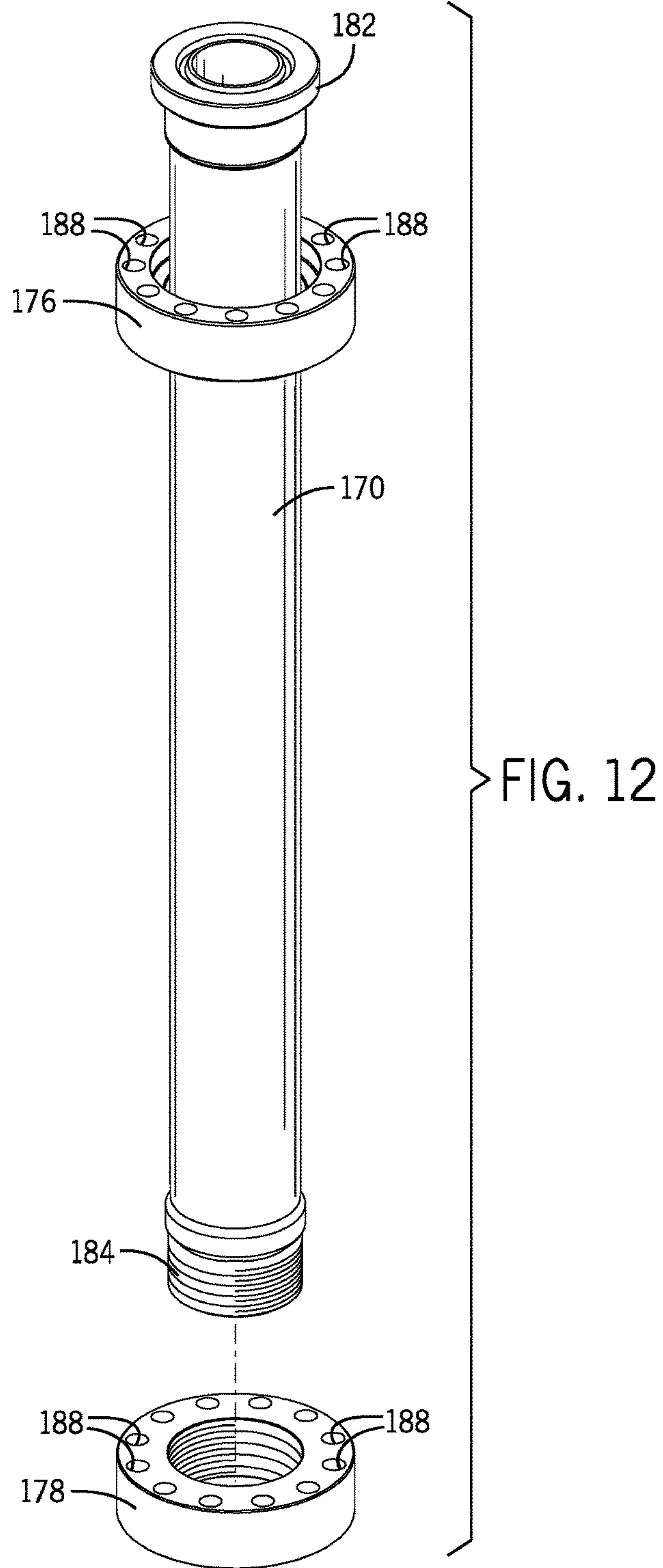

FIG. 10





1

FRACTURING MANIFOLD SYSTEMS AND METHODS

BACKGROUND

This section is intended to introduce the reader to various aspects of art that may be related to various aspects of the presently described embodiments. This discussion is believed to be helpful in providing the reader with background information to facilitate a better understanding of the various aspects of the present embodiments. Accordingly, it should be understood that these statements are to be read in this light, and not as admissions of prior art.

In order to meet consumer and industrial demand for natural resources, companies often invest significant amounts of time and money in searching for and extracting oil, natural gas, and other subterranean resources from the earth. Particularly, once a desired subterranean resource is discovered, drilling and production systems are often employed to access and extract the resource. These systems may be located onshore or offshore depending on the location of a desired resource. Further, such systems generally include a wellhead assembly through which the resource is extracted. These wellhead assemblies may include a wide variety of components, such as various casings, valves, fluid conduits, and the like, that control drilling or extraction operations.

Additionally, such wellhead assemblies may use a fracturing tree and other components to facilitate a fracturing process and enhance production from a well. As will be appreciated, resources such as oil and natural gas are generally extracted from fissures or other cavities formed in various subterranean rock formations or strata. To facilitate extraction of such resources, a well may be subjected to a fracturing process that creates one or more man-made fractures in a rock formation. This facilitates, for example, coupling of pre-existing fissures and cavities, allowing oil, gas, or the like to flow into the wellbore. Such fracturing processes typically include injecting a fracturing fluid—which is often a mixture including sand and water—into the well to increase the well's pressure and form the man-made fractures. A fracturing manifold may provide fracturing fluid to one or more fracturing trees via fracturing lines (e.g., pipes). But the fracturing manifolds and associated fracturing trees are typically large and heavy, and may be mounted to other equipment at a fixed location, making adjustments between the fracturing manifold and a fracturing tree difficult.

SUMMARY

Certain aspects of some embodiments disclosed herein are set forth below. It should be understood that these aspects are presented merely to provide the reader with a brief summary of certain forms the invention might take and that these aspects are not intended to limit the scope of the invention. Indeed, the invention may encompass a variety of aspects that may not be set forth below.

Embodiments of the present disclosure generally relate to fracturing systems having a fracturing manifold. In one embodiment, a fracturing system includes a fracturing manifold coupled to multiple fracturing trees via fluid conduits. Goat heads may be used to facilitate connection of the fracturing manifold to the fracturing trees. For example, one or more of the fracturing trees can be coupled to the fracturing manifold by a pair of goat heads in fluid communication with each other via at least one rigid fluid

2

conduit. In some instances, a fracturing manifold includes a trunk line for providing fracturing fluid to multiple outlet branches of the manifold. Further, the multiple outlet branches can include valves for controlling flow of fracturing fluid toward wells from the trunk line.

Various refinements of the features noted above may exist in relation to various aspects of the present embodiments. Further features may also be incorporated in these various aspects as well. These refinements and additional features may exist individually or in any combination. For instance, various features discussed below in relation to one or more of the illustrated embodiments may be incorporated into any of the above-described aspects of the present disclosure alone or in any combination. Again, the brief summary presented above is intended only to familiarize the reader with certain aspects and contexts of the some embodiments without limitation to the claimed subject matter.

BRIEF DESCRIPTION OF THE DRAWINGS

These and other features, aspects, and advantages of certain embodiments will become better understood when the following detailed description is read with reference to the accompanying drawings in which like characters represent like parts throughout the drawings, wherein:

FIG. 1 generally depicts an adjustable fracturing system in accordance with an embodiment of the present disclosure;

FIG. 2 is a diagram of the adjustable fracturing system of FIG. 1 with a fracturing manifold coupled to multiple fracturing trees in accordance with an embodiment of the present disclosure;

FIG. 3 is a perspective view of certain components of the adjustable fracturing system, including the fracturing manifold, one fracturing tree, and several adjustment joints in accordance with an embodiment of the present disclosure;

FIG. 4 is a perspective view of an adjustment joint in the form of a fracturing head in accordance with an embodiment of the present disclosure;

FIG. 5 is a cross-section of the fracturing head of FIG. 4 in accordance with an embodiment of the present disclosure;

FIG. 6 generally depicts the fracturing head of FIGS. 4 and 5 following adjustment of the fracturing head to increase its length in accordance with an embodiment of the present disclosure;

FIG. 7 is a perspective view of an adjustment joint in the form of a fracturing head having inlet and outlet ports that are not axially aligned with each other in accordance with an embodiment of the present disclosure;

FIG. 8 is a partial cross-section of a fracturing head including a test port to enable integrity testing between two seals of the fracturing head in accordance with an embodiment of the present disclosure;

FIG. 9 is a cross-section of an adjustment joint in the form of a pipe connector having a length that may be varied in accordance with an embodiment of the present disclosure;

FIG. 10 is a perspective view of certain components of an adjustable fracturing system, including fluid conduits having multiple pipes connected between the fracturing manifold and two fracturing trees, in accordance with an embodiment of the present disclosure;

FIG. 11 is a detail view of one of the fluid conduits of FIG. 10; and

FIG. 12 generally depicts one pipe of the fluid conduit of FIG. 11 as having a swivel connection on one end that allows

rotation of the pipe with respect to another portion of the fluid conduit in accordance with one embodiment.

DETAILED DESCRIPTION OF SPECIFIC EMBODIMENTS

One or more specific embodiments of the present disclosure will be described below. In an effort to provide a concise description of these embodiments, all features of an actual implementation may not be described in the specification. It should be appreciated that in the development of any such actual implementation, as in any engineering or design project, numerous implementation-specific decisions must be made to achieve the developers' specific goals, such as compliance with system-related and business-related constraints, which may vary from one implementation to another. Moreover, it should be appreciated that such a development effort might be complex and time consuming, but would nevertheless be a routine undertaking of design, fabrication, and manufacture for those of ordinary skill having the benefit of this disclosure.

When introducing elements of various embodiments, the articles "a," "an," "the," and "said" are intended to mean that there are one or more of the elements. The terms "comprising," "including," and "having" are intended to be inclusive and mean that there may be additional elements other than the listed elements. Moreover, any use of "top," "bottom," "above," "below," other directional terms, and variations of these terms is made for convenience, but does not require any particular orientation of the components.

Turning now to the present figures, an example of a fracturing system 10 is provided in FIGS. 1 and 2 in accordance with one embodiment. The fracturing system 10 facilitates extraction of natural resources (e.g., oil or natural gas) from a well 12 via a wellbore 14 and a wellhead 16. Particularly, by injecting a fracturing fluid into the well 12, the fracturing system 10 increases the number or size of fractures in a rock formation or strata to enhance recovery of natural resources present in the formation. In the presently illustrated embodiment, the well 12 is a surface well accessed by equipment of wellhead 16 installed at surface level (i.e., on ground 18). But it will be appreciated that natural resources may be extracted from other wells, such as platform or subsea wells.

The fracturing system 10 includes various components to control flow of a fracturing fluid into the well 12. For instance, the depicted fracturing system 10 includes a fracturing tree 20 and a fracturing manifold 22. The fracturing tree 20 includes at least one valve that controls flow of the fracturing fluid into the wellhead 16 and, subsequently, into the well 12. Similarly, the fracturing manifold 22 includes at least one valve that controls flow of the fracturing fluid to the fracturing tree 20 by a conduit or fluid connection 26 (e.g., pipes).

The fracturing manifold 22 is mounted on at least one skid 24 (e.g., a platform mounted on rails) to enable movement of the fracturing manifold 22 with respect to the ground 18. As depicted in FIG. 2, the fracturing manifold 22 is connected to provide fracturing fluid to multiple fracturing trees 20 and wellheads 16. But it is noted that the fracturing manifold 22 may instead be coupled to a single fracturing tree 20 in full accordance with the present techniques. In one embodiment in which the fracturing manifold 22 is coupled to multiple fracturing trees 20, various valves of the fracturing manifold 22 may be mounted on separate skids 24 to enable variation in the spacing between the valves. And in at least some instances, as described in further detail below,

such a configuration allows for easier alignment of the fluid connection 26 between the fracturing manifold 22 and the fracturing tree 20.

Fracturing fluid from a supply 28 is provided to the fracturing manifold 22. In FIG. 1, a connector 30 receives fracturing fluid from the supply 28 through a conduit or fluid connection 32 (e.g., pipes or hoses) and then transmits the fluid to the fracturing manifold 22 by way of a subterranean conduit or fluid connection 34 (e.g., pipes). In one embodiment, the fracturing fluid supply 28 is provided by one or more trucks that deliver the fracturing fluid, connect to the connector 30, and pump the fluid into the fracturing manifold 22 via the connector 30 and connections 32 and 34. In another embodiment, the fracturing fluid supply 28 is in the form of a reservoir from which fluid may be pumped into the fracturing manifold 22. But any other suitable sources of fracturing fluid and manners for transmitting such fluid to the fracturing manifold may instead be used.

A portion 40 of the fracturing system 10 is illustrated in FIG. 3 in accordance with one embodiment. In the depicted embodiment, the portion 40 includes the fracturing tree 20 and the fracturing manifold 22, as well as several adjustment joints that enable alignment of the connection line (i.e., fluid connection 26) between the fracturing tree 20 and the fracturing manifold 22. The manifold 22 includes a conduit 42 that routes fracturing fluid to valves 44 and 46. These valves 44 and 46 are coupled to connecting blocks 48 and 50 of the conduit 42 to receive fracturing fluid from the fluid supply 28 via connections 32 and 24. The fracturing fluid may then be routed through fluid connection 26 to a respective fracturing tree 20. Although the present embodiment includes two valves 44 and two valves 46, any other suitable number of valves may instead be used to control flow of fracturing fluid to fracturing trees 20. Further, while the depicted fluid connection 26 includes a single flow path or conduit (which may be a fracturing line with a seven-inch bore in one instance) between the fracturing tree 20 and the fracturing manifold 22, a fracturing system may include a greater number of conduits between the fracturing manifold and a fracturing tree in other embodiments.

The fracturing tree 20 is provided in the form of a horizontal fracturing tree in FIG. 3, though other embodiments may include a different style of fracturing tree (e.g., a vertical tree). The depicted fracturing tree 20 includes valves 52 to control flow of fracturing fluid through a horizontal portion of the tree 20. The tree 20 also includes a master valve 54 to control flow of fluids (e.g., fracturing fluids or production fluids) to or from the attached wellhead 16 (FIG. 1), and a port 56 allowing access to the wellhead 16 through the master valve 54. In other embodiments, the valve 54 may be omitted (e.g., in a composite tree arrangement with all valves integral to one block).

The portion 40 of the fracturing system 10 also includes extendable adjustment joints that facilitate connection of the fracturing manifold 22 to the fracturing tree 20. In the presently illustrated embodiment, the adjustment joints are provided in the form of adjustable fracturing heads 60, 62, and 64 (also commonly referred to as "goat heads"), though other forms of adjustment joints are also envisaged and may be used in accordance with the present techniques. In operation, the fracturing tree 20 may be mounted at a fixed location (i.e., coupled to the wellhead 16). The fluid connection 26 is aligned and coupled between the fracturing tree 20 and the fracturing manifold 22. The adjustment joints (e.g., the fracturing heads 60, 62, and 64 in FIG. 3) facilitate such alignment and coupling of the fluid connection by allowing an operator to manipulate the position of the fluid

5

connection 26 by changing a dimension (e.g., length or height) of the adjustment joint. By providing three adjustment joints, each with a different axis of movement (i.e., up-and-down, forward-and-backward, and left-and-right), adjustments can be made to help facilitate coupling of the fracturing manifold 22 to the fracturing tree 20.

For example, the conduit 42 includes a fracturing head 60 that may be extended or retracted (as represented by arrow 68) to vary the length of the conduit 42 and the distance between the valves 44 and 46 (which may be mounted on separate skids 24, as discussed above, to allow relative motion between the valves 44 and 46). Such variation also provides a first degree of freedom in aligning the fluid connection 26 between the fracturing tree 20 and the fracturing manifold 22. In other words, the adjustment joint in conduit 42 allows the distance between the seal points of the fluid connection 26 at the fracturing tree 20 and at the fracturing manifold 22 to be varied in a first dimension.

Likewise, the fluid connection 26 in FIG. 3 includes the fracturing head 62 to vary the length of the fluid connection 26 in a second dimension, as represented by arrow 70. The adjustability of the fracturing head 62 provides a second degree of freedom in aligning the connection between the fracturing tree 20 and the fracturing manifold 22. Further, the portion 40 includes the fracturing head 64 having a variable length in a third dimension (as represented by arrow 72), thus providing a third degree of freedom in aligning the fluid connection 26 between the fracturing tree 20 and the fracturing manifold 22. These three degrees of freedom are provided by three adjustment joints having different directions of adjustment that are not parallel, and in some embodiments (such as in FIG. 3) the directions of adjustment are orthogonal to one another. In addition to these three translational degrees of freedom, one or more of the adjustment joints (e.g., fracturing heads 60, 62, and 64) may also be rotated about their axes, as indicated by arrows 69, 71, and 73, to provide rotational degrees of freedom. For example, the presently depicted embodiment provides six degrees of freedom (three translational and three rotational).

While large fracturing lines (e.g., with a seven-inch bore) are traditionally difficult to adjust between a fracturing manifold and a fracturing tree, the adjustability provided in the presently disclosed system 10 enables large fracturing lines to be aligned and connected to such components more efficiently. Consequently, as depicted in FIG. 3, a single fluid connection 26 may be provided in the form of a large-bore fracturing line, rather than using multiple smaller-bore fracturing lines between the fracturing manifold and a given fracturing tree.

While the presently depicted embodiment includes three adjustment joints, it is noted that other embodiments may include fewer adjustment joints providing fewer degrees of freedom in aligning the fluid connection 26. For instance, a single adjustment joint may be provided to give one translational degree of freedom (e.g., up-and-down, forward-and-backward, or left-and-right) in aligning the fracturing tree 20 and the fracturing manifold 22 for the fluid connection 26. Or two adjustment joints may be provided to give two translational degrees of freedom. Such adjustment joints may also provide rotational degrees of freedom as noted above. Further still, multiple adjustment joints may be aligned coaxially to provide adjustability at different locations within the system 10 (e.g., the manifold 22 may include multiple, coaxial adjustment joints).

For clarity, only a single fluid connection 26 and a single fracturing tree 20 (both of which receive fracturing fluid from the valves 44) are depicted in FIG. 3 as part of portion

6

40 of the fracturing system 10. But it will be appreciated that the fracturing system 10 may include additional fluid connections 26 and fracturing trees 20 (see, e.g., FIG. 2). For example, valves 46 may be coupled (e.g., via outlet 74) to another fluid connection 26 leading to a different fracturing tree 20 on another wellhead 16. Further, the conduit 42 may extend beyond the depicted connection blocks 48 and 50 to route fracturing fluid to additional valves and associated fracturing trees 20. And the conduit 42 may include additional adjustment joints to enable movement of such additional valves relative to another portion of the manifold 22, thereby facilitating alignment of these valves with their associated fracturing trees 20.

The fracturing head 60, in accordance with one embodiment, is illustrated in greater detail in FIGS. 4-6. In the depicted embodiment, the fracturing head 60 includes a body having a first portion 82 and a second portion 84. The body portions 82 and 84 are configured to move with respect to one another to vary a dimension of the fracturing head and facilitate connection of the fracturing manifold 22 and the fracturing tree 20 as described above. The fracturing head 60 includes fluid ports 86 and 114 (FIG. 5) to transmit fluid through the fracturing head 60. In some embodiments, such as when installed in the fracturing system 10 in the manner depicted in FIG. 3, the fluid port 86 may be considered an output port and the fluid port 114 may be considered an inlet port. In addition to the fluid port 86, the second body portion 84 includes a set of studs 88 and nuts 90 for connecting the fracturing head 60 to another component (e.g., via an API flange or other connector). Similarly, the first body portion 82 includes through holes 92 arranged in a flange 93 about the fluid port 114 for coupling to another component (e.g., also coupled to an API flange via additional studs and nuts or to another connector). The first body portion 82 includes an additional set of through holes 95 positioned radially outward from the through holes 92. The through holes 95 are aligned with mating holes 97 in a flange 99 of the second body portion 84, and the first and second body portions 82 and 84 are secured to one another with studs 94 (through the holes 95 and 97) and nuts 96.

As depicted in FIGS. 5 and 6, a bore 98 extends through the fracturing head 60 between the fluid ports 86 and 114. The bore 98 may have a diameter similar or identical to that of the components coupled to the fluid ports 86 and 114, such as seven inches in one embodiment (though other diameters may be used for the bore 98, as well as for other components). The bore may also be sized to match the inner diameter of the production casing in the well (i.e., a full bore arrangement) to facilitate the passage of tools, plugs, or the like through the fracturing head 60. The fracturing head 60 includes an adjustment collar 100 that may be rotated on threads 104 by a user to translate the collar 100 with respect to the body portion 82 or 84 of the fracturing head 60 on which the collar is threaded (i.e., first body portion 82 in FIGS. 5 and 6). Movement of the adjustment collar 100 allows adjustment of the length of the fracturing head 60 and the distance between fluid ports 86 and 114. Particularly, as illustrated in FIG. 6, nuts 96 may be loosened on the studs 94 and the adjustable collar 100 may be moved along the first body portion 82 to lengthen the fracturing head 60. In this manner, the length (or what may instead be considered the height) of the fracturing head 60 may be varied to aid in aligning and coupling the fracturing manifold 22 and the fracturing tree 20 via the fluid connection 26, as discussed above. The fracturing head 60, as well as other adjustment joints in the system 10 (e.g., the fracturing heads 62 and 64 or the pipe connector 130 of FIG. 9), may be constructed to

allow for any desired amount of variation in dimension. For instance, the adjustment joints may be constructed to allow dimensional variation (e.g., lengthening) of seven inches in one embodiment, of twelve inches in another embodiment, and of eighteen inches in still another embodiment. Still further, it is noted that in addition to the translational and rotational degrees of freedom facilitated through use of the presently disclosed adjustment joints, angular adjustment between elements of the fracturing system **10** can be enabled through the inclusion of pivot joints or other suitable couplings.

The fracturing head **60** also includes various sealing elements to inhibit fluid leakage. For instance, as depicted, fracturing head **60** includes sealing elements **102**, **106**, **108**, **110**, and **112**. The sealing elements are formed of any suitable material, such as an elastomer or metal. In one embodiment, the seals **110** include CANH™ seals available from Cameron International Corporation of Houston, Tex. Also, in one embodiment movement of the collar **100** pre-loads or energizes one or more of the seals of the fracturing head **60**.

As depicted in FIG. 7, the fracturing head **64** is generally similar to the fracturing head **60** (and the fracturing head **62**, which is identical to the fracturing head **60** in one embodiment) but includes a fluid port **86** on a side face of the body portion **84** rather than on the top face. As illustrated in FIG. 3, such an arrangement enables the fracturing head **64** to connect a pipe of fluid connection **26** with the fracturing tree **20** via a bore bent at an angle (e.g., at a right angle) to change the direction of fluid flowing through the fracturing head **64**. And a dimension of the fracturing head **64** may be varied in the same manner as described above with respect to fracturing head **60**, thereby facilitating alignment and coupling of the fracturing tree **20** and the fracturing manifold **22** with the fluid connection **26**.

In one embodiment illustrated in FIG. 8, a fracturing head (e.g., fracturing head **60**, **62**, or **64**) includes seals **118** and **120** (rather than sealing elements **106**, **108**, and **110**) disposed in an annular space **122**. The seals **118** and **120** are formed of any suitable material, and may include metal CANH™ seals in one embodiment. The annular space **122** is bound by the body portion **82**, the body portion **84**, and the adjustable collar **100**. A test port **124** extends from the annular space **122** (e.g., at a location between the seals **118** and **120**) to an exterior surface of the body portion **84** to allow connection of a pressure monitoring device to enable monitoring or testing of the integrity of the seals **118** and **120**.

While the adjustment joints of the fracturing system **10** have been described above in the form as fracturing heads, other embodiments may use other adjustment joints in addition to, or in place of, the fracturing heads. For example, one or more of the fracturing heads **60**, **62**, and **64** of FIG. 3 may be replaced by other adjustment joints in additional embodiments. One example of another adjustment joint is depicted in FIG. 9 in the form of a pipe connector **130**. The connector **130** includes a first tubular member **132** and a second tubular member **134**. The tubular members **132** and **134** may be pipes (e.g., of the fluid connection **26** or conduit **42**), or they may be coupled to pipes or other conduits in any suitable fashion. The opposite ends of the connector include an inlet and an outlet, allowing fracturing fluid to flow through the connector **130** via the bores of either the members **132** and **134** themselves or of the pipes or other conduits joined by the connector **130**.

The connector **130** is configured to enable relative movement between the tubular members **132** and **134** to allow

variation in the length of the connector **130**. Like the fracturing heads **60**, **62**, and **64**, the connector **130** may be constructed to allow any desired range of variation in length, such as a range of seven inches or twelve inches. Various seals **136**, **138**, and **140** are provided between the tubular members **132** and **134**. In one embodiment, the seal **136** is an elastomeric seal and the seals **138** and **140** are metal CANH™ seals.

The connector **130** also includes a collar **142** (which may also be referred to herein as union nut **142**) that cooperates with a flanged collar **154** to adjust the length of the connector **130**. The union nut **142** may be coupled to the first tubular member **132** in any suitable manner. In the depicted embodiment, threads **146** allow the union nut **142** to be threaded onto the tubular member **132**. The union nut **142** includes an end **150** that engages the collar **154** via threads **152**, and rotation of the union nut **142** causes the collar **154** to move along the axis of the connector **130** with respect to the tubular member **132**. A flange **156** of the collar **154** is coupled to a mating flange **158** of the tubular member **134** by studs **160** and nuts **162**. Consequently, rotation of the union nut **142** also causes the second tubular member **134** to be moved with respect to the first tubular member **132**, thereby enabling the connector **130** to be lengthened or shortened through such operation. The connector **130** may also include a test port **164** to enable monitoring of the integrity of seals **138** and **140** in a manner similar to that described above with respect to test port **124** (FIG. 8).

Another embodiment in which fluid conduits **26** are adjustable to facilitate coupling of the fluid conduits **26** between the fracturing manifold **22** and fracturing trees **20** is generally depicted in FIG. 10. In this embodiment, the adjustment joints for the fracturing system are provided in the form of rotatable pipe joints **170** and connection blocks **172** (e.g., elbow blocks) of the fluid conduits **26**. The ability to rotate components of the fluid conduits **26** provides rotational degrees of freedom similar to those described above, and enables the fluid conduits **26** to be more easily positioned and connected between the fracturing manifold **22** and the fracturing trees **20**. As presently illustrated, the fluid conduits **26** with rotatable components have three rotational degrees of freedom, although other embodiments could have fewer than three. In some instances, the adjacent pipes **170** and connection blocks **172** could be rotated to desired positions before assembling these components together (e.g., via a studded connection). But in at least some embodiments, the fluid conduit **26** includes a swivel connection that enables rotation of one portion of the fluid conduit **26** with respect to another portion of the fluid conduit **26** while those portions are connected to one another.

One example of such an arrangement is depicted in FIG. 11. In this embodiment, the fluid conduit **26** includes a number of swivel connections (having swivel rings **176**) that allow pipes **170** and connection blocks **172** to rotate with respect to one another. Each pipe **170** is depicted in FIG. 11 as having a swivel connection (with a swivel ring **176**) at one end and a fixed, non-swivel connection (with a threaded flange **178**) at its other end, although fewer pipes **170** could have swivel connections in other embodiments.

An example of a pipe **170** having such connections is depicted in greater detail in FIG. 12 in accordance with one embodiment. In this example, the pipe **170** includes a flange **182** at one end and a threaded surface **184** at its other end. When the pipe **170** is assembled in the fluid conduit **26**, the flange **182** is received within the swivel ring **176**. This allows the flange **182** (along with the pipe **170**) to rotate with

respect to the swivel ring 176 and to the component to which the swivel ring 176 is attached (e.g., a connection block 172, the fracturing manifold 22, or a fracturing tree 20). The threaded flange 178 can be connected to the threaded surface 184 to allow that end of the pipe 170 to also be connected to another component of the fluid conduit 26. As depicted, the swivel ring 176 and the threaded flange 178 include through holes 188 to allow them to be connected to other components via studded connections. But other kinds of connections could also be used in accordance with the present technique.

Returning now to FIG. 11, it can be seen that the swivel connections enable the rotation of the pipes 170 and the connection blocks 172, as generally represented by arrows 190, 192, 194, 196, 198, and 200. The swivel connection at one end of a pipe 170 allows the pipe 170 to be rotated about its axis to change the orientation of the connection block 172 (which rotates with the pipe 170) coupled to the pipe 170 at the fixed connection opposite the swivel. And through the rotation of these components, overall dimensions of the fluid conduit 26 can be changed to accommodate variances in distances and elevations between the fracturing manifold 22 and the fracturing trees 20. That is, by rotating the various components of the fluid conduit 26, the pipes 170 may be extended and retracted to position the fluid conduit 26 appropriately for coupling between the fracturing manifold 22 and a fracturing tree 20.

Like some other embodiments described above, the fracturing system depicted in FIG. 11 uses only a single fluid conduit 26 per fracturing tree 20 rather than using multiple, smaller fluid conduits. In one embodiment, the bore of the fluid conduit is seven and one-sixteenth inches at the end of the conduit 26 that receives fracturing fluid from the manifold 22 and is five and one-eighth inches at the end of the conduit 26 connected to the fracturing tree. But it will be appreciated that conduits 26 may have different dimensions in other embodiments. Additionally, although the pipes 170 are shown connected orthogonally to one another via the connection blocks 172 in the present embodiment, other embodiments could include pipes 170 connected to one another at different angles.

While the aspects of the present disclosure may be susceptible to various modifications and alternative forms, specific embodiments have been shown by way of example in the drawings and have been described in detail herein. But it should be understood that the invention is not intended to be limited to the particular forms disclosed. Rather, the invention is to cover all modifications, equivalents, and alternatives falling within the spirit and scope of the invention as defined by the following appended claims.

The invention claimed is:

1. A system comprising:

a fracturing manifold;

a plurality of fracturing trees;

a plurality of fluid conduits coupled between the fracturing manifold and the plurality of fracturing trees to enable receipt of fracturing fluid by the plurality of fracturing trees from the fracturing manifold;

a first goat head; and

a second goat head;

wherein a fracturing tree of the plurality of fracturing trees is coupled to the fracturing manifold via the first goat head, the second goat head, and at least one rigid fluid conduit of the plurality of fluid conduits, wherein the first goat head and the second goat head are in fluid communication with each other via the at least one rigid fluid conduit, and wherein the second goathead is

connected to receive fracturing fluid from the first goathead via the at least one rigid fluid conduit and to provide the received fracturing fluid to the fracturing tree from the second goat head through one and only one fluid pathway extending laterally from the fracturing tree.

2. The system of claim 1, wherein the fracturing manifold includes:

a shared trunk conduit for routing fracturing fluid to multiple fracturing trees of the plurality of fracturing trees; and

outlet branches for routing fracturing fluid from the shared trunk conduit to individual fracturing trees of the multiple fracturing trees.

3. The system of claim 2, wherein the outlet branches of the fracturing manifold include valves to individually control flow of fracturing fluid from the shared trunk conduit to the multiple fracturing trees.

4. The system of claim 3, wherein the outlet branches of the fracturing manifold include:

a first outlet branch having two valves connected in series to control flow of fracturing fluid to a first fracturing tree of the multiple fracturing trees; and

a second outlet branch having two valves connected in series to control flow of fracturing fluid to a second fracturing tree of the multiple fracturing trees.

5. The system of claim 4, wherein the first outlet branch of the fracturing manifold includes the first goat head attached in series with the two valves of the first outlet branch such that, in operation, fracturing fluid can be routed from the shared trunk conduit through the two valves of the first outlet branch to the first goat head.

6. The system of claim 5, wherein the first goat head includes a single outlet.

7. The system of claim 1, wherein the at least one rigid fluid conduit includes a plurality of pipe joints coupled to one another.

8. The system of claim 7, wherein the at least one rigid fluid conduit includes an elbow.

9. The system of claim 1, wherein the at least one rigid fluid conduit is an adjustable fluid conduit that allows an operator to vary a dimension of the fluid conduit to facilitate coupling of the fluid conduit between the fracturing manifold and the fracturing tree.

10. The system of claim 1, wherein the at least one rigid fluid conduit includes an adjustment joint that provides at least one translational degree of freedom in aligning the at least one rigid fluid conduit between the fracturing manifold and the fracturing tree.

11. The system of claim 1, wherein the second goat head is attached to the fracturing tree.

12. A method comprising:

assembling a fracturing manifold having a trunk line for distributing fracturing fluid to multiple wells through multiple outlets of the fracturing manifold;

connecting the fracturing manifold to the multiple wells via rigid conduits, wherein connecting the fracturing manifold to the multiple wells via rigid conduits includes connecting the fracturing manifold to one of the multiple wells via at least one of the rigid conduits extending from an upstream goat head positioned to receive fracturing fluid from the fracturing manifold to a downstream goat head positioned to receive fracturing fluid from the upstream goat head via the at least one of the rigid conduits, and wherein connecting the fracturing manifold to the multiple wells via rigid conduits also includes connecting the fracturing mani-

fold to the one of the multiple wells via at least one additional rigid conduit that connects the downstream goahead to a fracturing tree of the one of the multiple wells and that includes a pipe that extends laterally from the fracturing tree;

5

routing fracturing fluid from the fracturing manifold to the multiple wells through the rigid conduits, wherein routing fracturing fluid from the fracturing manifold to the multiple wells through the rigid conduits includes routing fracturing fluid to the one of the multiple wells such that the one of the multiple wells receives only fracturing fluid conveyed through the pipe that extends laterally from the fracturing tree.

10

13. The method of claim **12**, wherein assembling the fracturing manifold includes assembling the fracturing manifold so as to include outlet branches having valves for controlling flow of fracturing fluid from the trunk line to the multiple outlets, and routing fracturing fluid from the fracturing manifold to the multiple wells through the rigid conduits includes operating the valves of the outlet branches to control flow of fracturing fluid to the multiple wells through the rigid conduits.

15

20

14. The method of claim **13**, wherein assembling the fracturing manifold so as to include outlet branches having valves for controlling flow of fracturing fluid from the trunk line to the multiple outlets includes providing at least one outlet branch that is in fluid communication with the trunk line and that includes: a first valve coupled to the trunk line, a second valve connected downstream of the first valve, and the upstream goat head connected downstream of the second valve.

25

30

* * * * *