



US010385523B2

(12) **United States Patent**  
**Bjorge et al.**

(10) **Patent No.:** **US 10,385,523 B2**  
(45) **Date of Patent:** **Aug. 20, 2019**

(54) **MOLDBOARD RETENTION SYSTEM FOR A MILLING MACHINE**

(71) Applicant: **Caterpillar Paving Products Inc.**,  
Brooklyn Park, MN (US)

(72) Inventors: **Jason Bjorge**, Blaine, MN (US);  
**Nathan Mashek**, Saint Michael, MN (US)

(73) Assignee: **Caterpillar Paving Products Inc.**,  
Brooklyn Park, MN (US)

(\*) Notice: Subject to any disclaimer, the term of this patent is extended or adjusted under 35 U.S.C. 154(b) by 0 days.

(21) Appl. No.: **15/849,033**

(22) Filed: **Dec. 20, 2017**

(65) **Prior Publication Data**

US 2019/0186088 A1 Jun. 20, 2019

(51) **Int. Cl.**  
**E01C 23/08** (2006.01)  
**E01C 23/12** (2006.01)  
**E01C 23/088** (2006.01)

(52) **U.S. Cl.**  
CPC ..... **E01C 23/088** (2013.01); **E01C 23/127** (2013.01)

(58) **Field of Classification Search**  
CPC ..... E01C 23/088; E01C 23/127  
See application file for complete search history.

(56) **References Cited**

U.S. PATENT DOCUMENTS

5,474,397 A 12/1995 Lyons  
9,127,417 B2 9/2015 Risi

9,416,502 B2 \* 8/2016 Emme ..... E01C 23/088  
2009/0010713 A1 \* 1/2009 Kotting ..... E01C 19/004  
404/128  
2009/0044366 A1 \* 2/2009 Kotting ..... E01C 23/088  
15/256.51  
2013/0154340 A1 6/2013 Kotting et al.  
2013/0195554 A1 \* 8/2013 Rukavina ..... E01C 23/088  
404/90  
2013/0249271 A1 \* 9/2013 Killion ..... E01C 23/088  
299/1.5  
2014/0361599 A1 \* 12/2014 Losen ..... E01C 23/088  
299/39.2  
2016/0040371 A1 \* 2/2016 Roetsch ..... E01C 23/088  
299/39.4  
2018/0163351 A1 6/2018 Frankemolle et al.

FOREIGN PATENT DOCUMENTS

CN 202881834 U 4/2013

\* cited by examiner

*Primary Examiner* — Abigail A Risi

(74) *Attorney, Agent, or Firm* — Brookoff McAndrews

(57) **ABSTRACT**

A milling machine includes a frame, a ground-engaging rotor assembly coupled to the frame, and a rotor chamber surrounding the ground-engaging rotor assembly. The rotor chamber includes a moldboard having a top, a bottom, and two sides positioned between the top and the bottom, and the moldboard further having an open position and a closed position. The rotor chamber also includes at least one movable pin secured to the moldboard, the pin being movable by an in-line actuator between a pin extended position and a pin retracted position. Further, the rotor chamber includes a rotor chamber frame wall having an opening located to receive the pin when the pin is in the extended position and the moldboard is in the closed position, and the receiving of the pin in the rotor chamber frame wall opening secures the moldboard from movement.

**19 Claims, 7 Drawing Sheets**

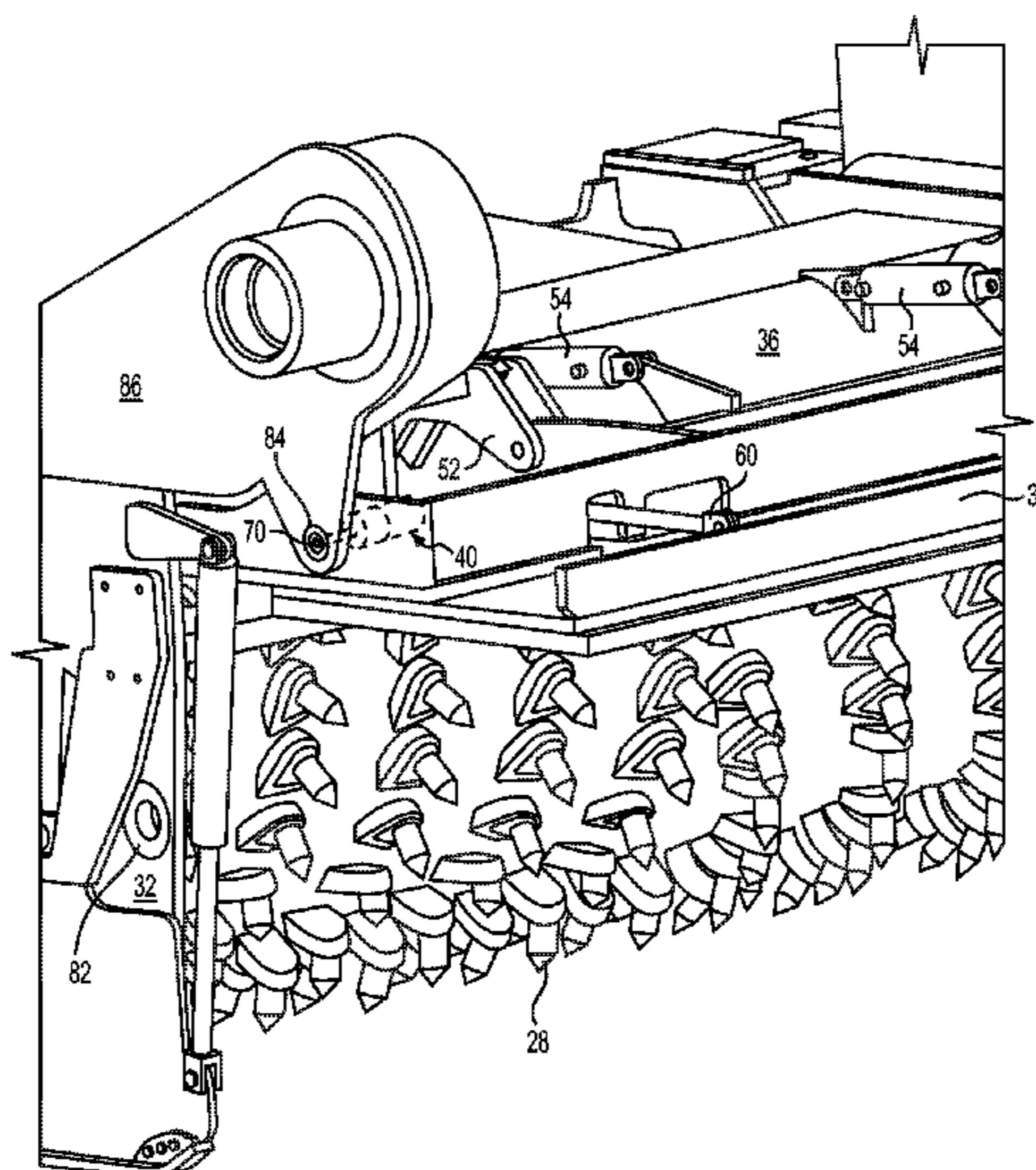

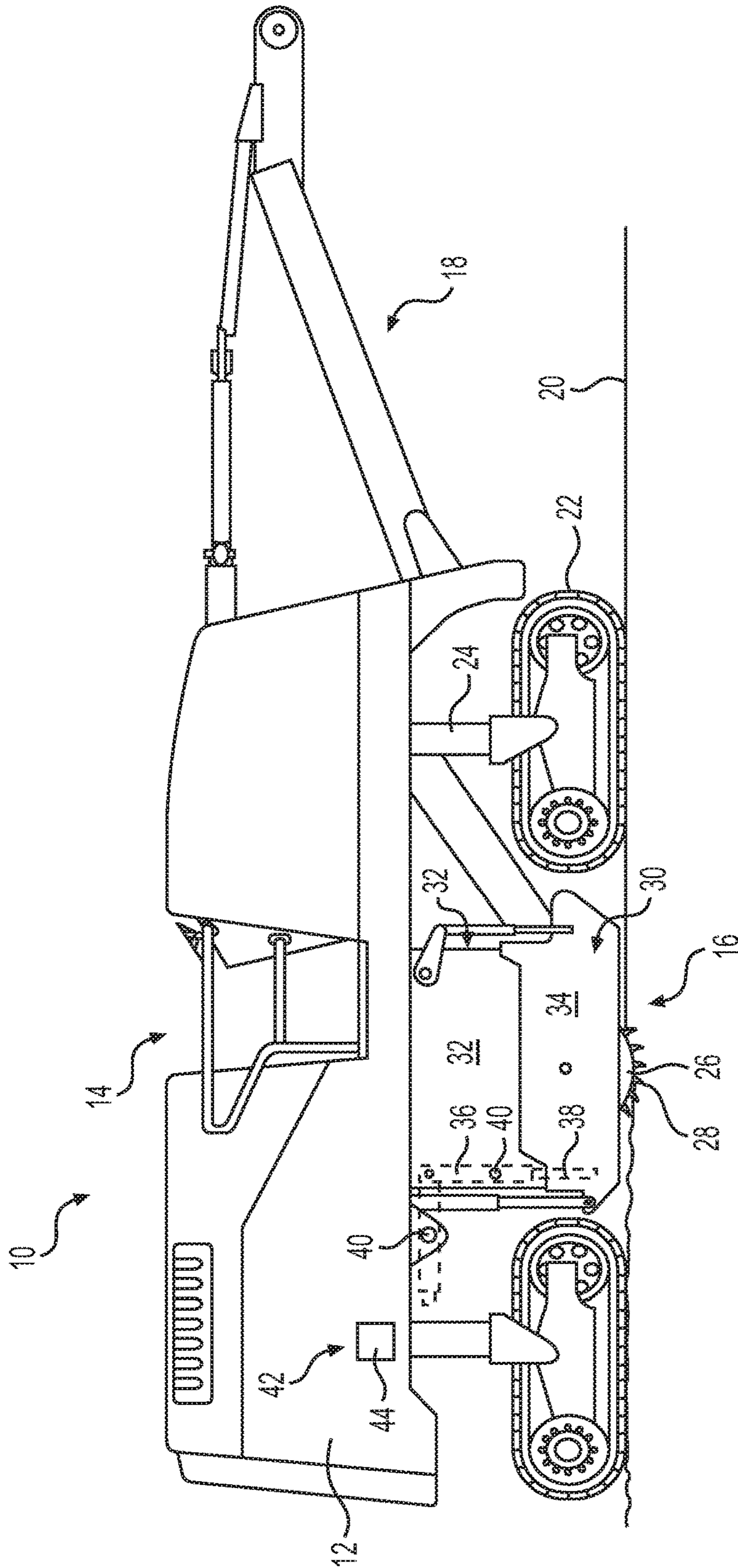

FIG. 1

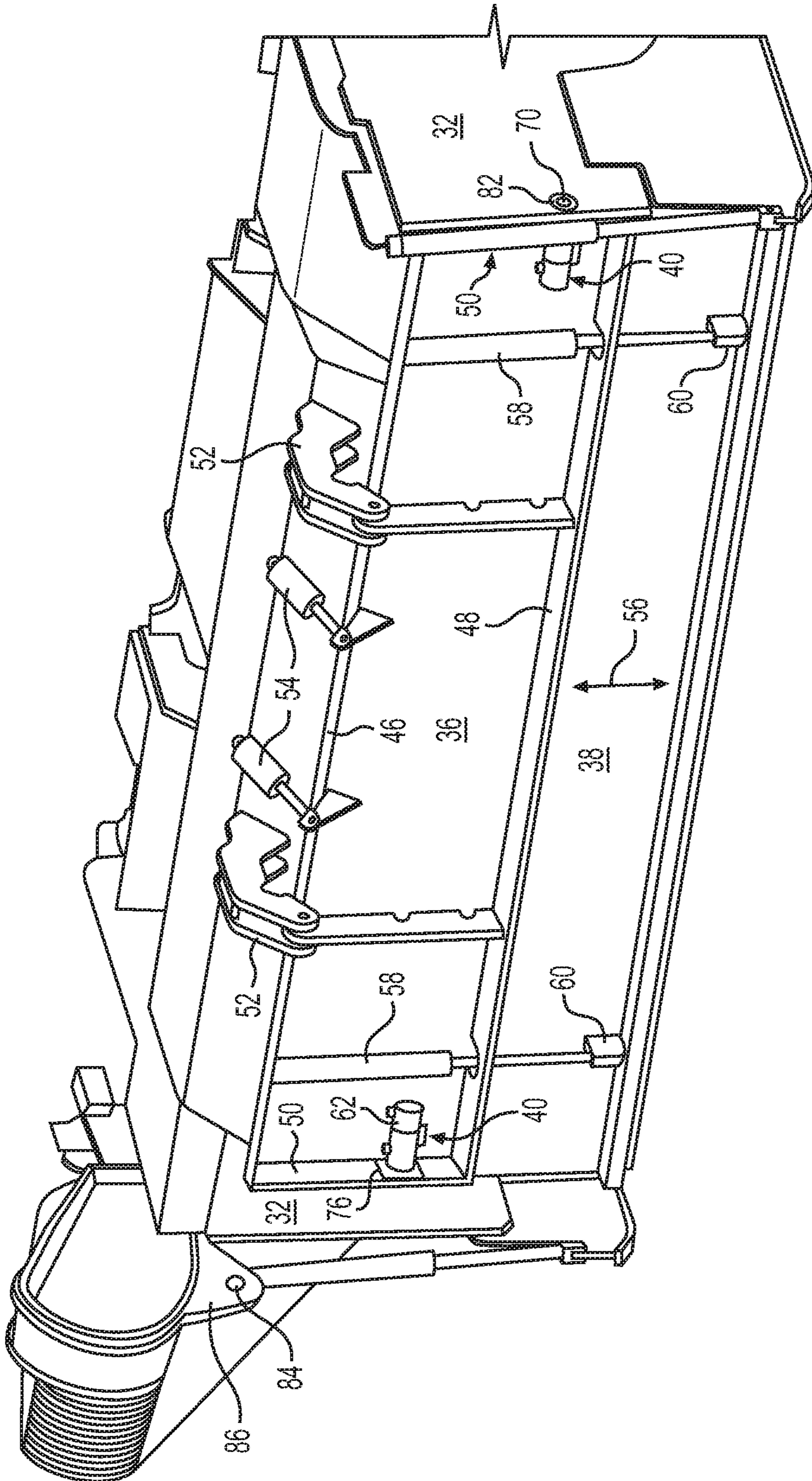
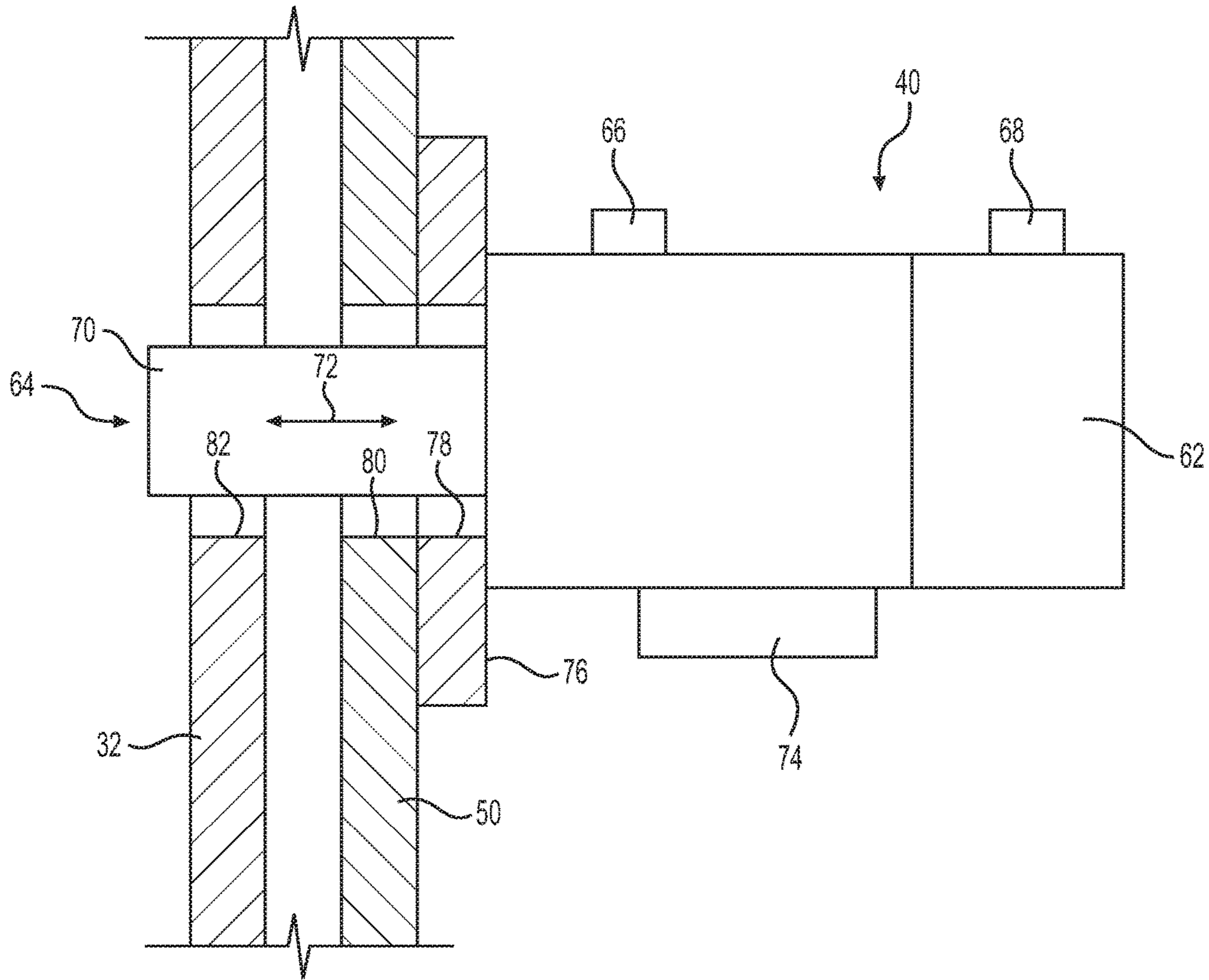
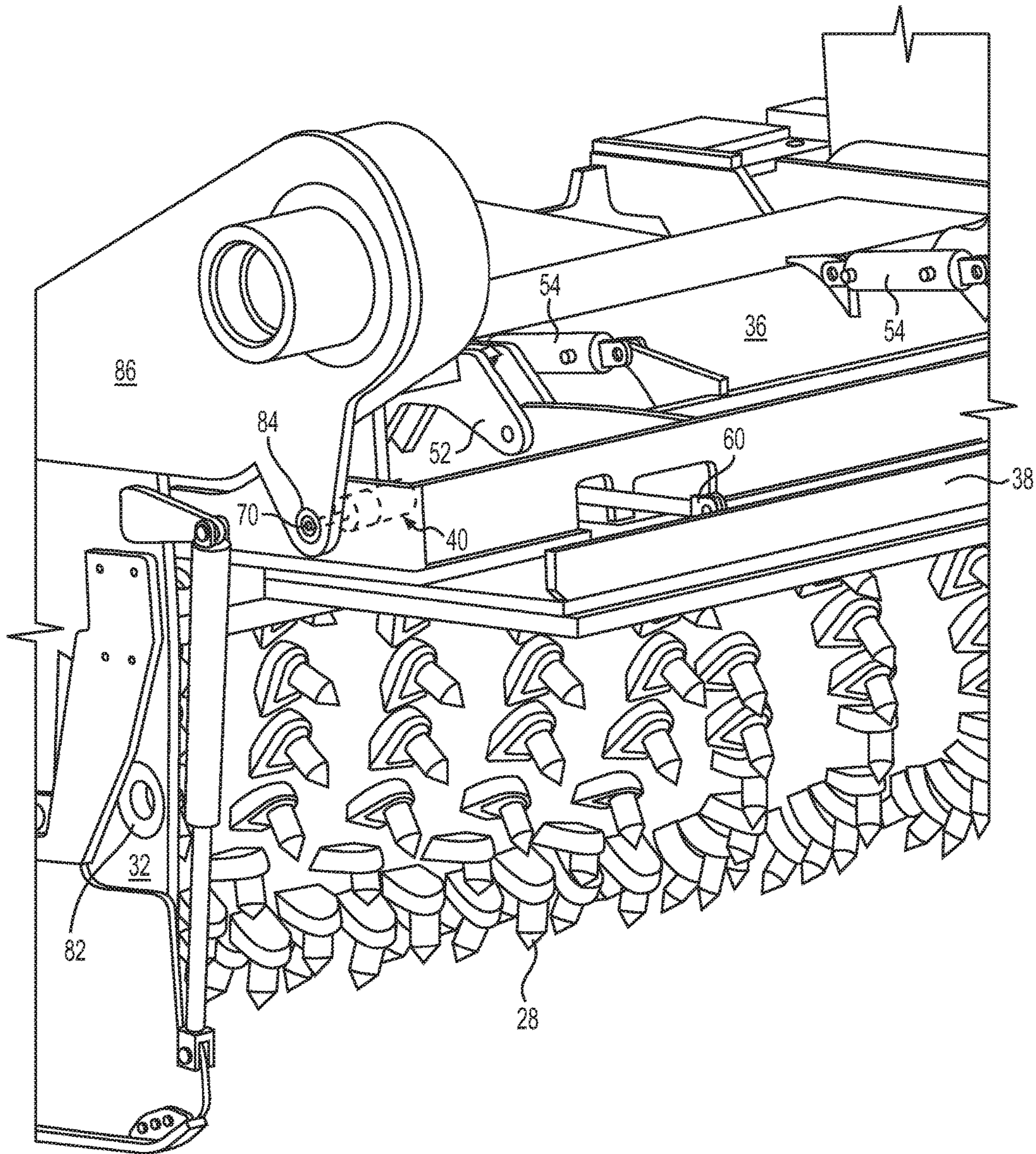

FIG. 2



**FIG. 3**



**FIG. 4**

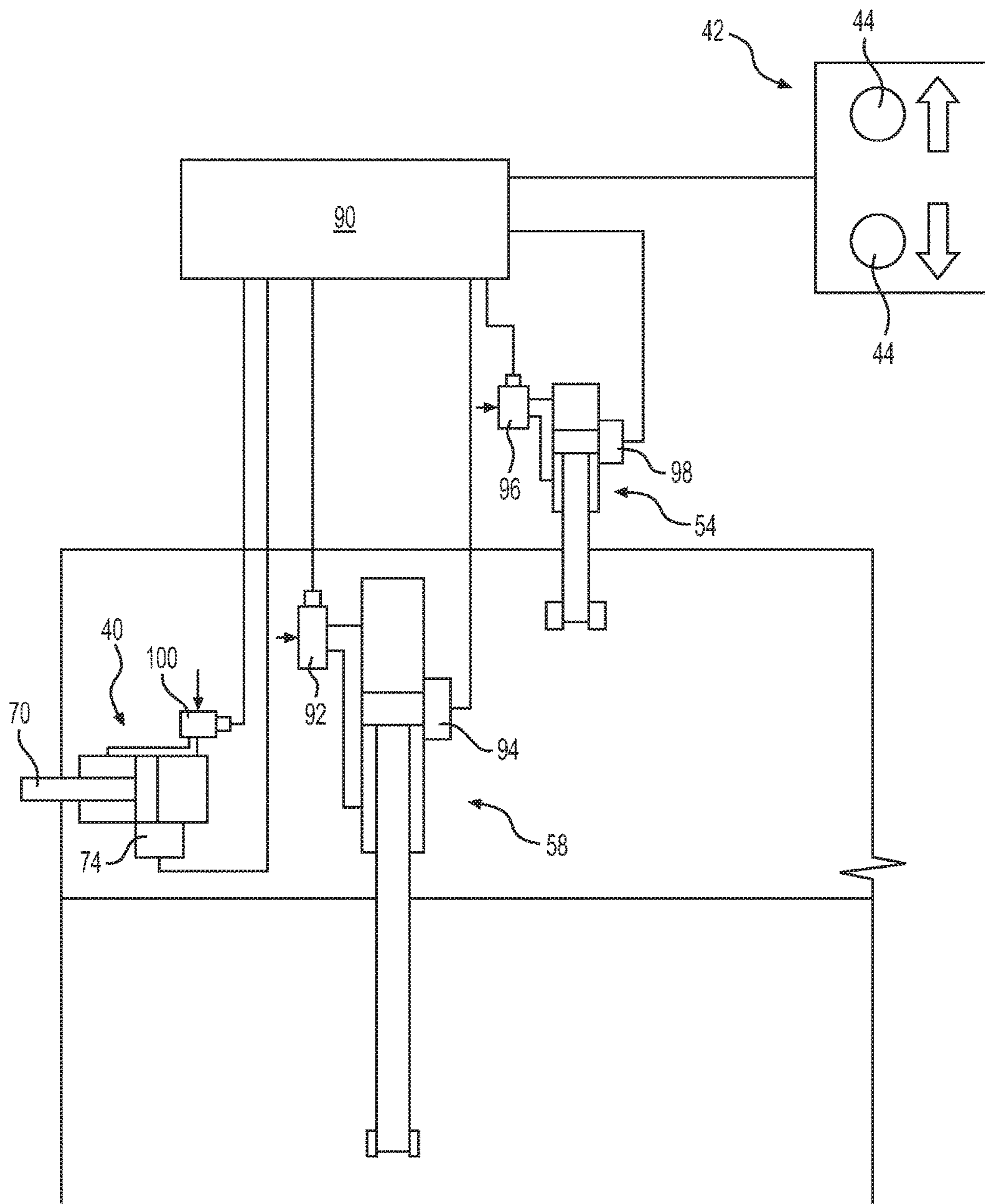

**FIG. 5**

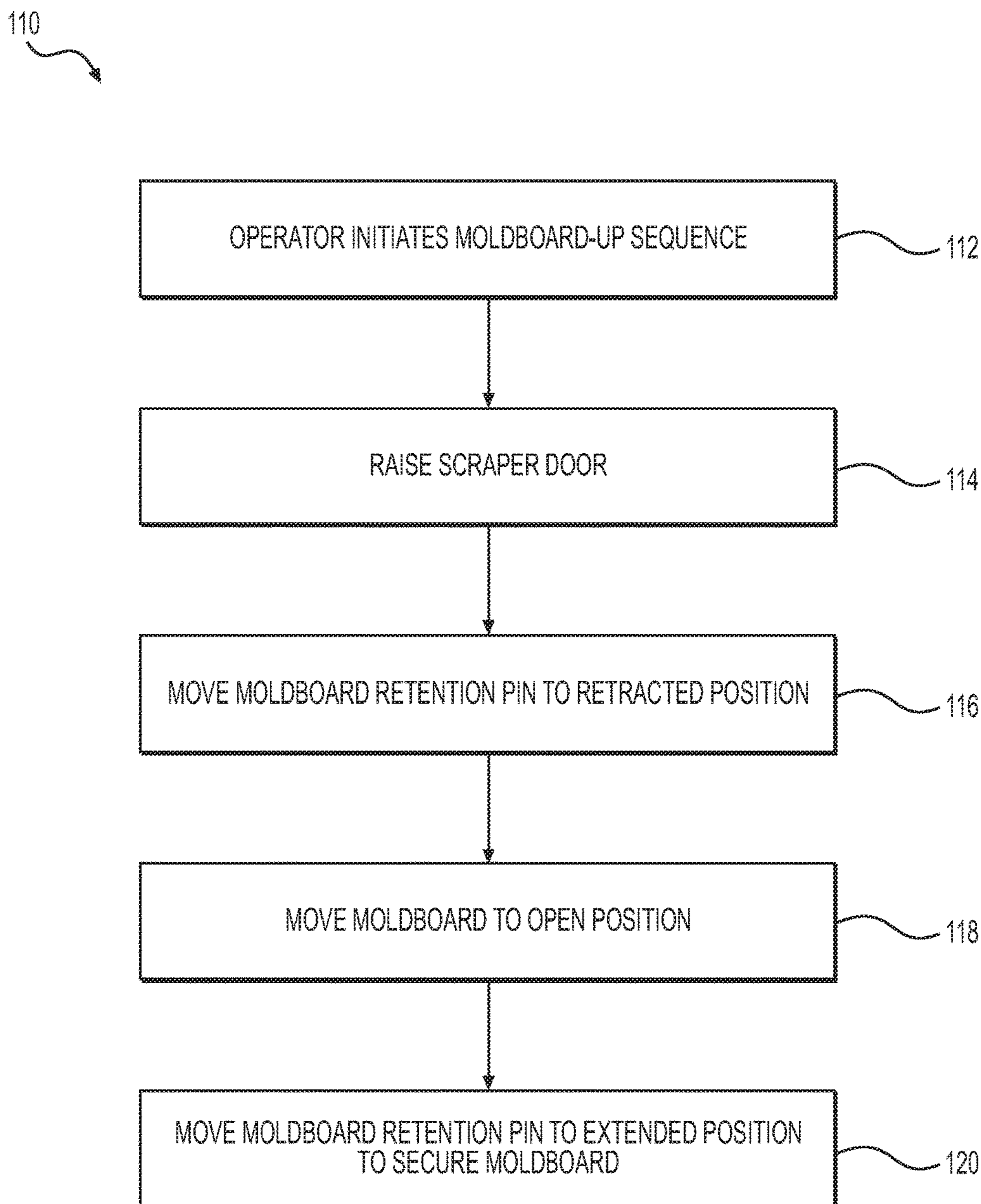

**FIG. 6A**

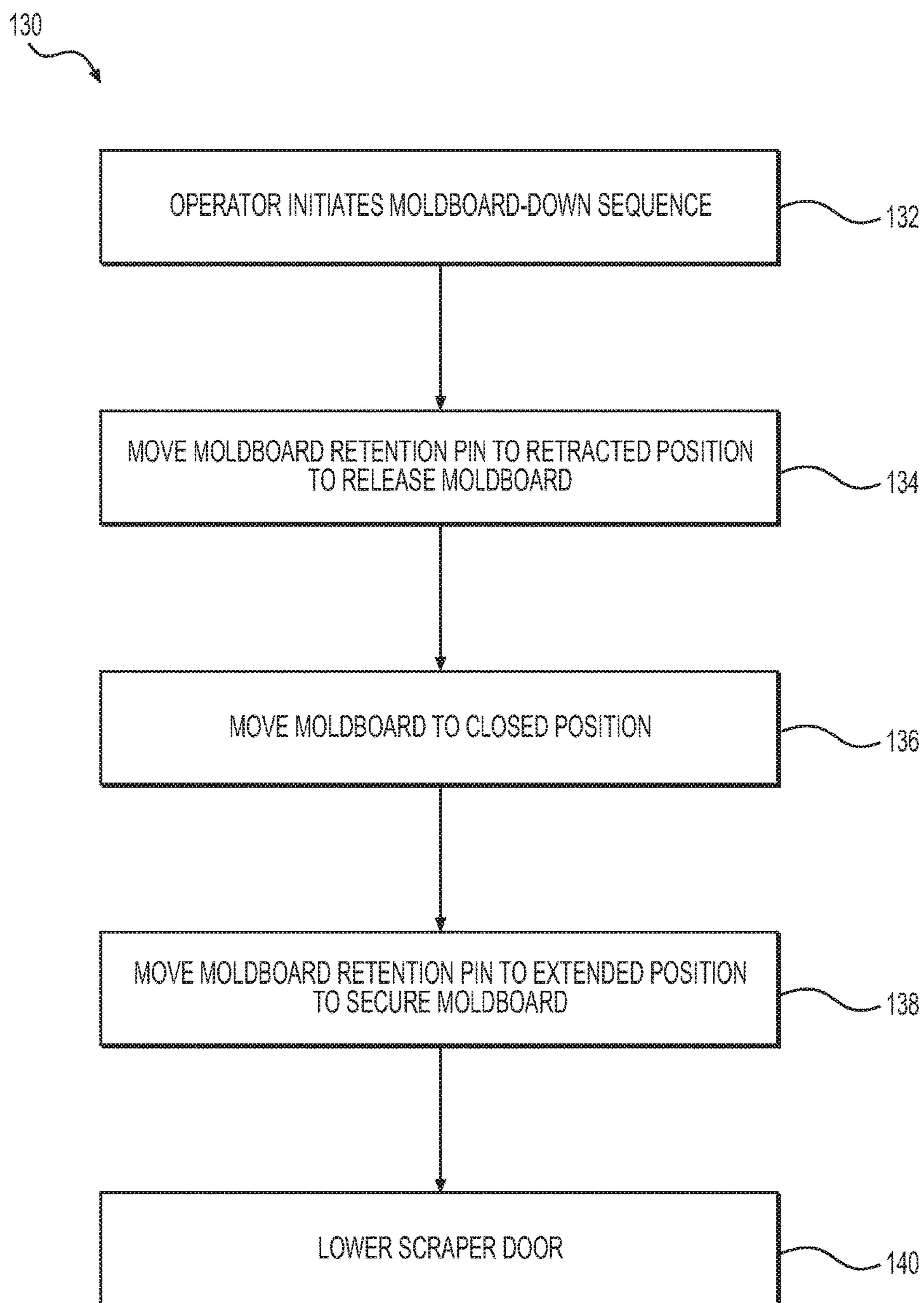

**FIG. 6B**



## MOLDBOARD RETENTION SYSTEM FOR A MILLING MACHINE

### TECHNICAL FIELD

The present disclosure relates generally to moldboard retention system for a milling machine, and more particularly, to a pin assembly for securing the moldboard in both an open and closed position.

### BACKGROUND

The present disclosure relates to milling machines that are used in road surface preparation or repairs. Milling machines are typically used to remove a layer or layers of ground surface or old or defective road surface in preparation for road formation or resurfacing. Many milling machines include a rotor having rotor bits for breaking up the ground surface, and include a rotor chamber to help direct the milled material toward a conveyor or back toward the surface. Such rotor chambers may include chamber walls that surround the rotor. The chamber walls may include a moldboard at the rear of the chamber that is movable between a closed position for milling, and an open position for access to the rotor for inspection and/or repair.

U.S. Pat. No. 5,474,397, issued to Lyons on Dec. 12, 1995 (“the ’397 patent”), describes a mobile milling machine 1 for milling a road surface that includes a floating moldboard 20 for directing milled material onto a loading device 30 positioned behind the machine. The moldboard 20 is vertically movable between a top and bottom stop positions, and is pivotable about a horizontal axis at the top stop position to expose the milling roller 10 for repairs. A locking pin 84 is slidably positioned in a housing 86 fastened to moldboard 20. Pin 84 can be extended into an adjacent slot 88 in the adjacent frame rail 14. The pin 84 is locked in place by a removable key 90 that extends through housing 86 and blocks movement of pin 84. With pin 84 in the slot 88 moldboard 20 can only move vertically. Removal of pin 84 from slot 88 permits moldboard 20 to pivot outwardly and upwardly, as shown in FIG. 4 of the ’397 patent. However, the pin 84 securement of the ’397 patent suffers drawbacks in its manual nature and lack of full securement in the moldboard closed and pivoted positions.

The moldboard retention system of the present disclosure may solve one or more of the problems set forth above and/or other problems in the art. The scope of the current disclosure, however, is defined by the attached claims, and not by the ability to solve any specific problem.

### SUMMARY

In one aspect of the present disclosure, a milling machine includes a frame, a ground-engaging rotor assembly coupled to the frame, and a rotor chamber surrounding the ground-engaging rotor assembly. The rotor chamber includes a moldboard having a top, a bottom, and two sides positioned between the top and the bottom, and the moldboard further having an open position and a closed position. The rotor chamber also includes at least one movable pin secured to the moldboard, the pin being movable by an in-line actuator between a pin extended position and a pin retracted position. Further, the rotor chamber includes a rotor chamber frame wall having an opening located to receive the pin when the pin is in the extended position and the moldboard is in the

closed position, and the receiving of the pin in the rotor chamber frame wall opening secures the moldboard from movement.

According to another aspect of the present disclosure, a milling machine includes a frame, a ground-engaging rotor assembly coupled to the frame, and a rotor chamber surrounding the ground-engaging rotor assembly. The rotor chamber includes a moldboard having a top, a bottom, and two sides positioned between the top and the bottom, and the moldboard further having an open position and a closed position. The rotor chamber also includes at least one hydraulic actuator secured to the moldboard, the hydraulic actuator having a cylinder end and a rod, with the hydraulic actuator being movable between a rod extended position and a rod retracted position. The rotor chamber further includes a first frame wall having an opening located to receive the rod end when the hydraulic actuator is in the extended position and the moldboard is in the closed position, the receiving of the rod in the first frame wall opening secures the moldboard from movement. Further, the rotor chamber includes a second frame wall having an opening located to receive the rod end when the hydraulic actuator is in the extended position and the moldboard is in the open position, the receiving of the rod in the second frame wall opening secures the moldboard from movement.

According to yet another aspect of the present disclosure, a method of operating a milling machine is provided, wherein the milling machine includes a operator control, a moldboard, a scraper door coupled to the moldboard, and a pin assembly coupled to the moldboard. The method includes receiving a signal from the operator control corresponding to a requested moldboard-up sequence. The following sequence is performed in response to the signal: raising the scraper door; moving a pin of the pin assembly from a pin securing position to a pin releasing position to release the moldboard from a frame wall of the machine; moving the moldboard to an open position; and moving the pin to a securing position to secure the moldboard to another frame wall of the machine when the moldboard is in the open position.

### BRIEF DESCRIPTION OF THE DRAWINGS

FIG. 1 illustrates an exemplary milling machine having a according to the present disclosure;

FIG. 2 illustrates the moldboard of the milling machine of FIG. 1 in the closed position;

FIG. 3 illustrates an exemplary pin assembly of the moldboard retention system of FIG. 1;

FIG. 4 illustrates the moldboard of the milling machine of FIG. 1 in the open position;

FIG. 5 illustrates an exemplary moldboard control system for the milling machine of FIG. 1;

FIG. 6A shows an exemplary process for moving the moldboard between closed and open positions; and

FIG. 6B shows an exemplary process for moving the moldboard between open and closed positions.

### DETAILED DESCRIPTION

Both the foregoing general description and the following detailed description are exemplary and explanatory only and are not restrictive of the features, as claimed. As used herein, the terms “comprises,” “comprising,” “having,” “including,” or other variations thereof, are intended to cover a non-exclusive inclusion such that a process, method, article, or apparatus that comprises a list of elements does not

include only those elements, but may include other elements not expressly listed or inherent to such a process, method, article, or apparatus.

For the purpose of this disclosure, the term “ground surface” is broadly used to refer to all types of surfaces that form typical roadways (e.g., asphalt, cement, clay, sand, dirt, etc.) or can be milled in the removal or formation of roadways. In this disclosure, relative terms, such as, for example, “about,” “substantially,” “generally,” and “approximately” are used to indicate a possible variation of  $\pm 10\%$  in a stated value or characteristic. The current disclosure is described with reference to a milling machine. As used herein, a milling machine includes any machine that includes a ground engaging rotor or cutter to displace ground surfaces. Examples of such milling machines include cold planers and ground reclaimers.

FIG. 1 illustrates an exemplary milling machine 10 according to the present disclosure. Machine 10 includes a frame 12 supporting an operator station 14, and a milling assembly 16 coupled to an underside of the frame 12. Machine 10 also includes a conveyor assembly 18 configured to advance milled material from milling assembly 16 away from the ground surface 20, for example, to be deposited into a bed of a truck (not shown). Machine 10 includes a plurality of track members or wheels 22 coupled to frame 12 via hydraulic cylinders 24.

Milling assembly 16 may include a ground-engaging rotor or cutter 26 having rotor bits 28. The rotor 26 may be enclosed within a series of walls forming a rotor chamber 30. The walls of the rotor chamber 30 may include, inter alia, front and side frame walls 32, adjustable side plates 34 extending below the side frame walls 32, a moldboard 36 (shown in dashed lines) at the rear of the rotor chamber 30, and an adjustable scraper door 38 (shown in dashed lines) extending below the moldboard 36. During operation, as rotor 26 rotates in ground surface 20, the rotor chamber 30 forms a barrier that retains much of the milled material, and urges the milled material toward the conveyor assembly 18.

As will be explained in more detail below, the moldboard 36 and scraper door 38 may be moved between a closed position extending generally vertically, to an open position extending generally horizontally. These positions are both depicted in dashed lines in FIG. 1. Further, the moldboard 36 may be secured in each of these different positions by a hydraulically actuated pin assembly 40. An ground-located operator panel 42 may include operator controls 44 for controlling the movement of the moldboard 36, scraper door 38, pin assembly 40, and other aspects of rotor chamber 30.

As shown in FIG. 2, moldboard 36 is depicted in the closed position and may include a top 46, bottom 48, and sidewalls 50. Moldboard 36 may further include a pair of hinges 52 and hydraulic actuators 54 for pivoting the moldboard 36 between the open and closed positions. Hydraulic lines are omitted in the figures of this disclosure for clarity. While the opening and closing of moldboard 36 is shown with pivoting hinges 52, it is understood that alternative opening configurations could also be used, such as opening via linear, vertical movement of the moldboard 36. Scraper door 38 is coupled to moldboard 36 so as to allow for a raising and lowering movement 56 of the scraper door 38 between a lowered position (FIG. 2) and a raised or retracted position (FIG. 3). Movement of the scraper door 38 may be provided by, for example, hydraulic actuators 58 coupled at a head end to the moldboard 36 and at the rod end to a bottom portion 60 of the scraper door 38.

The hydraulically actuated pin assembly 40 may be coupled to each of the opposite sidewalls 50 of the mold-

board 36. A single pin assembly 40 will be described below, but it is understood that the description will be equally applicable to both pin assemblies 40. Referring to FIG. 3, pin assembly 40 may include a head end 62 and a rod end 64. Head end 62 may be a conventional head end of a hydraulic actuator with hydraulic fluid connections 66 and 68 located on opposite sides of an internal piston (not shown) that is connected to a retention rod or pin 70. Thus, control of fluid into and out of head end 62 controls the movement 72 and position of the pin 70. A position sensor 74, schematically illustrated in FIG. 3, may be included with pin assembly 40 to assist in determining the linear location of pin 70 between an extended position (shown in FIG. 3) and a retracted position. Position sensor 74 may be any type of conventional position sensor, such as a magnetostrictive, variable-resistance, or variable-inductance type position sensor.

Referring to FIGS. 2 and 3, pin assembly 40 may also include a distal flange 76 fixedly secured to the head end 62 to assist in coupling the pin assembly 40 to sidewall 50. Flange 76 may be coupled to the bottom half of sidewall 50 of moldboard 36 in any conventional manner, such as by welding or bolts. Alternatively, flange 76 may be omitted, and head end 62 may be coupled adjacent to, but not directly on, sidewall 50. A pin opening 78 in flange 76 may be aligned with a pin opening 80 in sidewall 50 and a pin opening 82 in an associated frame wall 32. When the pin 70 is in the extended position, the pin 70 of pin assembly 40 extends through pin openings 78, 80, 82, thereby securing the moldboard 36 to the frame wall 32. The pin openings 78, 80, 82 may be, for example, circular, oval, or any other shape that serves to secure pin 70 and moldboard 36 from any movement when the pin 70 is in the extended position in pin openings 78, 80, 82. As shown in FIG. 3, the pin assembly 40 provides an in-line configuration with the head end 62, pin 70, and pin openings 78, 80, 82 being aligned linearly. Referring back to FIG. 2, another pin opening 84 may be formed in a frame wall 86 at a location corresponding to the moldboard 36 open position. While not shown, another pin opening may be included in a frame wall opposite pin opening 84. As used herein, the term “frame wall” includes any element or feature of milling machine 10 that is stationary relative to moldboard 36. For example, as shown in FIGS. 2 and 4, frame wall 86 may be a portion of a rotor drive support member.

FIG. 4 shows the moldboard 36 secured from movement when the moldboard 36 is in the open position, with the scraper door 38 retracted, and the pin assembly 40 in the extended position within pin opening 84 of frame wall 86. Movement of the moldboard 36 to the open position may be achieved by moving the moldboard hydraulic actuators 54 to a retracted position. As used herein, securing the moldboard 36 from movement means restricting any substantial movement of the moldboard 36. Thus, the moldboard 36 is secured from movement even if there is some clearance or play between pin 70 and the pin opening 82.

FIG. 5 shows an exemplary moldboard control system for the milling machine 10 of FIG. 1. Only half of the moldboard is depicted in FIG. 5, and it is understood that the other half of the moldboard 36 would include the same control system. The control system of FIG. 5 shows a portion of the ground-located operator panel 42 of the milling machine 10. The operator panel 42 may include operator controls 44 that control movement of the moldboard 36, scraper door 38, and pin assemblies 40. Operator controls 44 may include “up” and “down” buttons corresponding to moldboard up and moldboard down operator commands. However, it is under-

5

stood that operator controls 44 can alternatively be one or more of dials, switches, touch displays, or any other conventional operator controls. Operator controls 44 may be electronically coupled to a control unit 90 to send and/or receive signals therefrom. Control unit 90 may also be electronically coupled to send and/or receive signals from: (1) a hydraulic control valve 92 and a position sensor 94 of the scraper door hydraulic actuator 58; (2) a hydraulic control valve 96 and a position sensor 98 of the moldboard hydraulic actuator; and (3) a hydraulic control valve 100 and the position control sensor 74 of the pin assembly 40. Control unit 90 may include a processor, storage, and memory, assembled together in a single device and/or provided separately. The processor may include one or more known processing devices, such as a microprocessor. The memory may include one or more storage devices configured to store information used by the control unit to perform certain functions related to the disclosed system. The storage may include a volatile or non-volatile, magnetic, semiconductor, tape, optical, removable, nonremovable, or other type of storage device or computer-readable medium. Further, the storage may store programs and/or other information, such as information related to processing data received from one or more sensors, as discussed in greater detail below.

#### INDUSTRIAL APPLICABILITY

The disclosed moldboard retention system may be applicable to any machine having a rotor and rotor chamber, and may assist in providing proper operation and safe access to the rotor within the rotor chamber. In particular, the pin assembly 40 provides a straightforward design for securing the moldboard 36 in the open position (FIG. 4) and the closed position (FIG. 2). In particular, the disclosed design provides an in-line securing configuration with minimal linkages, and a readily identified secured-not secured condition. Proper securing of the moldboard 36 in the closed position helps to ensure that milled material is properly contained within the rotor chamber 30 during the milling operation. Further, securing the moldboard in the open position with the pin assembly 40 helps to provide safe access to the rotor 26 during maintenance.

FIGS. 5, 6A and 6B illustrate an exemplary control system and operation of the moldboard retention system of the present disclosure. Moldboard 36 and scraper door 38 may be initially positioned as shown in FIG. 2, with the moldboard 36 in the closed position, and the scraper door 38 in the fully lowered position. Further, the pin assembly 40 is in an extended position securing the moldboard 36 to the frame walls 32 of the milling machine 10. When the milling operation is stopped, the operator can initiate movement of the moldboard 36 into the open position or closed position according to the processes 110 and 130, respectively, of FIGS. 6A and 6B.

Referring to FIG. 6A, the operator can initiate or request the “moldboard-up” sequence (step 112) by depressing an “up” button of operator controls 44 in operator station 14. Once initiated, the moldboard-up sequence may include sending signals from control unit 90 to control valve 92 to actuate the hydraulic actuators 58 to raise the scraper door 38 (step 114). When the control unit 90 receives a signal from position sensor 94 corresponding to a scraper door 38 fully raised position, control unit 90 sends signals to control valve 100 of pin assembly 40 to move the retention pin 70 to the retracted position (step 116). When the control unit 90 receives a signal from position sensor 74 of the pin assembly

6

40 corresponding to pin fully retracted position, signals from control unit 90 are sent to the control valve 96 to actuate the moldboard hydraulic actuator 54 to pivot the moldboard 36 about hinges 52 to an open position as shown in FIG. 4 (step 118). When the control unit 90 receives a signal from position sensor 98 corresponding to a moldboard 36 fully open position, control unit 90 will send signals to control valve 100 of pin assembly 40 to move retention pin 70 to the extended position to secure pin 70 within pin opening 84 of frame wall 86 (step 120). This process is completed when control unit 90 receives a signal from position sensor 74 that pin 70 is in the fully extended position within pin opening 84.

Referring to the exemplary “moldboard-down” process 130 of FIG. 6B, the operator can initiate or request the moldboard-down sequence (step 132) by depressing a “down” button of the operator controls 44 to send a signal to control valve 100 to move retention pin 70 to the retracted position (step 134). When the control unit 90 receives a signal from position sensor 74 of the pin assembly 40 corresponding to pin fully retracted position, signals from control unit 90 are sent to the control valve 96 to actuate the moldboard hydraulic actuators 54 to pivot the moldboard 36 about hinges 52 to the closed position as shown in FIG. 2 (step 136). When the control unit 90 receives a signal from position sensor 98 corresponding to a moldboard 36 fully closed position, control unit 90 will send signals to control valve 100 of pin assembly 40 to move pin 70 to the extended position to secure pin 70 within pin opening 82 of frame wall 32 (step 138), and thus secure the moldboard 36 in the closed position. When the control unit 90 receives a signal from position sensor 74 corresponding to a pin fully extended position, control unit 90 will send signals to control valve 92 of scraper door hydraulic actuators 58 to move the scraper door 38 to an extended position as shown in FIG. 2 (step 140) corresponding to a predetermined position or a operator-desired position.

The above described process steps need not be performed in the order described, but rather certain steps can be performed in a different order and/or can be performed simultaneously with other steps. Further, the operator controls 44 may be configured to require depression or operator input throughout the entire sequence of the process to actuate all of the steps of the sequence, or alternatively, the entire sequence (raising, lowering, and securing the moldboard) may be done automatically after triggering by a single depression or operator action of the operator control 44 at the beginning of the desired sequence.

It will be apparent to those skilled in the art that various modifications and variations can be made to the disclosed machine without departing from the scope of the disclosure. Other embodiments of the machine will be apparent to those skilled in the art from consideration of the specification and practice of the moldboard support structure disclosed herein. For example, while pin assembly 40 is described as hydraulically actuated, any other type of actuator may be used, such as a pneumatic, solenoid, electronic, or piezoelectric type actuator. It is intended that the specification and examples be considered as exemplary only, with a true scope of the disclosure being indicated by the following claims and their equivalents.

What is claimed is:

1. A milling machine, comprising
  - a frame;
  - a ground-engaging rotor assembly coupled to the frame;
  - a rotor chamber surrounding the ground-engaging rotor assembly, the rotor chamber including:

7

a moldboard having a top, a bottom, and two sides positioned between the top and the bottom, the moldboard further having an open position and a closed position;

at least one movable pin secured to the moldboard, the pin being movable by an in-line actuator between a pin extended position and a pin retracted position;

a rotor chamber frame wall having an opening located to receive the pin when the pin is in the extended position and the moldboard is in the closed position, and the receiving of the pin in the rotor chamber frame wall opening secures the moldboard from movement; and

a sensor system associated with the movable pin to determine when the pin is in the pin extended or pin retracted position.

2. The milling machine of claim 1, wherein the in-line actuator is a hydraulic actuator, and the pin is a piston rod of the hydraulic actuator.

3. The milling machine of claim 1, wherein the frame wall is a first frame wall, and the milling machine further including a second frame wall, the second frame wall having an opening located to receive the pin when the pin is in the extended position and the moldboard is in the open position.

4. The milling machine of claim 2, wherein the at least one movable pin is a first movable pin, and the milling machine further includes a second movable pin secured to an opposite side of the moldboard with respect to the first movable pin, the second movable pin being movable by an in-line actuator between an pin extended position and a pin retracted position, and

the rotor chamber frame wall is a first rotor chamber frame wall, and the milling machine further includes a second rotor chamber frame wall opposite the first rotor chamber frame wall, the second rotor chamber frame wall having an opening located to receive the second movable pin when the second pin is in the extended position and the moldboard is in the closed position.

5. The milling machine of claim 1, further including an operator input device for initiating a moldboard-up sequence, the moldboard-up sequence includes moving of the pin to the extended position after one or more moldboard sensors indicate that the moldboard is in the open position.

6. The milling machine of claim 5, further including a scraper door extending from the bottom of the moldboard, the scraper door being movable between a raised position and a lowered position, and the moldboard-up sequence includes moving the moldboard toward the open position after one or more scraper door sensors indicate that the scraper door is raised.

7. The milling machine of claim 6, further including moldboard one or more actuators configured to pivot the moldboard to the open position.

8. A milling machine, comprising

a frame;

a ground-engaging rotor assembly coupled to the frame;

a rotor chamber surrounding the ground-engaging rotor assembly, the rotor chamber including:

a moldboard having a top, a bottom, and two sides positioned between the top and the bottom, the moldboard further having an open position and a closed position;

at least one hydraulic actuator secured to the moldboard, the hydraulic actuator having a cylinder end and a rod, with the hydraulic actuator being movable between a rod extended position and a rod retracted position;

8

a first frame wall having an opening located to receive the rod end when the hydraulic actuator is in the extended position and the moldboard is in the closed position, the receiving of the rod in the first frame wall opening secures the moldboard from movement; and

a second frame wall having an opening located to receive the rod end when the hydraulic actuator is in the extended position and the moldboard is in the open position, the receiving of the rod in the second frame wall opening secures the moldboard from movement.

9. The milling machine of claim 8, wherein the at least one hydraulic actuator is a first hydraulic actuator, and the milling machine further includes a second hydraulic actuator secured to an opposite side of the moldboard with respect to the first hydraulic actuator, the second hydraulic actuator having a cylinder end and a rod end, with the second hydraulic actuator being movable between a rod extended position and a rod retracted position, and

the milling machine further includes a third frame wall opposite the first frame wall, the third frame wall having an opening located to receive the rod end of the second hydraulic actuator when the second actuator is in the extended position and the moldboard is in the closed position.

10. The milling machine of claim 8, further including a sensor system associated with the hydraulic actuator to determine when the hydraulic actuator is in the extended or retracted position.

11. The milling machine of claim 8, further including an operator input device for initiating a moldboard-up sequence, wherein the moldboard-up sequence includes moving of the rod end to the extended position after one or more moldboard sensors indicate that the moldboard is in the open position.

12. The milling machine of claim 11, further including a scraper door extending from the bottom of the moldboard, the scraper door being movable between a raised position and a lowered position, and the moldboard-up sequence includes moving the moldboard toward the open position after one or more scraper door sensors indicate that the scraper door is raised.

13. The milling machine of claim 12, further including moldboard actuators configured to pivot the moldboard to the open position.

14. A method of operating a milling machine, the milling machine having a operator control, a moldboard, a scraper door coupled to the moldboard, and a pin assembly coupled to the moldboard, the method comprising:

receiving a signal from the operator control corresponding to a requested moldboard-up sequence; and

performing the following in response to the signal:

raising the scraper door;

moving a pin of the pin assembly from a pin securing position to a pin releasing position to release the moldboard from a frame wall of the machine;

moving the moldboard to an open position; and

moving the pin to a securing position to secure the moldboard to another frame wall of the machine when the moldboard is in the open position.

15. The method of claim 14, wherein the moving of the moldboard to an open position is initiated after confirming that the pin is in the pin releasing position.

16. The method of claim 15, moving of the pin to the securing position is achieved via hydraulic actuation.

**17.** The method of claim **14**, further including receiving a signal from the operator control corresponding to a requested moldboard-down sequence; and

performing the following in response to the moldboard-down signal: 5

moving the pin of the pin assembly from a pin securing position to a pin releasing position to release the moldboard from the another frame wall of the machine;

moving the moldboard to a closed position; 10

moving the pin to a securing position to secure the moldboard to the frame wall of the machine, when the moldboard is in the closed position; and

lowering the scraper door.

**18.** The method of claim **17**, wherein moving the moldboard to a closed position is initiated after confirming that the pin is in the pin releasing position. 15

**19.** The method of claim **18**, moving of the pin to the securing position is achieved via hydraulic actuation.

\* \* \* \* \*

20