



US010327911B2

(12) **United States Patent**  
**Voellmicke et al.**

(10) **Patent No.:** **US 10,327,911 B2**  
(45) **Date of Patent:** **Jun. 25, 2019**

(54) **ENHANCED CAGE INSERTION ASSEMBLY**

(71) Applicant: **DePuy Synthes Products, Inc.**,  
Raynham, MA (US)

(72) Inventors: **John C Voellmicke**, Franklin, MA  
(US); **Michael J O'Neil**, West  
Barnstable, MA (US); **Derek Shaw**,  
North Attleboro, MA (US); **Alexander  
Grinberg**, Auburndale, MA (US)

(73) Assignee: **DePuy Synthes Products, Inc.**,  
Raynham, MA (US)

(\*) Notice: Subject to any disclaimer, the term of this  
patent is extended or adjusted under 35  
U.S.C. 154(b) by 0 days.

(21) Appl. No.: **15/653,586**

(22) Filed: **Jul. 19, 2017**

(65) **Prior Publication Data**

US 2017/0319356 A1 Nov. 9, 2017

**Related U.S. Application Data**

(63) Continuation of application No. 14/623,982, filed on  
Feb. 17, 2015, now Pat. No. 9,833,334, which is a  
(Continued)

(51) **Int. Cl.**  
**A61B 17/58** (2006.01)  
**A61B 17/60** (2006.01)  
(Continued)

(52) **U.S. Cl.**  
CPC ..... **A61F 2/4455** (2013.01); **A61F 2/447**  
(2013.01); **A61F 2/4601** (2013.01);  
(Continued)

(58) **Field of Classification Search**  
CPC ... A61B 17/88; A61B 17/885; A61B 17/8875;  
A61B 17/8894; A61B 2017/90;  
(Continued)

(56) **References Cited**  
U.S. PATENT DOCUMENTS  
3,867,728 A 2/1975 Stubstad et al.  
4,349,921 A 9/1982 Kuntz  
(Continued)

**FOREIGN PATENT DOCUMENTS**

CN 101909548 A 12/2010  
DE 2804936 8/1979  
(Continued)

**OTHER PUBLICATIONS**

Chiang, Biomechanical Comparison of Instrumented Posterior Lum-  
bar Interbody Fusion with One or Two Cages by Finite Element  
Analysis, Spine, 2006, pp. E682-E689, vol. 31(19), Lippincott  
Williams & Wilkins, Inc.

(Continued)

*Primary Examiner* — Julianna N Harvey  
*Assistant Examiner* — Christina Negrellirodriguez

(57) **ABSTRACT**  
An inserter instrument for inserting an intervertebral fusion  
cage having curved sidewalls, comprising:  
a) a threaded securement rod that mates with the cage via  
screw threads;  
b) a cannulated cage holder to receive the rod and hold the  
cage in position as the sheath is retracted; and  
c) a bulleted cannulated sheath,  
wherein the sheath is curved and comprises a superelastic  
shape memory material having a curved configuration and a  
straight configuration.

**4 Claims, 12 Drawing Sheets**

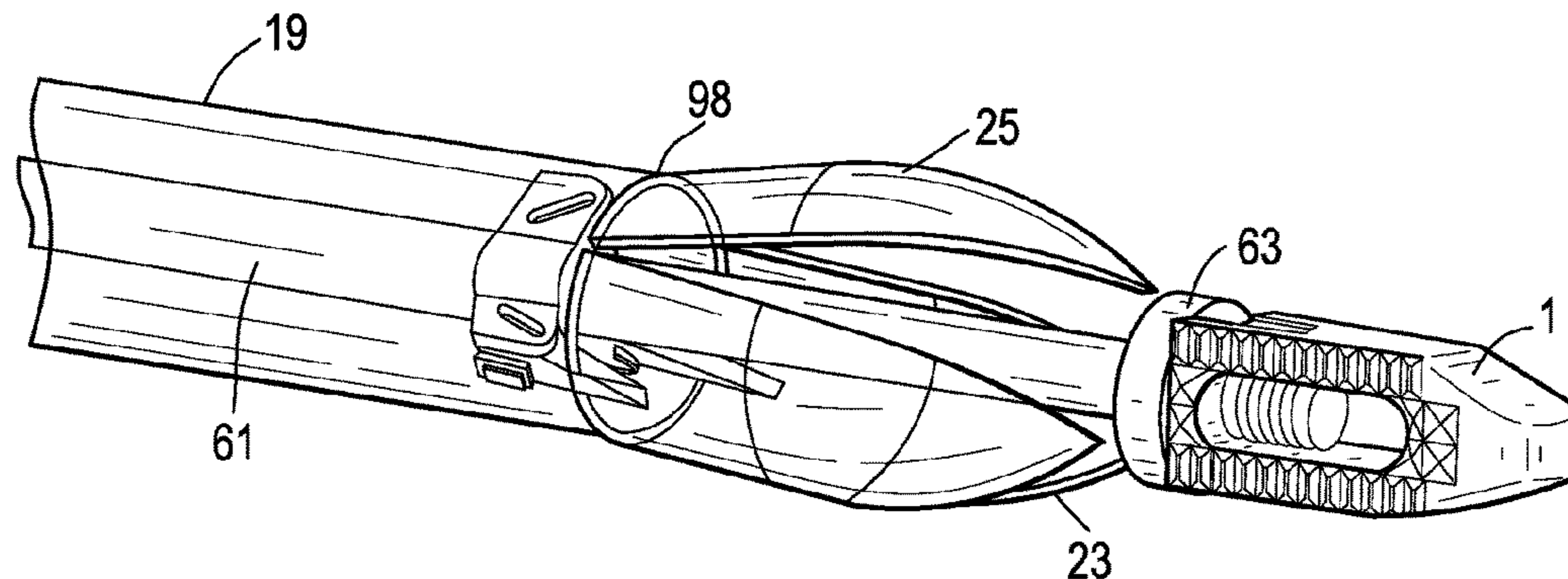

**Related U.S. Application Data**

continuation of application No. 12/822,739, filed on Jun. 24, 2010, now Pat. No. 8,979,860.

(51) **Int. Cl.**

*A61F 2/00* (2006.01)  
*A61F 2/44* (2006.01)  
*A61F 2/46* (2006.01)  
*A61F 2/30* (2006.01)

(52) **U.S. Cl.**

CPC ..... *A61F 2/4611* (2013.01); *A61F 2/446* (2013.01); *A61F 2/4465* (2013.01); *A61F 2002/30034* (2013.01); *A61F 2002/30092* (2013.01); *A61F 2002/30331* (2013.01); *A61F 2002/30604* (2013.01); *A61F 2002/30731* (2013.01); *A61F 2002/448* (2013.01); *A61F 2002/4475* (2013.01); *A61F 2310/00017* (2013.01); *A61F 2310/00023* (2013.01); *A61F 2310/00239* (2013.01)

(58) **Field of Classification Search**

CPC ..... *A61F 2/4455*; *A61F 2/4465*; *A61F 2/447*; *A61F 2002/4475*; *A61F 2002/4625*; *A61F 2002/4627*; *A61F 2002/4628*; *A61F 2/4611*  
 USPC ..... 606/90, 96, 99, 104, 86 A; 623/17.11–17.16

See application file for complete search history.

(56)

**References Cited**

U.S. PATENT DOCUMENTS

4,743,256 A 5/1988 Brantigan  
 4,759,766 A 7/1988 Buettner-Janz et al.  
 4,863,476 A 9/1989 Shepperd  
 4,871,366 A 10/1989 von Recum et al.  
 4,878,915 A 11/1989 Brantigan  
 5,059,193 A 10/1991 Kuslich  
 5,071,437 A 12/1991 Steffee  
 5,123,926 A 6/1992 Pisharodi  
 5,290,312 A 3/1994 Kojimoto et al.  
 5,314,477 A 5/1994 Marnay  
 5,344,252 A 9/1994 Kakimoto  
 5,370,697 A 12/1994 Baumgartner  
 5,390,683 A 2/1995 Pisharodi  
 5,401,269 A 3/1995 Buttner-Janz et al.  
 5,425,773 A 6/1995 Boyd et al.  
 5,443,514 A 8/1995 Steffee  
 5,507,816 A 4/1996 Bullivant  
 5,522,899 A 6/1996 Michelson  
 5,534,029 A 7/1996 Shima  
 5,554,191 A 9/1996 Lahille et al.  
 5,556,431 A 9/1996 Buttner-Janz  
 5,562,738 A 10/1996 Boyd et al.  
 5,609,635 A 3/1997 Michelson  
 5,653,763 A 8/1997 Errico  
 5,658,335 A 8/1997 Allen  
 5,665,122 A 9/1997 Kambin  
 5,676,701 A 10/1997 Yuan et al.  
 5,683,465 A 11/1997 Shinn et al.  
 5,697,977 A 12/1997 Pisharodi  
 5,716,415 A 2/1998 Steffee  
 5,772,661 A 6/1998 Michelson  
 5,782,832 A 7/1998 Larsen et al.  
 5,797,909 A 8/1998 Michelson  
 5,860,973 A 1/1999 Michelson  
 5,865,848 A 2/1999 Baker  
 5,888,224 A 3/1999 Beckers et al.  
 5,888,226 A 3/1999 Rogozinski  
 5,888,227 A 3/1999 Cottle  
 5,893,889 A 4/1999 Harrington  
 5,893,890 A 4/1999 Pisharodi

5,980,522 A 11/1999 Koros et al.  
 5,989,291 A 11/1999 Ralph et al.  
 6,039,761 A 3/2000 Li  
 6,039,763 A 3/2000 Shelokov  
 6,045,579 A 4/2000 Hochshuler  
 6,080,155 A 6/2000 Michelson  
 6,083,225 A 7/2000 Winslow  
 6,096,038 A 8/2000 Micheson  
 6,099,531 A 8/2000 Bonutti  
 6,102,950 A 8/2000 Vaccaro  
 6,106,557 A 8/2000 Robioneck et al.  
 6,113,637 A 9/2000 Gill et al.  
 6,113,638 A 9/2000 Williams et al.  
 6,117,174 A 9/2000 Nolan  
 6,127,597 A 10/2000 Beyar et al.  
 6,129,763 A 10/2000 Chauvin et al.  
 6,146,387 A 11/2000 Trott et al.  
 6,176,882 B1 1/2001 Biedermann et al.  
 6,179,794 B1 1/2001 Burras  
 6,179,873 B1 1/2001 Zientek  
 6,183,517 B1 2/2001 Suddaby  
 6,193,757 B1 2/2001 Foley et al.  
 6,296,647 B1 10/2001 Robioneck et al.  
 6,302,914 B1 10/2001 Michelson  
 6,332,895 B1 12/2001 Suddaby  
 6,368,350 B1 4/2002 Erickson et al.  
 6,368,351 B1 4/2002 Glenn  
 6,375,682 B1 4/2002 Fleischmann et al.  
 6,387,130 B1 5/2002 Stone  
 6,409,766 B1 6/2002 Brett  
 6,419,705 B1 7/2002 Erickson  
 6,419,706 B1 7/2002 Graf  
 6,436,140 B1 8/2002 Liu et al.  
 6,454,806 B1 9/2002 Cohen et al.  
 6,454,807 B1 9/2002 Jackson  
 6,468,310 B1 10/2002 Ralph et al.  
 6,488,710 B2 12/2002 Besselink  
 6,517,580 B1 2/2003 Ramadan et al.  
 6,527,804 B1 3/2003 Gauchet et al.  
 6,533,818 B1 3/2003 Weber et al.  
 6,558,424 B2 5/2003 Thalgott  
 6,562,074 B2 5/2003 Gerbec et al.  
 6,582,468 B1 6/2003 Gauchet  
 6,610,094 B2 8/2003 Husson  
 6,641,614 B1 11/2003 Wagner et al.  
 6,648,917 B2 11/2003 Gerbec et al.  
 6,669,732 B2 12/2003 Serhan et al.  
 6,676,665 B2 1/2004 Foley et al.  
 6,706,070 B1 3/2004 Wagner et al.  
 6,719,796 B2 4/2004 Cohen et al.  
 6,723,126 B1 4/2004 Berry  
 6,733,532 B1 5/2004 Gauchet et al.  
 6,740,117 B2 5/2004 Ralph et al.  
 6,743,255 B2 6/2004 Ferree  
 6,773,460 B2 8/2004 Jackson  
 6,793,678 B2 9/2004 Hawkins  
 6,805,714 B2 10/2004 Sutcliffe  
 6,824,565 B2 11/2004 Muhanna  
 6,855,167 B2 2/2005 Shimp  
 6,863,673 B2 3/2005 Gerbec et al.  
 6,881,229 B2 4/2005 Khandkar et al.  
 6,893,464 B2 5/2005 Kiestler  
 6,936,071 B1 8/2005 Marnay et al.  
 6,953,477 B2 10/2005 Berry  
 6,955,691 B2 10/2005 Chae et al.  
 6,969,404 B2 11/2005 Ferree  
 6,969,405 B2 11/2005 Suddaby  
 7,008,431 B2 3/2006 Simonson  
 7,018,412 B2 3/2006 Ferreira et al.  
 7,018,416 B2 3/2006 Hanson et al.  
 7,037,339 B2 5/2006 Houfburg et al.  
 7,083,650 B2 8/2006 Moskowitz et al.  
 7,094,257 B2 8/2006 Mujwid et al.  
 7,156,876 B2 1/2007 Moumene et al.  
 7,211,112 B2 5/2007 Baynham et al.  
 7,217,293 B2 5/2007 Branch  
 7,220,280 B2 5/2007 Kast et al.  
 7,223,292 B2 5/2007 Messerli et al.  
 7,226,483 B2 6/2007 Gerber et al.

(56)

References Cited

U.S. PATENT DOCUMENTS

7,235,101 B2	6/2007	Berry et al.	8,518,120 B2	8/2013	Glerum et al.
7,300,440 B2	11/2007	Zdeblick	8,551,173 B2	10/2013	Lechmann et al.
7,326,248 B2	2/2008	Michelson	8,556,979 B2	10/2013	Glerum et al.
7,445,636 B2	11/2008	Michelson	8,568,481 B2	10/2013	Olmos et al.
7,503,933 B2	3/2009	Michelson	8,579,977 B2	11/2013	Fabian
7,507,241 B2	3/2009	Levy et al.	8,579,981 B2	11/2013	Lim
7,517,363 B2	3/2009	Rogers	8,591,585 B2	11/2013	McLaughlin et al.
7,569,054 B2	8/2009	Michelson	8,603,170 B2	12/2013	Cipoletti et al.
7,569,074 B2	8/2009	Eisermann et al.	8,623,091 B2	1/2014	Suedkamp et al.
7,618,458 B2	11/2009	Biedermann et al.	8,628,576 B2	1/2014	Triplett et al.
7,621,950 B1	11/2009	Globerman et al.	8,628,578 B2	1/2014	Miller et al.
7,621,960 B2	11/2009	Boyd et al.	8,632,595 B2	1/2014	Weiman
7,691,147 B2	4/2010	Gutlin et al.	8,663,329 B2	3/2014	Ernst
7,703,727 B2	4/2010	Selness	8,668,740 B2	3/2014	Rhoda et al.
7,722,612 B2	5/2010	Sala et al.	8,679,183 B2	3/2014	Glerum et al.
7,722,674 B1	5/2010	Grotz	8,685,098 B2	4/2014	Glerum et al.
7,749,270 B2	7/2010	Peterman	8,696,751 B2	4/2014	Ashley et al.
7,771,473 B2	8/2010	Thramann	8,709,086 B2	4/2014	Glerum et al.
7,785,368 B2	8/2010	Schaller	8,715,351 B1	5/2014	Pinto
7,789,914 B2	9/2010	Michelson	8,721,723 B2	5/2014	Hansell et al.
7,799,083 B2	9/2010	Smith et al.	8,728,160 B2	5/2014	Globerman et al.
7,819,921 B2	10/2010	Grotz	8,753,398 B2	6/2014	Gordon et al.
7,824,445 B2	11/2010	Biro et al.	8,771,360 B2	7/2014	Jimenez et al.
7,837,734 B2	11/2010	Zucherman et al.	8,778,025 B2	7/2014	Ragab et al.
7,846,206 B2	12/2010	Oglaza et al.	8,795,366 B2	8/2014	Varela
7,850,733 B2	12/2010	Baynham et al.	8,828,085 B1	9/2014	Jensen
7,854,766 B2	12/2010	Moskowitz et al.	8,845,731 B2	9/2014	Weiman
7,857,840 B2	12/2010	Krebs	8,845,732 B2	9/2014	Weiman
7,874,980 B2	1/2011	Sonnenschein et al.	8,845,734 B2	9/2014	Weiman
7,879,098 B1	2/2011	Simmons	8,852,279 B2	10/2014	Weiman
7,887,589 B2	2/2011	Glenn et al.	8,852,279 B2	10/2014	Glerum et al.
7,892,239 B2*	2/2011	Warnick ..... A61F 2/4465 606/279	8,864,833 B2	10/2014	Glerum et al.
7,909,870 B2	3/2011	Kraus	8,888,853 B2	11/2014	Glerum et al.
7,922,729 B2	4/2011	Michelson	8,888,854 B2	11/2014	Glerum et al.
7,951,199 B2	5/2011	Miller	8,900,307 B2	12/2014	Hawkins et al.
7,985,231 B2	7/2011	Sankaran	8,926,704 B2	1/2015	Glerum
7,993,403 B2	8/2011	Foley et al.	8,936,641 B2	1/2015	Cain
8,021,424 B2	9/2011	Beger et al.	8,940,052 B2	1/2015	Lechmann et al.
8,021,426 B2	9/2011	Segal et al.	8,979,860 B2	3/2015	Voellmicke ..... A61F 2/4455 606/99
8,025,697 B2	9/2011	McClellan et al.	9,039,771 B2	5/2015	Glerum et al.
8,034,109 B2	10/2011	Zwirkoski	9,091,488 B2	7/2015	Postma et al.
8,043,381 B2	10/2011	Hestad et al.	9,095,446 B2	8/2015	Landry et al.
8,062,375 B2	11/2011	Glerum et al.	9,095,447 B2	8/2015	Barreiro et al.
8,075,621 B2	12/2011	Michelson	2002/0010070 A1	1/2002	Cales et al.
8,105,382 B2	1/2012	Olmos et al.	2002/0068976 A1	6/2002	Jackson
8,114,088 B2	2/2012	Miller	2002/0068977 A1	6/2002	Jackson
8,177,812 B2	5/2012	Sankaran	2002/0128715 A1	9/2002	Bryan et al.
8,192,495 B2	6/2012	Simpson et al.	2002/0128716 A1	9/2002	Cohen et al.
8,221,501 B2	7/2012	Eisermann et al.	2002/0138146 A1	9/2002	Jackson
8,221,502 B2	7/2012	Branch	2002/0151976 A1	10/2002	Foley et al.
8,231,681 B2	7/2012	Castleman et al.	2002/0165612 A1	11/2002	Gerber et al.
8,236,058 B2	8/2012	Fabian et al.	2003/0004575 A1	1/2003	Erickson
8,241,358 B2	8/2012	Butler et al.	2003/0004576 A1	1/2003	Thalgott
8,257,442 B2	9/2012	Edie et al.	2003/0023305 A1	1/2003	McKay
8,262,666 B2	9/2012	Baynham et al.	2003/0040799 A1	2/2003	Boyd et al.
8,267,939 B2	9/2012	Cipoletti et al.	2003/0065396 A1	4/2003	Michelson
8,273,128 B2	9/2012	Oh et al.	2003/0078667 A1	4/2003	Manasas et al.
8,287,599 B2	10/2012	McGuckin	2003/0130739 A1	7/2003	Gerbec et al.
8,303,663 B2	11/2012	Jimenez et al.	2003/0135275 A1	7/2003	Garcia
8,323,345 B2	12/2012	Sledge	2003/0139812 A1	7/2003	Garcia
8,328,852 B2	12/2012	Zehavi et al.	2003/0139813 A1	7/2003	Messerli et al.
8,337,559 B2	12/2012	Hansell et al.	2003/0204261 A1	10/2003	Eiserman
8,353,961 B2	1/2013	McClintock	2003/0233145 A1	12/2003	Landry et al.
8,382,842 B2	2/2013	Greenhalgh et al.	2004/0030387 A1	2/2004	Landry et al.
8,398,713 B2	3/2013	Weiman	2004/0064144 A1	4/2004	Johnson et al.
8,403,990 B2	3/2013	Dryer et al.	2004/0087947 A1	5/2004	Lim
8,409,291 B2	4/2013	Blackwell et al.	2004/0088055 A1	5/2004	Hanson et al.
8,435,298 B2	5/2013	Weiman	2004/0127991 A1	7/2004	Ferree
8,454,617 B2	6/2013	Schaller	2004/0153065 A1	8/2004	Lim
8,486,148 B2	7/2013	Butler et al.	2004/0153156 A1	8/2004	Cohen et al.
8,491,657 B2	7/2013	Attia et al.	2004/0162618 A1	8/2004	Mujwid et al.
8,491,659 B2	7/2013	Weiman	2004/0172133 A1	9/2004	Gerber et al.
8,506,635 B2	8/2013	Palmatier et al.	2004/0186570 A1	9/2004	Rapp
8,518,087 B2	8/2013	Morgenstern et al.	2004/0186577 A1	9/2004	Ferree
			2004/0230309 A1	11/2004	DiMauro
			2005/0019365 A1	1/2005	Frauchiger et al.
			2005/0038515 A1	2/2005	Kunzler
			2005/0113916 A1	5/2005	Branch
			2005/0113917 A1	5/2005	Chae et al.

(56)

## References Cited

U.S. PATENT DOCUMENTS			
2005/0125062	A1	6/2005	Biedermann et al.
2005/0165485	A1	7/2005	Trieu
2005/0222681	A1	10/2005	Richley et al.
2005/0256576	A1	11/2005	Moskowitz et al.
2005/0261769	A1	11/2005	Moskowitz et al.
2005/0278026	A1	12/2005	Gordon et al.
2006/0058876	A1	3/2006	McKinley
2006/0058880	A1	3/2006	Wysocki
2006/0100706	A1	5/2006	Shaddock et al.
2006/0122701	A1	6/2006	Kiester
2006/0122703	A1	6/2006	Aebi et al.
2006/0129244	A1	6/2006	Ensign
2006/0136062	A1	6/2006	DiNello et al.
2006/0142858	A1	6/2006	Colleran et al.
2006/0206207	A1	9/2006	Dryer et al.
2006/0235531	A1	10/2006	Buettner
2006/0253201	A1	11/2006	McLuen
2006/0265075	A1	11/2006	Baumgartner et al.
2006/0265077	A1	11/2006	Zwirkoski
2007/0010886	A1	1/2007	Banick et al.
2007/0055377	A1	3/2007	Hanson et al.
2007/0118222	A1	5/2007	Lang
2007/0149978	A1	6/2007	Shezifi et al.
2007/0173939	A1	7/2007	Kim et al.
2007/0173940	A1	7/2007	Hestad et al.
2007/0178222	A1	8/2007	Storey et al.
2007/0191959	A1	8/2007	Hartmann et al.
2007/0198089	A1	8/2007	Moskowitz et al.
2007/0208423	A1	9/2007	Messerli et al.
2007/0219634	A1	9/2007	Greenhalgh et al.
2007/0233244	A1	10/2007	Lopez et al.
2007/0270968	A1	11/2007	Baynham et al.
2007/0276375	A1	11/2007	Rapp
2007/0299521	A1	12/2007	Glenn
2008/0009877	A1	1/2008	Sankaran et al.
2008/0015701	A1	1/2008	Garcia et al.
2008/0021556	A1	1/2008	Edie
2008/0021558	A1	1/2008	Thramann
2008/0027550	A1	1/2008	Link et al.
2008/0033440	A1	2/2008	Moskowitz et al.
2008/0058944	A1	3/2008	Duplessis et al.
2008/0065219	A1	3/2008	Dye
2008/0082173	A1	4/2008	Delurio et al.
2008/0132934	A1	6/2008	Reilly
2008/0140207	A1	6/2008	Olmos
2008/0147193	A1	6/2008	Matthis et al.
2008/0154377	A1	6/2008	Voellmicke et al.
2008/0161927	A1	7/2008	Savage
2008/0167657	A1	7/2008	Greenhalgh
2008/0177388	A1	7/2008	Patterson et al.
2008/0183204	A1	7/2008	Greenhalgh et al.
2008/0195209	A1	8/2008	Garcia et al.
2008/0243251	A1	10/2008	Stad et al.
2008/0243254	A1	10/2008	Butler
2008/0249622	A1	10/2008	Gray
2008/0281425	A1	11/2008	Thalgott
2009/0005873	A1	1/2009	Slivka et al.
2009/0030423	A1	1/2009	Puno
2009/0054991	A1	2/2009	Biyani
2009/0076610	A1	3/2009	Afzal
2009/0099568	A1	4/2009	Lowry et al.
2009/0105712	A1	4/2009	Dauster
2009/0112320	A1	4/2009	Kraus
2009/0112324	A1	4/2009	Refai et al.
2009/0164020	A1	6/2009	Janowski
2009/0177284	A1	7/2009	Rogers et al.
2009/0198339	A1	8/2009	Kleiner
2009/0222096	A1	9/2009	Trieu
2009/0222099	A1	9/2009	Liu et al.
2009/0234398	A1	9/2009	Chirico et al.
2009/0240335	A1	9/2009	Arcenio et al.
2009/0248159	A1	10/2009	Aflatoon
2009/0292361	A1	11/2009	Lopez et al.
2010/0016905	A1	1/2010	Greenhalgh et al.
2010/0069914	A1	3/2010	Puno
2010/0076559	A1	3/2010	Bagga
2010/0114105	A1	5/2010	Butters
2010/0179594	A1	7/2010	Theofilos et al.
2010/0204795	A1	8/2010	Greenhalgh
2010/0234956	A1	9/2010	Attia et al.
2010/0262240	A1	10/2010	Chavatte et al.
2010/0286783	A1	11/2010	Lechmann et al.
2010/0324607	A1	12/2010	Davis
2011/0004308	A1	1/2011	Marino et al.
2011/0004310	A1	1/2011	Michelson
2011/0015747	A1	1/2011	McManus et al.
2011/0029082	A1	2/2011	Hall
2011/0035011	A1	2/2011	Cain
2011/0093074	A1	4/2011	Glerum et al.
2011/0130835	A1	6/2011	Ashley et al.
2011/0130838	A1	6/2011	Morgenstern
2011/0144753	A1	6/2011	Marchek et al.
2011/0172716	A1	7/2011	Glerum
2011/0270261	A1	11/2011	Mast et al.
2011/0282453	A1	11/2011	Greenhalgh et al.
2011/0301711	A1	12/2011	Palmatier et al.
2011/0301712	A1	12/2011	Palmatier et al.
2012/0004726	A1	1/2012	Greenhalgh et al.
2012/0004732	A1	1/2012	Goel et al.
2012/0022654	A1	1/2012	Farris et al.
2012/0029636	A1	2/2012	Ragab et al.
2012/0071977	A1	3/2012	Oglaza et al.
2012/0071980	A1	3/2012	Purcell et al.
2012/0083889	A1	4/2012	Purcell et al.
2012/0123546	A1	5/2012	Medina
2012/0185049	A1	7/2012	Varela
2012/0197403	A1	8/2012	Merves
2012/0197405	A1	8/2012	Cuevas et al.
2012/0226357	A1	9/2012	Varela
2012/0232552	A1	9/2012	Morgenstern et al.
2012/0265309	A1	10/2012	Glerum et al.
2012/0290097	A1	11/2012	Cipoletti et al.
2012/0310350	A1	12/2012	Farris et al.
2012/0310352	A1	12/2012	DiMauro et al.
2013/0030536	A1	1/2013	Rhoda et al.
2013/0085572	A1	4/2013	Glerum et al.
2013/0085574	A1	4/2013	Sledge
2013/0116791	A1	5/2013	Theofilos
2013/0123924	A1	5/2013	Butler et al.
2013/0123927	A1	5/2013	Malandain
2013/0138214	A1	5/2013	Greenhalgh et al.
2013/0144387	A1	6/2013	Walker et al.
2013/0144388	A1	6/2013	Emery et al.
2013/0158663	A1	6/2013	Miller et al.
2013/0158664	A1	6/2013	Palmatier et al.
2013/0158667	A1	6/2013	Tabor et al.
2013/0158668	A1	6/2013	Nichols et al.
2013/0158669	A1	6/2013	Sungarian et al.
2013/0173004	A1	7/2013	Greenhalgh et al.
2013/0190876	A1	7/2013	Drochner et al.
2013/0190877	A1	7/2013	Medina
2013/0204371	A1	8/2013	McLuen et al.
2013/0211525	A1	8/2013	McLuen et al.
2013/0211526	A1	8/2013	Alheidt et al.
2013/0310939	A1	11/2013	Fabian et al.
2014/0039622	A1	2/2014	Glerum et al.
2014/0046333	A1	2/2014	Johnson et al.
2014/0058513	A1	2/2014	Gahman et al.
2014/0067073	A1	3/2014	Hauck
2014/0114423	A1	4/2014	Suedkamp et al.
2014/0128977	A1	5/2014	Glerum et al.
2014/0135934	A1	5/2014	Hansell et al.
2014/0142706	A1	5/2014	Hansell et al.
2014/0163683	A1	6/2014	Seifert et al.
2014/0172106	A1	6/2014	To et al.
2014/0180421	A1	6/2014	Glerum et al.
2014/0249629	A1	9/2014	Moskowitz et al.
2014/0249630	A1	9/2014	Weiman
2014/0257484	A1	9/2014	Flower et al.
2014/0257486	A1	9/2014	Alheidt
2014/0303731	A1	10/2014	Glerum et al.
2014/0303732	A1	10/2014	Rhoda et al.
2014/0324171	A1	10/2014	Glerum et al.
2015/0045894	A1	2/2015	Hawkins et al.

(56)

References Cited

U.S. PATENT DOCUMENTS

2015/0094812 A1 4/2015 Marden et al.  
 2015/0094813 A1 4/2015 Lechmann et al.  
 2015/0157470 A1 6/2015 Voellmicke et al.  
 2015/0173916 A1 6/2015 Cain et al.  
 2015/0216671 A1 8/2015 Cain et al.  
 2015/0216672 A1 8/2015 Cain et al.  
 2016/0317317 A1 3/2016 Marchek et al.

FOREIGN PATENT DOCUMENTS

DE 3911610 10/1990  
 DE 4012622 7/1997  
 DE 202008001079 3/2008  
 EP 282161 9/1988  
 EP 678489 10/1995  
 EP 1290985 3/2003  
 EP 1532949 5/2005  
 EP 1541096 6/2005  
 EP 1683593 7/2006  
 EP 1698305 B1 8/2007  
 EP 1843723 B1 3/2010  
 EP 2368529 9/2011  
 EP 2237748 B1 9/2012  
 EP 2764851 8/2014  
 FR 2718635 10/1995  
 FR 2730159 8/1996  
 FR 2874814 3/2006  
 JP 2003-526457 9/2003  
 JP 2006-516456 7/2006  
 JP 2011-509766 A 3/2011  
 WO WO 1994/004100 3/1994  
 WO WO 1995/031158 11/1995  
 WO WO 97/00054 1/1997  
 WO WO 1999/053871 10/1999  
 WO WO 2000/012033 3/2000  
 WO WO 2000/074605 12/2000  
 WO WO 01/01895 1/2001  
 WO WO 2000/53127 1/2001  
 WO WO 2001001893 1/2001  
 WO WO 2001/017464 3/2001  
 WO WO 2005/112834 12/2005  
 WO WO 2006/047587 5/2006  
 WO WO 2006/058281 6/2006  
 WO WO 2006/065419 6/2006  
 WO WO 2006/081843 8/2006  
 WO WO 2007/028098 3/2007  
 WO WO 2007/048012 4/2007  
 WO WO 2008/044057 4/2008  
 WO WO 2007/009107 8/2008

WO WO 2009/092102 7/2009  
 WO WO 2009/064787 8/2009  
 WO WO 2009/124269 10/2009  
 WO WO 2009/143496 11/2009  
 WO WO 2010/068725 6/2010  
 WO WO 2010/148112 12/2010  
 WO WO 2011/142761 11/2011  
 WO WO 2012/009152 1/2012  
 WO WO 2012/089317 7/2012  
 WO WO 2012/135764 10/2012  
 WO WO 2013/006669 1/2013  
 WO WO 2013/023096 2/2013  
 WO WO 2013/025876 2/2013  
 WO WO 2013/043850 5/2013  
 WO WO 2013/062903 5/2013  
 WO WO 2013/082184 6/2013  
 WO WO 2013/158294 10/2013  
 WO WO 2013/173767 11/2013  
 WO WO 2013/184946 12/2013  
 WO WO 2014/018098 1/2014  
 WO WO 2014/026007 2/2014  
 WO WO 2014/035962 3/2014  
 WO WO 2014/088521 6/2014  
 WO WO 2014/116891 7/2014  
 WO WO 2014/144696 9/2014

OTHER PUBLICATIONS

Folman, Posterior Lumbar Interbody Fusion for Degenerative Disc Disease Using a Minimally Invasive B-Twin Expandable Spinal Spacer, *Journal of Spinal Disorders & Techniques*, 2003, pp. 455-460, vol. 16(5).  
 Gore, Technique of Cervical Interbody Fusion, *Clinical Orthopaedics and Related Research*, 1984, pp. 191-195, No. 188.  
 Hunt, Expanable cage placement via a posterolateral approach in lumbar spine reconstructions, *Journal of Neurosurgery: Spine*, 2006, pp. 271-274, vol. 5.  
 Krbec, [Replacement of the vertebral body with an expansion implant (Synex)], *Acta Chir Orthop Traumatol Cech*, 2002, pp. 158-162, vol. 69(3).  
 Polikeit, The importance of the endplate for interbody cages in the lumbar spine, *Eur Spine J*, 2003, pp. 556-561, vol. 12.  
 Shin, Posterior Lumbar Interbody Fusion via a Unilateral Approach, *Yonsei Medical Journal*, 2006, pp. 319-325, vol. 47(3).  
 Hoogland, T. et al., Total Lumbar Intervertebral Disc Replacement: testing of a New Articulating Space in Human Cadaver Spines—24 1 Annual ORS, Dallas TX, Feb. 21-23, 1978, 8 pages.  
*Spine Solutions Brochure*—Prodisc 2001, 16 pages.  
 Link SB Charite Brochure—Intervertebral Prosthesis 1988, 29 pages.

\* cited by examiner



FIG. 2

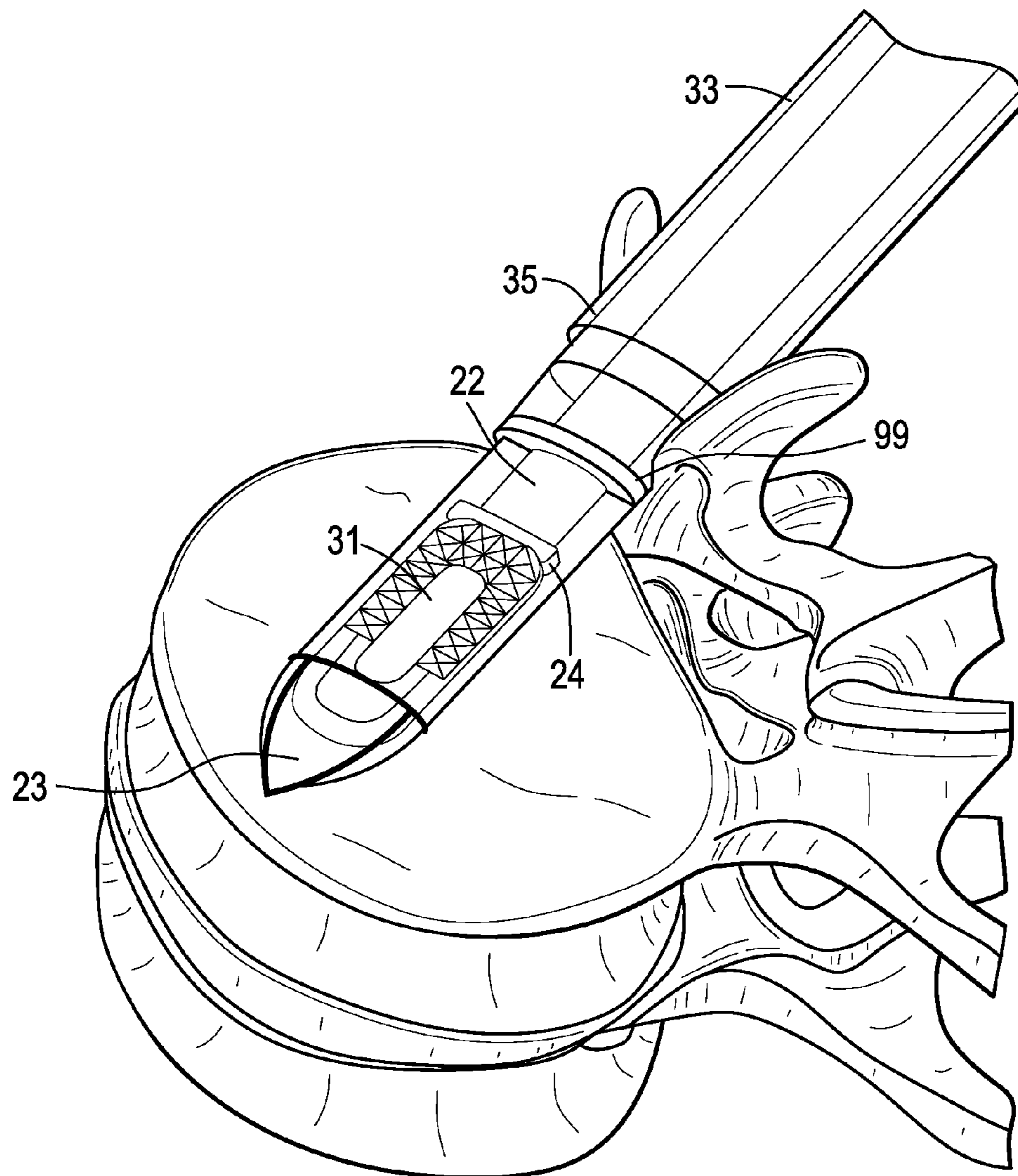

FIG. 3A

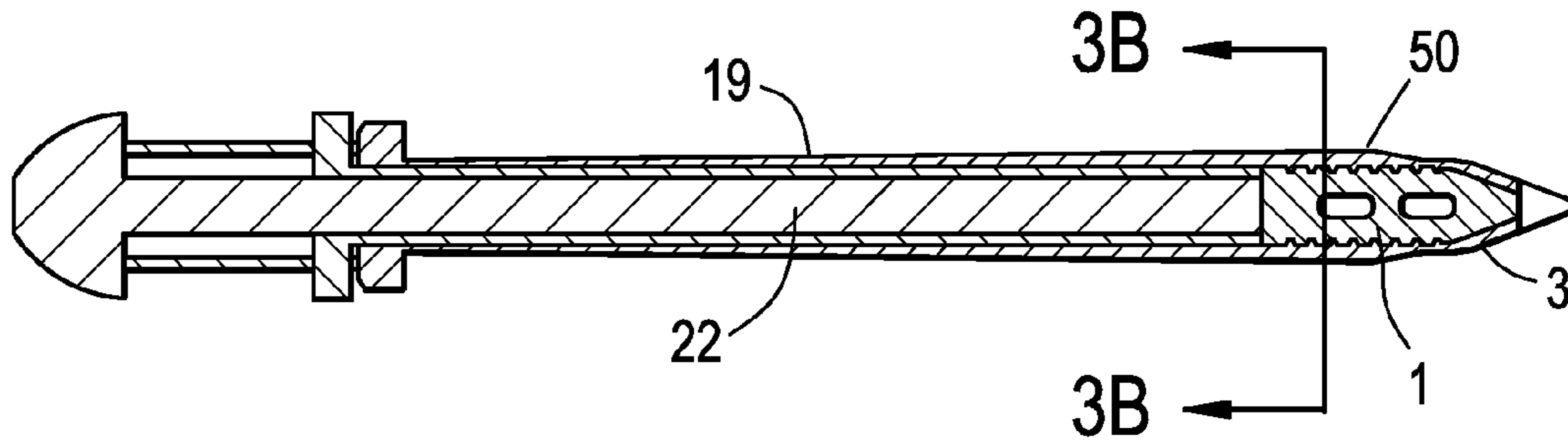

FIG. 3B

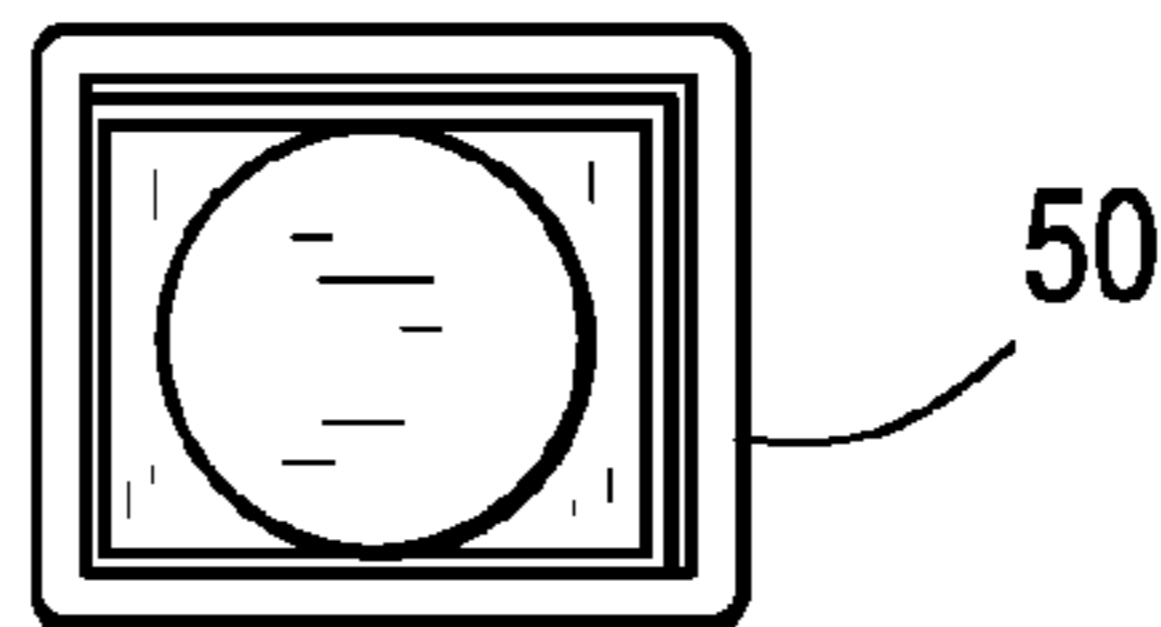

FIG. 3C

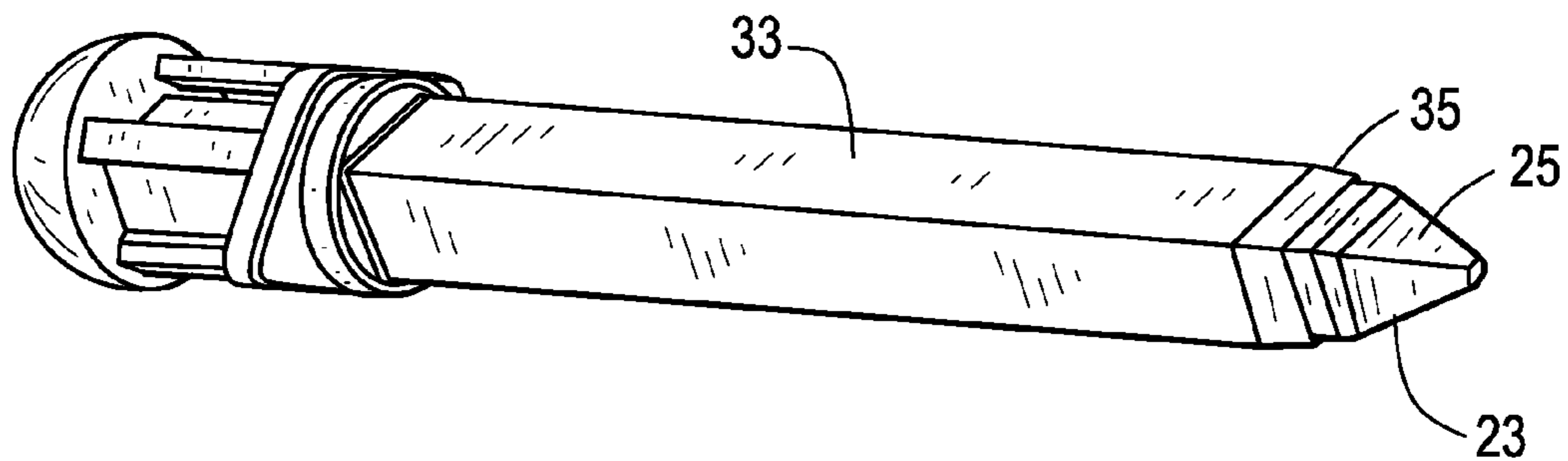

FIG. 3D

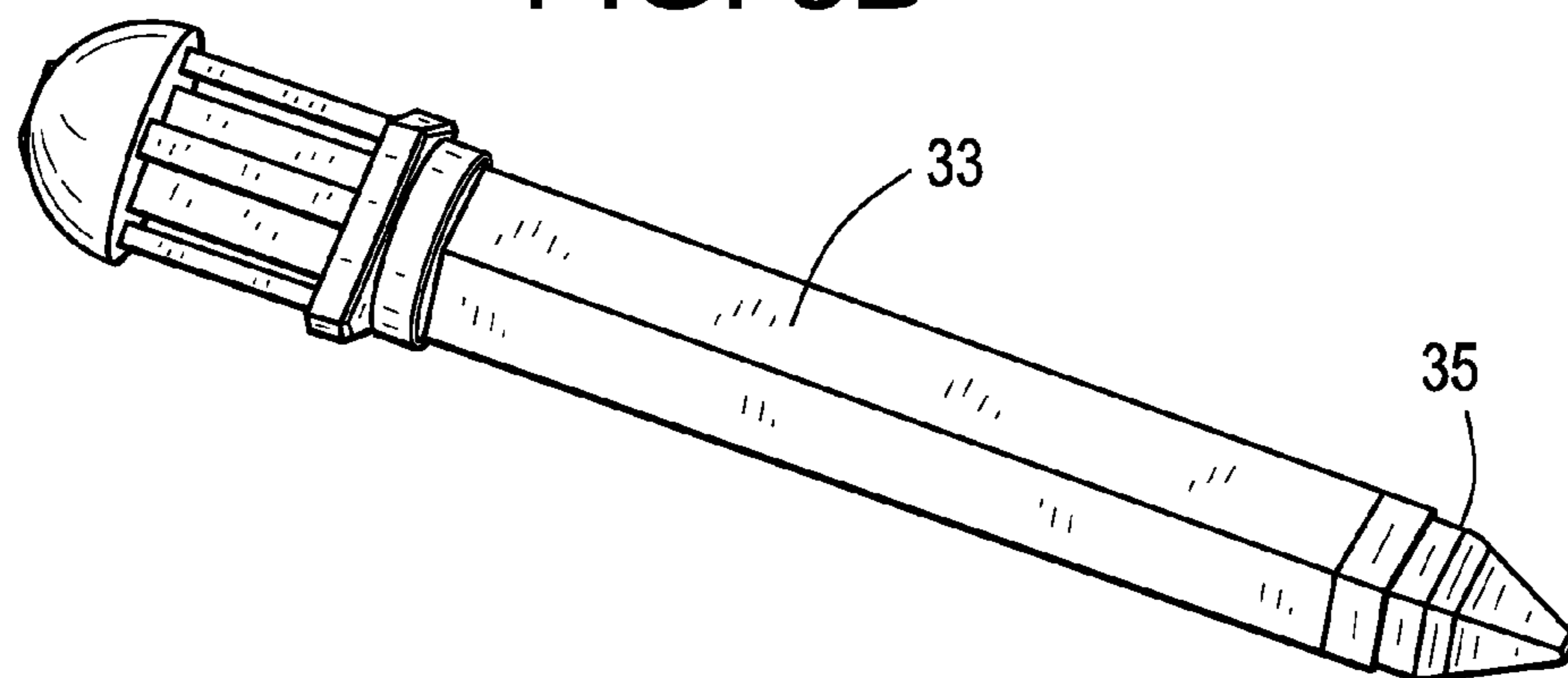



FIG. 4A

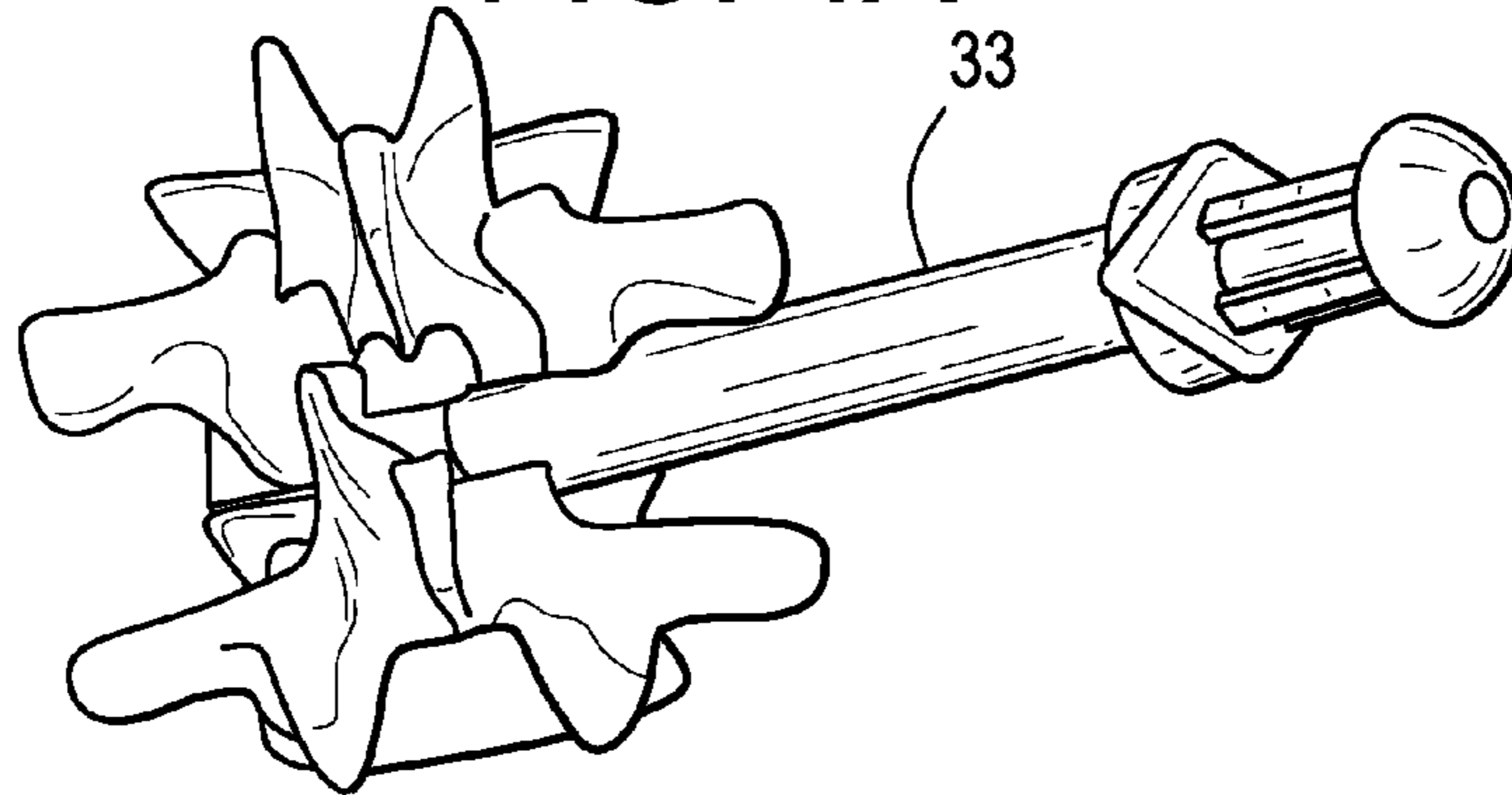

FIG. 4B

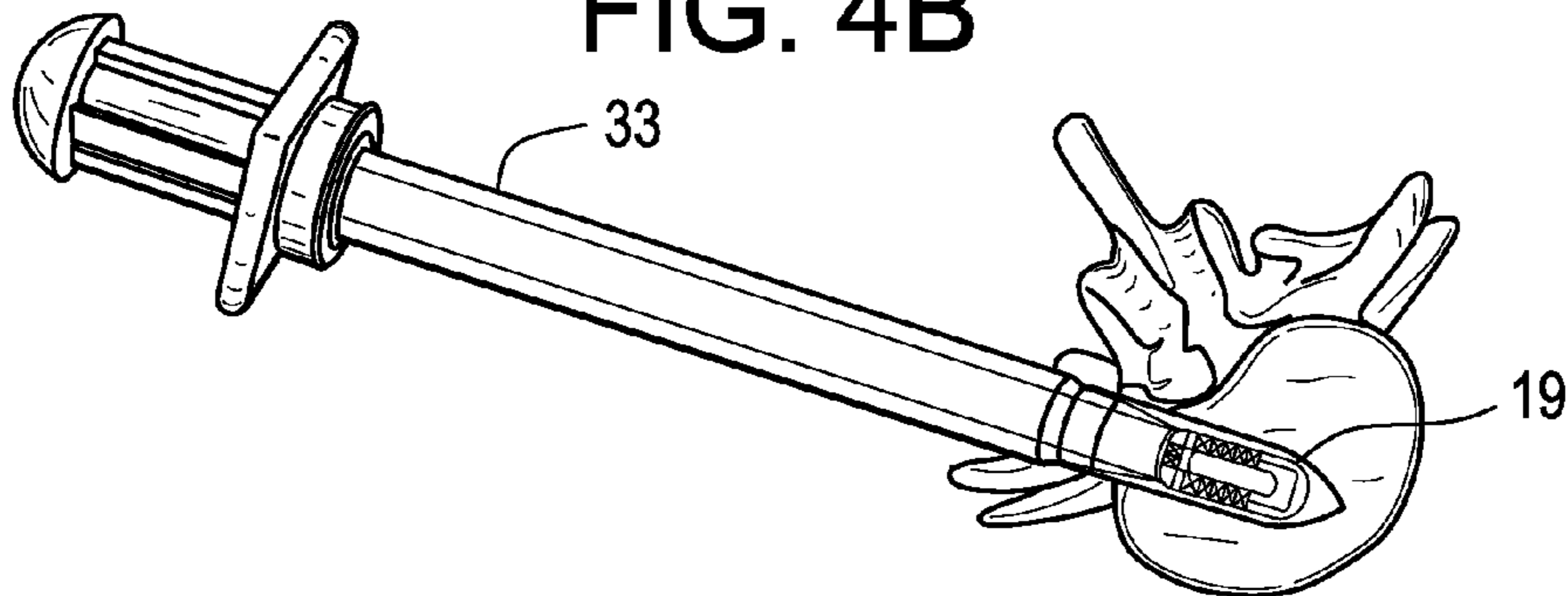

FIG. 4C

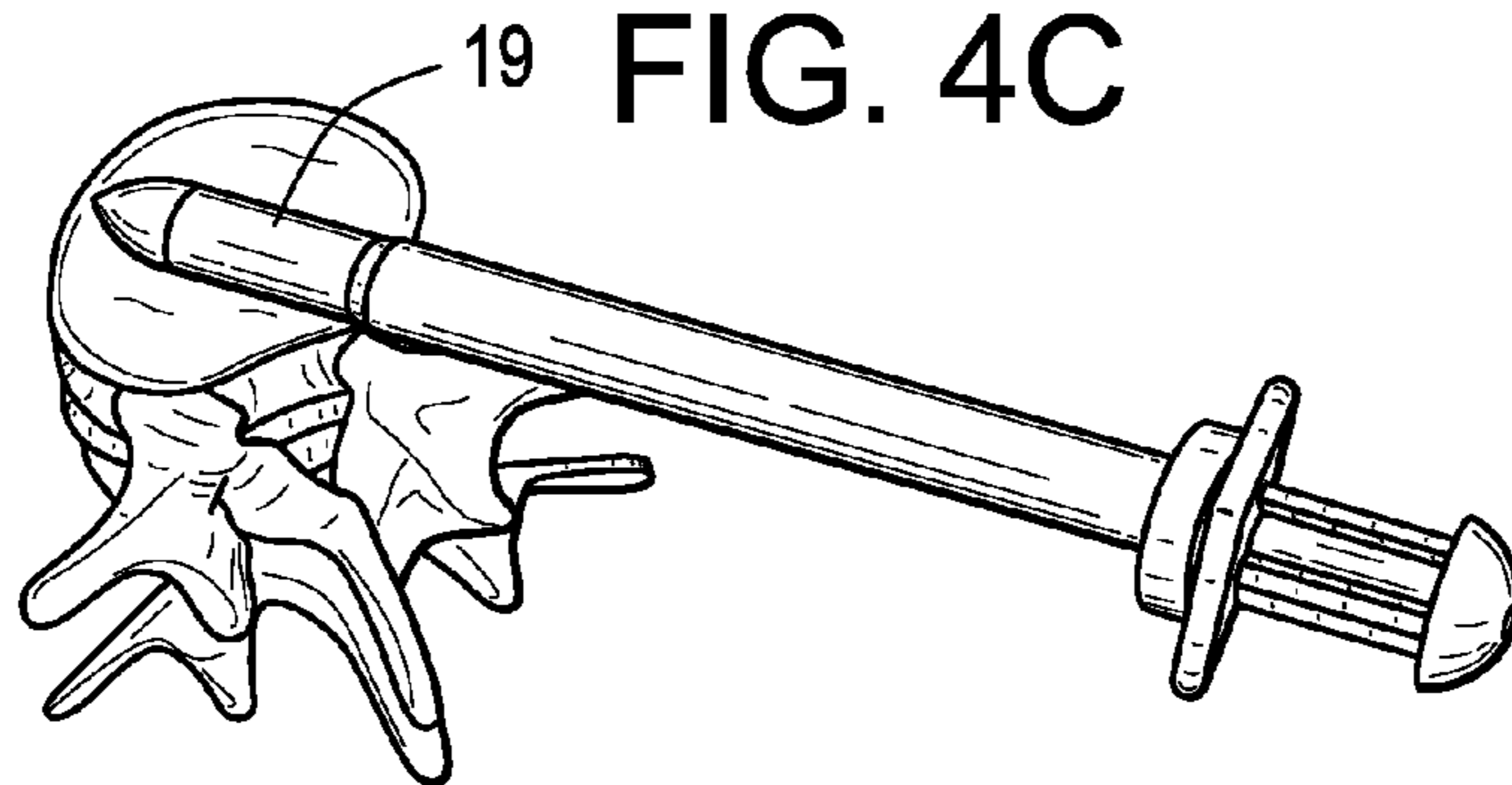

FIG. 4D

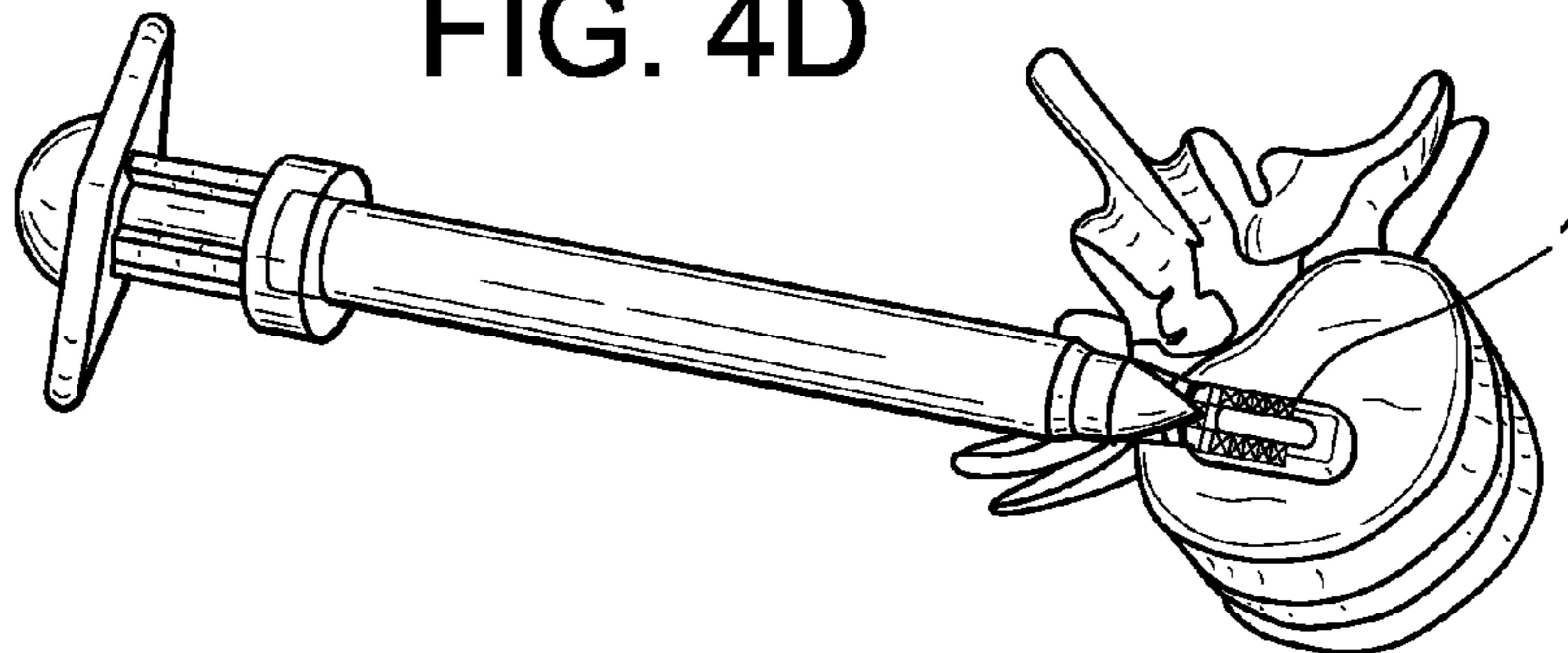

FIG. 5

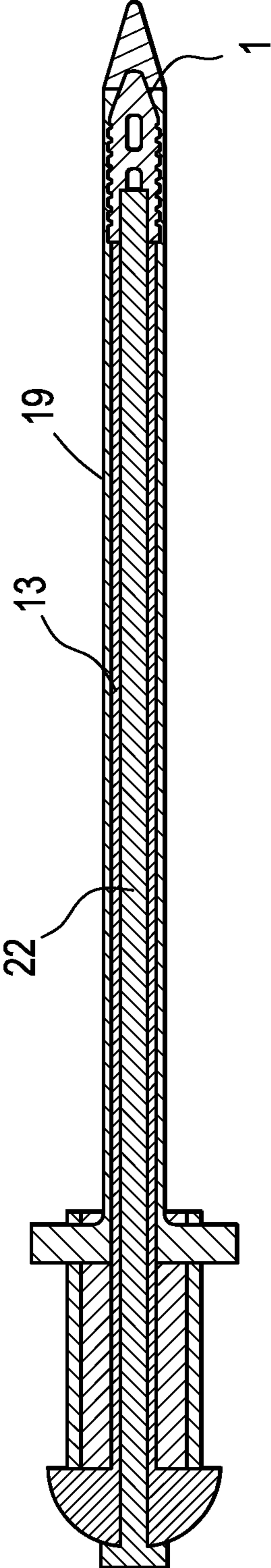

FIG. 6A

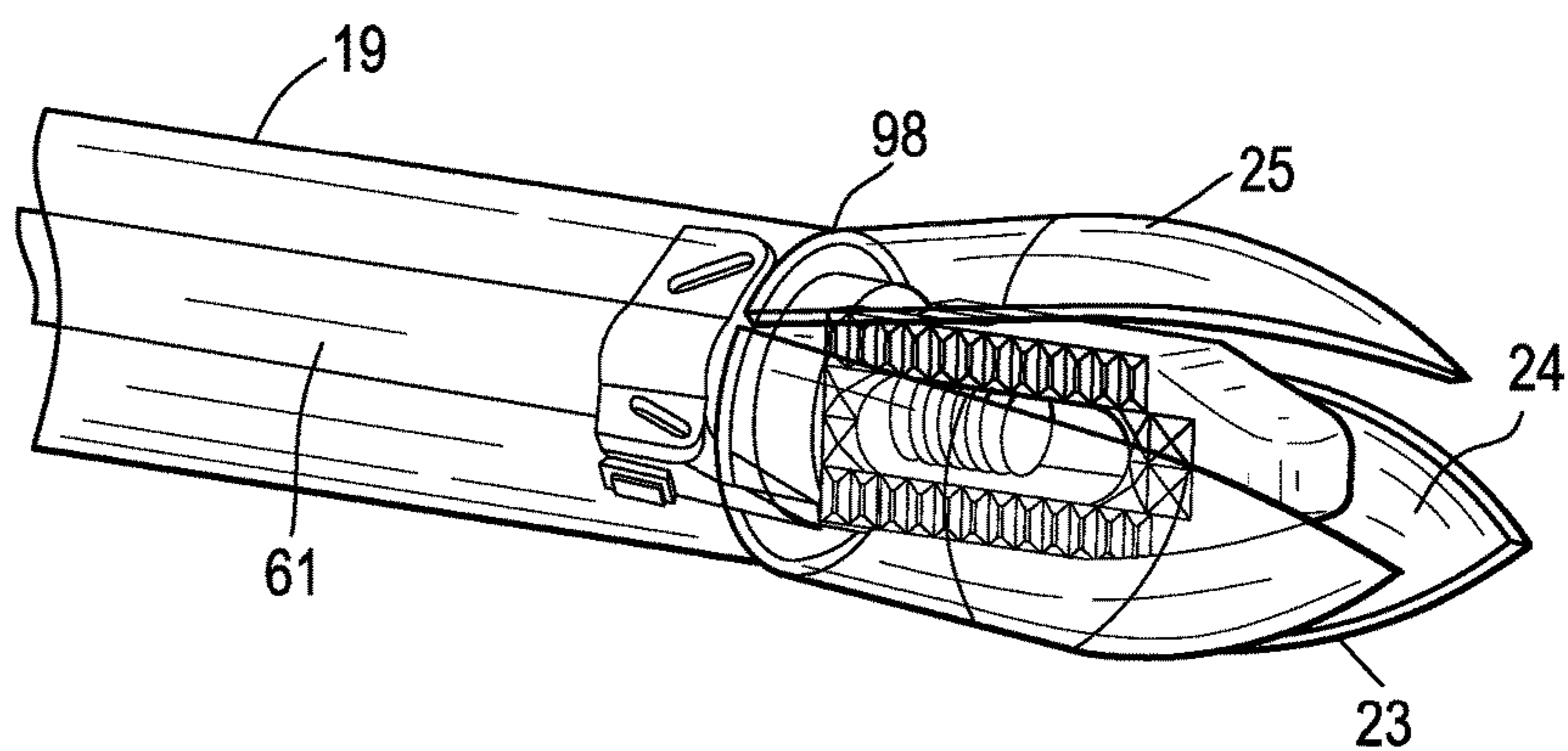

FIG. 6B

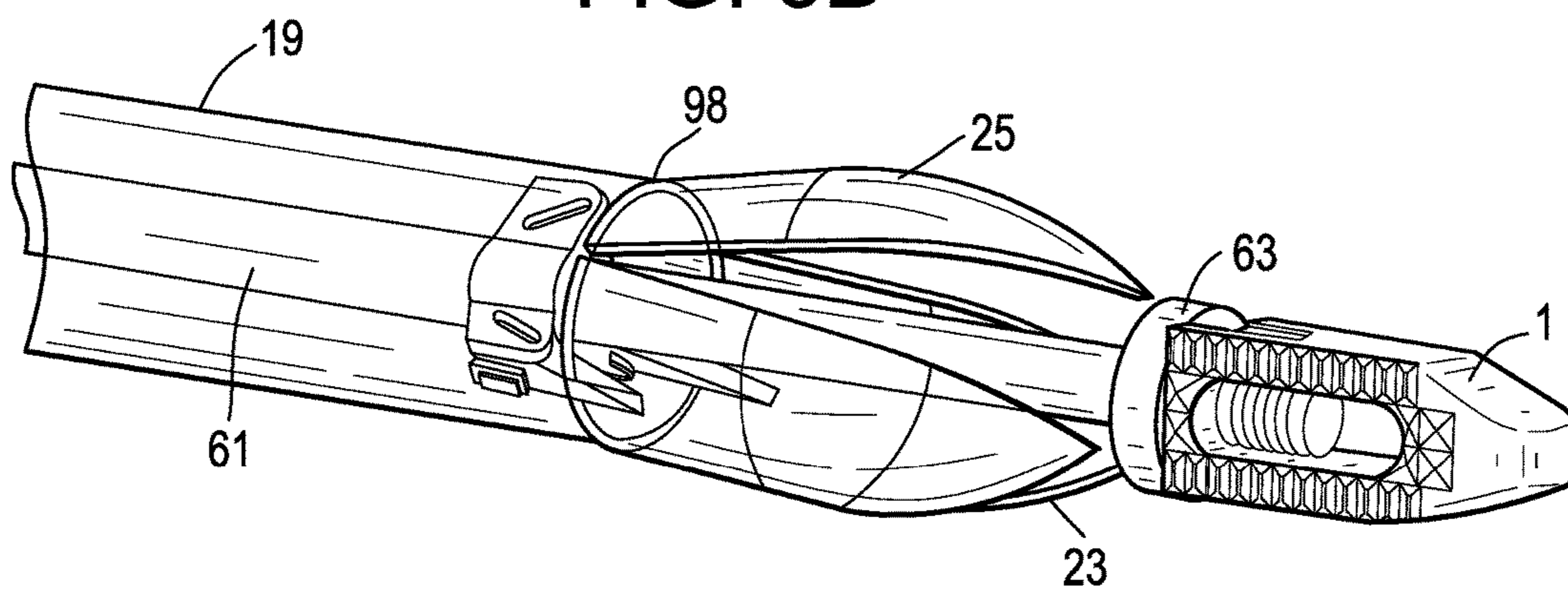

FIG. 7A

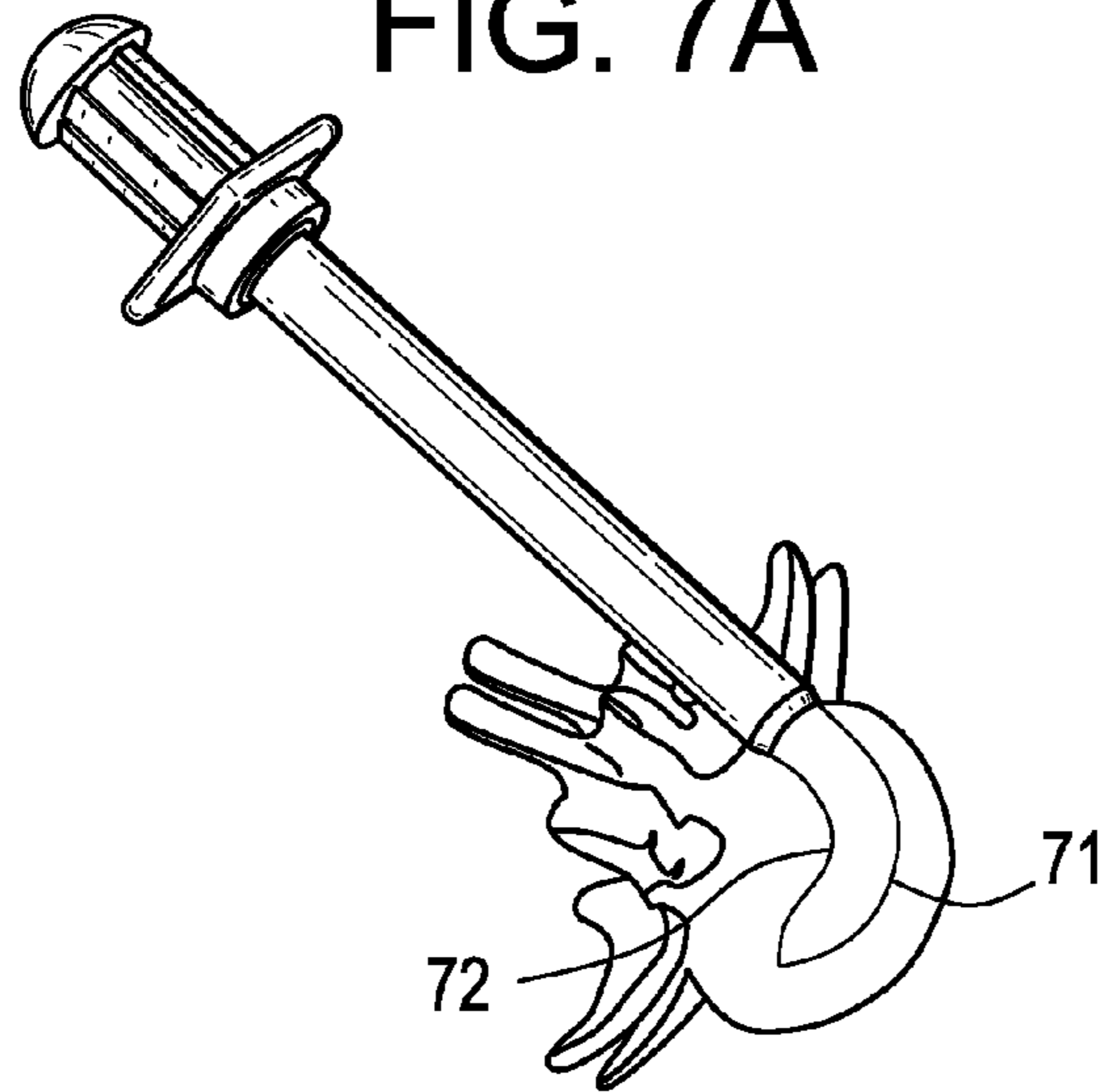

FIG. 7B

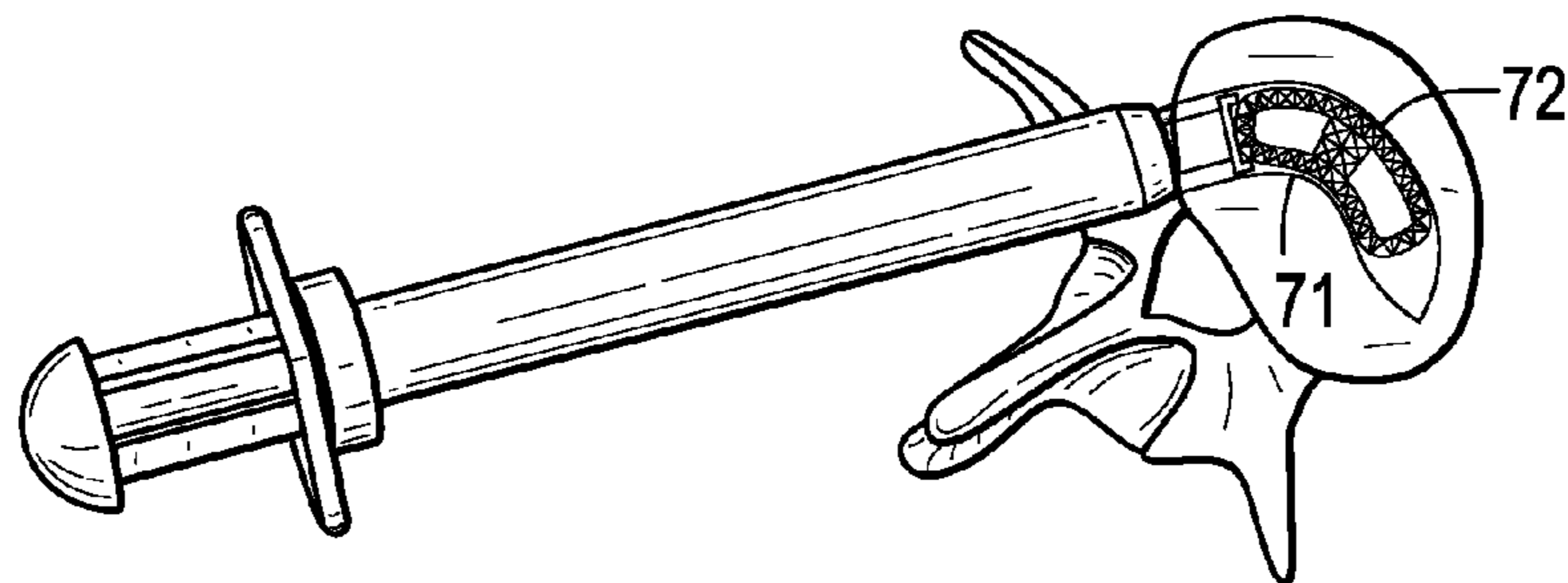

FIG. 7C

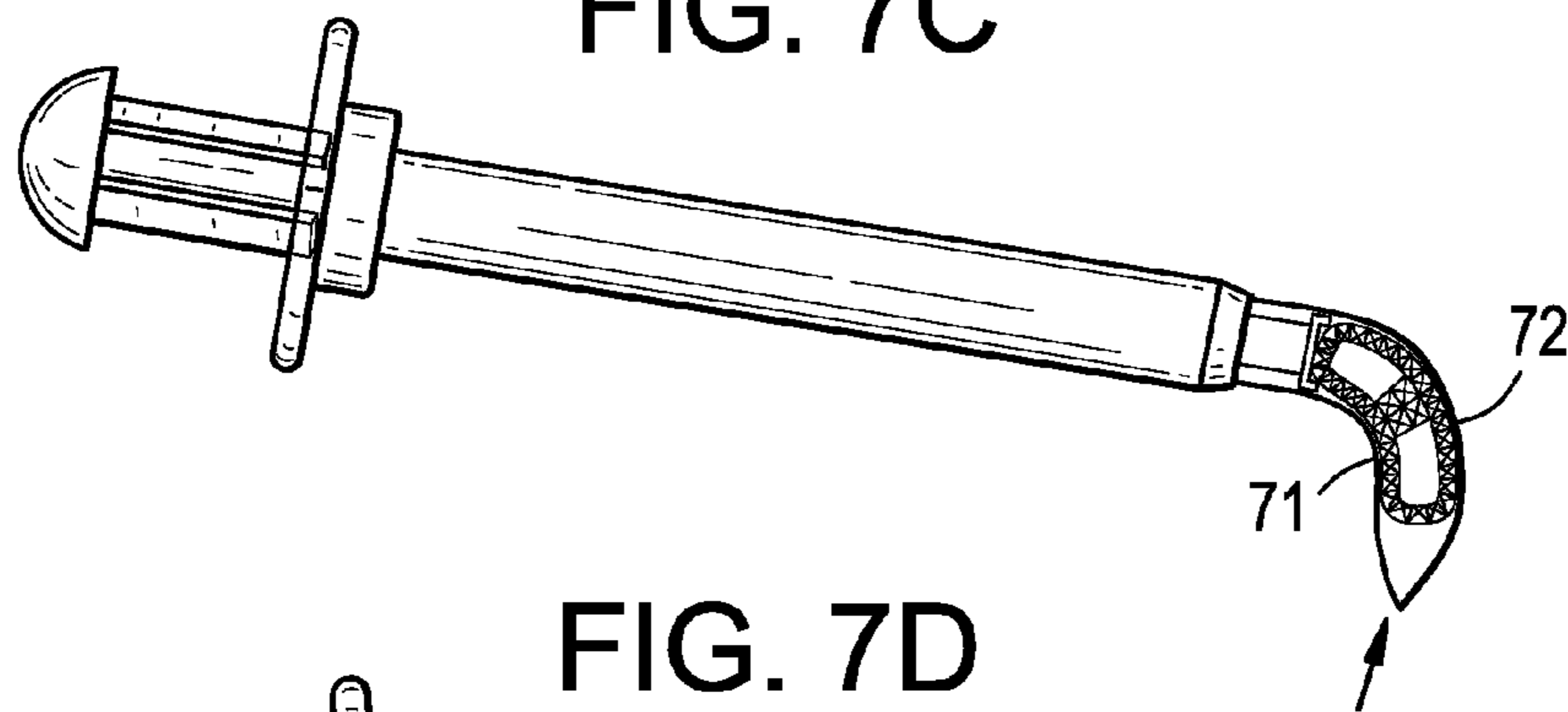

FIG. 7D

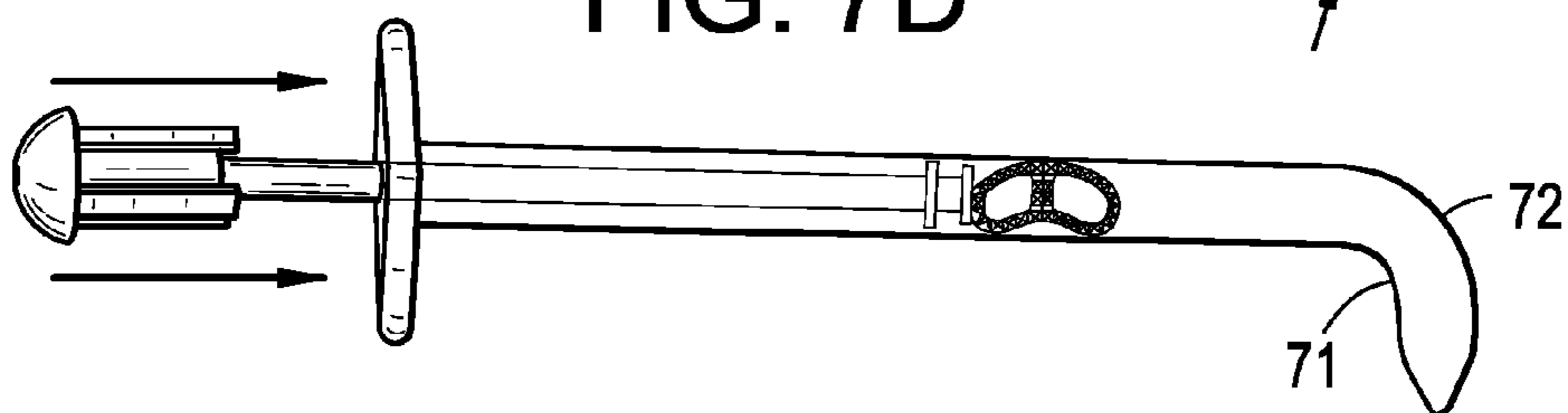

FIG. 8A

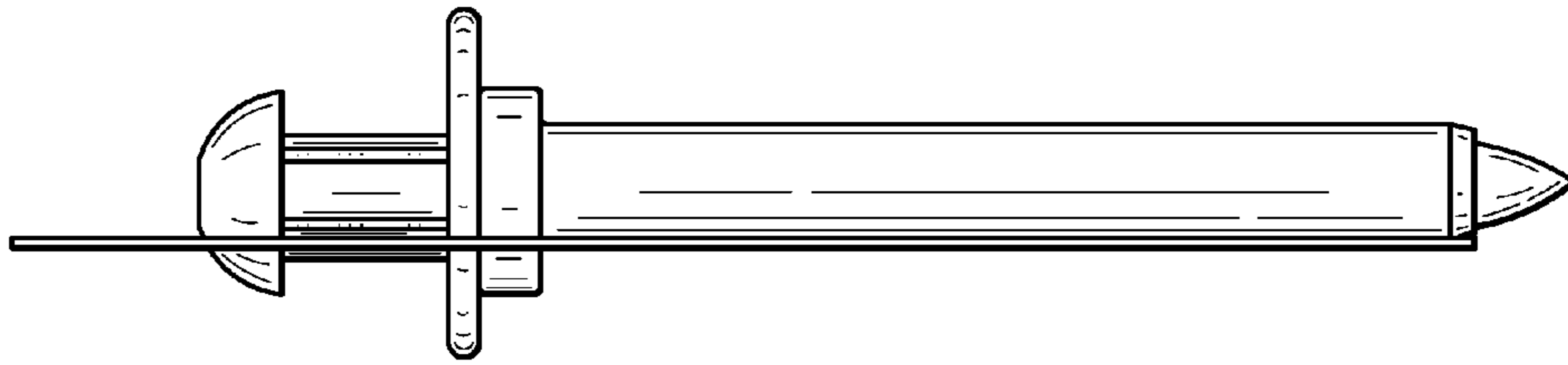

FIG. 8B

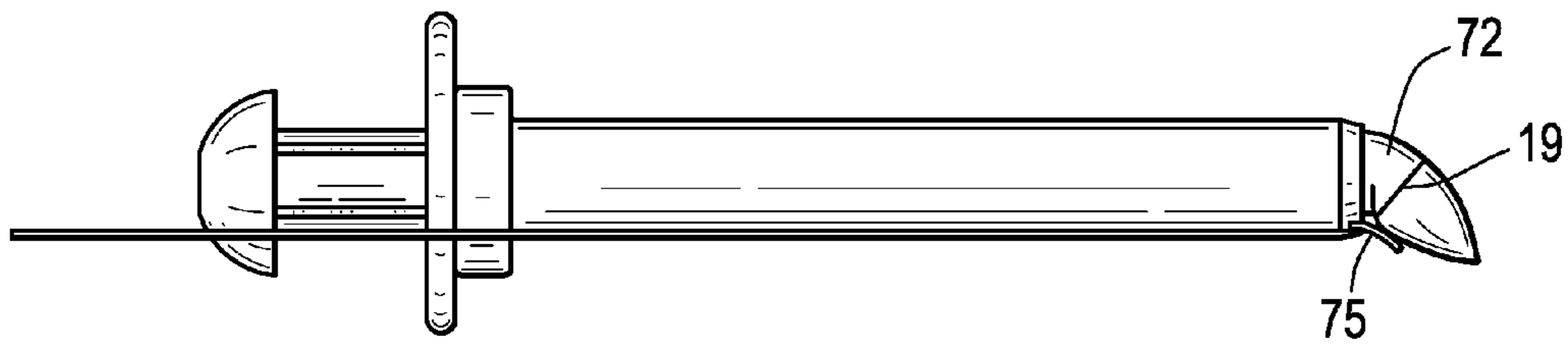

FIG. 8C



FIG. 8D

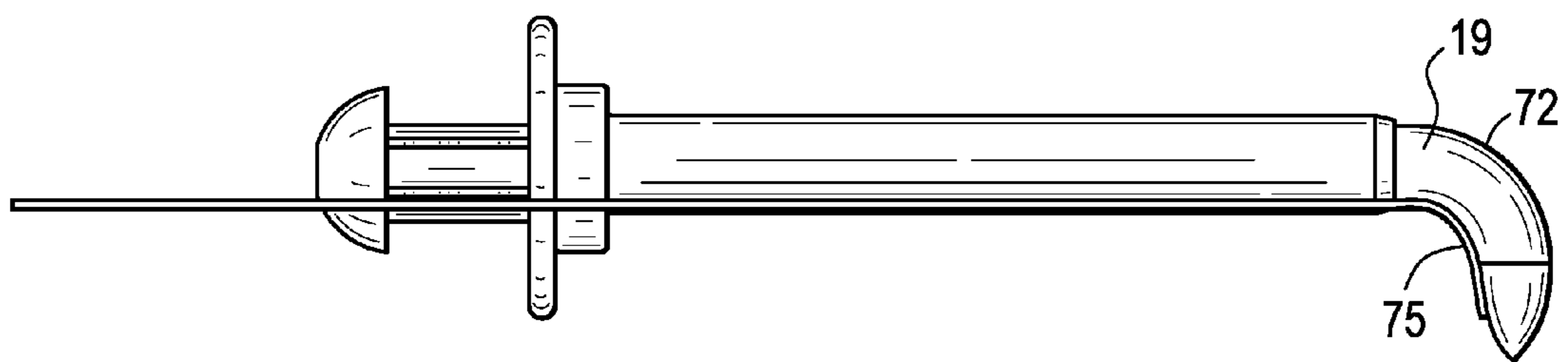

FIG. 9

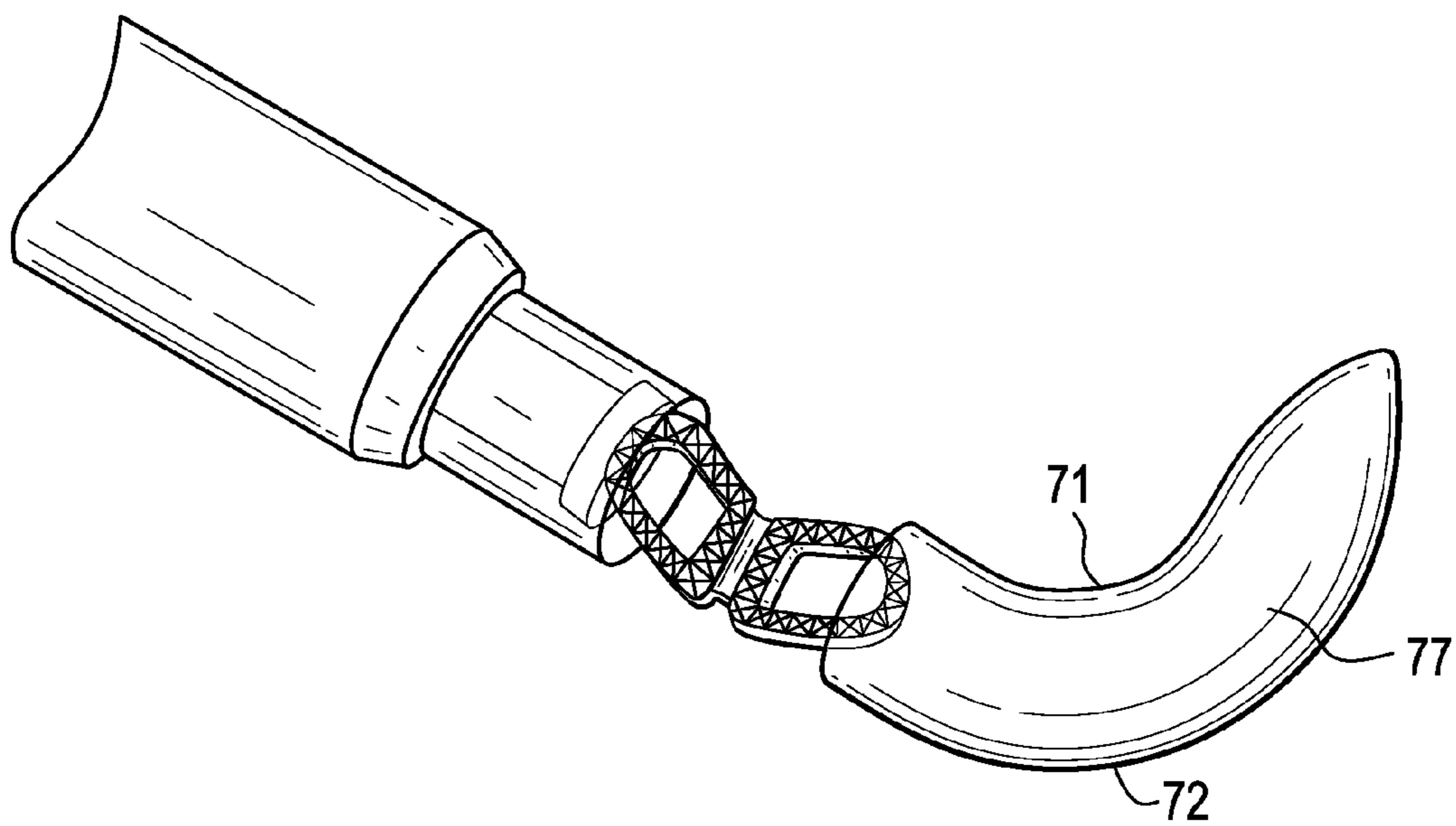

FIG. 10A

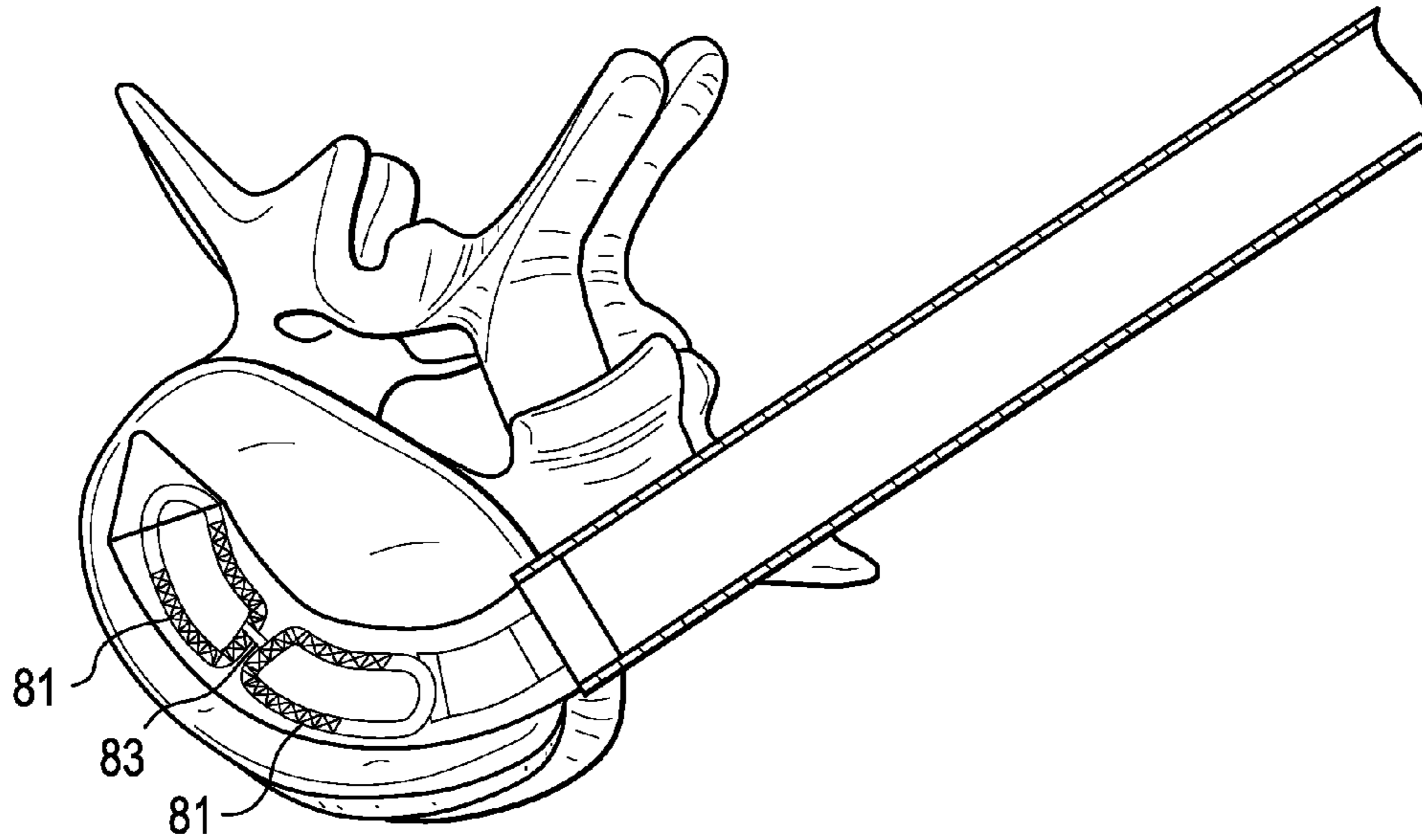

FIG. 10B

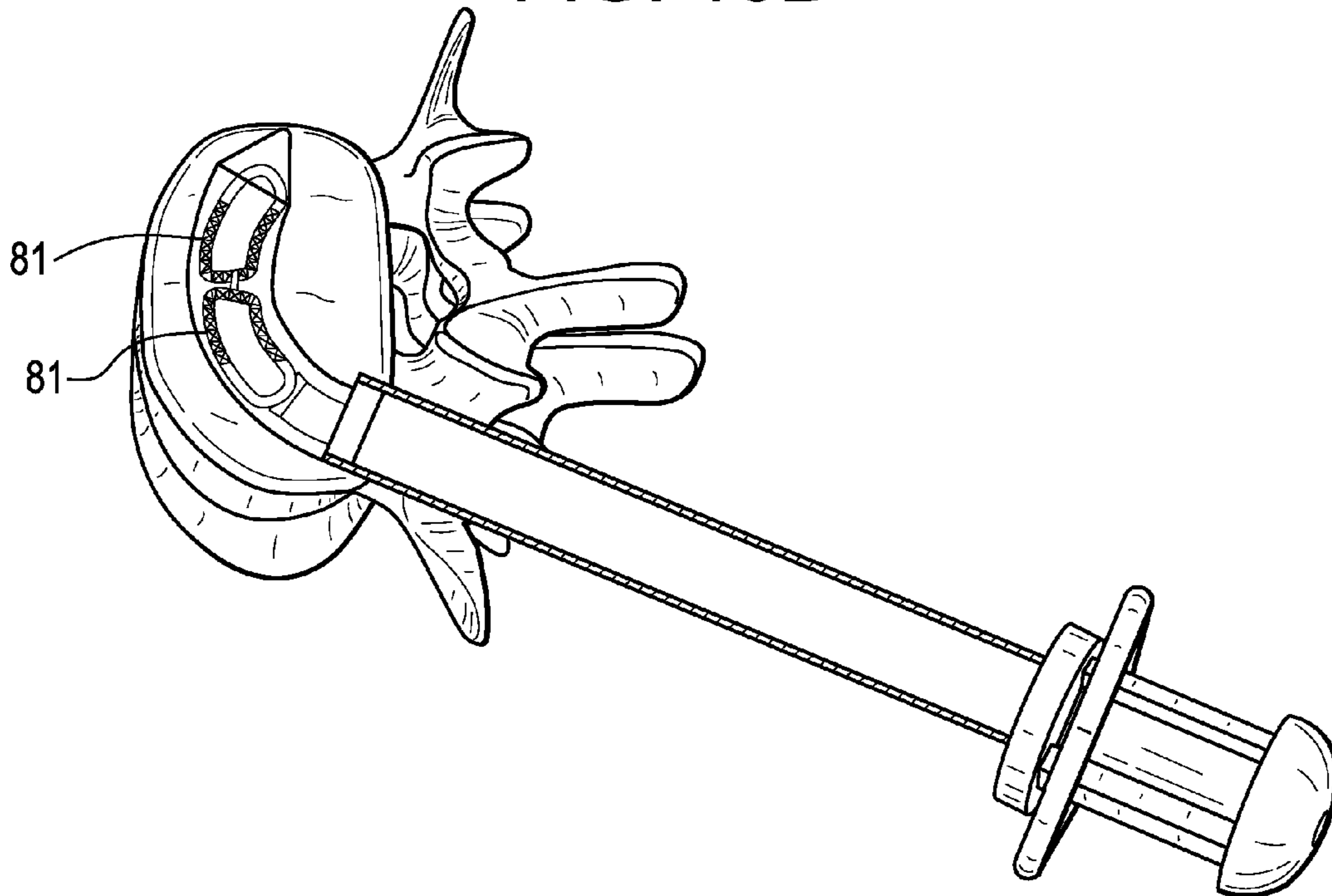

FIG. 11A

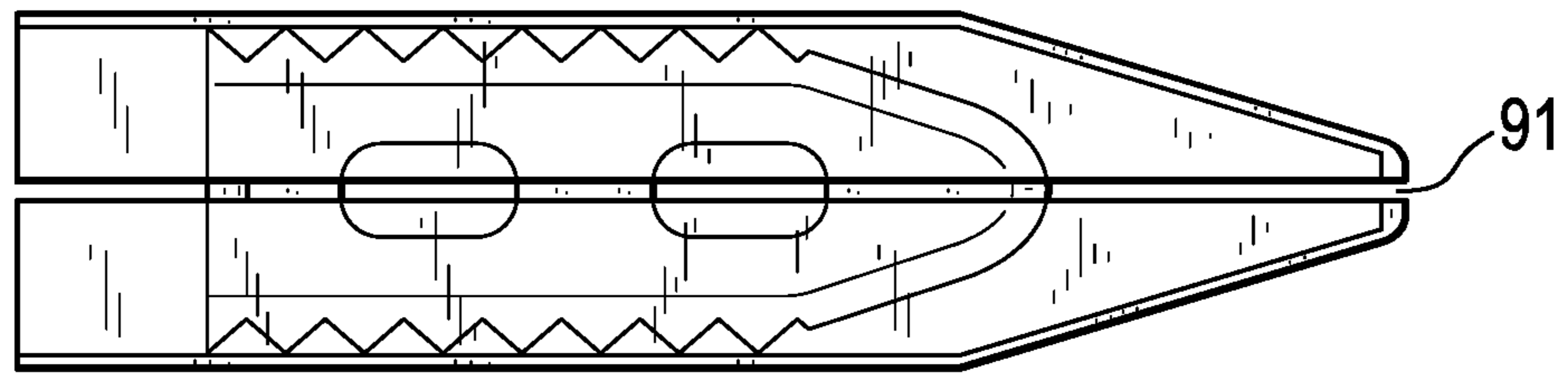

FIG. 11B

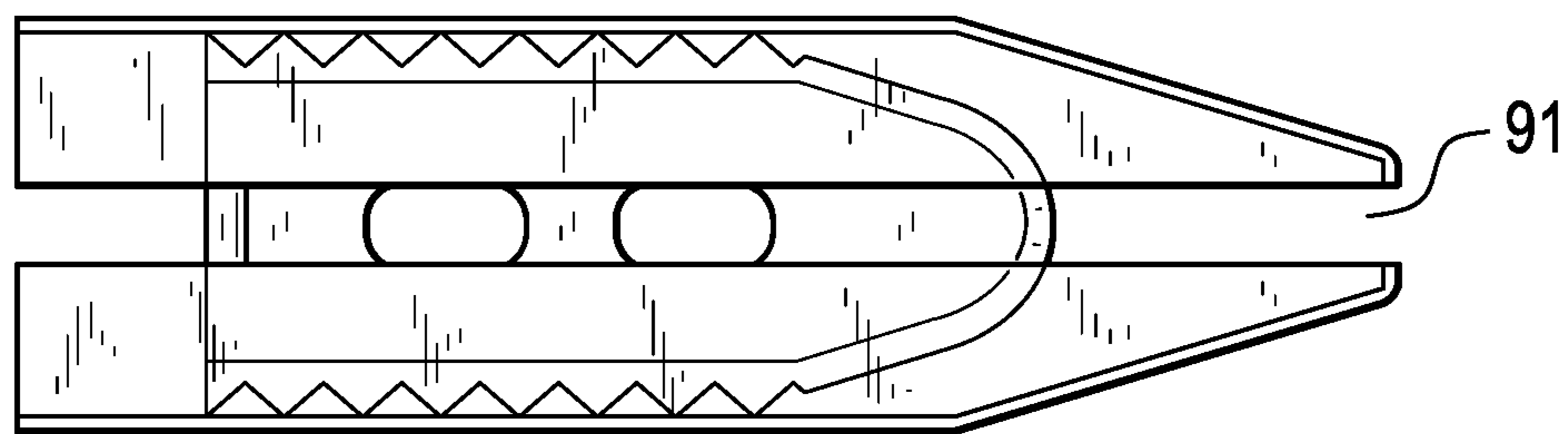

FIG. 11C

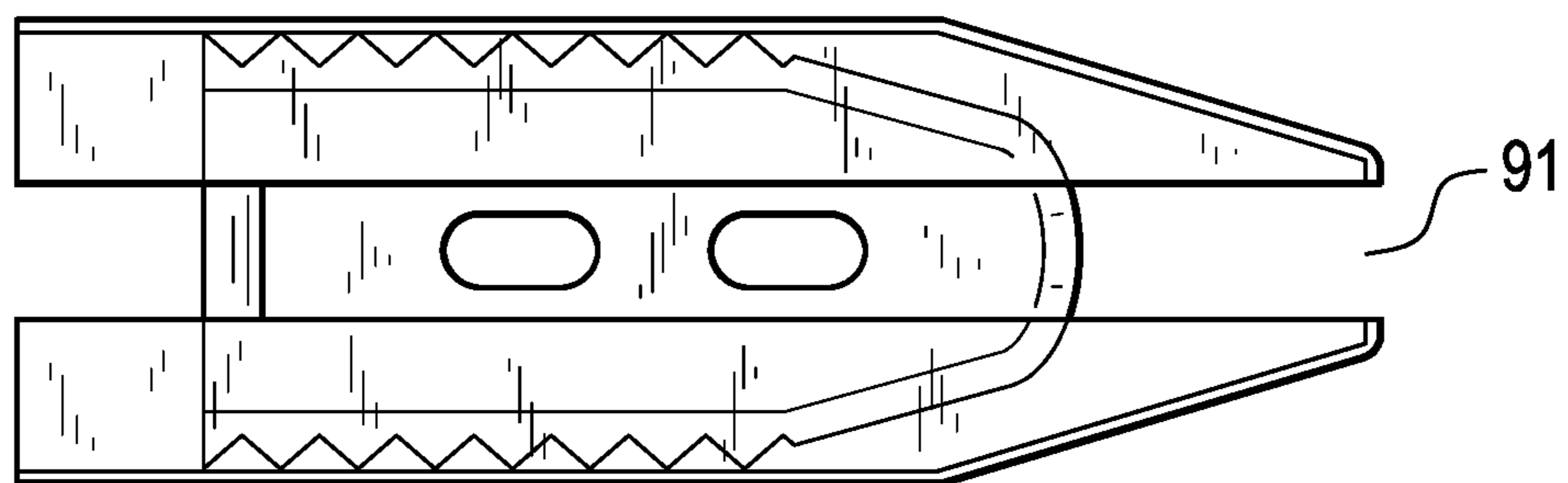



FIG. 12A

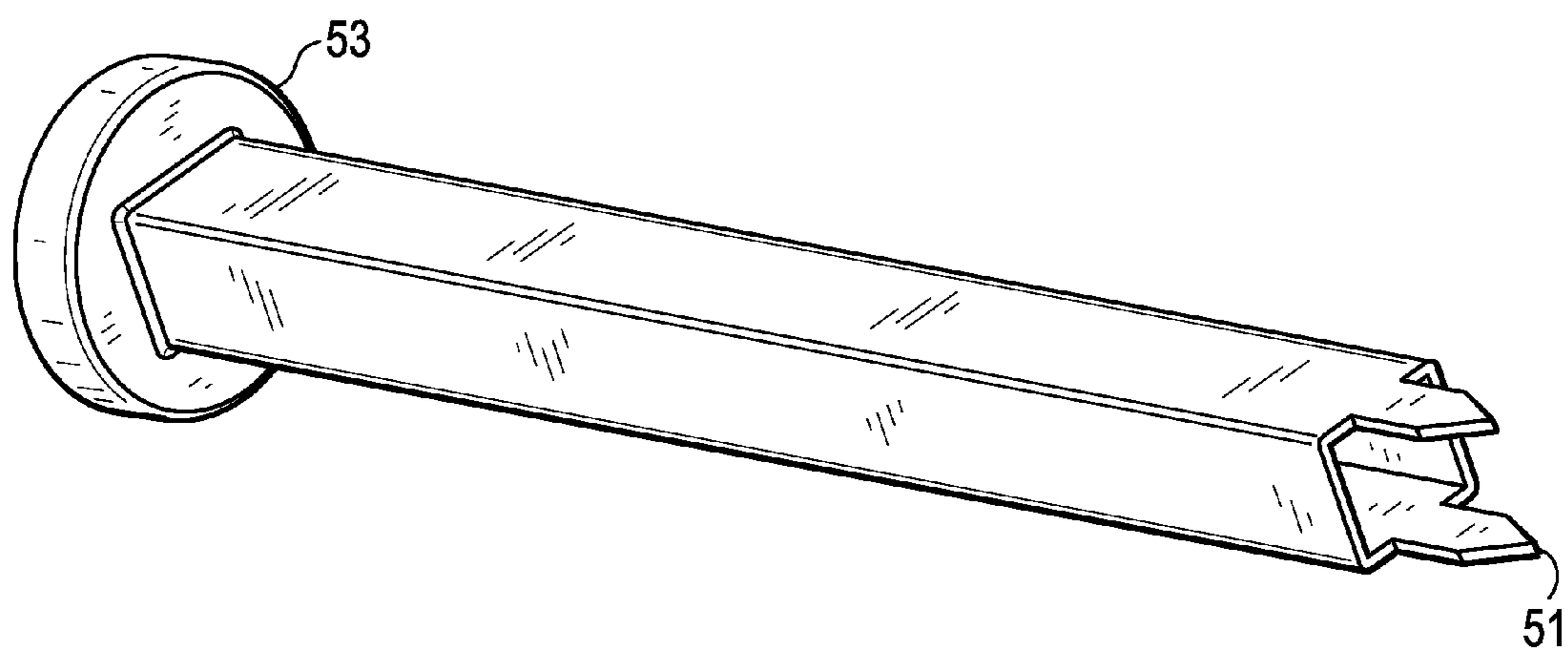
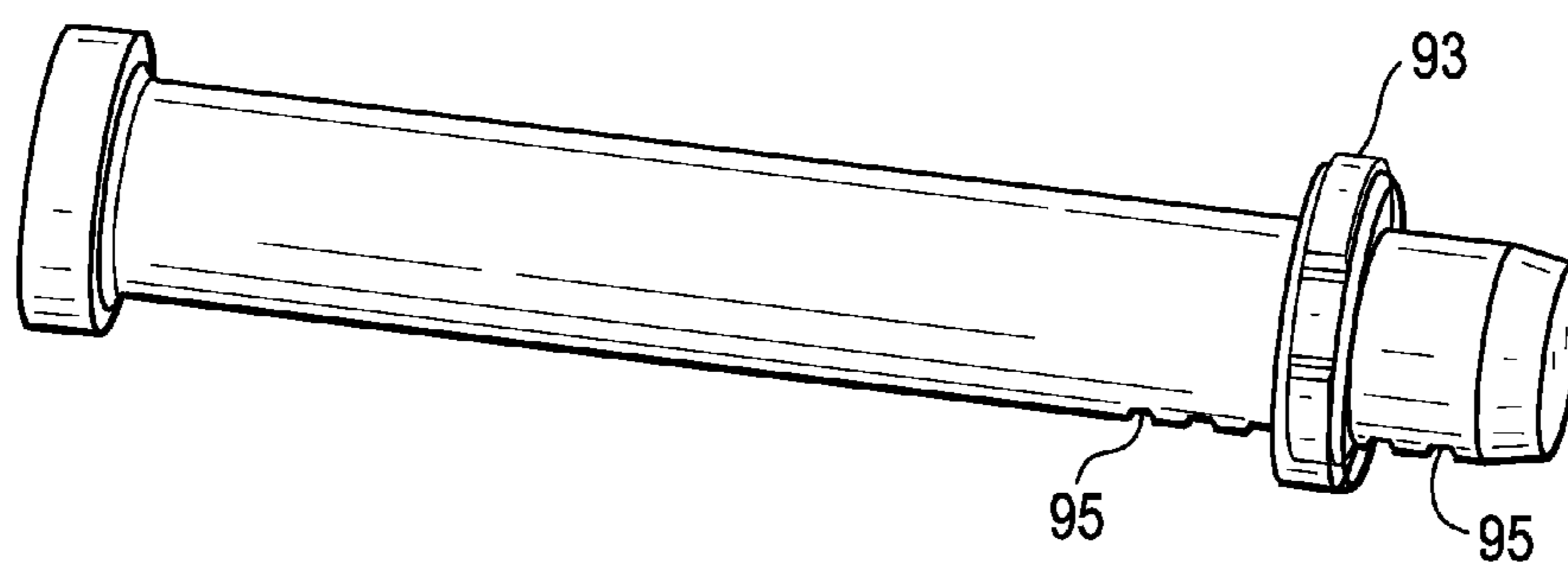

FIG. 12B



**ENHANCED CAGE INSERTION ASSEMBLY**

## CONTINUING DATA

This application is a continuation of and claims priority from U.S. Ser. No. 14/623,982, filed Feb. 17, 2015, entitled “Enhanced Cage Insertion Device” (Voellmicke) (DEP6325USCNT1), and from U.S. Ser. No. 12/822,739, filed Jun. 24, 2010, now U.S. Pat. No. 8,979,860, entitled “Enhanced Cage Insertion Device” (Voellmicke) (DEP6325USNP), the specifications of which are incorporated by reference in their entirety.

## BACKGROUND OF THE INVENTION

The natural intervertebral disc contains a jelly-like nucleus pulposus surrounded by a fibrous annulus fibrosus. Under an axial load, the nucleus pulposus compresses and radially transfers that load to the annulus fibrosus. The laminated nature of the annulus fibrosus provides it with a high tensile strength and so allows it to expand radially in response to this transferred load.

In a healthy intervertebral disc, cells within the nucleus pulposus produce an extracellular matrix (ECM) containing a high percentage of proteoglycans. These proteoglycans contain sulfated functional groups that retain water, thereby providing the nucleus pulposus with its cushioning qualities. These nucleus pulposus cells may also secrete small amounts of cytokines as well as matrix metalloproteinases (MMPs). These cytokines and MMPs help regulate the metabolism of the nucleus pulposus cells.

In some instances of degenerative disc disease (DDD), gradual degeneration of the intervertebral disc is caused by mechanical instabilities in other portions of the spine. In these instances, increased loads and pressures on the nucleus pulposus cause the cells within the disc (or invading macrophages) to emit larger than normal amounts of the above-mentioned cytokines. In other instances of DDD, genetic factors or apoptosis can also cause the cells within the nucleus pulposus to emit toxic amounts of these cytokines and MMPs. In some instances, the pumping action of the disc may malfunction (due to, for example, a decrease in the proteoglycan concentration within the nucleus pulposus), thereby retarding the flow of nutrients into the disc as well as the flow of waste products out of the disc. This reduced capacity to eliminate waste may result in the accumulation of high levels of proinflammatory cytokines and/or MMPs that may cause nerve irritation and pain.

As DDD progresses, toxic levels of the cytokines and MMPs present in the nucleus pulposus begin to degrade the extracellular matrix. In particular, the MMPs (as mediated by the cytokines) begin cleaving the water-retaining portions of the proteoglycans, thereby reducing their water-retaining capabilities. This degradation leads to a less flexible nucleus pulposus, and so changes the loading pattern within the disc, thereby possibly causing delamination of the annulus fibrosus. These changes cause more mechanical instability, thereby causing the cells to emit even more cytokines, typically thereby upregulating MMPs. As this destructive cascade continues and DDD further progresses, the disc begins to bulge (“a herniated disc”), and then ultimately ruptures, causing the nucleus pulposus to contact the spinal cord and produce pain.

One proposed method of managing these problems is to remove the problematic disc and replace it with a porous device that restores disc height and allows for bone growth

therethrough for the fusion of the adjacent vertebrae. These devices are commonly called “fusion devices”.

Designs of intervertebral fusion devices are generally either box-like (i.e., Smith-Robinson style) or threaded cylinders (i.e., Cloward style). Smith-Robinson style implants have the advantage of possessing better contact area to the vertebral endplates, but rely on a coarse surface texture (such as teeth) to prevent their migration once implanted. Insertion then requires over distraction of the disc space to slide the implant in or to provide a smoother implant, which can migrate post-op.

One such box-like design is the Brantigan cage, which is disclosed in U.S. Pat. No. 4,743,256 (“Brantigan”). Brantigan discloses an improved surgical method for eliminating spinal back pain caused by ruptured or degenerated vertebral discs by spanning the disc space between adjacent vertebrae with rigid fusion devices, or “cages”, having surfaces facilitating bone ingrowth and bottomed on prepared sites of the vertebrae to integrate the implant with the vertebrae and to provide a permanent weight supporting strut maintaining the disc space.

One commercial box-like design is the injection-molded carbon fiber reinforced PEEK (CFRP) cage made by DePuy Spine. However, these cages are difficult to insert because of the interference fit that is required for intervertebral space distraction. In addition, the reinforced PEEK material that makes up the teeth is brittle and so is susceptible to breakage when applying impact or torque loads to the implant.

Current interbody devices are made from single materials (e.g., machined titanium, or molded and/or machined PEEK). Titanium has the disadvantage of being radiopaque (which can interfere with fusion assessment on x-ray) while also having a high modulus of elasticity (which can stress shield the bone graft). Injection molded CFRP is very brittle and susceptible to fracture during insertion. Unreinforced PEEK is much less brittle but also weaker than carbon-filled PEEK, requiring thicker-walled designs (diminishing space for bone graft). In addition, the teeth of an unreinforced PEEK cage are softer and so may allow more migration. Both PEEK and carbon-filled PEEK are radiolucent.

U.S. Pat. No. 6,824,565 (“Muhana”) discloses implant and instrument designs wherein some of the implant embodiments have planked designs and a mating inserter instrument. However, the disclosed inserter wraps around the exterior of the implant and partially into grooves on the implant. Moreover, the disclosed implant is derived from bone and is not hollow. The insertion technique disclosed by Muhana requires a cutting tool to prepare a channel for the implant.

US Patent Publication 2008-0154377 (Voellmicke) discloses a cage adapted to contain an inserter within its inner volume during insertion.

US Patent Publication 2009-0198339 (Kleiner) discloses an implantable intervertebral fusion cage including a removable means for retaining material inside of the cage during implantation. Embodiments are directed toward an implantable intervertebral fusion cage that includes at least one removable shield or veneer that is capable of retaining a surgically useful material, such as a spinal fusion-inducing material, inside of the fusion cage during implantation and/or until the shield or veneer is removed. None of the Kleiner shields cover the teeth of the cages.

U.S. Pat. No. 7,569,054 (Michelson) discloses disc space docking and distraction means. In particular, Michelson discloses an apparatus for use in human surgery has a tubular member with a passage for providing protected access to a surgical site. The passage has a minimum width transverse

to the mid-longitudinal axis of the tubular member. Two opposed extensions extend from the distal end of the tubular member. The extensions each have a length and a maximum height perpendicular to the length. The maximum height of the extensions are less than the length of each extension and greater than one-half the minimum width of the passage. Each extension has an interior surface at least in part facing the mid-longitudinal axis of the tubular member. The interior surfaces of the extensions are spaced apart from one another along the length of each extension a distance no less than the minimum width of the passage. Each extension has opposed bone contacting surfaces configured to contact portions of bone.

Other relevant instruments include those disclosed in U.S. Pat. No. 7,008,431 (“Simonson”); U.S. Pat. No. 5,797,909 (“Michelson II”); U.S. Pat. No. 6,080,155 (“Michelson III”); U.S. Pat. No. 6,096,038 (“Michelson IV”); U.S. Pat. No. 7,300,440 (“Zdeblick”); and US Patent Publication 2009-0198339 (“Kleiner”).

In summary, the insertion of both smooth and toothed intervertebral cages has proven to be problematic due to high resistance forces (friction) and interference fit of the cage and intervertebral space. Whereas toothed cages are difficult to insert, cages with smooth upper and lower surfaces have demonstrated undesirable migration.

Current injection-molded PEEK or carbon fiber reinforced PEEK (CFRP) cages are difficult to insert because of the interference fit between the textured/spiked surfaces of the implant and the bony endplates.

The difficulty of direct, unshielded cage insertion and final positioning in the disc space also increases the likelihood of bony endplate damage, as the disc space preparation, FSU distraction forces and insertion trajectory are variable.

Consistent and accurate placement of the posteriorly inserted spinal fusion cages is difficult because light tamping and impaction are employed for final positioning. Cages have been over inserted via pushing or impaction through the annulus and into the adjacent body cavities and/or structures.

Most cages are filled with graft and/or bone inducing substances including BMP and collagen sponge. It has been found that the graft and/or BMP frequently drips or falls out of the graft retaining pockets. The uncontrolled delivery of the BMP/graft can irritate adjacent tissues and prompt bone formation in undesired locations including heterotopic bone.

Many spinal fusion procedures require either pre and or post packing of the disc space, thereby increasing patient risk and operative time.

#### SUMMARY OF THE INVENTION

In accordance with the present invention, there is provided a cage insertion instrument adapted to insert an intervertebral interbody cage through a conventional spinal surgery approach (such as ALIF, TLIF, PLIF, or LLIF). In preferred embodiments, this instrument includes a cannulated sheath comprising a) a proximal cannulated portion, and b) a distal cannulated sheath that surrounds the cage during insertion into the disc space. The sheath shields the textured surface of the cage from the vertebral body endplates, thereby preventing their stress-inducing engagement therewith. The sheath has an expandable tapered or bulleted distal tip to ease insertion and placement of the instrument (and cage) within the disc space. Once the cage is inserted to its proper depth in the disc space, the sheath can be retracted while the cage is held stationary by a threaded rod

disposed within the sheath. This retraction exposes the sharp, textured surface of the cage for engagement with the vertebral endplates.

Therefore, the inserter of the present invention provides a number of benefits to the spinal surgeon. In particular, it provides initial distraction of the disc space, improves the ease of insertion and placement of an intervertebral spacer, minimizes damage to the spacer and/or endplate during spacer insertion and placement, provides a means to deliver and contain graft within the spacer and surrounding disc space, and reduces the secondary positioning and time required to implant a spacer.

The sheath also provides a delivery and containment means for bone graft and/or BMP's, bone graft can be placed either within the cage, or distal or proximal to the cage for simultaneous delivery therewith. This containment means prevents leakage during insertion into the body, during placement into the disc space, and during final deployment into the disc space.

Therefore, in accordance with the present invention, there is provided an assembly comprising:

- a) an intervertebral fusion cage having a leading end, a trailing end, an upper face and a lower face, and
- b) an inserter comprising:
  - i) a cannulated rod holder having a bore therethrough,
  - ii) a rod received within the bore of the cannulated rod holder, the rod adapted to mate with the cage,
  - iii) a cannulated sheath receiving the cannulated rod holder, the sheath having a plurality of sheath portions extending distally therefrom, and

wherein a first sheath portion has an inner portion bearing against the lower face of the cage, and

wherein a second sheath portion has an inner portion bearing against the upper face of the cage.

The present invention includes a retractable sheath that holds a cage as it is inserted into the disc space, thereby shielding the sharp teeth of the cage from bony endplates and delivering graft to the disc space. Whereas conventional instrument systems that use delivery tubes for the cage do not place the tube into the disc space (but rather between the skin and the entrance to the disc space), the tubular sheath of the present invention enters the disc space.

The present invention also includes tubular, expandable spinal disc graft containment means.

Also in accordance with the present invention, there is provided a method of delivering a fusion cage to an intervertebral disc space bounded by adjacent vertebral endplates, comprising the step of:

- a) delivering the fusion cage into the disc space without contacting its surfaces to the vertebral endplates during delivery.

In preferred embodiments thereof, a sheath is interposed between the cage surfaces and the endplates to prevent contact therebetween during delivery.

Also in accordance with the present invention, there is provided a method of delivering a fusion cage into the disc space, comprising the steps of:

- a) inserting a distal end of a cannula into an intervertebral disc space,
- b) delivering the fusion cage through the cannula into the disc space.

#### DESCRIPTION OF THE FIGURES

FIGS. 1A-1D disclose various views of an inserter of the present invention having four main components.

5

FIG. 2 discloses a fusion cage being held by an inserter of the present invention, along with the space available therein for graft placement.

FIGS. 3A-3D disclose various views of an inserter of the present invention, wherein the sheath has a rectangular cross-section that tracks the cross-section of the fusion cage.

FIGS. 4A-4D disclose various steps by which the inserter of FIGS. 3A-3D inserts a cage into a disc space.

FIG. 5 discloses an inserter of the present invention having three main components.

FIGS. 6A-6B discloses an inserter of the present invention having two main components.

FIGS. 7A-7B discloses an inserter of the present invention having a curved distal sheath.

FIGS. 7C-7D discloses the distal and proximal loading of the inserter of FIGS. 7A-7B.

FIGS. 8A-8D disclose the sequential advance of the curved distal sheath of an inserter of the present invention.

FIG. 9 discloses a distal portion of an inserter of the present invention having a modular expanding sheath tip.

FIGS. 10A-10B disclose the insertion of multi-component cages with the inserter of the present invention.

FIGS. 11A-11C disclose a distal portion of an inserter of the present invention fitted with various slit sheaths.

FIG. 12A discloses a docking port component of the present invention having distally extending securement teeth.

FIG. 12B discloses a docking port component of the present invention having a distally located adjustable collar.

#### DETAILED DESCRIPTION OF THE INVENTION

In some embodiments, the instrument comprises two, three, four or more components.

Now referring to FIGS. 1A-1D, there is provided an assembly of the present invention in which the inserter has four components: a sheath, a cannulated rod holder, a rod and a docking port. In particular, the assembly comprises:

- a) an intervertebral fusion cage 1 having a leading end 3, a trailing end 5 having a threaded hole 6, an upper face 7 and a lower face 9, and
- b) an inserter 11 comprising:
  - i) a cannulated rod holder 13 having a bore therethrough and a distal end portion 17 having a distal end 18 bearing against the trailing end of the cage,
  - ii) a rod 22 received within the bore of the cannulated rod holder, the rod having a threaded distal end 20 mating with the threaded hole of the cage,
  - iii) a cannulated sheath 19 adapted to receive the cannulated rod holder, the sheath having a plurality of sheath portions 23,25 extending distally therefrom,
  - iv) a docking port 33 having a bore therethrough and a substantially frustoconical distal end 35, wherein the cannulated sheath is slidingly received in the docking port and

wherein a first sheath portion 23 has an inner portion 24 bearing against the lower face of the cage, and

wherein a second sheath portion 25 has an inner portion 26 bearing against the upper face of the cage.

In general, the rod is a proximally-handled instrument that mates with the cage and typically has a distally extending screw thread similar to conventional posterior cage inserters. It is typically called a threaded securement rod. Typically, the rod has a threaded distal end, the trailing end of the cage has a mating threaded hole, and the threaded distal end of the

6

rod is received in the mating threaded hole of the cage to secure the cage. The threaded connection allows the surgeon to keep the cage in its inserted position while the sheath is removed therefrom.

The function of the cannulated rod holder is to hold cage in position as sheath is retracted. As shown in FIG. 2, it typically has distally extending feet 24 for bearing against the trailing end of the cage. Thus, in some embodiments, the cannulated rod holder may be considered a cannulated cage holder as well. In some embodiments, the cannulated rod holder can further include a cylindrical flange or "piston" 99 that extends radially about the distal portion of the rod. This piston allows for sealed graft or BMP delivery distally thereof. As shown in FIG. 2, graft materials 31 can be placed within the cage, or placed distal and/or proximal to the cage within the cage holder, thereby eliminating the need to pre-pack or post-pack the disc space with graft materials. The piston feature provides a proximal stop for such graft placement proximal of the cage.

Referring back to FIGS. 1A-1D, the bulleted sheath 19 is a retractable cannulated sheath that slides over the rod/rod holder assembly. The sheath preferably has a very smooth (i.e., low coefficient of friction), semi-rigid inner wall 24,26 with a wall thickness of approximately 0.5 mm or less. Preferred materials of construction for the sheath include: polymeric (such as polyethylene, polypropylene, PEEK, polyurethane, and PTFE) or metallics (such as stainless steel, titanium alloy, and nitinol). One preferred sheath is constructed of a radiolucent material that allows for fluoroscopic imaging of the cage. In some embodiments, the sheath has a bulleted distal tip that optionally possesses at least one expansion slot (with four such slots shown in FIGS. 1A-1D, 2 and 4A-4D). Now referring to FIGS. 3A-3D, in some embodiments, the sheath can be produced in varying shapes, including those having a rectangular transverse cross-section 50.

In use, and now referring to FIG. 2, the sheath typically contains bone graft 31. In some cases, at least a portion of the bone graft is located within the cage. In others, at least a portion of the bone graft is located outside of the cage.

In some embodiments, the sheath comprises a distal pair of cup-like, opposed sheath half leaves, while in others the sheath comprises four sheath quarter leaves. Now referring to FIGS. 6A-6B, the proximal portion 98 of each distal sheath leaf 23, 25 is adapted to flex, thereby allowing the distal tip of the distal sheath leaf to open and close. In preferred embodiments, in their collapsed arrangement, the distal sheath leaves form a substantially conical shape distally, thereby forming a distal bullet tip. In other cases, the distal sheath leaves form a substantially tubular sheath shape proximally. In this way, the collective shape of the distal sheath leaves is much like that of a bulleted cage—i.e., it has a tubular body and a bulleted distal tip.

The distal sheath portions can also possess smooth outer surfaces to reduce friction and thereby increase the ease of insertion.

Typically, and now referring to FIG. 3A-3D, the inserter further comprises: iv) a docking port 33 having a bore therethrough and a substantially frustoconical distal end 35, wherein the cannulated sheath is slidingly received in the docking port. The docking port acts as a retractor for soft tissue and helps to place the cannulated sheath upon the vertebral body or within the disc. The docking port can also control insertion angle and depth of the bulleted sheath with enclosed cage. In some embodiments, the port is a cannu-

lated body having a throughbore and a distal end portion having a tapered, cannulated, pyramidal or frustoconical shape.

The present invention is believed to be compatible with any conventional fusion cage. Typically, the upper and lower faces of the cage comprise a plurality of teeth. In some embodiments, the cage has a substantially rectangular transverse cross-section and the sheath has a corresponding substantially rectangular transverse cross-section. In some embodiments, the cage has a substantially circular transverse cross-section and the sheath has a corresponding substantially circular transverse cross-section. In some embodiments, the cage has a substantially elliptical transverse cross-section and the sheath has a corresponding substantially elliptical transverse cross-section.

Typically, the cage distracts the disc space during insertion. It is easy to insert and optimizes clinical performance once in place because it resists migration and subsidence, has an appropriate stiffness for load sharing, is preferably radiolucent, and has a shape that is able to contain injected graft material such as growth factors. In addition, the cage is robust over a wide variation of surgical technique because it will not break even when large forces are applied thereto.

The cage of the present invention is preferably compatible with the broad use of injectable paste-like bone grafting materials, such as BMP-containing pastes. It may be inserted empty and then filled with graft in-situ. With the availability of injectable pastes, cages will no longer require large, contiguous internal volumes to accept morselized/granular bone graft. Spaces can be smaller and more numerous. The cage of the present invention will be contained and shielded by the bulleted sheath and will therefore not experience as large impact loads during insertion.

Now referring to FIGS. 3A-3D, in some embodiments, the cage has a transverse cross-section **50** that is rectangular, and the transverse cross sections of the port, the bulleted sheath and the cannulated cage holder can substantially match that of the cage itself. This is a preferred embodiment, as it minimizes the over-distraction required in other embodiments for cage insertion.

Now referring to FIGS. 4A-4D, in one method of using the four-component inserter with the present invention, the sequence of implantation steps are as follows:

- (1) fill the cage and sheath with bone graft.
- (2) dock the docking port **33** onto the disc space. The port can be used to direct the angle and location of any desired disc clearing effort as well as cage implantation.
- (3) advance of the bulleted sheath. The bulleted sheath **19** containing the graft and cage are advanced to the desired depth and location. The bulleted sheath reduces insertion forces due to its shape and its lubricious material of construction, while encasing the cage and its associated securement features (teeth).
- (4) imaging. Imaging is performed to confirm cage positioning.
- (5) sheath retraction: The sheath is retracted from the cage **1**, thereby exposing the cage and its contents to the vertebral endplates.
- (6) Cage Disconnection/Release: Following retraction of the sheath, the threaded rod is disengaged from the cage, thereby leaving the cage in the disc space at the desired location.
- (7) Added Graft Injection (optional): As a last step, additional graft can be deployed via packing or injecting through the cannulated cage holder.

Now referring to FIG. 5, in some embodiments, the inserter instrument of the present invention is a three-component design that does not have a docking port. This design includes:

- a) a threaded securement rod **22** that mates with the cage via screw threads in a manner similar to conventional posterior cage inserters;
- b) a cannulated cage holder **13** to receive the rod and hold the cage in position as the sheath is retracted; and
- c) a bulleted cannulated sheath **19**.

In using the inserter of FIG. 5, the bulleted sheath (containing the graft and the cage **1**) is advanced to the desired location. Due to the shape and lubricious material which encases the cage and associated securement features (such as teeth), the bulleted sheath reduces insertion forces. Imaging is then performed to confirm positioning.

Now referring to FIGS. 6A-6B, there is provided a simple two-component embodiment of the present invention employing a cage pusher/holder **61** and an insertion sheath **19**. The cage pusher/holder features the threaded feature of the rod and the shoulder **63** of the cannulated rod holder of FIGS. 1A-1D. The cage pusher/holder holds the cage **1** in position as sheath is retracted, and the feet can act as a piston for sealed graft delivery. The bulleted sheath **19** (containing the graft and cage) is advanced to the desired location. The bulleted sheath reduces insertion forces due to the shape and lubricious material which encases the cage and associated securement features (such as teeth). Imaging is performed to confirm positioning.

In some embodiments, and now referring to FIGS. 7A and 7B, the cages of the assembly of the present invention have curved sidewalls. Typically, these curved cages are placed in an anterior portion of the disc space. The curved sheath reduced the need for post-insertion manipulation of these cages with conventional insertion methods which is more challenging due to the final position of the cage and the increased manipulation and forces that are required to push it in.

In preferred cases, the sheath is curved to help deliver these curved implants. In cases in which the sheath is curved, the sheath preferably comprises a superelastic shape memory material and has a curved configuration and a straight configuration. The sheath of the insertion device of the present invention also possesses curved sidewalls **71,72**, thereby providing for shielded placement of the curved cage in the desired final location prior to sheath retraction. In one type of preferred curved inserter device (FIG. 7C), there is distal loading of the cage, allowing for minimal diameter of the bulleted sheath and cannulated cage holder. The second type of curved inserter device (FIG. 7D) allows for proximal cage loading, but requires an increased diameter of the bulleted sheath and cannulated cage holder. Such a curved inserter can be made to be self-steerable by using a memory metal or memory polymer sheath, or by using a threaded inserter that recovers its unloaded position upon deployment from the docking port.

In some embodiments, and now referring to FIGS. 8A-8D, the cage inserter can be steered into its desired location via cables or other means, wherein the sheath **19** has a tensioning cable **75** attached thereto.

In some embodiments, and now referring to FIG. 9, the cage inserter can have a modular expanding tip **77**. The distal tip of the bulleted sheath can be modular and be attached to the proximal portion of the sheath. The modular component can be prepackaged sterile and marketed with

the matching cage size contained within to minimize over-distracted. The entire inserter can also be polymeric and/or disposable.

In some embodiments, and now referring to FIGS. 10A and B, multiple cages 81 may be deployed. A plurality of curved or straight cages (or a combination of curved and straight cages) of a size smaller than a standard cage can be inserted either in succession or simultaneously. In some embodiments thereof, multiple cages can be connected to each other by a cable 83 to provide a more stable construct.

In some embodiments, and now referring to FIGS. 11A-C, the split sheath comprises a longitudinal gap 91 between sheath portions (i.e., the sheath portions do not contact each other). This gap allows for different cage heights to be handled by the same sheath component, thereby reducing the number of potential instruments in the set.

In some embodiments, and now referring to FIGS. 12A-B, the docking port could have multiple means for attachment, such as teeth, to provide security in between or onto the vertebral bodies. In some embodiments, and now referring to FIG. 12A the docking port can have one or more tongs or spikes 51 extending distally from its distal end portion to assist in holding position upon the vertebral bodies or within the disc. Typically, the docking port also has a proximal handle 53

Now referring to FIG. 12B, the docking port could also include an adjustable collar 93 and incremental adjustment grooves 95. These components could be used to both dock onto the vertebral bodies and control the depth to which the instrument is introduced into the disc space.

Typically, the inserter of the present invention can be made out of any material commonly used in medical instruments. The cage insertion instrument can be made available in a sterile version with preassembled cage and graft, or in a reusable version. If the inserter is designed to be reusable, then it is preferred that all of its components be made of stainless steel. If the inserter is designed to be disposable, then it is preferred that at least some of the components be made of plastic. Preferably, at least one component of the inserter is sterilized. More preferably, each component is sterilized.

The intervertebral fusion cage of the present invention may be manufactured from any biocompatible material commonly used in interbody fusion procedures. In some embodiments, the cage is made from a composite comprising 40-99% polyarylethyl ketone PAEK, and 1-60% carbon fiber. Such a cage is radiolucent. Preferably, the polyarylethyl ketone PAEK is selected from the group consisting of polyetherether ketone PEEK, polyether ketone ketone PEKK, polyether ketone ether ketone ketone PEKEKK, and polyether ketone PEK. Preferably, cage is made from woven, long carbon fiber laminates. Preferably, the PAEK and carbon fiber are homogeneously mixed. Preferably, the composite consists essentially of PAEK and carbon fiber. Preferably, the composite comprises 60-80 wt % PAEK and 20-40 wt % carbon fiber, more preferably 65-75 wt % PAEK and 25-35 wt % carbon fiber. In some embodiments, the cage is made from materials used in carbon fibers cages marketed by DePuy Spine, Raynham, Mass., USA. In some embodiments, the composite is PEEK-OPTIMA™, available from Invibio of Greenville, N.C.

In other embodiments, the cage is made from a metal such as titanium alloy, such as Ti-6Al-4V. In other embodiments, the cage is made from an allograft material. In some embodiments, the cage is made from ceramic, preferably a ceramic that can be at least partially resorbed, such as HA or TCP. In other embodiments, the ceramic comprises an

oxide such as either alumina or zirconia. In some embodiments, the cage is made from a polymer, preferably a polymer that can be at least partially resorbed, such as PLA or PLG.

In preferred embodiments, the cage is provided in a sterile form.

We claim:

1. An assembly comprising:

i) an intervertebral fusion cage having curved, substantially parallel sidewalls, and

ii) an inserter instrument for inserting the intervertebral fusion cage, comprising:

a) a threaded securement rod that mates with the cage via screw threads;

b) a cannulated cage holder to receive the rod and hold the cage in position; and

c) a bulletted cannulated, extensible and retractable sheath extending from the cage holder,

wherein the sheath is curved and comprises a superelastic shape memory material having a curved configuration and a straight configuration,

wherein the cannulated cage holder holds the cage in position as the sheath is retracted, wherein the sheath comprises curved sidewalls having a geometry substantially similar to the curved, substantially parallel sidewalls of the cage, thereby providing for shielded placement of the cage in a final location prior to sheath retraction.

2. An assembly comprising:

i) an intervertebral fusion cage having curved, substantially parallel sidewalls, and

ii) an inserter instrument for inserting the intervertebral fusion cage, comprising:

a) a threaded securement rod that mates with the cage via screw threads;

b) a cannulated cage holder to receive the rod and hold the cage in position; and

c) a bulletted cannulated, extensible and retractable sheath extending from the cage holder,

wherein the sheath is curved and comprises a superelastic shape memory material having a curved configuration and a straight configuration,

wherein the cannulated cage holder holds the cage in position as the sheath is retracted, and

wherein the inserter is adapted for distal loading of the cage, thereby allowing for minimal diameter of the bulletted sheath and cannulated cage holder.

3. An assembly comprising:

i) an intervertebral fusion cage having curved, substantially parallel sidewalls, and

ii) an inserter instrument for inserting the intervertebral fusion cage, comprising:

a) a threaded securement rod that mates with the cage via screw threads;

b) a cannulated cage holder to receive the rod and hold the cage in position; and

c) a bulletted cannulated, extensible and retractable sheath extending from the cage holder

wherein the sheath is curved and comprises a superelastic shape memory material having a curved configuration and a straight configuration,

wherein the cannulated cage holder holds the cage in position as the sheath is retracted, and

wherein the inserter is adapted for proximal cage loading, thereby allowing for an increased diameter of the bulletted sheath and cannulated cage holder.

4. The assembly of claim 3 wherein the curved inserter is self-steerable by using a memory metal or memory polymer sheath.

\* \* \* \* \*