



US010314150B2

(12) **United States Patent**
Israni

(10) **Patent No.:** **US 10,314,150 B2**
(45) **Date of Patent:** **Jun. 4, 2019**

(54) **WIRELESS LIGHT ASSEMBLY AND KIT**

(71) Applicant: **Trendstar Corporation**, Fairfield, NJ (US)

(72) Inventor: **Rajesh Israni**, Fairfield, NJ (US)

(73) Assignee: **TRENDSTAR CORPORATION**, Fairfield, NJ (US)

(*) Notice: Subject to any disclaimer, the term of this patent is extended or adjusted under 35 U.S.C. 154(b) by 0 days.

(21) Appl. No.: **16/138,165**

(22) Filed: **Sep. 21, 2018**

(65) **Prior Publication Data**

US 2019/0132933 A1 May 2, 2019

Related U.S. Application Data

(63) Continuation-in-part of application No. 15/795,717, filed on Oct. 27, 2017, now Pat. No. 10,182,489.

(51) **Int. Cl.**

H05B 37/02 (2006.01)
F21V 23/00 (2015.01)
F21V 23/02 (2006.01)

(52) **U.S. Cl.**

CPC **H05B 37/0272** (2013.01); **F21V 23/007** (2013.01); **F21V 23/023** (2013.01)

(58) **Field of Classification Search**

CPC H05B 37/02; H05B 37/0027; H05B 37/0272; H05B 33/08; H05B 33/0842; F21V 23/007; F21V 23/023; F21V 15/01; F21K 9/20

See application file for complete search history.

(56) **References Cited**

U.S. PATENT DOCUMENTS

5,526,243	A *	6/1996	Masters	F21V 17/02 362/122
5,962,982	A *	10/1999	Mancuso	F21V 21/0824 250/205
8,884,531	B1	11/2014	Xu		
8,901,827	B1	12/2014	Xu		
2005/0094387	A1	5/2005	Coman		
2010/0296285	A1	11/2010	Chemel		
2011/0062888	A1	3/2011	Bondy		
2012/0134133	A1	5/2012	Kang		
2012/0262928	A1	10/2012	Matsuda		
2013/0030423	A1	1/2013	Reichert		
2013/0342131	A1	12/2013	Recker		
2015/0220109	A1	8/2015	von Badinski		
2016/0313636	A1	10/2016	Chien		
2016/0330825	A1	11/2016	Recker		

* cited by examiner

Primary Examiner — Jimmy T Vu

(74) *Attorney, Agent, or Firm* — Leason Ellis LLP

(57) **ABSTRACT**

A wireless light kit includes a wireless light unit that comprises a housing having an interior compartment that contains a processor and a power source and a light source that is powered by the power source and operatively connected to the processor. The kit also includes two different types of mounting back plates, namely a first back plate and a second back plate. The first back plate is configured to mate with the housing and the second back plate is configured to mate with the housing so as to cover at least a portion of the rear face of the housing and further includes a stake extending outwardly therefrom and being configured for insertion into a ground surface for supporting the wireless light unit above the ground surface. An optional stake extender is provided to extend the length of the stake.

15 Claims, 14 Drawing Sheets

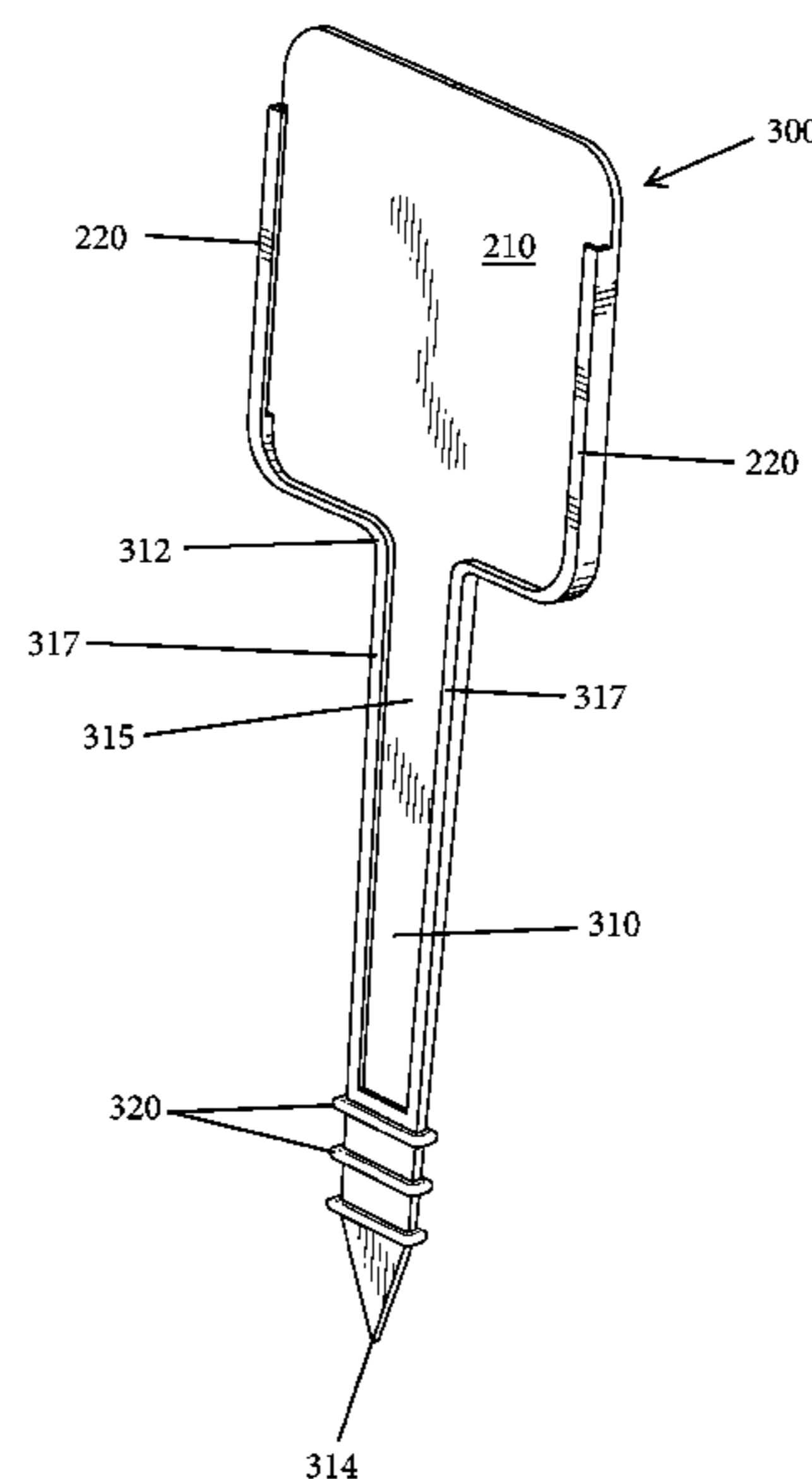
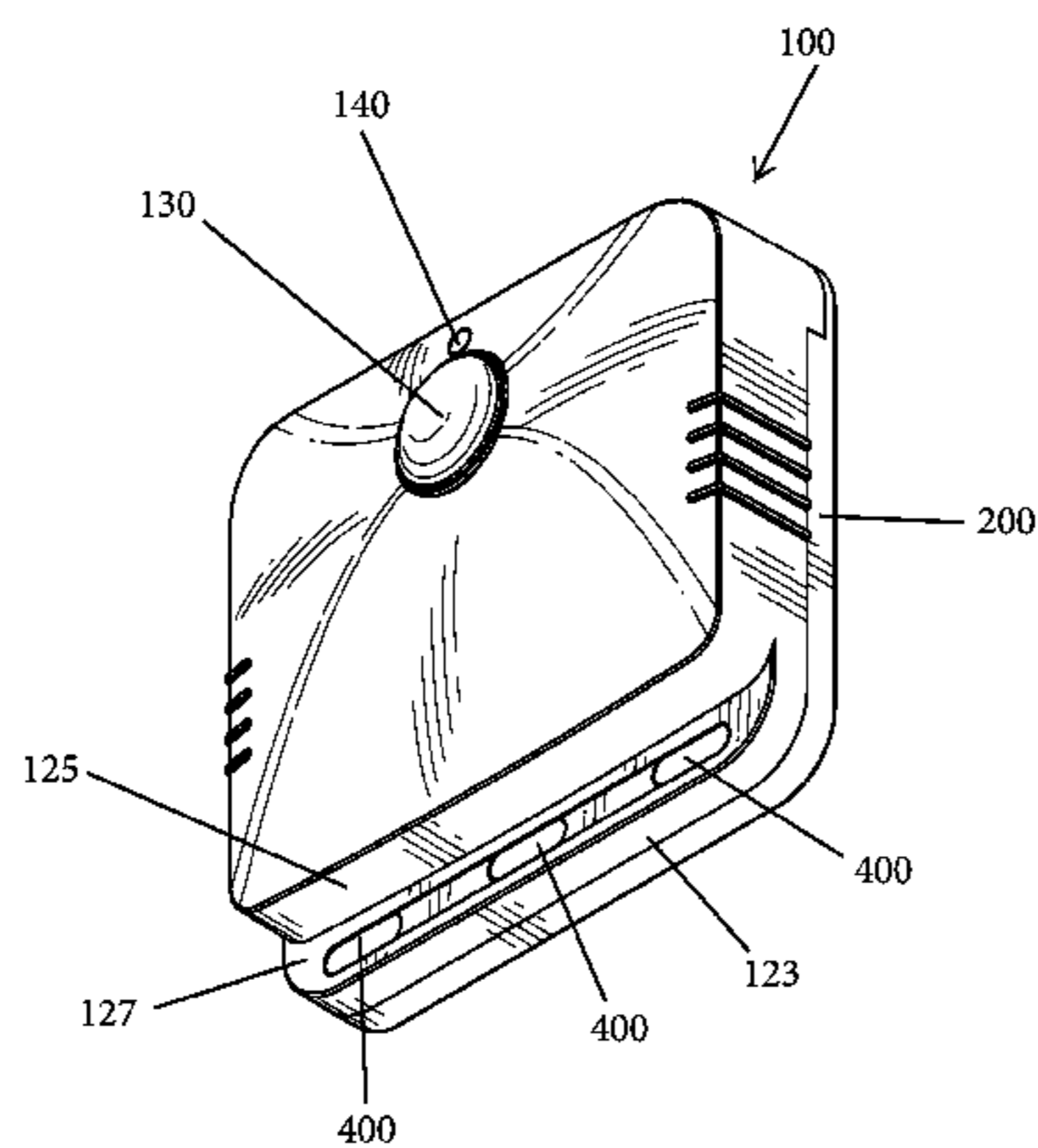

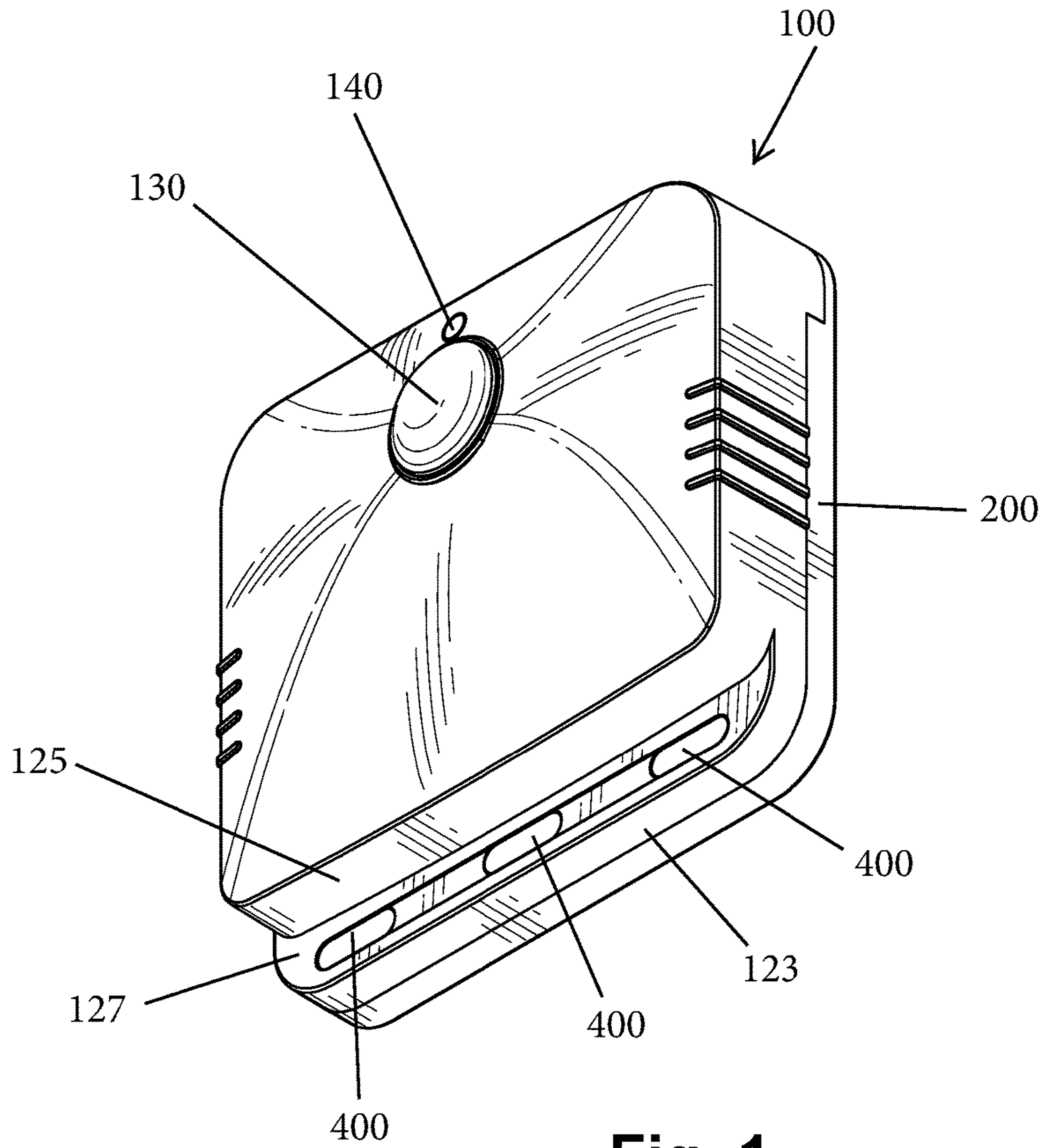

Fig. 1

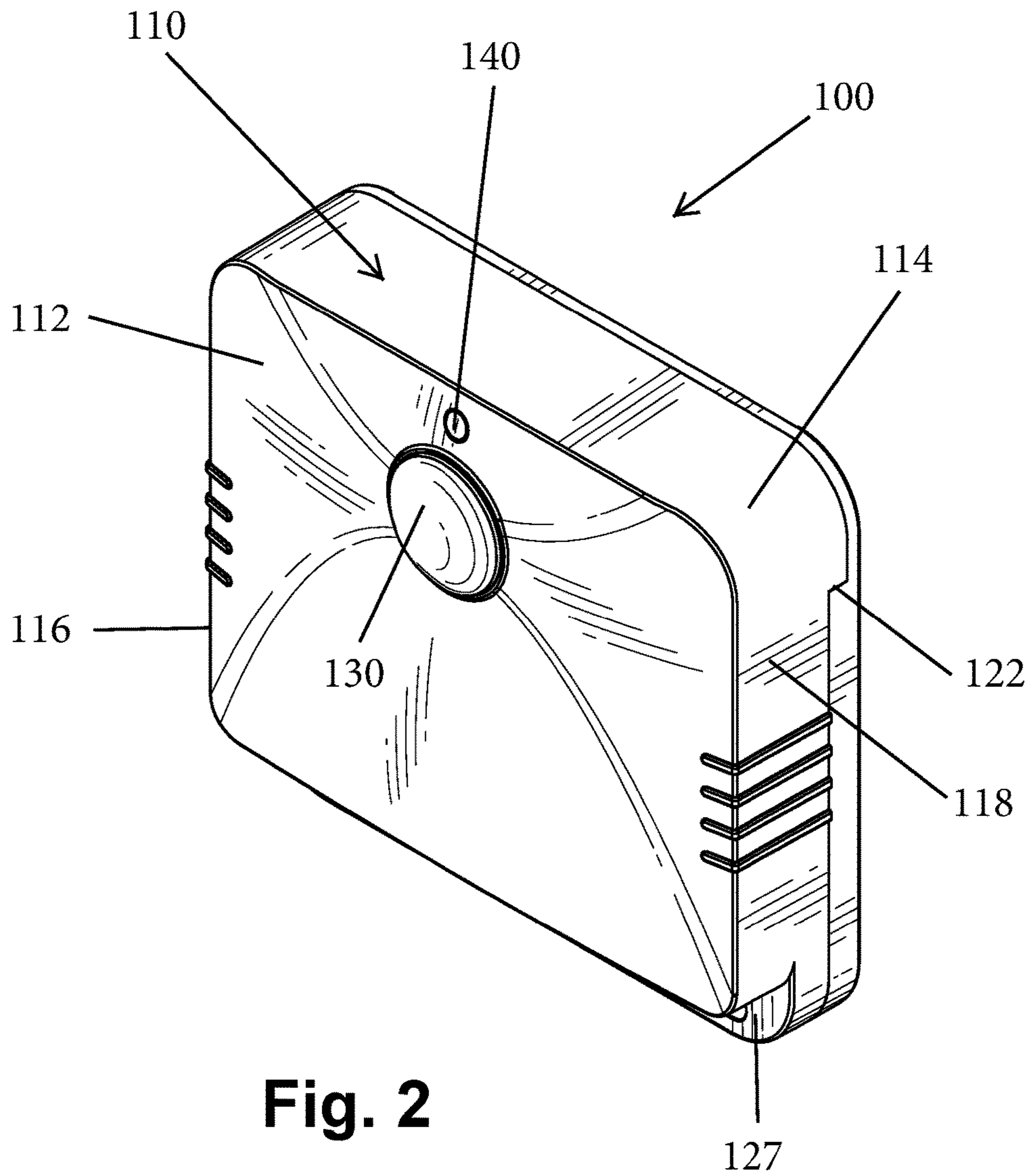

Fig. 2

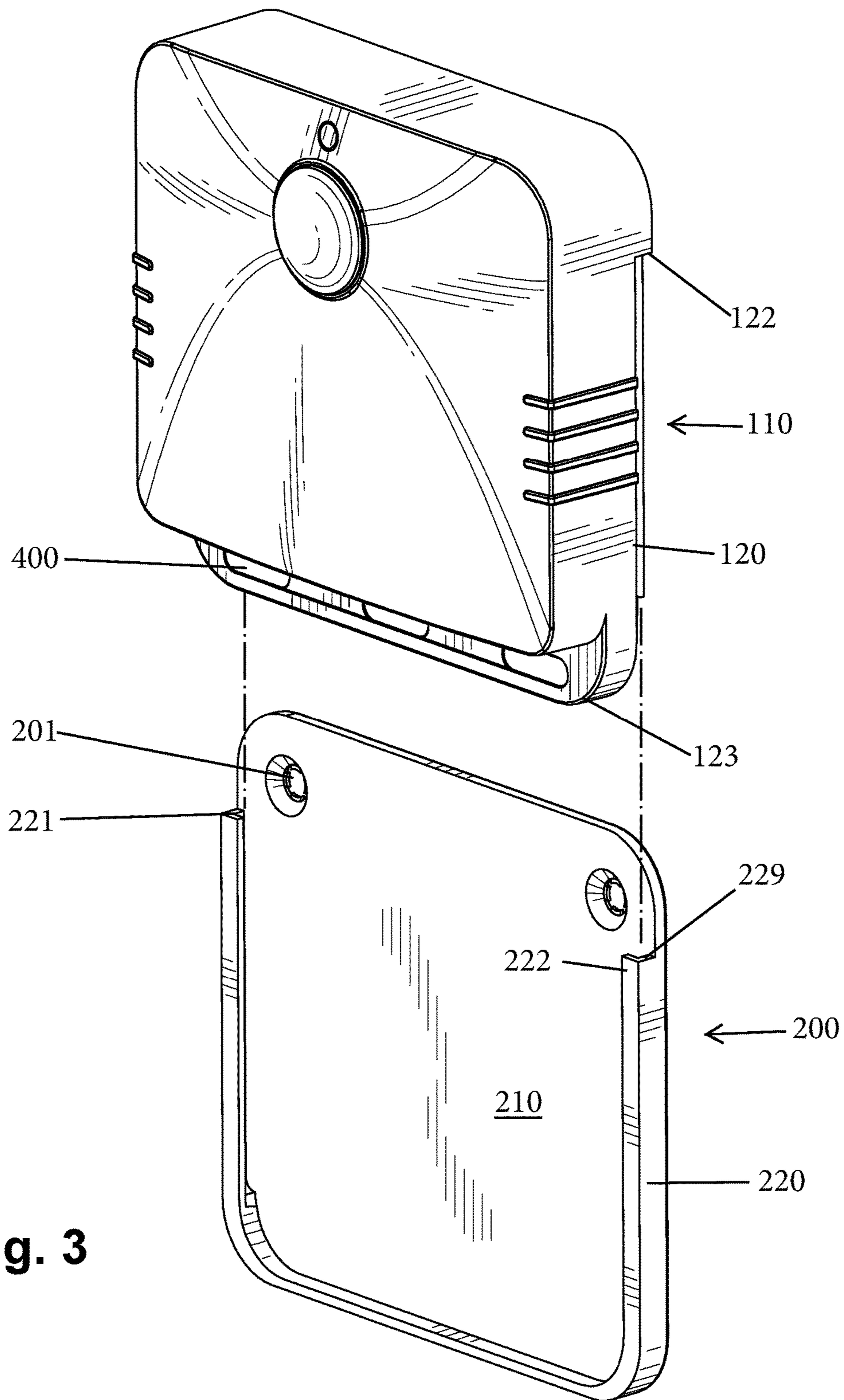

Fig. 3

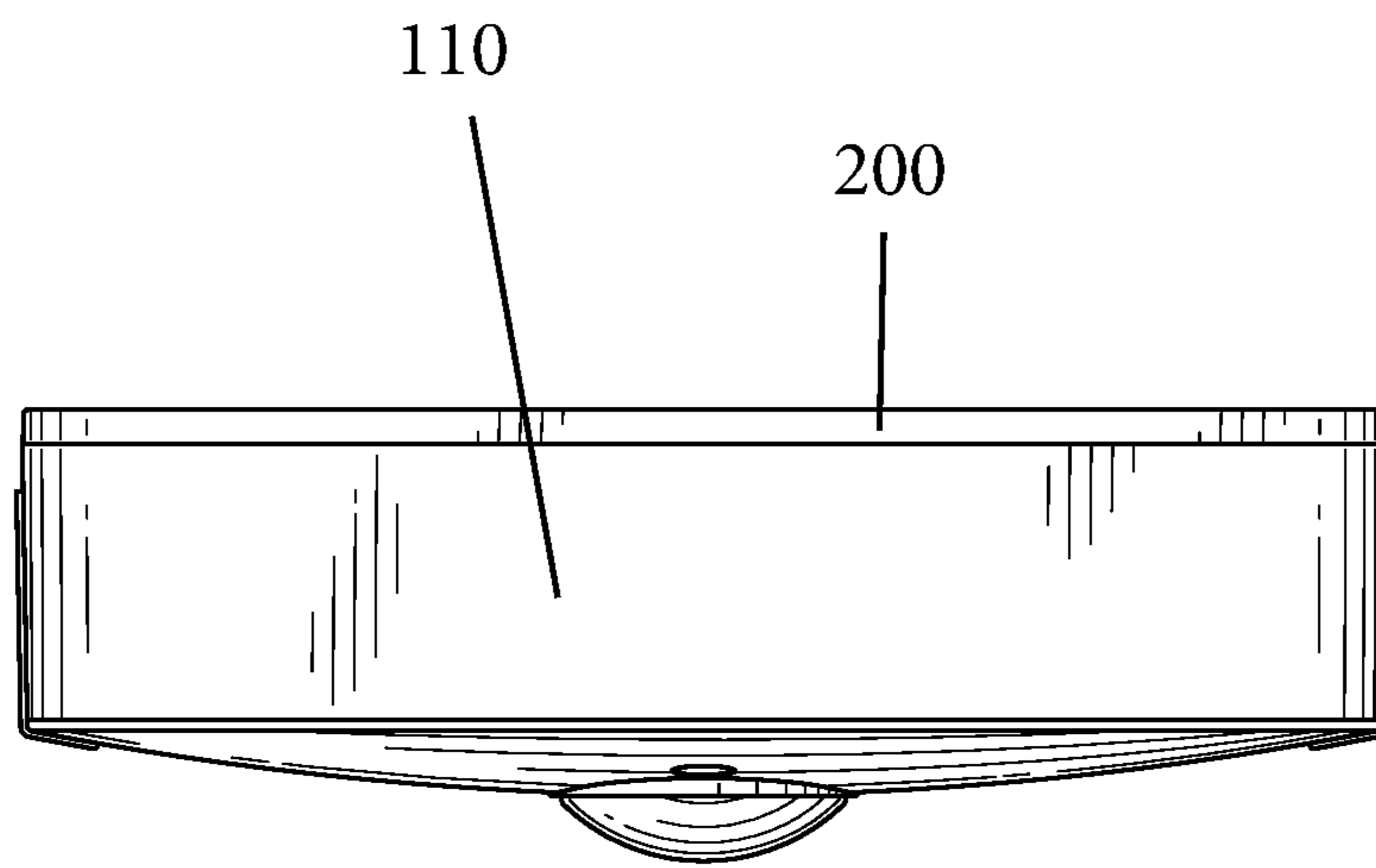

Fig. 4

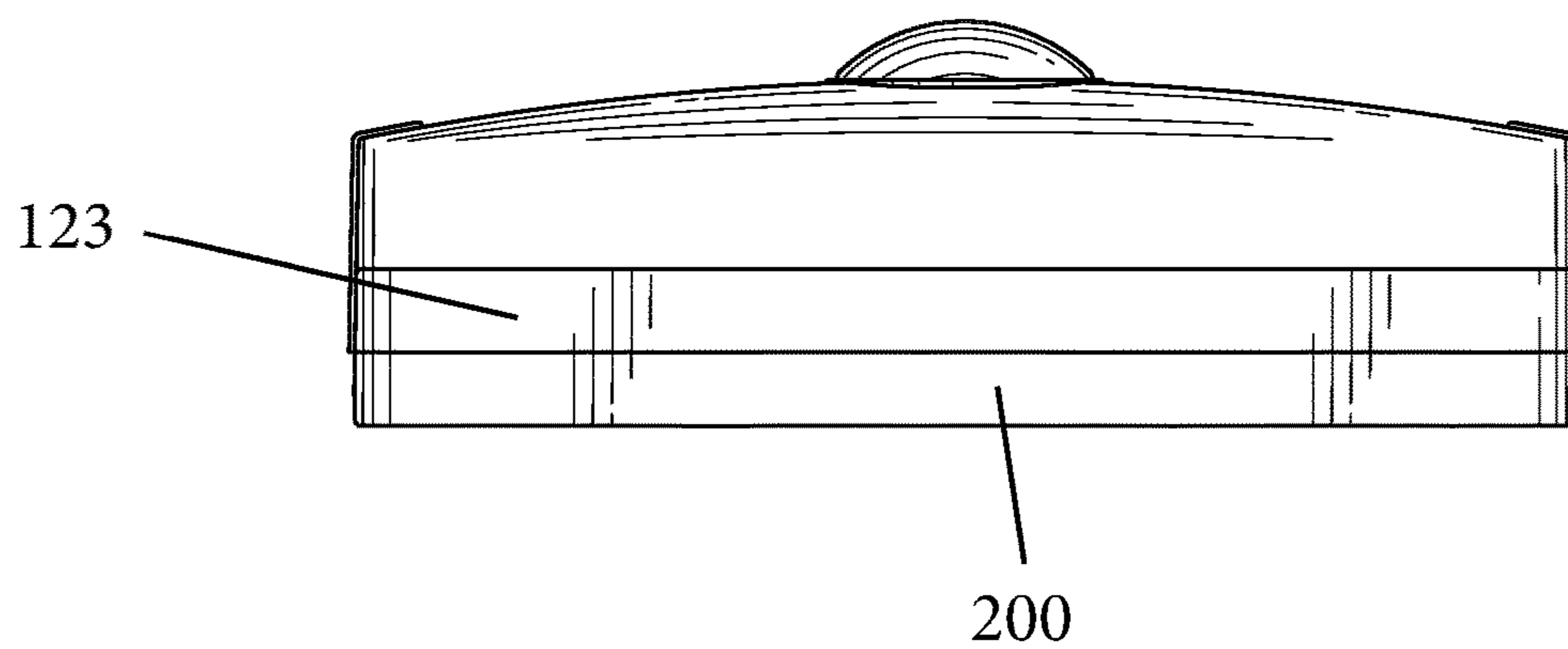

Fig. 5

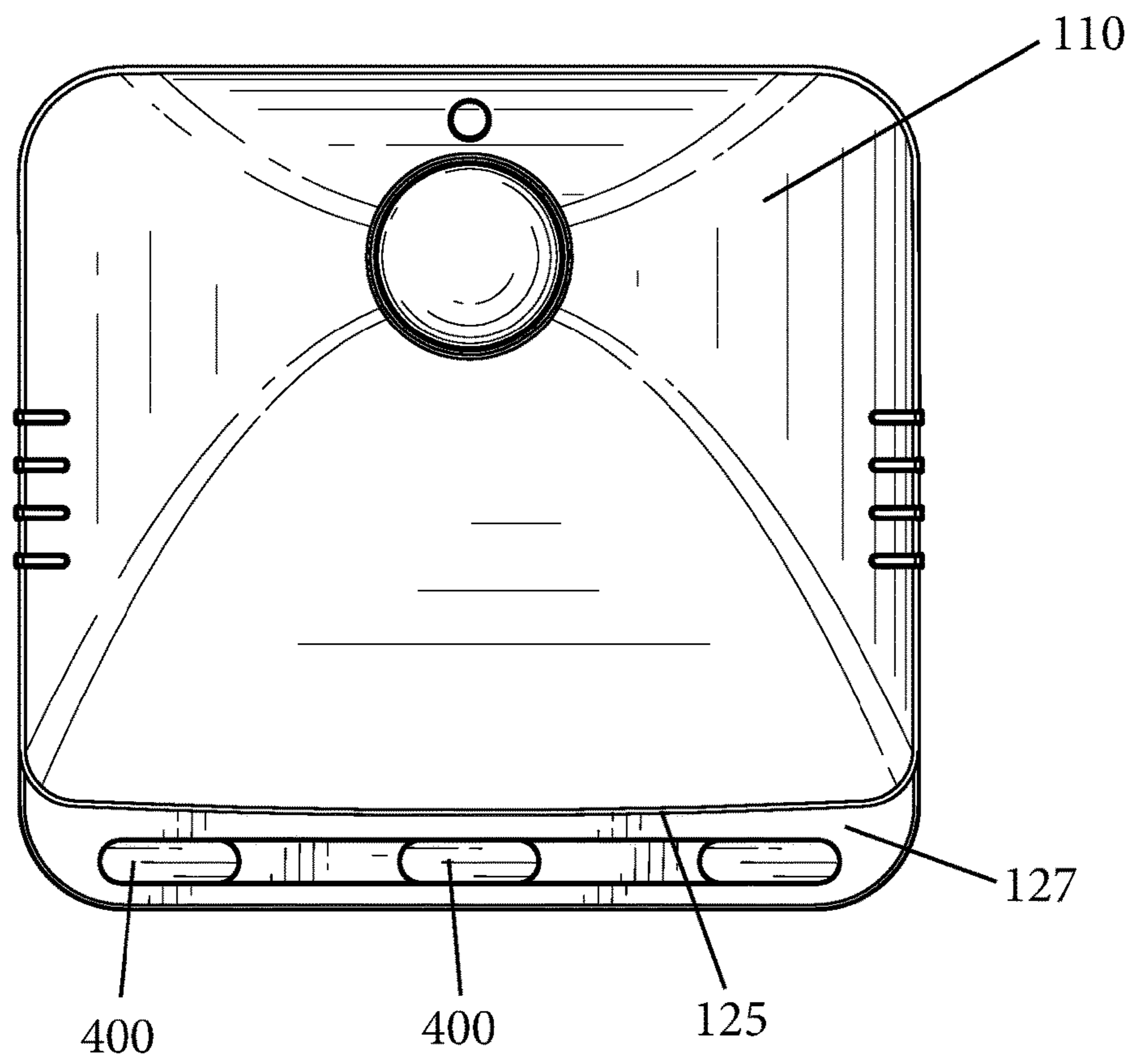

Fig. 6

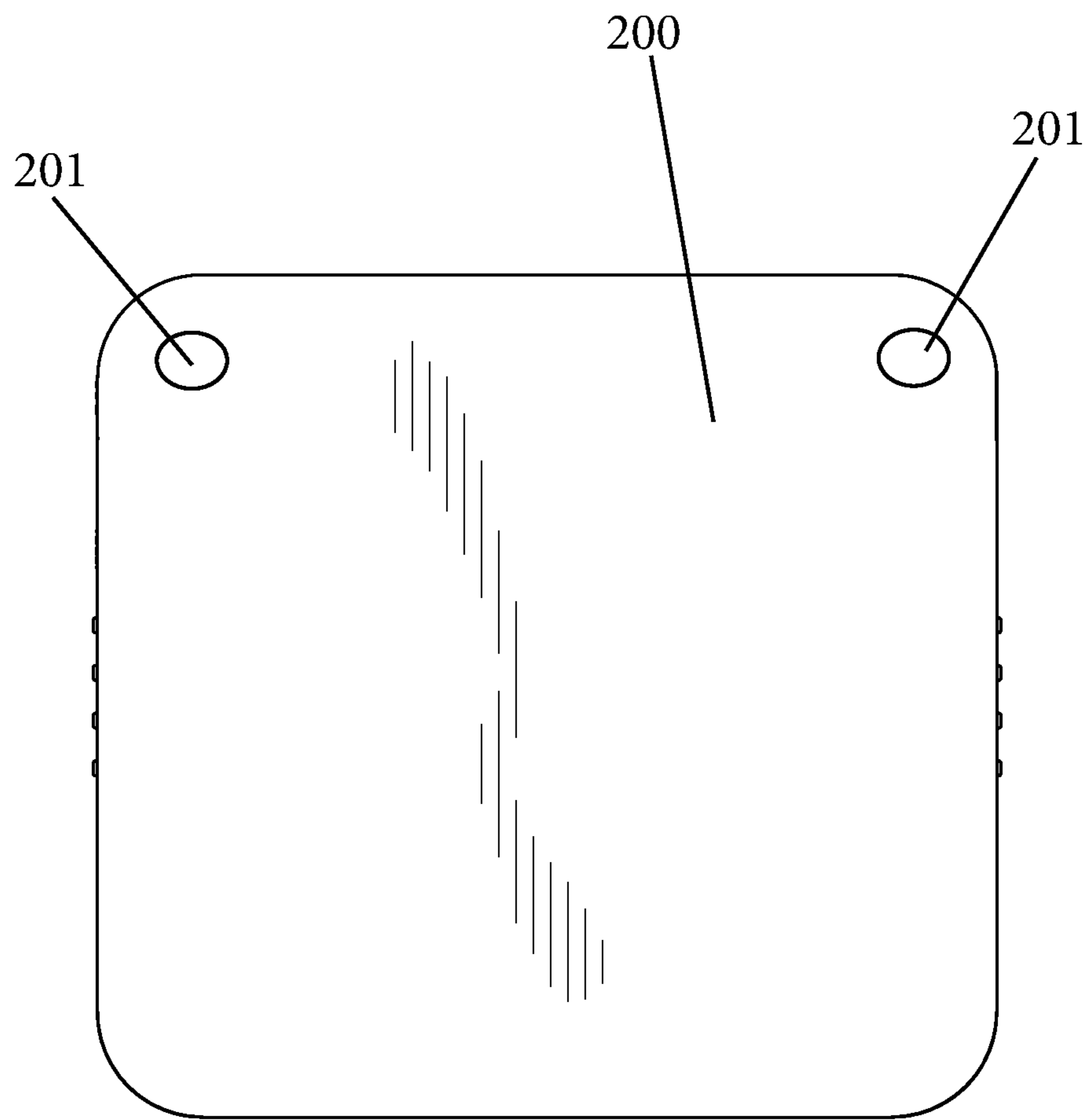

Fig. 7

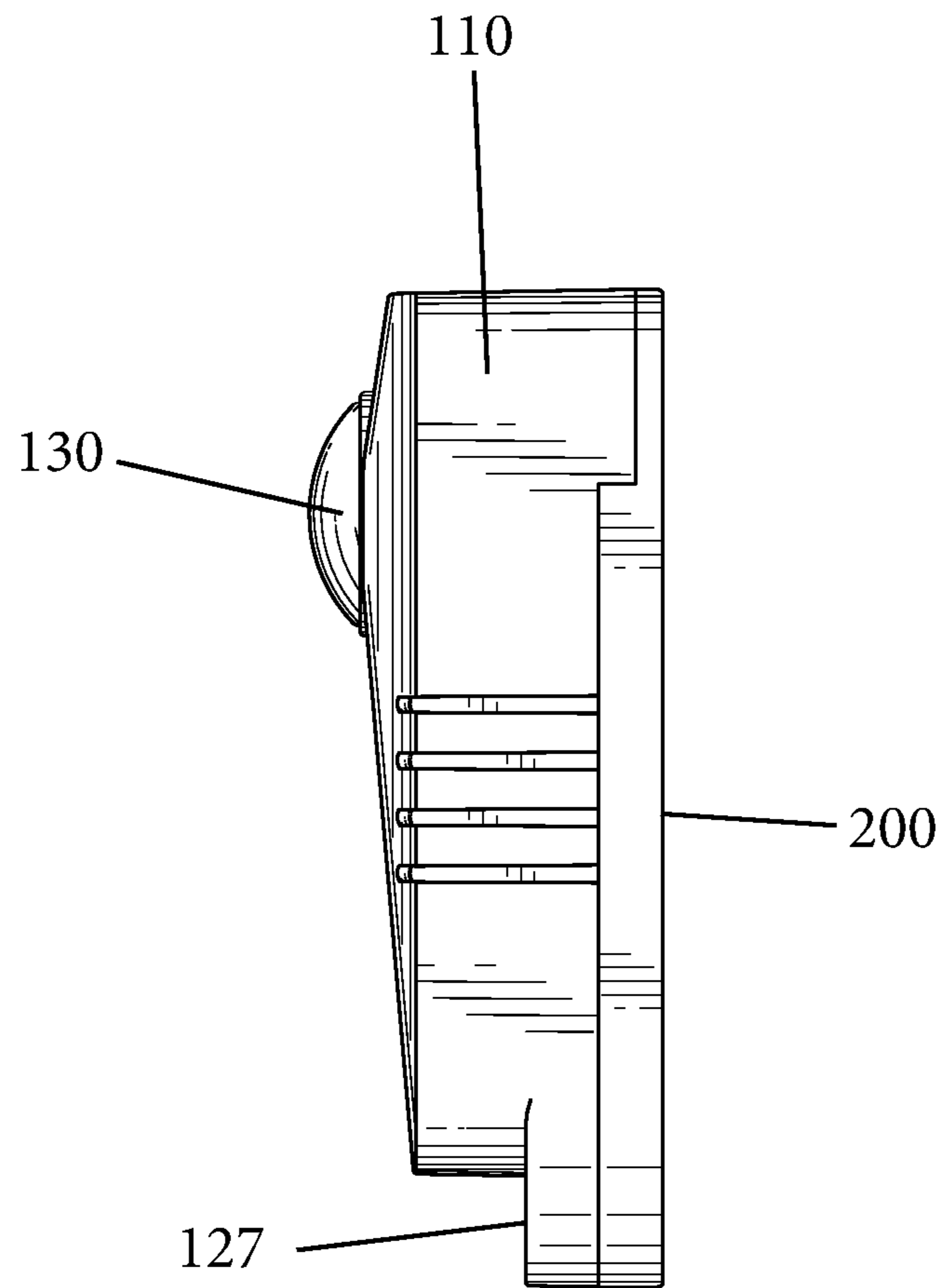

Fig. 8

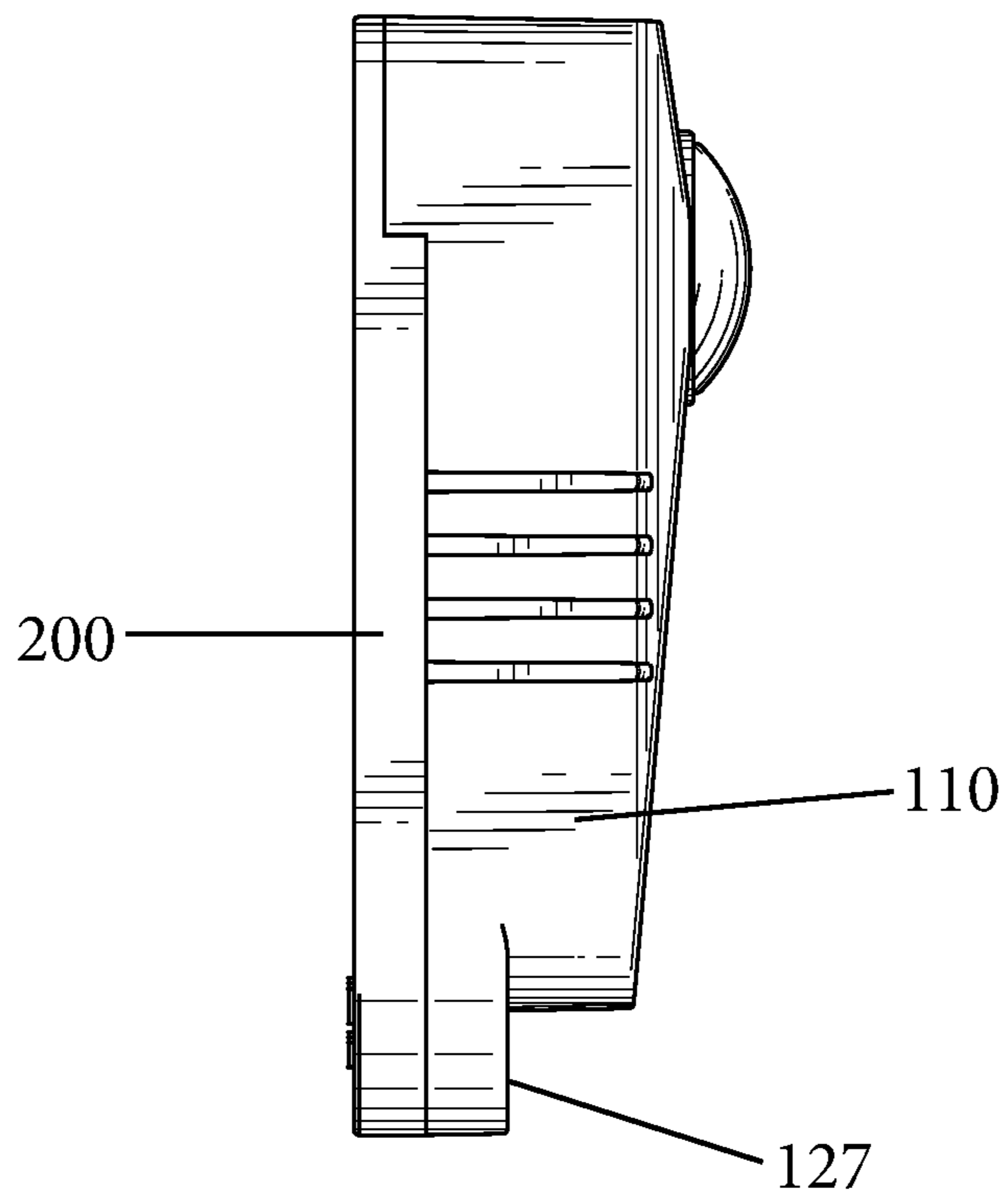

Fig. 9

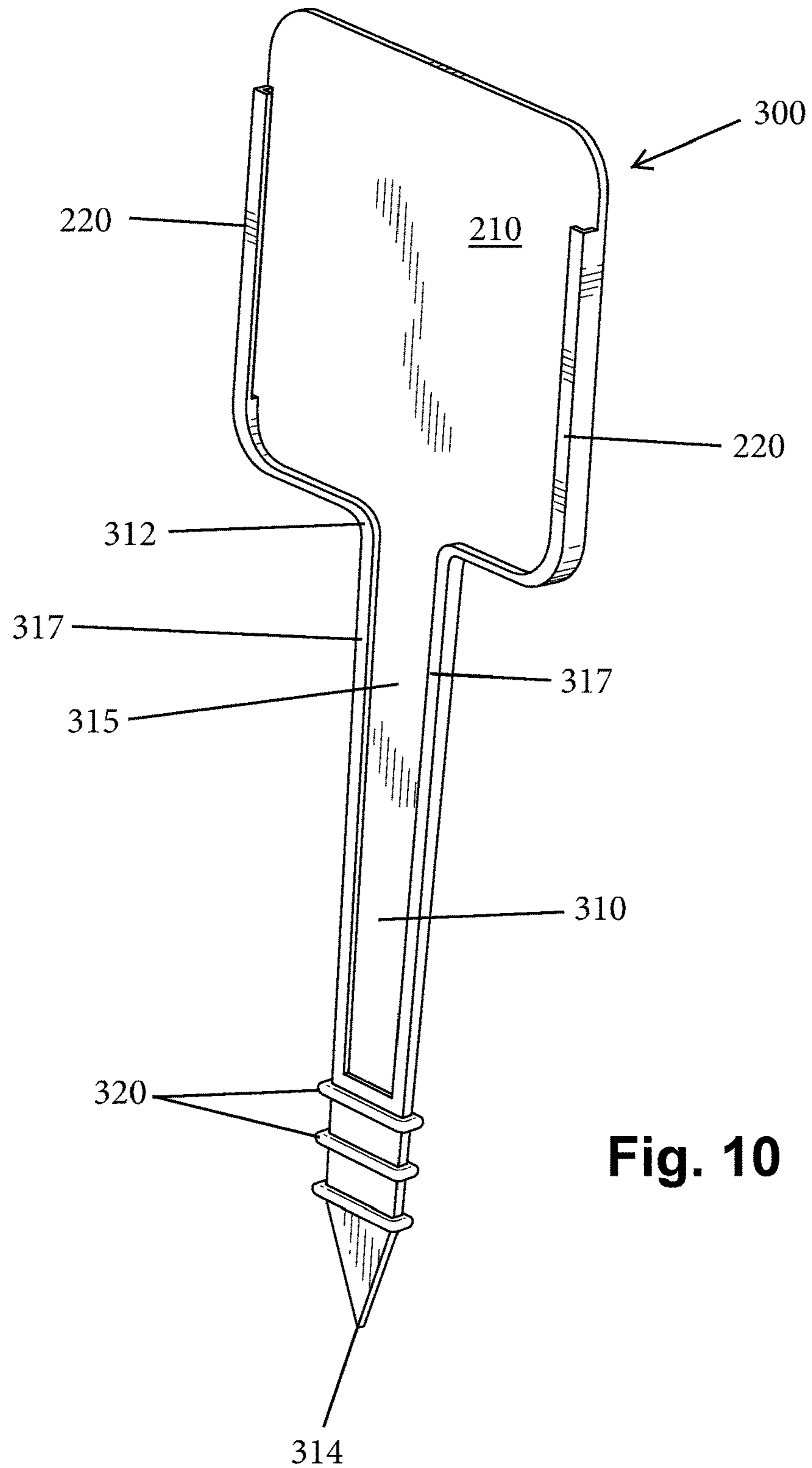

Fig. 10

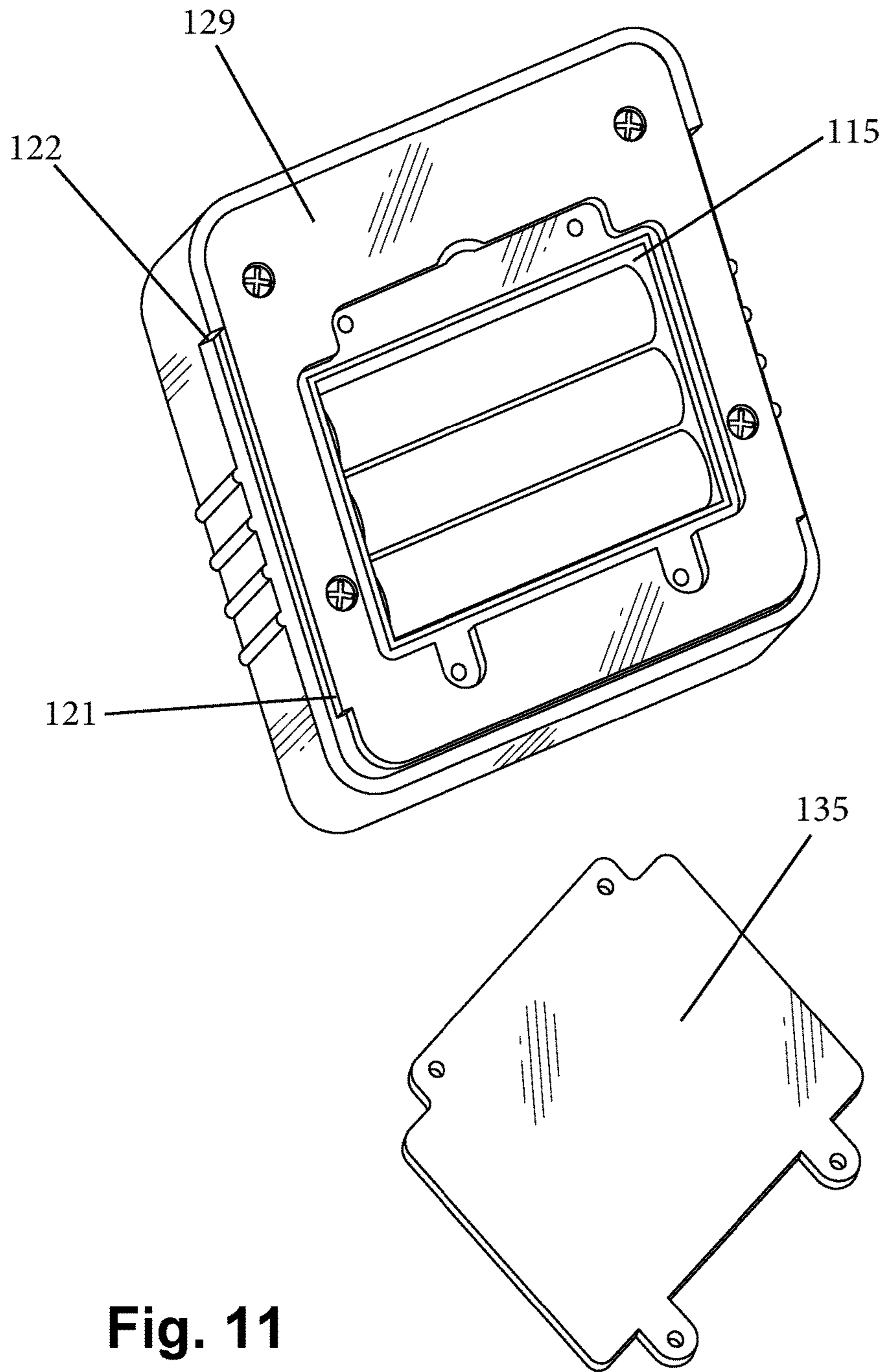

Fig. 11

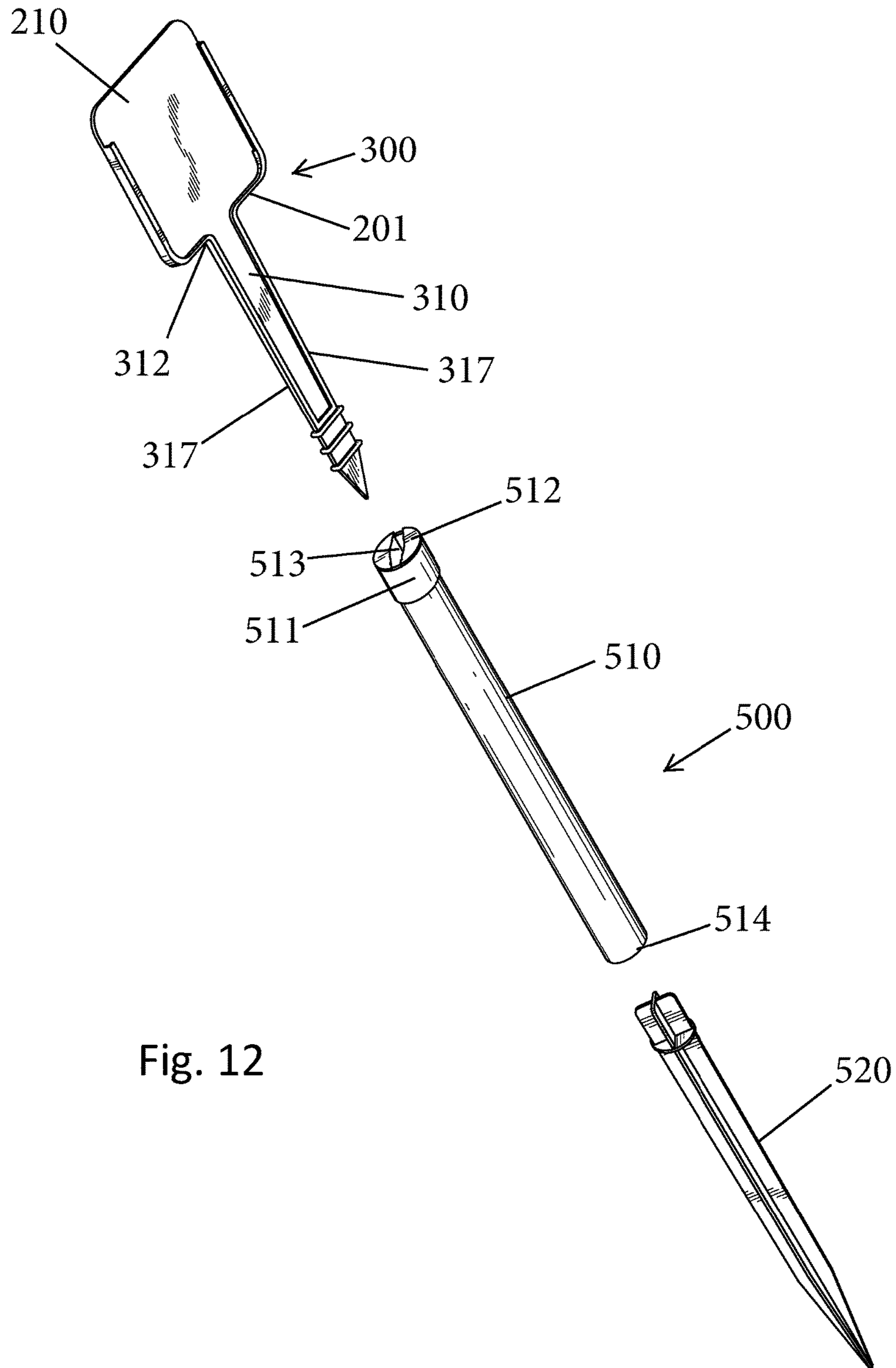

Fig. 12

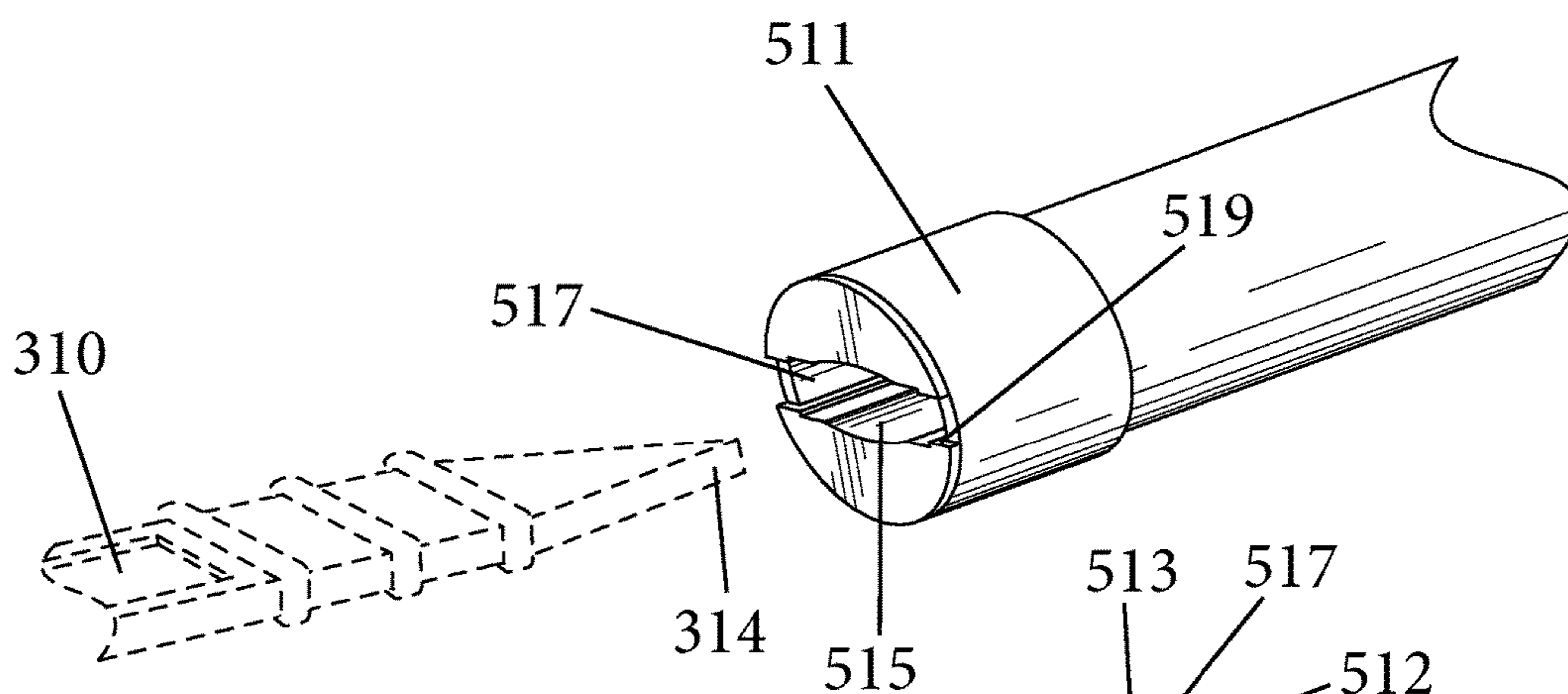

Fig. 14

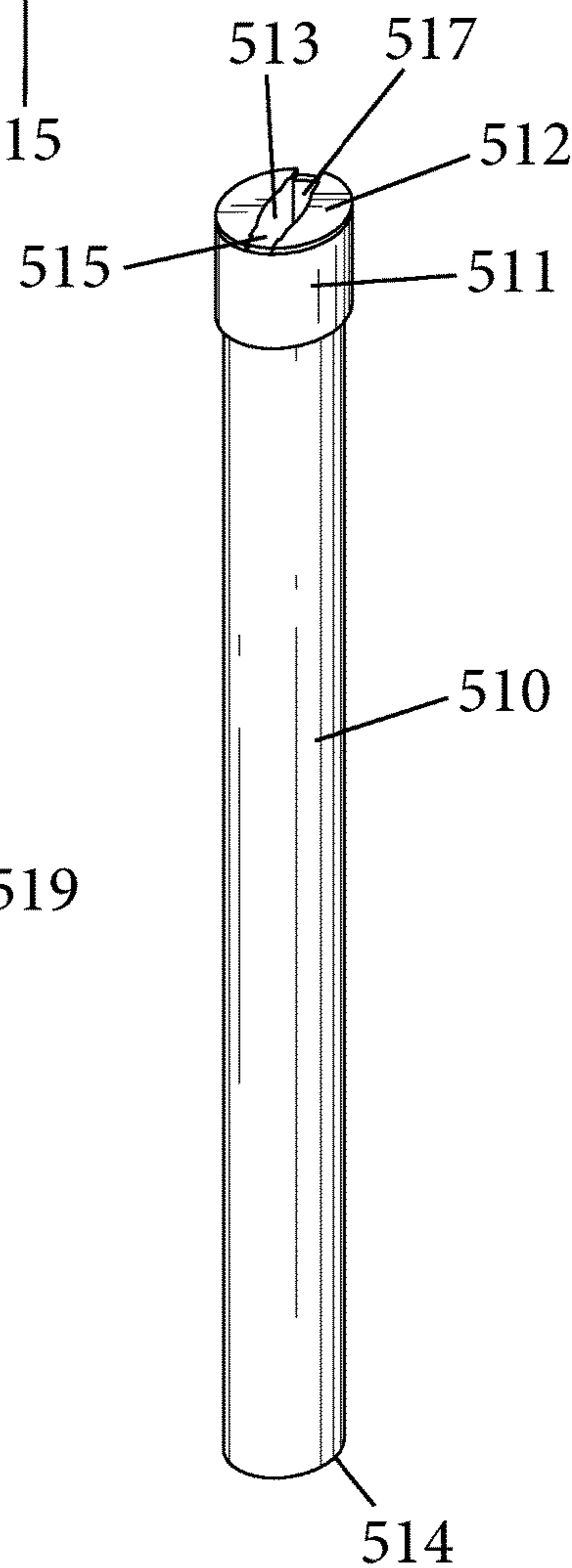

Fig. 13

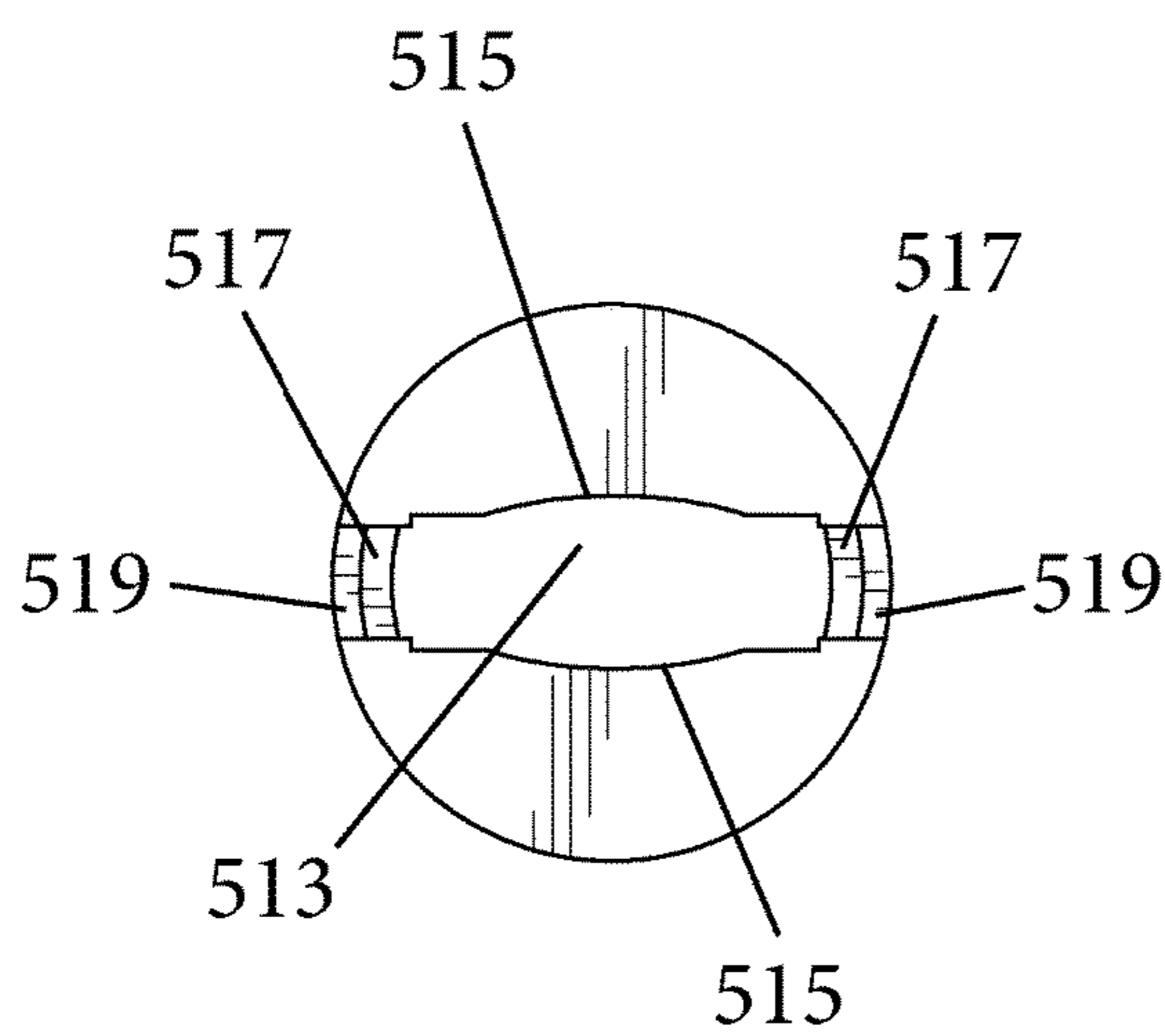

Fig. 15

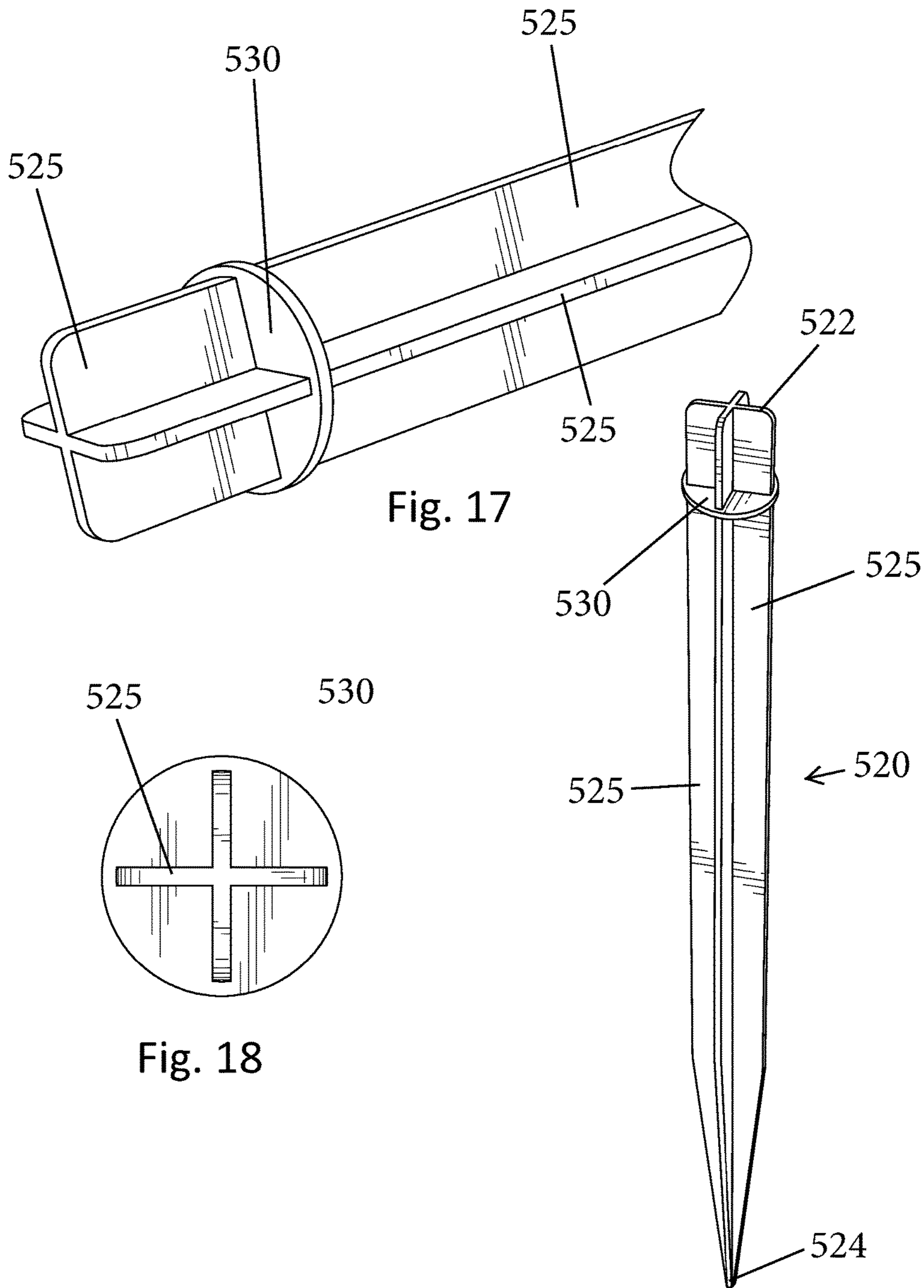

Fig. 17

Fig. 18

Fig. 16

WIRELESS LIGHT ASSEMBLY AND KIT

CROSS-REFERENCE TO RELATED PATENT APPLICATIONS

This application is a continuation-in-part of U.S. Non-Provisional patent application Ser. No. 15/795,717, filed Oct. 27, 2017, the entire contents of which is incorporated by reference herein as if expressly set forth in its respective entirety herein.

TECHNICAL FIELD

The present invention is directed to the field of lighting and more particularly, to a wireless light assembly (a sensor device) and kit that is configured to direct light in a fixed direction and also is configured to be secured to both a support surface, such as a wall or stair, and to a stake for placement in the ground in an outdoor setting or in an indoor garden setting. The light assembly can also be actuated based on sensor information, such as sensing motion or sensing light or the lack thereof (such as a dusk to dawn setting).

BACKGROUND

There are many different types of lights that are commercially available and can be grouped according to their intended uses. For example, there is indoor lighting, outdoor lighting, specialty lighting, etc. Lighting can also be grouped by the power source in that many lights have an electric power source, such as a standard wall outlet; however, there are also many types of lighting that are battery powered.

Another class of lighting is motion activated lighting which can serve both a safety and security function. For example, motion activated lights can be used to guide a person in the middle of the night within the house or can be located outside to guide a person along a pathway or the like.

While there are many wireless motion activated lights on the market what is needed is an improved wireless light assembly/device that can be easily mounted to not only a support surface but also to a garden stake that allows placement within the ground at a select outdoor location.

SUMMARY

In accordance with one embodiment, a wireless light kit includes a wireless light unit that includes a housing having an interior compartment that contains electronics, a power source, and a light source. The wireless light unit also includes: (1) first back plate that is configured to mate with the housing so as to cover at least a portion of the rear face of the housing and provide a mounting surface for mounting to a support surface; and (2) a second back plate that is configured to mate with the housing so as to cover at least a portion of the rear face of the housing, the second back plate having a stake extending outwardly therefrom and configured for insertion into a ground surface for supporting the wireless light unit above the ground surface.

The wireless light unit also includes a stake extender including a first part that has a slot at a first end for receiving the stake and a second part that is configured to be detachably coupled to the first part and has a tapered second end for insertion into the ground surface.

BRIEF DESCRIPTION OF THE DRAWING FIGURES

FIG. 1 is a front, bottom and side perspective view of a wireless light assembly (device) according to one embodiment of the present invention shown in its assembled state;

FIG. 2 is a front and side perspective view of the wireless light assembly;

FIG. 3 shows a housing of the light assembly exploded from an attachable back plate;

FIG. 4 is a top plan view of the light assembly;

FIG. 5 is a bottom plan view of the light assembly;

FIG. 6 is a front elevation view of the light assembly;

FIG. 7 is a rear elevation view of the light assembly;

FIG. 8 is a right side elevation view of the light assembly;

FIG. 9 is a left side elevation view of the light assembly;

FIG. 10 is a perspective view of an alternative attachable back plate including an integral stake element;

FIG. 11 is a rear perspective view of a housing of the wireless light assembly with a battery cover shown exploded therefrom;

FIG. 12 is an exploded perspective view of the stake element of FIG. 10 along with a stake extension;

FIG. 13 is a perspective view of a first part of the stake extension;

FIG. 14 is a partial perspective view of one end of the first part and one end of the stake element;

FIG. 15 is a top plan view of the first part;

FIG. 16 is a perspective view of a second part of the stake extension;

FIG. 17 is a partial perspective view of one end of the second part; and

FIG. 18 is a top plan view of the second part.

DETAILED DESCRIPTION OF CERTAIN EMBODIMENTS

As previously mentioned and with reference to the accompanying drawings, the present invention relates to a wireless light assembly **100** that is configured for attachment to a support surface, such as a wall or a back of a stair, and also can be inserted into the ground when the optional stake type back plate is used as described herein.

The wireless light assembly **100** includes a main unit or housing **110** and an attachable back plate which can either be in the form of a simple back plate **200** as shown in FIG. 3 or can be in the form of a stake type back plate **300** shown in FIG. 10.

The main housing **110** is broadly the structure that houses all of the electronics and the power source. The main housing **110** is thus a sealable structure that includes a hollow interior compartment that contains the electronics and the power source.

In one embodiment, the main housing **110** has a front wall **112**, a top wall **114**, a first side wall **116** and a second side wall **118**. While the main housing **110** is shown as having a generally square shape, it will be appreciated and understood that the main housing **110** can be formed to have any number of different shapes, including but not limited to a rectangle, etc. One or more of the corners of the main housing **110** can be curved.

As shown the front wall **112** can have a curved outer surface or it can be constructed so as to planar. Along rear edges of each of the side walls **116**, **118**, there is a notch or cutout **120** that serves as a guide as described herein. An upper end of the cutout **120** comprises a closed end in that

there is a stop (wall) **122** located thereat. The cutouts **120** have a linear construction and are parallel to one another.

A bottom of the main housing **110** is configured to contain a light source **400** and as shown, the bottom can have a stepped construction in that a bottom wall **123** defines the bottommost portion of the main housing **110** and defines the rear face of the main housing **110**. An inner wall **125** is also formed and is spaced from the bottom wall **123** and can be located parallel thereto. A right angled shoulder can be defined between the inner wall **125** and the bottom wall **123**.

The bottom wall **123** can thus be thought of as defining a ledge **127** since it extends below the inner wall **125**. The ledge **127** can be a planar surface that faces forwardly when the light assembly **100** is oriented vertically, which is a normal in-use position. In this vertical orientation, the inner wall **125** creates an overhang relative to the light source **400** which is located along the ledge **127** and more particularly, an underside of the inner wall **125** is positioned above the light source **400**. For example, one or more lights **400**, such as LEDs, can be provided along the ledge **127** and oriented so as to project light in an outward (forward) direction from the ledge **127**. In the illustrated embodiment, there are a plurality (e.g., three) of light sources (LEDs) **400** that are spaced across the ledge **127**.

It will be understood that inner wall **125** is formed and positioned relative to the light source **400** so as to provide a light deflection function. In particular, as light emanates from the light source **400** (e.g., LEDs), the light waves expand outwardly at different angles as the light waves travel away from the light source **400**. As a result, some of the light waves from each LED contact the inner wall **125** (i.e., the underside thereof) and are deflected in a downward direction since the inner wall **125** acts as a deflector (barrier). This action is desirable since the light assembly **100** is intended to cast light outward to assist a person in seeing the area at which the light assembly **100** is mounted. For example, when the light assembly **100** is mounted along a staircase, it is intended to illuminate one or more stairs, when mounted in a closet, it is intended to illuminate the closet, when mounted in a hallway, it is intended to illuminate the floor, etc.

In this manner each LED **400** is designed to cast light not only forward but also in a downward direction so as to illuminate a greater area around the light assembly **100**.

As shown in FIG. **11**, a rear wall **129** of the main housing **110** can include a removable cover or panel **135** that provides access to a battery compartment **115** to allow for insertion and removal of the batteries **119**. This cover/panel **135** can be attached to the housing **110** using any number of conventional techniques, including but not limited to the use of fasteners, such as screws, etc. The cover/panel **135** can be countersunk so that it is flush to the surrounding sections of the main housing **110** so as to provide a clean, planar rear face of the main housing **110**. A seal member, such as a gasket or O-ring, can be provided as well to establish a seal between the cover/panel **135** and the main housing **110**. Alternatively, the battery compartment **115** can be left open along the rear **129** of the main housing **110** and the back plate **200**, **300** serves to close off and seal the battery compartment.

As mentioned, the hollow interior of the main housing **110** contains the electronics and power source. Exemplary electronics include but are not limited to a processor, such as a printed circuit board (PCB), wiring connecting the PCB to the power source which comprises one or more batteries **119**. One or more switches, such as an on/off switch, are also provided. In addition, the electronics also preferably contain

one or more sensors for actuating the light assembly **100** under select conditions. For example, when a motion sensor **130** is provided, the light assembly **100** will only turn on when motion is sensed in proximity to the motion sensor **130**. The processor can be configured to power the light assembly and thereby illuminate a space for a select period of time (e.g., 30 seconds, 1 minutes, etc.) if no additional motion is sensed besides the initial motion that triggered the operation.

The light assembly **100** can also have a light sensor **140** that detects the light conditions surrounding the unit. The processor can be configured so that the light assembly **100** only operates when certain light conditions are detected by the light sensor **140** and more particularly, when the light sensor **140** detects low light or dark conditions. Thus, even if motion is detected by the motion sensor **130**, if the light sensor **140** detects a threshold amount of light, the light assembly **100** will not operate, thereby conserving its power source since illumination by the light assembly **100** is not required in such observed conditions. The light sensor **140** can be any number of different types of commercially available light sensors, such as a photo cell, etc.

As shown, both the motion sensor **130** and the light sensor **140** are disposed along the front face of the front wall **112** and face outward therefrom.

As mentioned herein, the main housing **110** is configured to mate with two different back plates **200**, **300** and can be supplied to the consumer as a kit in that the consumer is provided with a single package/box that contains a single main housing (unit) **110** along with one back plate **200** (FIG. **3**) and one stake type back plate **300** (FIG. **10**) which can be interchangeably used with the main housing **110**.

As shown in FIG. **3**, the back plate **200** has a rear wall **210** and a partial peripheral side wall **220** that extends along a portion of the rear wall **210**. In the illustrated embodiment, the rear wall **210** has a square shape that is complementary to the shape of the main housing **110**. The peripheral side wall **220** extends substantially along the two sides of the rear wall **210** and completely along the bottom of the rear wall **210** but is absent along the top of the rear wall **210**.

The peripheral side wall **220** has a portion **221** that is perpendicular and integral to the rear wall **210** but also contains a lip **222** that extends inwardly from the portion **221** and thus faces the inside of the rear wall **210**. A right angle is formed between the lip **222** and the portion **221**. The peripheral side wall **220** can be curved in the two lower corners as shown.

The side sections of the peripheral side wall **220** is configured to be received within the guide notches/cutouts **120** so as to complete the side wall of the housing **110**. The back plate **200** is then slid within the guide notches/cutouts **120** until ends **229** of the peripheral side wall **220** contact respective stops **122**. It will be seen from the figures, that the mating between the main housing **110** and the back plate **200** provides a clean finished look since the portions **221** of the peripheral side wall **220** occupies the notches **120** formed along the two opposing sides of the main housing **110**. The top portion of the rear wall **210** that is located above the ends **229** seats against the top portion of the rear of the main housing **110** that is located above the stops **122**.

The rear wall **210** of the back plate **200** thus covers the rear of the main housing **110** and thus represents the rear of the light assembly **100**. To gain access to the electronics and power source, the user simply reverses the steps and slides the back plate **200** off of the main housing **110**. Such action is required to change and replace the batteries.

5

To mount the back plate **200** to a support surface, the back plate **200** can contain holes **201** (FIG. 7) that receives fasteners for attaching the back plate **200** to the support surface. For example, two holes **201** can be formed in the top corners. The fasteners can be in the form of screws, nails, etc. that serve to secure the back plate **200** to the support surface.

Alternatively, along the rear face of the back plate **200** one or more adhesive pads can be provided to allow attachment of the back plate **200** to a support surface, such as a wall. The adhesive pad(s) can be a double sided pad in that a first layer of adhesive serves to attach the pad to the rear face of the back plate **200** and a second layer of adhesive has a removable release cover and is designed for being brought into contact with the support surface for attaching the back plate **200** to the support surface. Since the main housing **110** can easily be separated from the back plate **200**, the back plate **200** remains in the mounted position on the support surface when the main housing **110** needs to be removed, such as for battery replacement.

FIG. 10 illustrate the alternative back plate construction and in particular, illustrate the stake type back plate **300**. The stake type back plate **300** is very similar to the back plate and in fact the back plate **200** forms part of the stake type back plate **300** and therefore, like elements are numbered alike in the drawings. The stake type back plate **300** further includes a stake **310** that extends outwardly (downwardly) from a bottom edge **201** of the back plate **200**. More specifically, the stake **310** extends outwardly from the rear wall **210** of the back plate **200** and is preferably integrally formed therewith.

As shown, the stake **310** is an elongate structure that has a first end **312** that attached to rear wall **210** and an opposing second end **314** that is a free end. The stake **310** can have a tapered construction in that there can be a slight inward taper in the direction toward the second end **314**. This facilitates in driving the stake **310** into the ground.

The second end **314** is preferably a pointed end to facilitate driving the stake **310** into the ground. The stake **310** also can include a fluid channel **315** that is in the form of a recessed channel between extends longitudinally along the stake body. The recessed channel **315** is defined between two raised side edges **317**. The recessed channel **315** is intended to allow water to drain so water does not pool behind the main light unit and damage the electronics. As shown, the recessed channel **315** communicates with the rear wall of the black plate portion against which the housing **110** seats and thus any water that may collect between the housing **110** and the back plate portion will flow by gravity into the recessed channel **315** and then flow down to the ground away from the electronics.

The stake **310** has a tapered construction and in particular, the stake **310** has an inward taper in the direction toward the second end **314**. In other words, the width of the stake **310** is greatest at its upper end adjacent the rear wall **210**, while the width is less near the second end **314**.

The stake **310** can further include one or more and preferably, a plurality of ribs **320** formed along the outer surface of the stake **310**. Each rib **320** can be a continuous structure that extends along the front, sides, and rear of the stake **310**. When plural ribs **320** are provided, they are spaced from one another. The ribs **320** serve to providing the stake **310** with better gripping properties and allow the stake **310** to be better retained within the ground.

It will be appreciated that in the stake type back plate **300**, the adhesive pad can be eliminated along the rear face of the back plate **200**.

6

As mentioned, the aforementioned parts can be provided to the consumer as a kit that allows the consumer to have the choice of using the main housing **110** with either the standard back plate **200** or the stake type back plate **300**. This provides great versatility to the user.

It will be appreciated that the overhang (the inner wall **125**) adjacent the ledge **127** can contain a layer of material, such as a strip of material that serves to reflect the light waves. For example, a reflective plastic strip can be provided at this location and since it faces downward in use, it is not readily visible in many mounting positions of the light assembly **100**.

Stake Extension

In accordance with the present invention, in some situations a longer stake is needed for suspending the light assembly **100** at the desired height relative to the ground surface. As shown in FIGS. 12-18, a stake extender (stake extension) **500** is provided for increasing the overall length of the stake that is insertable into the ground and suspends the light assembly **100**. The stake extender **500** is formed of a first part **510** and a second part **520**. The first part **510** is an elongated extender body having an open first end **512** and an opposing second end **514**. The first part **510** can thus be a tubular structure and can come in any number of different shapes and sizes (e.g., lengths).

At or near the first end **512** of the first part **510**, the body of the first part **510** can have an enlarged section generally shown at **511**. In the case of cylindrical shaped tube for the first part **510**, the enlarged section **511** has an annular shape. This enlarged section **511** can assist the user in separating the extender **500** from the light assembly and also serves to receive and capture the stake **310**. As shown in the figures, the elongated stake **310** generally has a rectangular shape. The enlarged section **511** has a slot **513** formed therein. The slot **513** is complementary to the cross-section of the elongated stake **310** and therefore, the slot **513** can be generally rectangular shaped. The slot **513** is defined by a pair of opposing side walls **515** and a pair of opposing end walls **517**. The slot **513** has a width of about X units (a first value). As mentioned before, the stake **310** has a variable width in that it has a greater width at its top portion and in particular, the maximum width of the stake **310** near the rear wall **210** is about Y units (a second value). In accordance with the illustrated embodiment, the width Y is greater than the width X. As a result, when the second end **314** of the stake **310** is inserted into the slot **513**, there is sufficient room for insertion since the width Z of the stake **310** near the second end **314** is less than the width X of the slot **513** (and less than the width Y of the stake at an upper location proximate rear wall **210**). When the stake **300** is continuously inserted into the interior of the first part **510**, the side edges **317** of the stake **310** come into contact with the end walls **517**. Continued advancement of the stake **310** results in a friction fit being formed between the stake **310** and the enlarged section **511** due to the wider portion of the stake **310** being driven into contact with the ends walls **517**. This friction fit results in the secure attachment of the stake **310** to the first part **510**.

To remove the stake **310** from the stake extender **500**, the stake **310** is simply moved in an upward direction away from the stake extender **500**. As the stake **310** moves in this direction, the contact between the side edges **317** of the stake **310** and the end walls **517** lessens and the stake **310** can rock laterally and can easily disengage from the stake extender **500**.

In yet another aspect, a top surface of the enlarged section **511** has a pair of recessed portions **519** that are located at the two opposing ends of the slot **513** and more specifically, are

located at the tops of the end walls **517**. When fully inserted, the bottom edge **201** of the rear wall **210** seats within the recessed portions **519**. The two recessed portions **519** thus provide a means for making sure that the stake **300** sits well inside of the stake extender **500** and does not move within the interior of the stake extender **500**. When the bottom edge **201** seats within the recessed portions **519**, the stake **310** is frictionally held within the first part **510** and is motion restricted since the bottom edge **201** is nested within the recessed portions **519**.

The second part **520** has a first end **522** and an opposing second end **524**. The second part **520** is formed as a stake that can be driven into the ground. The second part **520** can be defined by a plurality of blades or ribs **525** that can be arranged relative to one another. For example, the illustrated second part **520** has an X-shape that is defined by four blades **525** that are arranged at 90 degrees relative to one another.

The second part **520** has a tapered construction in that it can be inwardly tapered toward the second end **524** so as to create a pointed tip that is configured to more easily enter the ground. Near the first end **522**, the second part **520** has a flange **530** that protrudes radially outward from the body of the second part **520**. The flange **530** can thus be annular shaped. As discussed herein, the flange **530** can act as a stop for limiting travel of the second end **514** of the first part **510** relative to the second part **520**.

As shown in FIG. **13**, the first part **510** and second part **520** are jointed together by inserting the second end **514** onto the first end **522** of the second part **520** until the second end **514** makes contact with and seats against the flange **530**.

The first part **510** and second part **520** can easily be disengaged from one another by pulling the two parts **510**, **520** apart from one another.

The stake holder extension thus provides a means for extending the overall length of the stake in a manner in which the light assembly is still securely held in place. The structure of the stake holder extension is designed to securely hold the light assembly and limit its rocking motion (lateral movement) due to the recessed nature of the bottom edge **201** of the rear wall **210**.

Notably, the figures and examples above are not meant to limit the scope of the present invention to a single embodiment, as other embodiments are possible by way of interchange of some or all of the described or illustrated elements. Moreover, where certain elements of the present invention can be partially or fully implemented using known components, only those portions of such known components that are necessary for an understanding of the present invention are described, and detailed descriptions of other portions of such known components are omitted so as not to obscure the invention. In the present specification, an embodiment showing a singular component should not necessarily be limited to other embodiments including a plurality of the same component, and vice-versa, unless explicitly stated otherwise herein. Moreover, applicants do not intend for any term in the specification or claims to be ascribed an uncommon or special meaning unless explicitly set forth as such. Further, the present invention encompasses present and future known equivalents to the known components referred to herein by way of illustration.

The foregoing description of the specific embodiments will so fully reveal the general nature of the invention that others can, by applying knowledge within the skill of the relevant art(s) (including the contents of the documents cited and incorporated by reference herein), readily modify and/or adapt for various applications such specific embodiments, without undue experimentation, without departing from the

general concept of the present invention. Such adaptations and modifications are therefore intended to be within the meaning and range of equivalents of the disclosed embodiments, based on the teaching and guidance presented herein.

It is to be understood that the phraseology or terminology herein is for the purpose of description and not of limitation, such that the terminology or phraseology of the present specification is to be interpreted by the skilled artisan in light of the teachings and guidance presented herein, in combination with the knowledge of one skilled in the relevant art(s).

While various embodiments of the present invention have been described above, it should be understood that they have been presented by way of example, and not limitation. It would be apparent to one skilled in the relevant art(s) that various changes in form and detail could be made therein without departing from the spirit and scope of the invention. Thus, the present invention should not be limited by any of the above-described exemplary embodiments, but should be defined only in accordance with the following claims and their equivalents.

What is claimed:

1. A wireless light kit comprising:

a wireless light unit including:

a housing having an interior compartment that contains electronics, a power source, and a light source;

a first back plate that is configured to mate with the housing so as to cover at least a portion of the rear face of the housing and provide a mounting surface for mounting to a support surface; and

a second back plate that is configured to mate with the housing so as to cover at least a portion of the rear face of the housing, the second back plate having a stake extending outwardly therefrom and configured for insertion into a ground surface for supporting the wireless light unit above the ground surface; and

a stake extender including a first part that has a slot at a first end for receiving the stake and a second part that is configured to be detachably coupled to the first part and has a tapered second end for insertion into the ground surface.

2. The wireless light kit of claim 1, wherein along a bottom of the housing, a ledge is formed and when the housing is oriented in a vertical position, there is an inner wall adjacent to and overhanging the ledge and wherein the light source is positioned along the ledge and configured to emit light in an outward direction from the ledge, wherein the inner wall is positioned and constructed so as to deflect the emitted light in a downward direction that is away from the inner wall.

3. The wireless light kit of claim 1, wherein the stake has a tapered construction in that a top end of the stake has a greater width than a bottom end of the stake to allow a friction fit between the stake and the first part when the top end of the stake is positioned in the slot in contact with end walls defining the slot.

4. The wireless light kit of claim 3, wherein the slot is generally rectangular shaped and the stake has a generally rectangular cross-section.

5. The wireless light kit of claim 1, wherein the first part has an enlarged section at the first end, the slot being formed in a top surface of the enlarged section, the top surface having a pair of recesses formed at ends of the slot and configured to receive a bottom edge of the housing such that the bottom edge lies below the top surface of the enlarged section.

9

6. The wireless light kit of claim 1, wherein the second part has a plurality of longitudinal rails that are arranged at an angle relative to one another and includes a flange that extends radially beyond outer edges of the longitudinal rails, wherein when the first part and a first end of the second part is inserted into a second end of the first part until the second end seats against the flange.

7. The wireless light kit of claim 1, wherein the first part comprises a hollow tube.

8. The wireless light kit of claim 5, wherein the enlarged section is cylindrically shaped having a diameter greater than a diameter of a lower tubular portion of the first part.

9. The wireless light kit of claim 2, wherein the ledge extends from a first bottom corner to an opposing second bottom corner of the housing.

10. The wireless light kit of claim 2, wherein the inner wall is formed at a right angle relative to the ledge.

10

11. The wireless light kit of claim 2, wherein the inner wall extends across an entire width of the ledge.

12. The wireless light kit of claim 2, wherein the light source comprises at least one LED that is disposed within the ledge, the at least one LED being positioned and configured such that emitted light rays thereof contact and are deflected downward by the inner wall.

13. The wireless light kit of claim 12, wherein there is a plurality of LEDs that are spaced across and along the ledge.

14. The wireless light kit of claim 1, wherein the stake is inwardly tapered in a direction toward a pointed free end thereof and includes at least one rib formed along an outer surface of the stake.

15. The wireless light kit of claim 14, wherein a width of the at least one rib is less than a maximum width of the stake at an upper end of the stake.

* * * * *