

US010283144B2

(12) **United States Patent**
Biskeborn et al.

(10) **Patent No.:** **US 10,283,144 B2**
(45) **Date of Patent:** **May 7, 2019**

(54) **TAPE HEAD HAVING A PORTION OF A BEARING SURFACE SLOT THAT DEFINES A SKIVING EDGE**

(58) **Field of Classification Search**
None
See application file for complete search history.

(71) Applicant: **International Business Machines Corporation**, Armonk, NY (US)

(56) **References Cited**

(72) Inventors: **Robert G. Biskeborn**, Hollister, CA (US); **Calvin S. Lo**, Saratoga, CA (US)

U.S. PATENT DOCUMENTS

(73) Assignee: **International Business Machines Corporation**, Armonk, NY (US)

4,624,048 A	11/1986	Hinkel et al.	
5,124,866 A	6/1992	Rothermel	
5,718,035 A	2/1998	Yamanaka et al.	
5,774,306 A	6/1998	Wang et al.	
6,081,991 A	7/2000	Tsunoda et al.	
7,082,013 B2	7/2006	Deshpande et al.	
7,167,339 B2	1/2007	Biskeborn et al.	
7,248,438 B2 *	7/2007	Biskeborn	G11B 5/00826 360/129
7,274,536 B2	9/2007	Deshpande et al.	

(Continued)

(*) Notice: Subject to any disclaimer, the term of this patent is extended or adjusted under 35 U.S.C. 154(b) by 0 days.

(21) Appl. No.: **15/488,272**

FOREIGN PATENT DOCUMENTS

(22) Filed: **Apr. 14, 2017**

JP	H11214588 A	8/1999	
JP	2006054044 A *	2/2006 G11B 5/3163

(65) **Prior Publication Data**

US 2018/0102138 A1 Apr. 12, 2018

OTHER PUBLICATIONS

Supplemental Notice of Allowance from U.S. Appl. No. 15/289,030, dated Jun. 5, 2017.

Related U.S. Application Data

(Continued)

(62) Division of application No. 15/289,002, filed on Oct. 7, 2016, now Pat. No. 9,704,514.

Primary Examiner — William J Klimowicz
(74) *Attorney, Agent, or Firm* — Zilka-Kotab, P.C.

(51) **Int. Cl.**
G11B 5/187 (2006.01)
G11B 5/31 (2006.01)
G11B 5/008 (2006.01)
G11B 5/60 (2006.01)

(57) **ABSTRACT**
An apparatus according to one embodiment includes a substrate, and a thin film layer on the substrate having transducers therein. A portion of a bearing surface slot extends along the substrate, the portion of the bearing surface slot defining a skiving edge. A length of a tape bearing surface between the substrate and the skiving edge is in a range of about 7 to about 30 microns.

(52) **U.S. Cl.**
CPC **G11B 5/1871** (2013.01); **G11B 5/00813** (2013.01); **G11B 5/3109** (2013.01); **G11B 5/3169** (2013.01); **G11B 5/3173** (2013.01); **G11B 5/6082** (2013.01)

13 Claims, 11 Drawing Sheets

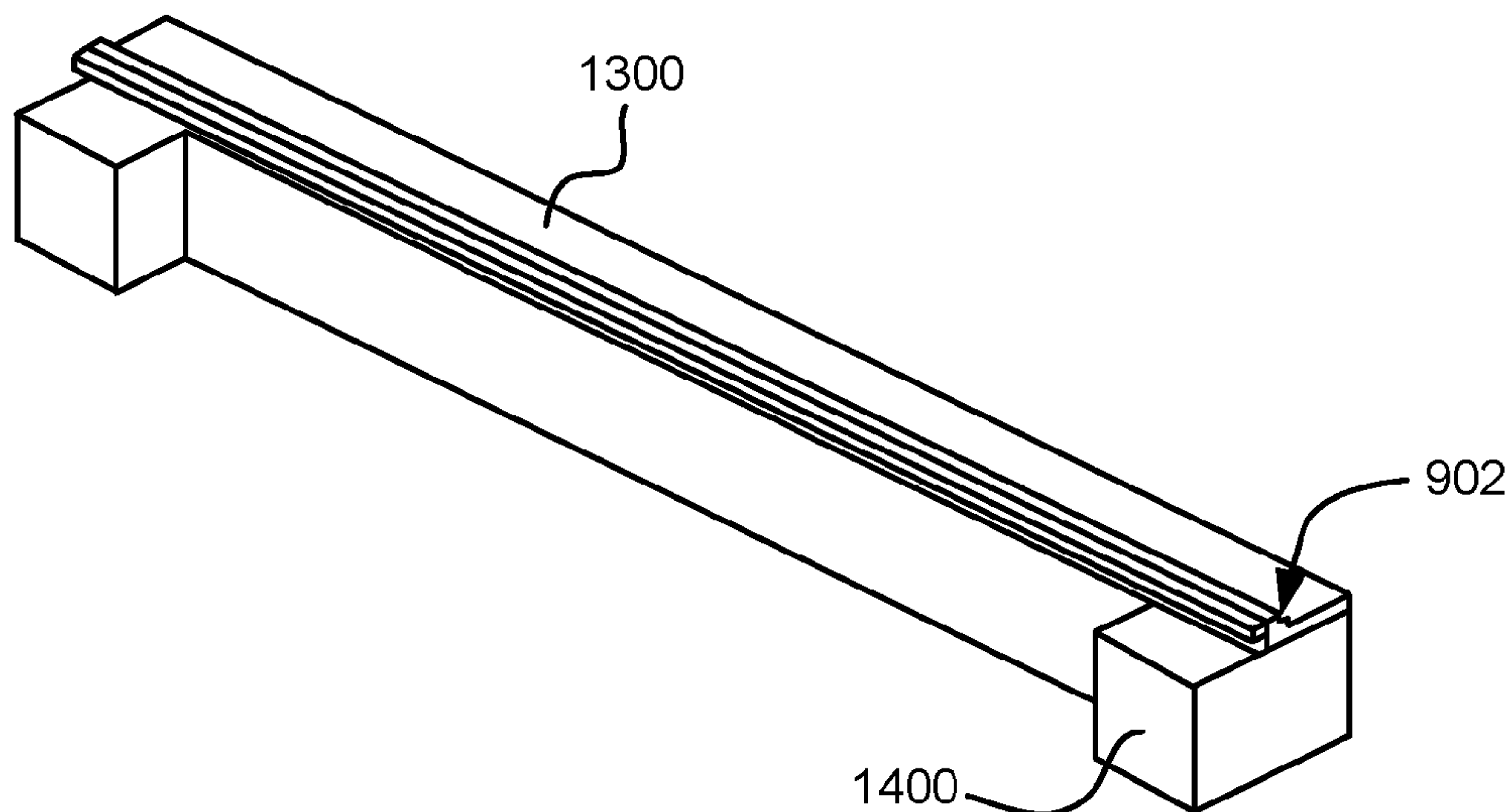

(56)

References Cited

U.S. PATENT DOCUMENTS

7,382,581 B2 * 6/2008 Biskeborn G11B 5/105
360/121

7,492,552 B2 2/2009 Deshpande et al.

7,660,072 B2 2/2010 Biskeborn et al.

8,351,162 B2 1/2013 Etoh et al.

8,675,310 B2 3/2014 Biskeborn et al.

8,917,476 B2 * 12/2014 Holmberg G11B 5/00813
360/90

9,638,614 B2 5/2017 Biskeborn et al.

9,704,514 B1 7/2017 Biskeborn et al.

9,711,170 B1 7/2017 Biskeborn et al.

9,779,766 B1 10/2017 Biskeborn et al.

9,799,355 B1 10/2017 Biskeborn et al.

9,837,104 B1 * 12/2017 Biskeborn G11B 5/255

9,928,855 B1 * 3/2018 Biskeborn G11B 5/187

10,204,647 B2 2/2019 Biskeborn et al.

2002/0094758 A1 7/2002 Reiley et al.

2003/0076631 A1 4/2003 Torline et al.

2004/0223261 A1 11/2004 Deshpande et al.

2005/0122631 A1 6/2005 Biskeborn et al.

2005/0128638 A1 6/2005 Koeppe et al.

2005/0128640 A1 * 6/2005 Biskeborn G11B 5/00826
360/129

2005/0168874 A1 8/2005 Biskeborn et al.

2006/0292968 A1 12/2006 Fujii

2007/0047141 A1 3/2007 Biskeborn et al.

2007/0062028 A1 * 3/2007 Biskeborn G11B 5/39
29/603.09

2008/0049358 A1 2/2008 Biskeborn et al.

2009/0059421 A1 * 3/2009 Biskeborn G11B 5/102
360/110

2009/0201613 A1 * 8/2009 Biskeborn G11B 5/00826
360/313

2010/0134929 A1 * 6/2010 Ito G11B 5/0083
360/313

2012/0300338 A1 * 11/2012 Biskeborn G11B 5/00826
360/75

2014/0087089 A1 3/2014 Biskeborn et al.

2016/0232936 A1 * 8/2016 Poorman G11B 15/60

2018/0108371 A1 4/2018 Biskeborn et al.

2018/0108372 A1 4/2018 Biskeborn et al.

OTHER PUBLICATIONS

Supplemental Notice of Allowance from U.S. Appl. No. 15/333,034, dated Jun. 7, 2017.

Supplemental Notice of Allowance from U.S. Appl. No. 15/289,002, dated Jun. 8, 2017.

Notice of Allowance from U.S. Appl. No. 15/297,002, dated Jun. 16, 2017.

Supplemental Notice of Allowance from U.S. Appl. No. 15/289,002, dated May 9, 2017.

Supplemental Notice of Allowance from U.S. Appl. No. 15/289,030, dated May 9, 2017.

Notice of Allowance from U.S. Appl. No. 15/333,034, dated May 24, 2017.

Supplemental Notice of Allowance from U.S. Appl. No. 15/333,034, dated Jul. 25, 2017.

Supplemental Notice of Allowance from U.S. Appl. No. 15/297,002, dated Aug. 1, 2017.

Biskeborn et al., U.S. Appl. No. 15/289,002, filed Oct. 7, 2016.

Biskeborn et al., U.S. Appl. No. 15/289,030, filed Oct. 7, 2016.

Biskeborn et al., U.S. Appl. No. 15/297,002, filed Oct. 18, 2016.

Biskeborn et al., U.S. Appl. No. 15/333,034, filed Oct. 24, 2016.

Biskeborn et al., U.S. Appl. No. 15/369,651, filed Dec. 5, 2016.

Restriction Requirement from U.S. Appl. No. 15/289,030, dated Dec. 6, 2016.

Restriction Requirement from U.S. Appl. No. 15/289,002, dated Dec. 7, 2016.

Restriction Requirement from U.S. Appl. No. 15/297,002, dated Dec. 7, 2016.

Restriction Requirement from U.S. Appl. No. 15/333,034, dated Jan. 5, 2017.

Non-Final Office Action from U.S. Appl. No. 15/297,002, dated Feb. 27, 2017.

Notice of Allowance from U.S. Appl. No. 15/289,002, dated Mar. 2, 2017.

Notice of Allowance from U.S. Appl. No. 15/289,030, dated Mar. 10, 2017.

Supplemental Notice of Allowance from U.S. Appl. No. 15/289,030, dated Mar. 27, 2017.

Corrected Notice of Allowance from U.S. Appl. No. 15/289,002, dated Apr. 5, 2017.

Ex Parte Quayle from U.S. Appl. No. 15/333,034, Mar. 30, 2017.

Supplemental Notice of Allowance from U.S. Appl. No. 15/333,034, dated Aug. 25, 2017.

Supplemental Notice of Allowance from U.S. Appl. No. 15/297,002, dated Aug. 31, 2017.

Biskeborn et al., U.S. Appl. No. 15/685,903, filed Aug. 24, 2017.

Biskeborn et al., U.S. Appl. No. 15/685,930, filed Aug. 24, 2017.

Non-Final Office Action from U.S. Appl. No. 15/685,930, dated Apr. 20, 2018.

Non-Final Office Action from U.S. Appl. No. 15/685,903, dated Apr. 9, 2018.

Final Office Action from U.S. Appl. No. 15/685,903, dated Sep. 14, 2018.

Notice of Allowance from U.S. Appl. No. 15/685,930, dated Sep. 21, 2018.

Supplemental Notice of Allowance from U.S. Appl. No. 15/685,930, dated Nov. 15, 2018.

Notice of Allowance from U.S. Appl. No. 15/685,903, dated Dec. 3, 2018.

Supplemental Notice of Allowance from U.S. Appl. No. 15/685,903, dated Jan. 10, 2019.

Supplemental Notice of Allowance from U.S. Appl. No. 15/685,903, dated Feb. 1, 2019.

Biskeborn et al., U.S. Appl. No. 16/271,527, filed Feb. 8, 2019.

* cited by examiner

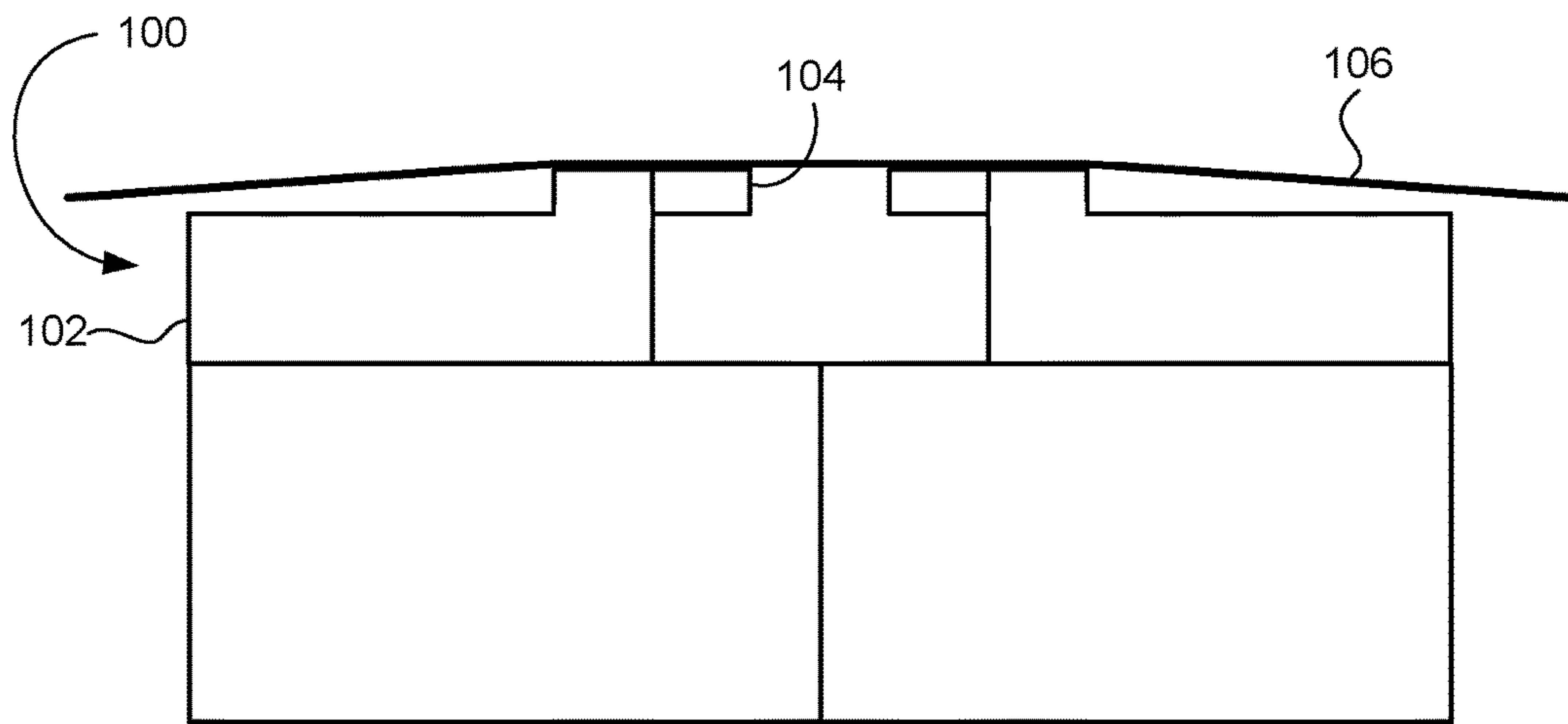

FIG. 1

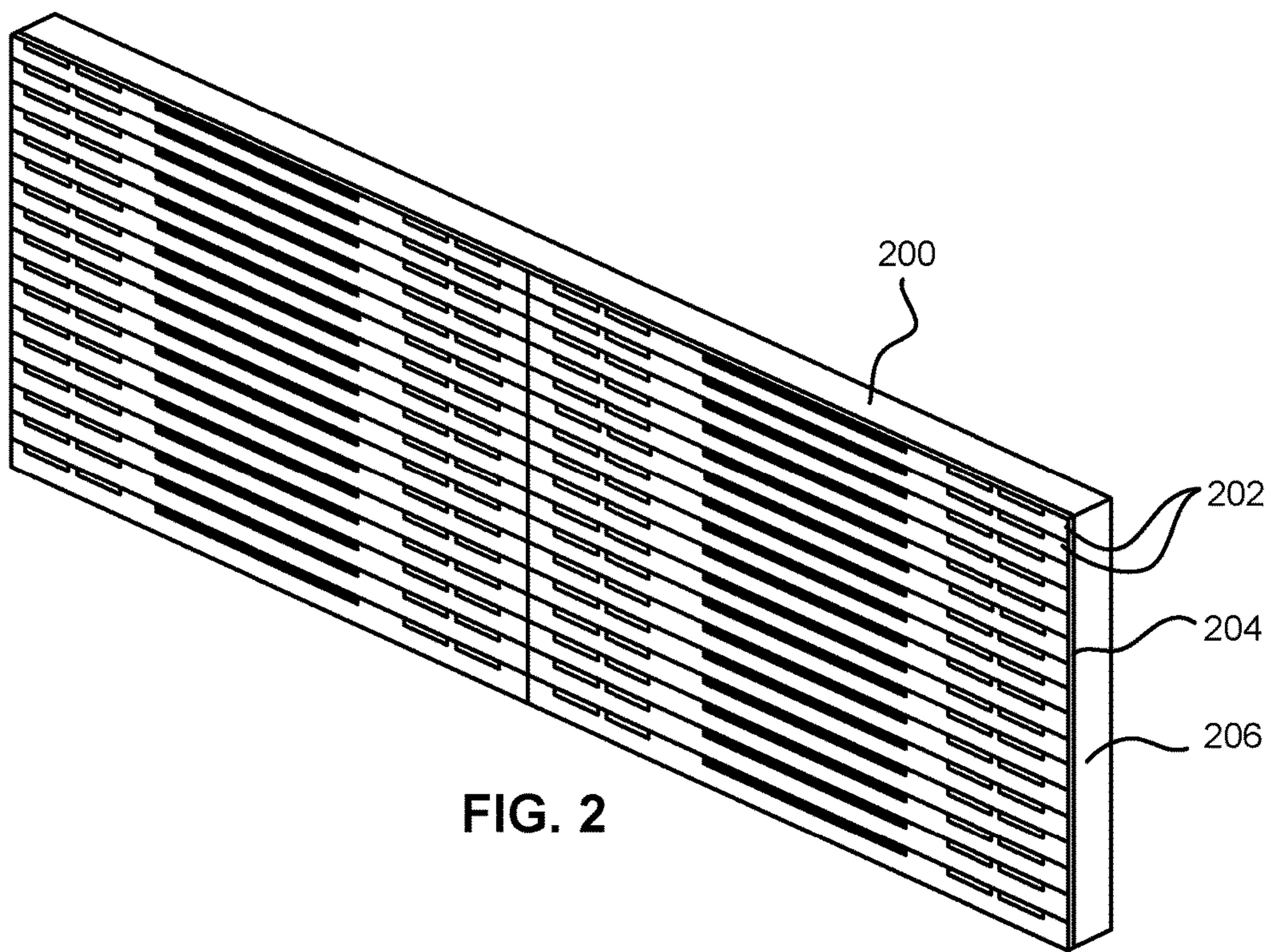
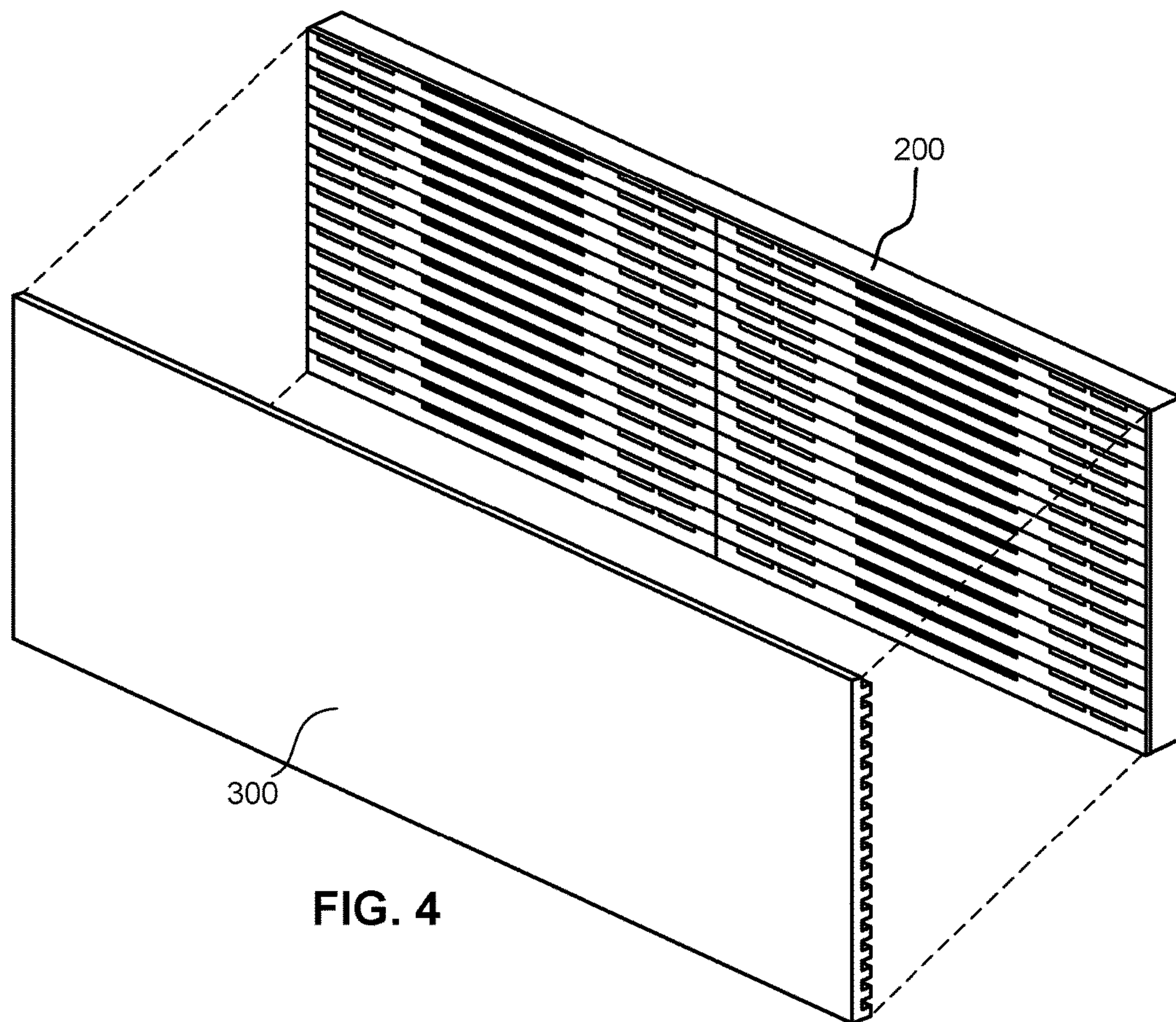
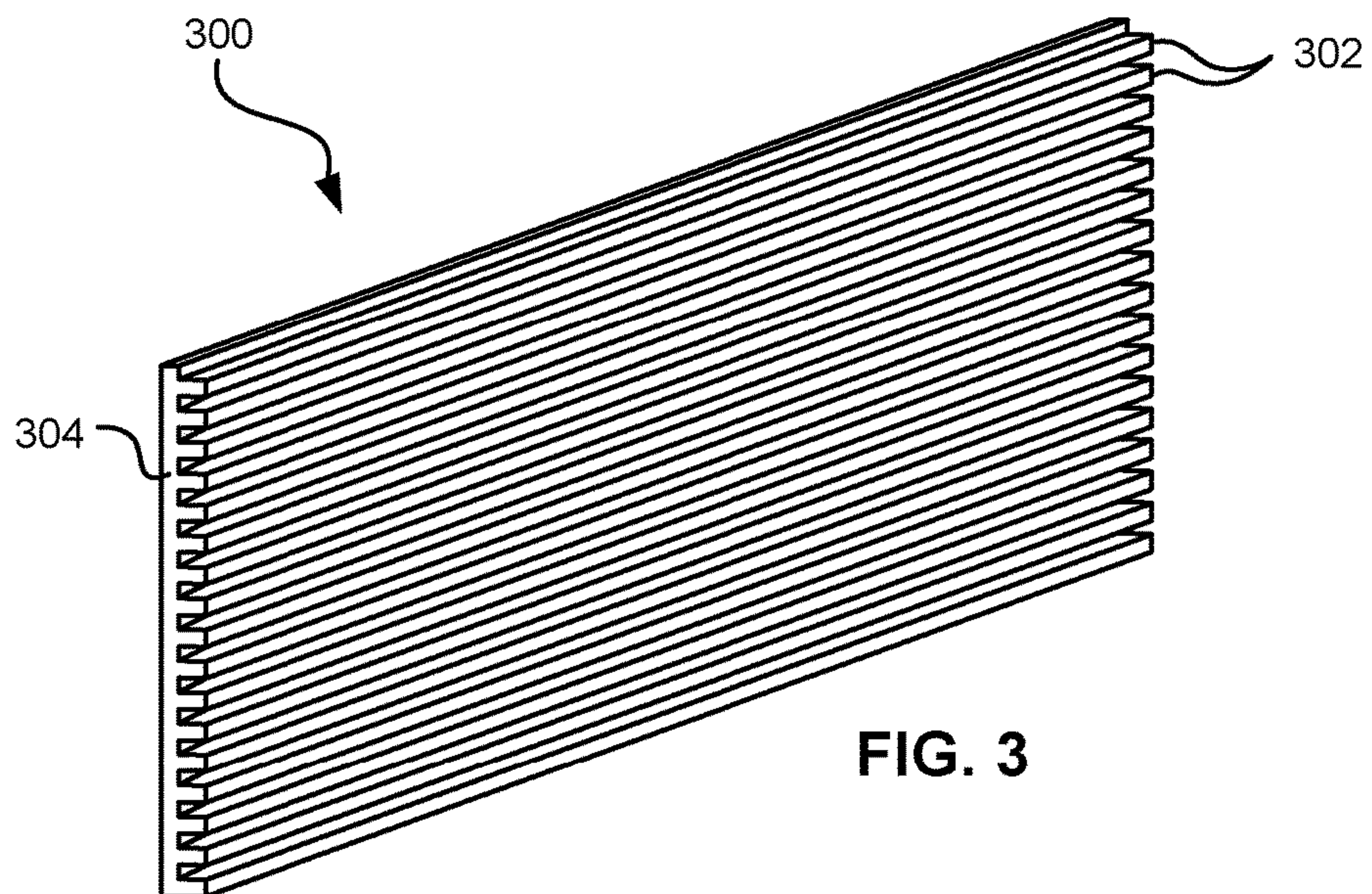

FIG. 2



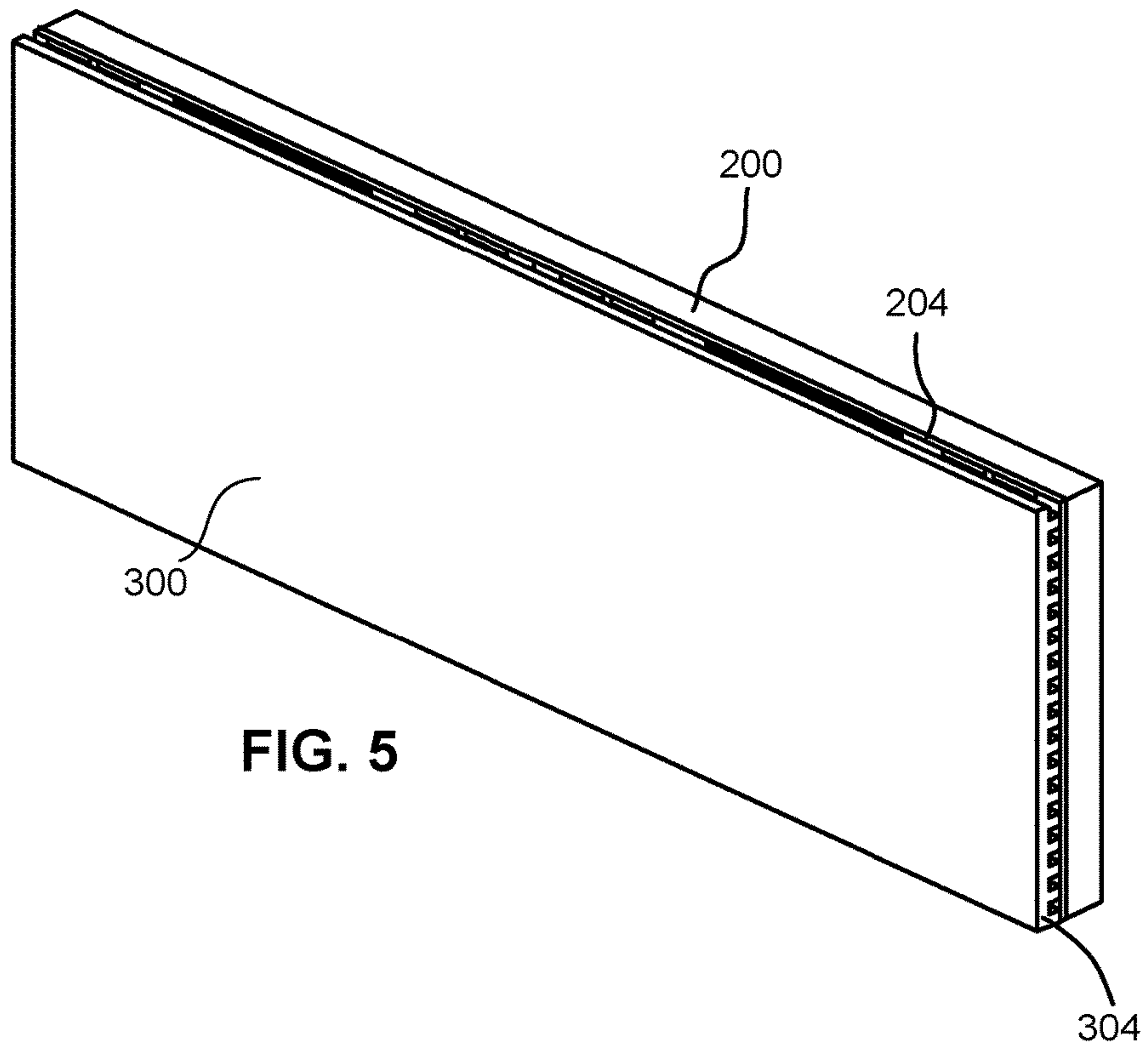

FIG. 5

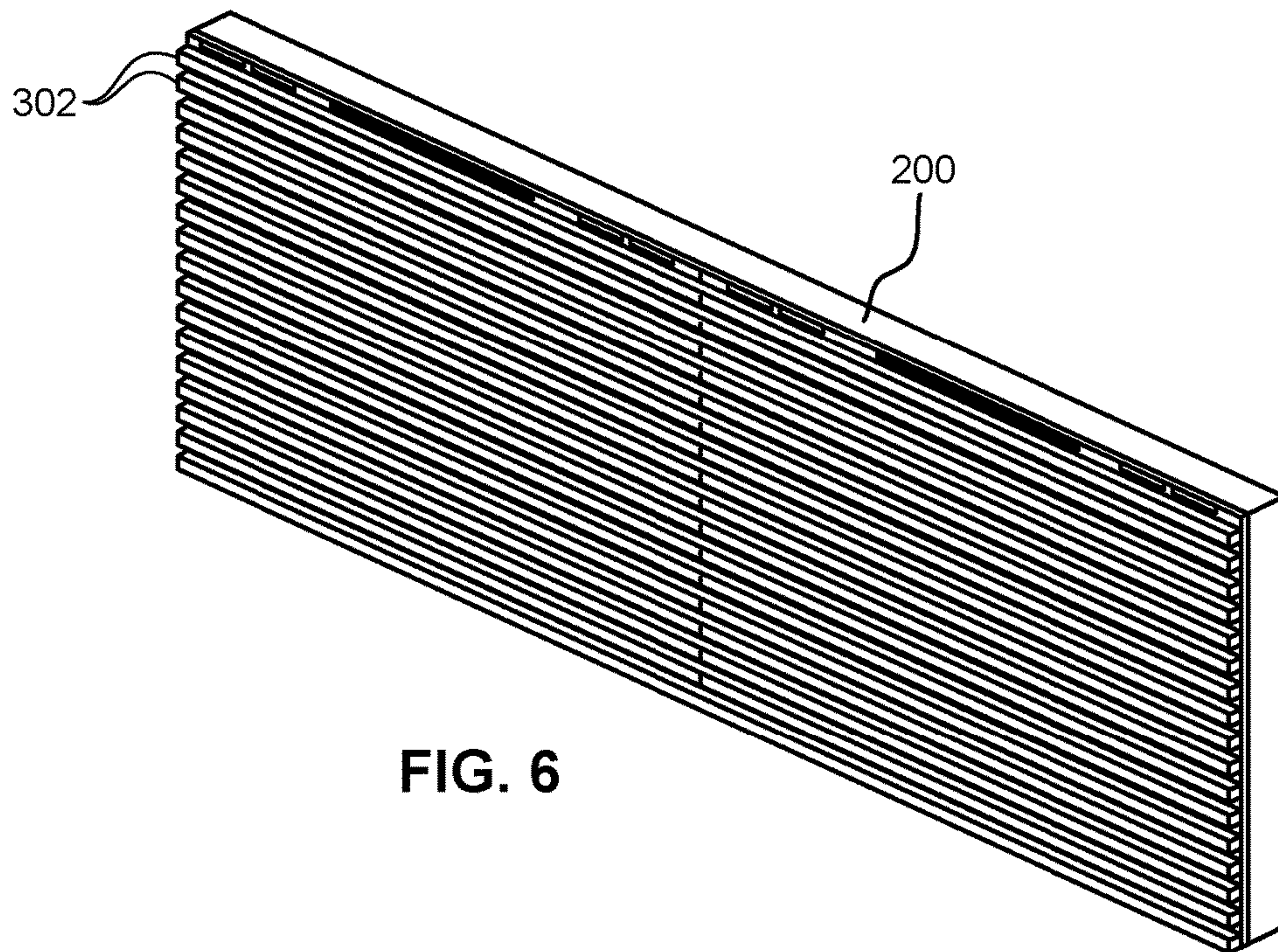

FIG. 6

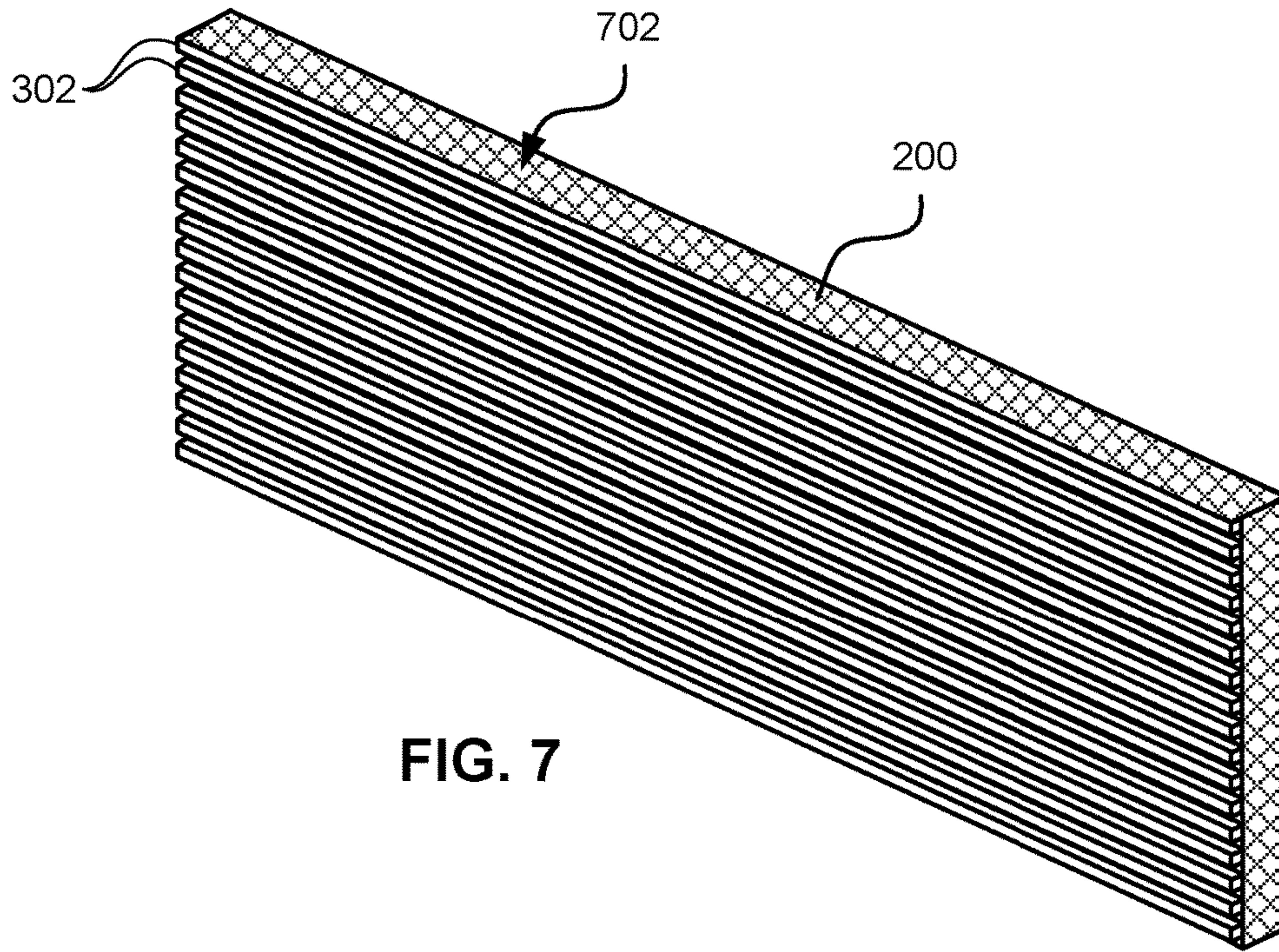

FIG. 7

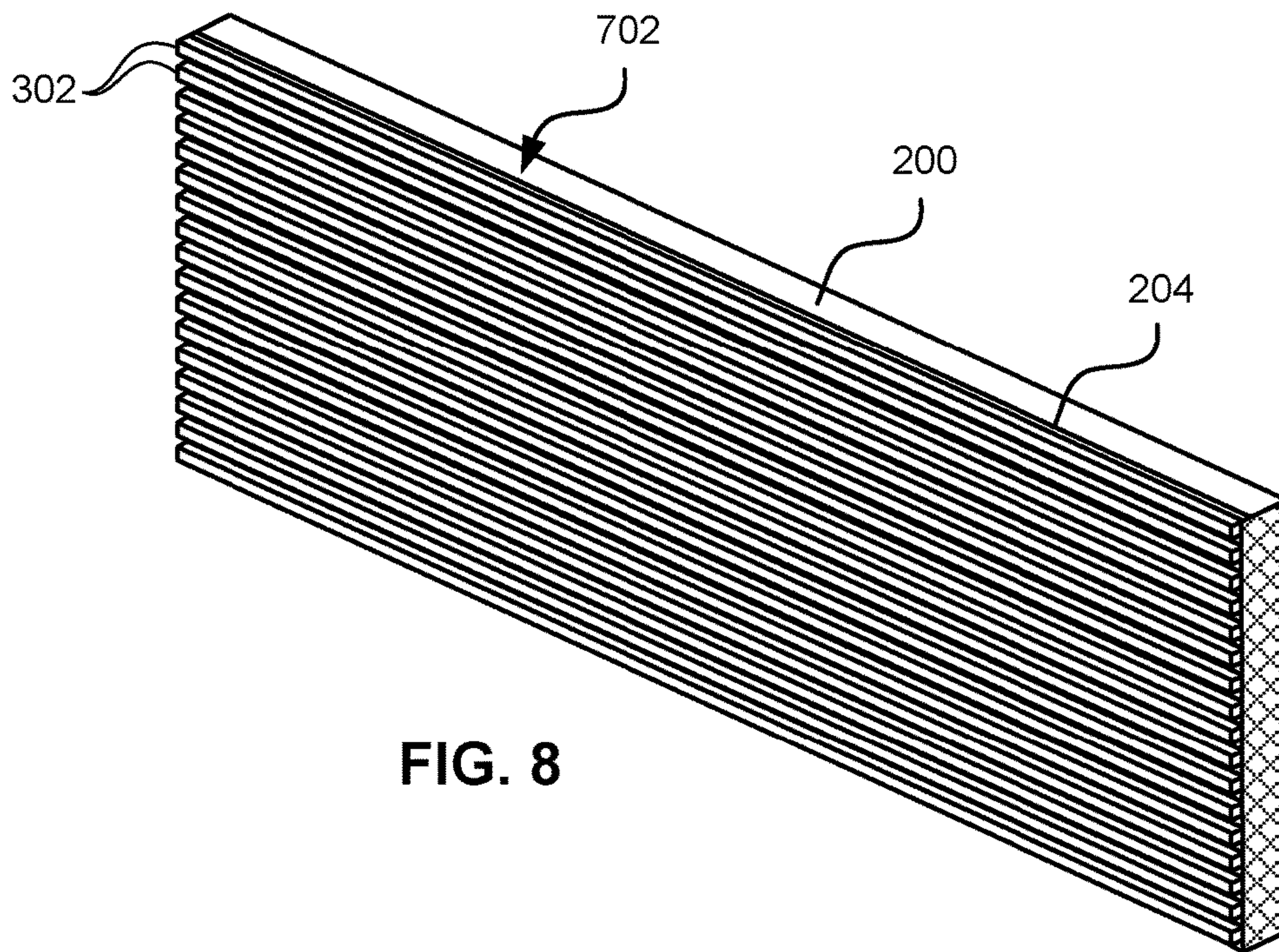

FIG. 8

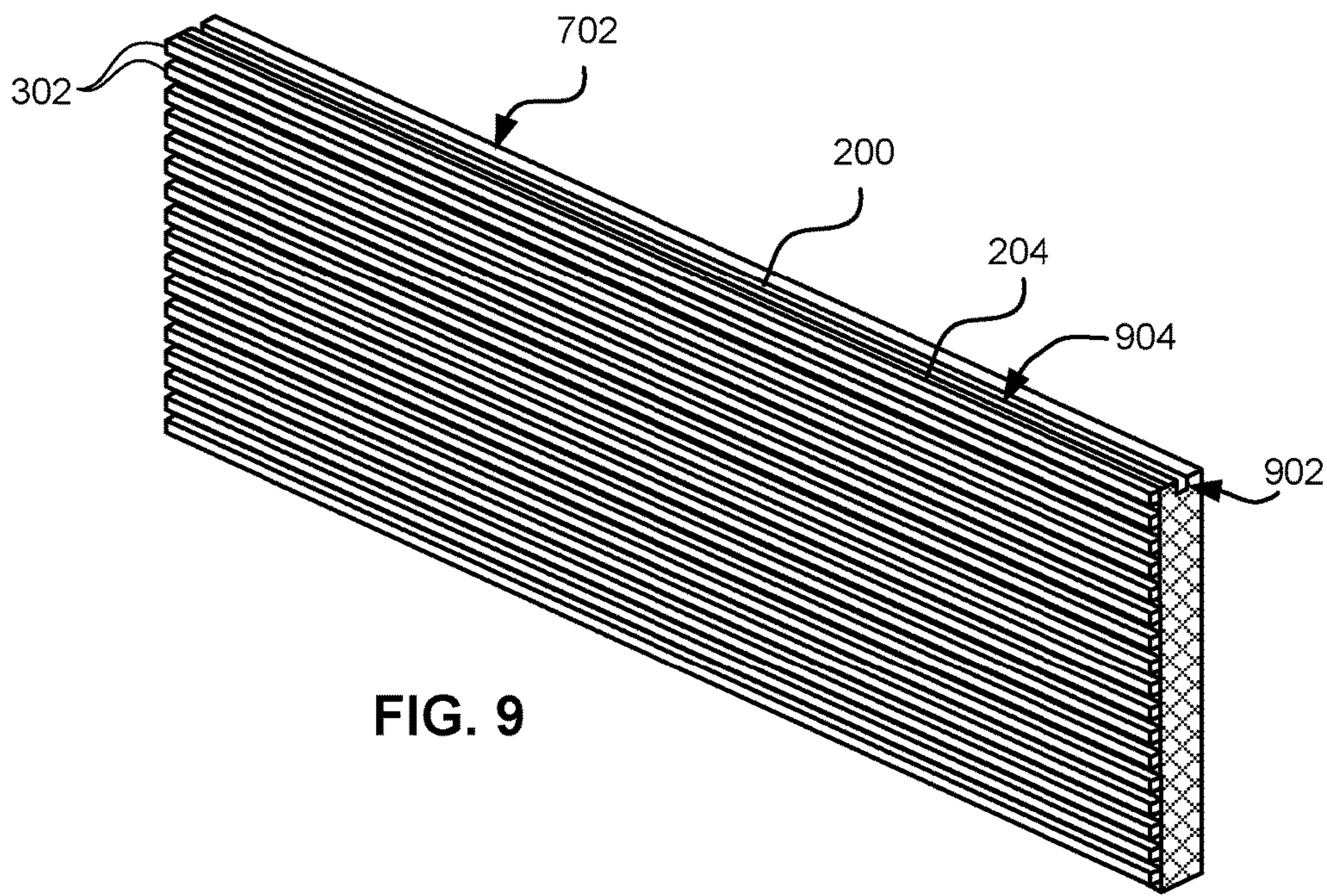

FIG. 9

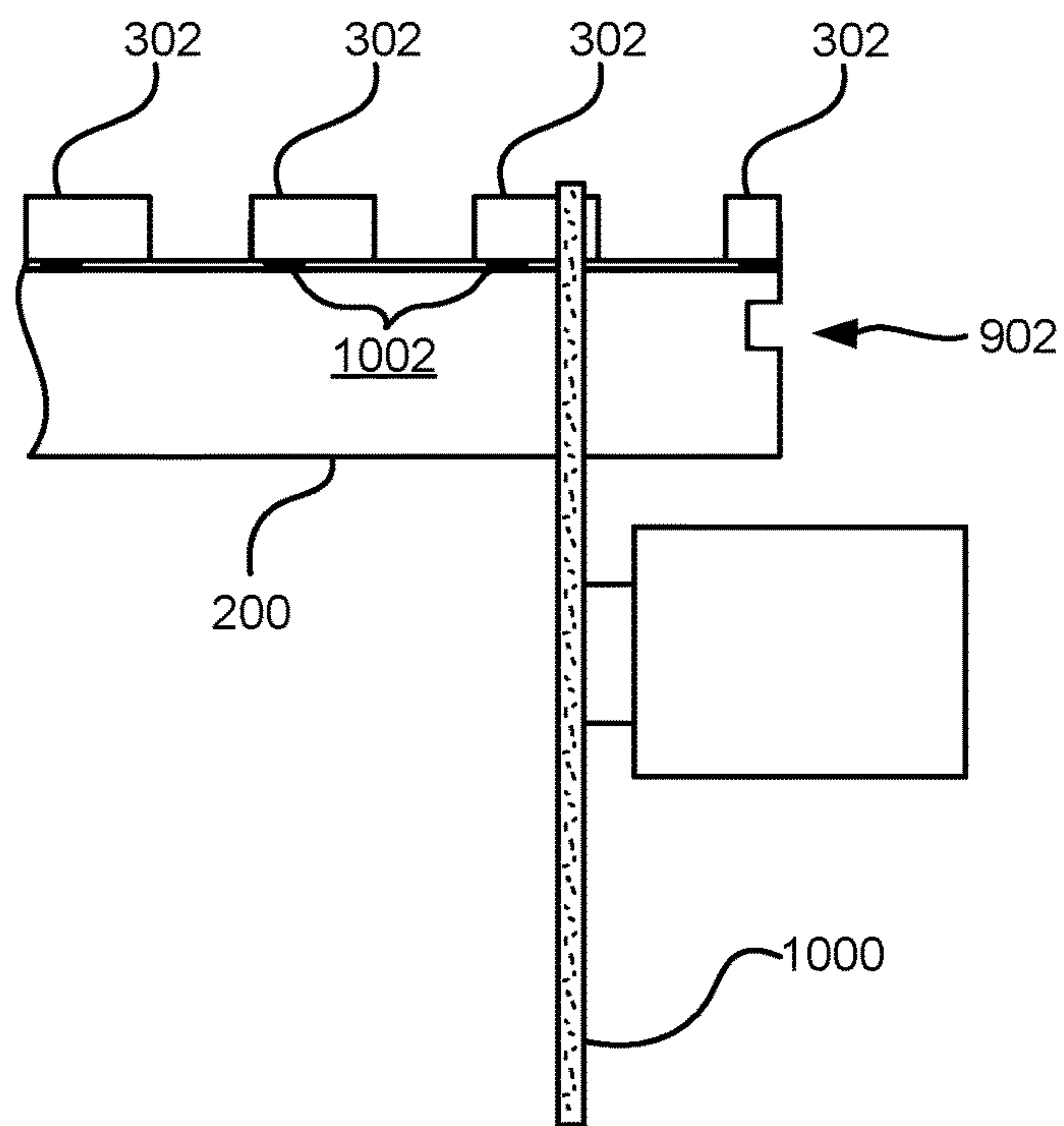

FIG. 10

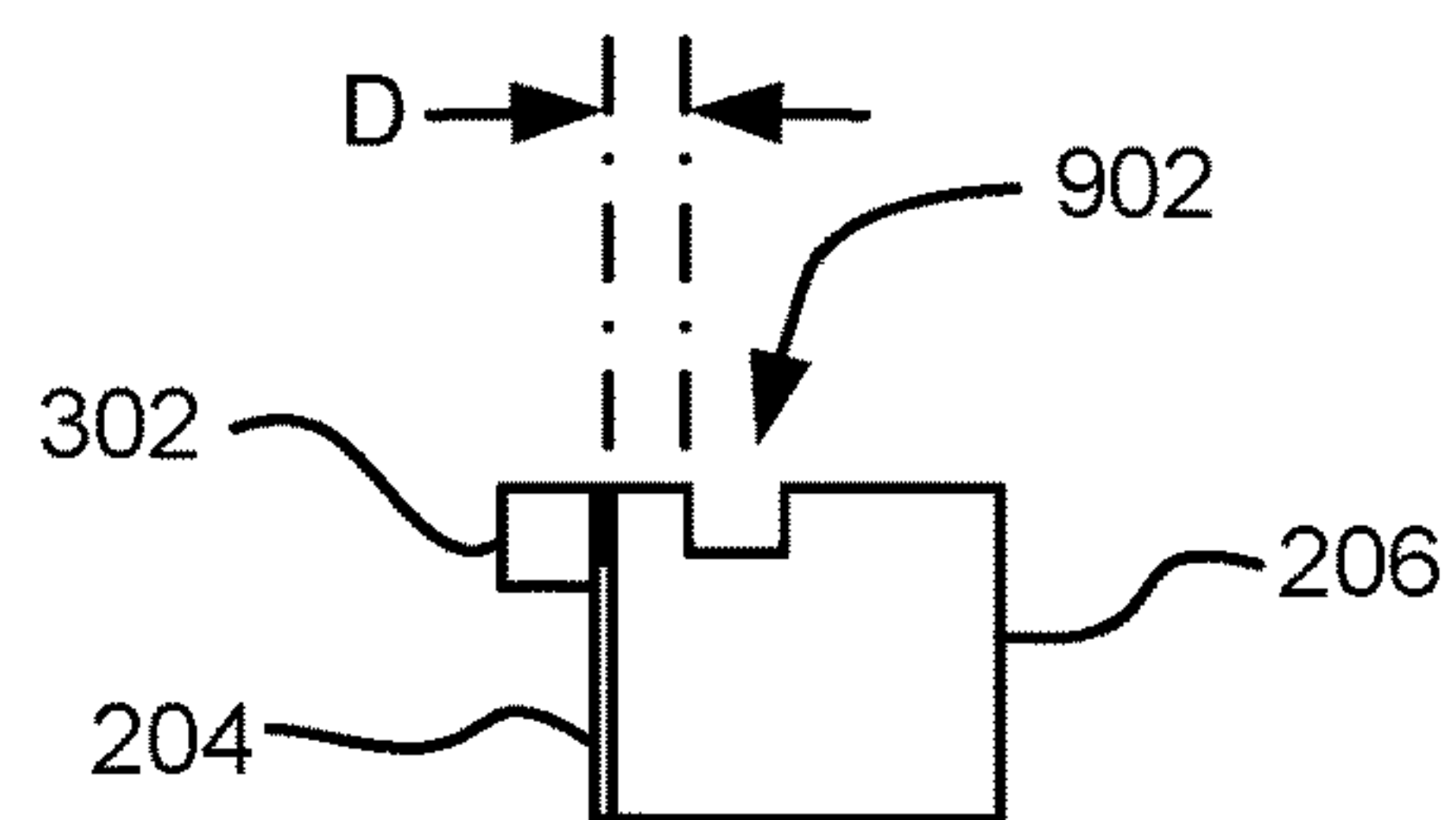

FIG. 11

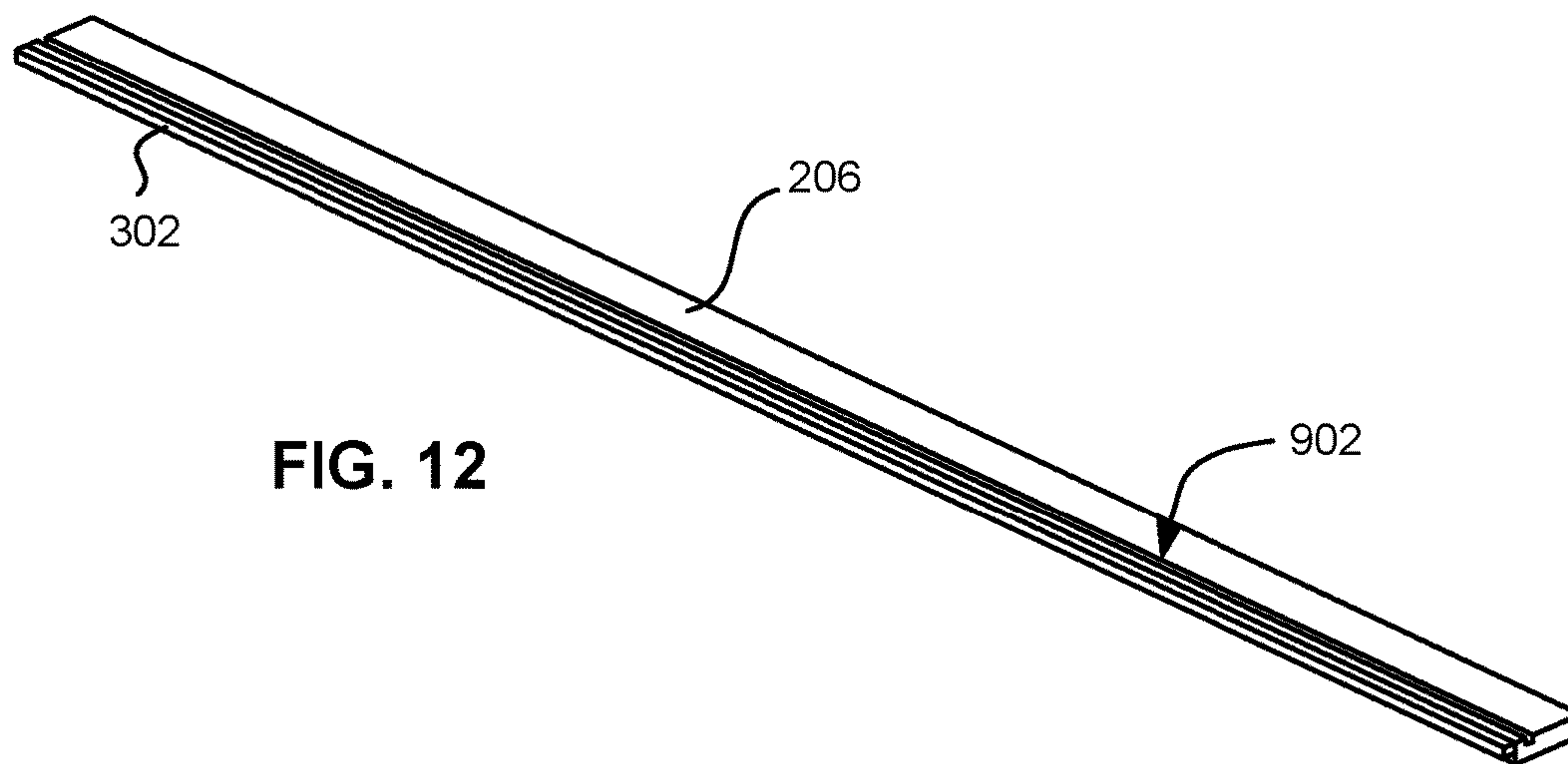

FIG. 12

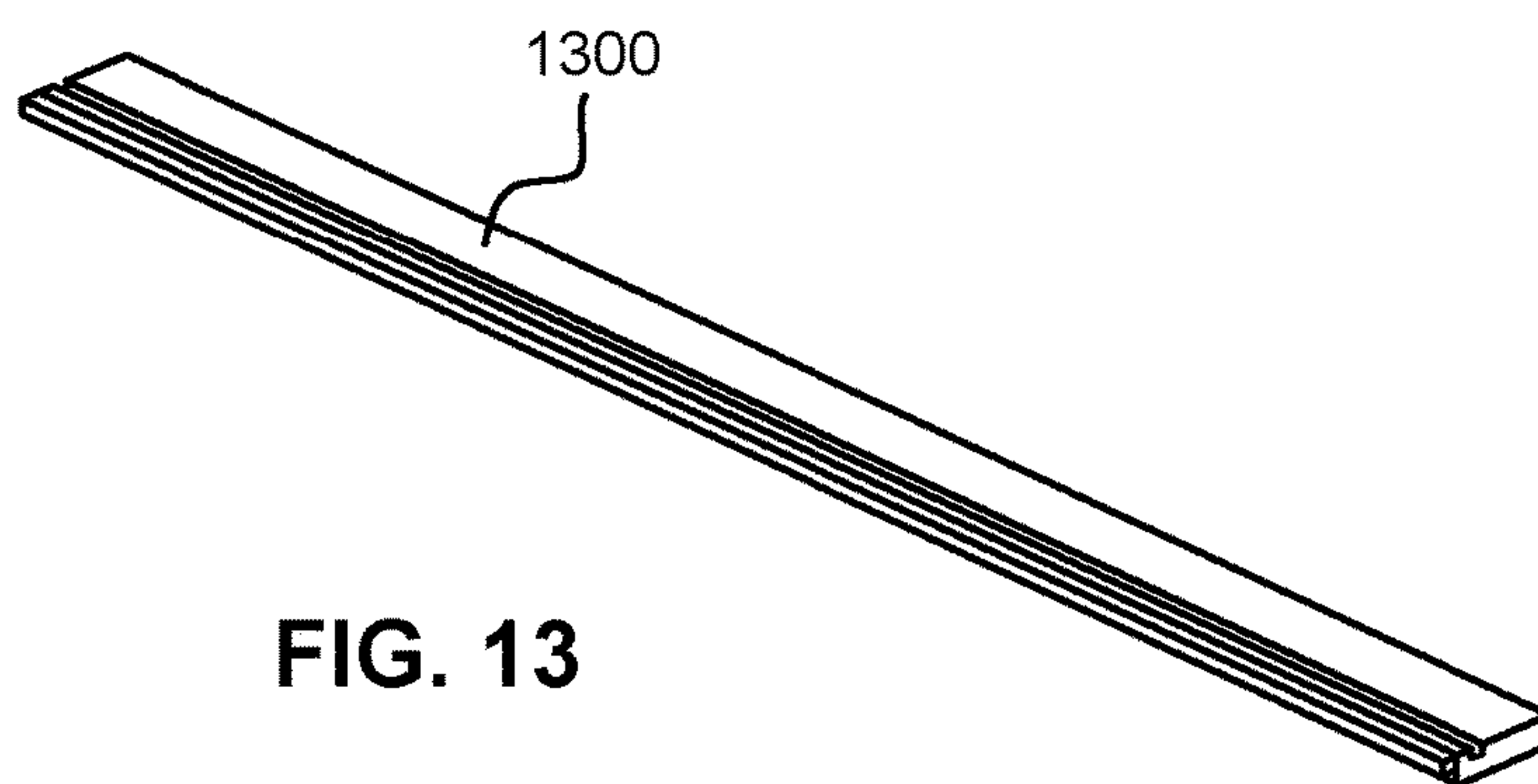

FIG. 13

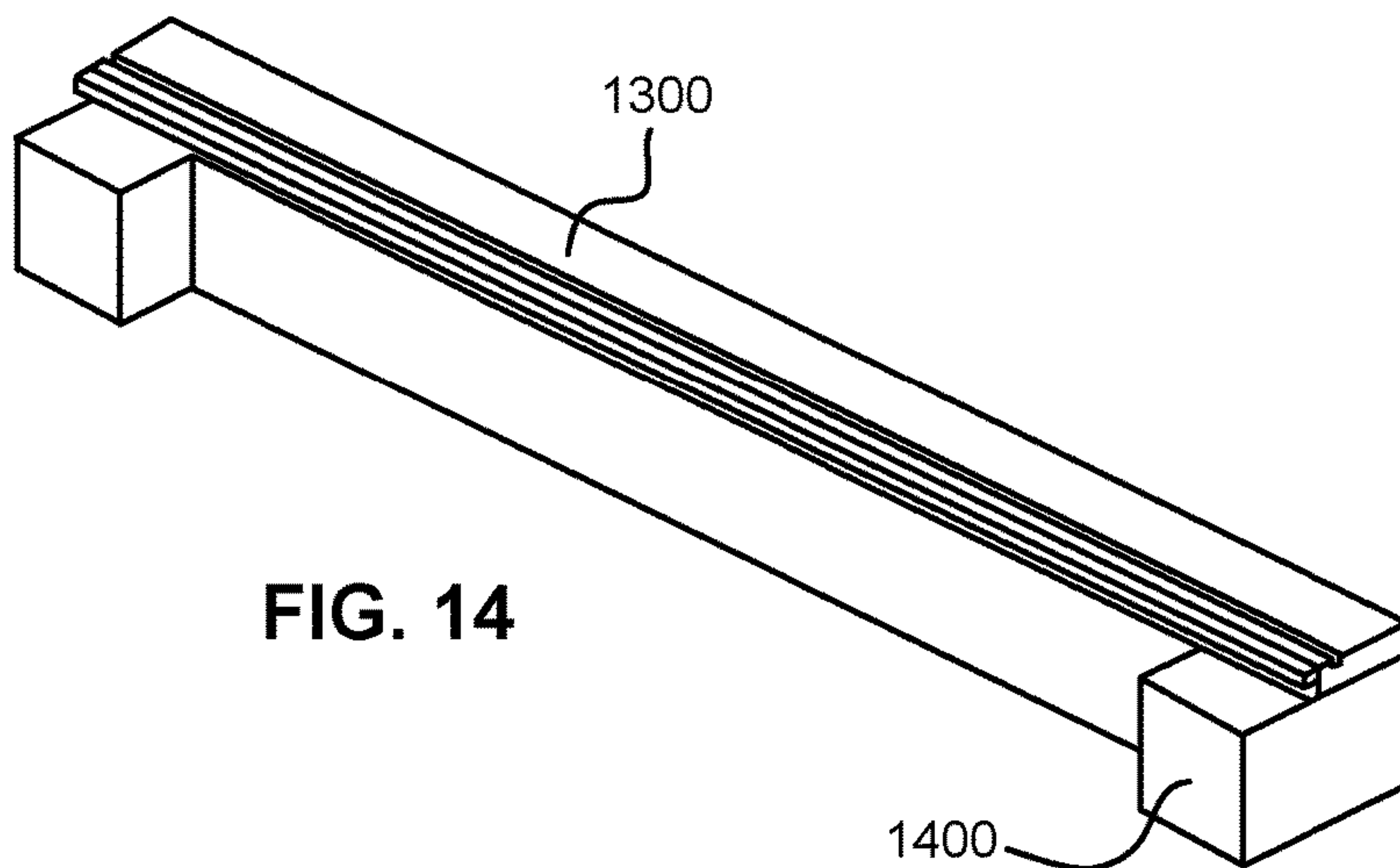

FIG. 14

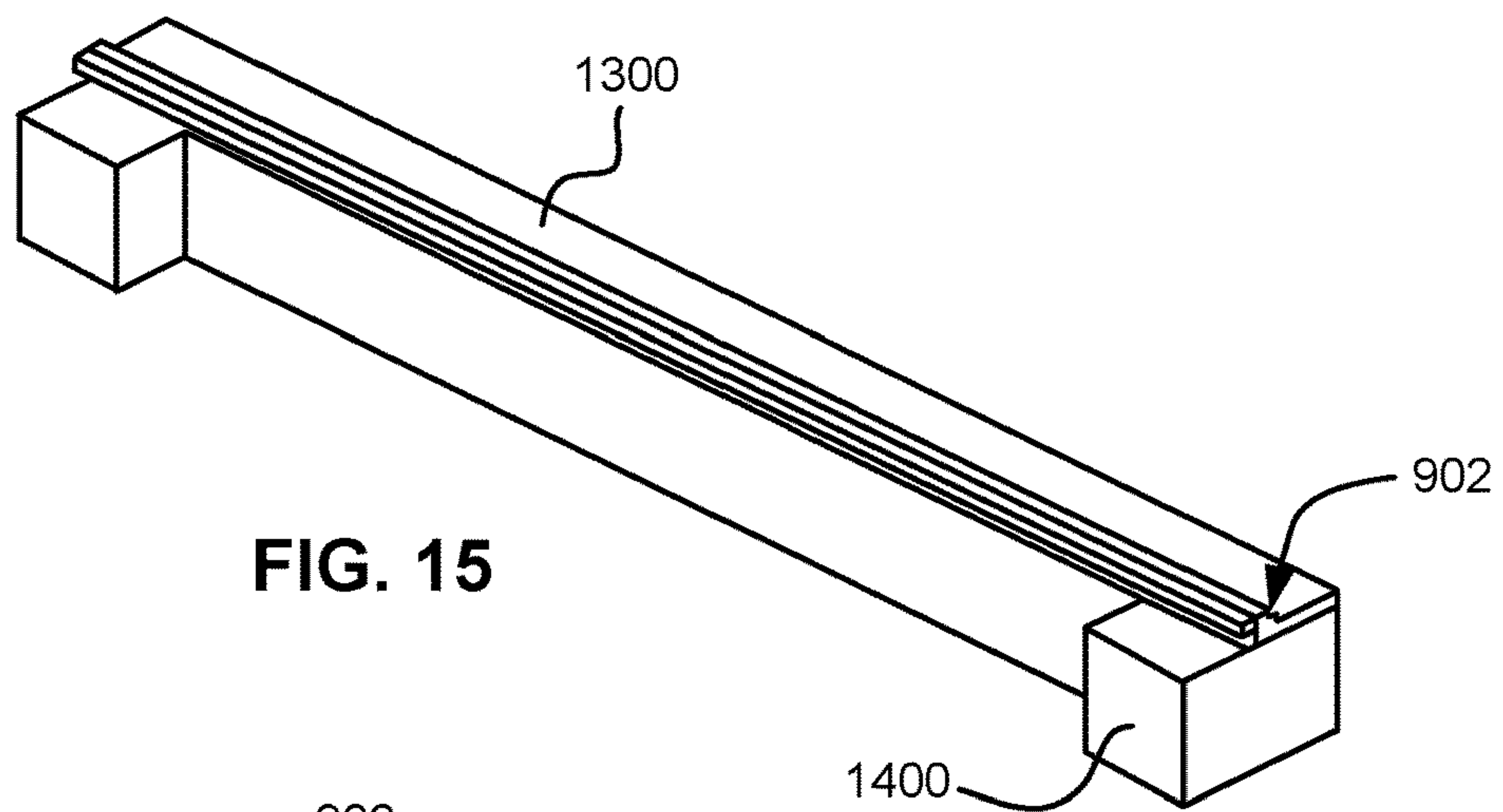

FIG. 15

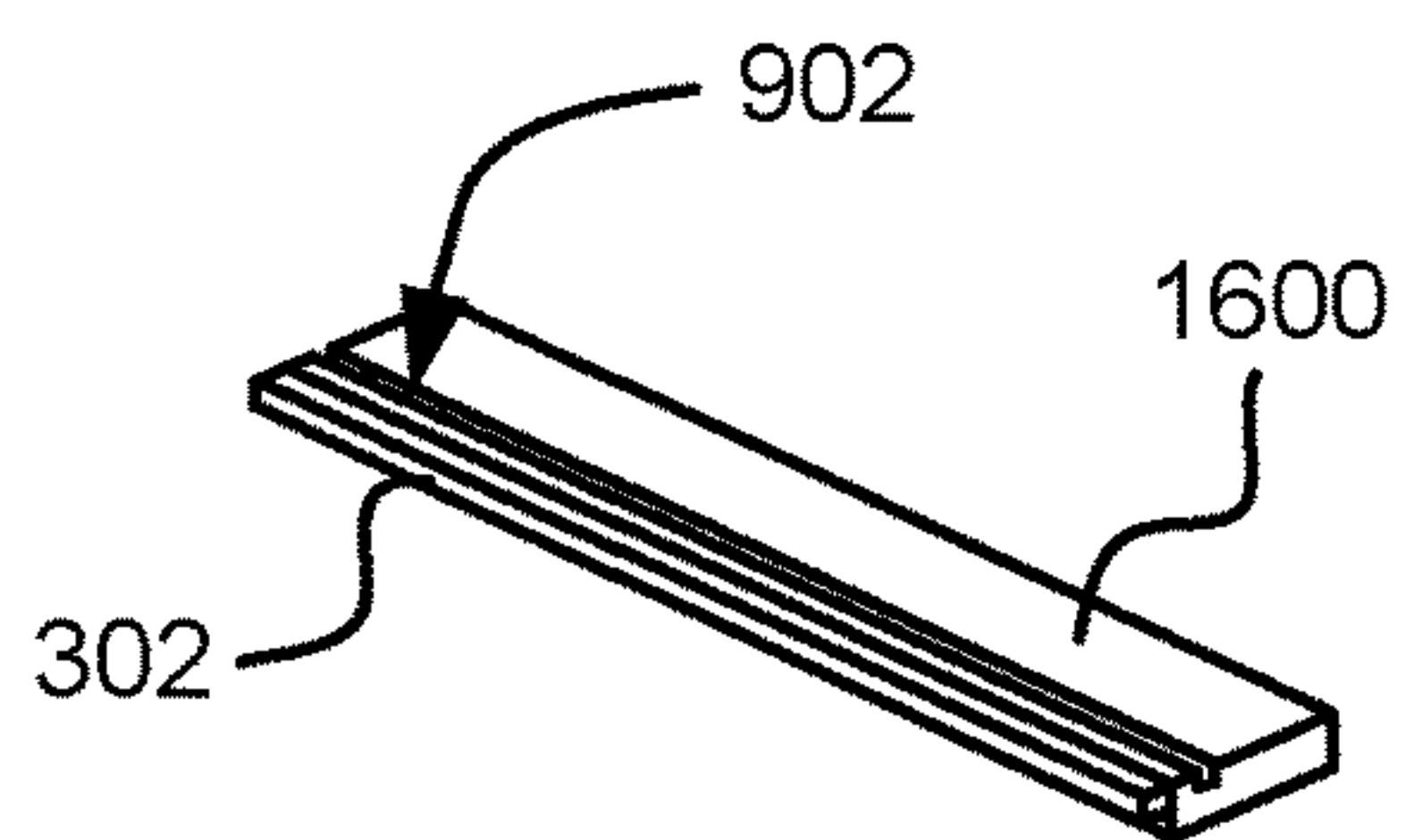

FIG. 16

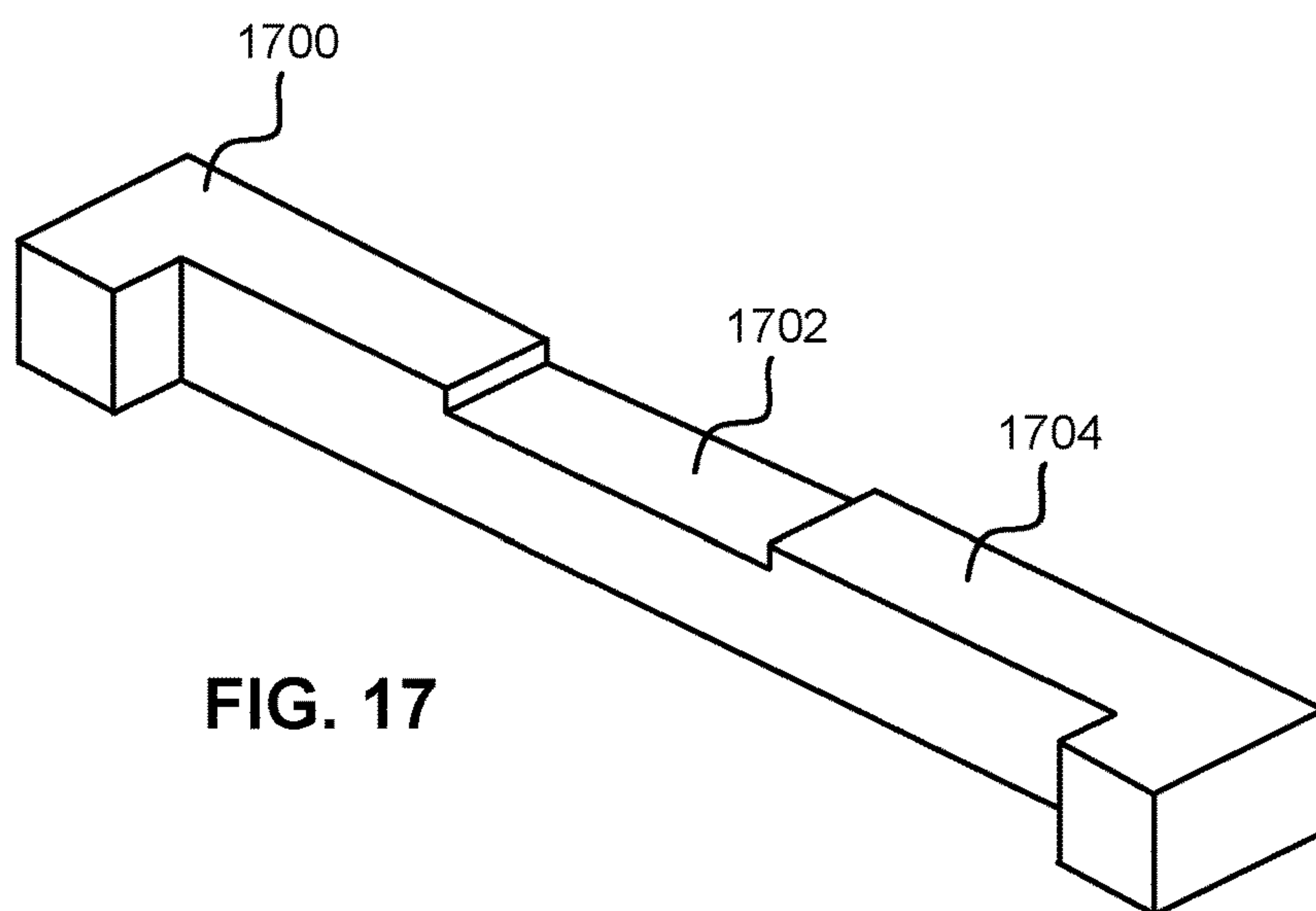

FIG. 17

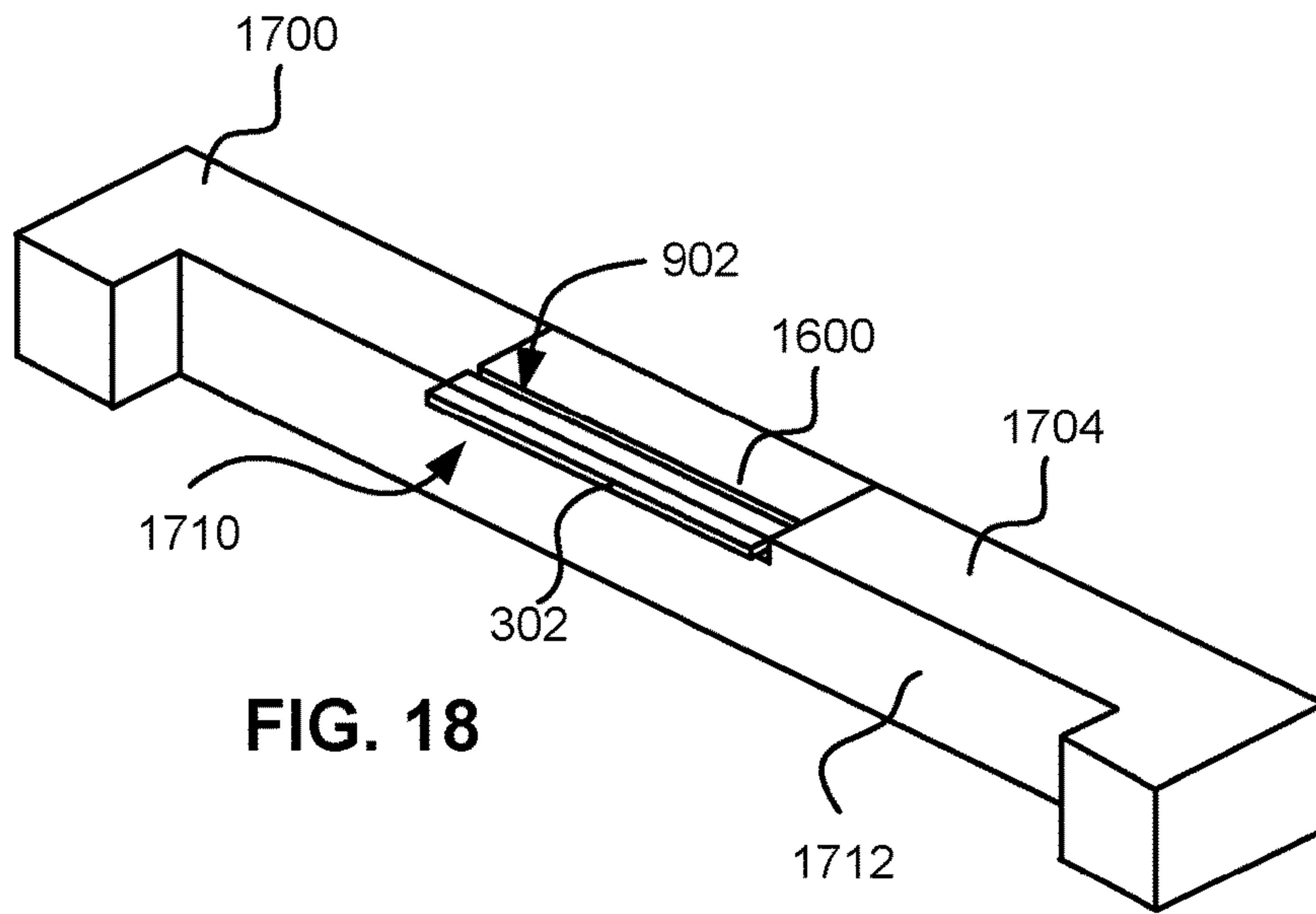

FIG. 18

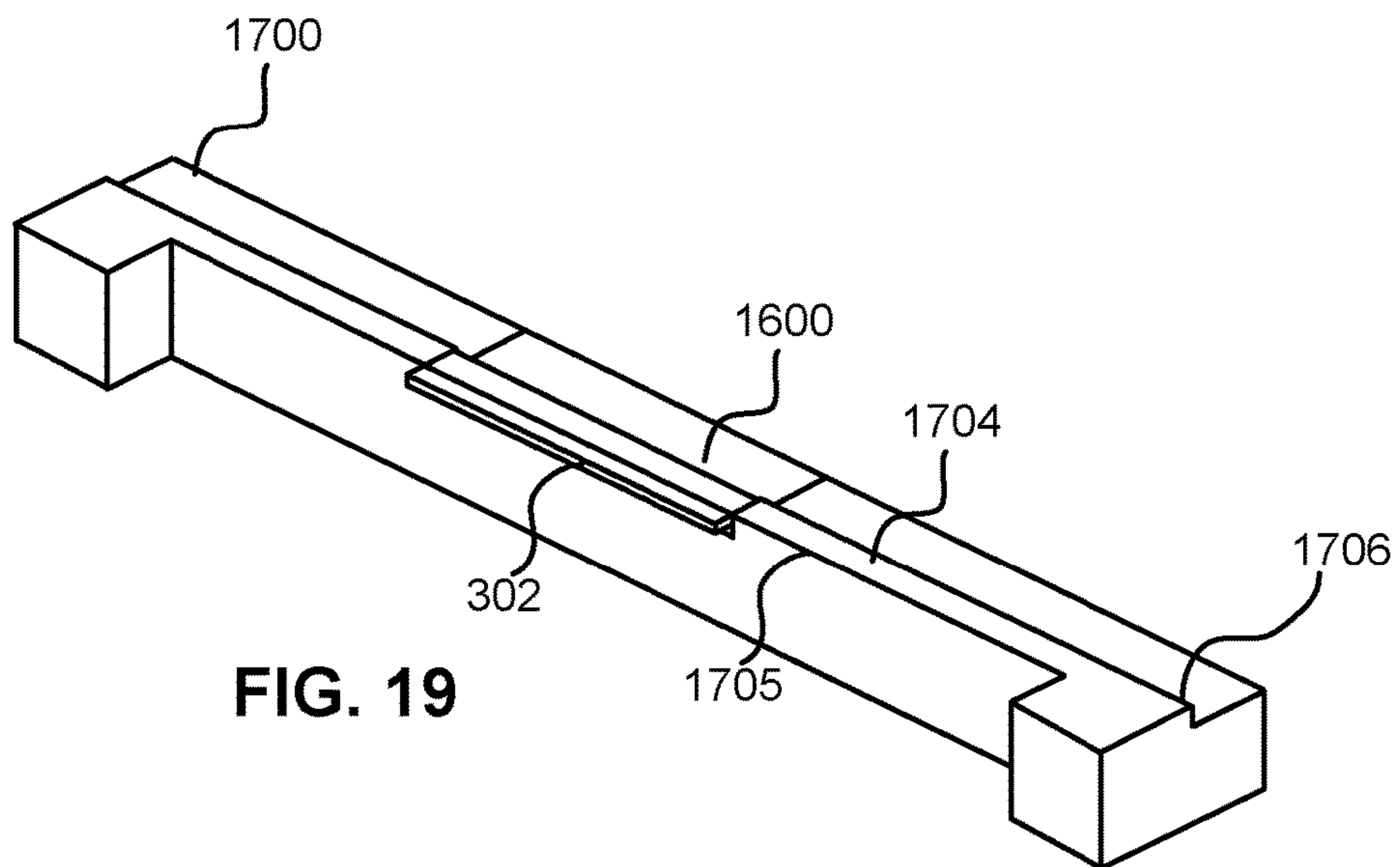
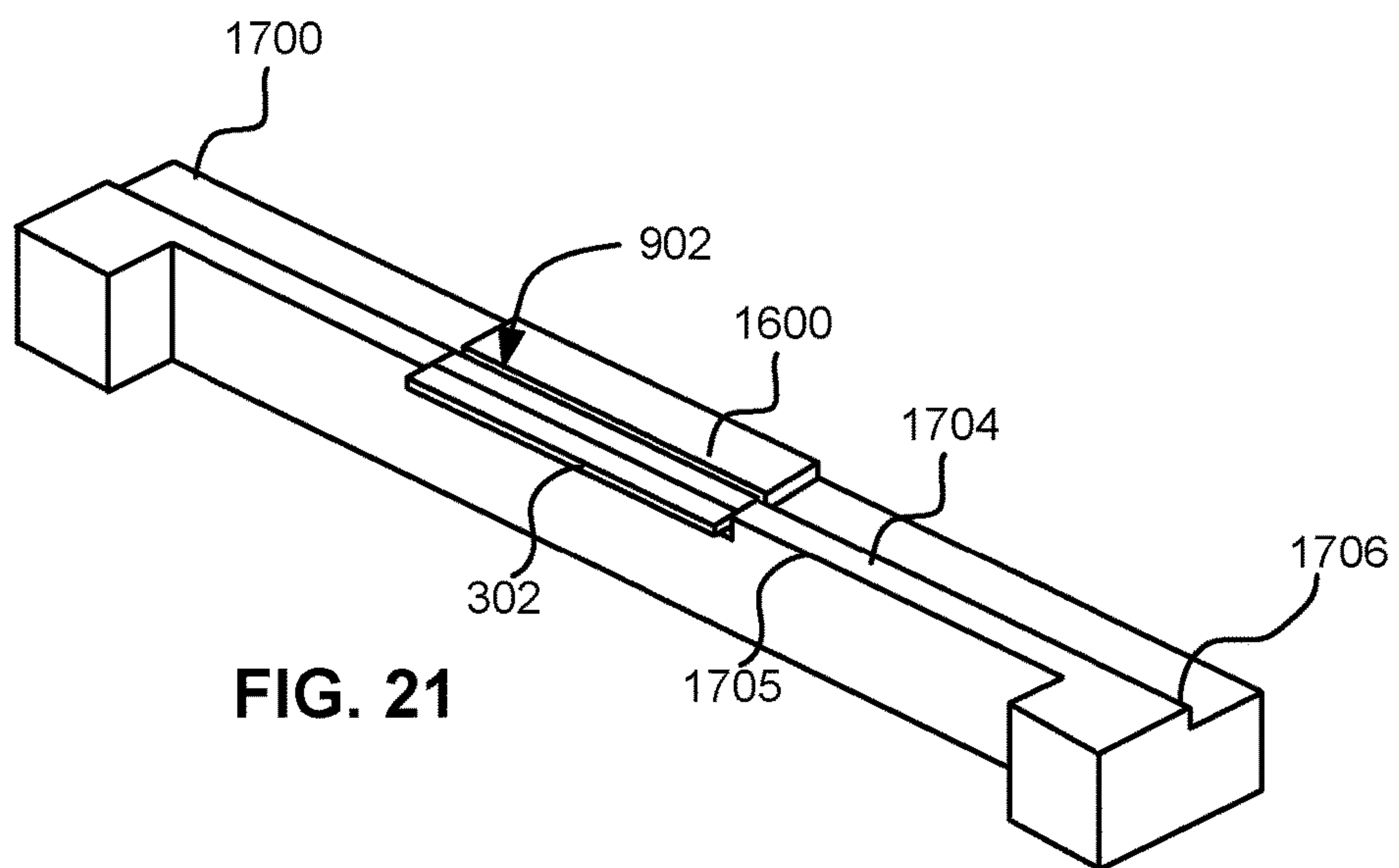
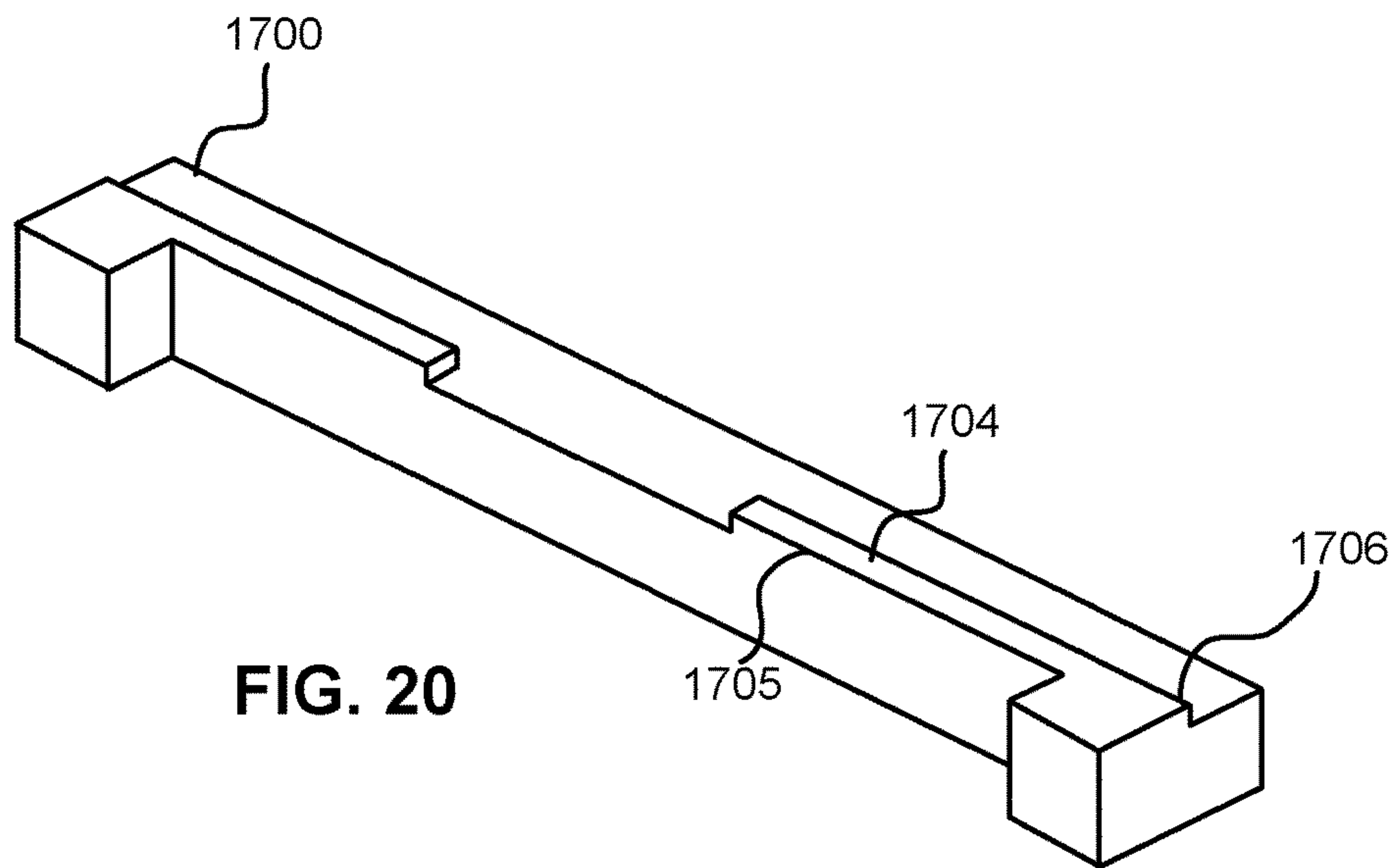
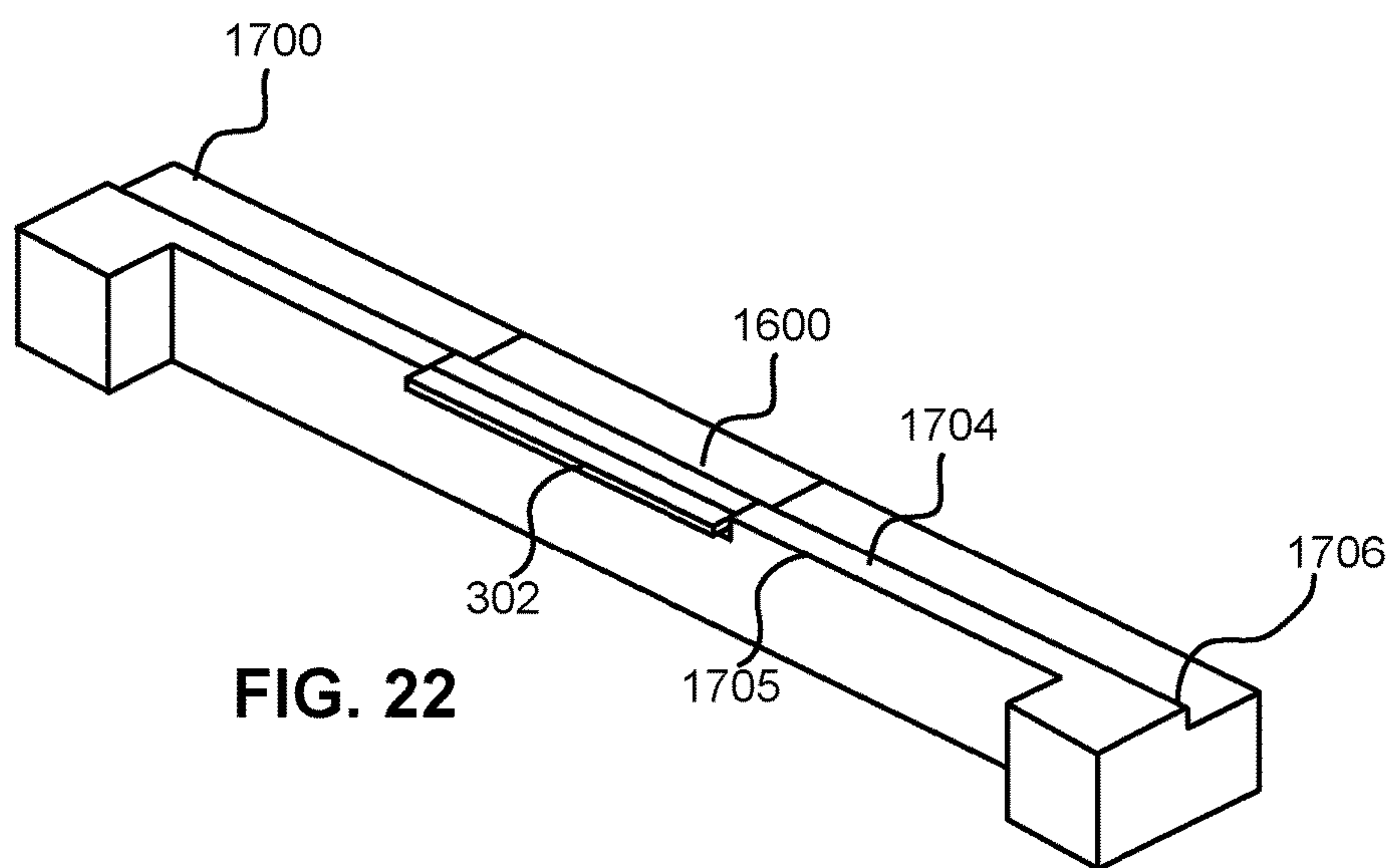

FIG. 19





**TAPE HEAD HAVING A PORTION OF A
BEARING SURFACE SLOT THAT DEFINES
A SKIVING EDGE**

BACKGROUND

The present invention relates to fabrication of magnetic heads, and more particularly, this invention relates to defining a tape bearing surface on a magnetic tape head.

Many modern electronic components are created by thin film wafer processing. One category of component created by thin film processing is the tape head. Another category is the disk head.

Most tape heads are currently built on wafers using thin film processes, similar to the wafers used for fabricating disk heads. However, the operating efficiency of disk heads and tape heads are inherently different. Disk recording/reading is very efficient, as the disk media is extremely flat and smooth, has a very thin magnetic layer, is in a sealed environment, and the heads are constructed to function with a particular media. Writing and reading tapes must address very different challenges. For example, the head should work with different tape brands, which can have different physical and magnetic properties. Furthermore, most tape is composed of magnetic particles, which are coated onto the tape surface. The resulting media can have variations in coating thickness and particle dispersion. This, coupled with spacing loss variations due to embedded wear particles and debris, requires that magnetic bits in tape be much larger than bits in disk media for achieving an acceptable signal-to-noise ratio.

Disk drive heads are designed to fly over smooth disk surfaces in a controlled manner at speeds exceeding 30 to 40 meters per second. By contrast, tape stacking and other requirements limit tape drive operating speeds to approximately 5 to 10 meters per second. Thus, to achieve data rates commensurate with disk drives, high performance linear tape drives typically employ heads having multiple transducers that operate simultaneously. For example, two transducers provide twice the data rate of one transducer, and modern heads have 32 transducers for each direction.

An important and continuing goal in the data storage industry is that of increasing the density of data stored on a medium. For tape storage systems, that goal has led to increasing the track and linear bit density on recording tape, and decreasing the thickness of the magnetic tape medium. However, the development of small footprint, higher performance tape drive systems has created various problems in the design of a tape head assembly for use in such systems.

For example, tolerances decrease as feature size decreases. Moreover, smaller components tend to be more fragile than their larger predecessors.

SUMMARY

An apparatus according to one embodiment includes a substrate, and a thin film layer on the substrate having transducers therein. A portion of a bearing surface slot extends along the substrate, the portion of the bearing surface slot defining a skiving edge. A length of a tape bearing surface between the substrate and the skiving edge is in a range of about 7 to about 30 microns.

A method according to one embodiment includes forming a bearing surface slot in an end of a section of a thin film wafer at a location that defines a tape bearing surface extending between the bearing surface slot and portions of transducers exposed on the end. The section has a plurality

of rows of transducers formed on a substrate. A row is sliced from the section, the row having the end and bearing surface slot.

A method according to another embodiment includes coupling closures to a section of a thin film wafer having a plurality of rows of transducers formed on a substrate, the closures being coupled to the section on an opposite side of the transducers as the substrate. A bearing surface slot is formed in an end of the section. A tape bearing surface is defined between the bearing surface slot and portions of the transducers exposed on the end. A row is sliced from the section, the row having the bearing surface slot. A portion of the end located on an opposite side of the bearing surface slot as the transducers is removed from the row or segment thereof.

Various embodiments may be implemented to fabricate a magnetic head usable with a magnetic data storage system such as a tape drive system, which may include the magnetic head, a drive mechanism for passing a magnetic medium (e.g., recording tape) over the magnetic head, and a controller electrically coupled to the magnetic head.

Other aspects and embodiments of the present invention will become apparent from the following detailed description, which, when taken in conjunction with the drawings, illustrate by way of example the principles of the invention.

BRIEF DESCRIPTION OF THE DRAWINGS

FIG. 1 is a side view of a tape head having closures.

FIG. 2 is a perspective view of a section of a thin film wafer according to one embodiment.

FIG. 3 is a perspective view of an array of closures.

FIG. 4 is a perspective view depicting coupling of the array of closures to the section of wafer.

FIG. 5 is a perspective view of the array of closures coupled to the section of wafer.

FIG. 6 is a perspective view of the closures coupled to the section of wafer upon removing a top portion of the array of closures.

FIG. 7 is a perspective view of the section of wafer of FIG. 6 in an inverted position.

FIG. 8 is a perspective view of the section of wafer of FIG. 7 upon polishing an end thereof.

FIG. 9 is a perspective view of the section of wafer of FIG. 8 upon formation of a bearing surface slot in an end thereof.

FIG. 10 is a side view depicting cutting of a row from a section of wafer.

FIG. 11 is a side view of a row cut from a wafer.

FIG. 12 is a perspective view of a row cut from a wafer after a back lap process to reduce a thickness thereof.

FIG. 13 is a perspective view of a chip cut from a row.

FIG. 14 is a perspective view of a U-beam with a chip coupled thereto, thereby forming a module.

FIG. 15 is a perspective view of a module upon forming of a skiving edge thereon.

FIG. 16 is a perspective view of a chip cut from a row.

FIG. 17 is a perspective view of a U-beam.

FIG. 18 is a perspective view of a U-beam with a chip coupled thereto, thereby forming a module.

FIG. 19 is a perspective view of a module upon forming of a skiving edge thereon.

FIG. 20 is a perspective view of a U-beam according to one embodiment.

FIG. 21 is a perspective view of a U-beam with a chip coupled thereto, thereby forming a module.

FIG. 22 is a perspective view of a module upon forming of a skiving edge thereon.

DETAILED DESCRIPTION

The following description is made for the purpose of illustrating the general principles of the present invention and is not meant to limit the inventive concepts claimed herein. Further, particular features described herein can be used in combination with other described features in each of the various possible combinations and permutations.

Unless otherwise specifically defined herein, all terms are to be given their broadest possible interpretation including meanings implied from the specification as well as meanings understood by those skilled in the art and/or as defined in dictionaries, treatises, etc.

It must also be noted that, as used in the specification and the appended claims, the singular forms “a,” “an” and “the” include plural referents unless otherwise specified.

The following description discloses several embodiments for producing tape heads having a precisely-positioned tape bearing surface edge.

In one general embodiment, a method includes lapping an end of a section of a thin film wafer for polishing the end of the section, the section having a plurality of rows of transducers formed on a substrate. A bearing surface slot is formed in the polished end at a location that defines a tape bearing surface extending between the bearing surface slot and portions of the transducers exposed on the polished end. A row is sliced from the section, the row having the polished end and bearing surface slot.

In one general embodiment, a method includes coupling closures to a section of a thin film wafer having a plurality of rows of transducers formed on a substrate, the closures being coupled to the section on an opposite side of the transducers as the substrate. Lapping is performed on an end of the section for polishing the end of the section and the closure. Optical detection of a reflective feature on the polished end is used to determine a location for a bearing surface slot. The bearing surface slot is formed in the polished end at the determined location. A tape bearing surface is defined between the bearing surface slot and portions of the transducers exposed on the polished end. A row is sliced from the section, the row having the polished end and bearing surface slot. A portion of the polished end located on an opposite side of the bearing surface slot as the transducers is removed from the row or segment thereof.

In yet another general embodiment, an apparatus includes a substrate, and a thin film layer on the substrate having transducers therein. A portion of a bearing surface slot extends along the substrate, the portion of the bearing surface slot defining a skiving edge. A length of a tape bearing surface between the substrate and the skiving edge is in a range of about 7 to about 30 microns.

One category of component created by thin film processing and post-wafer machining is the tape head. FIG. 1 depicts one such tape head 100. The head 100 includes a pair of head portions 102, each having a closure 104 that engages the tape 106 as it passes over the tape bearing surface of the head 100. The tape bearing surfaces may angle upwardly (towards the tape) so the tape wraps both substrate and closure edges.

According to the preferred method for forming the head, a wafer containing multiple “chips” each having read and/or write circuitry is formed by traditional thin film processing. The thin film wafer is cut into rectangular sections. FIG. 2 illustrates a section 200 of a thin film wafer according to one

embodiment. As shown, the section 200 includes a plurality of rows 202 of circuitry formed in a layer 204 of thin films formed on a substrate 206. The section 200 will eventually be sliced and cut to form a head or chip. The circuitry may include, for example, read transducers, write transducers, servo transducers, electronic lapping guides, etc. Each row 202 can contain multiple head images. Thus, while each row contains two head images in this figure, rows built according to various embodiments may have more or less than two head images.

FIG. 3 shows an array 300 of closures 302 that will be bonded to a section 200 of the wafer. The closures 302 may be of conventional construction. As shown, the closures 302 in this example extend from a top portion 304.

FIG. 4 illustrates how the array 300 is bonded to a section 200. A conventional adhesive may be used to bond the array 300 to the section 200.

FIG. 5 depicts the array 300 of closures 302 bonded to the section 200 of wafer. The top portion 304 of the array 300 of closures 302 may be removed prior to slicing the section 200 into rows 202. Portions of the closures 302 themselves may be removed as well to define the length of the tape bearing surface of each closure 302. Grinding, lapping, and/or other subtractive process may be used.

FIG. 6 shows the closures 302 and section 200 with the top portion 304 of the array of closures 302 removed. The portions of the closure 302 remaining after processing support the tape as the tape passes over the head to protect the delicate electronics in the head from wear.

FIG. 7 shows the section 200 of FIG. 6 inverted from the orientation shown in FIG. 6. The surface of the end 702 is rough from the processing step in which the section is cut from the wafer, e.g., where a cutting blade is used to cut the section 200 from the wafer. All surfaces of peripheral ends of the section 200 and closures 302 typically have a similar roughness from the cutting step. In FIG. 7, a texture has been added to the drawing to exemplify the roughness of the surfaces of the section 200. This roughness upsets optical recognition of features on the end 702, such as the location of the circuitry in the gap between the substrate upon which the circuitry is formed and the closure 302 and so reduces the precision. Therefore, optical positioning techniques are not available for locating positions to make cuts. This limited ability to precisely locate features on the end 702 was not an issue for conventional head processing techniques, because a long tape bearing surface was desired. However, where a shorter tape bearing surface is desired and/or a skiving edge is to have a very specific placement relative to the thin film layer, more precision is needed.

Accordingly, the end 702 of the section 200 is lapped for polishing the end 702 and the closure 302. Conventional lapping techniques may be used. FIG. 8 depicts the section 200 with a polished end 702. Once lapped, the polished surface of the end 702 is amenable to use of optical detection techniques to identify features thereof. For example, features in the thin film layer 204 are observable once the polishing is performed.

Optical detection of a reflective feature on the polished end may be used to determine a precise location for a bearing surface slot. Such reflective feature may be any optically discernable portion of the polished end. For example, the reflective portion may be a portion of the circuitry such as a shield, an electronic lapping guide, etc. that are now clearly discernable on the polished surface. In another approach, the reflective feature may be a fiducial built into the thin film layer 204 at a predefined location. In yet another approach, the reflective feature may be a portion

having a different color or contrast than an adjacent portion, e.g., the first layer or first few layers of the thin film layer on the substrate. Conventional optical detection techniques may be adapted for the purposes described herein, as would be appreciated by one skilled in the art upon reading the present disclosure. Machine vision techniques may be used. Preferably, the resolution of the optical detector is in the sub-micron level.

Using information derived from the optical detection, a bearing surface slot is formed at a precise location in the polished end. FIG. 9 illustrates the section 200 having a bearing surface slot 902 formed in the polished end 702 thereof. The bearing surface slot 902 defines a tape bearing surface 904 between the bearing surface slot and the thin film layer 204. Where a portion of the circuitry exposed on the polished end is used as the optical landmark for the bearing surface slot positioning, the length of the tape bearing surface between the bearing surface slot and that portion of the circuitry may be very accurately defined.

Any conventional mechanism for forming the bearing surface slot may be used. For example, a conventional air bearing spindle saw with machine vision may be used to create the bearing surface slot at the proper location.

The depth of the bearing surface slot 902 is preferably less than about 3 times a width thereof in a tape travel direction. This helps maintain the integrity of the resulting module. The width of the bearing surface slot is not as important, and generally depends on the width of the blade use to cut the bearing surface slot. For example, the depth of the bearing surface slot may be about 10 to about 20 microns deep, but could be higher or lower depending on the embodiment.

Referring to FIG. 10, a row is then sliced from the section 200. Transducers 1002 are also shown adjacent each closure 302. Conventional cutting techniques may be used to slice the row from the section 200. For example, a blade 1000 of conventional construction may be used to cut through the section 200.

FIG. 11 depicts the row cut from the section 200. Various process steps may be performed on the row. For example, a back lapping step may be performed on the substrate 206 to reduce its thickness, and/or to create a smooth bottom end for subsequent processing. FIG. 12 depicts the row after back lapping.

If the row includes multiple head images, the row may be cut into chips. Preferably, the rows are cut into individual thin film elements, or chips 1300, using traditional methods. See FIG. 13, which illustrates one chip 1300.

Each chip 1300 may be coupled to a beam such as a U-beam 1400, as shown in FIG. 14. Various processes may be performed before or after coupling to the beam.

Additional processes may be performed, before or after the chip 1300 is coupled to a beam. For example, the row or chip may be lapped again, using conventional techniques such as KISS lapping on a charged plate, to remove a burr from the polished end, such as a bearing surface slot burr formed during formation of the bearing surface slot. Milling may be performed, e.g., for preparing the polished surface for application of a protective overcoat thereto. An overcoat may be applied to the polished end.

Before or after the cutting, the portion of the polished end located on an opposite side of the bearing surface slot as the circuitry is removed using a conventional technique such as grinding, e.g., a taperless grind technique. FIG. 15 shows the chip 1300 upon removal of the material. Preferably, the removal extends along the bearing surface slot, thereby

allowing the remaining portion of the bearing surface slot to define the skiving edge of the tape bearing surface of the chip.

Referring to FIGS. 9 and 11, the bearing surface slot 902 may be located a distance D of less than about 30 microns, and preferably between about 10 and about 20 microns, from the thin film layer 204. This distance D, in combination with a wrap angle of a tape relative to the skiving edge of the bearing surface slot, is preferably short enough to induce tape tenting above the thin film layer 204 when a tape passes above the thin film layer 204. Accordingly, D is preferably less than about 50 microns. In some embodiments, D may be in a range of about 7 microns to about 30 microns. Such tape tenting may prevent asperities and other defects on the tape from engaging the thin film layer 204 and causing damage thereto such as smearing of conductive material across the sensor, thereby creating a short.

Two or more beams 1400 may eventually be coupled together to form a head.

In use, the thin film elements created by the processes described herein can be used in magnetic recording heads for any type of magnetic media, including but not limited to disk media, magnetic tape, etc.

As shown in FIG. 15, the chip 1300 is at least as wide as a tape for which the tape bearing surface is designed. However, other embodiments are contemplated. For example, shorter chip may be fabricated, as described immediately below.

According to various embodiments, the processes described herein may be used to form a partial span flat or contoured head "chip," the chip being embeddable in a flat or contoured beam, such that the chip closure extends beyond the beam edges. For example, the rows may be cut into individual partial span heads, or chips 1600, using traditional methods. See FIG. 16, which illustrates a partial span flat profile chip 1600 according to a preferred embodiment. If the chip is to be used in a Linear Tape Open (LTO) head, the preferred length of the chip in a direction perpendicular to the direction of tape travel thereover is preferably less than about 7 to 8 mm, though larger or smaller sizes may be created as well.

Similar processes as those described above with reference to FIGS. 2-13 may be used to form the chip 1600, with the exception of the length of chip cut from the section. Note also that chip 1600 includes the bearing surface slot 902.

FIG. 17 illustrates a flat profile beam (carrier) 1700 according to one embodiment. One skilled in the art will understand that many different shapes of the beam can be used. For instance, the beam may be block shaped, e.g., have a generally rectangular cross section when viewed from the tape bearing surface. The beam may also include rounded and/or tapered portions. For simplicity and ease of understanding, the following description will be described with reference to a U-shaped beam, or U-beam.

With continued reference to FIG. 17, the U-beam 1700 has a recess 1702 extending into a tape bearing surface 1704 thereof. The U-beam is preferably formed from a blank piece of wafer stock, which is inexpensive to fabricate, but is long enough to fully support the tape. If the U-beam is to be used in an LTO head, the preferred length of the U-beam in the same plane as, but in a direction perpendicular to, the direction of tape travel thereover is preferably less than about 50 mm, and ideally less than about 25 mm, but may be longer. Before the chip is affixed to the U-beam to form the module, the tape bearing surface on one of the U-beams may be lapped or polished to form a smooth tape bearing surface thereon.

As shown in FIG. 18, a chip 1600 is positioned in the recess of the U-beam such that the face 1710 of the substrate portion of the chip (which contains the device contact pads) is reasonably proximate to the adjacent face 1712 of the U-beam and coupled to the U-beam 1700 by any conventional technique, such as via an adhesive, such that the chip closure extends beyond the beam edges. This forms a module, which is later used to form a complete tape head. The geometry of the chip may be specifically adapted to minimize closure protrusion, and thereby minimize tape deflections effects.

The tape bearing surfaces (of the chip and U-beam) should be as parallel and coplanar as possible because the tape will run across them. However, the tape bearing surfaces do not need to be perfectly coplanar, as this design provides some tolerance for misalignment. Thus, the chip surface envelope may deviate from the tape bearing surface of the U-beam by several micrometers. This tolerance relief greatly reduces fabrication costs.

As shown in FIG. 19, the tape bearing surface of a U-beam 1700 can be processed (e.g., by grinding) to form a skiving edge 1706 thereon. The skiving edge 1706 is preferably formed as close to the remaining edge of the bearing surface slot as possible.

Two modules can be coupled together to form a head with spacing between the central portions of the beams, such as a head of the type shown in FIG. 1. Preferably skiving edges are formed on both modules to enable bi-directional reading and writing. In addition, the inside edges 1705 may be made sharp so that these will also skive air. Alternatively, the inside edges 1705 may be rounded if desired.

Preferably, the closures are angled upwardly into the tape bearing surface (i.e., as they approach each other, preferably at an angle between 0.1 to 2 degrees, with respect to the horizontal line between them. The angle of the closures may be used to create an air skiving effect for close head-tape spacing and/or to create a tenting effect.

Preferably, the wrap angle between the two modules creates the desired tenting over the read transducers.

All of the read and/or write elements in the head are preferably positioned in the chips. Note that each chip can have multiple read and write elements, such as interleaved read/write elements. Alternatively, one chip can have all write elements and the other chip can have all read elements. Other combinations are also possible. In this way, a read/write head can be formed.

FIGS. 20-22 illustrate an alternate embodiment having components similar to those of FIGS. 16-19, and accordingly have common numbering therewith. As shown in FIG. 20, the beam 1700 has a rear skiving edge 1706 already formed thereon. In FIG. 21, the chip 1600 is coupled to the beam 1700. FIG. 22 shows the module after a portion of the chip 1600 behind the bearing surface slot is removed.

The heads created by the processes described herein can be used in magnetic recording heads for any type of magnetic media, including but not limited to disk media, magnetic tape, etc.

While various embodiments have been described above, it should be understood that they have been presented by way of example only, and not limitation. For example, the structures and methodologies presented herein are generic in their application to all types of thin film devices. Thus, the breadth and scope of a preferred embodiment should not be limited by any of the above-described exemplary embodiments, but should be defined only in accordance with the following claims and their equivalents.

What is claimed is:

1. An apparatus, comprising:

a module, comprising:

a beam;

a substrate having a lower surface seated on an upper surface of the beam,

wherein all portions of the beam are positioned below a plane extending

along the lower surface of the substrate; and

a thin film layer on the substrate having transducers therein;

a portion of a bearing surface slot extending along the substrate,

the portion of the bearing surface slot defining a skiving edge,

the portion of the bearing surface slot having an upper surface recessed from, and oriented about parallel to,

a tape bearing surface extending along the substrate between the thin film layer and the skiving edge; and

a surface of the substrate recessed from, and oriented about parallel to, the upper surface of the portion of the bearing surface slot,

wherein the surface of the substrate recessed from, and oriented about parallel to, the upper surface of the portion of the bearing surface slot extends to a back edge of the substrate, wherein a plane extending along the back edge of the substrate defines an extent of the beam.

2. The apparatus as recited in claim 1, further comprising a closure coupled to the thin film layer on an opposite side thereof as the substrate; and a second module having a second closure facing the closure, the closure being positioned and angled relative to the second closure to create a tenting effect of a tape over the thin film layer as the tape moves in a direction from the second closure to the closure.

3. The apparatus as recited in claim 1, wherein a depth of the bearing surface slot is less than about 3 times a width thereof in a tape travel direction, wherein a length of the tape bearing surface defined between the thin film layer and the skiving edge is in a range of about 7 to about 30 microns.

4. The apparatus as recited in claim 3, wherein the length is between about 10 and about 20 microns.

5. The apparatus as recited in claim 1, wherein a width of the substrate in a direction perpendicular to a tape travel direction is at least as wide as a tape for which the tape bearing surface is designed.

6. An apparatus as recited in claim 1, further comprising: a drive mechanism for moving a magnetic medium over the transducers; and

a controller electrically coupled to the transducers.

7. The apparatus as recited in claim 1, comprising a closure coupled to an opposite side of the thin film layer as the substrate, wherein a tape bearing surface of the closure is coplanar with the tape bearing surface defined between the thin film layer and the skiving edge.

8. The apparatus as recited in claim 1, wherein the tape bearing surface is a polished portion of the substrate.

9. The apparatus as recited in claim 1, comprising a tape extending across the tape bearing surface; and a component selected from the group consisting of a closure and a second tape bearing surface, the component being spaced from the skiving edge and positioned to create a predefined wrap angle of the tape relative to the skiving edge that, in combination with a length of the tape bearing surface defined between the thin film layer and the skiving edge, induces tape tenting over the thin film layer as the tape moves in a direction from the component toward the skiving edge.

9

10. An apparatus, comprising:
 a substrate; and
 a thin film layer on the substrate having transducers
 therein; and
 a portion of a bearing surface slot extending along the
 substrate, the portion of the bearing surface slot defin- 5
 ing a skiving edge,
 wherein a tape bearing surface of the substrate is defined
 between an edge of the substrate on which the thin film
 layer is formed and the skiving edge, a length of the 10
 tape bearing surface of the substrate being in a range of
 about 7 to about 30 microns,
 wherein the portion of the bearing surface slot has an
 upper surface recessed from, and oriented about paral- 15
 lel to, the tape bearing surface of the substrate between
 the thin film layer and the skiving edge; and
 wherein the substrate has a surface recessed from, and
 oriented about parallel to, the upper surface of the
 portion of the bearing surface slot, 20
 wherein the surface of the substrate recessed from, and
 oriented about parallel to, the upper surface of the
 portion of the bearing surface slot extends to a back
 edge of the substrate, wherein a plane extending along

10

the back edge of the substrate defines an extent of a
 beam on which the substrate is seated.

11. The apparatus as recited in claim 10, further compris-
 ing a closure coupled to the thin film layer on an opposite
 side thereof as the substrate, the substrate being seated on
 the beam of a first module; and a second closure on a second
 module, the closure being positioned and angled relative to
 the second closure to create a tenting effect of a tape over the
 thin film layer as the tape moves in a direction from the
 second closure to the closure.

12. The apparatus as recited in claim 11, comprising the
 tape extending across the tape bearing surface, the tape
 exhibiting tenting over the thin film layer.

13. The apparatus as recited in claim 10, comprising a
 component selected from the group consisting of a closure
 and a second tape bearing surface, the component being
 spaced from the skiving edge and positioned to create a
 predefined wrap angle of a tape relative to the skiving edge
 that, in combination with a length of the tape bearing surface
 defined between the thin film layer and the skiving edge, 20
 induces tape tenting over the thin film layer as the tape
 moves in a direction from the component toward the skiving
 edge.

* * * * *