



US010257622B2

(12) **United States Patent**
Higgins et al.

(10) **Patent No.:** **US 10,257,622 B2**
(45) **Date of Patent:** **Apr. 9, 2019**

(54) **MODULAR CONNECTION ASSEMBLY FOR A HEARING ASSISTANCE DEVICE**

(71) Applicant: **Starkey Laboratories, Inc.**, Eden Prairie, MN (US)

(72) Inventors: **Sidney A. Higgins**, Maple Grove, MN (US); **James R. Newton**, Burnsville, MN (US)

(73) Assignee: **Starkey Laboratories, Inc.**, Eden Prairie, MN (US)

(*) Notice: Subject to any disclaimer, the term of this patent is extended or adjusted under 35 U.S.C. 154(b) by 0 days.

(21) Appl. No.: **15/632,742**

(22) Filed: **Jun. 26, 2017**

(65) **Prior Publication Data**

US 2017/0359662 A1 Dec. 14, 2017

Related U.S. Application Data

(63) Continuation of application No. 14/301,103, filed on Jun. 10, 2014, now Pat. No. 9,693,154, which is a (Continued)

(51) **Int. Cl.**
H04R 25/00 (2006.01)
H04R 25/02 (2006.01)

(52) **U.S. Cl.**
CPC **H04R 25/55** (2013.01); **H04R 25/02** (2013.01); **H04R 25/556** (2013.01); **H04R 25/60** (2013.01);

(Continued)

(58) **Field of Classification Search**
CPC **H04R 25/55**
See application file for complete search history.

(56) **References Cited**

U.S. PATENT DOCUMENTS

2,327,320 A 8/1943 Shapiro
3,728,509 A 4/1973 Shimojo
(Continued)

FOREIGN PATENT DOCUMENTS

DE 1247402 8/1967
DE 3006235 A1 10/1980
(Continued)

OTHER PUBLICATIONS

“U.S. Appl. No. 10/894,576, Non-Final Office Action dated Jul. 2, 2007”, 12 pgs.

(Continued)

Primary Examiner — Yogeshkumar Patel

(74) *Attorney, Agent, or Firm* — Schwegman Lundberg & Woessner, P.A.

(57) **ABSTRACT**

The present subject matter relates to an improved connection assembly for hearing assistance devices. The improved connection assembly provides a connection system that is reliable, straightforward to manufacture, and easy to use. The present connection assembly provides a rapid replacement option for the cable and/or the receiver or other electronics connected to the cable. The present subject matter provides for a connection assembly that can be extended to provide connections for a variety of applications which are not limited to a speaker (receiver) in the ear. Sensors and new configurations of component placement are supported using the present assembly, including, but not limited to telecoils, and GMR or TMR sensors. Various electromagnetic interference issues are addressed. In some examples a shielded set of wires are included. In some examples a twisted pair of wires is included. Various combinations of wires for different applications are supported with the present connector system.

20 Claims, 17 Drawing Sheets

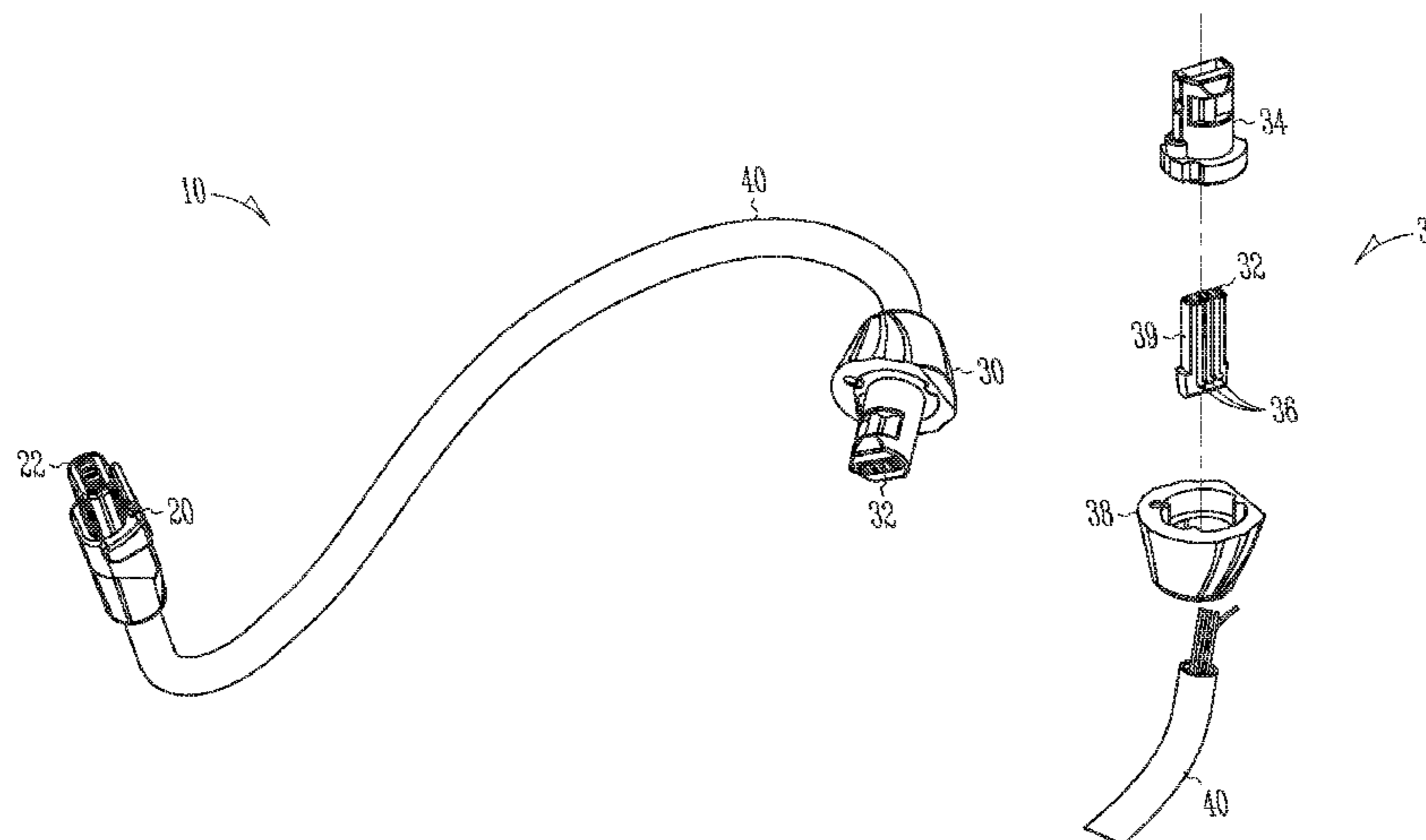

Related U.S. Application Data

continuation of application No. 12/548,051, filed on Aug. 26, 2009, now Pat. No. 8,781,141.

(60) Provisional application No. 61/092,336, filed on Aug. 27, 2008, provisional application No. 61/138,066, filed on Dec. 16, 2008, provisional application No. 61/142,125, filed on Dec. 31, 2008.

(52) **U.S. Cl.**
CPC .. H04R 2225/021 (2013.01); H04R 2225/025 (2013.01)

(56) **References Cited**

U.S. PATENT DOCUMENTS

3,812,300 A 5/1974 Brander et al.
 4,017,834 A 4/1977 Cuttill et al.
 4,310,213 A 1/1982 Fetterolf, Sr. et al.
 4,564,955 A 1/1986 Birch et al.
 4,571,464 A 2/1986 Segero
 4,729,166 A 3/1988 Lee et al.
 5,606,621 A 2/1997 Reiter et al.
 5,640,457 A 6/1997 Gnecco et al.
 5,687,242 A 11/1997 Iburg
 5,708,720 A 1/1998 Meyer
 5,740,261 A 4/1998 Loeppert et al.
 5,755,743 A 5/1998 Volz et al.
 5,802,183 A 9/1998 Scheller et al.
 5,824,968 A 10/1998 Packard et al.
 5,825,894 A 10/1998 Shennib
 5,987,146 A 11/1999 Pluvinage et al.
 6,031,923 A 2/2000 Gnecco et al.
 6,167,138 A 12/2000 Shennib
 6,563,045 B2 5/2003 Goett et al.
 6,766,030 B1 7/2004 Chojar
 6,876,074 B2 4/2005 Kim
 6,985,598 B1 1/2006 Joschika
 7,003,127 B1 2/2006 Sjursen et al.
 7,016,512 B1 3/2006 Feeley et al.
 7,065,224 B2 6/2006 Cornelius et al.
 7,110,562 B1 9/2006 Feeley et al.
 7,139,404 B2 11/2006 Feeley et al.
 7,142,682 B2 11/2006 Mullenborn et al.
 7,181,035 B2 2/2007 Van Halteren et al.
 7,256,747 B2 8/2007 Victorian et al.
 7,320,832 B2 1/2008 Palumbo et al.
 7,354,354 B2 4/2008 Palumbo et al.
 7,446,720 B2 11/2008 Victorian et al.
 7,460,681 B2 12/2008 Geschiere et al.
 7,471,182 B2 12/2008 Kumano et al.
 7,593,538 B2 9/2009 Polinske
 7,720,244 B2 5/2010 Espersen et al.
 8,098,863 B2 1/2012 Ho et al.
 8,103,039 B2 1/2012 Van Halteren et al.
 8,116,495 B2 2/2012 Spaulding
 8,259,975 B2 9/2012 Bally et al.
 8,295,517 B2 10/2012 Gottschalk et al.
 8,385,573 B2 2/2013 Higgins
 8,494,195 B2 7/2013 Higgins
 8,638,965 B2 1/2014 Higgins et al.
 8,705,785 B2 4/2014 Link et al.
 8,781,141 B2 7/2014 Higgins et al.
 8,798,299 B1 8/2014 Higgins et al.
 8,861,761 B2 10/2014 Higgins
 8,908,895 B2 12/2014 Würfel
 9,049,526 B2 6/2015 Higgins
 9,654,887 B2 5/2017 Link et al.
 9,693,154 B2 6/2017 Higgins et al.
 10,051,390 B2 8/2018 Link et al.
 2001/0033664 A1* 10/2001 Poux H04R 25/70
 381/60
 2002/0061113 A1 5/2002 van Halteren et al.
 2002/0074633 A1 6/2002 Larson et al.
 2002/0131614 A1 9/2002 Jakob et al.

2003/0178247 A1 9/2003 Saltykov
 2003/0200820 A1 10/2003 Takada et al.
 2004/0010181 A1* 1/2004 Feeley H04R 25/608
 600/25
 2004/0028251 A1 2/2004 Kasztelan et al.
 2004/0114776 A1 6/2004 Crawford et al.
 2004/0240693 A1 12/2004 Rosenthal
 2005/0008178 A1 1/2005 Joergensen et al.
 2005/0111685 A1 5/2005 Gabathuler
 2006/0008110 A1 1/2006 Van Halteren
 2006/0018495 A1 1/2006 Geschiere et al.
 2006/0078142 A1* 4/2006 Neilson H04R 25/556
 381/323
 2006/0097376 A1 5/2006 Leurs et al.
 2006/0159298 A1 7/2006 Von Dombrowski et al.
 2007/0009130 A1 1/2007 Feeley et al.
 2007/0014423 A1* 1/2007 Darbut H04R 25/65
 381/330
 2007/0036374 A1 2/2007 Bauman et al.
 2007/0121979 A1 5/2007 Zhu et al.
 2007/0147630 A1 6/2007 Chiloyan
 2007/0188289 A1 8/2007 Kumano et al.
 2007/0248234 A1 10/2007 Ho et al.
 2008/0003736 A1 1/2008 Arai et al.
 2008/0026220 A9 1/2008 Bi et al.
 2008/0187157 A1 8/2008 Higgins
 2008/0199971 A1 8/2008 Tondra
 2008/0260193 A1 10/2008 Westermann et al.
 2009/0074218 A1 3/2009 Higgins
 2009/0075083 A1 3/2009 Bi et al.
 2009/0196444 A1* 8/2009 Solum H01Q 1/273
 381/315
 2009/0245558 A1 10/2009 Spaulding
 2009/0252365 A1 10/2009 Lin
 2009/0262964 A1 10/2009 Havenith et al.
 2010/0034410 A1 2/2010 Douglas et al.
 2010/0074461 A1 3/2010 Polinske
 2010/0124346 A1 5/2010 Higgins
 2010/0135513 A1 6/2010 Geschiere et al.
 2010/0158291 A1 6/2010 Polinske et al.
 2010/0158293 A1 6/2010 Polinske et al.
 2010/0158295 A1 6/2010 Polinske et al.
 2011/0044485 A1 2/2011 Lin et al.
 2012/0014549 A1 1/2012 Higgins et al.
 2012/0263328 A1 10/2012 Higgins
 2013/0230197 A1 9/2013 Higgins
 2014/0355803 A1 12/2014 Higgins et al.
 2015/0086051 A1 3/2015 Link et al.
 2015/0163601 A1 6/2015 Higgins
 2017/0318402 A1 11/2017 Link et al.

FOREIGN PATENT DOCUMENTS

DE 3502178 A1 8/1985
 DE 3643124 A1 7/1988
 DE 4005476 A1 7/1991
 DE 9320391 U1 9/1993
 DE 4233813 C1 11/1993
 DE 9408054 U1 5/1994
 DE 29801567 U1 5/1998
 DE 102008045668 A1 9/2008
 EP 0339877 A3 11/1989
 EP 0424916 B1 7/1995
 EP 0866637 A2 9/1998
 EP 1065863 A2 1/2001
 EP 1209948 A2 5/2002
 EP 1465457 A2 10/2004
 EP 1496530 A2 1/2005
 EP 1209948 A3 7/2006
 EP 1811808 A1 7/2007
 EP 1816893 A1 8/2007
 EP 1850630 A2 10/2007
 EP 1916561 A2 4/2008
 EP 1916561 A3 4/2008
 EP 1920634 B1 2/2009
 EP 2040343 A1 3/2009
 EP 2107829 B1 5/2012
 EP 2509341 A1 10/2012

(56)

References Cited

FOREIGN PATENT DOCUMENTS

EP	2160047	B1	10/2013
EP	2509341	B1	6/2014
GB	1298089		11/1972
GB	1522549		8/1978
GB	1522549	B3	8/1978
JP	2209967	A	8/1990
JP	2288116	A	11/1990
JP	09199662	A	7/1997
WO	WO-9741710	A1	11/1997
WO	WO-0079832	A2	12/2000
WO	WO-0143497	A1	6/2001
WO	WO-2004025990	A1	3/2004
WO	WO-06094502	A1	9/2006
WO	WO-2006094502	A1	9/2006
WO	WO-2007027152	A1	3/2007
WO	WO-2007112404	A2	10/2007
WO	WO 2007112404	A3	10/2007
WO	WO-2007140403	A2	12/2007
WO	WO-2007140403	A3	12/2007
WO	WO 2007148154	A1	12/2007
WO	WO-2008092265	A1	8/2008
WO	WO-2008097600	A1	8/2008
WO	WO-2008097600	C1	8/2008
WO	WO-2011101041	A1	8/2011

OTHER PUBLICATIONS

“U.S. Appl. No. 10/894,576, Non-Final Office Action dated Dec. 18, 2007”, 11 pgs.
 “U.S. Appl. No. 10/894,576, Notice of Allowance dated Aug. 5, 2008”, 7 pgs.
 “U.S. Appl. No. 10/894,576, Response filed Apr. 18, 2008 to Non-Final Office Action dated Dec. 18, 2007”, 10 pgs.
 “U.S. Appl. No. 10/894,576, Response filed Oct. 1, 2007 to Non-Final Office Action dated Jul. 2, 2007”, 10 pgs.
 “U.S. Appl. No. 11/857,439, Final Office Action dated Feb. 29, 2012”, 16 pgs.
 “U.S. Appl. No. 11/857,439, Non Final Office Action dated Aug. 17, 2011”, 16 pgs.
 “U.S. Appl. No. 11/857,439, Notice of Allowance dated May 30, 2012”, 9 pgs.
 “U.S. Appl. No. 11/857,439, Notice of Allowance dated Sep. 19, 2012”, 9 pgs.
 “U.S. Appl. No. 11/857,439, Response filed Apr. 30, 2012 to Final Office Action dated Feb. 29, 2012”, 9 pgs.
 “U.S. Appl. No. 11/857,439, Response filed Jun. 13, 2011 to Restriction Requirement dated May 11, 2011”, 8 pgs.
 “U.S. Appl. No. 11/857,439, Response filed Dec. 17, 2011 to Non Final Office Action dated Aug. 17, 2011”, 12 pgs.
 “U.S. Appl. No. 11/857,439, Restriction Requirement dated May 11, 2011”, 6 pgs.
 “U.S. Appl. No. 12/027,173, Final Office Action dated Dec. 8, 2011”, 12 pgs.
 “U.S. Appl. No. 12/027,173, Non Final Office Action dated Jul. 11, 2011”, 10 pgs.
 “U.S. Appl. No. 12/027,173, Non Final Office Action dated Jul. 27, 2012”, 11 pgs.
 “U.S. Appl. No. 12/027,173, Notice of Allowance dated Mar. 19, 2013”, 8 pgs.
 “U.S. Appl. No. 12/027,173, Response filed Jun. 8, 2012 to Final Office Action dated Dec. 8, 2011”, 7 pgs.
 “U.S. Appl. No. 12/027,173, Response filed Nov. 14, 2011 to Non Final Office Action dated Jul. 11, 2011”, 8 pgs.
 “U.S. Appl. No. 12/027,173, Response filed Dec. 26, 2012 to Non Final Office Action dated Jul. 27, 2012”, 8 pgs.
 “U.S. Appl. No. 12/059,578, Notice of Allowance dated Oct. 5, 2011”, 8 pgs.
 “U.S. Appl. No. 12/325,838, Non Final Office Action dated Jun. 16, 2011”, 5 pgs.

“U.S. Appl. No. 12/539,195, Advisory Action dated Apr. 23, 2013”, 3 pgs.
 “U.S. Appl. No. 12/539,195, Final Office Action dated Feb. 11, 2013”, 15 pgs.
 “U.S. Appl. No. 12/539,195, Non Final Office Action dated Jul. 20, 2012”, 13 pgs.
 “U.S. Appl. No. 12/539,195, Non Final Office Action dated Aug. 2, 2013”, 14 pgs.
 “U.S. Appl. No. 12/539,195, Notice of Allowance dated Nov. 29, 2013”, 12 pgs.
 “U.S. Appl. No. 12/539,195, Response filed Apr. 11, 2013 to Final Office Action dated Feb. 11, 2013”, 7 pgs.
 “U.S. Appl. No. 12/539,195, Response filed Nov. 4, 2013 to Non Final Office Action dated Aug. 2, 2013”, 7 pgs.
 “U.S. Appl. No. 12/539,195, Response filed Dec. 20, 2012 to Non Final Office Action dated Jul. 20, 2012”, 7 pgs.
 “U.S. Appl. No. 12/548,051, Final Office Action dated Apr. 19, 2012”, 12 pgs.
 “U.S. Appl. No. 12/548,051, Non Final Office Action dated Jan. 24, 2013”, 12 pgs.
 “U.S. Appl. No. 12/548,051, Non Final Office Action dated Oct. 12, 2011”, 11 pgs.
 “U.S. Appl. No. 12/548,051, Notice of Allowance dated Jul. 31, 2013”, 14 pgs.
 “U.S. Appl. No. 12/548,051, Response filed Jan. 12, 2012 to Non Final Office Action dated Oct. 12, 2011”, 9 pgs.
 “U.S. Appl. No. 12/548,051, Response filed Apr. 24, 2013 to Non Final Office Action dated Jan. 24, 2013”, 8 pgs.
 “U.S. Appl. No. 12/548,051, Response filed Sep. 19, 2012 to Final Office Action dated Apr. 19, 2012”, 8 pgs.
 “U.S. Appl. No. 12/644,188, Advisory Action dated Jul. 25, 2013”, 3 pgs.
 “U.S. Appl. No. 12/644,188, Final Office Action dated May 22, 2013”, 7 pgs.
 “U.S. Appl. No. 12/644,188, Non Final Office Action dated Sep. 9, 2013”, 9 pgs.
 “U.S. Appl. No. 12/644,188, Non Final Office Action dated Sep. 19, 2012”, 8 pgs.
 “U.S. Appl. No. 12/644,188, Notice of Allowance dated Mar. 21, 2014”, 5 pgs.
 “U.S. Appl. No. 12/644,188, Response filed Feb. 19, 2013 to Non Final Office Action dated Sep. 19, 2012”, 6 pgs.
 “U.S. Appl. No. 12/644,188, Response filed Jul. 22, 2013 to Final Office Action dated May 22, 2013”, 6 pgs.
 “U.S. Appl. No. 12/644,188, Response filed Dec. 9, 2013 to Non Final Office Action dated Sep. 9, 2013”, 6 pgs.
 “U.S. Appl. No. 12/842,305, Examiner Interview Summary dated Apr. 19, 2013”, 3 pgs.
 “U.S. Appl. No. 12/842,305, Non Final Office Action dated Jan. 17, 2014”, 8 pgs.
 “U.S. Appl. No. 12/842,305, Response filed Apr. 8, 2013 to Restriction Requirement dated Feb. 8, 2013”, 6 pgs.
 “U.S. Appl. No. 12/842,305, Response filed Apr. 17, 2014 to Non Final Office Action dated Jan. 17, 2014”, 9 pgs.
 “U.S. Appl. No. 12/842,305, Restriction Requirement dated Feb. 8, 2013”, 6 pgs.
 “U.S. Appl. No. 13/181,752, Final Office Action dated Jul. 11, 2013”, 7 pgs.
 “U.S. Appl. No. 13/181,752, Non Final Office Action dated Mar. 5, 2013”, 7 pgs.
 “U.S. Appl. No. 13/181,752, Notice of Allowance dated Sep. 25, 2013”, 9 pgs.
 “U.S. Appl. No. 13/181,752, Response filed Jun. 5, 2013 to Non Final Office Action dated Mar. 5, 2013”, 8 pgs.
 “U.S. Appl. No. 13/181,752, Response filed Sep. 11, 2013 to Final Office Action dated Jul. 11, 2013”, 8 pgs.
 “U.S. Appl. No. 13/422,177, Advisory Action dated Jun. 9, 2014”, 3 pgs.
 “U.S. Appl. No. 13/422,177, Final Office Action dated Feb. 27, 2014”, 12 pgs.
 “U.S. Appl. No. 13/422,177, Non Final Office Action dated Jul. 16, 2014”, 12 pgs.

(56)

References Cited

OTHER PUBLICATIONS

“U.S. Appl. No. 13/422,177, Non Final Office Action dated Sep. 26, 2013”, 10 pgs.
 “U.S. Appl. No. 13/422,177, Notice of Allowance dated Feb. 3, 2015”, 8 pgs.
 “U.S. Appl. No. 13/422,177, Response filed Apr. 28, 2014 to Final Office Action dated Feb. 27, 2014”, 9 pgs.
 “U.S. Appl. No. 13/422,177, Response filed Oct. 16, 2014 to Non Final Office Action dated Jul. 16, 2014”, 10 pgs.
 “U.S. Appl. No. 13/422,177, Response filed Dec. 20, 2013 to Non Final Office Action dated Sep. 26, 2013”, 8 pgs.
 “U.S. Appl. No. 13/776,557, Final Office Action dated Mar. 20, 2014”, 8 pgs.
 “U.S. Appl. No. 13/776,557, Non Final Office Action dated Oct. 22, 2013”, 6 pgs.
 “U.S. Appl. No. 13/776,557, Notice of Allowance dated Jun. 13, 2014”, 8 pgs.
 “U.S. Appl. No. 13/776,557, Response filed Jan. 22, 2014 to Non Final Office Action dated Oct. 22, 2013”, 6 pgs.
 “U.S. Appl. No. 13/776,557, Response filed May 15, 2014 to Final Office Action dated Mar. 20, 2014”, 7 pgs.
 “U.S. Appl. No. 14/257,537, Advisory Action dated Jul. 14, 2016”, 6 pgs.
 “U.S. Appl. No. 14/257,537, Advisory Action dated Oct. 21, 2015”, 2 pgs.
 “U.S. Appl. No. 14/257,537, Appeal Brief filed Oct. 27, 2016”, 15 pgs.
 “U.S. Appl. No. 14/257,537, Decision dated Aug. 15, 2016 on Pre-Appeal Brief Request filed Jul. 27, 2016”, 4 pgs.
 “U.S. Appl. No. 14/257,537, Final Office Action dated Apr. 27, 2016”, 20 pgs.
 “U.S. Appl. No. 14/257,537, Final Office Action dated Aug. 3, 2015”, 16 pgs.
 “U.S. Appl. No. 14/257,537, Non Final Office Action dated Mar. 19, 2015”, 19 pgs.
 “U.S. Appl. No. 14/257,537, Non Final Office Action dated Nov. 17, 2015”, 20 pgs.
 “U.S. Appl. No. 14/257,537, Pre-Appeal Brief Request filed Jul. 27, 2016”, 4 pgs.
 “U.S. Appl. No. 14/257,537, Response filed Feb. 17, 2016 to Non Final Office Action dated Nov. 17, 2015”, 19 pgs.
 “U.S. Appl. No. 14/257,537, Response filed Jun. 19, 2015 to Non Final Office Action dated Mar. 19, 2015”, 6 pgs.
 “U.S. Appl. No. 14/257,537, Response filed Jun. 27, 2016 to Final Office Action dated Apr. 27, 2016”, 8 pgs.
 “U.S. Appl. No. 14/257,537, Response filed Oct. 5, 2015 to Final Office Action dated Aug. 3, 2015”, 8 pgs.
 “U.S. Appl. No. 14/257,537, Response filed Nov. 3, 2015 to Advisory Action dated Oct. 21, 2015”, 8 pgs.
 “U.S. Appl. No. 14/301,103, Advisory Action dated Jun. 10, 2016”, 3 pgs.
 “U.S. Appl. No. 14/301,103, Final Office Action dated Mar. 25, 2016”, 11 pgs.
 “U.S. Appl. No. 14/301,103, Non Final Office Action dated Dec. 2, 2015”, 9 pgs.
 “U.S. Appl. No. 14/301,103, Non-Final Office Action dated Jul. 28, 2016”, 10 pgs.
 “U.S. Appl. No. 14/301,103, Notice of Allowance dated Feb. 15, 2017”, 8 pgs.
 “U.S. Appl. No. 14/301,103, Preliminary Amendment Filed Jul. 1, 2014”, 5 pgs.
 “U.S. Appl. No. 14/301,103, Response filed Mar. 2, 2016 to Non Final Office Action dated Dec. 2, 2015”, 6 pgs.
 “U.S. Appl. No. 14/301,103, Response filed May 25, 2016 to Final Office Action dated Mar. 25, 2016”, 7 pgs.
 “U.S. Appl. No. 14/301,103, Response filed Oct. 28, 2016 to Non-Final Office Action dated Jul. 28, 2016”, 6 pgs.
 “U.S. Appl. No. 14/512,560, Non Final Office Action dated Jan. 29, 2016”, 9 pgs.

“U.S. Appl. No. 15/595,302, Preliminary Amendment filed Jul. 24, 2017”, 5 pgs.
 “European Application Serial No. 12167845.2, Extended EP Search Report dated Sep. 12, 2012”, 6 pgs.
 “European Application Serial No. 08253065.0, European Examination Notification dated Oct. 11, 2011”, 7 pgs.
 “European Application Serial No. 08253065.0, European Office Action dated Aug. 26, 2010”, 6 Pgs.
 “European Application Serial No. 08253065.0, Extended Search Report dated Dec. 15, 2008”, 9 pgs.
 “European Application Serial No. 08253065.0, Office Action dated Jul. 17, 2009”, 1 pg.
 “European Application Serial No. 08253065.0, Response filed Jan. 26, 2010 to Office Action dated Jul. 17, 2009”, 9 pgs.
 “European Application Serial No. 08253065.0, Response filed Feb. 8, 2012 to Examination Notification dated Oct. 11, 2011”, 15 pgs.
 “European Application Serial No. 08253065.0, Response to Office Action filed Feb. 28, 2011 to European Office Action dated Aug. 26, 2010”, 17 pgs.
 “European Application Serial No. 08725262.3, EPO Written Decision to Refuse dated Oct. 19, 2012”, 14 pgs.
 “European Application Serial No. 08725262.3, Office Action dated Apr. 21, 2010”, 6 Pgs.
 “European Application Serial No. 08725262.3, Office Action dated Aug. 5, 2011”, 5 pgs.
 “European Application Serial No. 08725262.3, Response filed Feb. 13, 2012 to Office Action dated Aug. 5, 2011”, 11 pgs.
 “European Application Serial No. 08725262.3, Response Filed Nov. 2, 2010 to Office Action dated Apr. 21, 2010”, 14 pgs.
 “European Application Serial No. 08725262.3, Summons to Attend Oral Proceedings dated Jun. 6, 2012”, 5 pgs.
 “European Application Serial No. 09168844.0, European Search Report dated Apr. 19, 2010”, 3 Pgs.
 “European Application Serial No. 09168844.0, Office Action dated Apr. 8, 2013”, 5 pgs.
 “European Application Serial No. 09168844.0, Office Action dated Apr. 28, 2011”, 5 pgs.
 “European Application Serial No. 09168844.0, Office Action dated May 14, 2012”, 2 pgs.
 “European Application Serial No. 09168844.0, Office Action dated May 3, 2010”, 5 pgs.
 “European Application Serial No. 09168844.0, Response filed Feb. 24, 2012 to Office Action dated Apr. 28, 2011”, 12 pgs.
 “European Application Serial No. 09168844.0, Response filed Jul. 24, 2012 to Examination Notification Art. 94(3) dated May 14, 2012”, 10 pgs.
 “European Application Serial No. 09168844.0, Response Filed Nov. 15, 2010 to Office Action dated May 3, 2010”, 8 pgs.
 “European Application Serial No. 09250729.2, Extended Search Report dated Dec. 14, 2009”, 4 pgs.
 “European Application Serial No. 10251319.9, Office Action dated Jan. 3, 2012”, 6 pgs.
 “European Application Serial No. 10251319.9, Response filed Jul. 24, 2012 to Extended European Search Report dated Jan. 3, 2012”, 10 pgs.
 “European Application Serial No. 12160102.5, Extended European Search Report dated Aug. 7, 2016”, 8 pgs.
 “European Application Serial No. 12167845.2, Response filed Apr. 10, 2013 to Extended European Search Report dated Sep. 12, 2012”, 14 pgs.
 “European Application Serial No. 09168844.0, Office Action dated Sep. 4, 2012”, 4 pgs.
 “European Application Serial No. 09168844.0, Response filed Mar. 14, 2013 to Office Action dated Sep. 4, 2012”, 34 pgs.
 “International Application Serial No. PCT/US2008/001609, International Preliminary Report on Patentability dated Aug. 20, 2009”, 10 pgs.
 “International Application Serial No. PCT/US2008/001609, Search Report dated Jun. 19, 2008”, 7 pgs.
 “International Application Serial No. PCT/US2008/001609, Written Opinion dated Jun. 19, 2008”, 8 pgs.
 Buchoff, L S, “Advanced Non-Soldering Interconnection”, Electro International, 1991 (IEEE), XP 10305250A1, (1991), 248-251.

(56)

References Cited

OTHER PUBLICATIONS

“U.S. Appl. No. 14/257,537, Notice of Allowance dated Jan. 13, 2017”, 10 pgs.
Tondra, Mark, “Flow Assay With Integrated Detector”, U.S. Appl. No. 60/887,609, filed Feb. 1, 2007, 28 pgs.
U.S. Appl. No. 12/027,173 U.S. Pat. No. 8,494,195, filed Feb. 6, 2008, Electrical Contacts Using Conductive Silicone in Hearing Assistance Devices.
U.S. Appl. No. 13/948,031, filed Jul. 22, 2013, Electrical Contacts Using Conductive Silicone in Hearing Assistance Devices.
U.S. Appl. No. 11/857,439 U.S. Pat. No. 8,385,573, filed Sep. 19, 2007, System for Hearing Assistance Device Including Receiver in the Canal.
U.S. Appl. No. 13/776,557 U.S. Pat. No. 8,861,761, filed Feb. 25, 2013, System for Hearing Assistance Device Including Receiver in the Canal.
U.S. Appl. No. 14/512,560, filed Oct. 13, 2014, System for Hearing Assistance Device Including Receiver in the Canal.
U.S. Appl. No. 14/257,537 U.S. Pat. No. 9,654,887, filed Apr. 21, 2014, Hearing Aid Adapted for Embedded Electronics.
U.S. Appl. No. 15/595,302, filed May 15, 2017, Hearing Aid Adapted for Embedded Electronics.
U.S. Appl. No. 12/539,195 U.S. Pat. No. 8,705,785, filed Aug. 11, 2009, Hearing Aid Adapted for Embedded Electronics.

U.S. Appl. No. 12/644,188 U.S. Pat. No. 8,798,299, filed Dec. 22, 2009, Magnetic Shielding for Communication Device Applications.
U.S. Appl. No. 12/548,051 U.S. Pat. No. 8,781,141, filed Aug. 26, 2009, Modular Connection Assembly for a Hearing Assistance Device.
U.S. Appl. No. 14/301,103 U.S. Pat. No. 9,693,154, filed Jun. 10, 2014, Modular Connection Assembly for a Hearing Assistance Device.
U.S. Appl. No. 13/181,752 U.S. Pat. No. 8,638,965, filed Jul. 13, 2011, Receiver-in-Canal Hearing Device Cable Connections.
U.S. Appl. No. 14/141,725, filed Dec. 27, 2013, Receiver-in-Canal Hearing Device Cable Connections.
U.S. Appl. No. 13/422,177 U.S. Pat. No. 9,049,526, filed Mar. 16, 2012, Compact Programming Block Connector For Hearing Assistance Devices.
“U.S. Appl. No. 15/595,302, Non Final Office Action dated Nov. 30, 2017”, 19 pgs.
“U.S. Appl. No. 15/595,302, Notice of Allowance dated Apr. 11, 2018”, 10 pgs.
“U.S. Appl. No. 15/595,302, Response filed Feb. 28, 2018 to Non Final Office Action dated Nov. 30, 2017”, 7 pgs.
“U.S. Appl. No. 16/058,335, Non Final Office Action dated Oct. 11, 2018”, 19 pgs.
“U.S. Appl. No. 16/058,335, Preliminary Amendment”, 5 pgs.
“European Application Serial No. 12160102.5, Communication Pursuant to Article 94(3) EPC dated Jul. 17, 2018”, 6 pgs.

* cited by examiner

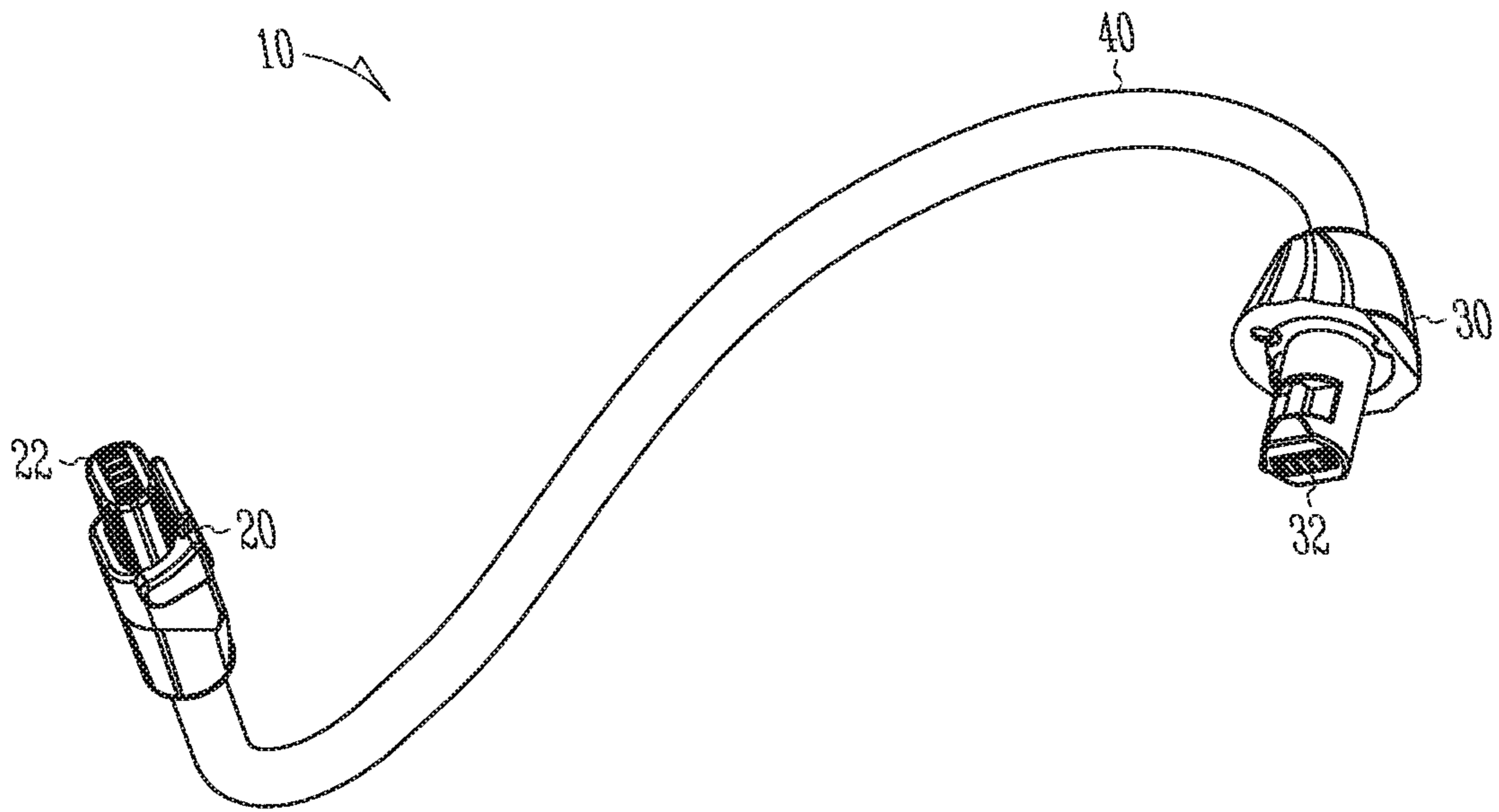

Fig. 1

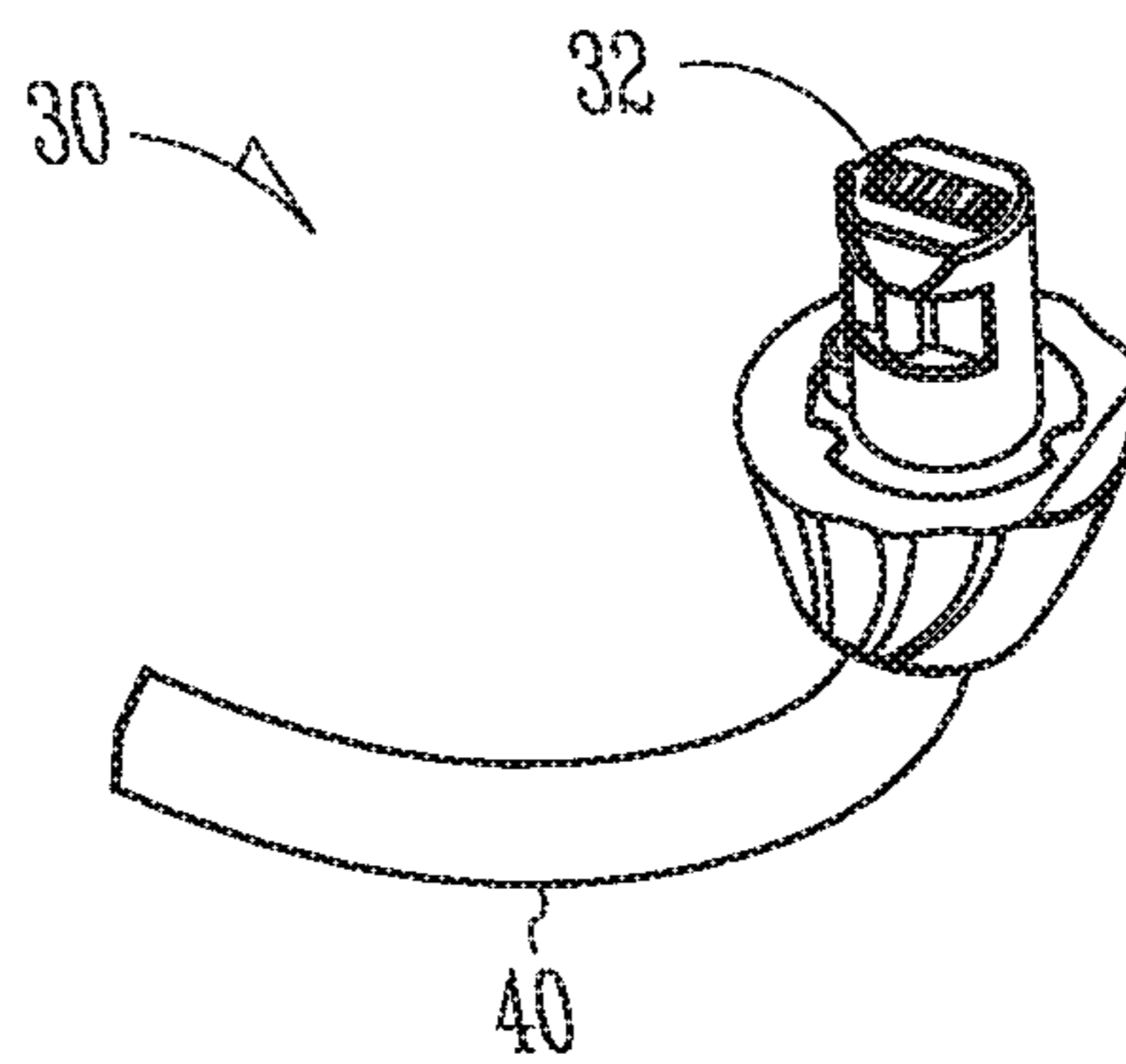

Fig. 2

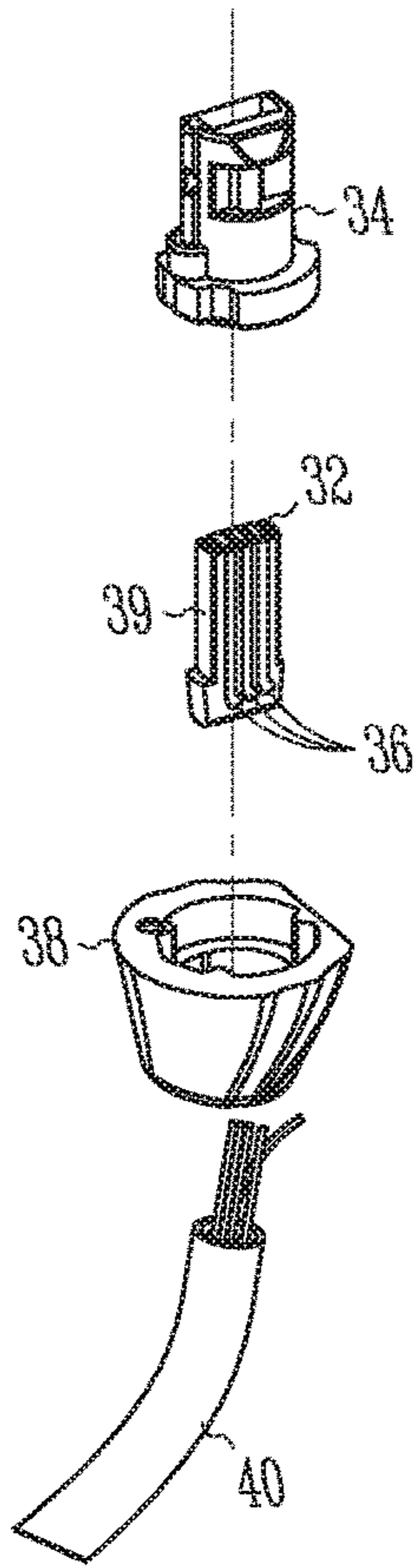

Fig. 3

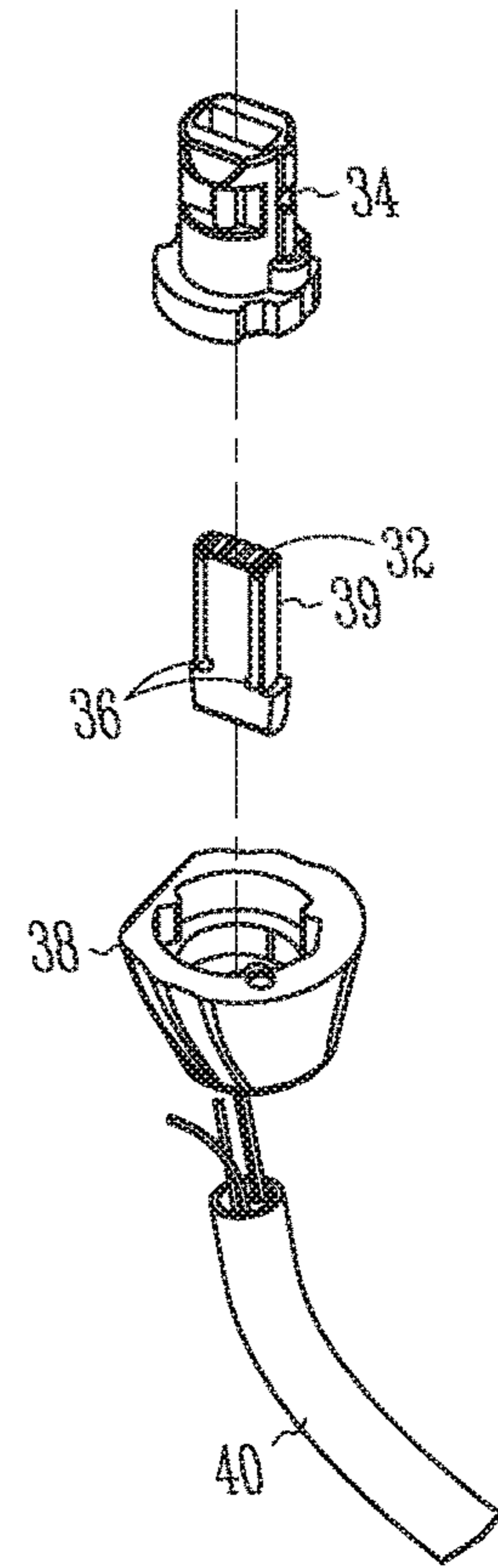

Fig. 4

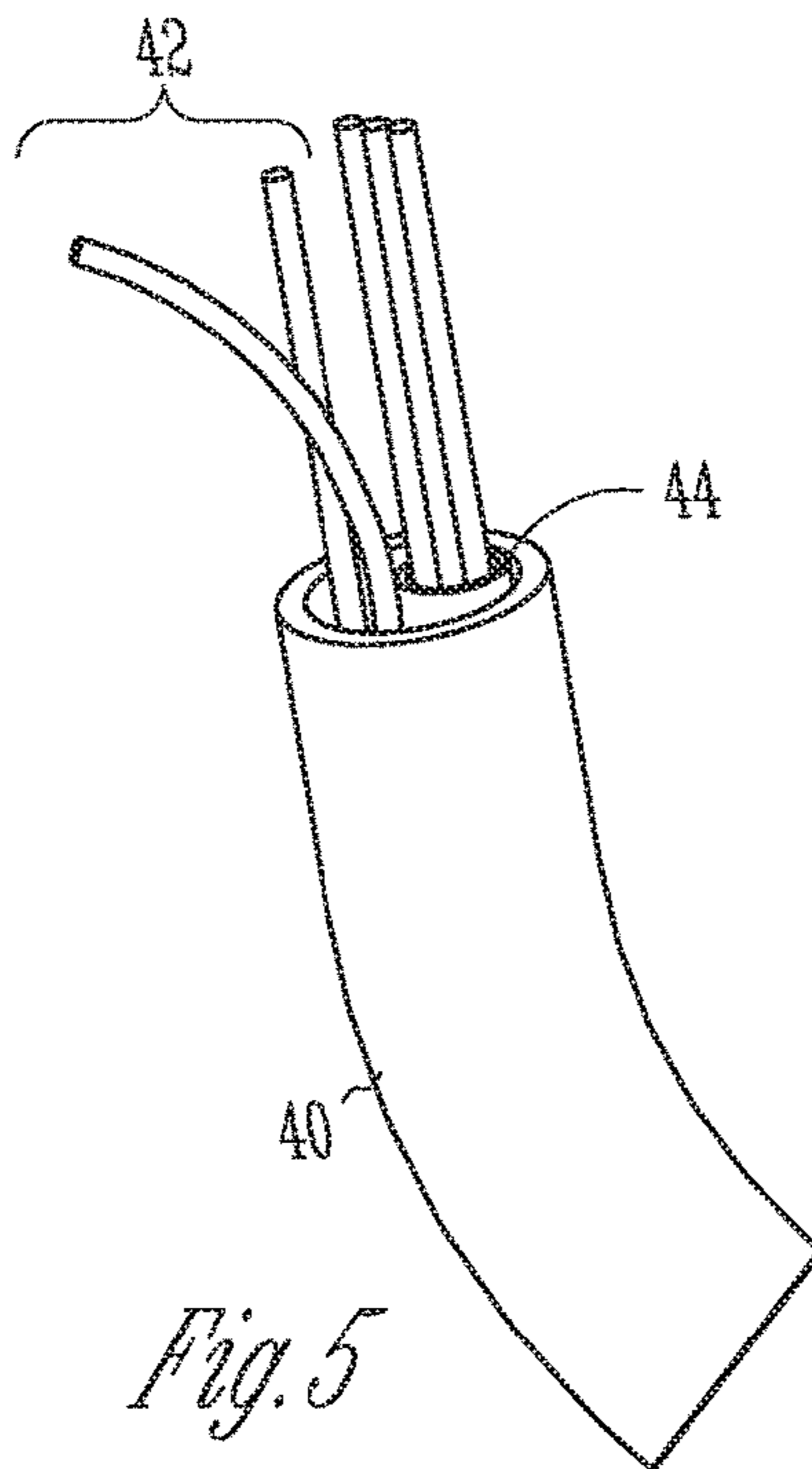

Fig. 5

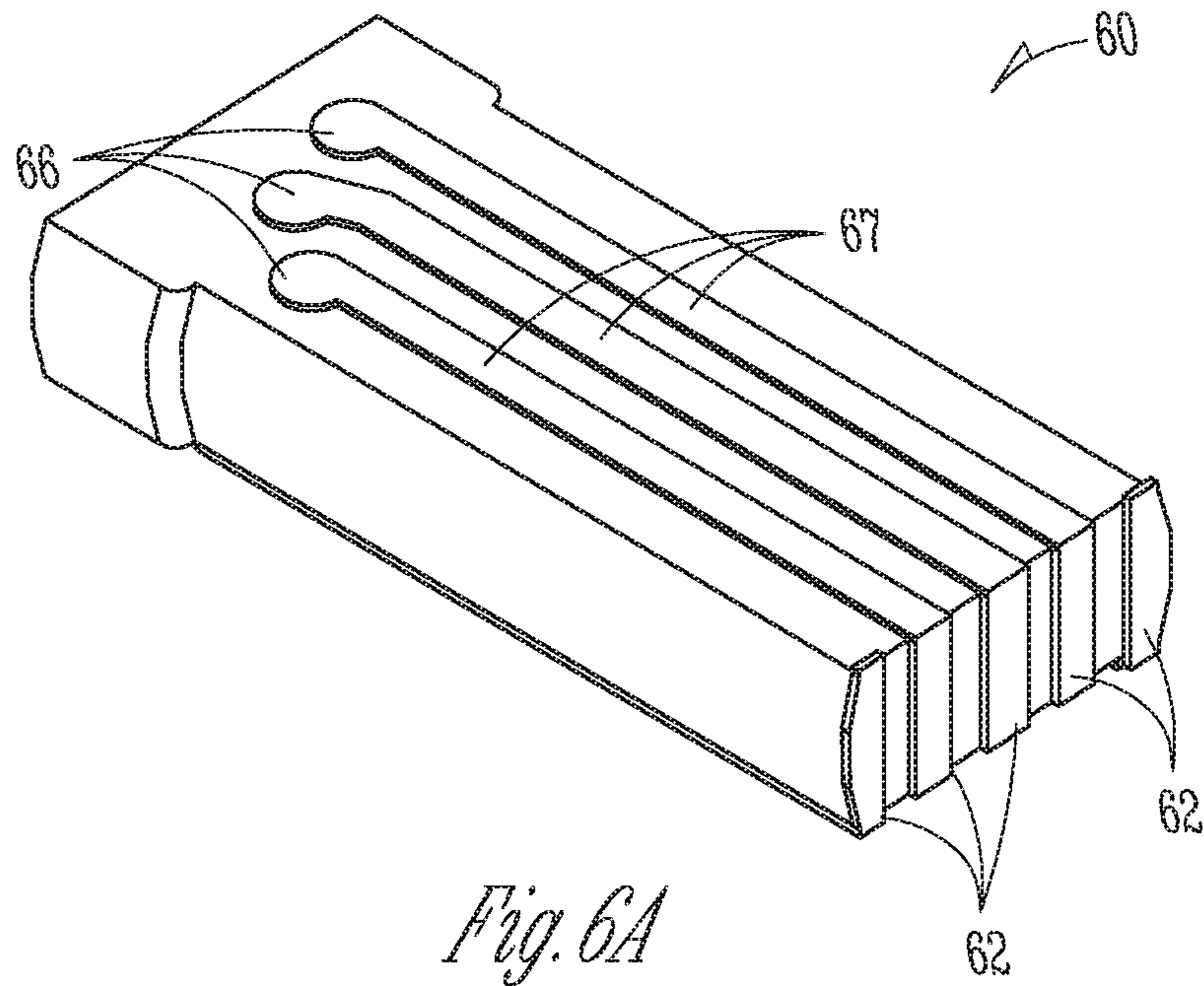

Fig. 6A

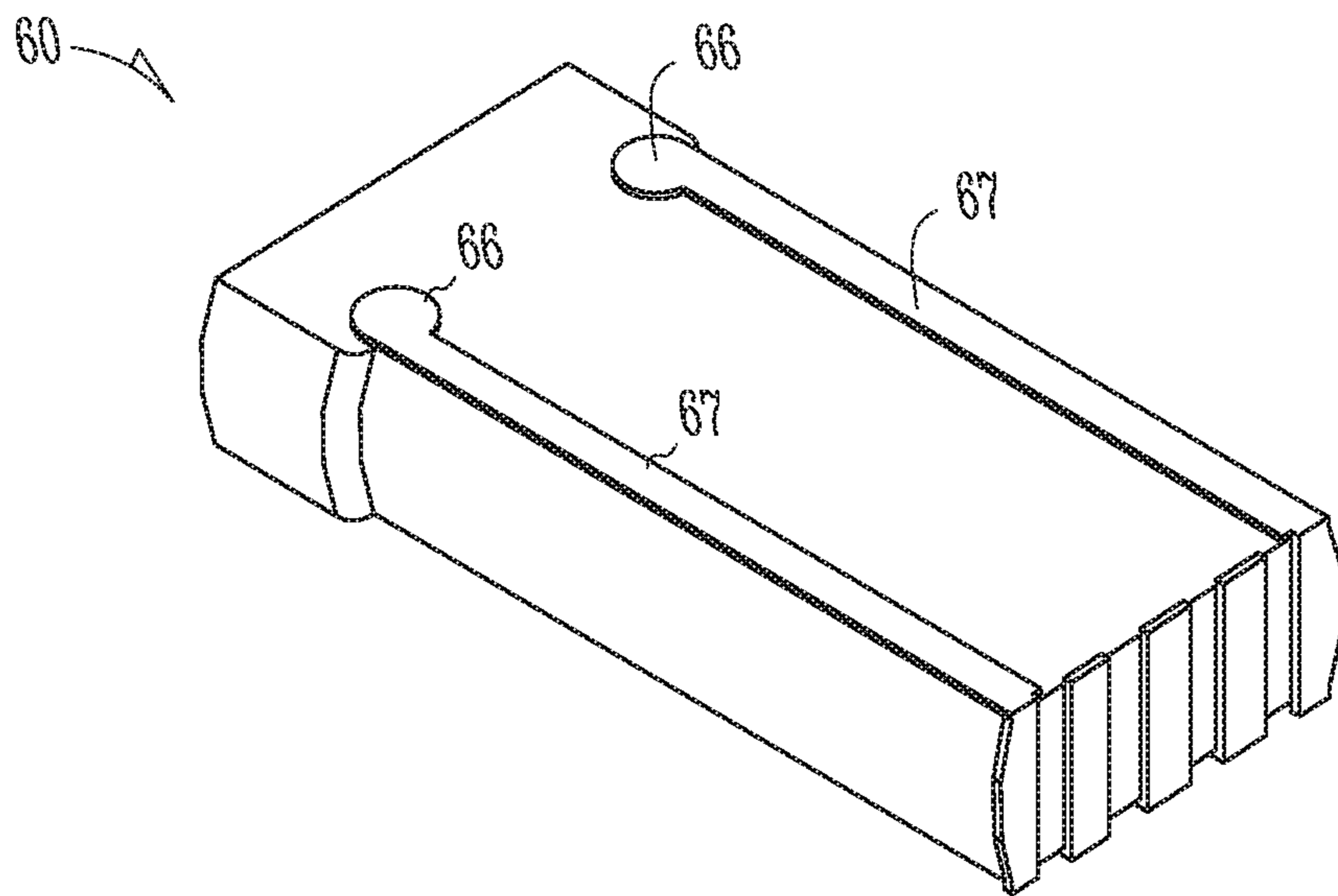

Fig. 6B

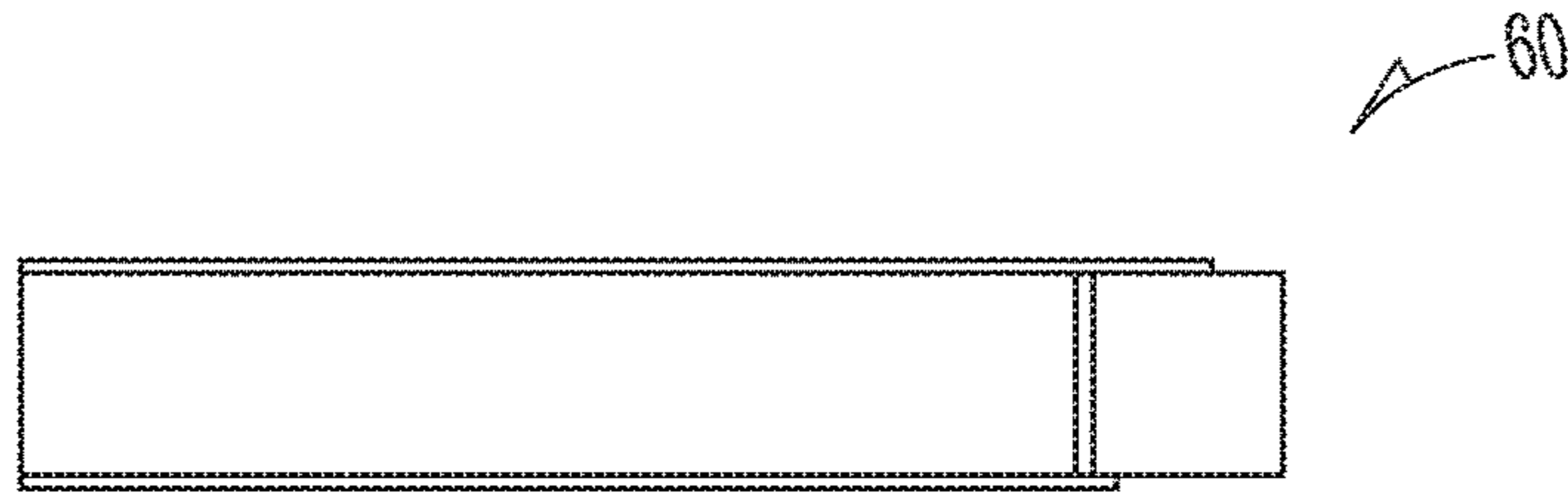

Fig. 6C

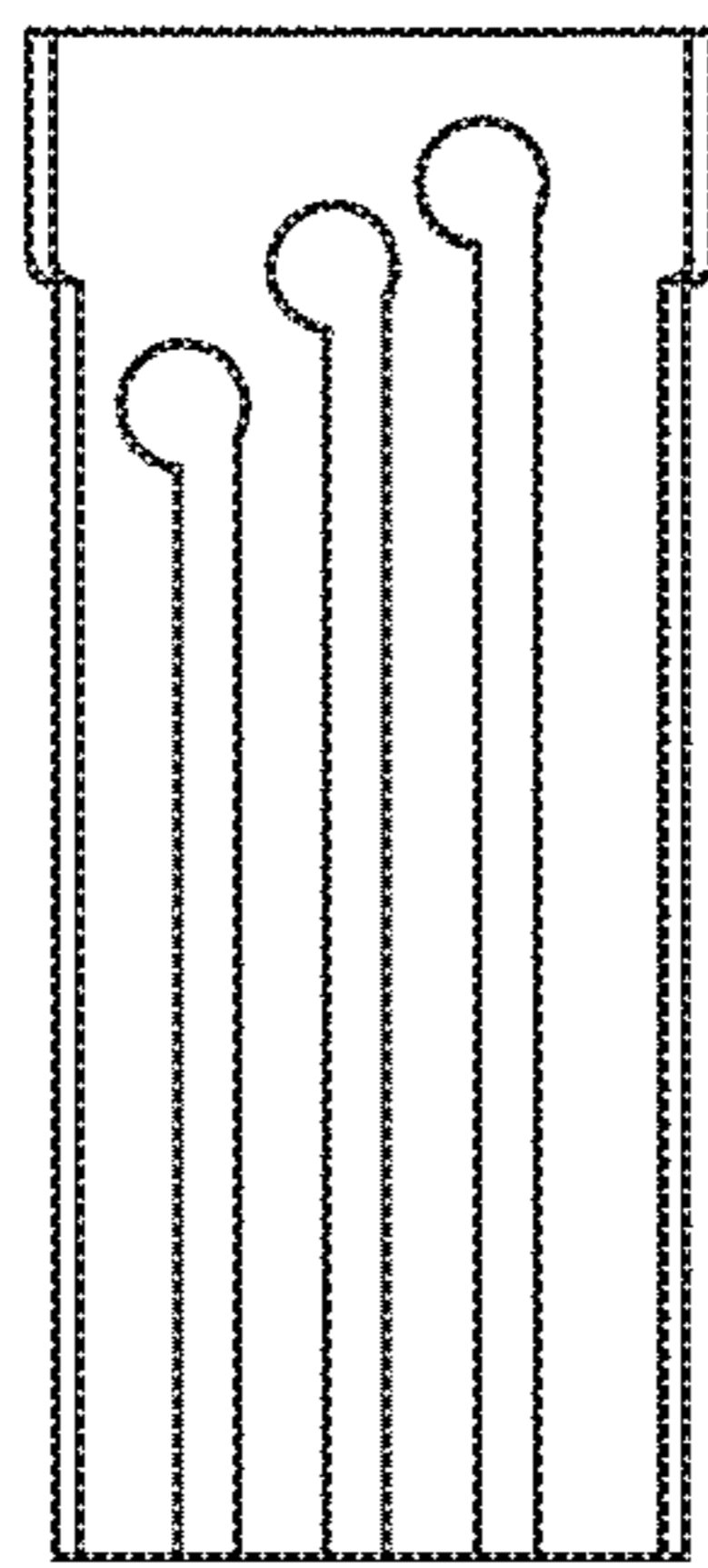

Fig. 6D

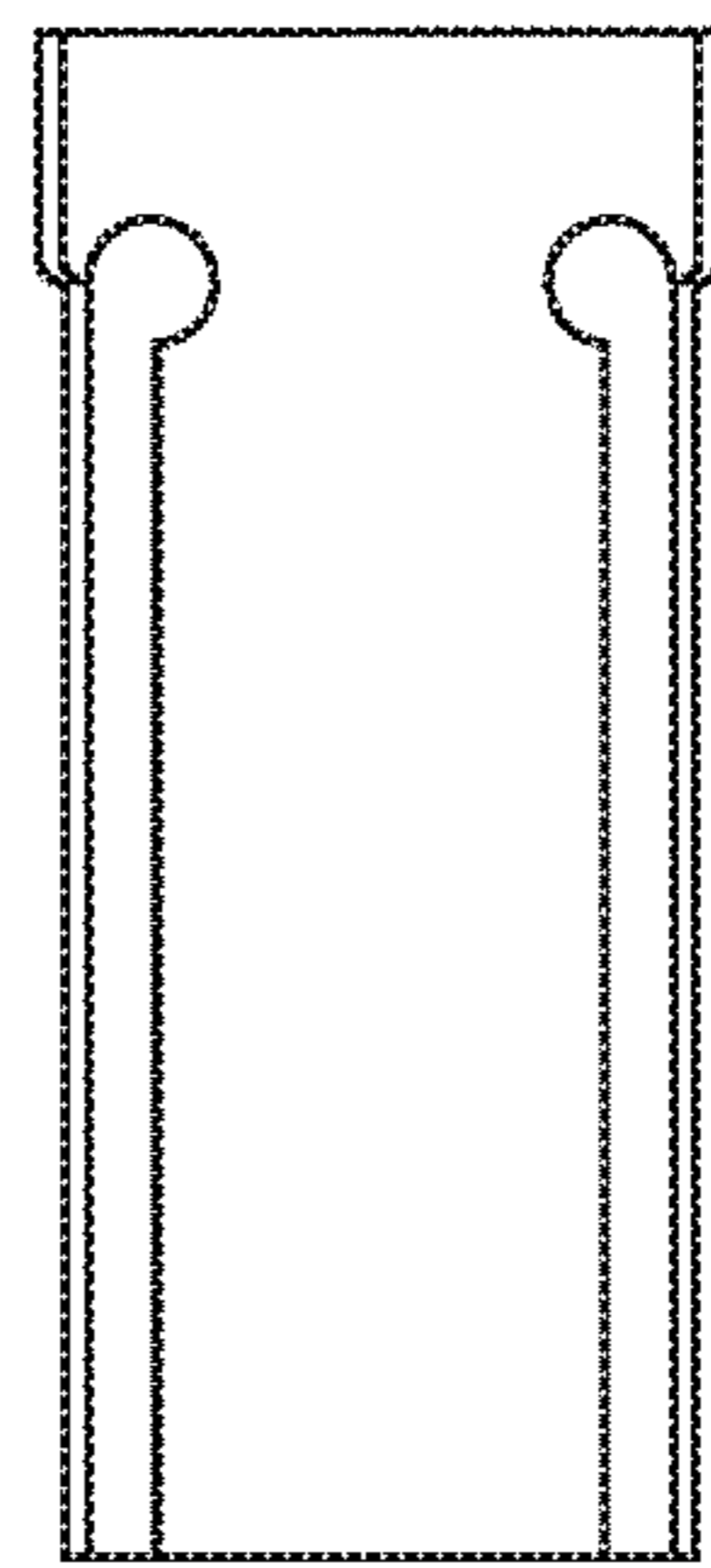

Fig. 6E

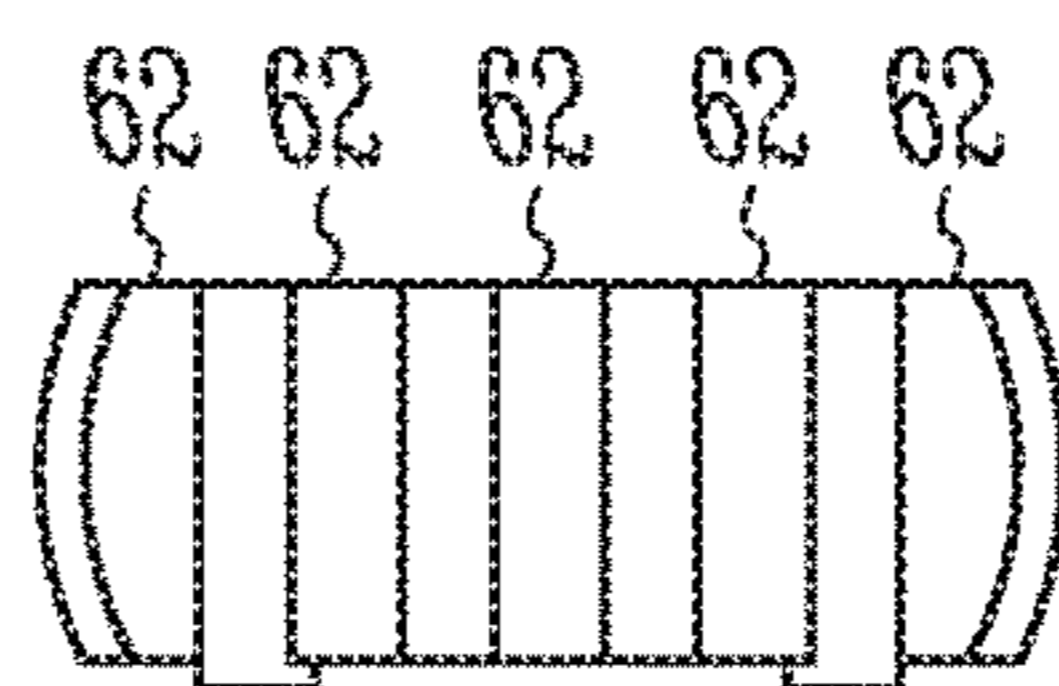

Fig. 6F

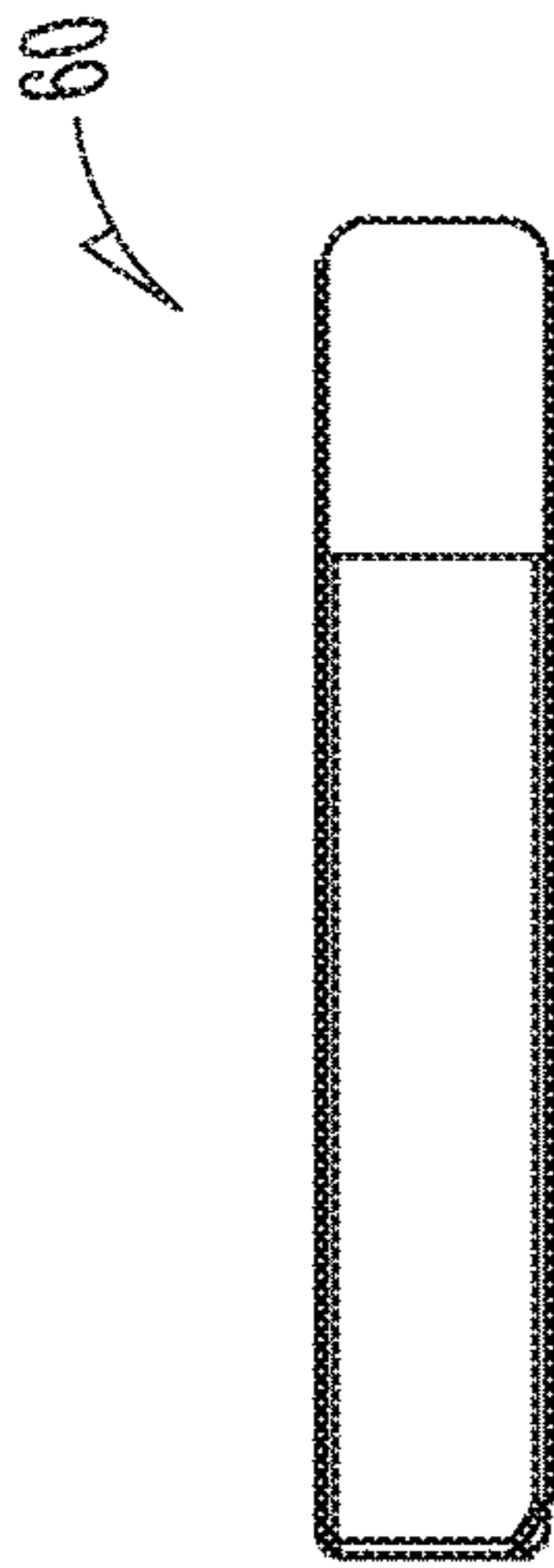

Fig. 6I

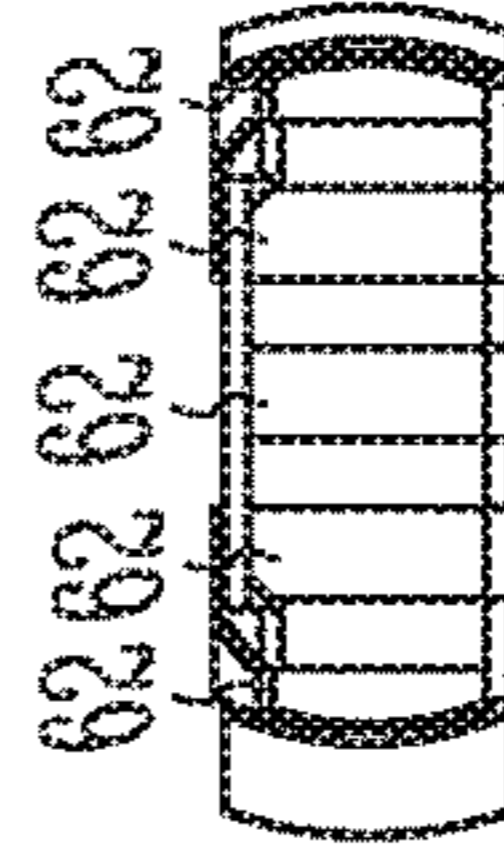

Fig. 6L

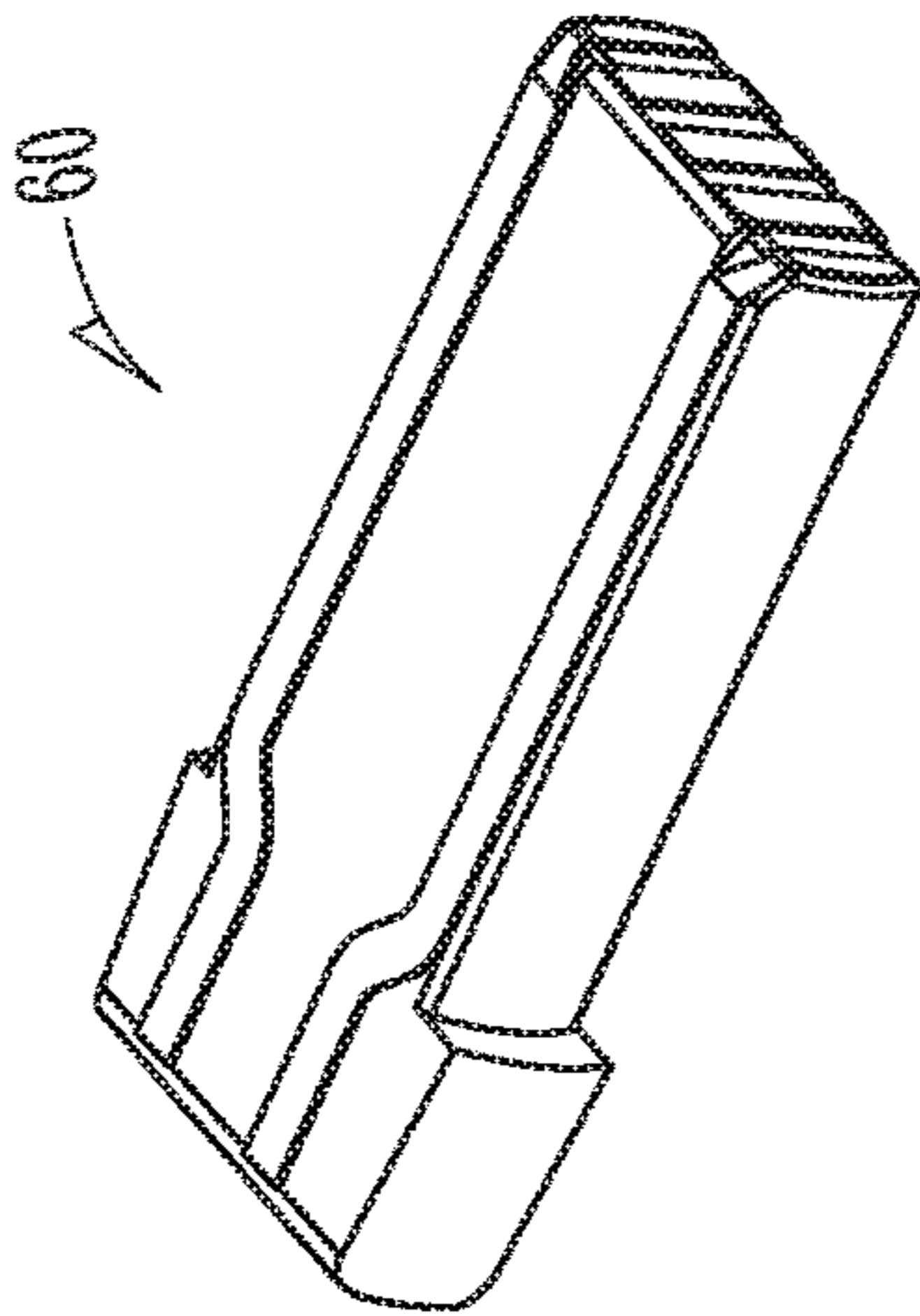

Fig. 6H

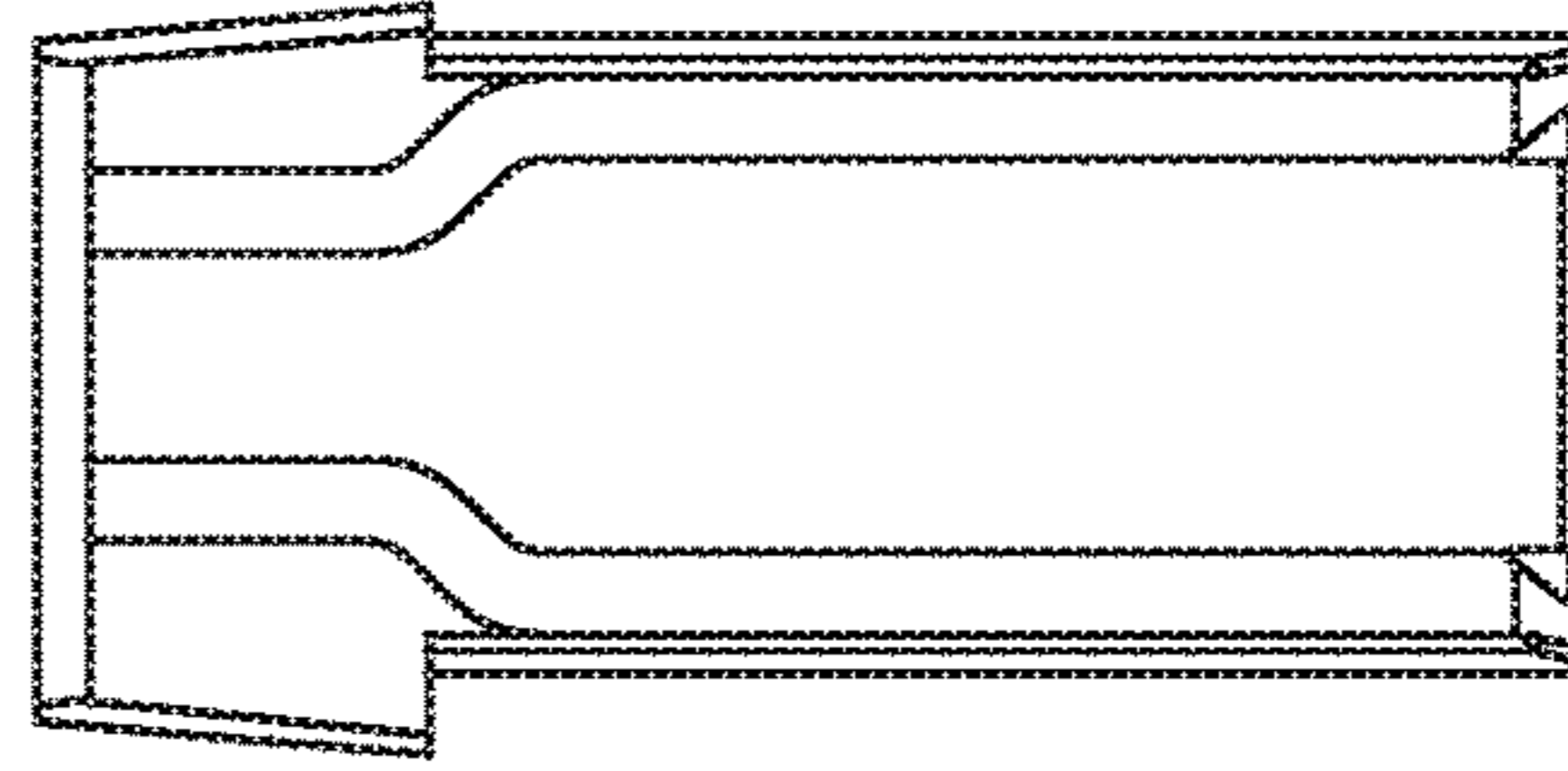

Fig. 6K

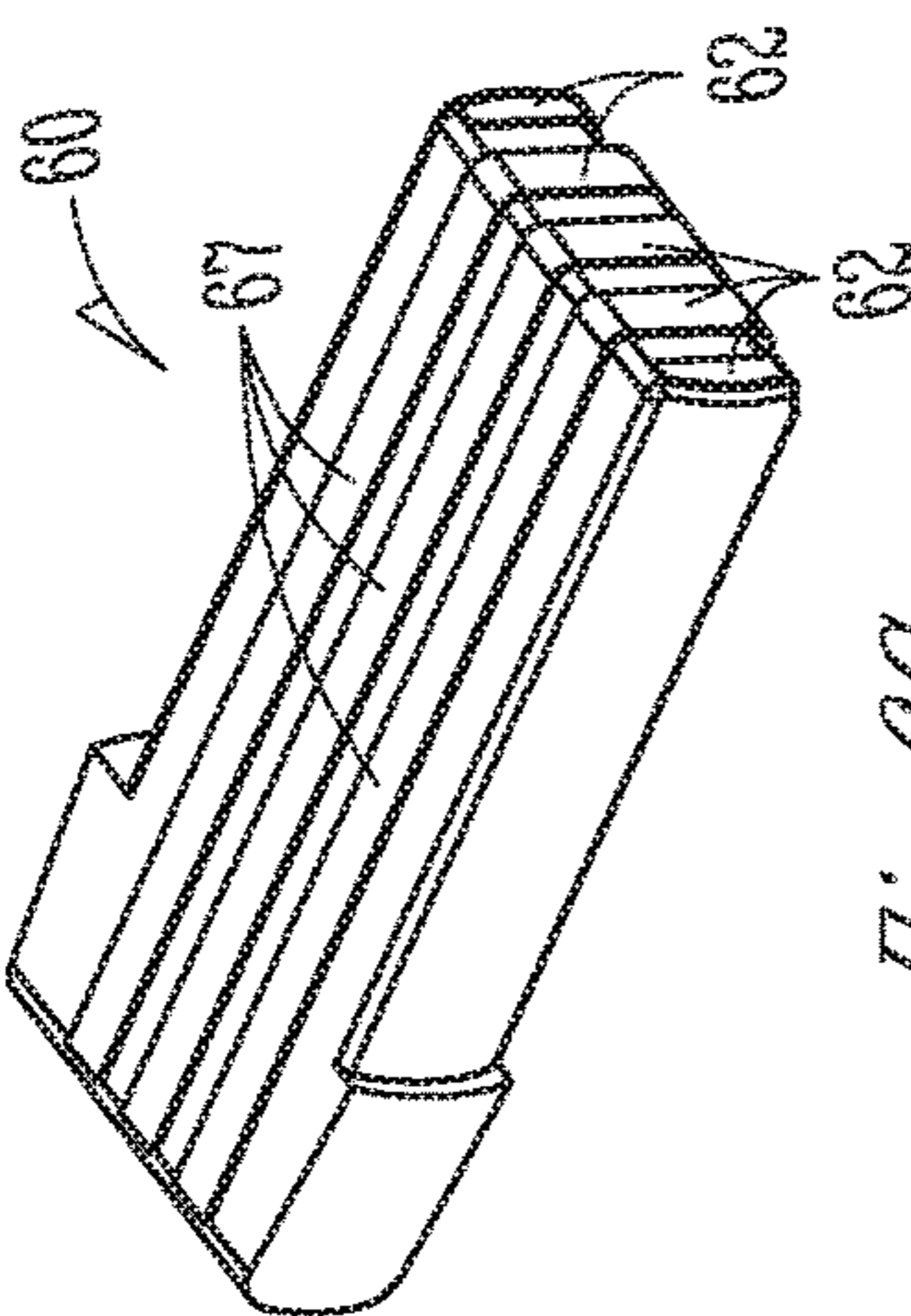

Fig. 6G

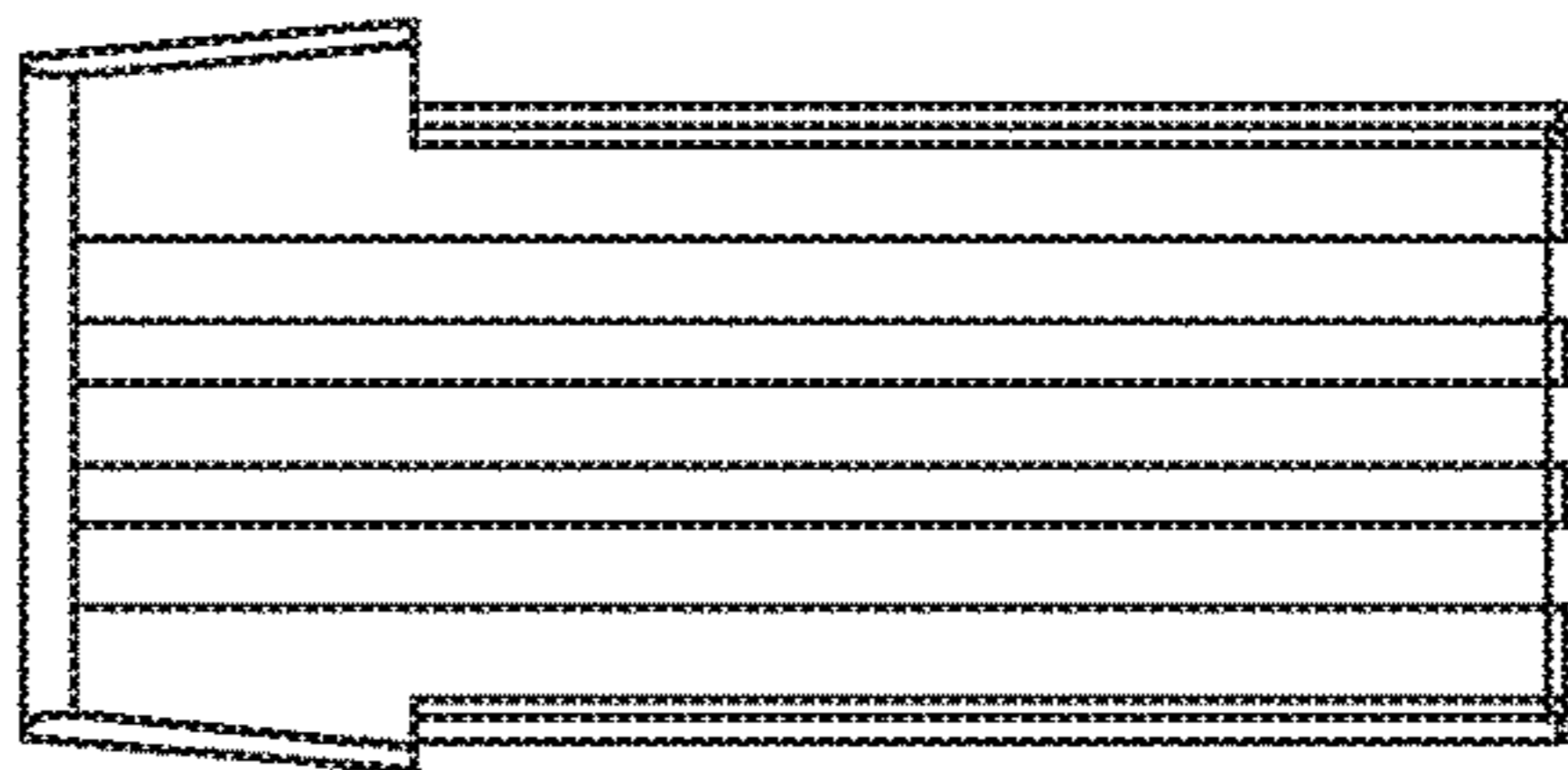

Fig. 6J

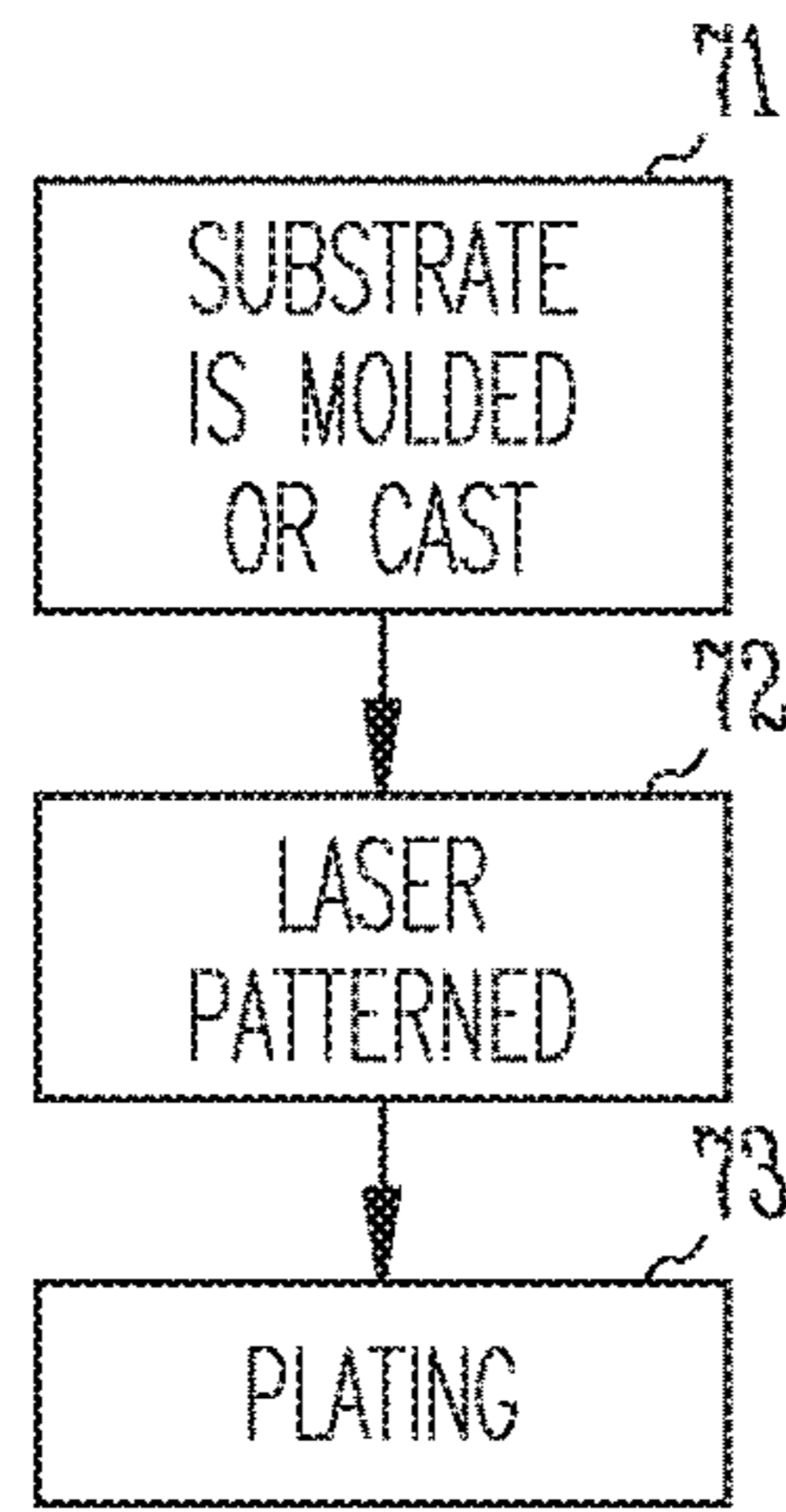

Fig. 7

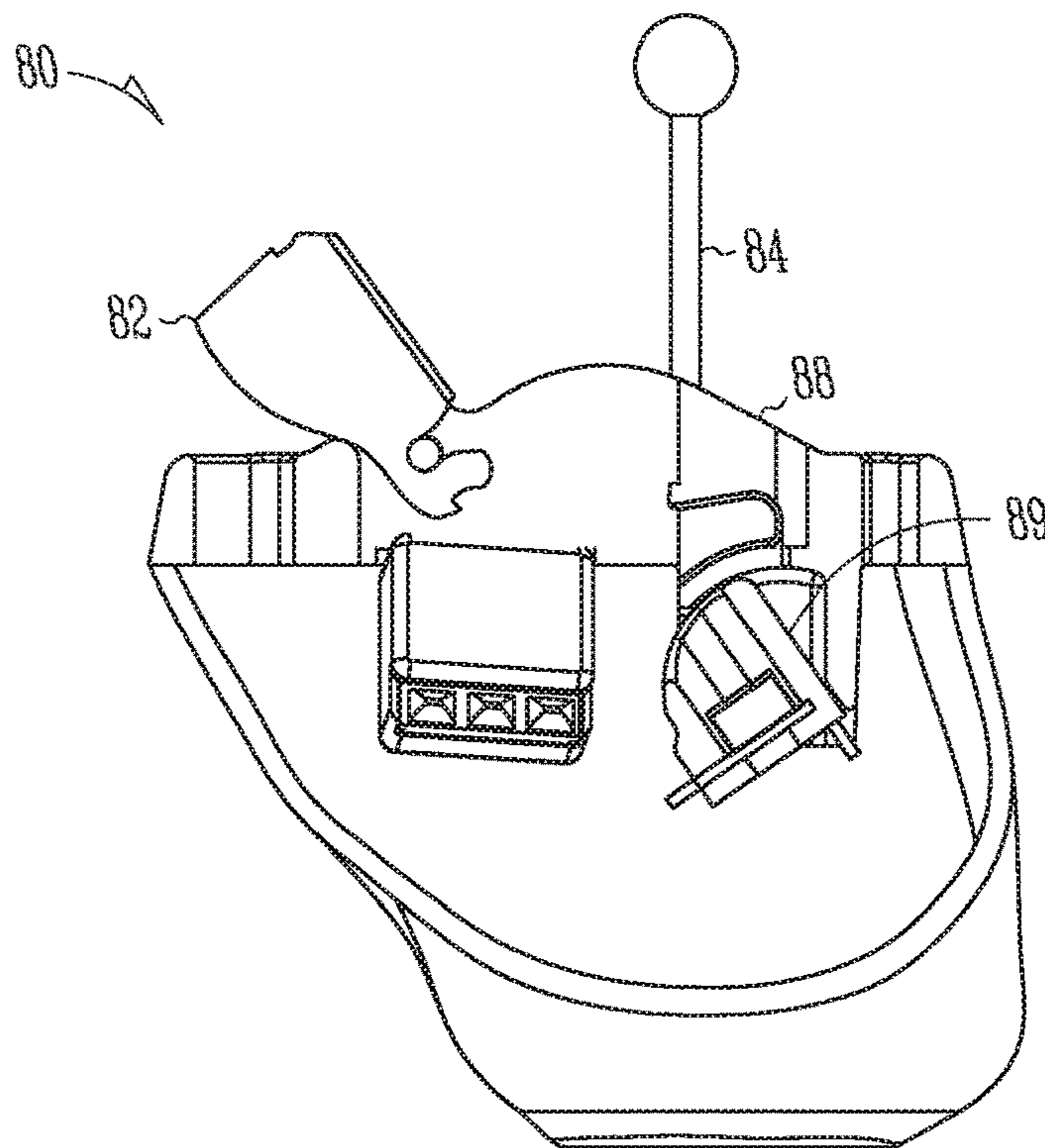

Fig. 8A

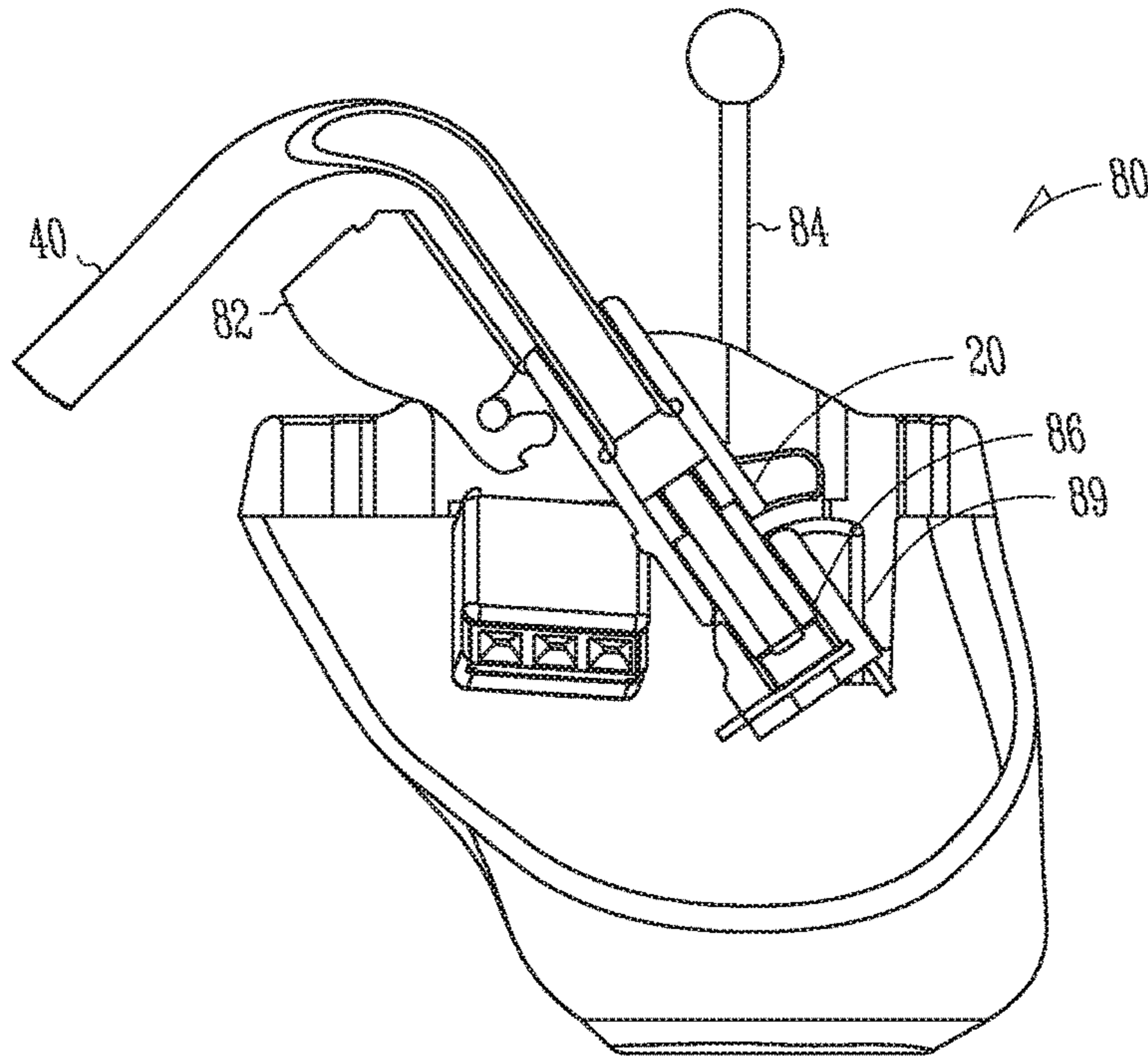

Fig. 8B

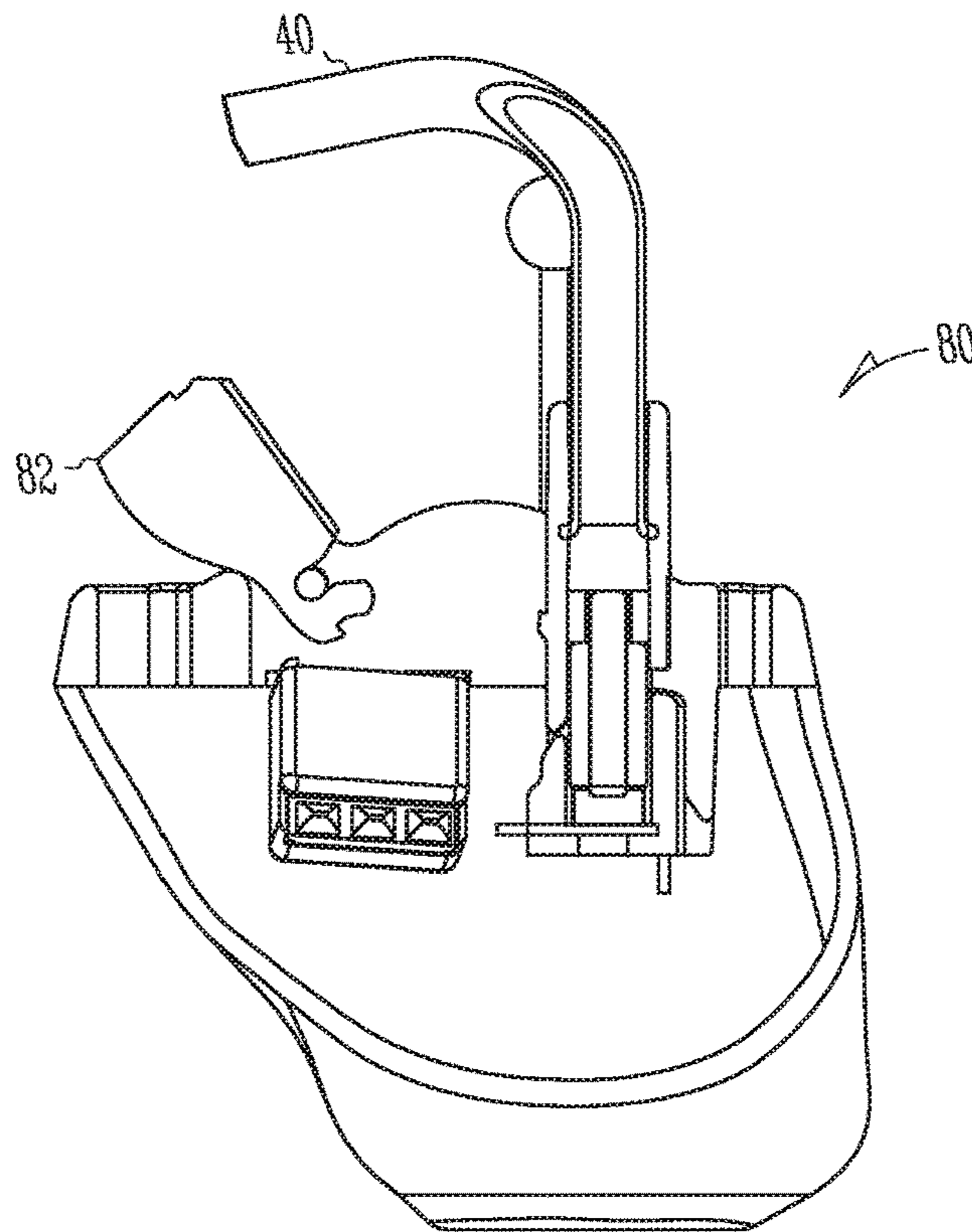

Fig. 8C

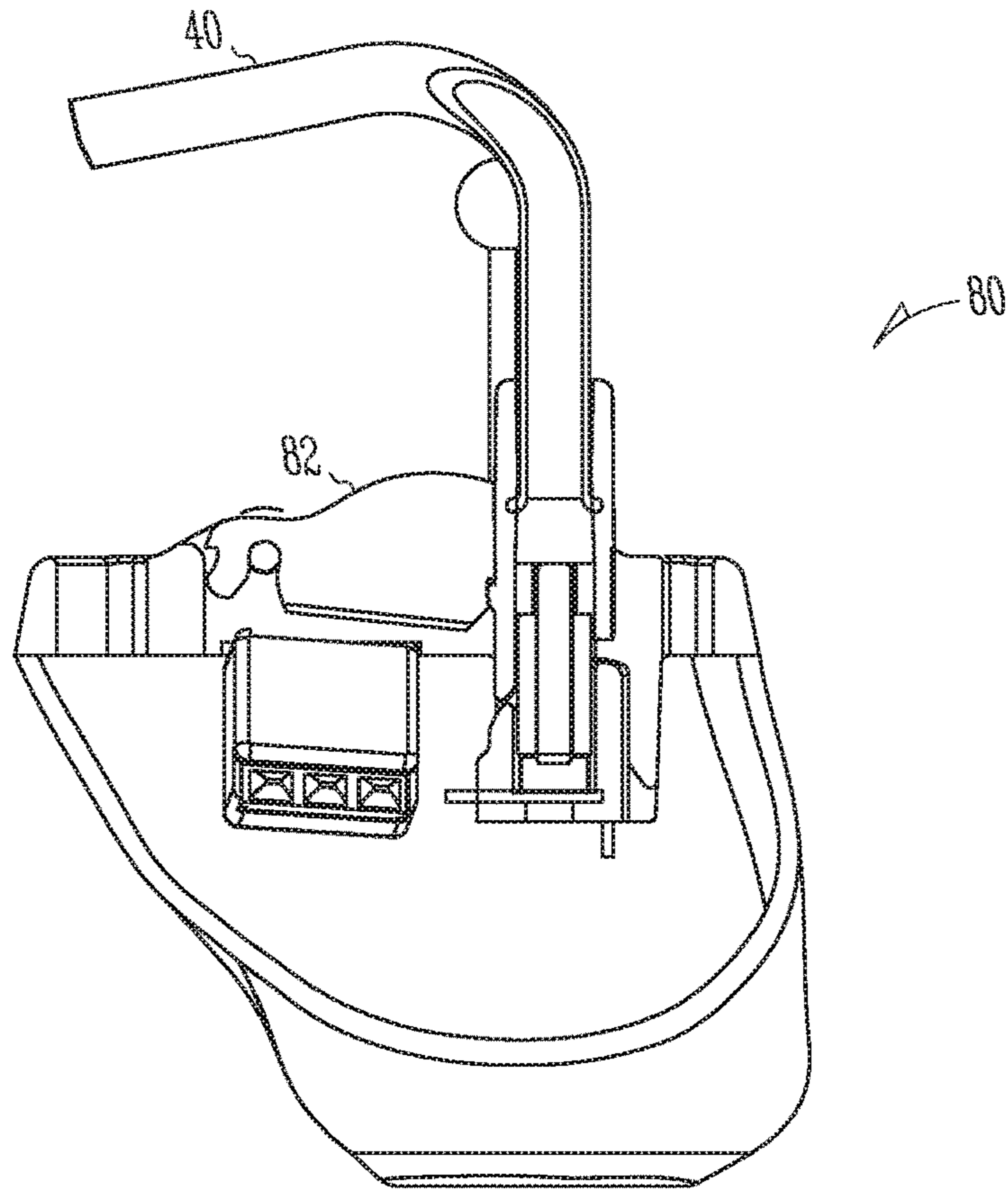

Fig. 8D

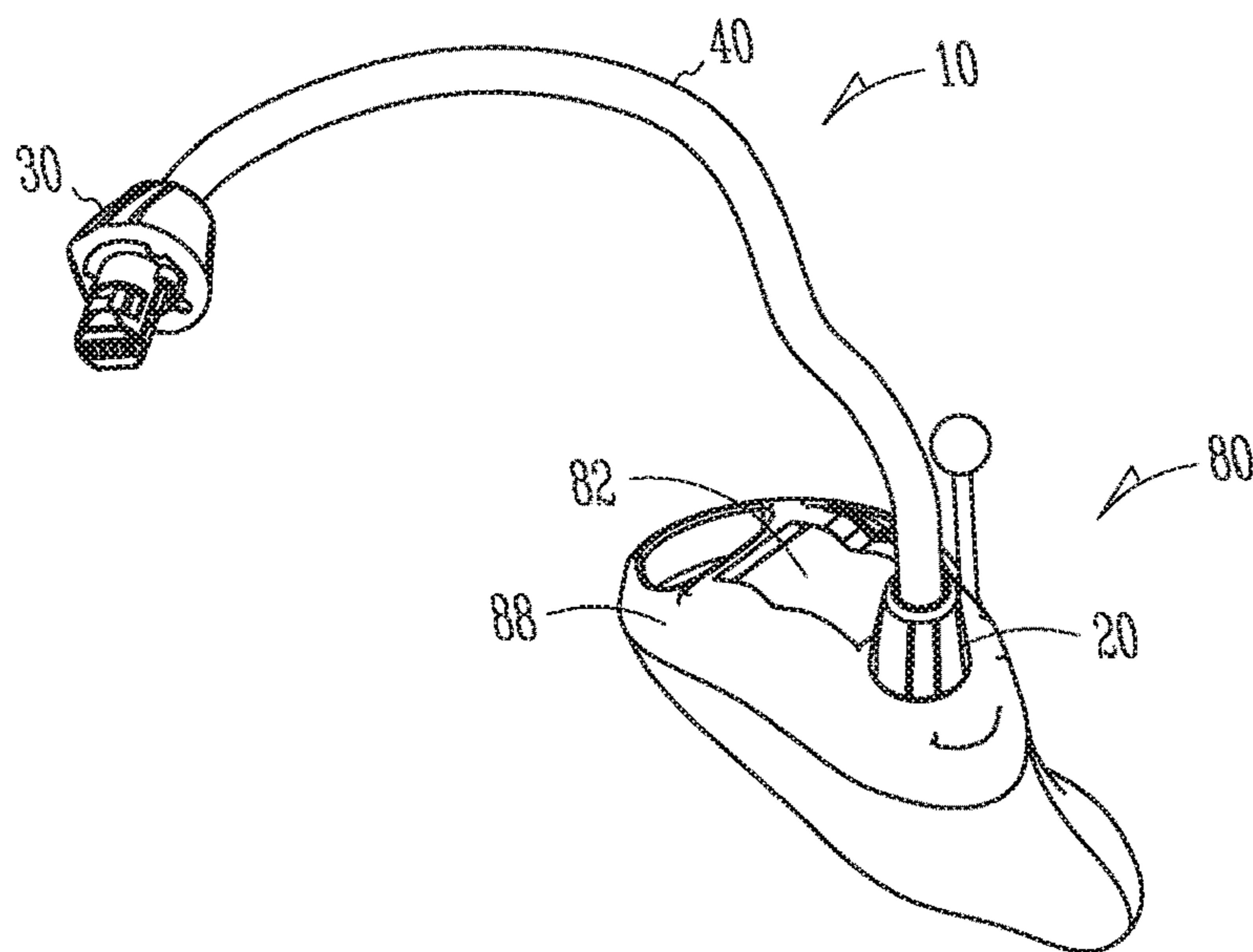

Fig. 8E

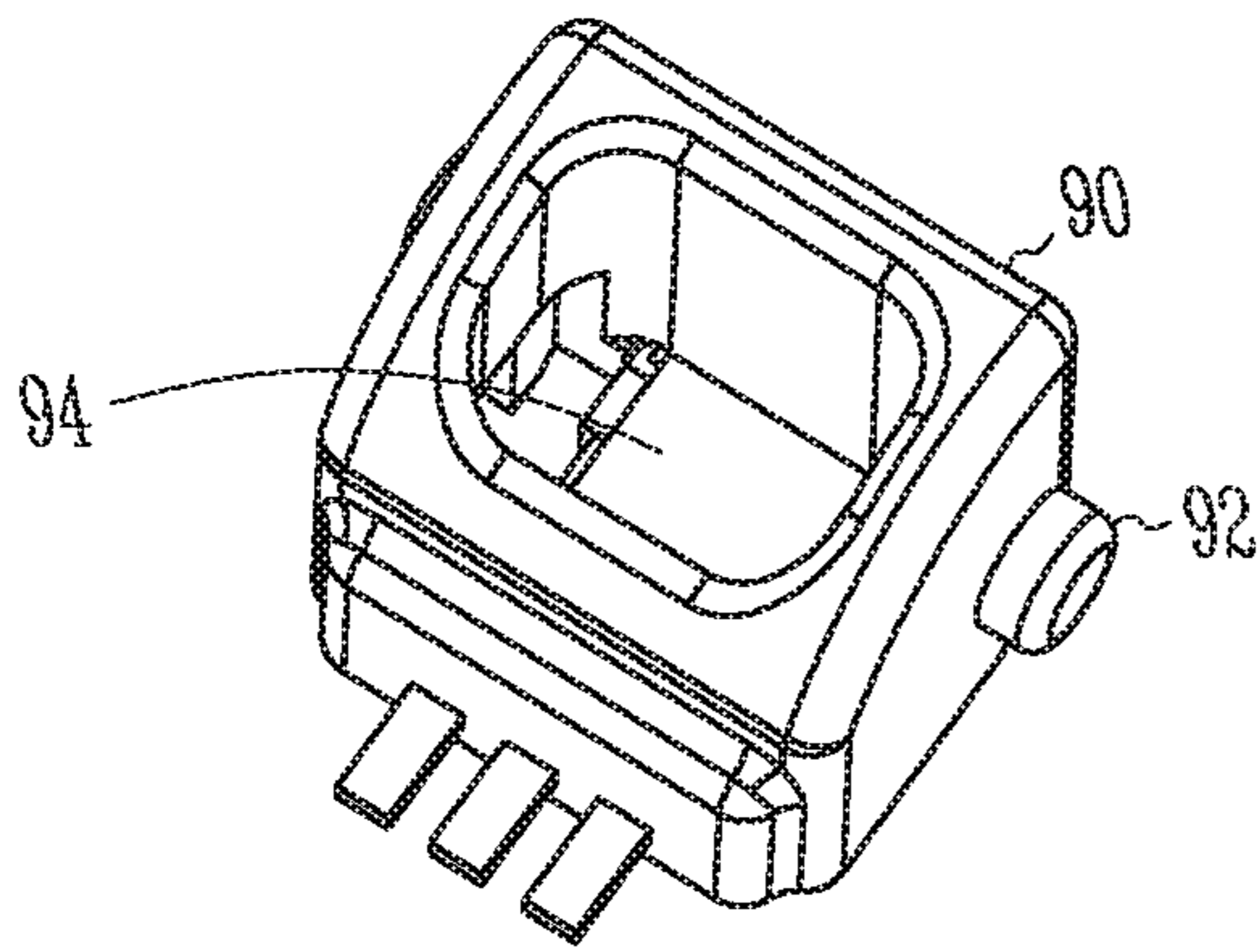

Fig. 9

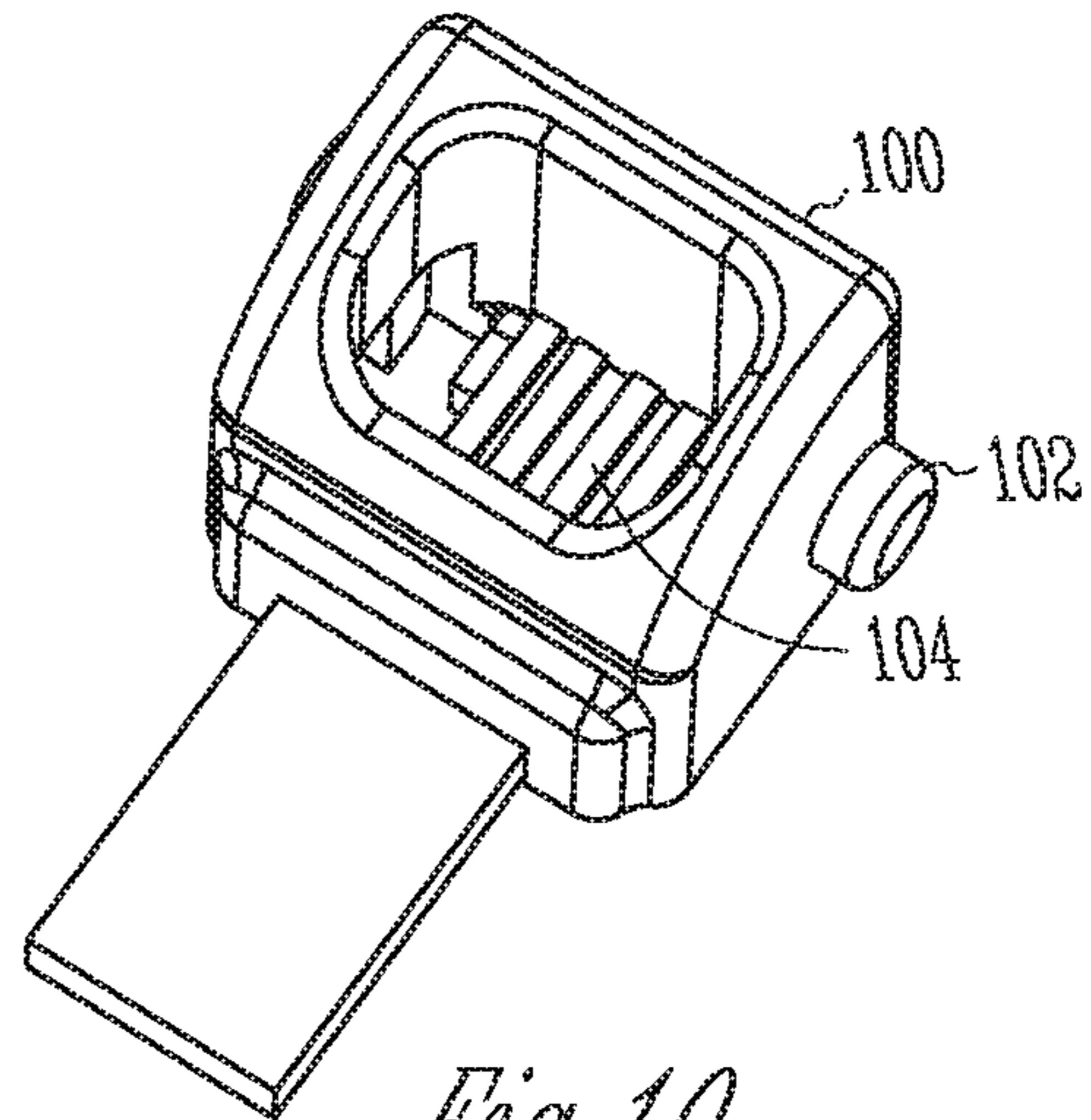

Fig. 10

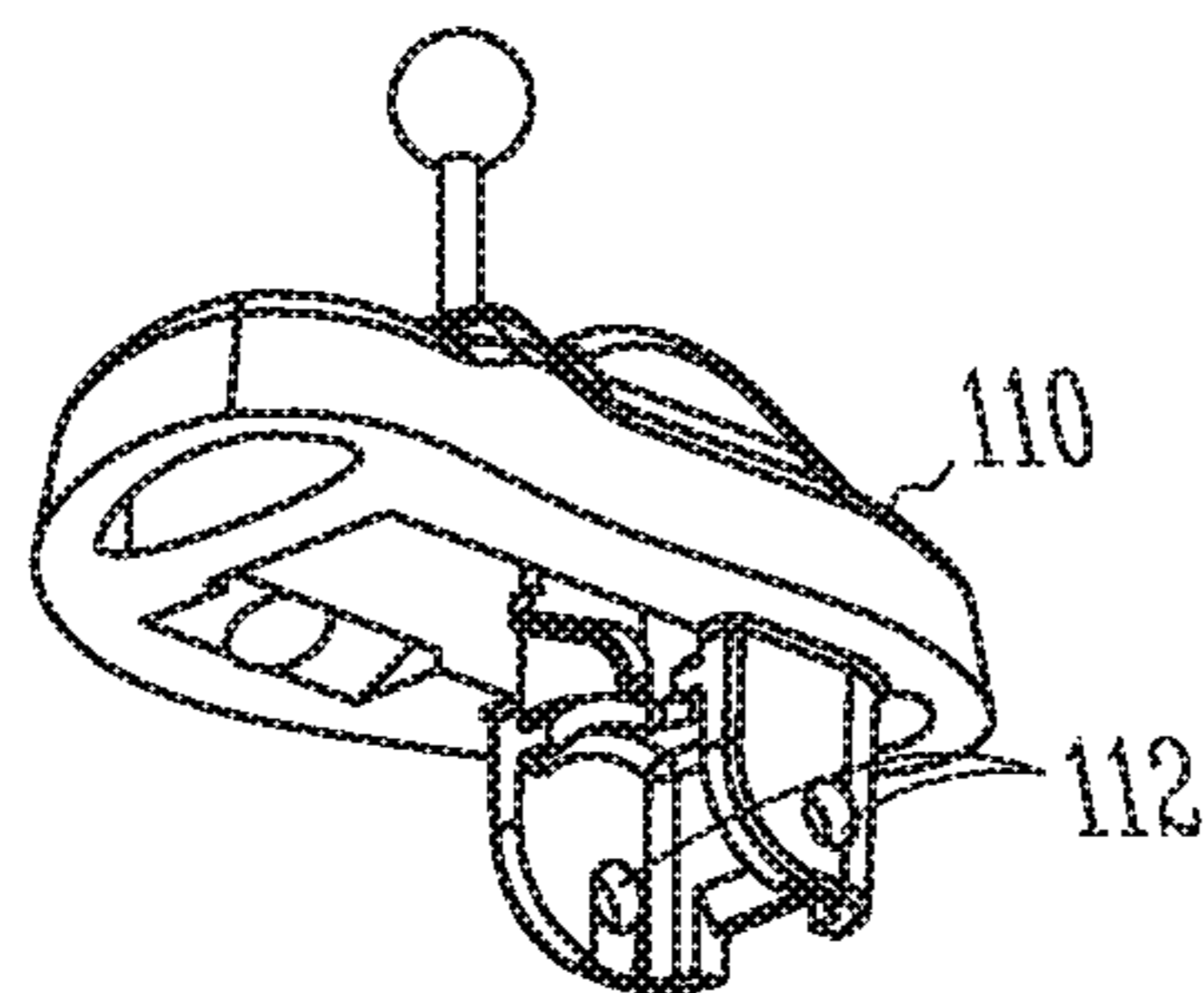

Fig. 11

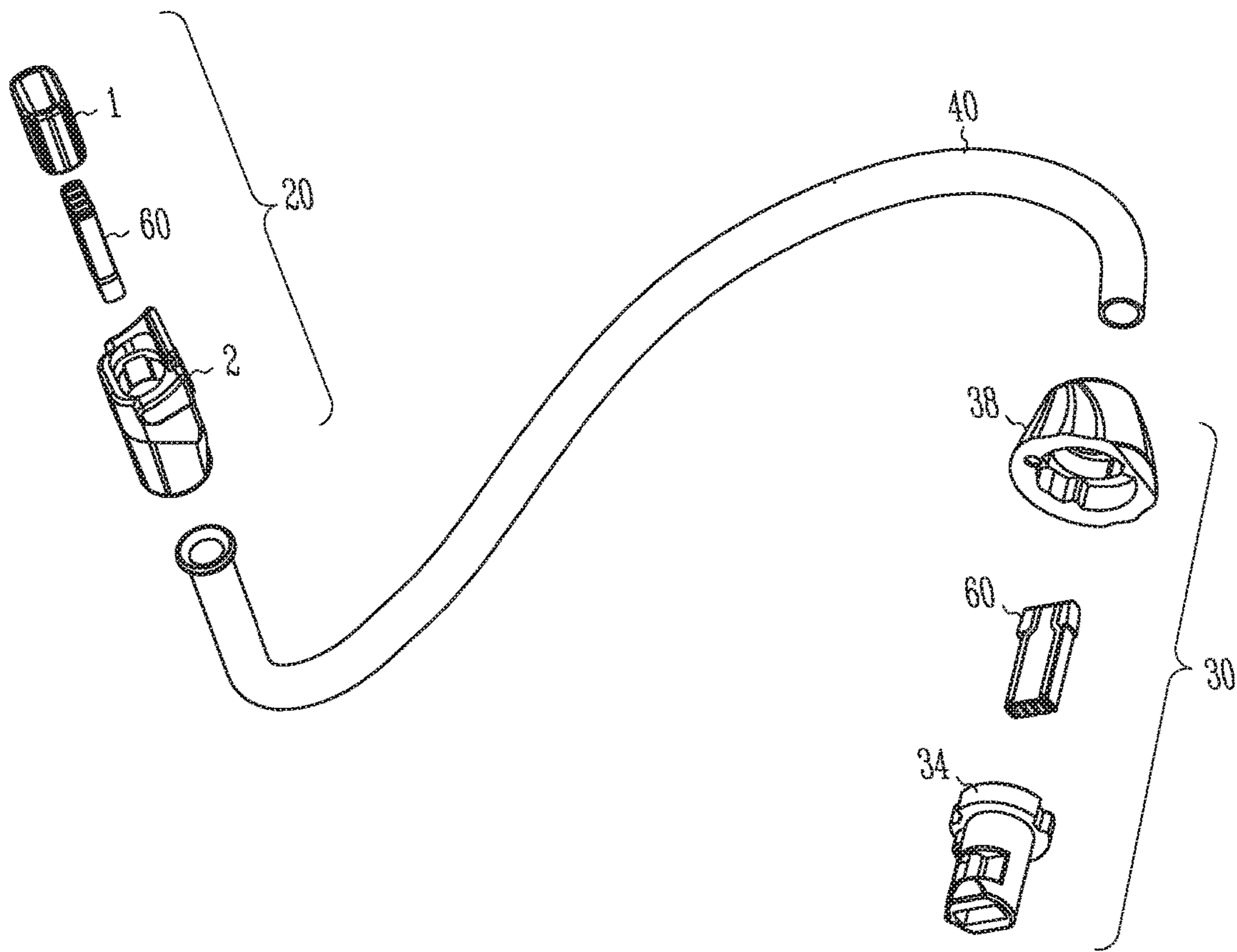

Fig. 12

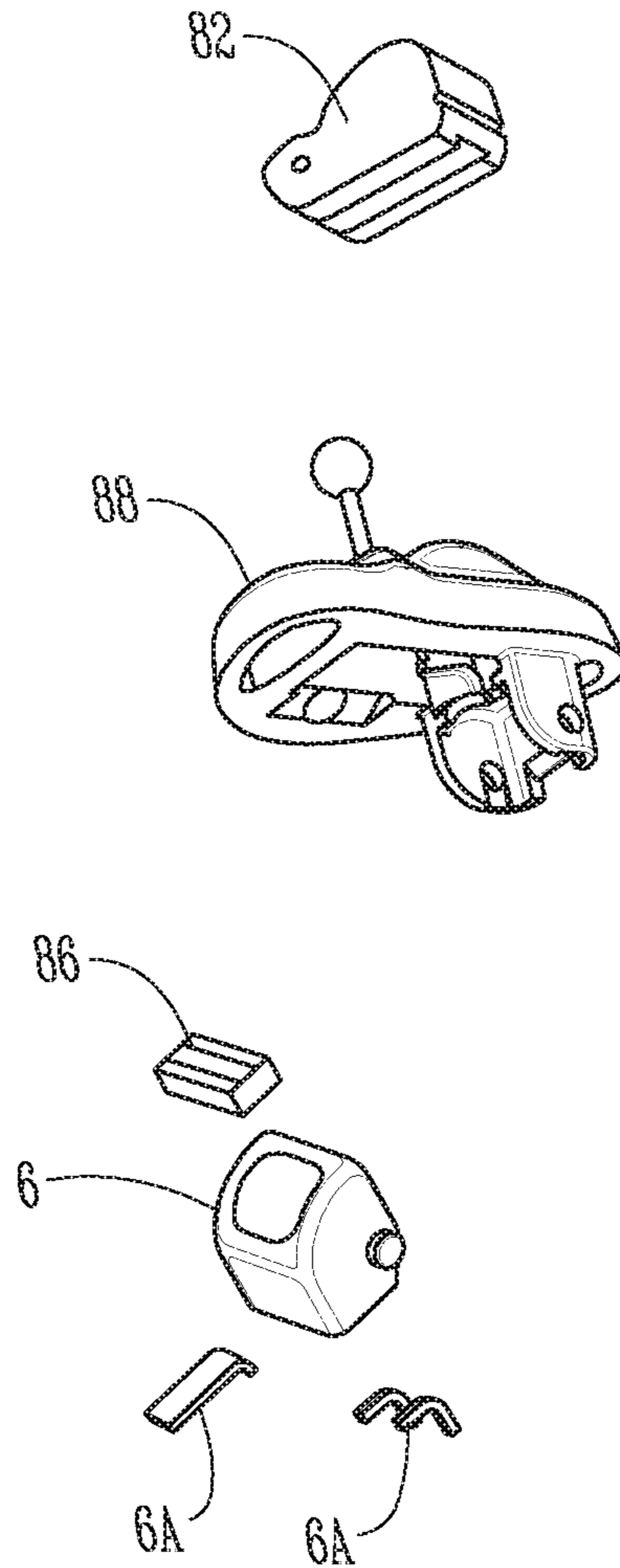

Fig. 13

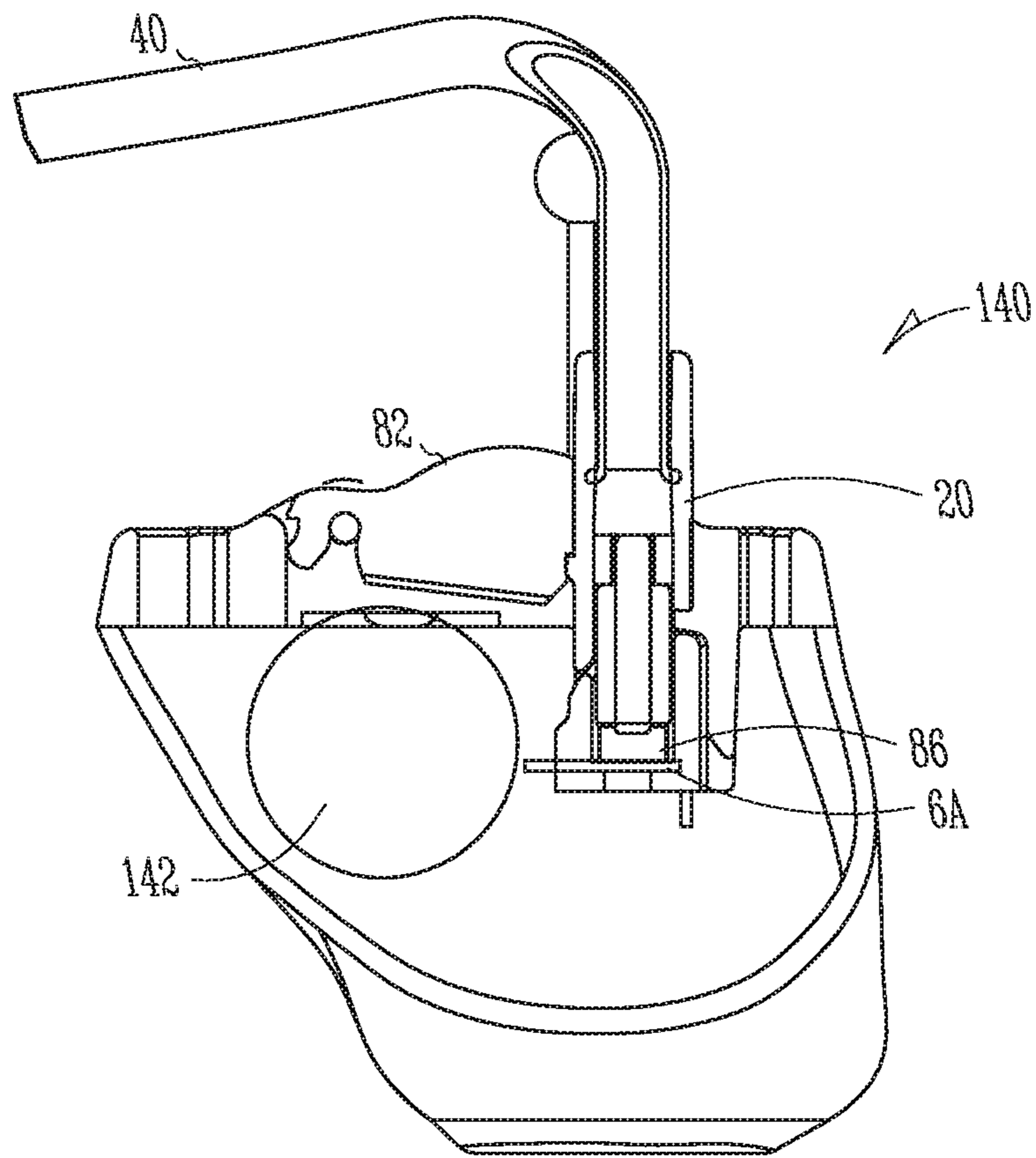

Fig. 14

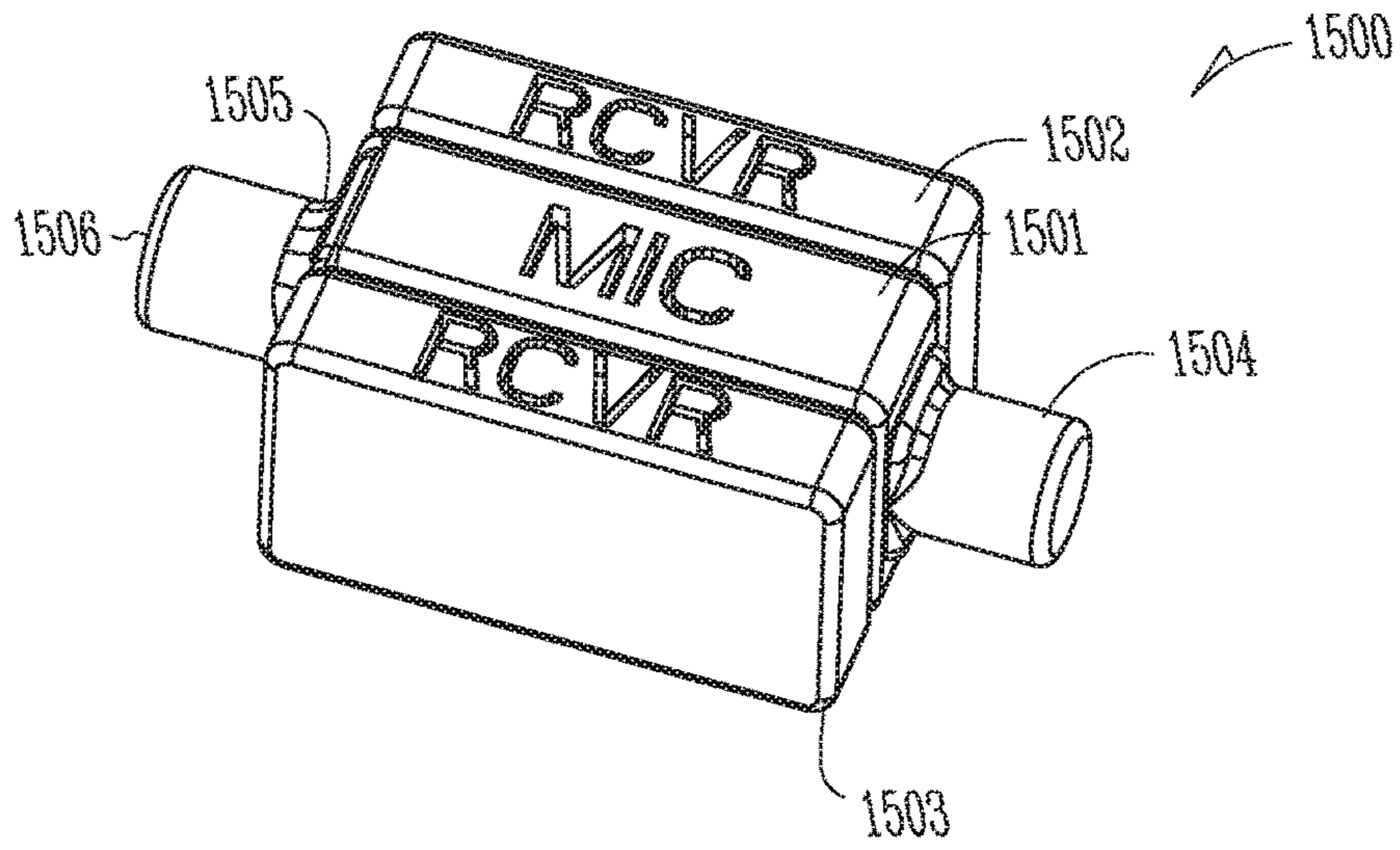

Fig. 15

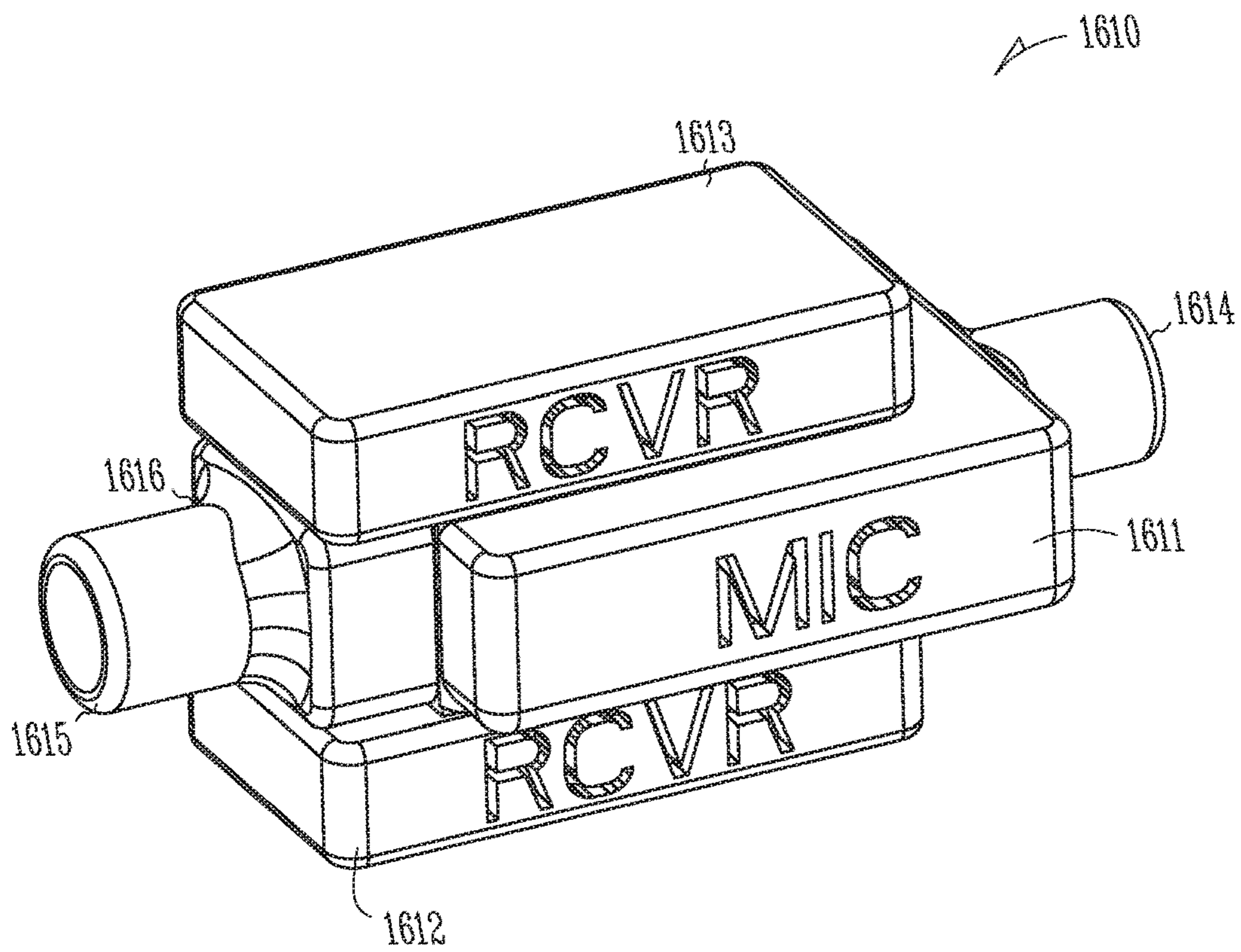

Fig. 16

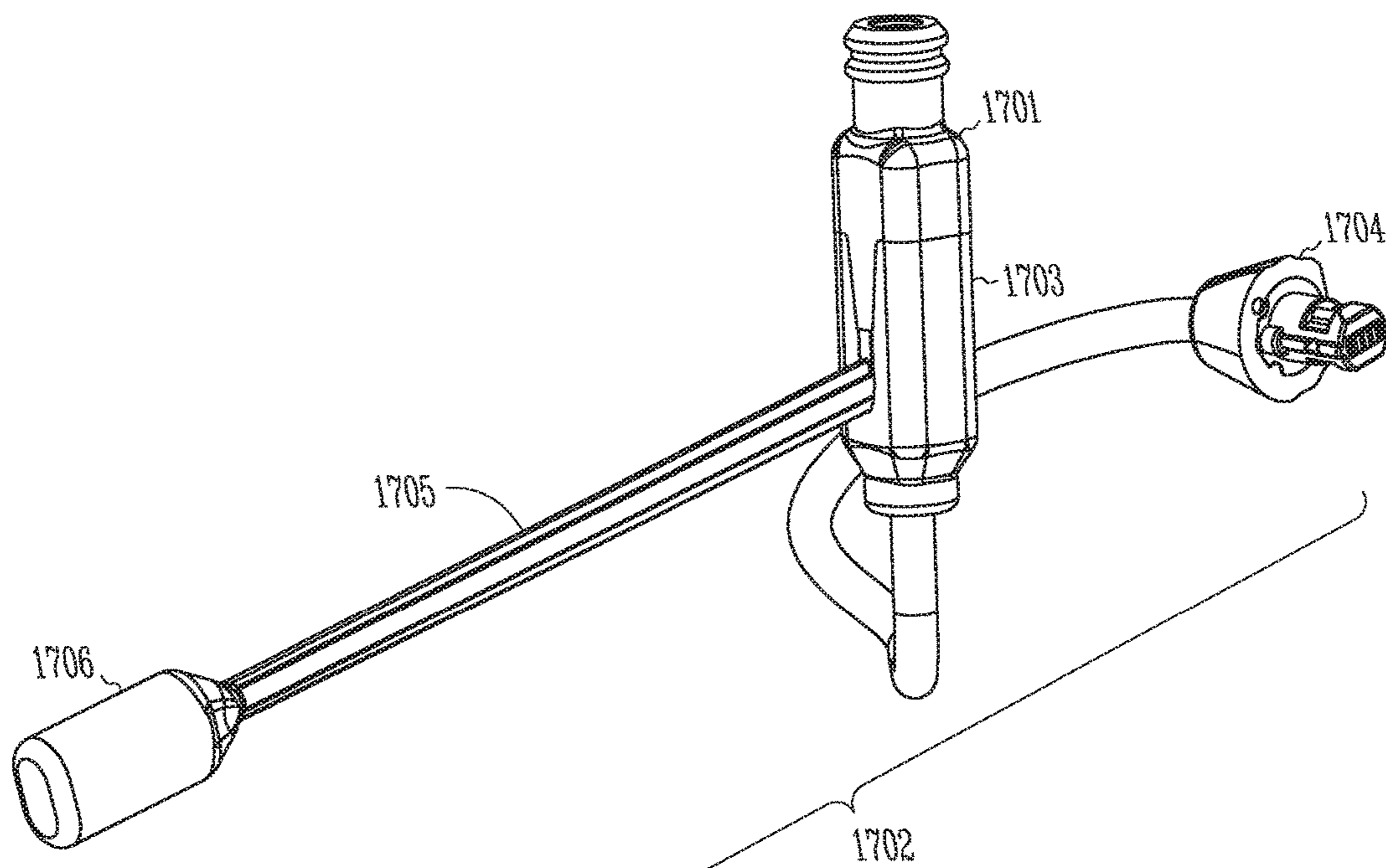

Fig. 17

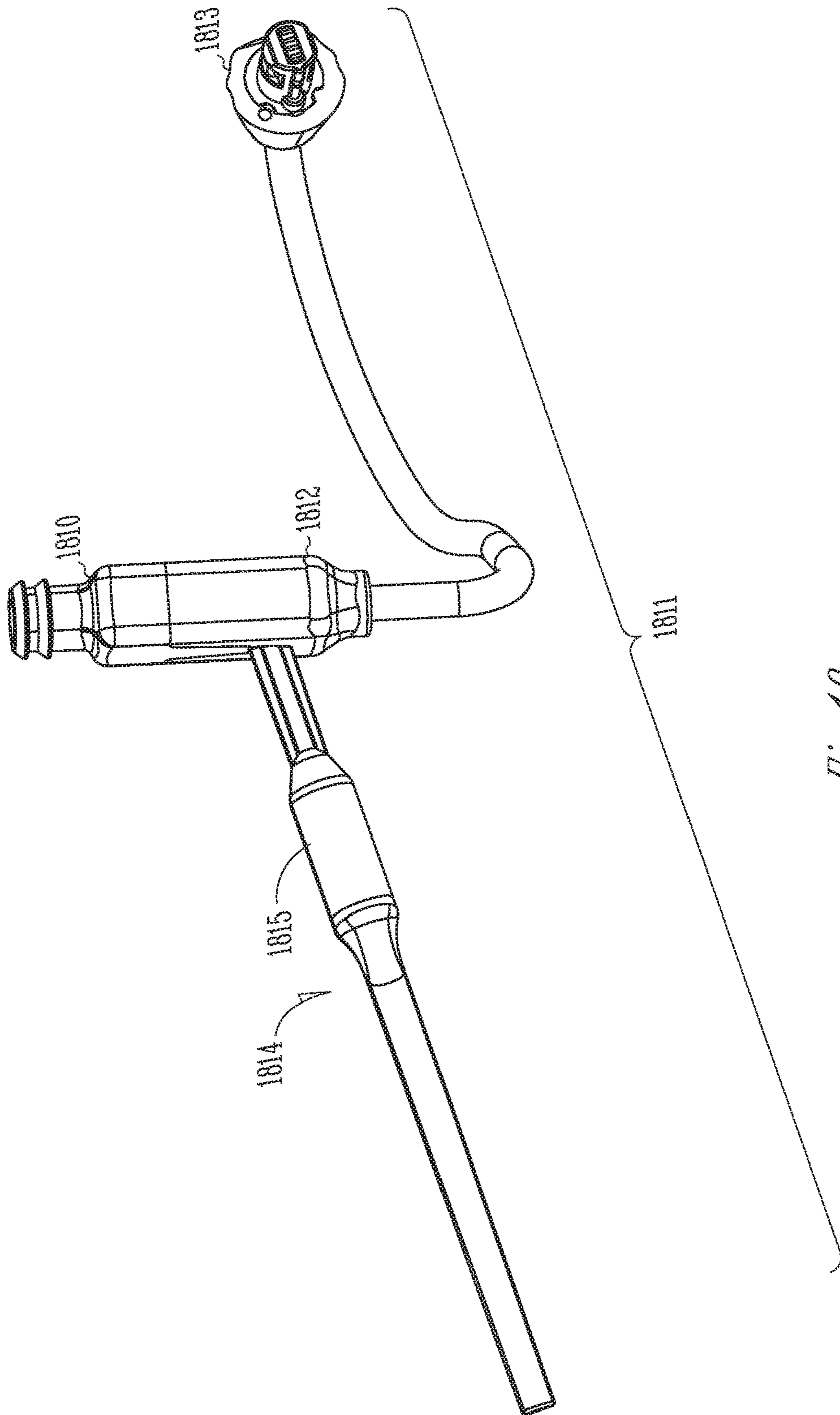

Fig. 18

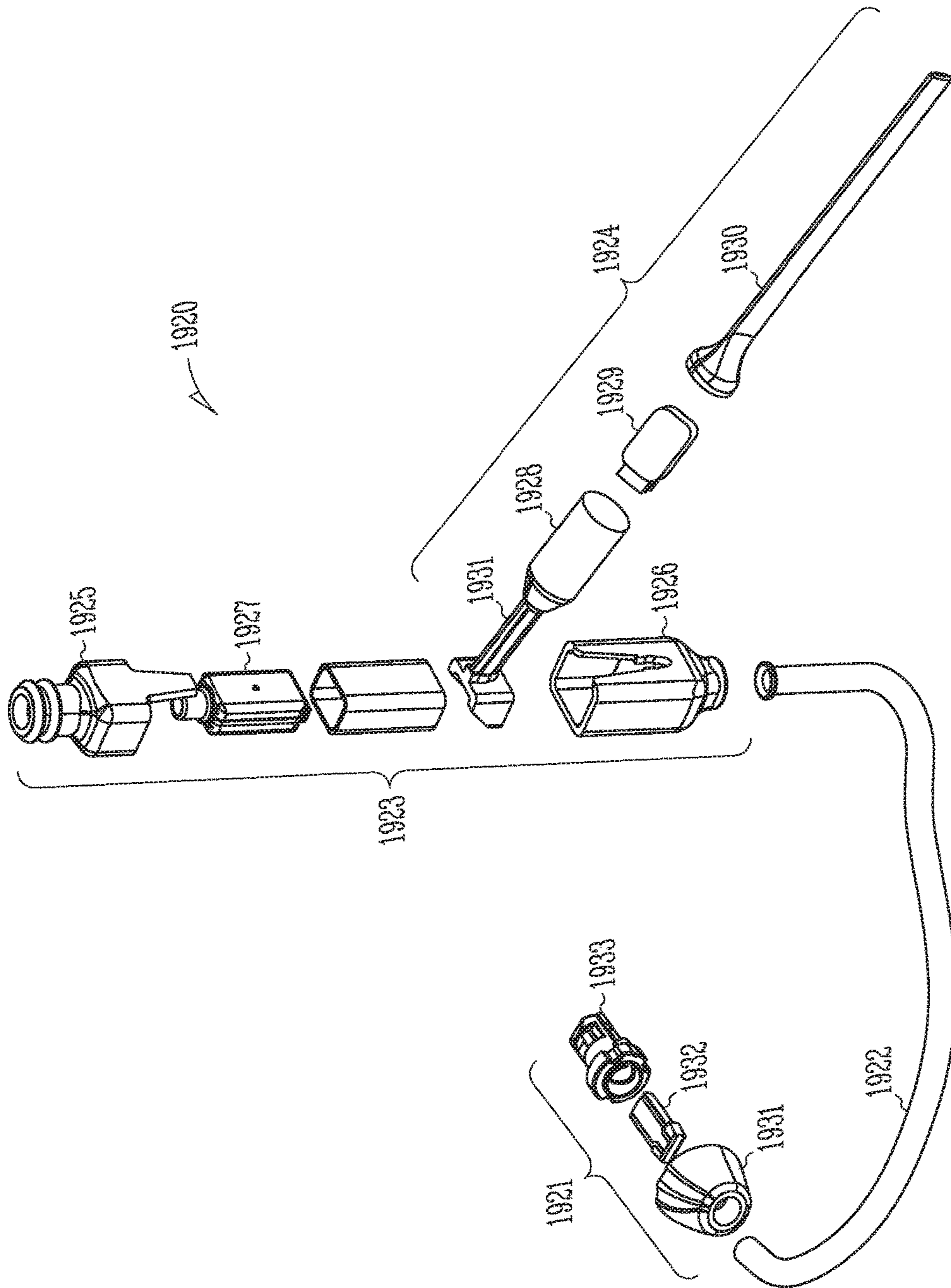

Fig. 19

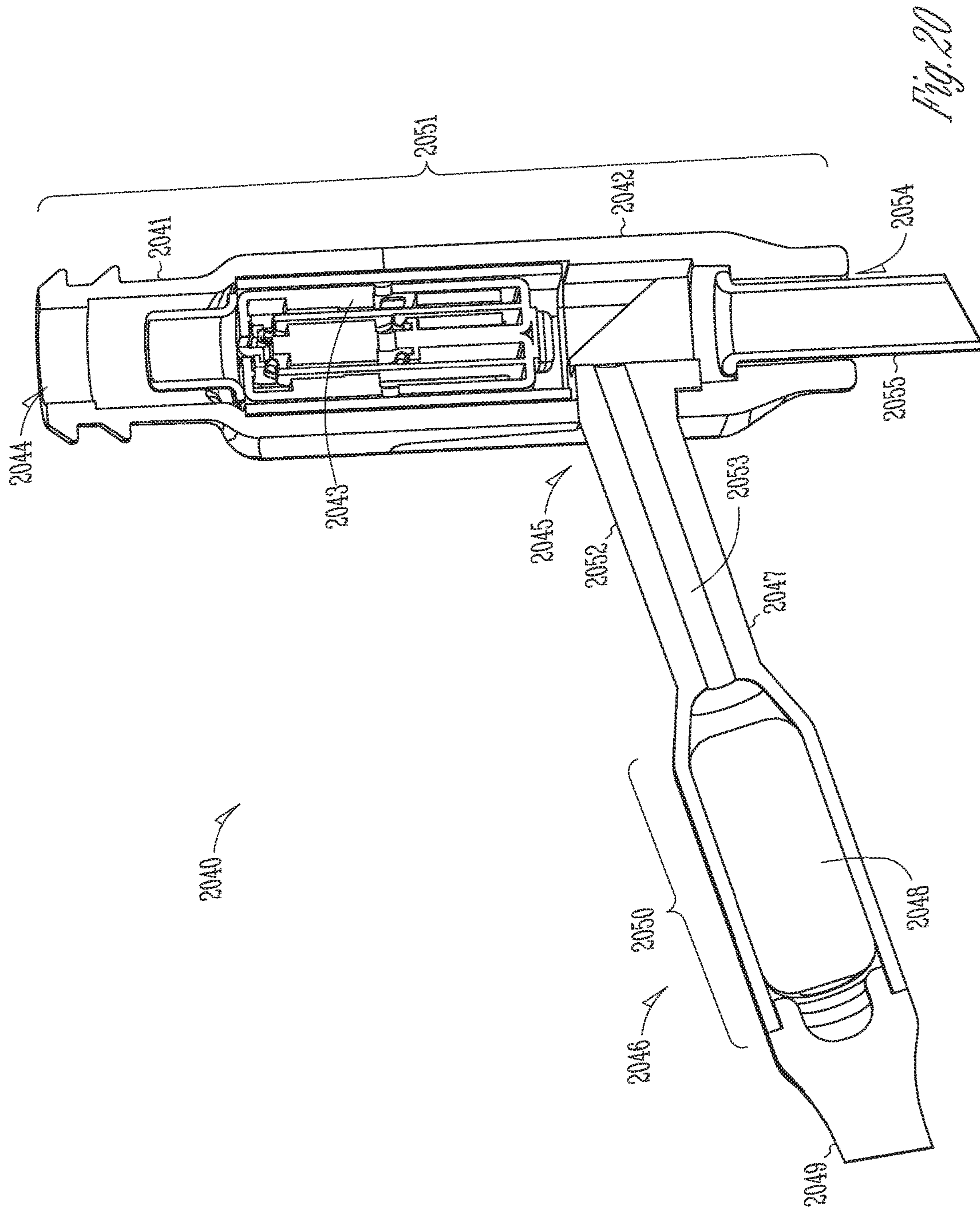

Fig. 20

MODULAR CONNECTION ASSEMBLY FOR A HEARING ASSISTANCE DEVICE

CLAIM OF PRIORITY

This application is a continuation of U.S. patent application Ser. No. 14/301,103, filed Jun. 10, 2014, now issued as U.S. Pat. No. 9,693,154, which is a continuation of U.S. patent application Ser. No. 12/548,051, filed Aug. 26, 2009, now issued as U.S. Pat. No. 8,781,141, which application claims the benefit under 35 U.S.C. 119(e) of U.S. Provisional Patent Application Ser. No. 61/092,336, filed Aug. 27, 2008, U.S. Provisional Patent Application Ser. No. 61/138,066, filed Dec. 16, 2008, and U.S. Provisional Patent Application Ser. No. 61/142,125, filed Dec. 31, 2008, which applications are incorporated herein by reference in their entirety.

FIELD OF THE INVENTION

The present subject matter relates to hearing assistance devices and in particular to connections for hearing assistance devices.

BACKGROUND

Hearing assistance devices can feature speakers, also known as receivers, in or about the ear canal of a wearer. One type of hearing assistance device includes hearing aids. A hearing aid with a speaker (receiver) that is connected with wires to an electronics unit is called a receiver-in-the-ear (RITE) or receiver-in-the-canal (RIC) type hearing aid. The wires of RIC and RITE type hearing aids are typically disposed in a tubing or jacket which is intended to be inconspicuous and reliable. The introduction of small wires in designs such as RIC and RITE type hearing aids create issues of reliability and ease of manufacture and use. Small wires can be difficult to connect and such connections are susceptible to deterioration or breakage from prolonged use. Components will wear out with use and may lose performance or fail to function. Additional problems arise when wires connected to a remote receiver, such as electromagnetic interference issues.

Thus, there is a need in the art for improved connections for hearing assistance devices. The connections should be reliable, easy to manufacture, and easy to use.

SUMMARY

The present subject matter relates to an improved connection assembly for hearing assistance devices. The improved connection assembly provides a connection system that is reliable, straightforward to manufacture, and easy to use. The present connection assembly provides a rapid replacement option for the cable and/or the receiver or other electronics connected to the cable. The present subject matter provides for a connection assembly that can be extended to provide connections for a variety of applications which are not limited to a speaker (receiver) in the ear. In various applications, improvements are provided for telecoil functionality. Other sensors and new configurations of component placement are supported using the present assembly, including, but not limited to GMR and TMR sensors. New configurations of electronics for e are supported. The present subject matter also addresses in various applications issues, such as water resistance, water proofing, and tamper resistance/proofing. Various electromagnetic interference issues

are addressed. In some examples a shielded set of wires are included. In some examples a twisted pair of wires is included. Various combinations of wires for different applications are supported with the present connector system.

This Summary is an overview of some of the teachings of the present application and not intended to be an exclusive or exhaustive treatment of the present subject matter. Further details about the present subject matter are found in the detailed description and appended claims. The scope of the present invention is defined by the appended claims and their legal equivalents.

BRIEF DESCRIPTION OF THE DRAWINGS

FIG. 1 shows a modular connection assembly for a hearing assistance device having a first connector and a second connector, according to one embodiment of the present subject matter.

FIG. 2 shows an enlarged view of the second connector of the modular connection assembly of FIG. 1, according to one embodiment of the present subject matter.

FIG. 3 shows an exploded view of the second connector of the modular connection assembly of FIG. 1, according to one embodiment of the present subject matter.

FIG. 4 shows an exploded view of the second connector of the modular connection assembly of FIG. 1, according to one embodiment of the present subject matter.

FIG. 5 shows a wiring configuration of the cable of the modular connection assembly of FIG. 1, according to one embodiment of the present subject matter.

FIG. 6A shows a top view of an injection molded circuit connector (IMC connector), according to one embodiment of the present subject matter.

FIG. 6B shows a bottom view of the IMC connector of FIG. 6A, according to one embodiment of the present subject matter.

FIG. 6C shows a side view of the IMC connector of FIG. 6A, according to one embodiment of the present subject matter.

FIG. 6D shows a top view of traces of the IMC connector of FIG. 6A, according to one embodiment of the present subject matter.

FIG. 6E shows a bottom view of traces of the IMC connector of FIG. 6A, according to one embodiment of the present subject matter.

FIG. 6F shows an end view of traces of the IMC connector of FIG. 6A, according to one embodiment of the present subject matter.

FIGS. 6G-6L show various views of an IMC connector according to one embodiment of the present subject matter.

FIG. 7 shows a process for construction of an IMC connector, according to one embodiment of the present subject matter.

FIGS. 8A-8E demonstrate a process for connecting a device having a faceplate to the second connector of the modular connection assembly, according to one embodiment of the present subject matter.

FIG. 9 demonstrates one example of how contacts are disposed in a receptacle, according to one embodiment of the present subject matter.

FIG. 10 demonstrates one example of how contacts are disposed in a receptacle, according to one embodiment of the present subject matter.

FIG. 11 demonstrates a "hanging basket" faceplate design, according to one embodiment of the present subject matter.

FIG. 12 shows an exploded view of the modular connection assembly, according to one embodiment of the present subject matter.

FIG. 13 shows an exploded view of a faceplate with receptacle in a "hanging basket" configuration, according to one embodiment of the present subject matter.

FIG. 14 demonstrates one use of the modular connection assembly with active components, according to one embodiment of the present subject matter.

FIG. 15 shows a microphone and receiver assembly, according to one embodiment of the present subject matter.

FIG. 16 shows a microphone receiver assembly with the microphone offset between the two receivers, according to one embodiment of the present subject matter.

FIG. 17 shows a modular connection assembly with an integrated telecoil, according to one embodiment of the present subject matter.

FIG. 18 shows a modular connection assembly with an integrated telecoil, according to one embodiment of the present subject matter.

FIG. 19 shows an exploded view of a modular connection assembly for a receiver with an integrated telecoil, according to one embodiment of the present subject matter.

FIG. 20 shows a cross-section view of a portion of an assembled modular connection assembly, according to one embodiment of the present subject matter.

DETAILED DESCRIPTION

The following detailed description of the present invention refers to subject matter in the accompanying drawings which show, by way of illustration, specific aspects and embodiments in which the present subject matter may be practiced. These embodiments are described in sufficient detail to enable those skilled in the art to practice the present subject matter. References to "an", "one", or "various" embodiments in this disclosure are not necessarily to the same embodiment, and such references contemplate more than one embodiment. The following detailed description is, therefore, not to be taken in a limiting sense, and the scope is defined only by the appended claims, along with the full scope of legal equivalents to which such claims are entitled.

FIG. 1 shows a modular connection assembly for a hearing assistance device having a first connector and a second connector, according to one embodiment of the present subject matter. Modular connection assembly 10 includes a first connector 20 and a second connector 30. The first connector 20 includes a plurality of contacts 22 connected to a plurality of contacts 32 of the second connector 30 using a plurality of wires in cable 40. The modular connection assembly 10 of FIG. 1 demonstrates five (5) contacts per connector, but it is understood that other numbers of contacts may be used without departing from the scope of the present subject matter. The modular connection assembly 10 can be used in a variety of applications, including, but not limited to, hearing aids featuring electronics connected to the first connector and electronics connected to the second connector. In various embodiments, the electronics connected to the first connector 20 include, but are not limited to one or more of a receiver, a microphone, a telecoil, a sensor, or combinations thereof. In various embodiments, the electronics connected to the second connector 30 include, but are not limited to, a behind-the-ear type device, a receiver-in-the-canal type device, a receiver-in-the-ear type device, and an over the ear type of device.

Various wires can be used in cable 40, including, but not limited to, stranded Litz wires. In various embodiments, the wires in cable 40 are flexible. In various embodiments, the wires in cable 40 are enclosed in tubing. The tubing can be made of any flexible material, including, but not limited to PEBAX. Reinforced tubing, such as reinforced PEBAX may be used. With reinforcement, improvements in flex modulus of about five (5) times may be achieved and improvements of about ten (10) times the tensile and elongation strength of wall sections may be achieved. Other amounts of reinforcement improvement can be achieved without departing from the scope of the present subject matter.

The connectors 22 and 32 can include a variety of conductors, and can be adapted to connect to a variety of receptacles. In various embodiments, constant contact is ensured by an elastomeric component having conductive and nonconductive portions which is placed under compression when the connector is seated in the receptacle. One such connection approach includes the use of conductive silicone in making the connections. In one approach, for example, a conductive silicone pad is placed in the receptacle and oriented so that its conductive and insulative regions are in alignment with a series of conductors on the connector and in the receptacle. Such designs include, but are not limited to, the approaches set forth in U.S. patent application Ser. No. 12/027,173 entitled: "Electrical Contacts Using Conductive Silicone in Hearing Assistance Devices" and Ser. No. 11/857,439 entitled: "System for Hearing Assistance Device Including Receiver in the Canal," the specifications of which are incorporated by reference in their entirety. One advantage of such connections is that they provide self-fitted interfaces. Another advantage is that if properly designed, such connections can be moisture resistant or moisture proof. Another advantage is that such connections reduce the need for very tight tolerance connections, which are difficult to produce and difficult to maintain. In one example application, a pad-to-pad variation of about 0.0002 inches (0.005 millimeters) is used. Other tolerances are possible, and this example is provided to illustrate a use of the present subject matter, but is not intended in an exclusive or exhaustive sense.

Connectors 20 and 30 may be color coded in various embodiments. Connectors 20 and 30 may be symmetrical in various embodiments. Connectors 20 and 30 may be asymmetrical in various embodiments. In various embodiments, connectors 20 and 30 include injection molded components. In various embodiments, connectors 20 and 30 include injection molded circuits. In various embodiments, connectors 20 and 30 are made using XYLEX; however, it is understood that other polymers can be used without departing from the scope of the present subject matter.

FIG. 2 shows an enlarged view of the second connector of the modular connection assembly of FIG. 1, according to one embodiment of the present subject matter. Contacts 32 at the end of the connector 30 are visible. These contacts are connected to wires in cable 40. Various strain reliefs are possible without departing from the scope of the present subject matter and these are shown to demonstrate possible uses of the present technology, but are not intended in a limiting or exhaustive sense.

FIG. 3 shows an exploded view of the second connector of the modular connection assembly of FIG. 1, according to one embodiment of the present subject matter. In this example, an injection molded circuit component 39 is employed ("IMC 39"). IMC 39 is depicted showing five (5) contacts 32 and five (5) points of contact 36 are shown to illustrate one IMC 39, but it is understood that other con-

5

nections are possible without departing from the scope of the present subject matter. For example, in some embodiments connection pads 36 are used to connect wires from the cable to contacts 32. Other numbers of contacts and connection pads and other types of components 39 with different configurations are possible without departing from the scope of the present subject matter. FIGS. 6A-6H demonstrate different views of two examples of types of components 39. In FIG. 3 one side of IMC 39 is shown with three connection pads 36, and FIG. 4 shows the other side with two connection pads 36. IMC 39 can be disposed within an insulative two part plug portion 34 and 38. One advantage of using polymers, such as XYLEX, is that various connector configurations can be made which allow for a good connection with a receptacle, both mechanically and electrically. The various connection pads 36 of IMC 39 are connected to wires in cable 40. These connections can be made by any type of connection method, including, but not limited to soldering. Such connections may be made by hand or using automation. The plug part 38 can be connected to tubing of cable 40 and act as a strain relief. The internal plug portion 34 includes a positive stop that allows the assembly of connector 30 with a receptacle. In embodiments using a flexible conductive interface, such as conductive silicone, the connector 30 is inserted into a receptacle until the stop is reached. This provides compression of the conductive silicone and a mechanical interface is provided which can be secured in position to provide reliable electrical contact and water resistance or water proofing. The stop allows the connector to provide a form fit each time it is used without overstressing the conductive silicone component. It also provides a consistent connection without variation issues incumbent in tight tolerance connectors.

FIG. 5 shows a wiring configuration of the cable of the modular connection assembly of FIG. 1, according to one embodiment of the present subject matter. In the example provided herein, five (5) wires are used to connect to the five point connector of FIG. 1; however, it is understood that a different number of wires and connections can be used without departing from the scope of the present subject matter. In the example provided herein, cable 40 includes a twisted pair 42 and a shielded wire bundle 44. Twisted pair 42 can be used for applications such as receiver connections where the twisting reduces conduction of certain types of electromagnetic interference. Shielded wire bundle 44 is useful for connections such as microphone connections. The shield is made of any conductive and flexible material, included, but not limited to, braided stainless steel. The shield assists in reducing crosstalk between connections of the microphone and receiver, in applications where a microphone and receiver are used. It is understood that different numbers of conductors may be employed and that other forms of electromagnetic shielding or management may be performed. In one embodiment, the shielding is connected to other electronics or to an equipotential surface. In one embodiment, the shielding is not connected to other electronics or to an equipotential surface. In various embodiments a ferrite is used to limit electromagnetic interference. Other approaches are possible without departing from the scope of the present subject matter.

FIGS. 6A and 6B show a top view and a bottom view of an injection molded circuit connector (IMC connector), according to one embodiment of the present subject matter. The IMC 60 includes connection pads 66, traces 67, and contacts 62. Detailed views of the traces are shown in FIGS. 6D and 6E, according to one embodiment. A side view of IMC 60 is shown in FIG. 6C. An end view of IMC 60 is

6

shown in FIG. 6F. In various embodiments, the contacts are conformed to a shape that is consistent with the IMC 60 cross section. That is shown in FIG. 6F as rounded contacts at the extreme ends of the connector. It is understood that the contacts can be patterned in a variety of shapes and configurations, without departing from the scope of the present subject matter. It is understood also that the contacts may be symmetrical or asymmetrical as desired for any particular design.

Another embodiment of IMC 60 is shown in FIGS. 6G, H, I, J, K, and L. In the embodiment shown in FIGS. 6G to 6L, the traces 67 are continuous to both ends of IMC 60 and contacts 62 can be connected to the opposite end of the connector via traces 67. Although FIGS. 6G to 6L relate to a 5 connection example, it is understood that other numbers of connections may be made without departing from the scope of the present subject matter.

IMC 60 can be used in connector 20, connector 30, or in both connectors. Use of the same IMC can reduce overall cost of manufacture and provide consistent connection designs.

FIG. 7 shows a process for construction of an IMC connector, according to one embodiment of the present subject matter. In this process the connector substrate is molded or cast 71. Such fabrication may include, but is not limited to, injection molding. The substrate is then laser patterned to provide patterns including one or more of connection pads, traces, and contacts 72. The substrate is then plated with conductive material to provide the one or more of the connection pads, traces and contacts 73. In one application, Laser Direct Structuring (LDS) technology is used to create molded interconnect devices. One such process is provided by TYCO. The processes discussed herein are used to demonstrate only some processes, but it is understood that other processes are possible without departing from the scope of the present subject matter.

In various embodiments, the electronics connected to the first connector 20 and the second connector 30 include a mating receptacle to make a positive mechanical connection and provide good electrical connections. FIGS. 8A-8E demonstrate a process for connecting a device having a faceplate to a connector of the modular connection assembly, according to one embodiment of the present subject matter. Device 80 is adapted to be worn by a user of a hearing assistance device. It has a faceplate 88 with a retainer door 82. In FIG. 8A the retainer door 82 is open to allow a connector to be inserted into receptacle 89, according to one embodiment of the present subject matter. Handle 84 is optional and may be used by the wearer to place the device 80 in or about the ear canal of the wearer. In embodiments of device 80 which include a microphone and a receiver, the five (5) point electrical connector and cable provided herein can provide microphone and receiver connections. In one embodiment, the connector 20 is inserted into the receptacle 89 and a positive stop is used to seat the connector, which mechanically compresses the conductive silicone portion 86 as discussed herein. In various embodiments a key slot molded into the retainer door 82 is used to guide the connector into the right orientation in receptacle 89 (FIG. 8B). The connector 20 is rotated to a vertical position in FIG. 8C. The retainer door 82 is closed to lock the connector 20 in place as demonstrated by FIG. 8D. The modular connection assembly 10 and device 80 are now connected both electrically and mechanically. In various embodiments, the connection is water resistant, water proof, and/or tamper proof. It is understood that other receptacle configurations and other devices may be used without departing from the scope

of the present subject matter. The other connector **30** can be attached to a RIC device, RITE device, BTE device, or some other device, including, but not limited to a device that is over the ear. One such RIC device, such as the ZON™ by Starkey Laboratories, Inc.

FIG. **9** demonstrates one example of how contacts are disposed in a receptacle, according to one embodiment of the present subject matter. A high temperature polymer is used to provide insert molded metal contacts **94** for the receptacle **90**. The nub or extension **92** can be used to make a pivoting assembly, such as with the “hanging basket” faceplate design **110** of FIG. **11**. The nubs or extensions **92** can fit into apertures **112** to make a pivoting assembly. Another design for a receptacle is found in FIG. **10**, where receptacle **100** includes a molded in flex or IMC insert **104** for contacts. Nubs or extensions **102** can fit into apertures **112** to make a pivoting assembly. In various embodiments, the nubs serve as a retention mechanism, but are not pivoting. Other receptacle and contact designs are possible without departing from the scope of the present subject matter.

FIG. **12** shows an exploded view of the modular connection assembly, according to one embodiment of the present subject matter. Plug portions **1** and **2** of connector **20** surround IMC **60**, which is soldered to wires in cable **40** in one embodiment. Plug portions **38** and **34** surround IMC **60** of connector **30**, which is soldered to the wires in cable **40** in one embodiment. FIG. **13** shows that the retainer door **82** is adapted to be mounted in faceplate **88** and a conductive silicone layer **86** is adapted to provide connections to contacts **6A** mounted in receptacle **6**.

FIG. **14** demonstrates one use of the modular connection assembly with active components, according to one embodiment of the present subject matter. The device **140** includes battery **142** which powers one or more components in device **140**. A retainer door **82** holds the connector in place and compresses the connector against conductive silicone layer **86**, which in turn provides connection to contacts **6A** disposed in the receptacle.

It is understood that various embodiments of the present subject matter provide a polymer housing and the ability to include a three-dimensional injection molded circuit which has a number of contacts. In various embodiments the injection molding (PPA, LCP) includes a 5 contact insert. The conductive silicone pad provides redundant connection and insulation bars in an existing hearing assistance device housing. It is understood that 2, 3, or 5 contacts can be utilized from the same flex.

It is understood that the modular connection assembly can be used to connect hearing assistance electronics with one or more other devices, including, but not limited to a receiver, a telecoil, a sensor, a microphone, and/or combinations thereof. In one application a receiver that is adapted to be placed in an open ear configuration is designed to connect to connector **20** and a receiver-in-the ear or RIC device is adapted to connect to connector **30**. In various embodiments, connectors **20** and **30** can be interchangeable. In various applications the receiver includes a mechanism to position the receiver within the ear canal. Other apparatus can be included, such as another receiver or one or more of a telecoil or microphone or sensor. Other variations exist without departing from the scope of the present subject matter. Some variations include, but are not limited to, the following additional combinations; however, it is understood that the present subject matter is not so limited. In various embodiments, the connections are used for a receiver connection in the ear and/or ear canal. Such designs

can provide increased performance in gain and output. In various embodiments, the connections are used for both a receiver and a telecoil placed closer to the ear canal. This allows for more enhanced usage with telephones and more natural positioning of a telecoil near the ear canal. In various embodiments, the connections are used for a receiver and one or more microphones. Such embodiments allow for directional or array microphones with enhanced directionality and/or localization. Such embodiments also provide the ability to use the connections for one or more microphones to receive sounds for real ear measurement. In various embodiments, the microphones can be situated on both sides of an ear mold or an ear bud, thereby providing sensing in the canal as well as at the opening of the ear. Consequently, the use of microphones near the ear can alleviate space limitations in the behind-the-ear or over-the-ear electronics, in various embodiments. Other sensors may be connected using the present system. For example, a GMR sensor (giant magnetoresistive sensor) or TMR (tunneling magnetoresistive sensor) may be connected using the present system. Multiple receivers can also be connected to produce devices capable of transmitting sound on either side of the ear bud or earmold to provide functions, such as noise cancellation. Additional combinations include, but are not limited to one or more microphones and a telecoil, one or more microphones and a GMR or TMR sensor, for example. Additional embodiments provide connections and optionally conductors for antennas. The present connection system also allows for rechargeable applications and technology. Thus, the present subject matter provides connections for a number of available configurations and for a variety of devices. The present connector can also be rapidly replaced for situations where the sensor and/or receiver at the end is desired to be changed. In embodiments where the components situated near the ear are integrated with the connector, the entire connector and component combination can be quickly and reliably interchanged.

FIG. **15** shows an isometric view of a microphone and receiver assembly **1500** according to one embodiment of the present subject matter. The assembly includes a microphone **1501** mounted between two receivers **1502**, **1503**. The assembly includes an acoustic spout **1504** for the microphone and an acoustic manifold **1505** with a port **1506** for the two receivers. In various embodiments, the microphone does not include a spout. The proximity of a microphone to a receiver in hearing assistance devices and the respective boundary conditions has been a factor in managing feedback. These constraints, historically, have negatively affected the final size of hearing assistance devices because the necessary suspension systems and multi layer barriers add size. The assembly **1500** reduces the need for the support systems and barriers by placing the microphone **1501** between two receivers **1502**, **1503** oriented such that the receiver diaphragms counteract each other in a manner that substantially negates receiver vibration paths into the microphone **1501**. In various embodiments, the assembly **1500** is enclosed in a housing adapted for wearing in the ear of a user.

FIG. **16** shows an isometric view of a microphone receiver assembly **1610** according to one embodiment of the present subject matter with the microphone **1611** offset between the two receivers **1612**, **1613**. Such a configuration reduces the size of the receiver manifold **1616** from the embodiment of FIG. **15** and provides additional separation between the microphone input **1614** and the receiver opening **1615**. As illustrated in FIG. **16**, the dimensions of the microphone **1611**, such as the width, may be different than

the dimensions of the receivers **1612**, **1613** in various embodiments. Acoustic requirements of each application of the assembly often dictate the dimension of the receivers, the microphone or the receivers and the microphone. In some embodiments, the assembly connects to a connector assembly according to the present subject matter for further connection to a second device. The second device can include, for example, but is not limited to, a behind-the-ear type device, a receiver-in-the-ear (receiver-in-the-canal) type device, or an over the ear type of device.

In various embodiments, the components of the microphone receiver assembly are mounted rigidly to each other to form the assembly and to reduce additional vibration sources. Mounting techniques include, but are not limited to, mechanical fasteners, welding including laser welding, and gluing.

FIG. **17** shows a modular connection assembly with an integrated telecoil according to one embodiment of the present subject matter. A receiver, contained in upper housing **1701** is connected to the modular connection assembly **1702**. In various embodiments the connection is performed using a first connector, encased in lower housing **1703** which provides electrical and mechanical connections to the receiver. The modular connection assembly **1702** includes a second connector **1704** for connecting to a hearing assistance device. The lower housing **1703** is attached to a flexible retention device **1705** with an integrated telecoil **1706**. The retention device conforms to a wearer's ear anatomy so that the receiver in upper housing **1701** is retained within a user's ear in a stable and comfortable manner. In various embodiments, such as that demonstrated by FIG. **17**, the telecoil **1706** is positioned at a distal end of the retention device **1705**. The retention device **1705** includes conducting wires to connect the telecoil **1716** to connector **1704**. Such conductors may include contacts which are detachable at lower housing **1703**. These contacts can be a separate connector for quick assembly and disassembly, or can be soldered to make the connection. In various embodiments, the conductors from telecoil **1706** extend through the modular connection assembly **1702** to connector **1704**. In various embodiments, such as that demonstrated in FIG. **18**, the telecoil **1815** is located near the receiver in upper housing **1810** so that the distal end of the retention device **1814** can be trimmed if desired without affecting the electrical nature of the device. This provides the ability to customize retention device **1814** of modular connection assembly **1811**. The connections of the telecoil **1815** can be made by a variety of connector and wiring options including those discussed above for the design of FIG. **17**. Thus, a connector in lower housing **1812** can be used to make connections between connector **1813** and a receiver in upper housing **1810** and the telecoil **1815** using the five (5) wire (or other number of wires) harness set forth herein.

FIG. **19** shows an exploded view of a modular connection assembly **1920** for a receiver with an integrated telecoil, according to one embodiment of the present subject matter. The modular connection assembly includes a connector portion **1921**, cable tubing **1922**, receiver assembly **1923** and a telecoil assembly **1924**. The receiver assembly **1923** is configured for positioning a receiver in an ear of a wearer. The receiver assembly **1923** includes an upper housing **1925**, a lower housing **1926** and a receiver **1927**. The upper **1925** and lower **1926** receiver housings enclose the receiver **1927**. Such receivers include, but are not limited to a Pulse 4400 receiver or a Knowles FK receiver. It is understood that other receivers may be used without departing from the

scope of the present subject matter. The receiver **1927** is electrically connected to conductors (not shown) passing through the cable tube **1922**. In various embodiments, the conductors are soldered to the receiver **1927**. In various embodiments, receiver conductors are a twisted pair of conductors.

As demonstrated by the embodiment of FIG. **19**, the telecoil assembly **1924** couples to the receiver assembly **1923**. The telecoil assembly **1924** includes a telecoil housing **1928**, a telecoil **1929** and a retention element **1930**. The telecoil housing **1928** assembles with the upper **1925** and lower **1926** receiver housings. Telecoil conductors pass through a conduit in the connecting portion **1931** of the telecoil housing **1928** from the lower receiver housing **1926** to connect to the telecoil **1929**, such as a TA32, 3-pin active telecoil, for example. It is understood that other telecoils may be used with the telecoil assembly without departing from the scope of the present subject matter, including, but not limited to, other active telecoils, other 3-pin telecoils, and 2-pin telecoils, including passive telecoils. In various embodiments other magnetic sensing and/or demodulating sensors are employed. For example, a GMR or TMR sensor may be used in conjunction with or instead of the telecoil, according to various embodiments. In various embodiments, the telecoil **1929** (or other sensor) is soldered to shielded conductors and is enclosed in the telecoil housing upon assembly. A flexible retention element **1930** couples to the telecoil housing **1928** to enclose the telecoil **1929**. The retention element **1930** is designed to conform to a wearer's ear anatomy so that the receiver assembly **1923** is retained within the wearer's ear in a stable and comfortable manner. It can be trimmed to a desired length for a better fit if needed.

Conductors pass through cable tubing **1922** that is coupled to the lower housing **1926** of the receiver assembly **1923**. The tubing **1922** can be made of any flexible material, including, but not limited to, PEBAX. Reinforced tubing, such as reinforced PEBAX may be used. Opposite the receiver assembly **1923**, the tubing **1922** connects to a connector assembly **1921**. In various embodiments, the connector assembly **1921** is a generic connector for connecting the modular connection assembly **1920** to the electronics of a hearing assistance device. In some embodiments, the connector assembly **1921** is a connector assembly according to the present subject matter (see FIG. **12**, assembly **30** and FIG. **6** generally). The illustrated connector assembly **1921** includes a strain relief **1931** for connecting to the cable tube **1922**, a molded interconnect device **1932** for connecting to conductors in the cable tube **1922** and a connector housing **1933** to retain the interconnect device **1932** in the strain relief **1931** and mechanically couple the connector assembly **1921** to a hearing assistance device such as a RIC hearing assistance device, for example. The molded interconnect device **1932** includes connection pads, traces, and contacts for connecting to conductors in the cable tube and providing contacts for electrically connecting modular connection assembly **1920** to a hearing assistance device. In various embodiments, conductors from in the cable tube **1922** are soldered to contact pads of the molded interconnect device **1932**. In some embodiments, the molded interconnect device **1932** uses conductive silicone to connect to a hearing assistance device. Several embodiments are provided herein. It is understood that other methods of connecting the conductors to the molded interconnect device and the molded interconnect device to a hearing assistance device are possible without departing from the scope of the present subject matter.

11

FIG. 20 shows a cross-section view of a portion of an assembled modular connection assembly 2040 according to one embodiment of the present subject matter. The view includes an upper receiver housing 2041 and a lower receiver housing 2042 enclosing a receiver 2043. The upper receiver housing 2041 includes an acoustic opening 2044 for directing sound from the receiver 2043 to a wearer's ear. The assembled upper 2041 and lower 2042 receiver housings form an opening 2045 for coupling a telecoil assembly 2046 to the upper and lower receiver housings. The telecoil assembly 2046 includes a telecoil housing 2047, telecoil 2048 and retention element 2049. The telecoil housing 2047 includes a cavity 2050 for housing the telecoil 2048. A retention element 2049 couples to the telecoil housing 2047 to enclose the cavity 2050. The retention element 2049 is designed to conform to a wearer's ear anatomy so that the receiver assembly 2051 is retained within the wearer's ear in a stable and comfortable manner. A connecting portion 2052 of the telecoil housing includes a conduit 2053 for passing telecoil conductors from the lower receiver housing 2042 to the telecoil 2048 in the cavity 2050. The lower receiver housing 2042 includes a cable opening 2054 for coupling to cable tubing 2055. Cable tubing protects receiver and telecoil conductors. The tubing 2054 can be made of any flexible material, including, but not limited to, PEBAX. Reinforced tubing, such as reinforced PEBAX may be used.

The telecoil (or other sensor) can be eliminated by changing the modular connection assembly if desired, as opposed to purchasing a different hearing assistance device without a telecoil. The external location of the telecoil (or other sensor) allows for better sensing of local magnetic fields for switching the hearing assistance device into a telecoil mode. In some cases, the removal of the telecoil from an electronics housing, such as the housings used in a receiver-in-the-ear (RIC) design, make smaller housing designs possible. Manufacturing simplicity can be increased by placing the telecoil in the retention mechanism. Such designs can be pre-tested to assure proper operation of the telecoil portion of the device. Such designs may provide less product variability and more operational reliability than designs where the telecoil is mounted in the electronics housing of the RIC device.

It is understood that other positions of the telecoil or other sensor along the length of the retention mechanism are possible without departing from the scope of the present subject matter. In various embodiments, a shielded housing for the receiver reduces interference between the telecoil and the receiver. One type of shielding is magnetic shielding, such as mu-metal. It is understood that other magnetically permeable materials and apparatus can be used to form a shield about the receiver without departing from the scope of the present subject matter.

The present subject matter includes hearing assistance devices, including, but not limited to, cochlear implant type hearing devices, hearing aids, such as behind-the-ear (BTE), receiver-in-the-canal (RIC), receiver-in-the-ear (RITE), and such devices that include in-the-ear (ITE), in-the-canal (ITC), or completely-in-the-canal (CIC) type components. It is understood that behind-the-ear type hearing aids may include devices that reside substantially behind the ear or over the ear. Such devices may include hearing aids with receivers associated with the electronics portion of the behind-the-ear device, or hearing aids of the type having receivers in-the-canal. It is understood that other hearing assistance devices not expressly stated herein may fall within the scope of the present subject matter.

12

This application is intended to cover adaptations and variations of the present subject matter. It is to be understood that the above description is intended to be illustrative, and not restrictive. The scope of the present subject matter should be determined with reference to the appended claim, along with the full scope of legal equivalents to which the claims are entitled.

What is claimed is:

1. A method for connecting hearing assistance electronics within a housing of a hearing assistance device for a wearer having an ear canal to a receiver configured to be placed in or about the ear canal, the method comprising:

providing a first injection-molded connector connected to a plurality of wires, the connector adapted for connection to the hearing assistance device electronics, wherein the receiver is configured to be connected to at least a pair of the plurality of wires and wherein the first connector includes a two part plug and connection pad; and

providing one or more electronic components outside of the housing and configured to be connected to at least one wire of the plurality of wires.

2. The method of claim 1, further comprising providing a second connector adapted to connect to a behind-the-ear housing.

3. The method of claim 2, wherein at least one of the first connector and the second connector is adapted to connect using an elastomeric component including a conductive portion.

4. The method of claim 3, wherein the elastomeric component includes conductive silicone.

5. The method of claim 1, wherein the plurality of wires includes a twisted pair.

6. The method of claim 1, wherein the plurality of wires includes a plurality of shielded wires.

7. The method of claim 1, wherein the one or more electronic components includes one or more microphones.

8. The method of claim 1, wherein the one or more electronic components includes a battery.

9. The method of claim 1, wherein a telecoil is disposed in a flexible retention element adapted to hold the housing in or about the ear canal.

10. The method of claim 1, wherein the housing includes a standard fit ear bud.

11. The method of claim 1, wherein the housing includes a custom fit ear mold.

12. The method of claim 1, wherein the hearing assistance device is a receiver-in-the-canal device.

13. The method of claim 1, wherein the hearing assistance device is an over-the-ear device.

14. The method of claim 1, wherein providing the first connector includes laser patterning a substrate to provide connection pads, traces or contacts.

15. The method of claim 14, comprising using laser direct structuring (LDS) to plate the substrate with a conductive material.

16. A method, comprising:

providing a first connector connected to a plurality of wires disposed within a cable, the first connector including first contacts and adapted for connection to hearing assistance device electronics within a housing of a hearing assistance device, wherein the first connector includes a two part plug and connection pad;

providing a second connector connected to the plurality of wires, the second connector including second contacts and adapted to connect to a receiver configured to be worn in or about an ear of a wearer of the hearing

assistance device, the receiver configured to be connected to at least a pair of the plurality of wires, and wherein one or more electronic components outside of the housing and the ear are configured to be connected to at least one wire of the plurality of wires; and 5
providing a locking mechanism of the hearing assistance device including a retaining mechanism of a mating receptacle to make a positive mechanical connection and provide a good electrical connection to the first connector, and wherein the first connector and second 10
connector are adapted for detachable connection for rapid replacement of the plurality of wires or the receiver.

17. The method of claim **16**, wherein the one or more electrical components is a telecoil is disposed in a flexible 15
retention element.

18. The method of claim **16**, wherein the one or more electrical components is a GMR sensor disposed in a flexible retention element.

19. The method of claim **16**, wherein the one or more 20
electrical components is a TMR sensor disposed in a flexible retention element.

20. The method of claim **16**, wherein the one or more electrical components is an antenna.

* * * * *