



US010254890B2

(12) **United States Patent**
Hotelling et al.

(10) **Patent No.:** **US 10,254,890 B2**
(45) **Date of Patent:** ***Apr. 9, 2019**

(54) **FRONT-END SIGNAL COMPENSATION**

(56) **References Cited**

(71) Applicant: **Apple Inc.**, Cupertino, CA (US)

U.S. PATENT DOCUMENTS

(72) Inventors: **Steve Porter Hotelling**, Los Gatos, CA (US); **Brian Richards Land**, Woodside, CA (US)

4,090,408 A 5/1978 Hedrick
4,415,927 A 11/1983 Penney
(Continued)

(73) Assignee: **Apple Inc.**, Cupertino, CA (US)

FOREIGN PATENT DOCUMENTS

(*) Notice: Subject to any disclaimer, the term of this patent is extended or adjusted under 35 U.S.C. 154(b) by 270 days.

DE 10 2005 038875 A1 11/2006
JP 2000-163031 A 6/2000
(Continued)

This patent is subject to a terminal disclaimer.

OTHER PUBLICATIONS

(21) Appl. No.: **15/093,638**

Final Office Action dated Oct. 26, 2011, for U.S. Appl. No. 11/650,038, filed Jan. 3, 2007, 12 pages.

(22) Filed: **Apr. 7, 2016**

(Continued)

(65) **Prior Publication Data**

US 2016/0224185 A1 Aug. 4, 2016

Related U.S. Application Data

Primary Examiner — Jennifer T Nguyen

(74) *Attorney, Agent, or Firm* — Morrison & Foerster LLP

(63) Continuation of application No. 14/042,462, filed on Sep. 30, 2013, now Pat. No. 9,323,405, which is a (Continued)

(57) **ABSTRACT**

(51) **Int. Cl.**
G06F 3/041 (2006.01)
G06F 3/044 (2006.01)

(52) **U.S. Cl.**
CPC **G06F 3/0418** (2013.01); **G06F 3/044** (2013.01); **G06F 2203/04104** (2013.01); **G06F 2203/04107** (2013.01)

(58) **Field of Classification Search**
CPC . G06F 2203/04107; G06F 2203/04111; G06F 2203/04112; G06F 2203/04113;
(Continued)

A touch surface device having improved sensitivity and dynamic range is disclosed. In one embodiment, the touch surface device includes a touch-sensitive panel having at least one sense node for providing an output signal indicative of a touch or no-touch condition on the panel; a compensation circuit, coupled to the at least one sense node, for generating a compensation signal that when summed with the output signal removes an undesired portion of the output signal so as to generated a compensated output signal; and an amplifier having an inverting input coupled to the output of the compensation circuit and a non-inverting input coupled to a known reference voltage.

20 Claims, 9 Drawing Sheets

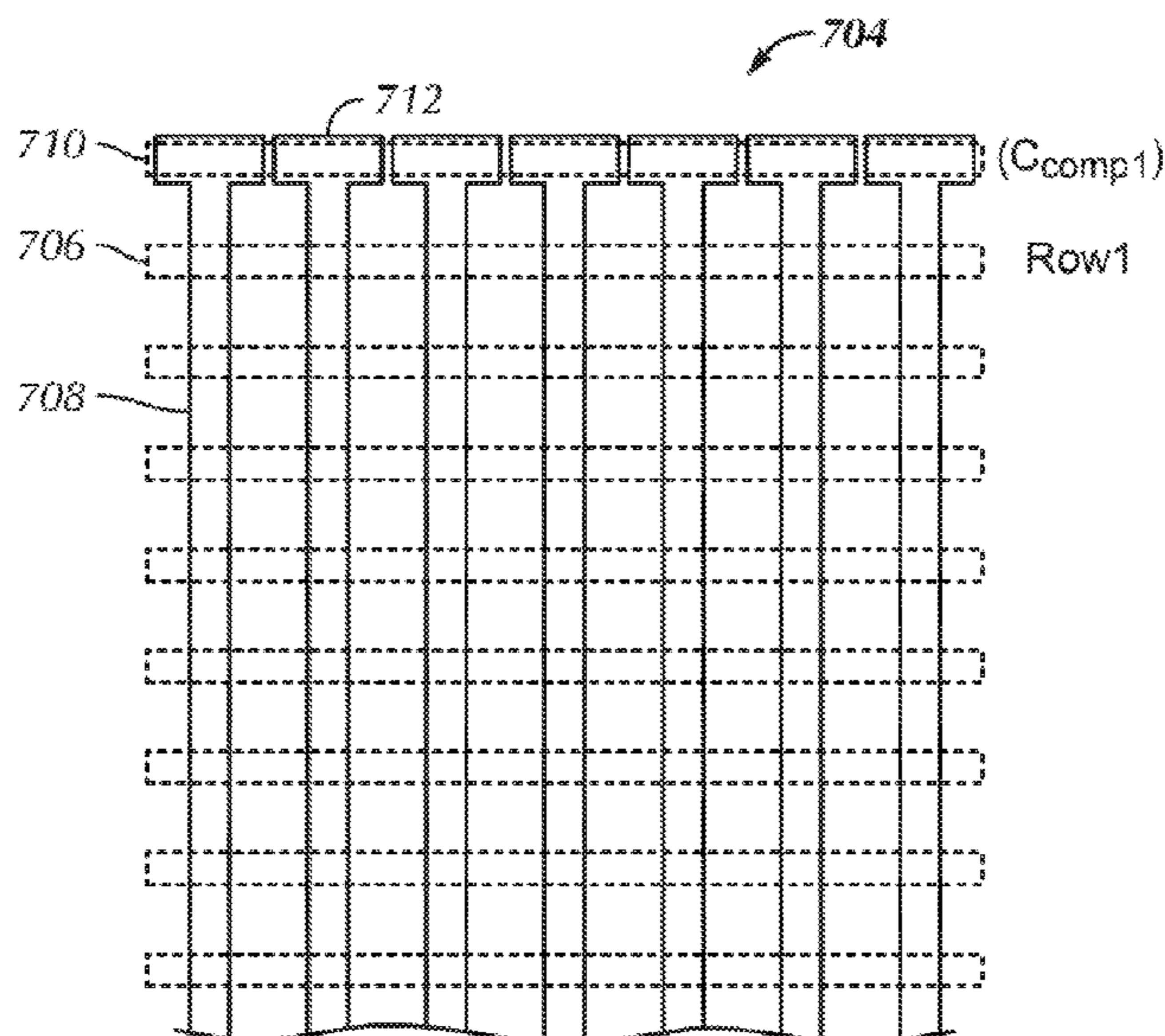

Related U.S. Application Data

continuation of application No. 13/284,732, filed on Oct. 28, 2011, now Pat. No. 8,553,004, which is a continuation of application No. 11/650,043, filed on Jan. 3, 2007, now Pat. No. 8,049,732.

(58) **Field of Classification Search**

CPC G06F 3/0418; G06F 3/044; G06F 2203/04104; H05K 1/0287; H05K 1/0289; H05K 1/0296
 USPC 345/173-178; 178/18.06
 See application file for complete search history.

(56) **References Cited**

U.S. PATENT DOCUMENTS

4,988,983	A	1/1991	Wehrer	
5,149,919	A	9/1992	Greanias	
5,483,261	A	1/1996	Yasutake	
5,488,204	A	1/1996	Mead et al.	
5,508,656	A	4/1996	Jaffard et al.	
5,565,658	A	10/1996	Gerpheide et al.	
5,825,352	A	10/1998	Bisset et al.	
5,835,079	A	11/1998	Shieh	
5,880,411	A	3/1999	Gillespie et al.	
5,920,309	A *	7/1999	Bisset	G06F 3/044 178/18.06
6,049,246	A	4/2000	Kozisek et al.	
6,087,897	A	7/2000	Wang	
6,140,872	A	10/2000	McEldowney	
6,141,169	A	10/2000	Pietruszynski et al.	
6,188,391	B1	2/2001	Seely et al.	
6,310,610	B1	10/2001	Beaton et al.	
6,323,846	B1	11/2001	Westerman et al.	
6,466,036	B1	10/2002	Phillip	
6,570,557	B1	5/2003	Westerman et al.	
6,677,932	B1	1/2004	Westerman	
6,690,387	B2	2/2004	Zimmerman et al.	
6,781,450	B1	8/2004	Mercer et al.	
6,888,536	B2	5/2005	Westerman et al.	
7,015,894	B2	3/2006	Morohoshi	
7,132,882	B2	11/2006	Chen et al.	
7,138,856	B2	11/2006	Laletin	
7,184,064	B2	2/2007	Zimmerman et al.	
7,253,680	B2	8/2007	Laletin	
7,277,087	B2	10/2007	Hill et al.	
7,304,534	B2	12/2007	Koller et al.	
7,315,300	B2	1/2008	Hill et al.	
7,327,190	B2	2/2008	D'Abramo et al.	
RE40,153	E	3/2008	Westerman et al.	
7,339,580	B2	3/2008	Westerman et al.	
7,557,590	B2	7/2009	Yakabe	
RE40,993	E	11/2009	Westerman	
7,614,008	B2	11/2009	Ording	
7,663,607	B2	2/2010	Hotelling et al.	
7,844,914	B2	11/2010	Andre et al.	
8,049,732	B2	11/2011	Hotelling et al.	
8,479,122	B2	7/2013	Hotelling et al.	
8,553,004	B2	10/2013	Hotelling et al.	
8,711,129	B2	4/2014	Hotelling et al.	
8,884,890	B2 *	11/2014	Hotelling	G06F 3/0416 178/18.01
9,075,491	B2 *	7/2015	Hotelling	G06F 3/0416
9,465,502	B2 *	10/2016	Hotelling	G06F 3/0416
9,836,160	B2 *	12/2017	Hotelling	G06F 3/0416
2002/0011991	A1	1/2002	Iwasaki et al.	
2003/0067451	A1	4/2003	Tagg et al.	
2004/0012439	A1	1/2004	Chen et al.	
2005/0146513	A1	7/2005	Hill et al.	
2005/0260965	A1	11/2005	Ranganathan et al.	
2005/0275415	A1 *	12/2005	Sato	G06F 3/046 324/662

2006/0026521	A1	2/2006	Hotelling et al.
2006/0026535	A1	2/2006	Hotelling et al.
2006/0026536	A1	2/2006	Hotelling et al.
2006/0033724	A1	2/2006	Chaudhri et al.
2006/0053387	A1	3/2006	Ording
2006/0085757	A1	4/2006	Andre et al.
2006/0097991	A1	5/2006	Hotelling et al.
2006/0186954	A1	8/2006	Koller et al.
2006/0197753	A1	9/2006	Hotelling
2006/0232567	A1	10/2006	Westernman et al.
2007/0074913	A1	4/2007	Geaghan et al.
2007/0109274	A1	5/2007	Reynolds
2007/0291011	A1	12/2007	Chang
2008/0018618	A1	1/2008	Hill et al.
2008/0088595	A1	4/2008	Liu et al.
2008/0111560	A1	5/2008	Regier
2008/0158172	A1	7/2008	Hotelling et al.
2008/0158175	A1	7/2008	Hotelling et al.
2008/0158178	A1	7/2008	Hotelling et al.
2008/0158180	A1	7/2008	Krah et al.
2008/0191713	A1	8/2008	Hauer et al.
2010/0073317	A1	3/2010	Hasegawa
2012/0038581	A1	2/2012	Hotelling
2014/0028621	A1	1/2014	Hotelling

FOREIGN PATENT DOCUMENTS

JP	2002-342033	A	11/2002
WO	WO-2006/132960	A1	12/2006
WO	WO-2006/132960	B1	12/2006
WO	WO-2008/085419	A1	7/2008

OTHER PUBLICATIONS

International Search Report dated May 8, 2008, for PCT Application No. PCT/US2007/026187, filed Dec. 21, 2007, two pages.

Lee, S.K. et al. (Apr. 1985). "A Multi-Touch Three Dimensional Touch-Sensitive Tablet," *Proceedings of CHI: ACM Conference on Human Factors in Computing Systems*, pp. 21-25.

Non-Final Office Action dated Oct. 15, 2010, for U.S. Appl. No. 11/650,038, filed Jan. 3, 2007, eight pages.

Non-Final Office Action dated Mar. 24, 2011, for U.S. Appl. No. 11/650,038, filed Jan. 3, 2007, 11 pages.

Non-Final Office Action dated May 7, 2012, for U.S. Appl. No. 13/284,732, filed Oct. 28, 2011, 10 pages.

Non-Final Office Action dated Sep. 11, 2012, for U.S. Appl. No. 11/650,038, filed Jan. 3, 2007, 9 pages.

Non-Final Office Action dated May 21, 2013, for U.S. Appl. No. 11/650,038, filed Jan. 3, 2007, 8 pages.

Non-Final Office Action dated Jul. 1, 2015, for U.S. Appl. No. 14/042,462, filed Sep. 30, 2013, nine pages.

Notice of Allowance dated Jul. 1, 2013, for U.S. Appl. No. 13/284,732, filed Oct. 28, 2011, 6 pages.

Notice of Allowance dated Dec. 30, 2013, for U.S. Appl. No. 11/650,038, filed Jan. 3, 2007, 6 pages.

Notice of Allowance dated Dec. 30, 2015, for U.S. Appl. No. 14/042,462, filed Sep. 30, 2013, five pages.

Rubine, D.H. (Dec. 1991). "The Automatic Recognition of Gestures," CMU-CS-91-202, Submitted in Partial Fulfillment of the Requirements for the Degree of Doctor of Philosophy in Computer Science at Carnegie Mellon University, 285 pages.

Rubine, D.H. (May 1992). "Combining Gestures and Direct Manipulation," CHI '92, pp. 659-660.

Westerman, W. (Spring 1999). "Hand Tracking, Finger Identification, and Chordic Manipulation on a Multi-Touch Surface," A Dissertation Submitted to the Faculty of the University of Delaware in Partial Fulfillment of the Requirements for the Degree of Doctor of Philosophy in Electrical Engineering, 364 pages.

* cited by examiner

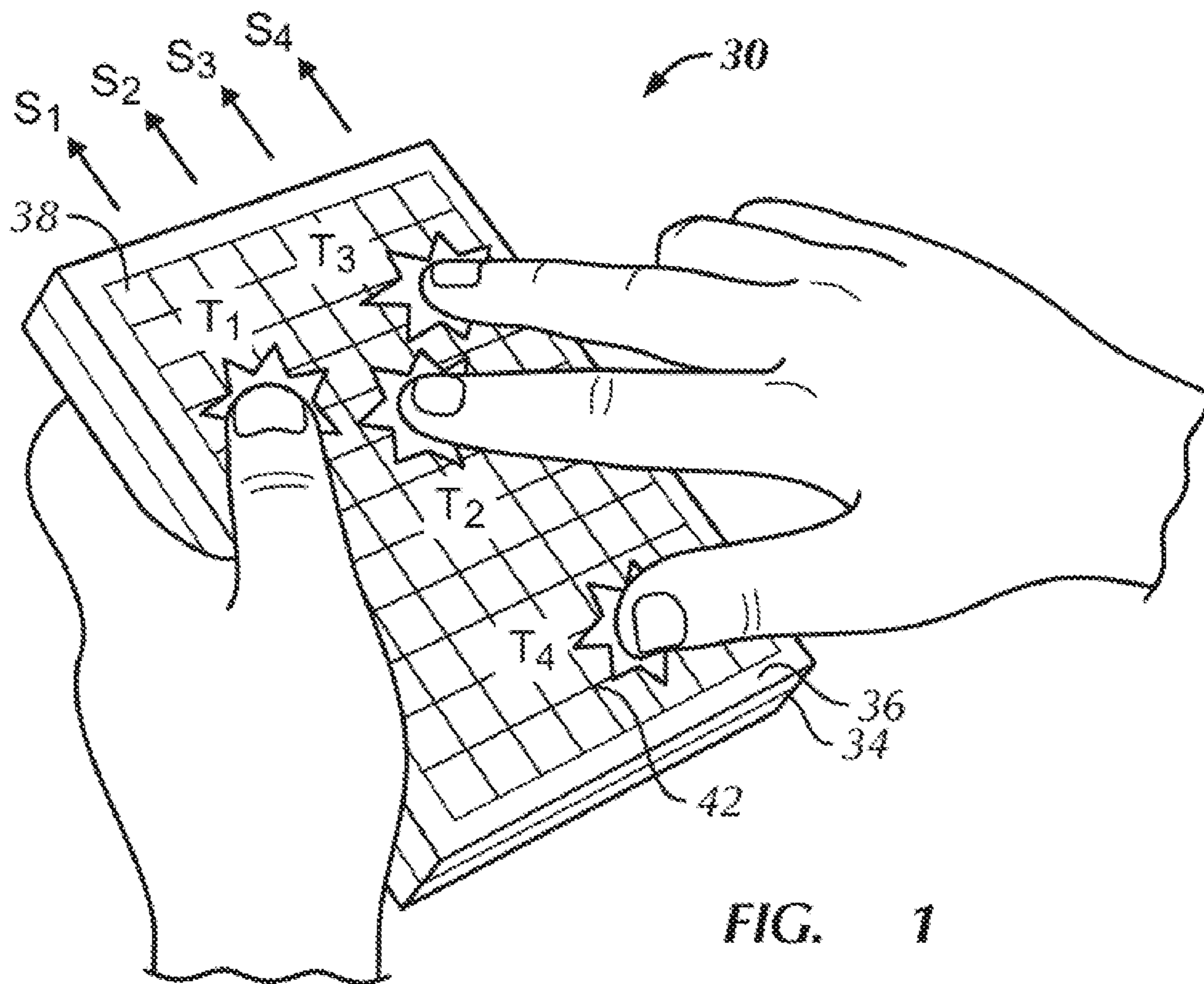

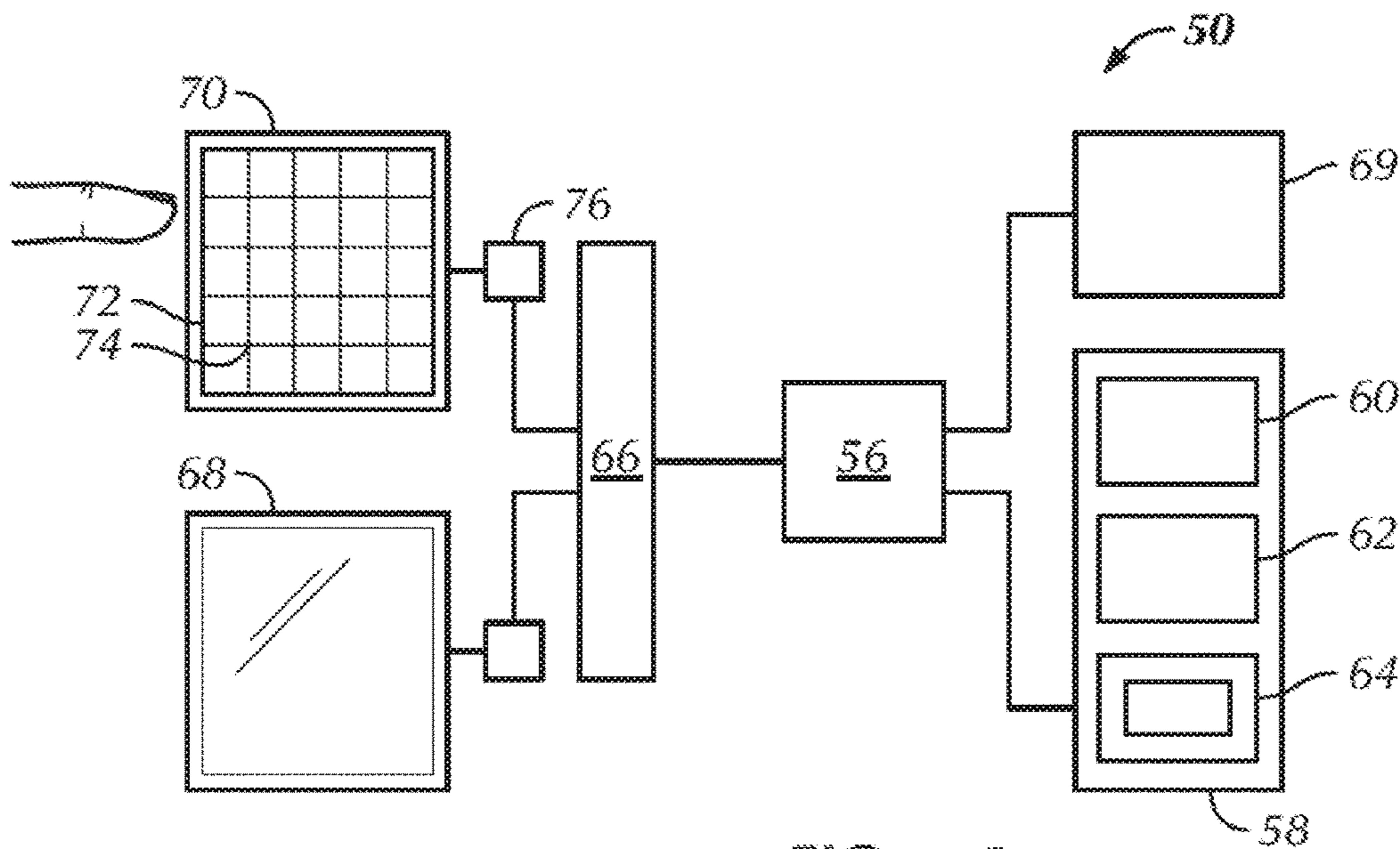

FIG. 2

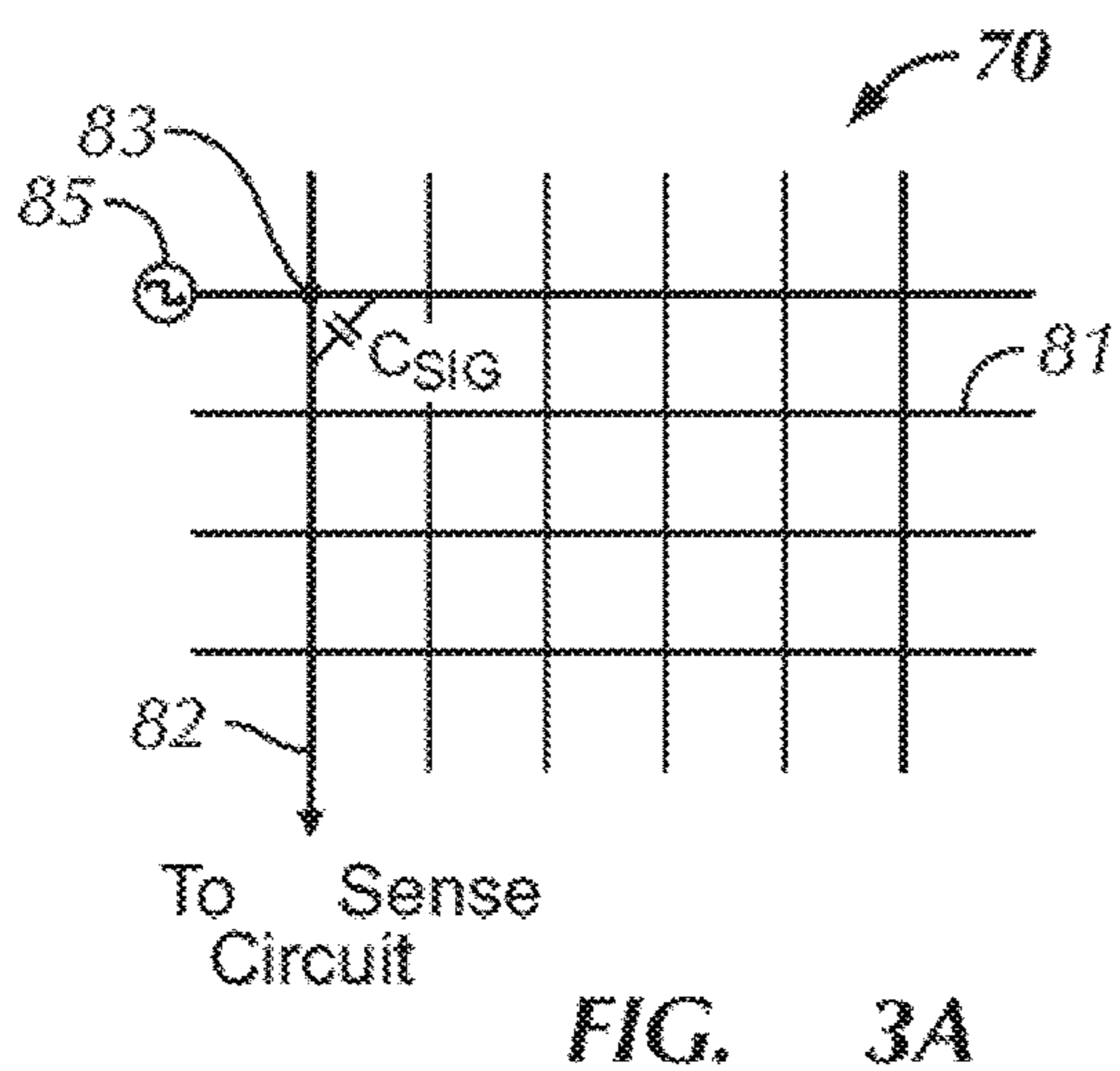

FIG. 3A

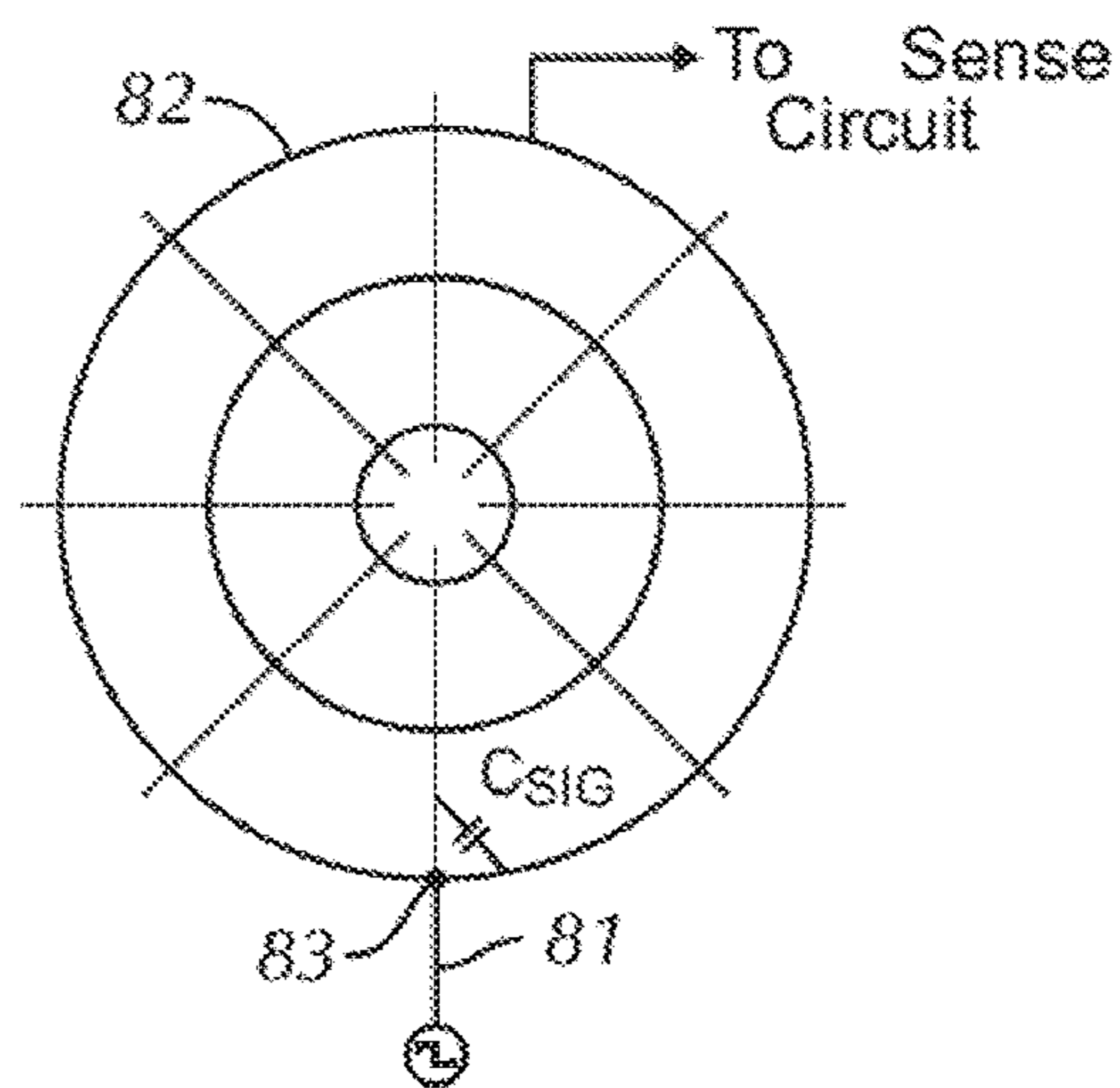

FIG. 3B

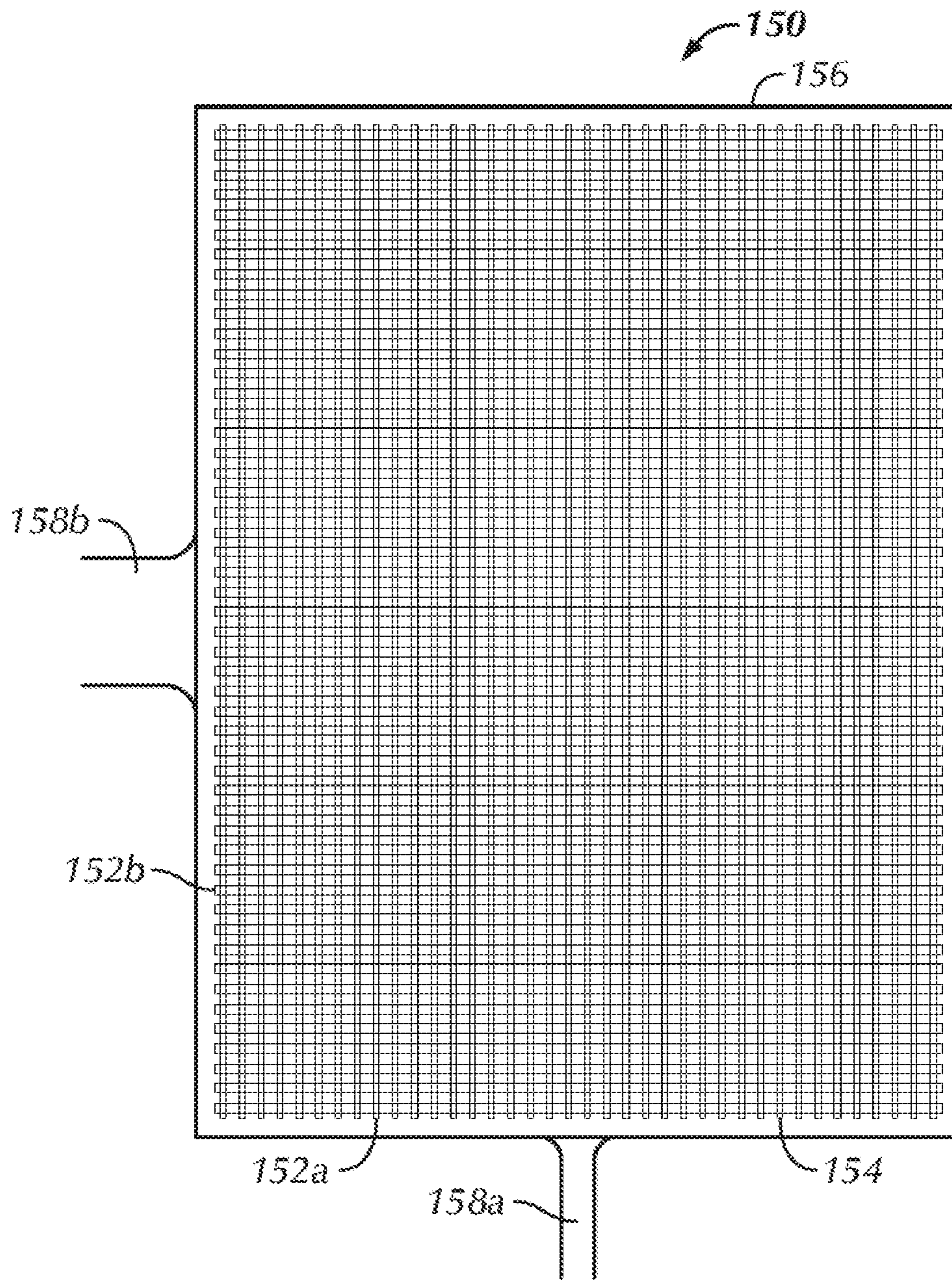

FIG. 4

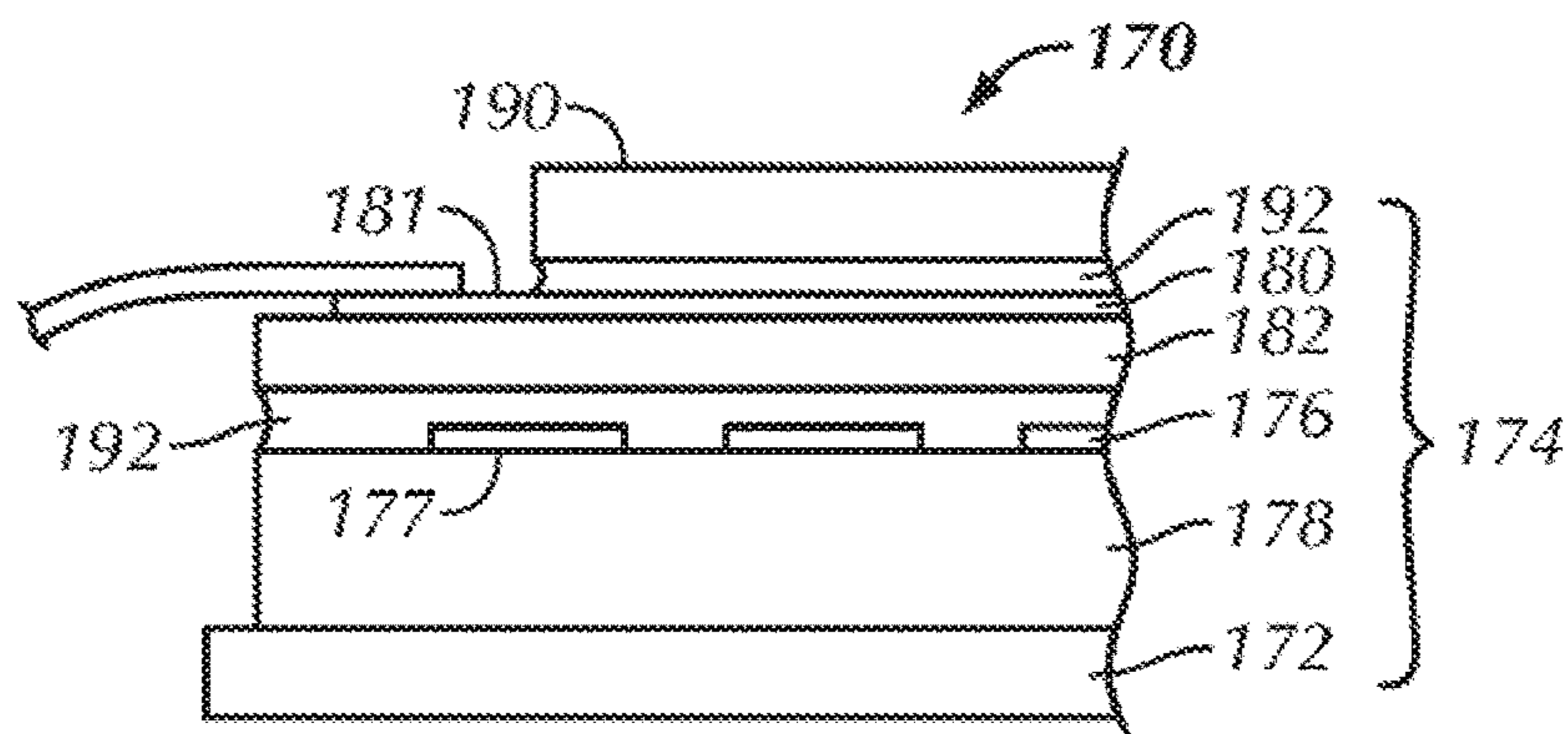

FIG. 5

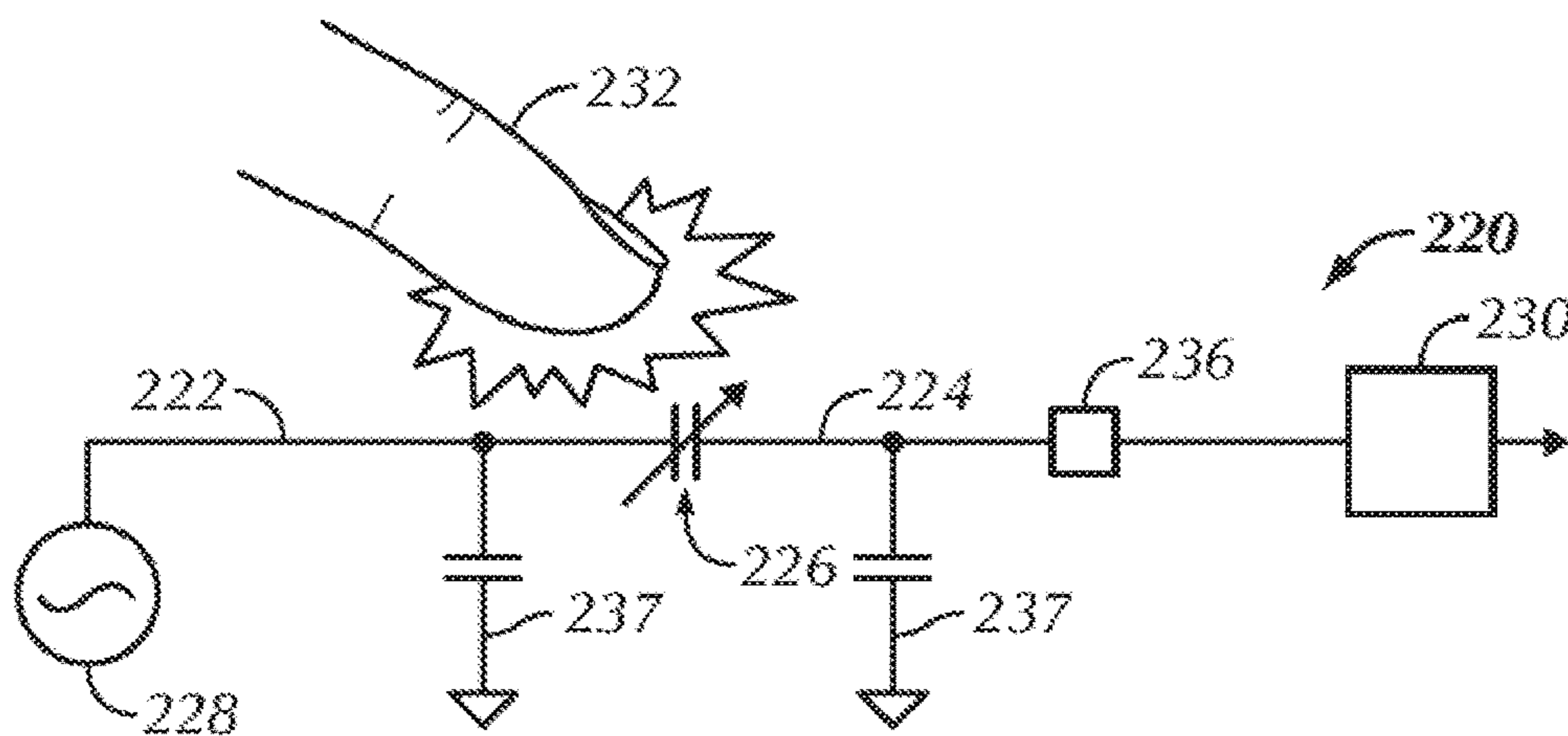

FIG. 6

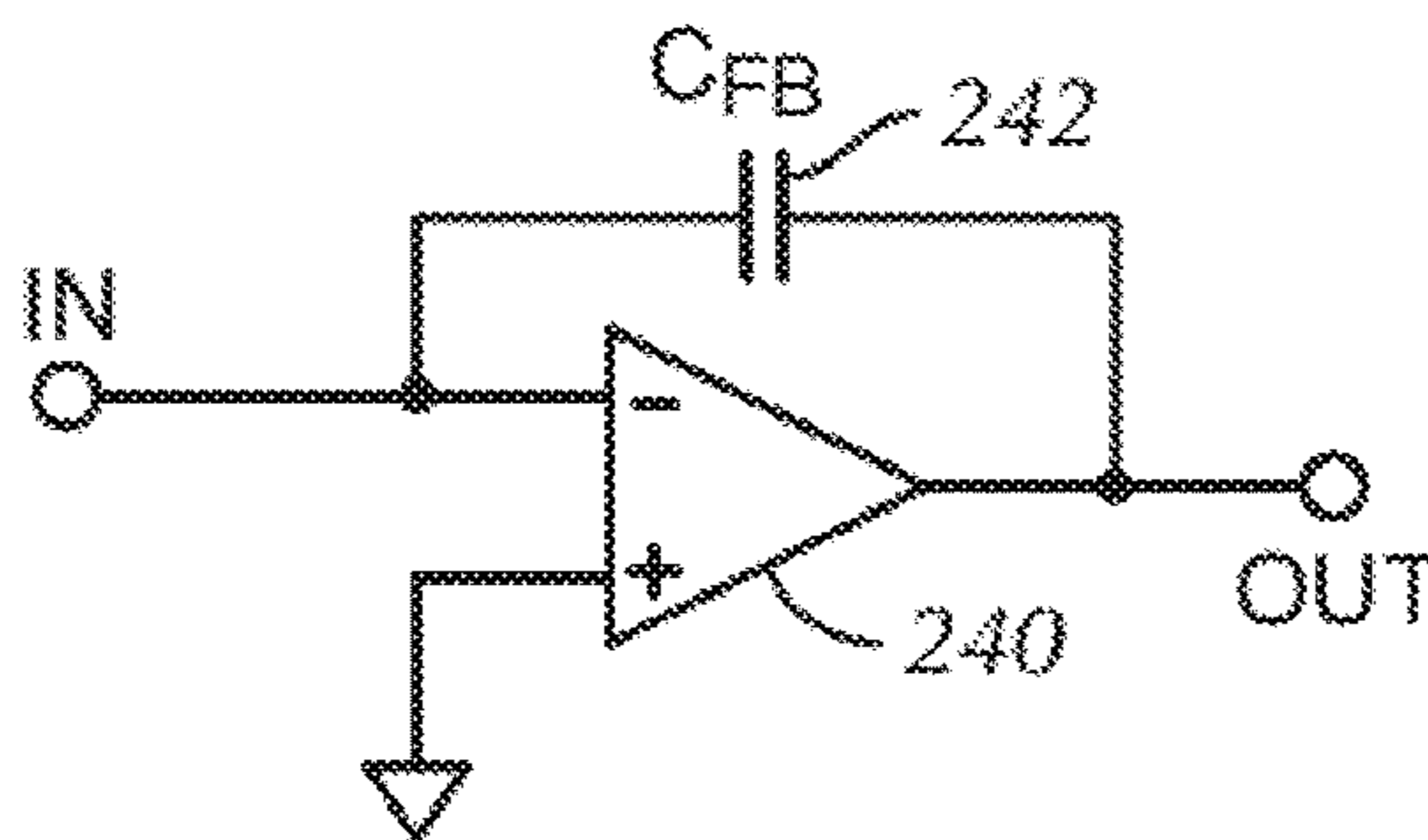

FIG. 7

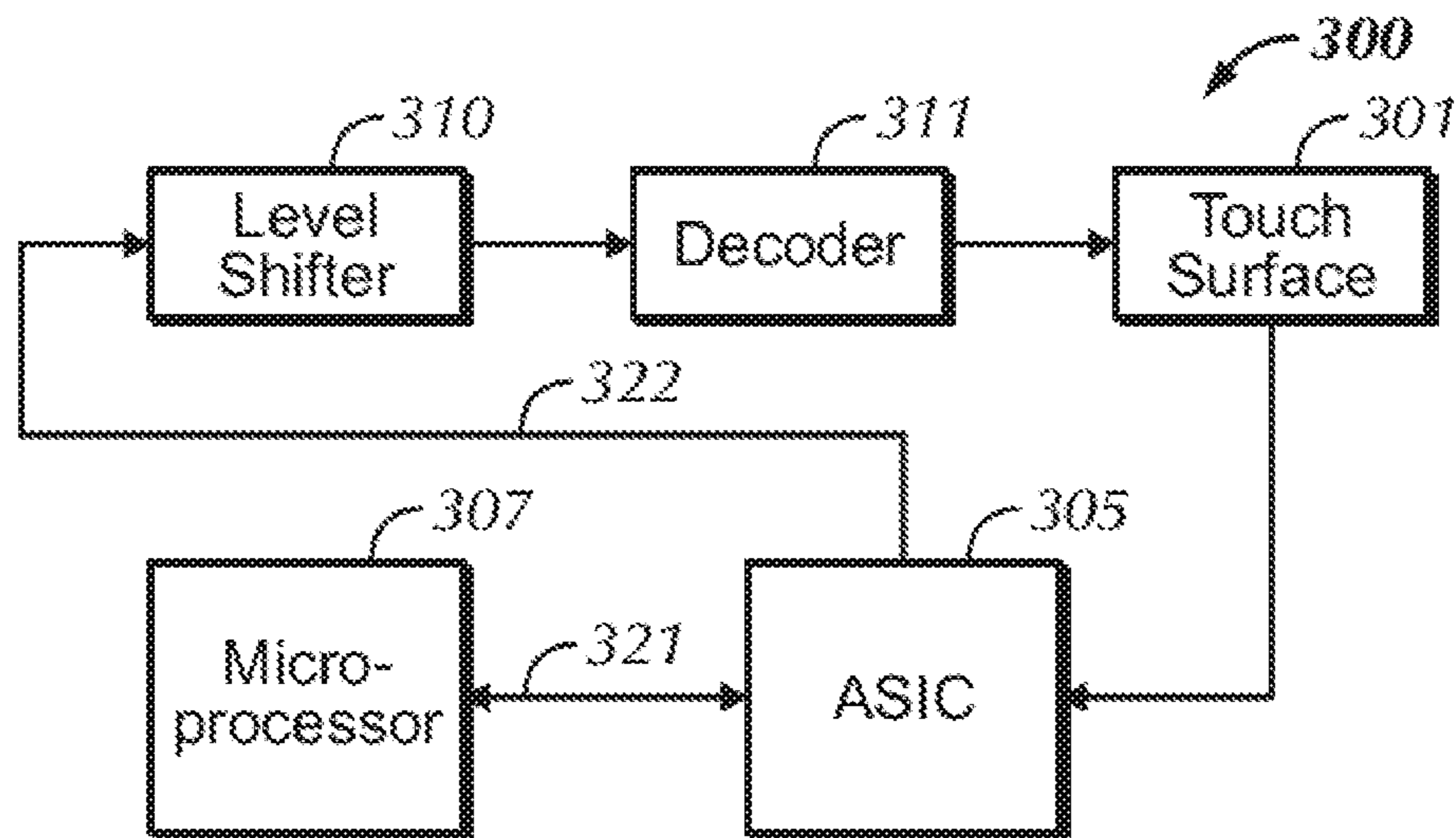

FIG. 8

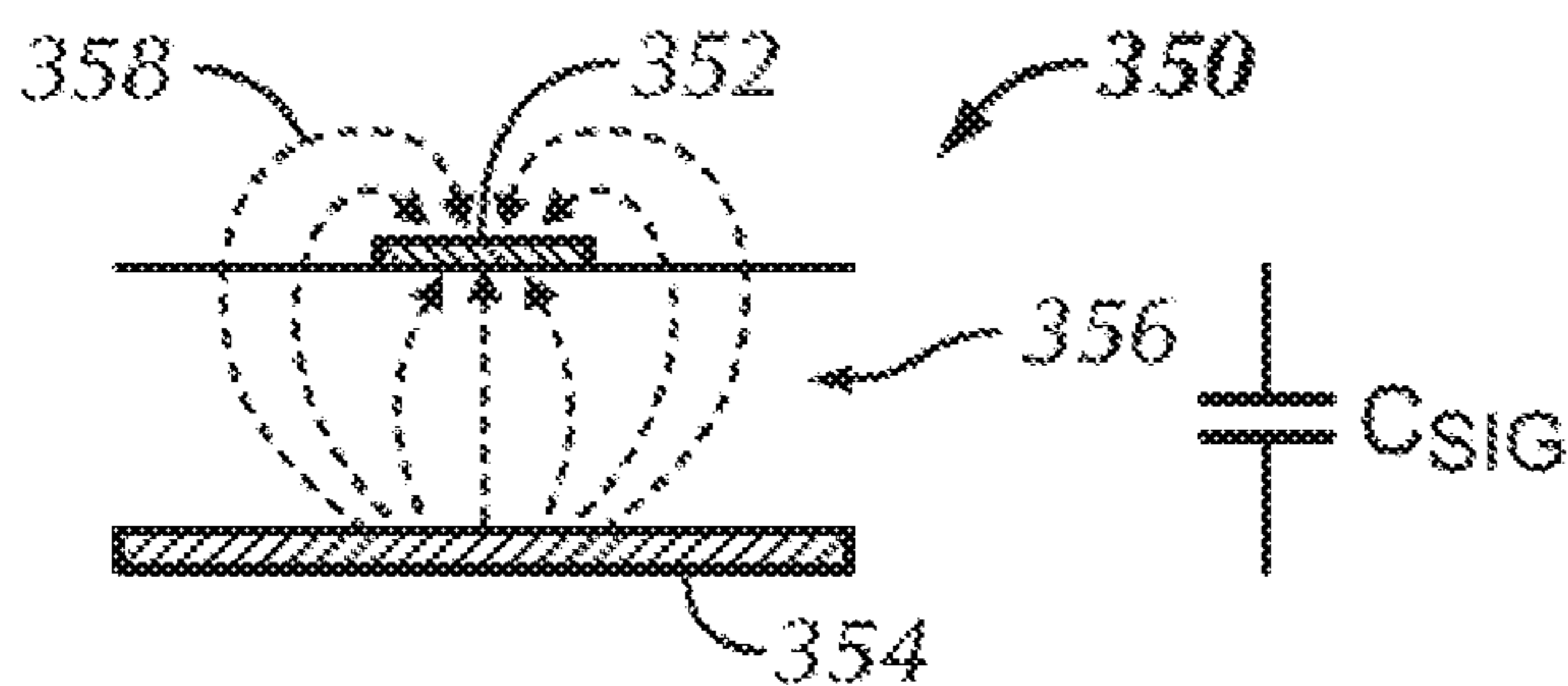

FIG. 9A

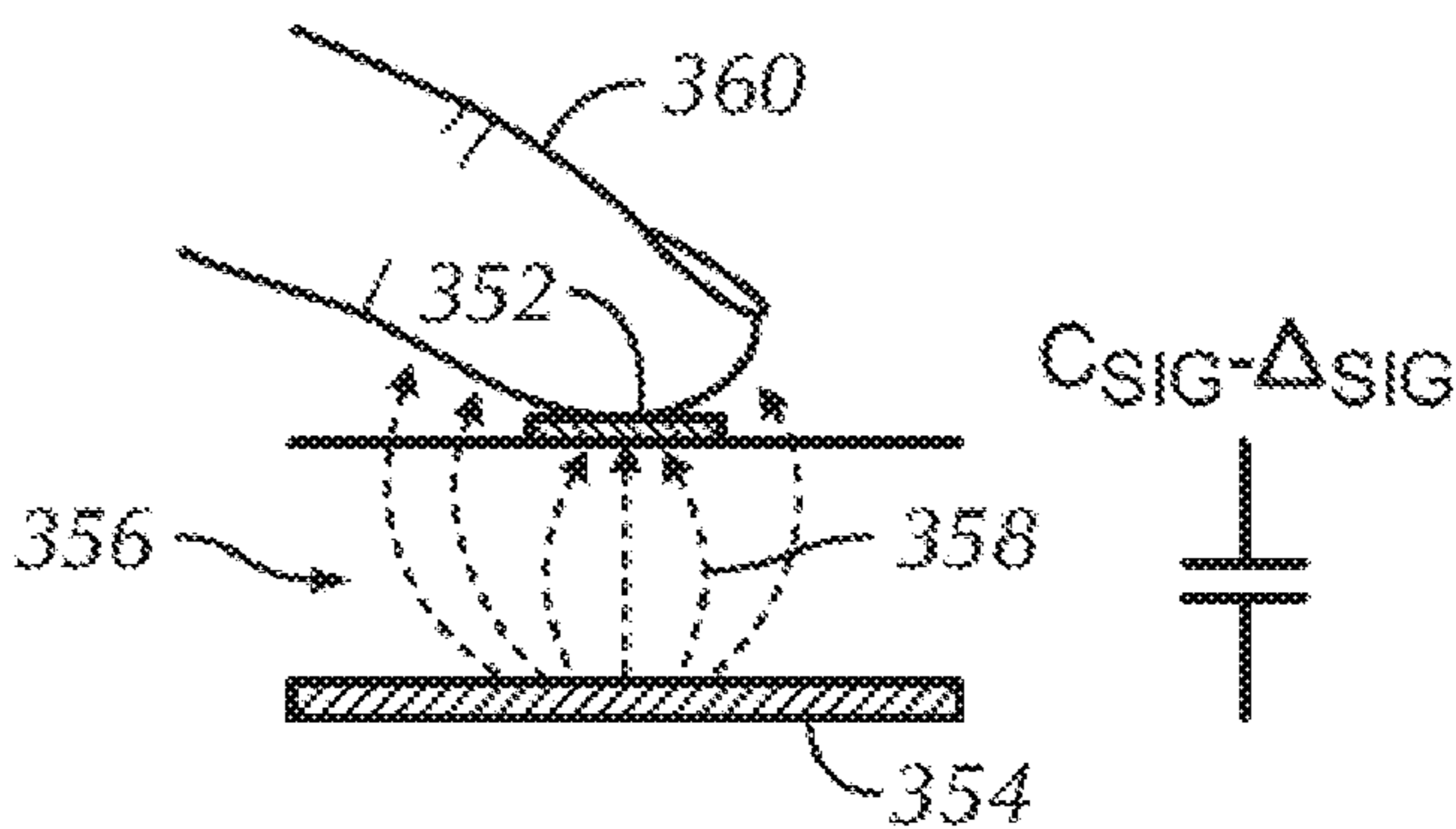

FIG. 9B

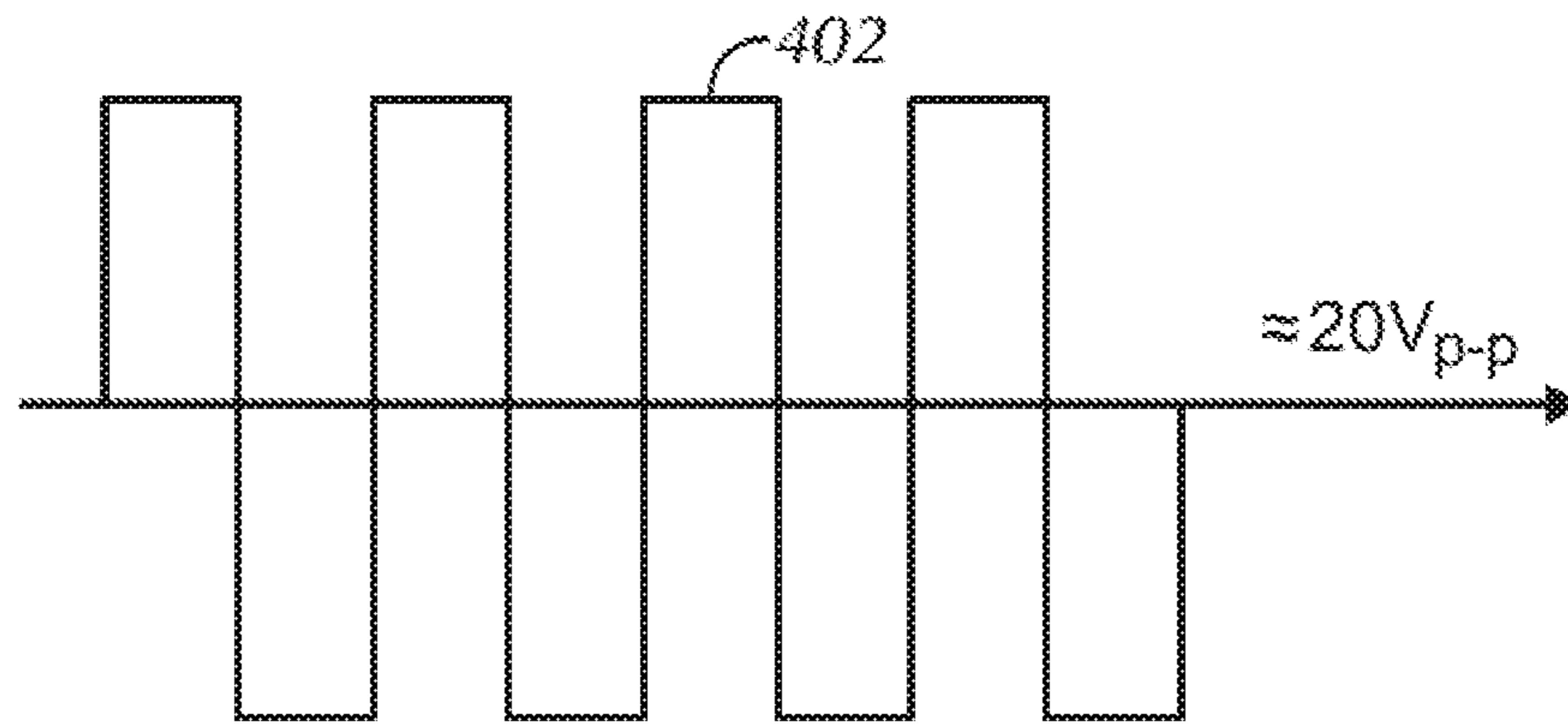

FIG. 10A

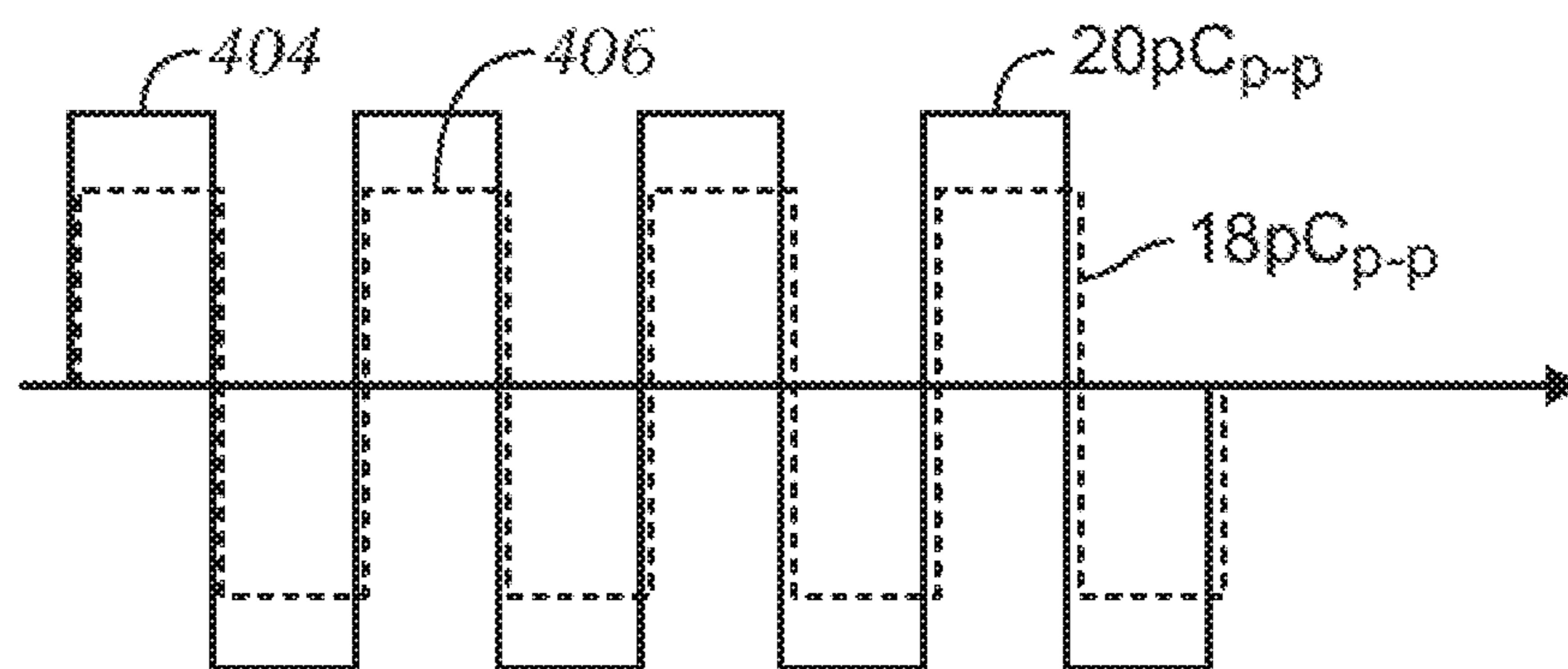

FIG. 10B

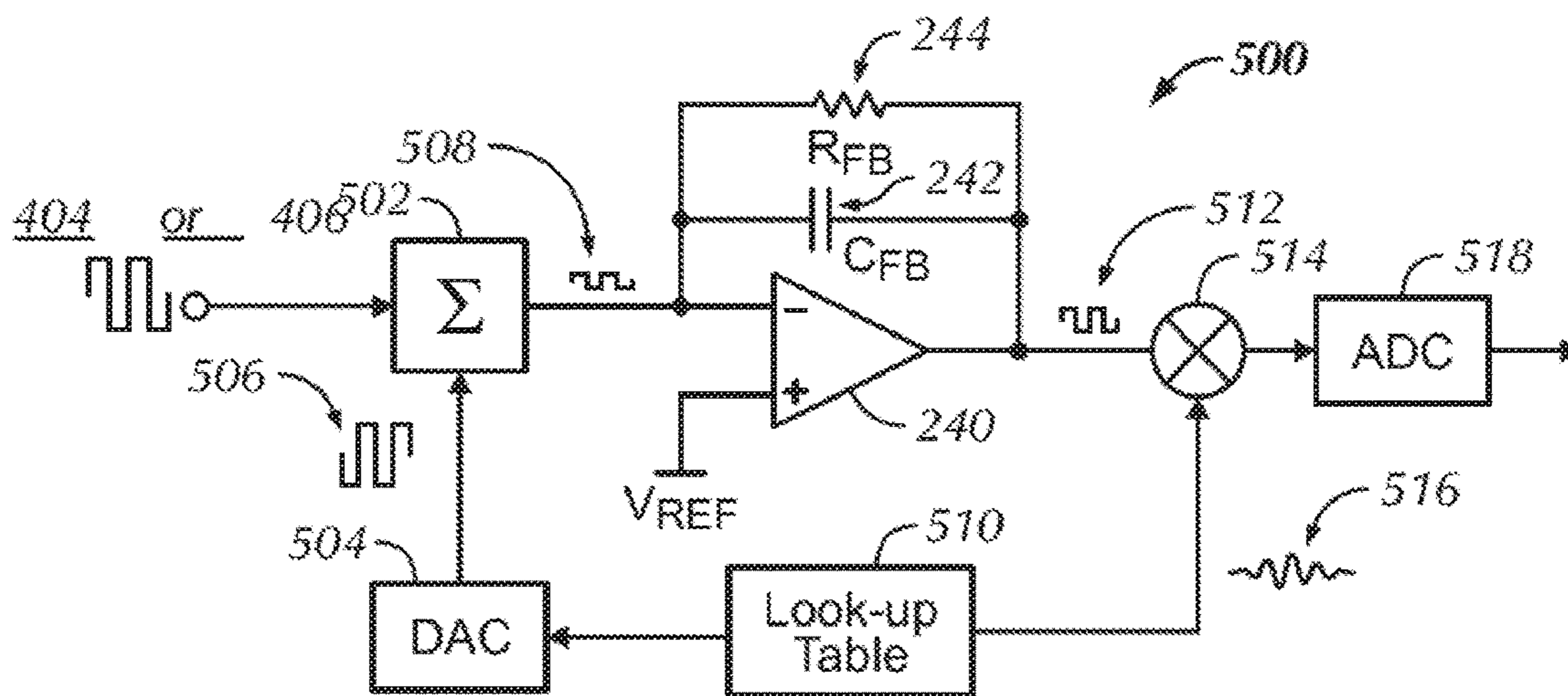

FIG. 11

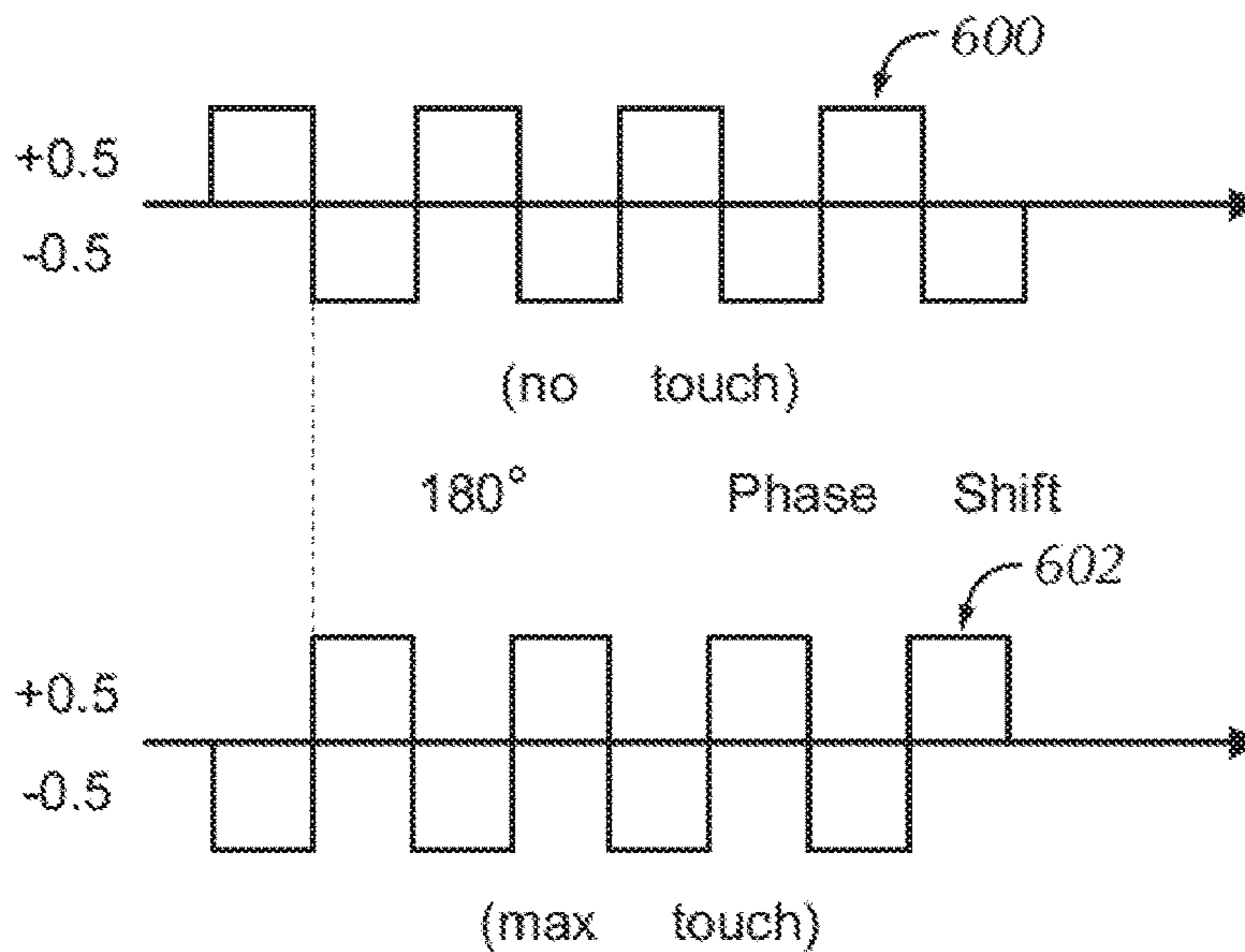

FIG. 12

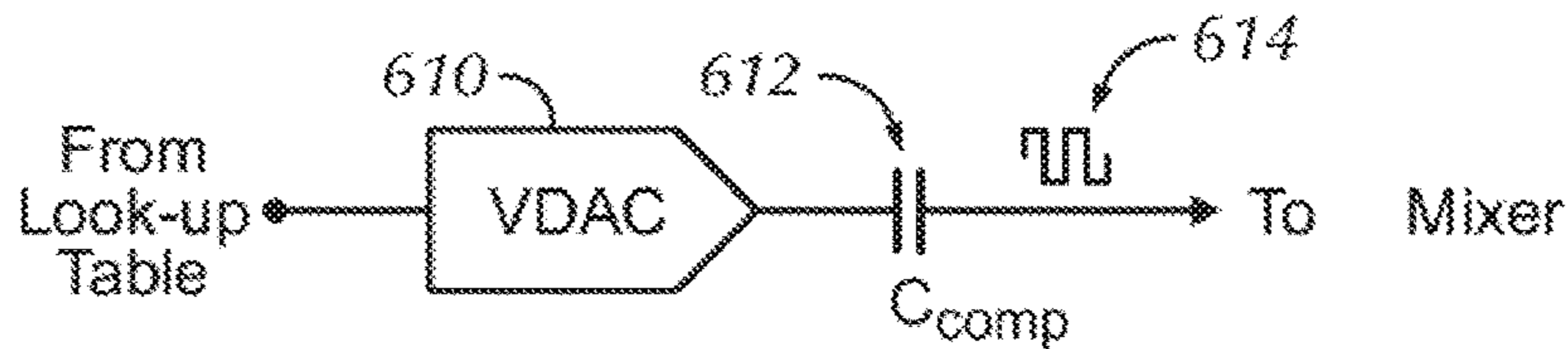

FIG. 13A

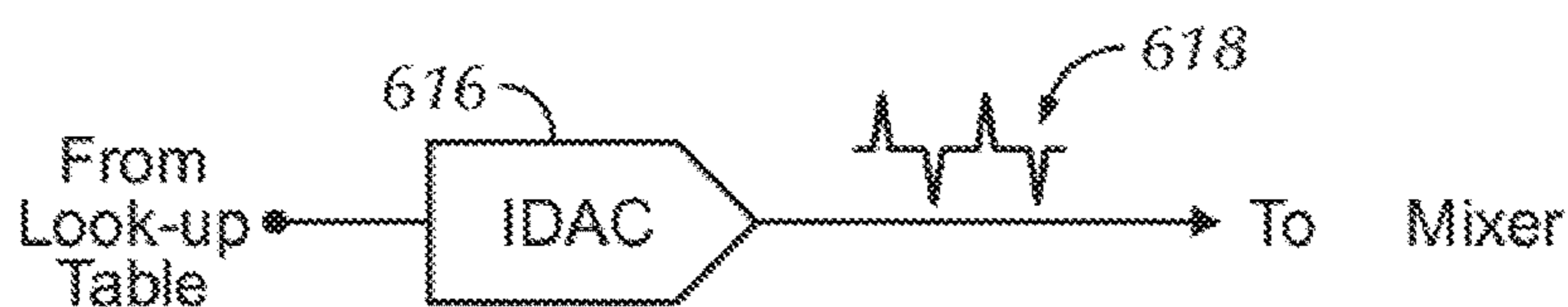

FIG. 13B

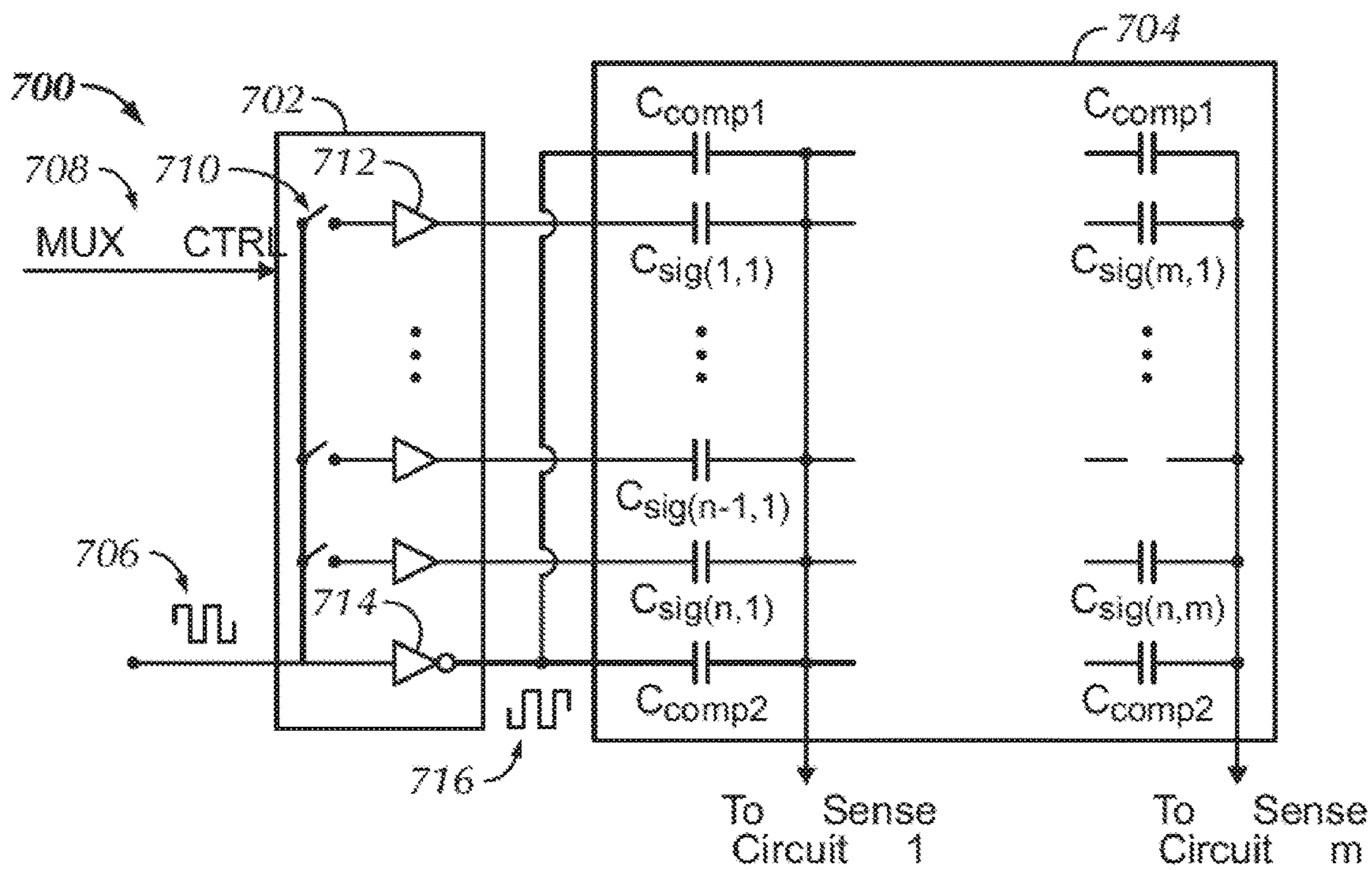

FIG. 14

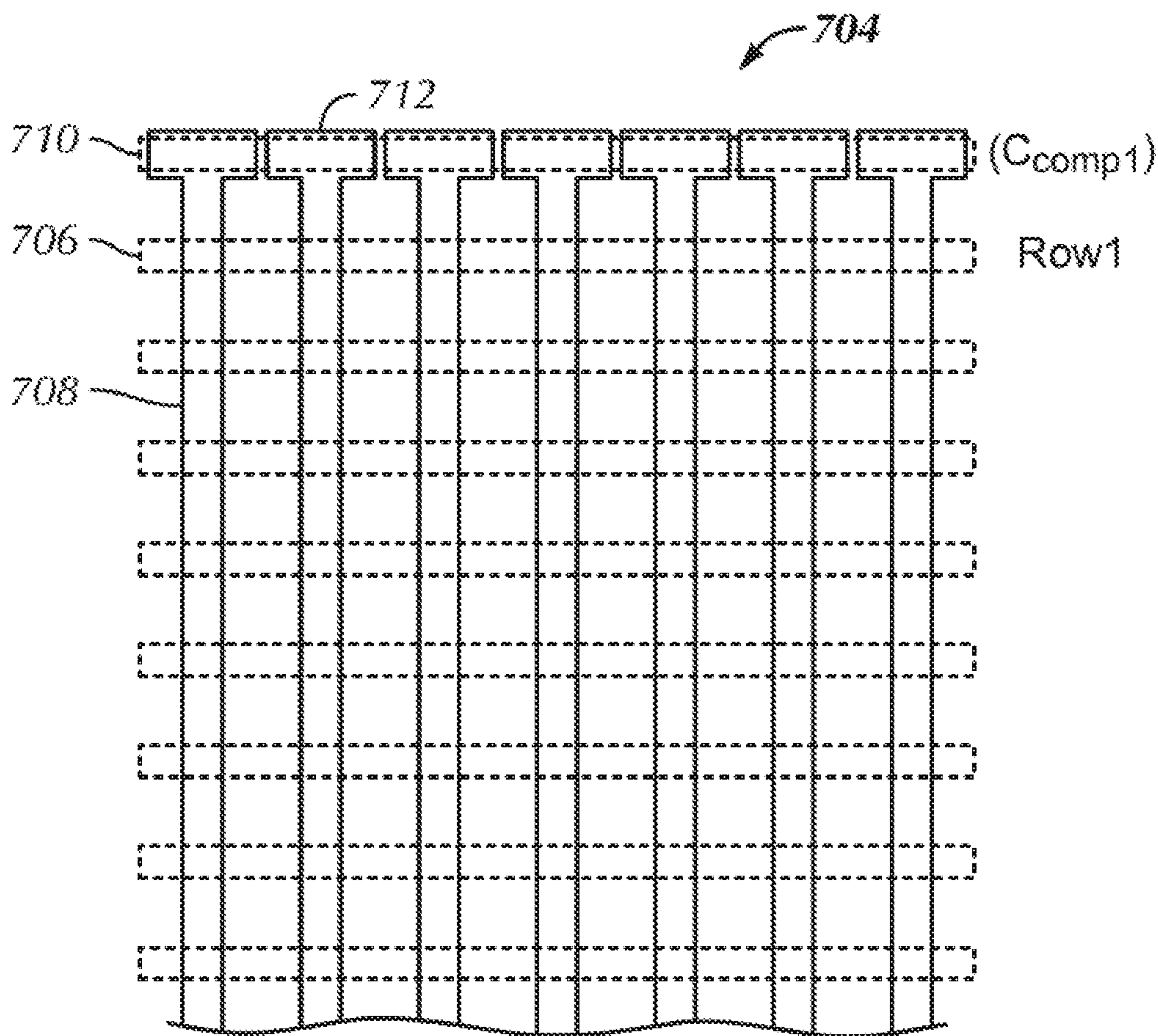

FIG. 15

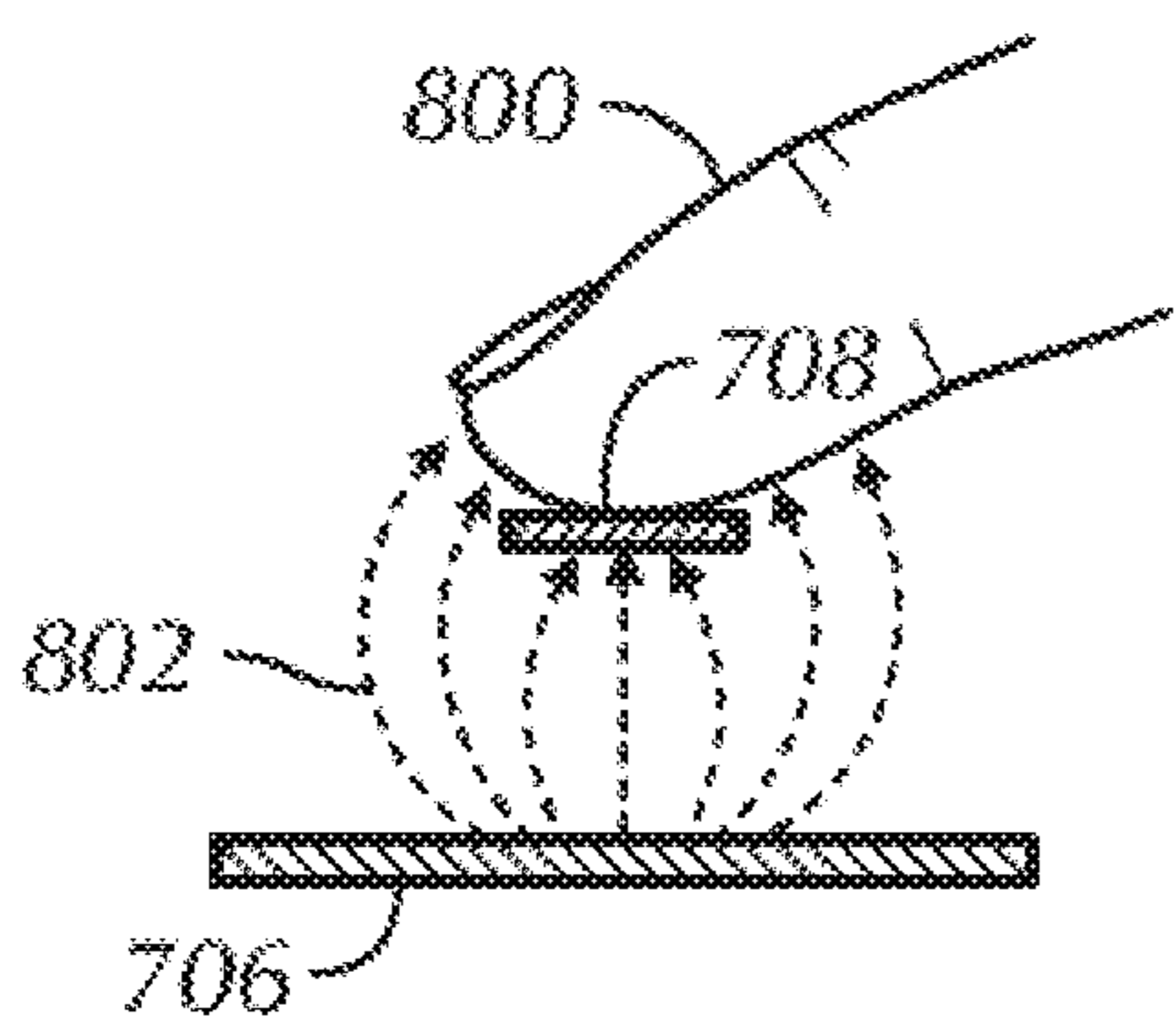

FIG. 16A

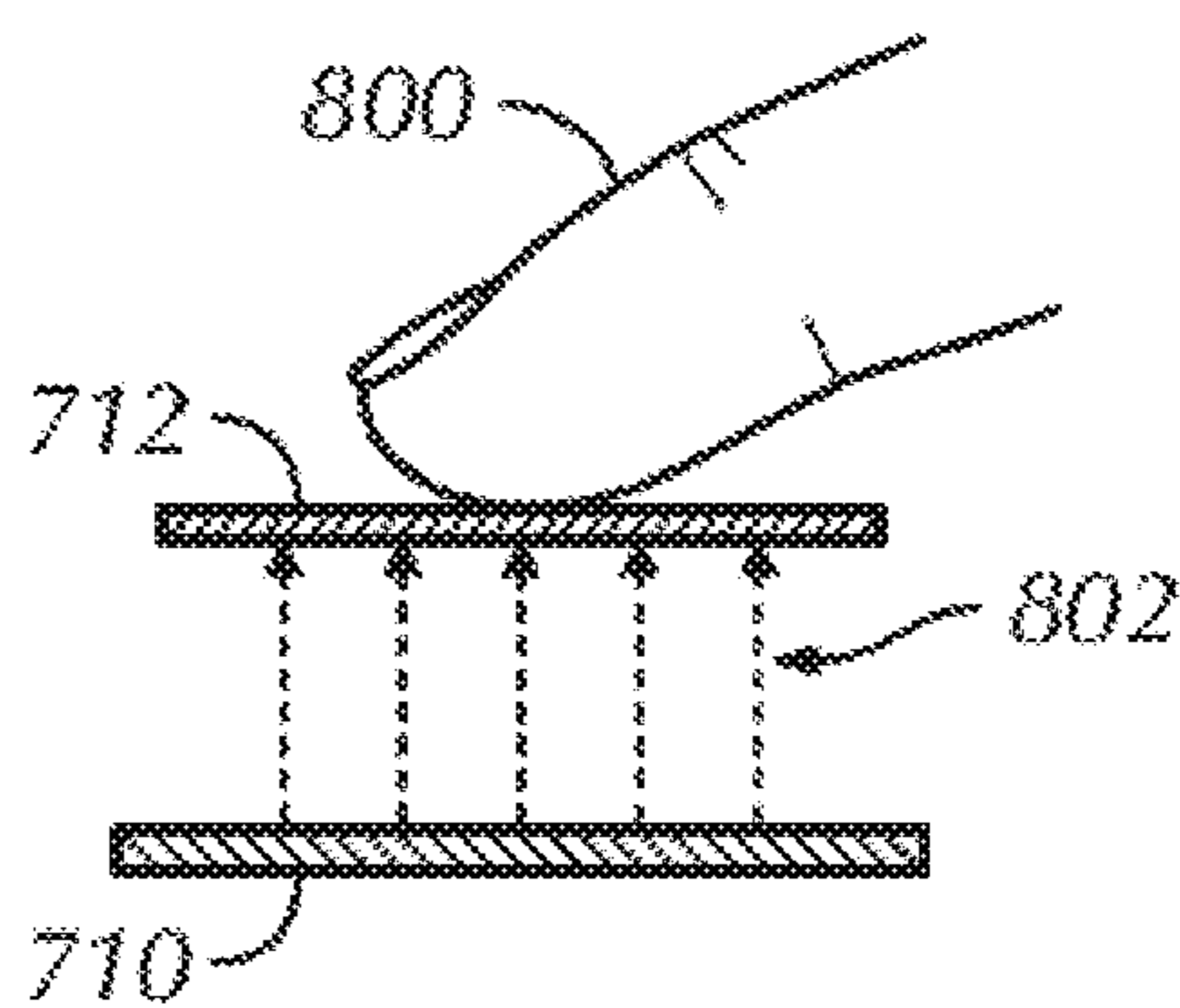

FIG. 16B

1

FRONT-END SIGNAL COMPENSATION

CROSS-REFERENCE TO RELATED
APPLICATIONS

This application is a continuation of U.S. patent application Ser. No. 14/042,462, filed Sep. 30, 2013, and published on Jan. 30, 2014 as Publication No. 2014-0028621; which is a continuation of U.S. patent application Ser. No. 13/284,732, filed Oct. 28, 2011, and issued on Oct. 8, 2013 as U.S. Pat. No. 8,553,004; which is a continuation of U.S. patent application Ser. No. 11/650,043, filed Jan. 3, 2007, and issued on Nov. 1, 2011 as U.S. Pat. No. 8,049,732; the entire contents of which are incorporated herein by reference in their entirety for all purposes.

FIELD OF THE INVENTION

This relates generally to electronic devices (e.g., a touch screen) capable of generating a dynamic output signal, and more particularly, to a method and system of compensating for undesired portions (e.g., a static portion) of the output signal.

BACKGROUND OF THE INVENTION

One example of an electronic device that generates dynamic output signals is a user input device for performing operations in a computer system. Such input devices generate output signals based on user operation of the device or user data or commands entered into the device. The operations generally correspond to moving a cursor and/or making selections on a display screen. By way of example, the input devices may include buttons or keys, mice, trackballs, touch pads, joy sticks, touch screens and the like. Touch pads and touch screens (collectively “touch surfaces”) are becoming increasingly popular because of their ease and versatility of operation as well as to their declining price. Touch surfaces allow a user to make selections and move a cursor by simply touching the surface, which may be a pad or the display screen, with a finger, stylus, or the like. In general, the touch surface recognizes the touch and position of the touch and the computer system interprets the touch and thereafter performs an action based on the touch.

Touch pads are well-known and ubiquitous today in laptop computers, for example, as a means for moving a cursor on a display screen. Such touch pads typically include a touch-sensitive opaque panel which senses when an object (e.g., finger) is touching portions of the panel surface. Touch screens are also well known in the art. Various types of touch screens are described in applicant’s co-pending patent application Ser. No. 10/840,862, entitled “Multipoint Touchscreen,” filed May 6, 2004, which is hereby incorporated by reference in its entirety. As noted therein, touch screens typically include a touch-sensitive panel, a controller and a software driver. The touch-sensitive panel is generally a clear panel with a touch sensitive surface. The touch-sensitive panel is positioned in front of a display screen so that the touch sensitive surface covers the viewable area of the display screen. The touch-sensitive panel registers touch events and sends these signals to the controller. The controller processes these signals and sends the data to the computer system. The software driver translates the touch events into computer events. There are several types of touch screen technologies including resistive, capacitive, infrared, surface acoustic wave, electromagnetic, near field

2

imaging, etc. Each of these devices has advantages and disadvantages that are taken into account when designing or configuring a touch screen.

In conventional touch surface devices, and other types of input devices, there is typically an operational amplifier that amplifies the output signal of the device. The output signal is a dynamic signal in that it changes between two or more states (e.g., a “touch” or “no touch” condition). In conventional devices, the amplifier may be followed by an output signal compensation circuit that provides a compensation signal to offset an undesired portion (e.g., static portion) of the output signal. The problem with this configuration is that the amplifier amplifies both the dynamic signal of interest as well as the undesired static or offset portion.

Additionally, by compensating the output signal after it has been amplified, conventional compensation methods provide poor utilization of the output dynamic range of the amplifier, which results in poor sensitivity in detecting dynamic changes in the output signal.

Furthermore, in devices wherein the output signal is a charge waveform (e.g., an output signal from a capacitive touch surface), a relatively large feedback capacitor is typically connected between the output of the amplifier and the inverting input of the amplifier in order to accommodate relatively large charge amplitudes at the inverting input of the amplifier. The charge amplitudes should be sufficiently large to provide a sufficiently high signal-to-noise (S/N) ratio. The large feedback capacitors, however, consume a significant amount of integrated circuit (IC) chip “real estate” and hence, add significant costs and size requirements to the IC chips.

SUMMARY OF THE INVENTION

The invention addresses the above and other needs by providing a new method and system for compensating for undesired portions (i.e., “offset portions”) of an output signal. In various embodiments, the invention is utilized in connection with a touch surface device, wherein offset compensation is provided to the output signals of the touch surface device before the output signal is provided to an input of an amplifier. Thus, the amplifier amplifies only a desired (e.g., dynamic) portion of the output signal. When the output signal is compensated in this fashion, changes in magnitude of the output signals due to a touch of the touch surface device, for example, reflect a much larger portion of the dynamic range of the amplifier, thereby providing more sensitivity and dynamic range to the touch surface device.

In one embodiment, the output signal of a touch surface device is summed with a compensation signal prior to being provided to an inverting input of an amplifier. The compensation signal has a desired amplitude, waveform, frequency and phase to provide a desired compensation to the output signal. In one embodiment, the compensation signal is generated by a compensation circuit that includes a look-up table, a digital to analog voltage converter (VDAC) and a compensation capacitor C_{COMP} for converting the output of the VDAC into a charge waveform that is used to compensate a charge waveform output of the touch surface device. The look-up table stores digital codes that are provided to the VDAC to generate the desired compensation signal.

In another embodiment, a charge compensation circuit includes a look-up table and a digital-to-analog current converter (IDAC). The look-up table stores digital codes that are provided to the IDAC to generate a desired current

waveform that when viewed in the charge domain corresponds to a desired charge waveform to compensate a charge waveform output signal.

In a further embodiment, a compensation signal is generated by one or more capacitive nodes on a touch surface device that are insensitive to touch. A compensation drive signal, provided to one or more touch-insensitive nodes, is substantially 180 degrees out of phase with the drive signal provided to the touch-sensitive nodes of the touch surface device. The touch-insensitive nodes provide a compensation signal that is substantially 180 degrees out of phase with respect to an output signal generated by a touch sensitive node such that when summed together, a desired portion of the output signal is removed. Additionally, because the compensation signal is being generated by the touch surface device, variations in the output signal from a touch-sensitive node due to variations in processing or external conditions (e.g., temperature, dielectric thickness, etc.) are also exhibited by the compensation signal. Thus, the behavior and/or variations in the compensation signal “track” the behavior and/or variations in the output signals generated by the touch-sensitive portions of the touch surface device.

BRIEF DESCRIPTION OF THE DRAWINGS

FIG. 1 illustrates a perspective view of a touch surface device capable utilizing an improved output signal compensation circuit and method, in accordance with one embodiment of the invention.

FIG. 2 is a block diagram of a computing device or system incorporating a touch surface device, in accordance with one embodiment of the invention.

FIGS. 3A and 3B illustrate two possible arrangements of drive and sense electrodes in a touch screen, in accordance with various embodiments of the invention.

FIG. 4 illustrates a top view of transparent multipoint touch screen, in accordance with one embodiment of the present invention.

FIG. 5 is a partial front elevation view, in cross section of a display arrangement, in accordance with one embodiment of the present invention.

FIG. 6 is a simplified diagram of a mutual capacitance circuit, in accordance with one embodiment of the present invention.

FIG. 7 is a diagram of a charge amplifier, in accordance with one embodiment of the present invention.

FIG. 8 is a block diagram of a touch surface device and controller system, in accordance with one embodiment of the present invention.

FIGS. 9A and 9B illustrate perspective side views of an exemplary capacitive sensing nodes (a.k.a., pixels) in “no touch” and “touch” states, respectively, in accordance with one embodiment of the present invention.

FIG. 10A illustrates an exemplary drive signal waveform applied to a selected drive (e.g., row) electrode of a touch surface panel, in accordance with one embodiment of the present invention.

FIG. 10B illustrates exemplary charge output waveforms (“touch” and “no touch”) generated by a sense (e.g., column) electrode of a touch surface panel, in accordance with one embodiment of the present invention.

FIG. 11 illustrates an exemplary analog sensing circuit or channel with front-end compensation, in accordance with one embodiment of the present invention.

FIG. 12 illustrates exemplary compensated signal waveforms representing a “no touch” and “max touch” state, respectively, in accordance with one embodiment of the present invention.

FIG. 13A illustrates an exemplary compensation signal generator circuit, in accordance with one embodiment of the present invention.

FIG. 13B illustrates another exemplary compensation signal generator circuit, in accordance with another embodiment of the present invention.

FIG. 14 illustrates a touch surface device and its drive circuitry, wherein portions of the touch surface device are utilized to generate a compensation signal, in accordance with one embodiment of the present invention.

FIG. 15 illustrates a top view of an exemplary touch surface panel wherein a top row of the touch surface panel is utilized to generate a compensation signal, in accordance with one embodiment of the invention.

FIGS. 16A and 16B illustrate a touch-sensitive capacitive sensing node and a touch-insensitive node that is utilized to generate at least a portion of a compensation signal, in accordance one embodiment of the invention.

DETAILED DESCRIPTION OF THE PREFERRED EMBODIMENT

In the following description of preferred embodiments, reference is made to the accompanying drawings which form a part hereof, and in which it is shown by way of illustration specific embodiments in which the invention may be practiced. It is to be understood that other embodiments may be utilized and structural changes may be made without departing from the scope of the present invention. Furthermore, although embodiments of the present invention are described herein in terms of devices and applications compatible with computer systems and devices manufactured by Apple Computer, Inc. of Cupertino, Calif., such embodiments are illustrative only and should not be considered limiting in any respect.

FIG. 1 is a perspective view of a touch screen display arrangement 30, which includes a display 34 and a transparent touch screen 36 positioned in front of display 34. Display 34 may be configured to display a graphical user interface (GUI) including perhaps a pointer or cursor as well as other information to the user. Transparent touch screen 36 is an input device that is sensitive to a user’s touch, allowing a user to interact with the graphical user interface on display 34. In general, touch screen 36 recognizes touch events on surface 38 of touch screen 36 and thereafter outputs this information to a host device. The host device may, for example, correspond to a computer such as a desktop, laptop, handheld or tablet computer. The host device interprets the touch event and thereafter performs an action based on the touch event.

In one embodiment, touch screen 36 is configured to recognize multiple touch events that occur simultaneously at different locations on touch sensitive surface 38. That is, touch screen 36 allows for multiple contact points T1-T4 to be tracked simultaneously. Touch screen 36 generates separate tracking signals S1-S4 for each touch point T1-T4 that occurs on the surface of touch screen 36 at the same time. In one embodiment, the number of recognizable touches may be about fifteen which allows for a user’s ten fingers and two palms to be tracked along with three other contacts. The multiple touch events can be used separately or together to perform singular or multiple actions in the host device. Numerous examples of multiple touch events used to control

5

a host device are disclosed in U.S. Pat. Nos. 6,323,846; 6,888,536; 6,677,932; 6,570,557, and co-pending U.S. patent application Ser. Nos. 11/015,434; 10/903,964; 11/048,264; 11/038,590; 11/228,758; 11/228,700; 11/228,737; 11/367,749, each of which is hereby incorporated by reference in its entirety.

FIG. 2 is a block diagram of a computer system 50, employing a multi-touch touch screen. Computer system 50 may be, for example, a personal computer system such as a desktop, laptop, tablet, or handheld computer. The computer system could also be a public computer system such as an information kiosk, automated teller machine (ATM), point of sale machine (POS), industrial machine, gaming machine, arcade machine, vending machine, airline e-ticket terminal, restaurant reservation terminal, customer service station, library terminal, learning device, mobile telephone, audio/video player, etc.

Computer system 50 includes a processor 56 configured to execute instructions and to carry out operations associated with the computer system 50. Computer code and data required by processor 56 are generally stored in storage block 58, which is operatively coupled to processor 56. Storage block 58 may include read-only memory (ROM) 60, random access memory (RAM) 62, hard disk drive 64, and/or removable storage media such as CD-ROM, PC-card, floppy disks, and magnetic tapes. Any of these storage devices may also be accessed over a network. Computer system 50 also includes a display device 68 that is operatively coupled to the processor 56. Display device 68 may be any of a variety of display types including liquid crystal displays (e.g., active matrix, passive matrix, etc.), cathode ray tubes (CRT), plasma displays, etc. Computer system 50 also includes touch screen 70, which is operatively coupled to the processor 56 by I/O controller 66 and touch screen controller 76. (The I/O controller 66 may be integrated with the processor 56, or it may be a separate component.) In any case, touch screen 70 is a transparent panel that is positioned in front of the display device 68, and may be integrated with the display device 68 or it may be a separate component. Touch screen 70 is configured to receive input from a user's touch and to send this information to the processor 56. In most cases, touch screen 70 recognizes touches and the position and magnitude of touches on its surface.

The host processor 561 receives outputs from the touch screen controller 76 and performs actions based on the outputs. Such actions may include, but are not limited to, moving an object such as a cursor or pointer, scrolling or panning, adjusting control settings, opening a file or document, viewing a menu, making a selection, executing instructions, operating a peripheral device connected to the host device, answering a telephone call, placing a telephone call, terminating a telephone call, changing the volume or audio settings, storing information related to telephone communications such as addresses, frequently dialed numbers, received calls, missed calls, logging onto a computer or a computer network, permitting authorized individuals access to restricted areas of the computer or computer network, loading a user profile associated with a user's preferred arrangement of the computer desktop, permitting access to web content, launching a particular program, encrypting or decoding a message, and/or the like. The host processor 76 may also perform additional functions that may not be related to multi-touch (MT) panel processing, and may be coupled to program storage 58 and the display device 68 such as an LCD display for providing a user interface (UI) to a user of the device.

6

In one embodiment, the touch screen panel 70 can be implemented as a mutual capacitance device constructed as described below with reference to FIGS. 3A and 3B. In this embodiment, the touch screen panel 70 is comprised of a two-layered electrode structure, with driving lines or electrodes on one layer and sensing lines or electrodes on the other. In either case, the layers are separated by a dielectric material (not shown). In the Cartesian arrangement of FIG. 3A, one layer is comprised of N horizontal, preferably equally spaced row electrodes 81, while the other layer is comprised of M vertical, preferably equally spaced column electrodes 82. In a polar arrangement, illustrated in FIG. 3B, the sensing lines may be concentric circles and the driving lines may be radially extending lines (or vice versa). As will be appreciated by those skilled in the art, other configurations based on a variety of coordinate systems are also possible. Additionally, it is understood that the invention is not necessarily limited to touch surface devices utilizing mutual capacitance sensing nodes. The invention may be implemented within other types of touch surface devices such as "self capacitance" devices, for example.

Each intersection 83 represents a pixel and has a characteristic mutual capacitance, C_{SIG} . A grounded object (such as a finger) that approaches a pixel 83 from a finite distance shunts the electric field between the row and column intersection, causing a decrease in the mutual capacitance C_{SIG} at that location. In the case of a typical sensor panel, the typical signal capacitance C_{SIG} is about 1.0 picofarads (pF) and the change (ΔC_{SIG}) induced by a finger touching a pixel, is about 0.10 pF. These capacitance values are exemplary only and should not in any way limit the scope of the present invention.

The electrode material may vary depending on the application. In touch screen applications, the electrode material may be ITO (Indium Tin Oxide) on a glass substrate. In a touch tablet, which need not be transparent, copper on an FR4 substrate may be used. The number of sensing points 83 may also be widely varied. In touch screen applications, the number of sensing points 83 generally depends on the desired sensitivity as well as the desired transparency of the touch screen 70. More nodes or sensing points generally increases sensitivity, but reduces transparency (and vice versa).

During operation, each row electrode (i.e., a drive electrode) is sequentially charged by driving it with a predetermined voltage waveform (discussed in greater detail below). The charge capacitively couples to the column electrodes (i.e., sense electrodes) at the intersections between the drive electrode and the sense electrodes. In alternative embodiments the column electrodes can be configured as the drive electrodes and the row electrodes can be configured as the sense electrodes. The capacitance of each intersection 83 is measured to determine the positions of multiple objects when they touch the touch surface. Sensing circuitry monitors the charge transferred and time required to detect changes in capacitance that occur at each node. The positions where changes occur and the magnitude of those changes are used to identify and quantify the multiple touch events.

FIG. 4 is a top view of a transparent multipoint touch screen 150, in accordance with one embodiment of the present invention. As shown, the touch screen 150 includes a two layer grid of spatially separated lines or wires 152. In most cases, the lines 152 on each layer are parallel one another. Furthermore, although in different planes, the lines 152 on the different layers are configured to intersect or cross in order to produce capacitive sensing nodes 154

(a.k.a., “pixels”), which each represent different coordinates in the plane of the touch screen **150**. The nodes **154** are configured to receive capacitive input from an object touching the touch screen **150** in the vicinity of the node **154**. When an object (e.g., a finger tip) is proximate the node **154**, the object steals charge thereby affecting the capacitance at the node **154**. It has been found that as a finger is pressed more firmly against the touch screen surface **150**, the surface area of the finger touching the touch screen **150** increases and a greater amount of charge is diverted away from the underlying sensing node(s) **154**.

The lines **152** on different layers serve two different functions. One set of lines **152A** drives a current there-through while the second set of lines **152B** senses the capacitance coupling at each of the nodes **154**. In most cases, the top layer provides the driving lines **152A** while the bottom layer provides the sensing lines **152B**. The driving lines **152A** are connected to a voltage source (not shown) that separately drives the current through each of the driving lines **152A**. That is, the stimulus is only happening over one line while all the other lines are grounded. They may be driven similarly to a raster scan. Each sensing line **152B** is connected to a capacitive sensing circuit (not shown) that senses a charge and, hence, capacitance level for the sensing line **152B**.

When driven, the charge on the driving line **152A** capacitively couples to the intersecting sensing lines **152B** through the nodes **154** and the capacitive sensing circuits sense their corresponding sensing lines **152B** in parallel. Thereafter, the next driving line **152A** is driven, and the charge on the next driving line **152A** capacitively couples to the intersecting sensing lines **152B** through the nodes **154** and the capacitive sensing circuits sense all of the sensing lines **152B** in parallel. This happens sequentially until all the lines **152A** have been driven. Once all the lines **152A** have been driven, the sequence starts over (continuously repeats). As explained in further detail below, in one embodiment, the capacitive sensing circuits are fabricated on an application specific integrated circuit (ASIC), which converts analog capacitive signals to digital data and thereafter transmits the digital data over a serial bus to a host controller or micro-processor for processing.

The lines **152** are generally disposed on one or more optical transmissive members **156** formed from a clear material such as glass or plastic. By way of example, the lines **152** may be placed on opposing sides of the same member **156** or they may be placed on different members **156**. The lines **152** may be placed on the member **156** using any suitable patterning technique including for example, deposition, etching, printing and the like. Furthermore, the lines **152** can be made from any suitable transparent conductive material. By way of example, the lines may be formed from indium tin oxide (ITO). The driving lines **152A** may be coupled to the voltage source through a flex circuit **158A**, and the sensing lines **152B** may be coupled to the sensing circuits via a flex circuit **158B**. The sensor ICs may be attached to a printed circuit board (PCB).

The distribution of the lines **152** may be widely varied. For example, the lines **152** may be positioned almost anywhere in the plane of the touch screen **150**. The lines **152** may be positioned randomly or in a particular pattern about the touch screen **150**. With regards to the later, the position of the lines **152** may depend on the coordinate system used. For example, the lines **152** may be placed in rows and columns for Cartesian coordinates or concentrically and radially for polar coordinates. When using rows and col-

umns, the rows and columns may be placed at various angles relative to one another. For example, they may be vertical, horizontal or diagonal.

FIG. **5** is a partial front elevation view, in cross section of an exemplary display arrangement **170**. The display arrangement **170** includes an LCD display **172** and a touch screen **174** positioned over the LCD display **172**. The touch screen may for example correspond to the touch screen shown in FIG. **4**. The LCD display **172** may correspond to any conventional LCD display known in the art. Although not shown, the LCD display **172** typically includes various layers including a fluorescent panel, polarizing filters, a layer of liquid crystal cells, a color filter and the like.

The touch screen **174** includes a transparent sensing layer **176** that is positioned over a first glass member **178**. The sensing layer **176** includes a plurality of sensor lines **177** positioned in columns (which extend in and out of the page). The first glass member **178** may be a portion of the LCD display **172** or it may be a portion of the touch screen **174**. For example, it may be the front glass of the LCD display **172** or it may be the bottom glass of the touch screen **174**. The sensor layer **176** is typically disposed on the glass member **178** using suitable transparent conductive materials and patterning techniques. In some cases, it may be desirable to coat the sensor layer **176** with material of similar refractive index to improve the visual appearance, i.e., make it more uniform.

The touch screen **174** also includes a transparent driving layer **180** that is positioned over a second glass member **182**. The second glass member **182** is positioned over the first glass member **178**. The sensing layer **176** is therefore sandwiched between the first and second glass members **178** and **182**. The second glass member **182** provides an insulating layer between the driving and sensing layers **176** and **180**. The driving layer **180** includes a plurality of driving lines **181** positioned in rows (extend to the right and left of the page). The driving lines **181** are configured to intersect or cross the sensing lines **177** positioned in columns in order to form a plurality of capacitive coupling nodes **182**. Like the sensing layer **176**, the driving layer **180** is disposed on the glass member **182** using suitable materials and patterning techniques. Furthermore, in some cases, it may be necessary to coat the driving layer **180** with material of similar refractive index to improve the visual appearance. Although the sensing layer is typically patterned on the first glass member, it should be noted that in some cases it may be alternatively or additionally patterned on the second glass member.

The touch screen **174** also includes a protective cover sheet **190** disposed over the driving layer **180**. The driving layer **180** is therefore sandwiched between the second glass member **182** and the protective cover sheet **190**. The protective cover sheet **190** serves to protect the under layers and provide a surface for allowing an object to slide thereon. The protective cover sheet **190** also provides an insulating layer between the object and the driving layer **180**. The protective cover sheet is suitably thin to allow for sufficient coupling. The protective cover sheet **190** may be formed from any suitable clear material such as glass and plastic. In addition, the protective cover sheet **190** may be treated with coatings to reduce friction or sticking when touching and reduce glare when viewing the underlying LCD display **172**. By way of example, a low friction/anti reflective coating may be applied over the cover sheet **190**. Although the line layer is typically patterned on a glass member, it should be noted that in some cases it may be alternatively or additionally patterned on the protective cover sheet.

The touch screen 174 also includes various bonding layers 192. The bonding layers 192 bond the glass members 178 and 182 as well as the protective cover sheet 190 together to form the laminated structure and to provide rigidity and stiffness to the laminated structure. In essence, the bonding layers 192 help to produce a monolithic sheet that is stronger than each of the individual layers taken alone. In most cases, the first and second glass members 178 and 182 as well as the second glass member and the protective sheet 182 and 190 are laminated together using a bonding agent such as glue. The compliant nature of the glue may be used to absorb geometric variations so as to form a singular composite structure with an overall geometry that is desirable. In some cases, the bonding agent includes an index matching material to improve the visual appearance of the touch screen 170.

FIG. 6 is a simplified diagram of a mutual capacitance circuit 220, in accordance with one embodiment of the present invention. The mutual capacitance circuit 220 includes a driving line 222 and a sensing line 224 that are spatially separated by a capacitive coupling node 226. The driving line 222 is electrically coupled to a voltage source 228, and the sensing line 224 is electrically coupled to a capacitive sensing circuit 230. The driving line 222 is configured to carry a current to the capacitive coupling node 226, and the sensing line 224 is configured to carry a current to the capacitive sensing circuit 230. When no object is present, the capacitive coupling at the node 226 stays fairly constant. When an object 232 such as a finger is placed proximate the node 226, the capacitive coupling through the node 226 changes. The object 232 effectively shunts some of the electromagnetic field away so that the charge formed across the node 226 decreases. The change in capacitive coupling changes the current that is carried by the sensing lines 224. The capacitive sensing circuit 230 notes the current change and the position of the node 226 where the current change occurred and reports this information in a raw or in some processed form to a host controller or microprocessor. Such sensing occurs for each node at a rapid scan rate so that from the perspective of a user it appears that all nodes are sensed simultaneously.

In one embodiment, the capacitive sensing circuit 230 includes an input filter 236 for eliminating parasitic or stray capacitance 237, which may for example be created by the large surface area of the row and column lines relative to the other lines and the system enclosure at ground potential. Generally speaking, the filter rejects stray capacitance effects so that a clean representation of the charge transferred across the node 226 is outputted. That is, the filter 236 produces an output that is not dependent on the parasitic or stray capacitance, but rather on the capacitance at the node 226. As a result, a more accurate output is produced.

FIG. 7 is a diagram of a charge amplifier 240 that may be used as the filter 236, in accordance with one embodiment of the present invention. As shown, the amplifier includes a non inverting input that is held at a constant voltage (e.g., a reference voltage or ground), and an inverting input that is coupled to the node 226. The output of the amplifier 240 is coupled back to the inverting input through a feedback capacitor (C_{FB}) 242. As is known in the art, in this configuration, the amplifier 240 and C_{FB} 242 eliminate stray capacitance that may otherwise effect the measurement of capacitance or change in capacitance (ΔC_{SIG}) at the capacitive sensing node 226. Because of the characteristics of the amplifier 240, any charge that appears across C_{STRAY} will be equal to the charge at the output of the amplifier and, therefore, no matter how much stray capacitance C_{STRAY} is

added to the inverting input, the net charge across C_{SIG} will always be zero. In one embodiment, the inverting amplifier 240 in combination with the C_{FB} 242 perform the following tasks: (1) charge to voltage conversion, (2) charge amplification, (3) rejection of stray capacitance present at the column electrode, (4) anti aliasing, and (5) gain equalization at different frequencies. Charge to voltage conversion is performed by the feedback capacitor C_{FB} in the feedback path of the amplifier 240.

In one embodiment, the functions of driving each row electrode and sensing the charge transfer on each corresponding column electrode are performed by a multipoint touch screen controller system 300, as shown in FIG. 8. The controller system 100 includes a touch surface device 301 (e.g., a touch screen or touch pad), an application specific integrated circuit (ASIC) chip 305 for receiving output (e.g., touch data) from the touch surface 301, a microprocessor 307 for receiving and processing digital data from the ASIC 305, a level shifter or voltage multiplier 310 for generating drive signals of a desired amplitude, and a decoder 311 for decoding timing signals from the microprocessor and applying the drive signal to an appropriate row electrode.

In one embodiment, the ASIC 305 receives analog signals (e.g., voltage waveforms) from each column electrode 82 (FIG. 3a) of the touch surface device 301 indicating a touch or no-touch condition at a respective capacitive sensing node 83 corresponding to an intersection of the column electrode 82 and a selected, driven row electrode 81 of the touch surface device 301. The ASIC 305 converts the analog signals received from the node 83 of the touch surface 301 into digital signals which are then received and processed by the microprocessor 307 in order to sense touch and/or multi-touch states. In one embodiment, the ASIC 305 contains a plurality of inverting amplifier 240 and feedback capacitor 242 circuits, similar to that shown in FIG. 7, each coupled to respective column electrodes of the touch surface device 301.

The ASIC 305 further generates all the drive waveforms necessary to scan the sensor panel and provides those waveforms to the level shifter 310, which amplifies the drive waveforms. In one embodiment, the microprocessor 307 sends a clock signal 321 to set the timing of the ASIC 305, which in turn generates the appropriate timing waveforms 322 to create the row stimuli to the touch surface device 301. Decoder 311 decodes the timing signals to drive each row of the touch surface 301 in sequence. Level shifter 310 converts the timing signals 322 from the signaling level (e.g., 3.3 V_{p-p}) to the level used to drive the touch surface device 301 (e.g., 18V_{p-p}).

In one embodiment, it is desirable to drive the panel at multiple different frequencies for noise rejection purposes. Noise that exists at a particular drive frequency may not, and likely will not exist at the other frequencies. In one embodiment, each sensor panel row is stimulated with three bursts of twelve square wave cycles (50% duty-cycle, 18V amplitude), while the remaining rows are kept at ground. For better noise rejection, the frequency of each burst is different. Exemplary burst frequencies are 140 kHz, 200 kHz, and 260 Khz. A more detailed discussion of this “frequency hopping” method is provided in a commonly-owned and concurrently pending patent application entitled “Scan Sequence Generator” (U.S. application Ser. No. 11/650, 046), the entirety of which is incorporated by reference herein.

During each burst of pulses, ASIC 305 takes a measurement of the column electrodes. This process is repeated for all remaining rows in the sensor panel. After all rows have

been scanned in a single scan cycle, the measurement results are used to provide one or more images of the touch/no-touch state of the touch surface **301**, each image taken at a different stimulus frequency. The images are stored in a memory (not shown) accessible by the microprocessor **307** and processed to determine a no-touch, touch or multi-touch condition.

FIG. **9A** illustrates a side view of an exemplary sensing node (a.k.a., pixel) **350** in a steady-state (no-touch) condition. The node **350** is located at an intersection of a row electrode **352** and a column electrode **354**, separated by a dielectric **356**. An electric field illustrated by electric field lines **358** between the column **354** and row **352** traces or electrodes create a mutual capacitance, C_{SIG} , between the row and column electrodes when a driving signal or stimulus is applied to the row electrode or trace **352**.

FIG. **9B** is a side view of the exemplary node **350** in a dynamic (touch) condition. A user's finger **360**, which has been placed on or near the node **350**, blocks some of the electric field lines **358** between the row **352** and column **354** electrodes (those fringing fields that exit the dielectric and pass through the air above the row electrode). These electric field lines are shunted to ground through the capacitance inherent in the finger, and as a result, the steady state signal capacitance C_{SIG} is reduced by ΔC_{SIG} . Therefore, the signal capacitance at the node **350** becomes $C_{SIG} - \Delta C_{SIG}$, where C_{SIG} represents the static (no touch) component and ΔC_{SIG} represents the dynamic (touch) component. Note that $C_{SIG} - \Delta C_{SIG}$ may always be nonzero due to the inability of a finger or other object to block all electric fields, especially those electric fields that remain entirely within the dielectric. In addition, it should be understood that as a finger is pushed harder or more completely onto the touch surface, the finger will tend to flatten and increase in surface area, thereby blocking more of the electric fields. Thus, ΔC_{SIG} may be variable and representative of how completely the finger is pushing down on the panel (i.e., a range from "no-touch" to "full-touch").

FIG. **10A** illustrates an exemplary driving signal waveform **402** that may be provided to a row electrode **81** (FIG. **3A**). In this example, the driving signal is a square wave signal having a peak-to-peak amplitude of approximately $20 V_{p-p}$. Since charge (Q) equals voltage (V) multiplied by capacitance (C), if the mutual capacitance (C_{SIG}) at a sensing node **83** is 1.0 pF, for example, the output at the corresponding column electrode **82** will be a square wave having an amplitude of 20 pico-coulombs peak-to-peak (pC_{p-p}) when viewed in the charge domain, as shown by solid line **404** in FIG. **10B**. When a finger or other object comes in close proximity to the node **83**, its mutual capacitance value will decrease to $C_{SIG} - \Delta C_{SIG}$, as discussed above. If, for example, the decreased capacitance $C_{SIG} - \Delta C_{SIG} = 0.9$ pF, then the output at the column electrode **82** will be a square wave having a peak-to-peak amplitude of $18 pC_{p-p}$, as indicated by the dashed waveform **406** in FIG. **10B** (these figures are not necessarily drawn to scale). Thus, the difference in charge output from a column electrode between a "no-touch" condition and a "touch" condition would be $20 - 18 = 2 pC_{p-p}$ in this example.

FIG. **11** illustrates a capacitive sensing circuit **500** with front-end charge compensation, in accordance with one embodiment of the invention. Depending on whether a touch condition is being sensed at a respective capacitive sensing node, as described above, a charge waveform **404** (no touch) or **406** (touch) will be received at a first input of a signal summing circuit or multiplier **502**. The sensing circuit **500** further includes a digital-analog-converter (DAC) **504**

which provides a compensation waveform signal **506** to a second input of the multiplier **502**. The compensation waveform signal **506** is generated to have substantially the same frequency as the charge waveform **404** or **406** but substantially 180 degrees out of phase with the charge waveform **404** or **406** outputted from the touch surface device **301** (FIG. **8**). The amplitude of the compensation signal **506** may be selected to achieve any desired level of offset and/or amplitude range for the resulting compensated signal **508** outputted by the multiplier **502**. In one embodiment, the peak-to-peak amplitude of the compensation signal **506** is selected to be the average of the amplitudes of waveforms **404** and **406**. For example, if the amplitude of waveform **404** is $20 pC_{p-p}$ and the amplitude of waveform **406** is $18 pC_{p-p}$ (e.g., at full touch), the amplitude of the compensation waveform **506** would be selected to be $19 pC_{p-p}$. Various advantages of selecting the amplitude of the compensation waveform **506** to be the average of the amplitudes of waveforms **404** and **406** are discussed in further detail below.

The capacitive sensing circuit **500** further includes a look-up table **510** that provides a digital signal to the DAC **504**, which the DAC **504** converts into the desired compensation waveform **506**, having a desired amplitude, shape, frequency and phase. Various embodiments of the DAC **504** are described in further detail below. In one embodiment, the look-up table **510** is pre-programmed to provide digital codes to the DAC **504** to generate predetermined compensation waveforms **506** corresponding to each drive signal frequency. A control signal **511** generated by row or channel scan logic circuitry (not shown) within the ASIC **305** controls what outputs will be provided to the DAC **504** and mixer **512** (described below). In various embodiments, the look-up table **510** may be implemented as one or more look-up tables residing in a memory of the ASIC **305**. Thus, in the embodiment illustrated in FIG. **11**, a front-end compensation circuit is provided that includes the summing circuit **502**, the DAC **504** and the look-up table **510**.

The compensated output signal **508** from the summing circuit **502** is provided to an inverting input of the operational amplifier **240**. Since the compensated signal **508** is a charge waveform, the feedback capacitor **242** converts the charge waveform into a voltage waveform according to the equation $Q = C_{FB} V_{out}$ or $V_{out} = Q / C_{FB}$, where Q is the amplitude of the compensated waveform **508** and V_{out} is the amplitude of the resulting voltage waveform **512** at the output of the amplifier **240**. It will be appreciated that since the peak-to-peak amplitude of the compensated waveform **508** (e.g., $0-2 pC_{p-p}$) is significantly smaller than the amplitude of the uncompensated waveforms **404** or **406**, the value of C_{FB} may be significantly reduced (e.g., by a factor of 10-20 times) while maintaining desired voltage ranges (e.g., CMOS levels) for V_{out} **512** at the output of the amplifier **240**. For example, to achieve a dynamic range of 1 volt, peak-to-peak (V_{p-p}) at the output of the amplifier **240**, if the signal at the inverting input of the amplifier is $20 pC_{p-p}$ (uncompensated), then C_{FB} must be equal to 20 pF. In contrast, if the maximum amplitude of the signal at the inverting input of the amplifier **240** is $2 pC_{p-p}$ (compensated), then C_{FB} must only equal 2 pF to provide a dynamic range of $1 V_{p-p}$. This reduction in size of C_{FB} is a significant advantage in terms of chip cost and "real estate" for the ASIC **305** (FIG. **8**), which, in one embodiment, can contain multiple capacitive sensing circuits **500** at its input stage. Capacitors require a relatively large die area in integrated circuits, which add to their costs and limit the number of devices (e.g., transistors)

that can be integrated onto the IC chip. Therefore, it is advantageous to decrease the size of capacitors in IC chips when possible.

As shown in FIG. 11, the output waveform 511 of the amplifier 240 is provided to a first input of a mixer 514. Since the waveform 511 is a square wave, which may create undesirable harmonics, a demodulation waveform 516, which may be a sine wave digitally generated from the look-up table 510, is synchronized to the output signal 511 and provided to a second input of the mixer 514. In one embodiment, the mixer 514 demodulates the output 511 of the charge amplifier by subtracting the demodulation waveform 516 from the output signal 511 to provide better noise rejection. The mixer 514 rejects all frequencies outside its passband, which may be about ± 30 kHz around the frequency of the demodulation waveform 516. This noise rejection may be beneficial in noisy environment with many sources of noise, such as 802.11, Bluetooth, etc. In some embodiments, the mixer 514 may be implemented as a synchronous rectifier that outputs a rectified Gaussian sine wave. The output of the mixer is provided to an analog-to-digital converter (ADC) 518, which converts the analog signals into corresponding digital signals for storage and processing by the microprocessor 307 (FIG. 8).

In one embodiment, the ADC 518 may be a sigma-delta converter, which may sum a number of consecutive digital values and average them to generate a result. However, other types of ADCs (such as a voltage to frequency converter with a subsequent counter stage) could be used. The ADC typically performs two functions: (1) it converts the offset compensated waveform from the mixer 514 to a digital value; and (2) it performs low pass filtering functions, e.g., it averages a rectified signal coming out of the mixer arrangement. The offset compensated, demodulated signal looks like a rectified Gaussian shaped sine wave, whose amplitude is a function of C_{FB} and C_{SIG} . The ADC result returned to the microprocessor 307 is typically the average of that signal.

It is appreciated that the front-end charge compensation provided by the summing circuit 502 also significantly improves utilization of the dynamic range of the amplifier 240. Referring again to FIG. 10B, the uncompensated charge waveforms generated by a capacitive sensing node 83 (FIG. 3) may be in range of 18 pC_{p-p} (max touch) to 20 pC_{p-p} (no touch). If these signals were provided directly to the inverting input of the amplifier 240, and if the feedback capacitor (C_{FB}) is equal to 10 pF, for example, the output of the amplifier will be a voltage waveform in the range of 1.8 V_{p-p} (max touch) to 2.0 V_{p-p} (no touch). Thus, the dynamic range utilized to sense the difference between a no touch condition and max touch condition would be only 0.2 V_{p-p} , which represents a poor utilization of the dynamic range of the amplifier 240.

FIG. 12 illustrates a compensated charge square waveform 600 when the output charge square waveform 404 (FIG. 10B) having an amplitude of 20 pC_{p-p} , which represents a “no touch” state, is compensated with a compensation waveform 506 (FIG. 11) having an amplitude of 19 pC_{p-p} at the same frequency but 180 degrees out of phase with the output waveform 404. The resulting compensated waveform 600 is a charge waveform having an amplitude of 1 pC_{p-p} with a phase that is the same as the original output waveform 404. FIG. 12 further illustrates a compensated charge square waveform 602 when the output charge square waveform 406 having an amplitude of 18 pC_{p-p} , which represents a “max touch” state, is compensated with the compensation waveform 506. The resulting compensated

waveform 602 is a charge waveform having an amplitude of 1 pC_{p-p} with a phase that is the same as the compensation waveform 506 and opposite the phase of the waveform 600.

Thus, with front-end charge compensation, the charge waveform provided to the inverting input of the amplifier 240 swings from $+0.5 \text{ pC}$ to -0.5 pC and its phase shifts 180 degrees as the output levels transition from a “no touch” state to a “max touch” state. If the feedback capacitor (C_{FB}) 242 is equal to 1 pF, for example, the output of the amplifier 240 will mirror the inverting input and will swing from $+0.5 \text{ V}$ to -0.5 V from a “no touch” state to a “max touch” state. Thus, in this example, the utilizing of the dynamic range of the amplifier 240 is increased from 0.2 V_{p-p} to 1.0 V_{p-p} , which is a significant improvement. Additionally, the phase of the amplifier output will shift by 180 degrees at approximately a midpoint (e.g., a “medium touch” state) during the transition from a “no touch” state to a “max touch” state. This phase shift can be utilized to provide additional information concerning the level of pressure being exerted by a touch or a type of touch. As mentioned above, as a finger is pressed more firmly onto a touch surface, it tends to flatten and increase in surface area, thereby stealing more charge from the sensing node and reducing C_{SIG} . Thus, the compensated waveform 600 will decrease in peak-to-peak amplitude from a “no touch” state to a “medium touch” state, at which point the compensated waveform 600 is ideally a flat line having an amplitude of 0 V_{p-p} . As a finger is pressed harder onto the touch surface, the compensated waveform will transition from a “medium touch” state to a “max touch” state and shift 180 degrees in phase. Additionally, its amplitude will gradually increase as the finger is pressed down harder until the compensated waveform reaches the “max touch” state waveform 602, as shown in FIG. 12.

FIG. 13A illustrates an exemplary compensation signal generator 504 (FIG. 11) that includes a digital-to-analog voltage converter (VDAC) 610 and compensation capacitor (C_{COMP}) 612, in accordance with one embodiment of the invention. The VDAC 610 receives digital signals from a look-up table (e.g., look-up table 510 in FIG. 11) and generates a corresponding analog voltage signal (e.g., a square wave) having a desired amplitude, frequency and phase. This analog voltage signal is then provided to C_{COMP} 612, which converts the voltage waveform into a charge waveform 614 for compensating a charge waveform (e.g., 404 or 406) outputted by a touch surface device, for example. This exemplary compensation circuit provides the benefit of increasing the dynamic range of the analog sensing circuit, which includes the amplifier 240 and feedback capacitor (C_{FB}) 242 discussed above. However, one potential drawback to this compensation circuit is the necessity of the compensation capacitor (C_{COMP}) 612. This capacitor will typically be approximately the same size or on the same order of magnitude in size as C_{FB} . Therefore, the cost and chip “real estate” savings achieved by the reduction in size of C_{FB} 242 is offset by the need for C_{COMP} 612.

FIG. 13B illustrates another exemplary compensation signal generator 504 comprising a digital-to-analog current converter (IDAC) 616, in accordance with another embodiment of the invention. In this embodiment, IDAC 616 generates a periodic current waveform 618 having a desired amplitude, frequency and phase based on digital codes received from the look-up table 510 (FIG. 11). Since current represents a change in charge over time (or, in other words, charge is the integral of current over time), the current waveform 618 resembles a square wave when viewed in the charge domain. Thus, the current waveform 618 can be provided directly to the input of the summing circuit 502

(FIG. 11) to compensate the output charge waveform **404** or **406** from the touch surface device. However, because the current waveform **618** is characterized by a plurality of periodically alternating current spikes, it presents potentially difficult timing issues when trying to achieve an accurate 180 degree phase shift between the current waveform **618** and the output charge waveform **404** or **406** from the touch surface device. Thus, the IDAC **616** provides both the benefits of increasing the dynamic range of the analog sensing circuit **500** (FIG. 11) and decreasing IC chip cost and “real estate” requirements due to C_{FB} (since C_{COMP} is not required). However, the IDAC **616** is less tolerant of phase mismatches and can add to the complexity of the timing logic requirements of the sensing circuit **500**. In one embodiment, in order to minimize phase mismatches and the effects of any phase mismatches between a compensation signal and an output signal, the invention utilizes the methods and circuits described in a co-pending and commonly-owned patent application entitled “Minimizing Mismatch During Phase Compensation” (U.S. application Ser. No. 11/650,038), the entirety of which is incorporated by reference herein.

FIG. 14 illustrates a touch surface system **700** that includes a high-voltage level shifter and decoder unit **702** and touch surface panel **704**, in accordance with one embodiment of the invention. In this embodiment, the touch surface panel **704** utilizes two touch-insensitive portions (e.g., top and bottom rows) of the touch surface panel **704** to provide substantially fixed mutual capacitance values C_{COMP1} and C_{COMP2} , respectively. When a 180-degree phase-shifted drive signal is applied to the top and bottom rows, C_{COMP1} and C_{COMP2} generate two compensation signals that, when summed, compensate the output signals provided by the capacitive nodes of a selected touch-sensitive row, as described above. The level shifter/decoder unit **702** performs functions similar to the level shifter **310** and decoder **311** described above with respect to FIG. 8. In this embodiment, however, the functionality of these devices is integrated into a single IC chip **702**. The level shifter/decoder unit **702** receives an input waveform **706** from ASIC **305** (FIG. 8), which may be a series of twelve square wave pulses having a peak-to-peak amplitude of $2 V_{p-p}$, for example. The level shifter/decoder unit **702** then amplifies this signal to $20 V_{p-p}$, for example, and provides this drive signal to a selected row (1-n) based on a timing signal or MUX control signal **708** received from a microprocessor **307** (FIG. 8) or the ASIC **305**.

The level shifter/decoder unit **702** further includes a plurality of selection switches **710**, which close when a corresponding row has been selected to be driven by the amplified drive signal. In one embodiment, the level shifter/decoder unit **702** has an output driver **712** corresponding to each row of the panel **704**. In alternative embodiments multiple rows may be connected to the output of one or more drivers **712** via a multiplexing/demultiplexing circuit arrangement. The level shifter/decoder unit **702** further includes an inverting gate **714** which inverts the incoming drive signal **706** to produce a 180-degree phase-shifted compensation signal that is provided to a top compensation row (C_{COMP1}) and a bottom compensation row (C_{COMP2}) of the touch surface panel **704**.

The touch surface panel **704** includes a plurality of capacitive sensing nodes, $C_{SIG(n, m)}$ arranged in an (n×m) matrix, where n represents the number of touch sensitive row electrodes and m represents the number of column electrodes, which through mutual capacitance, provide output signals indicative of touch or no-touch conditions on the

panel **704**. The panel **704** further includes a top row or strip that is touch-insensitive and provides a substantially fixed capacitance of C_{COMP1} . A bottom strip of the panel is also touch-insensitive and provides a substantially fixed capacitance of C_{COMP2} . As discussed above, the drive signal applied to the top and bottom touch-insensitive rows is 180 degrees out of phase with the drive signal applied to a selected touch-sensitive row. Each column electrode is always connected to the touch-insensitive rows and selectively connected to a touch-sensitive row (1-n) one at a time. Thus, the compensated capacitance seen at the output of each column electrode is effectively $C_{SIG} - (C_{COMP1} + C_{COMP2})$.

In one embodiment, the top and bottom strips of the panel **704** are designed so that the values of C_{COMP1} and C_{COMP2} satisfy the following equation:

$$C_{COMP1} + C_{COMP2} = (2C_{SIG} - \Delta C_{SIG}) / 2.$$

In the above equation, ΔC_{SIG} represents the change in mutual capacitance due to a max touch condition, as discussed above. With this design, the effective compensation signal provided by C_{COMP1} and C_{COMP2} has an amplitude that is equal to the average of the amplitude of the capacitive sensing node outputs when the node is experiencing a “no touch” state (C_{SIG}) and a “max touch” state ($C_{SIG} - \Delta C_{SIG}$). Some of the advantages of designing the amplitude of the compensation signal to be equal to the average of the output values corresponding to a “no touch” state and a “max touch” state are discussed above with respect to FIG. 12.

FIG. 15 illustrates a perspective view of a top portion of the touch surface panel **704**, in accordance with one embodiment of the invention. The panel **704** includes a plurality of row electrodes **706** separated by a dielectric layer (not shown) from a plurality of column electrodes **708**. In this embodiment, the column electrodes **708** are formed on top of the row electrodes **706** and are substantially orthogonal to the row electrodes. However, other configurations and arrangements would be readily apparent to those of skill in the art. As discussed above, a capacitive sensing node or “pixel” is formed at the intersection of each row electrode **706** and each column electrode **708**. A mutual capacitance is formed at each node when a drive signal is applied to a corresponding row electrode (i.e., drive electrode). In this embodiment, the row electrodes **706** are configured as the drive electrodes and the column electrodes **708** are configured as sense electrodes. In alternative embodiments, the row electrodes **706** may be configured as the sense electrodes and the column electrodes **708** may be configured as the drive electrodes which are driven by a drive input signal applied to the panel **704**.

The top row **710**, however, is touch-insensitive due to the configuration and arrangement of the top portions **712** of the column electrodes **708** above the top row **710**. As shown in FIG. 15, the top portions **712** of the column electrodes **708** are expanded to substantially cover the entirety of the top row **710**, thereby shielding the mutual capacitance (C_{COMP1}) formed between the top row **710** and respective top portions **712** of the column electrodes **708** from any shunting effects that would otherwise be caused by a finger or other object touching the top portion of the panel **704**. Although the top portions **712** are expanded, they do not make electrical contact with adjacent top portions **712**. A bottom touch-insensitive row (not shown) is formed in a similar fashion.

It is understood in alternative embodiments there may only be one touch-insensitive row, or any number of desired touch-insensitive rows or columns. For example, the insensitive portions of the panel **704** may be configured along one

or both side edges of the panel 704 instead of the top and bottom edges. In such a configuration, the row electrodes 706 can be formed on top of the column electrodes 708 with the ends of the row electrodes 706 expanded in a similar manner as the expanded portions 712 of the column electrodes 708.

FIGS. 16A and 16B illustrate the effects of a finger touching a touch-sensitive and a touch-insensitive portion of the panel 704, respectively. Referring to FIG. 16A, when a finger 800 or other object touches or comes in sufficient proximity to (collectively referred to as a “touch” herein) a sensing node formed at an intersection of a column electrode 708 and a row electrode 706, the finger or object blocks or “steals” some of the electric field lines 802 between the column 708 and row 706. These electric field lines are shunted to ground through the capacitance inherent in the finger, and as a result, the steady state signal capacitance C_{SIG} is reduced by ΔC_{SIG} . Therefore, the signal capacitance at the node becomes $C_{SIG} - \Delta C_{SIG}$, where C_{SIG} represents the static (no touch) component and ΔC_{SIG} represents the dynamic (touch) component.

FIG. 16B illustrates the shielding effects of the expanded portions 712 of the column electrodes 708 when a finger touches the corresponding top or bottom portion of the panel 704. Since the expanded portions 712 of the column electrodes substantially cover the entirety of the underlying row electrode 710, the finger 800 is shielded from the underlying electrodes and does not affect the electric field lines 802 between the electrodes. Thus, there is no shunting effect or sensitivity to a touch event at this portion of the panel 704. As discussed above, the touch-insensitive top and bottom rows or portions of the panel 704 may be designed to provide desired values of C_{COMP1} and C_{COMP2} , respectively. Those of skill in the art would readily know how to achieve such desired mutual capacitance values in order to generate a desired compensation signal as described herein.

One advantage of generating the compensation signal through the panel 704, as described above, is that the compensation signal will substantially “track” any variations in the mutual capacitance (C_{SIG}) values present at the touch-sensitive portions of the panel 704 that may be due to, for example, variations in operating parameters (e.g., temperature) and/or processing parameters (e.g., dielectric thickness). Thus, the compensation signal will mimic any variations in the output signals from the touch-sensitive portions of the panel 704. One disadvantage, however, is that the effective surface area of the panel 704 for receiving touch inputs is slightly reduced.

While various embodiments of the present invention have been described above, it should be understood that they have been presented by way of example only, and not of limitation. For example, although the disclosure is primarily directed at devices that utilize capacitive sensing, some or all of the features described herein may be applied to other sensing methodologies. Additionally, although embodiments of this invention are primarily described herein for use with touch sensor panels, proximity sensor panels, which sense “hover” events or conditions, may also be used to generate modulated output signals for detection by the analog channels. Proximity sensor panels are described in Applicants’ co-pending U.S. application Ser. No. 11/649,998 entitled “Proximity and Multi-Touch Sensor Detection and Demodulation,” filed concurrently herewith, the contents of which are incorporated herein by reference in its entirety. As used herein, “touch” events or conditions should be construed to encompass “hover” events and conditions and “touch surface panels” should be construed to encom-

pass “proximity sensor panel.” Likewise, the various diagrams may depict an example architectural or other configuration for the invention, which is done to aid in understanding the features and functionality that can be included in the invention. The invention is not restricted to the illustrated example architectures or configurations, but can be implemented using a variety of alternative architectures and configurations. Additionally, although the invention is described above in terms of various exemplary embodiments and implementations, it should be understood that the various features and functionality described in one or more of the individual embodiments are not limited in their applicability to the particular embodiment with which they are described, but instead can be applied, alone or in some combination, to one or more of the other embodiments of the invention, whether or not such embodiments are described and whether or not such features are presented as being a part of a described embodiment. Thus the breadth and scope of the present invention should not be limited by any of the above-described exemplary embodiments.

Terms and phrases used in this document, and variations thereof, unless otherwise expressly stated, should be construed as open ended as opposed to limiting. As examples of the foregoing: the term “including” should be read as mean “including, without limitation” or the like; the term “example” is used to provide exemplary instances of the item in discussion, not an exhaustive or limiting list thereof; and adjectives such as “conventional,” “traditional,” “normal,” “standard,” “known” and terms of similar meaning should not be construed as limiting the item described to a given time period or to an item available as of a given time, but instead should be read to encompass conventional, traditional, normal, or standard technologies that may be available or known now or at any time in the future. Likewise, a group of items linked with the conjunction “and” should not be read as requiring that each and every one of those items be present in the grouping, but rather should be read as “and/or” unless expressly stated otherwise. Similarly, a group of items linked with the conjunction “or” should not be read as requiring mutual exclusivity among that group, but rather should also be read as “and/or” unless expressly stated otherwise. Furthermore, although items, elements or components of the invention may be described or claimed in the singular, the plural is contemplated to be within the scope thereof unless limitation to the singular is explicitly stated. The presence of broadening words and phrases such as “one or more,” “at least,” “but not limited to” or other like phrases in some instances shall not be read to mean that the narrower case is intended or required in instances where such broadening phrases may be absent.

What is claimed is:

1. A touch sensor panel for generating compensated touch signals, comprising:
 - a plurality of first electrodes; and
 - a plurality of second electrodes;
 wherein the plurality of second electrodes include one or more shielding portions configured for substantially covering an entirety of one or more of the plurality of first electrodes, resulting in the one or more of the plurality of first electrodes becoming touch-insensitive first electrodes.
2. The touch sensor panel of claim 1:
 - wherein one or more of the plurality of first electrodes, different from the touch-insensitive first electrodes, are configured for receiving one or more first stimulation signals; and

19

wherein the one or more touch-insensitive first electrodes are configured for receiving one or more second stimulation signals while the one or more of the plurality of first electrodes, different from the touch-insensitive first electrodes, are receiving the one or more first stimulation signals, the one or more second stimulation signals phase-shifted 180 degrees from the one or more first stimulation signals.

3. The touch sensor panel of claim 1, wherein the plurality of second electrodes are configured for capacitively coupling with the plurality of first electrodes to generate the compensated touch signals.

4. The touch sensor panel of claim 3, wherein one or more of the plurality of second electrodes are configured for capacitively coupling with the one or more touch-insensitive first electrodes and at a same time configured for capacitively coupling with the one or more of the plurality of first electrodes, different from the touch-insensitive first electrodes, to generate the compensated touch signals.

5. The touch sensor panel of claim 4, wherein the one or more of the plurality of second electrodes are configured for producing a fixed capacitance with the one or more touch-insensitive first electrodes.

6. The touch sensor panel of claim 1, wherein the plurality of first electrodes are oriented orthogonal to the plurality of second electrodes, and the one or more shielding portions extend orthogonally from the plurality of second electrodes to cover the entirety of the one or more touch-insensitive first electrodes.

7. The touch sensor panel of claim 1, wherein the plurality of first electrodes are formed on a different layer than the plurality of second electrodes, the plurality of second electrodes being closer to a touch surface of the touch sensor panel than the plurality of first electrodes.

8. The touch sensor panel of claim 1, at least one of the touch-insensitive first electrodes located near an edge of the touch sensor panel.

9. The touch sensor panel of claim 1, incorporated into a hand-held computing device.

10. A method for generating compensated touch signals, comprising:

forming a plurality of first electrodes;
forming a plurality of second electrodes; and
substantially covering an entirety of one or more of the plurality of first electrodes with one or more shielding portions of the plurality of second electrodes, resulting in the one or more of the plurality of first electrodes becoming touch-insensitive first electrodes.

11. The method of claim 10, further comprising:
receiving one or more first stimulation signals at one or more of the plurality of first electrodes, different from the touch-insensitive first electrodes;
receiving one or more second stimulation signals at the one or more touch-insensitive first electrodes while receiving the one or more first stimulation signals at the

20

one or more of the plurality of first electrodes, different from the touch-insensitive first electrodes; and
phase-shifting the one or more second stimulation signals 180 degrees from the one or more first stimulation signals.

12. The method of claim 10, further comprising capacitively coupling the plurality of second electrodes with the plurality of first electrodes to generate the compensated touch signals.

13. The method of claim 12, further comprising capacitively coupling one or more of the plurality of second electrodes with the one or more touch-insensitive first electrodes, and at a same time capacitively coupling the one or more of the plurality of second electrodes with the one or more of the plurality of first electrodes, different from the touch-insensitive first electrodes, to generate the compensated touch signals.

14. The method of claim 13, further comprising producing a fixed capacitance between the one or more of the plurality of second electrodes and the one or more touch-insensitive first electrodes.

15. The method of claim 10, further comprising orienting the plurality of first electrodes orthogonal to the plurality of second electrodes, and extending the one or more shielding portions orthogonally from the plurality of second electrodes to cover the entirety of the one or more touch-insensitive first electrodes.

16. The method of claim 10, further comprising forming the plurality of first electrodes on a different layer than the plurality of second electrodes, and locating the plurality of second electrodes closer to a touch surface of the touch sensor panel than the plurality of first electrodes.

17. The method of claim 10, further comprising locating at least one of the touch-insensitive first electrodes near an edge of the touch sensor panel.

18. A touch sensor panel for generating compensated touch signals, comprising:

a plurality of first electrodes;
a plurality of second electrodes; and
wherein the plurality of second electrodes includes one or more shielding portions for rendering one or more of the first electrodes touch-insensitive.

19. The touch sensor panel of claim 18, further comprising a capacitive sensing circuit configured for capacitively coupling an out-of-phase noise signal onto the plurality of second electrodes for canceling noise on touch signals generated on the plurality of second electrodes.

20. The touch sensor panel of claim 19, the capacitive sensing circuit further configured for combining the out-of-phase noise signals and the touch signals including a noise component on the plurality of second electrodes.

* * * * *