

US010224408B2

(12) **United States Patent**
Gaevski et al.

(10) **Patent No.:** **US 10,224,408 B2**
(45) **Date of Patent:** ***Mar. 5, 2019**

(54) **PERFORATING CONTACT TO SEMICONDUCTOR LAYER**

(71) Applicant: **Sensor Electronic Technology, Inc.**,
Columbia, SC (US)

(72) Inventors: **Mikhail Gaevski**, West Columbia, SC (US); **Grigory Simin**, Columbia, SC (US); **Maxim S. Shatalov**, Columbia, SC (US); **Alexander Dobrinsky**, Loudonville, NY (US); **Michael Shur**, Latham, NY (US); **Remigijus Gaska**, Columbia, SC (US)

(73) Assignee: **Sensor Electronic Technology, Inc.**,
Columbia, SC (US)

(*) Notice: Subject to any disclaimer, the term of this patent is extended or adjusted under 35 U.S.C. 154(b) by 0 days.

This patent is subject to a terminal disclaimer.

(21) Appl. No.: **15/601,128**

(22) Filed: **May 22, 2017**

(65) **Prior Publication Data**

US 2017/0256623 A1 Sep. 7, 2017

Related U.S. Application Data

(60) Division of application No. 14/636,546, filed on Mar. 3, 2015, now Pat. No. 9,660,043, which is a
(Continued)

(51) **Int. Cl.**
H01L 33/38 (2010.01)
H01L 29/45 (2006.01)

(Continued)

(52) **U.S. Cl.**
CPC **H01L 29/452** (2013.01); **H01L 21/28575** (2013.01); **H01L 21/28587** (2013.01);

(Continued)

(58) **Field of Classification Search**
None

See application file for complete search history.

(56) **References Cited**

U.S. PATENT DOCUMENTS

6,946,682 B2 9/2005 Slater, Jr. et al.
7,601,993 B2 10/2009 Hoshi et al.

(Continued)

FOREIGN PATENT DOCUMENTS

KR 101990039343 6/1999
KR 1020060040422 5/2006

(Continued)

OTHER PUBLICATIONS

Ahn, C. et al., "30-nm recessed S/D SOI MOSFET with an ultrathin body and a low SDE resistance", IEEE Electron Device Letters, Jul. 2005, 3 pages, vol. 26, No. 7.

(Continued)

Primary Examiner — Benjamin Sandvik

(74) *Attorney, Agent, or Firm* — LaBatt, LLC

(57) **ABSTRACT**

A perforating ohmic contact to a semiconductor layer in a semiconductor structure is provided. The perforating ohmic contact can include a set of perforating elements, which can include a set of metal protrusions laterally penetrating the semiconductor layer(s). The perforating elements can be separated from one another by a characteristic length scale selected based on a sheet resistance of the semiconductor layer and a contact resistance per unit length of a metal of the perforating ohmic contact contacting the semiconductor layer. The structure can be annealed using a set of conditions configured to ensure formation of the set of metal protrusions.

20 Claims, 14 Drawing Sheets

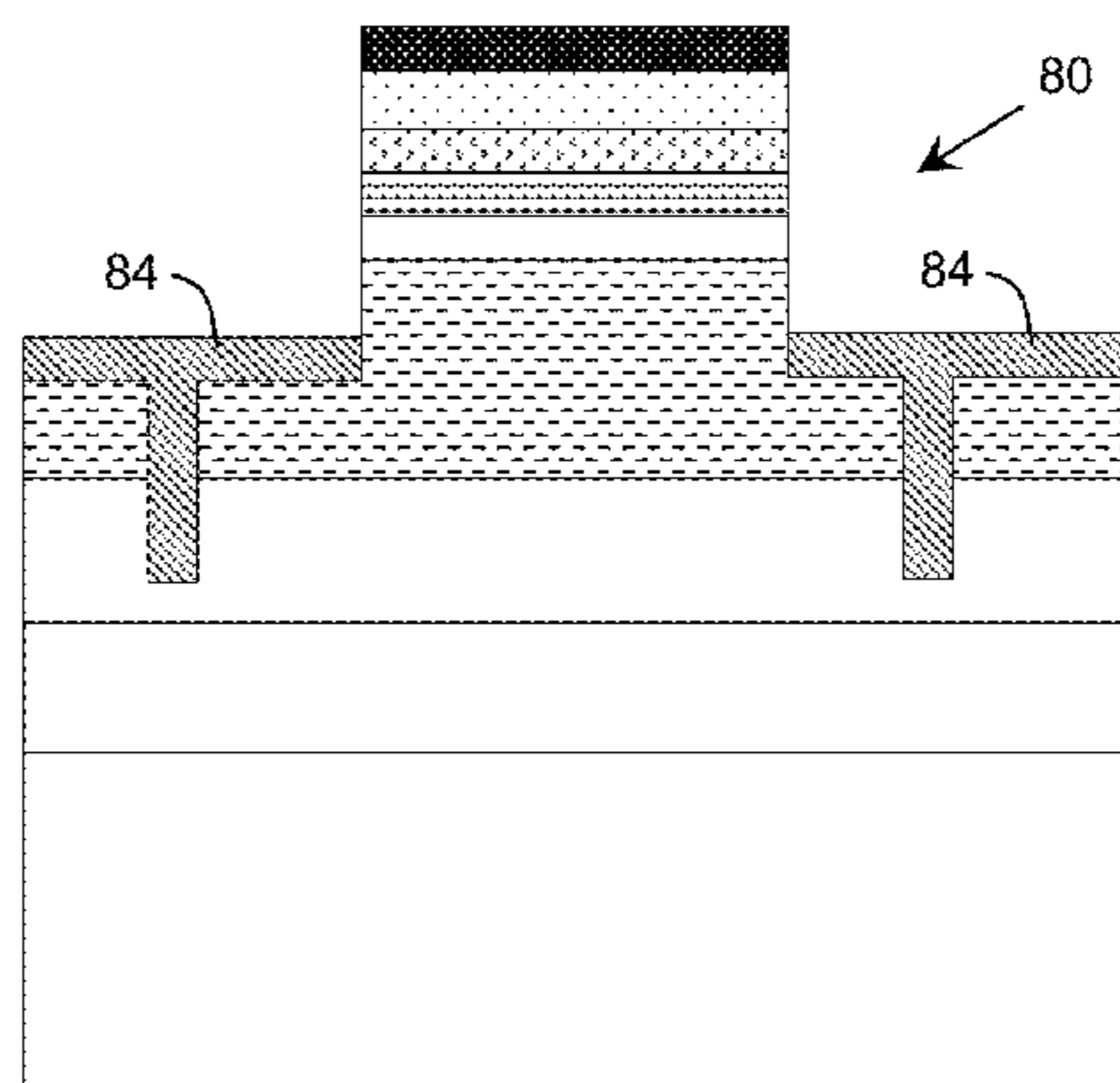

Related U.S. Application Data

continuation-in-part of application No. 13/909,621, filed on Jun. 4, 2013, now Pat. No. 8,969,198.

(60) Provisional application No. 61/655,437, filed on Jun. 4, 2012.

(51) Int. Cl.

H01L 29/20 (2006.01)

H01L 21/285 (2006.01)

H01L 29/417 (2006.01)

H01L 29/778 (2006.01)

(52) U.S. Cl.

CPC *H01L 21/28593* (2013.01); *H01L 29/2003* (2013.01); *H01L 29/4175* (2013.01); *H01L 29/41766* (2013.01); *H01L 33/382* (2013.01); *H01L 29/7787* (2013.01); *H01L 2933/0016* (2013.01)

(56) References Cited

U.S. PATENT DOCUMENTS

7,923,753	B2	4/2011	Mita et al.
8,525,227	B2	9/2013	Jeon et al.
8,604,511	B2	12/2013	Bennett et al.
8,735,941	B2	5/2014	Park et al.
8,941,146	B2	1/2015	Kanamura
8,969,198	B2	3/2015	Gaevski et al.
9,660,043	B2	5/2017	Gaevski et al.
2002/0142548	A1	10/2002	Takaishi
2005/0059178	A1	3/2005	Erchak et al.
2006/0056123	A1	3/2006	Aoyagi et al.
2007/0187677	A1	8/2007	Park et al.
2008/0173898	A1	7/2008	Ohmaki
2008/0217625	A1	9/2008	Kuroda et al.
2008/0258150	A1	10/2008	McCarthy et al.
2009/0035884	A1	2/2009	Ikuta
2009/0127575	A1	5/2009	Hornig et al.
2009/0212276	A1	8/2009	Hong et al.
2010/0059781	A1	3/2010	Yokobayashi et al.
2011/0018024	A1	1/2011	Fukushima et al.
2011/0143507	A1	6/2011	Mun et al.
2011/0198641	A1	8/2011	Yahata et al.
2011/0233520	A1	9/2011	Jeon et al.
2011/0233596	A1	9/2011	Sano et al.
2011/0235665	A1	9/2011	Simon et al.
2012/0049152	A1	3/2012	Schubert
2012/0235204	A1	9/2012	Hodota et al.
2012/0248500	A1	10/2012	Kajitani
2013/0026519	A1	1/2013	Huang et al.
2013/0320352	A1	12/2013	Gaevski et al.
2014/0016660	A1	1/2014	Lunev et al.
2014/0264454	A1	9/2014	Banerjee et al.
2015/0014628	A1	1/2015	Chung
2017/0200865	A1	7/2017	Brummer et al.

FOREIGN PATENT DOCUMENTS

KR	100786091	B1	12/2007
KR	100826375	B1	5/2008
WO	2011074166	A1	6/2011

OTHER PUBLICATIONS

Chen, C. et al., "High-transconductance self-aligned AlGaIn/GaN modulation-doped field-effect transistors with regrown ohmic contacts", Applied Physics Letters, 1998, 4 pages, vol. 73, No. 21.

Chiu, C.H. et al., "Fabrication and characteristics of thin-film InGaIn—GaN light-emitting diodes with TiO₂/SiO₂ omnidirectional reflectors," Semiconductor Science and Technology, Jul. 2007, 6 pages, vol. 22, No. 7.

Gessmann et al., "GaInN light-emitting diodes with omnidirectional reflectors", 2003, 6 pages, vol. 4996.

Gessmann et al., "High-efficiency AlGaInP light-emitting diodes for solid-state lighting applications," J. Appl. Phys., 2004, 15 pages, vol. 95, No. 5.

Hong-Xia, M. et al., "A Novel Ni/Ag/Pt Ohmic Contact to P-Type GaN for Flip-Chip Light-Emitting Diodes," Chinese Phys. Lett., Aug. 2006, 5 pages, vol. 23, No. 8.

Huang H.W. et al., "High-Performance GaN-Based Vertical-Injection Light-Emitting Diodes With TiO₂—SiO₂ Omnidirectional Reflector and n-GaN Roughness," IEEE Photonics Technology Letters, 2007, 3 pages, vol. 19, No. 8.

Huang, H.W. et al., "Improvement of light output in GaN-based power chip light-emitting diodes with a nano-rough surface by nanoimprint lithography," Semicond. Sci. Technol., Apr. 2008, 5 pages, vol. 23, No. 4.

Jang, J. et al., "Low-resistance and thermally stable indium tin oxide Ohmic contacts on strained p-In_{0.15}Ga_{0.85}N/p-GaN layer," Journal of Applied Physics, 2007, 5 pages, vol. 101, No. 1.

Ke, W. et al., "Recessed source/drain for sub-50 nm UTB SOI MOSFET," Semiconductor Science and Technology, May 2007, 8 pages, vol. 22, No. 5.

Kim, J. et al., "Enhanced light-extraction in GaInN near-ultraviolet light-emitting diode with Al-based omnidirectional reflector having NiZn/Ag microcontacts," Applied Physics Letters, 2006, 4 pages, vol. 89, No. 14.

Kim, J. et al., "GaInN light-emitting diode with conductive omnidirectional reflector having a low-refractive-index indium-tin oxide layer," Applied Physics Letters, 2006, 4 pages, vol. 88, No. 1.

Kim, J. et al., "GaInN light-emitting diodes with RuO₂/SiO₂/Ag omnidirectional reflector", Applied Physics Letters, 2004, 3 pages, vol. 84, No. 22.

Lee, C. et al., "Effects of strained InGaIn interlayer on contact resistance between p-GaN and indium tin oxide," Applied Physics Letters, 2007, 4 pages, vol. 90, No. 18.

Lee, W. et al., "Enhanced Light Output of Vertical-Structured GaN-Based Light-Emitting Diodes with TiO₂/SiO₂ Reflector and Roughened GaOx Surface Film," Japanese Journal of Applied Physics, Apr. 2011, 4 pages, vol. 50, No. 4.

Lin, C.H. et al., "Enhancement of InGaInGaN Indium-Tin-Oxide Flip-Chip Light-Emitting Diodes With TiO₂/SiO₂ Multilayer Stack Omnidirectional Reflector", IEEE Photonics Technology Letters, Oct. 2006, 3 pages, vol. 18, No. 19.

Peng, L. et al., "GaN-Based LEDs With GaN-Pillars Around Mesa, Patterned Substrate, and Reflector Under Pads," IEEE Photonics Technology Letters, Nov. 15, 2009, 3 pages, vol. 21, No. 22.

Schubert, M. et al., "Distributed Bragg reflector consisting of high- and low-refractive-index thin film layers made of the same material," Applied Physics Letters, 2007, 3 pages, vol. 90, No. 14.

Schubert, E. et al., "Solid-state lighting—a benevolent technology," Rep. Prog. Phys., Dec. 2006, 31 pages, vol. 69, No. 12.

Selvaraj S. et al., "AlN/AlGaIn/GaN MIS-HEMTs with recessed source/drain Ohmic contact," physica status solidi, Jul. 2008, 3 pages, vol. 5, No. 9.

Sheu, J. K. et al., "Enhancement in output power of blue gallium nitride-based light-emitting diodes with omnidirectional metal reflector under electrode pads," Applied Physics Letters, 2008, 4 pages, vol. 93, No. 10.

Song J. et al., "Ohmic-Contact Technology for GaN-Based Light-Emitting Diodes: Role of P-Type Contact," IEEE Trans. Electron Devices, Jan. 2010, 18 pages, vol. 57, No. 1.

Wang, T. et al., "Highly improved performance of a 350nm ultraviolet light-emitting diode containing Al_xGa_{1-x}N/Al_yGa_{1-y}N distributed Bragg reflectors," Journal of Crystal Growth, Jul. 2004, 5 pages, vol. 267, No. 3-4.

Xie, Z.L. et al., "High reflectivity AlGaIn/AlN DBR mirrors grown by MOCVD," Journal of Crystal Growth, Jan. 2007, 4 pages, vol. 298.

Yamada, M. et al., "InGaIn-Based Near-Ultraviolet and Blue-Light-Emitting Diodes with High External Quantum Efficiency Using a Patterned Sapphire Substrate and a Mesh Electrode," Dec. 2002, 3 pages, vol. 41, No. Part 2, No. 12B.

Yan-Xu, Z. et al., "Flip-Chip GaN-Based Light-Emitting Diodes with Mesh-Contact Electrodes," Jan. 2007, 4 pages, vol. 24, No. 1.

(56)

References Cited

OTHER PUBLICATIONS

Zhang, Z. et al., "Self-Align Recessed Source Drain Ultrathin Body SOI MOSFET," IEEE Electron Device Letters, Nov. 2004, 3 pages, vol. 25, No. 11.

Zhu, Y. et al., "Enhanced output of GaN-based light-emitting diodes with stripe-contact electrodes," Applied Physics Letters, 2006, 4 pages, vol. 89, No. 8.

Zopler, J.C. et al., "Ion-implanted GaN junction field effect transistor," Applied Physics Letters, 1996, 4 pages, vol. 68, No. 16.

Sandvik, B., U.S. Appl. No. 14/636,546, Notice of Allowance, dated Jan. 20, 2017, 10 pages.

Sandvik, B., U.S. Appl. No. 14/636,546, Final Office Action1, dated Sep. 20, 2016, 8 pages.

Sandvik, B., U.S. Appl. No. 14/636,546, Office Action1, dated May 31, 2016, 20 pages.

Rodela, E., U.S. Appl. No. 13/940,515, Notice of Allowance, dated Dec. 8, 2015, 15 pages.

Rodela, E., U.S. Appl. No. 13/940,515, Office Action 2, dated Jul. 2, 2015, 24 pages.

Rodela, E., U.S. Appl. No. 13/940,515, Final Office Action 1, dated Jan. 30, 2015, 22 pages.

Rodela, E., U.S. Appl. No. 13/940,515, Office Action 1, dated Jul. 10, 2014, 29 pages.

Rodela, E., U.S. Appl. No. 14/984,511, Notice of Allowance, dated Jun. 16, 2017, 12 pages.

Rodela, E., U.S. Appl. No. 14/984,511, Office Action 1, dated Jan. 3, 2017, 23 pages.

Park., International Search Report and Written Opinion for International Application No. PCT/US2013/050215, dated Sep. 26, 2013, 13 pages.

Choi, International Search Report and Written Opinion for International Application No. PCT/US2013/0044065, dated Sep. 6, 2013, 9 pages.

White, U.S. Appl. No. 13/909,621, Notice of Allowance, dated Oct. 8, 2014, 14 pages.

Rodela, E., U.S. Appl. No. 15/784,905, Office Action1, dated Mar. 30, 2018, 26 pages.

Rodela, E., U.S. Appl. No. 15/784,905, Final Office Action, dated Nov. 1, 2018, 18 pages.

FIG. 1A

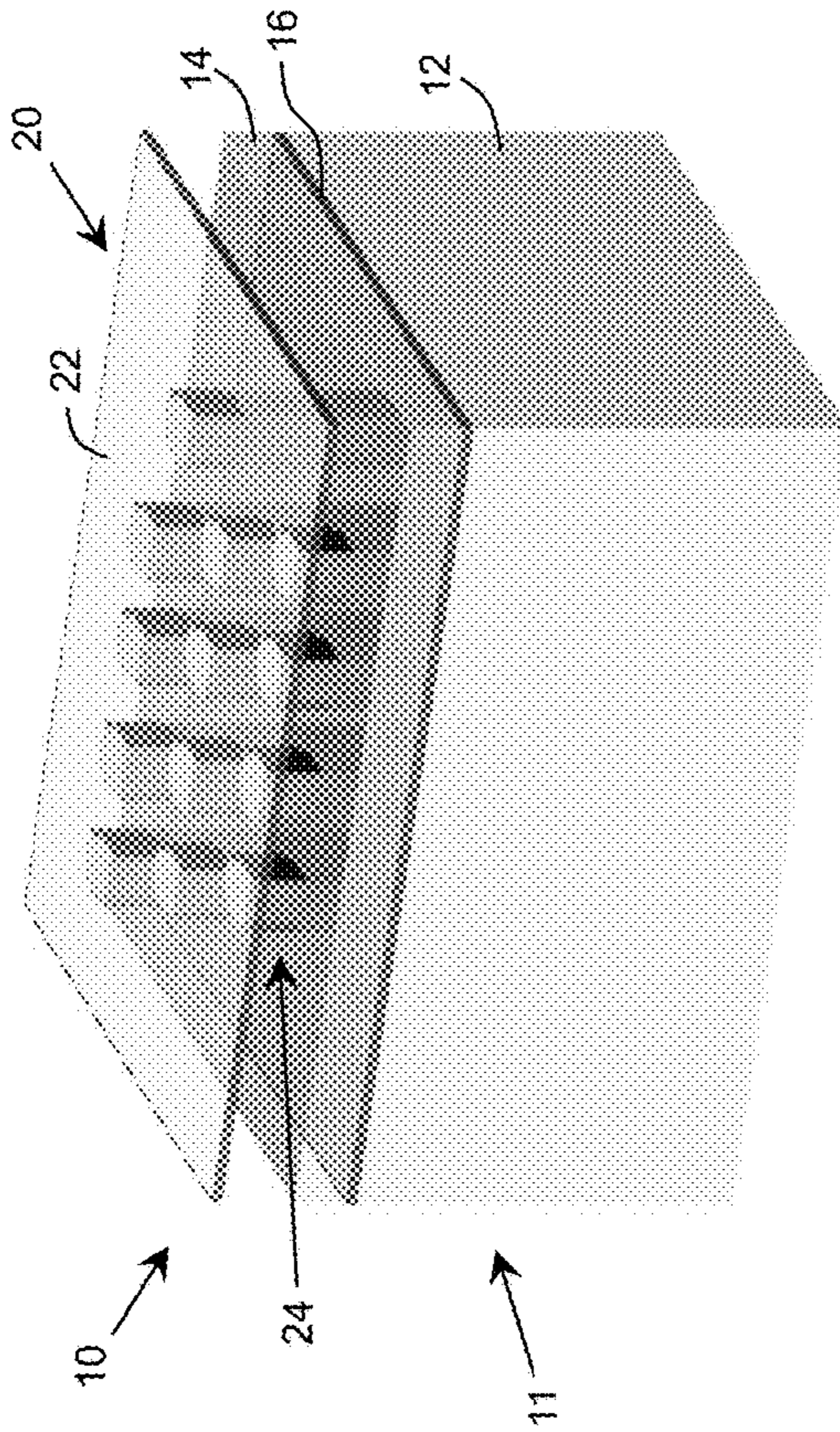

FIG. 1B

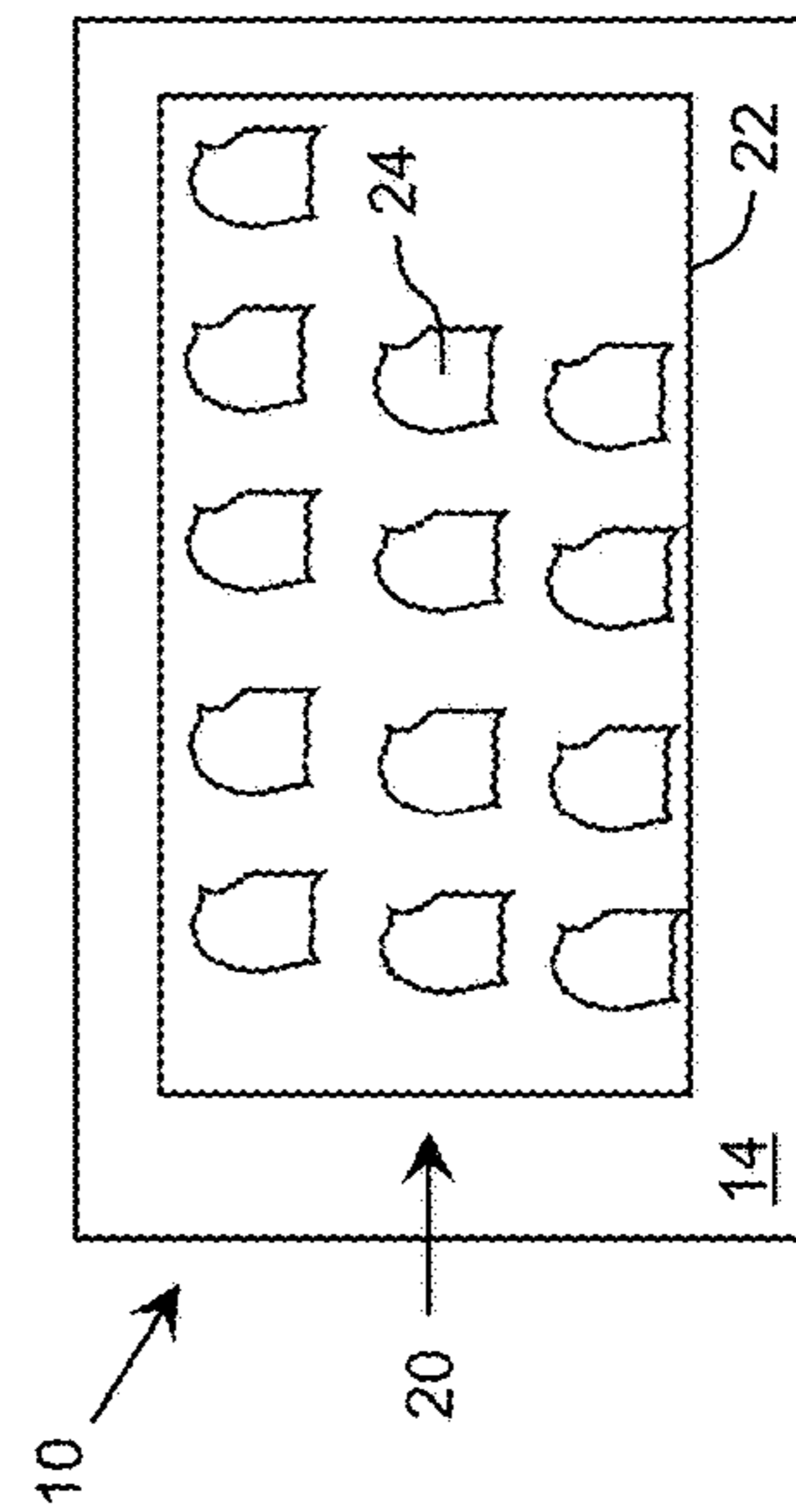
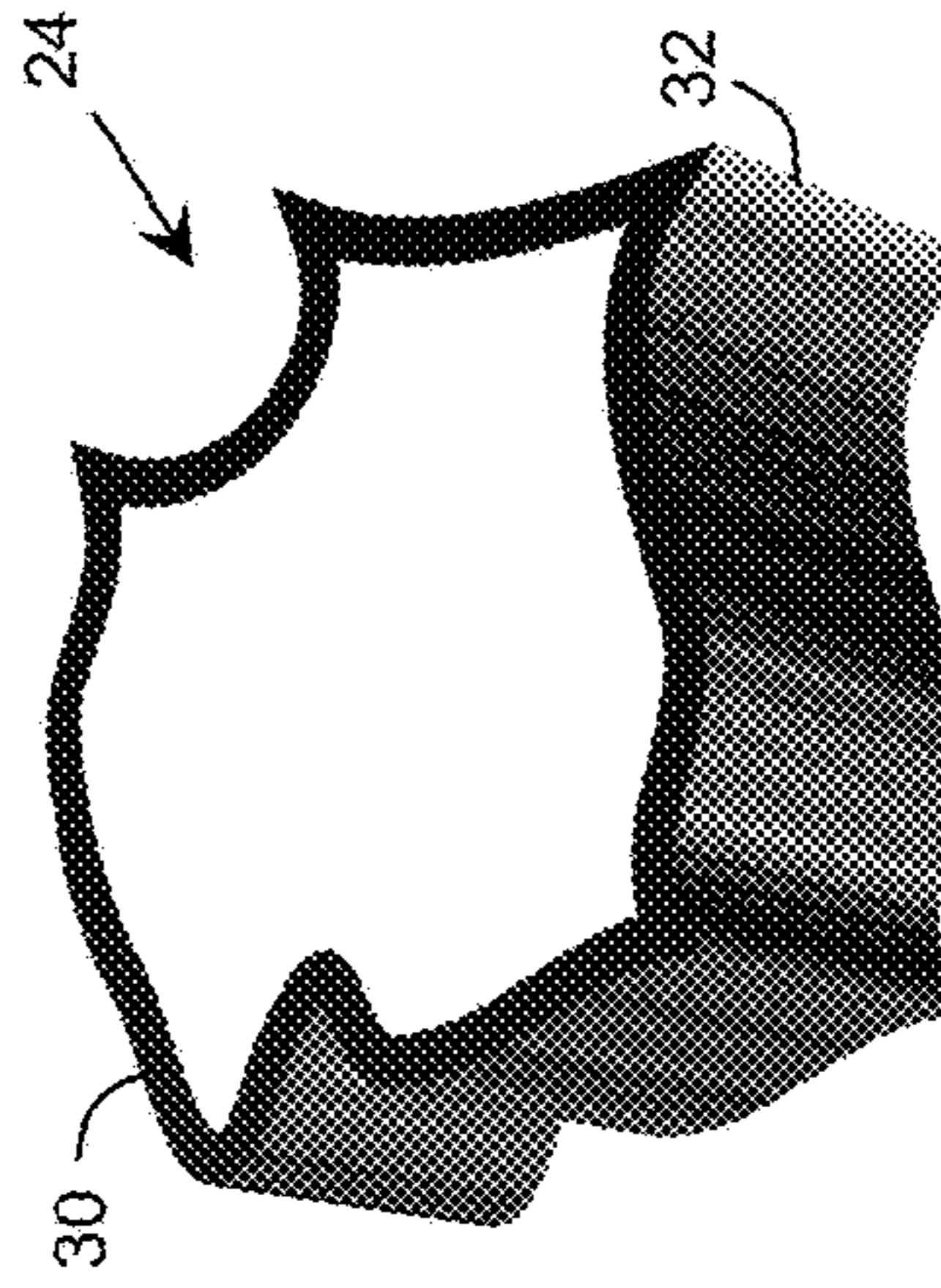

FIG. 1C



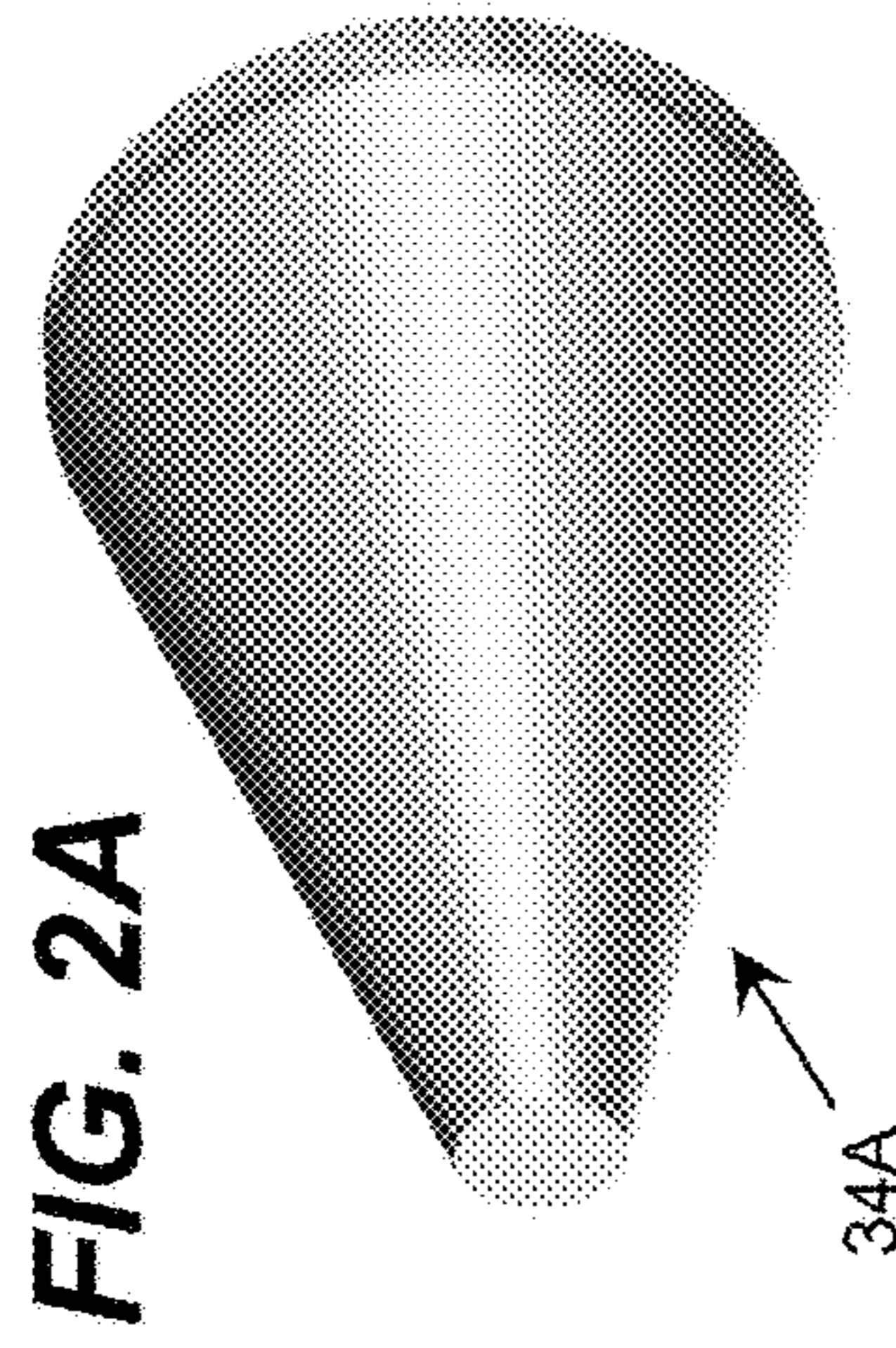

FIG. 2E

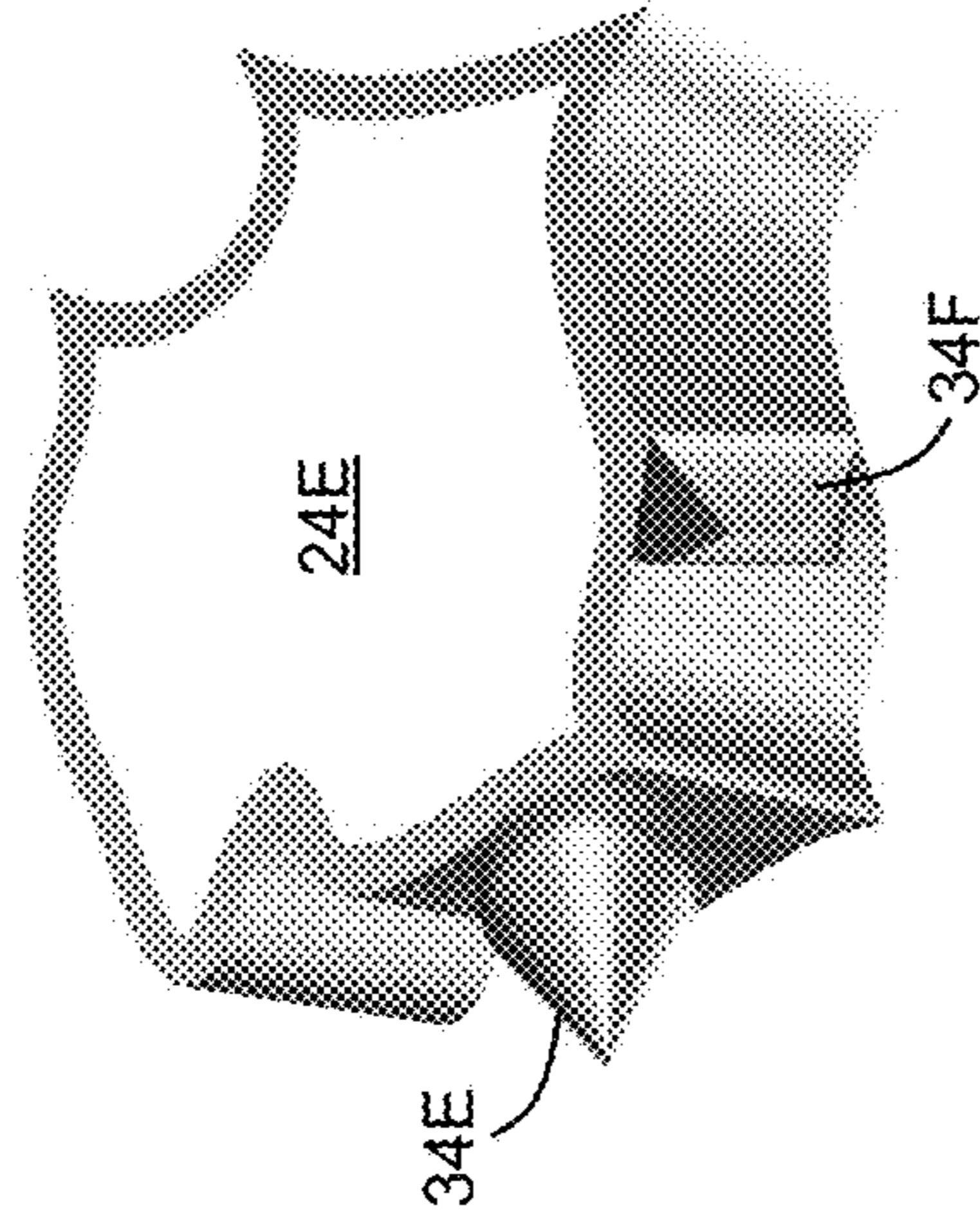

FIG. 2B

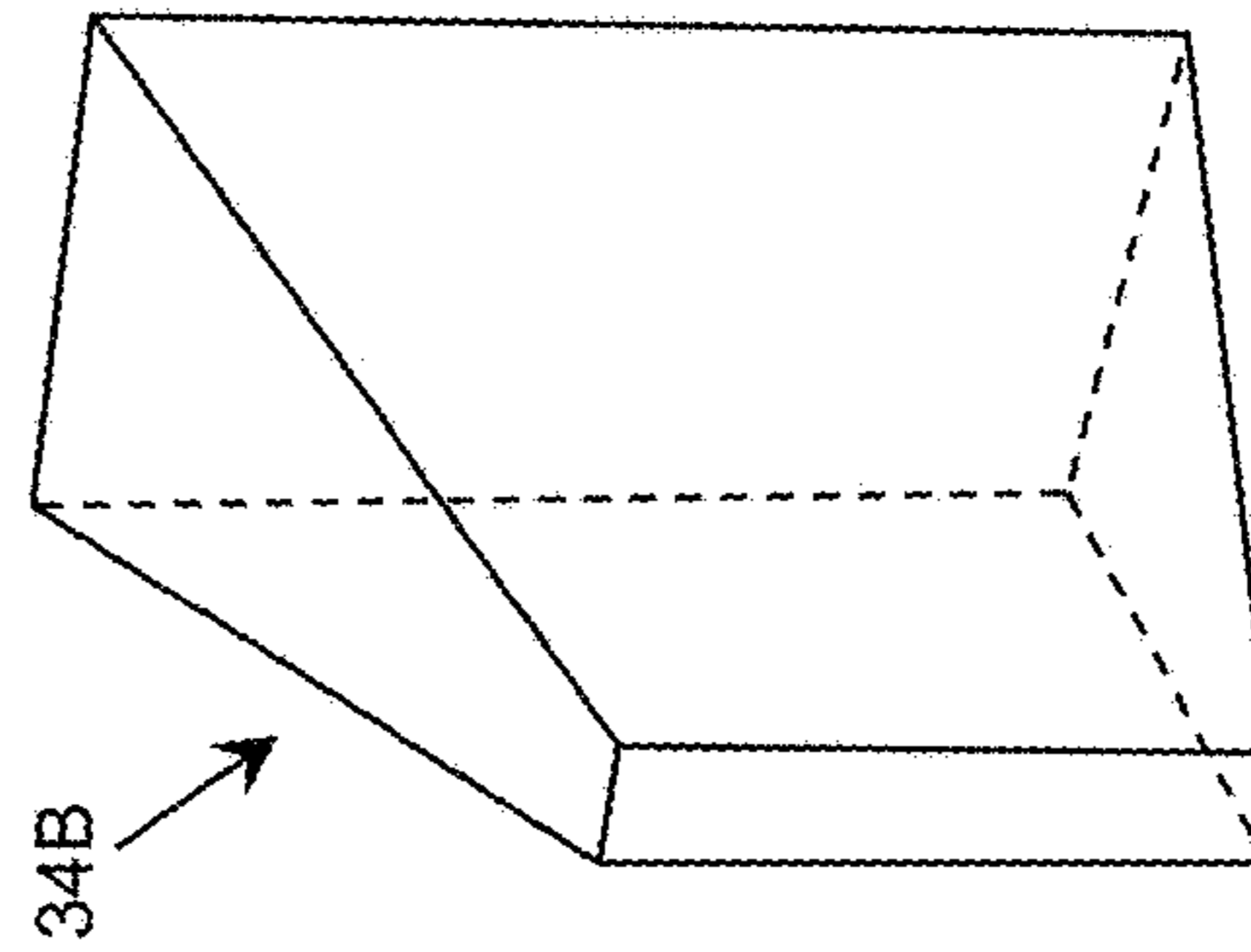

FIG. 2C

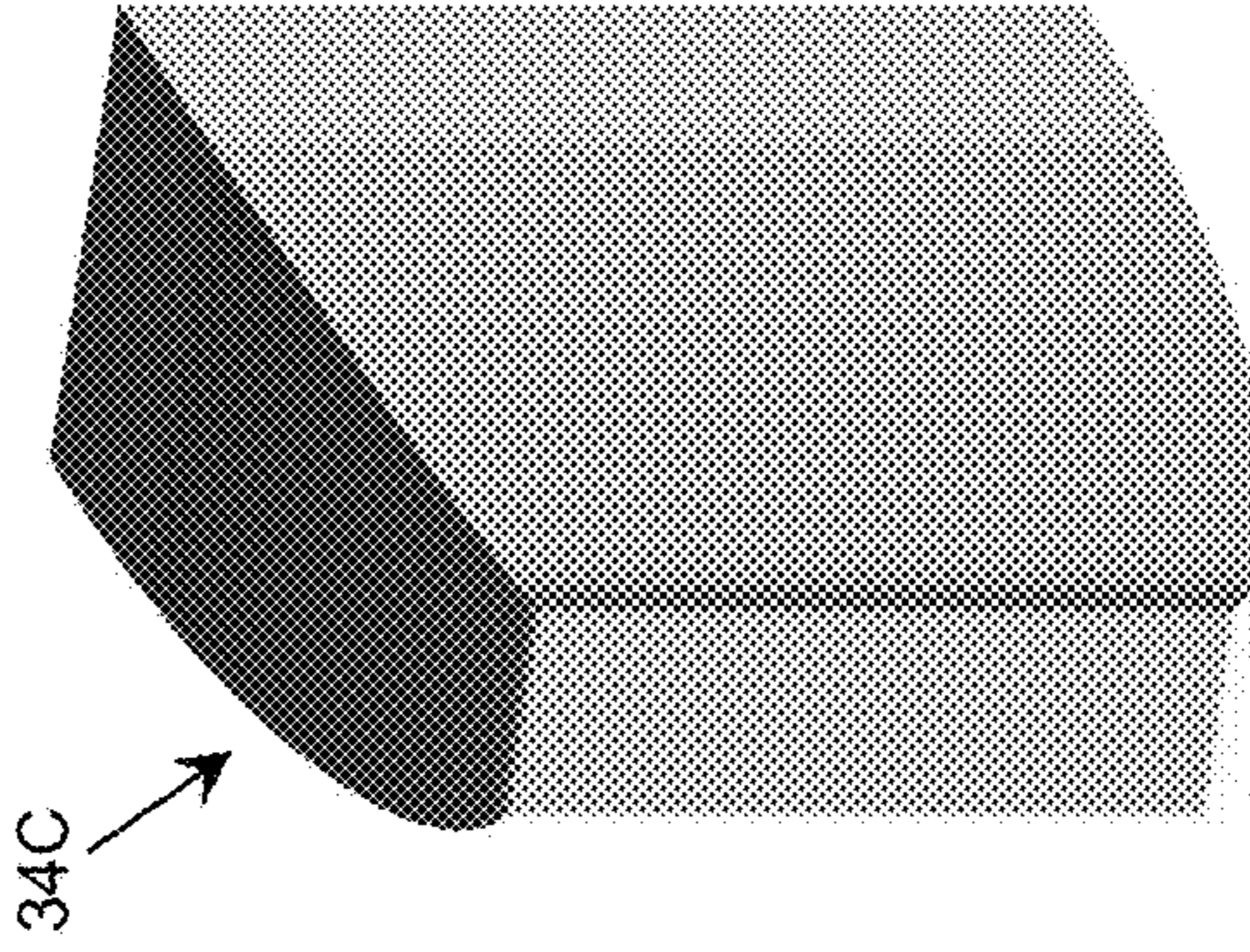

FIG. 2D

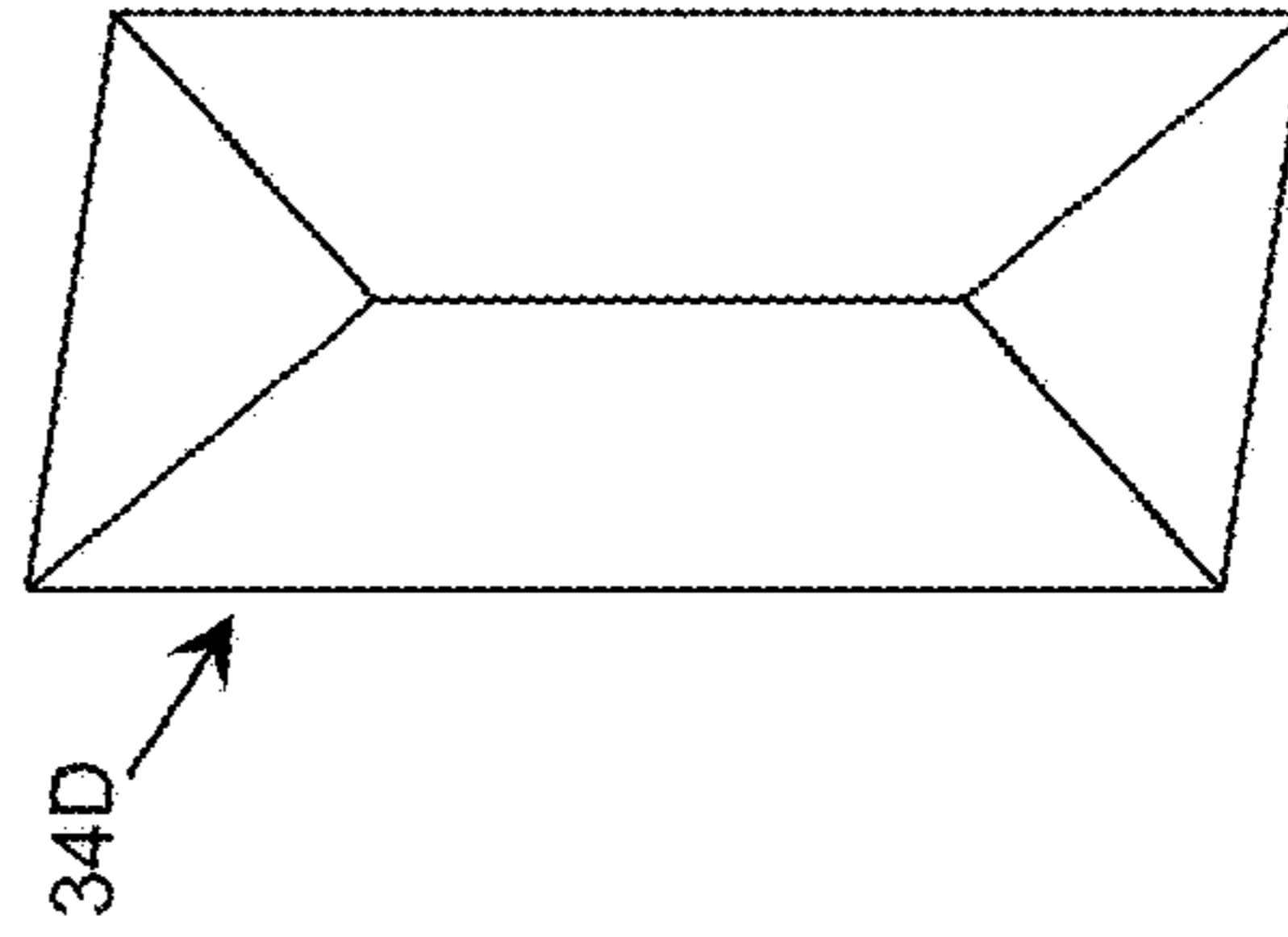

FIG. 3A

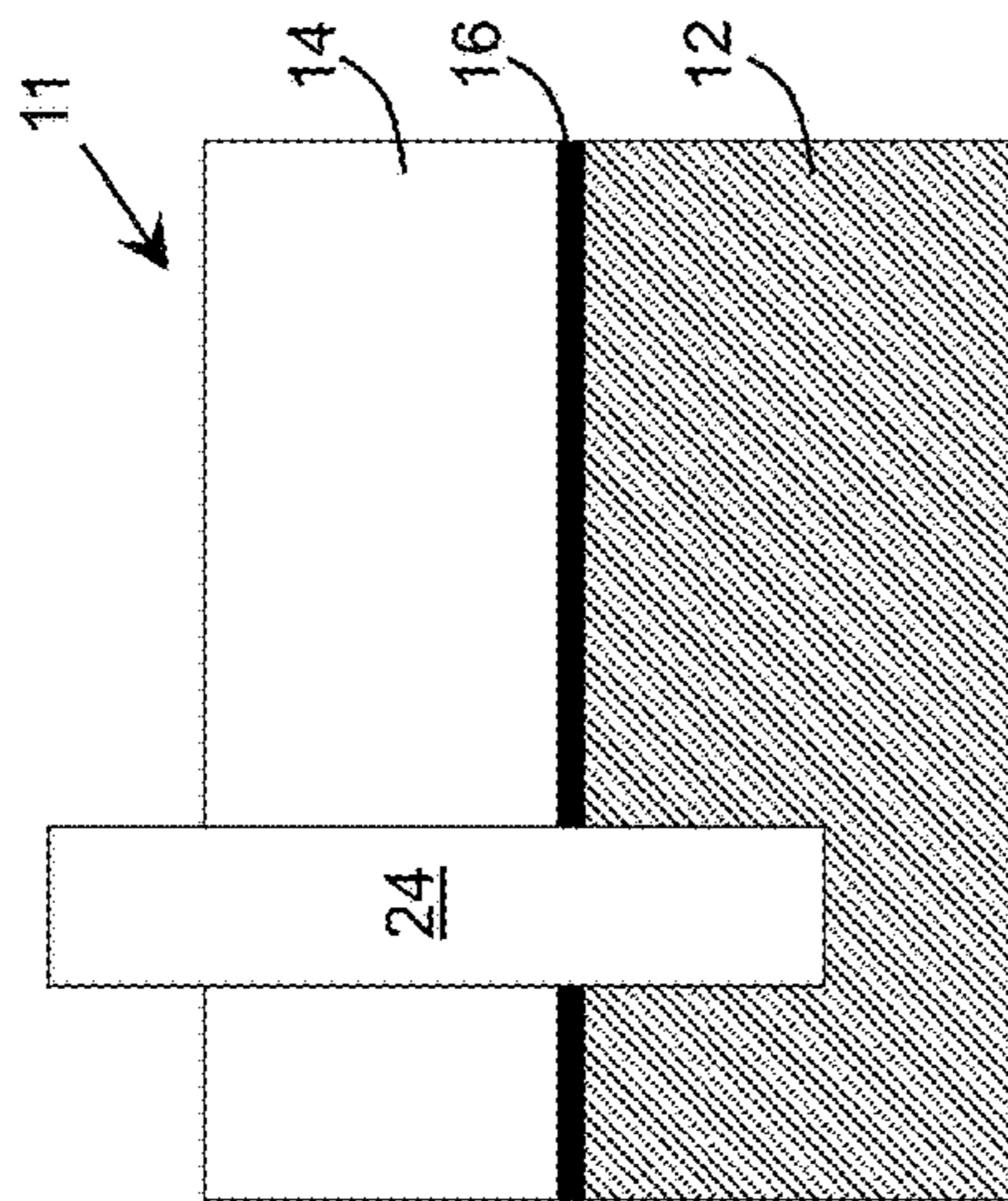
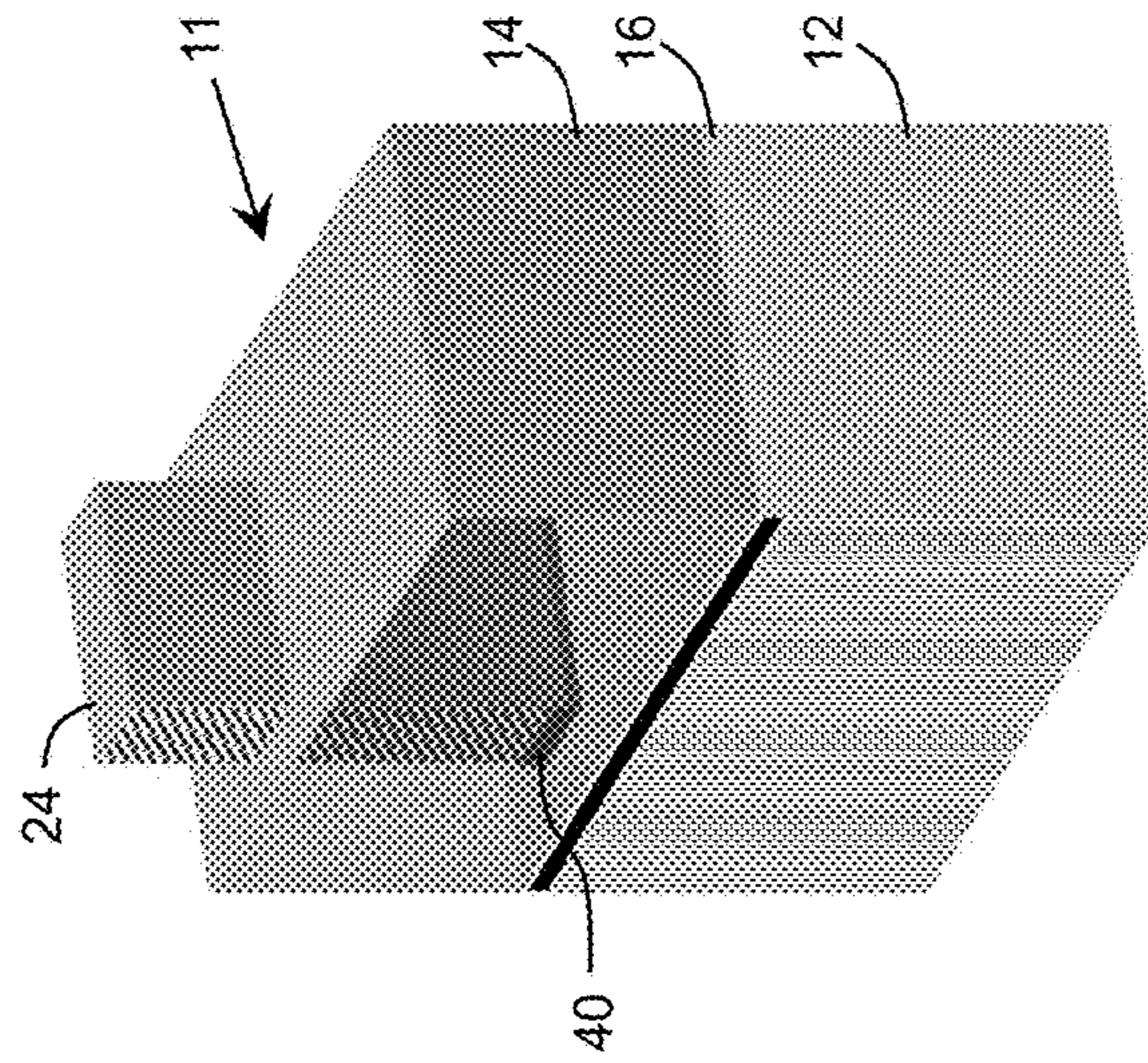

FIG. 3B



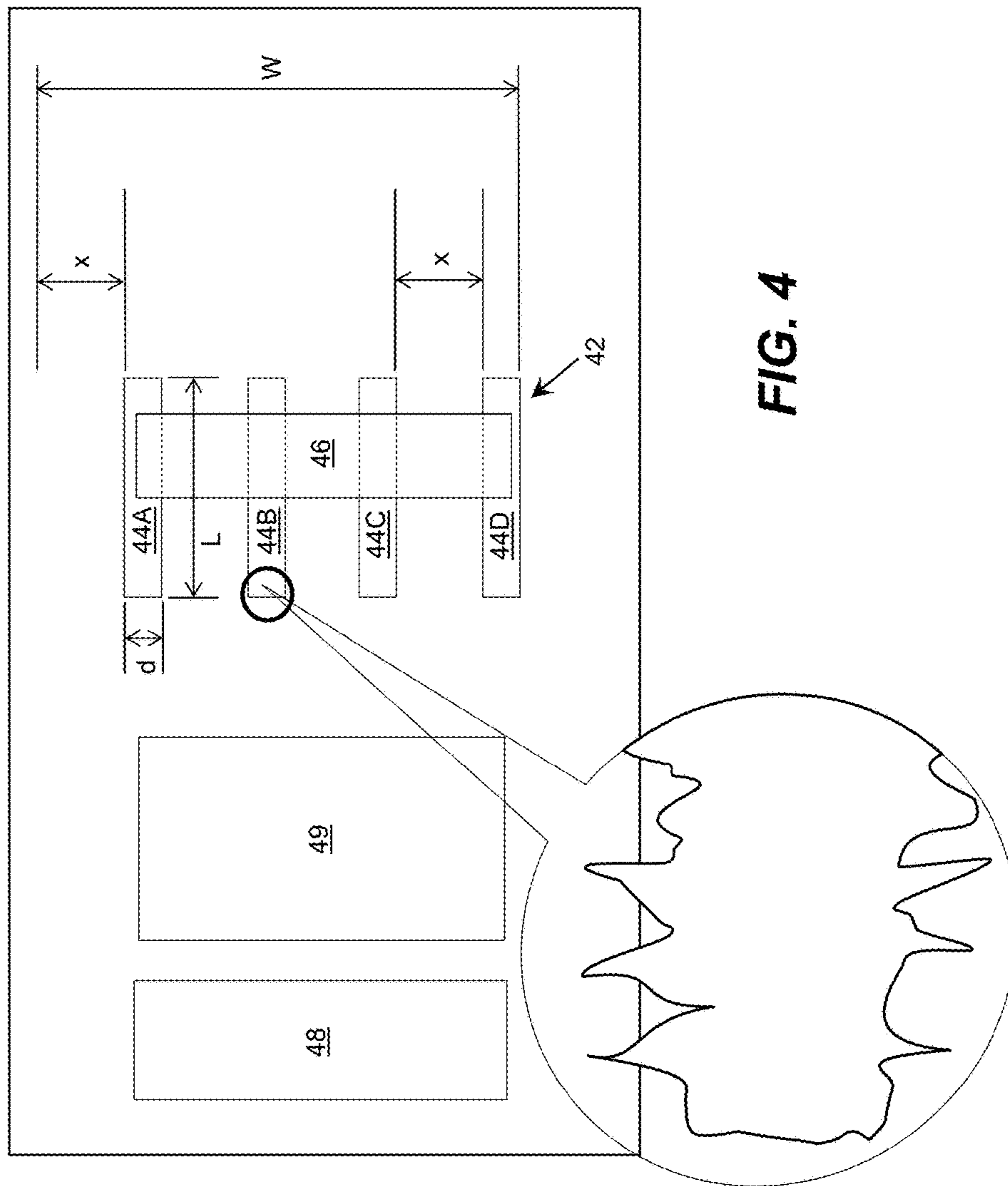
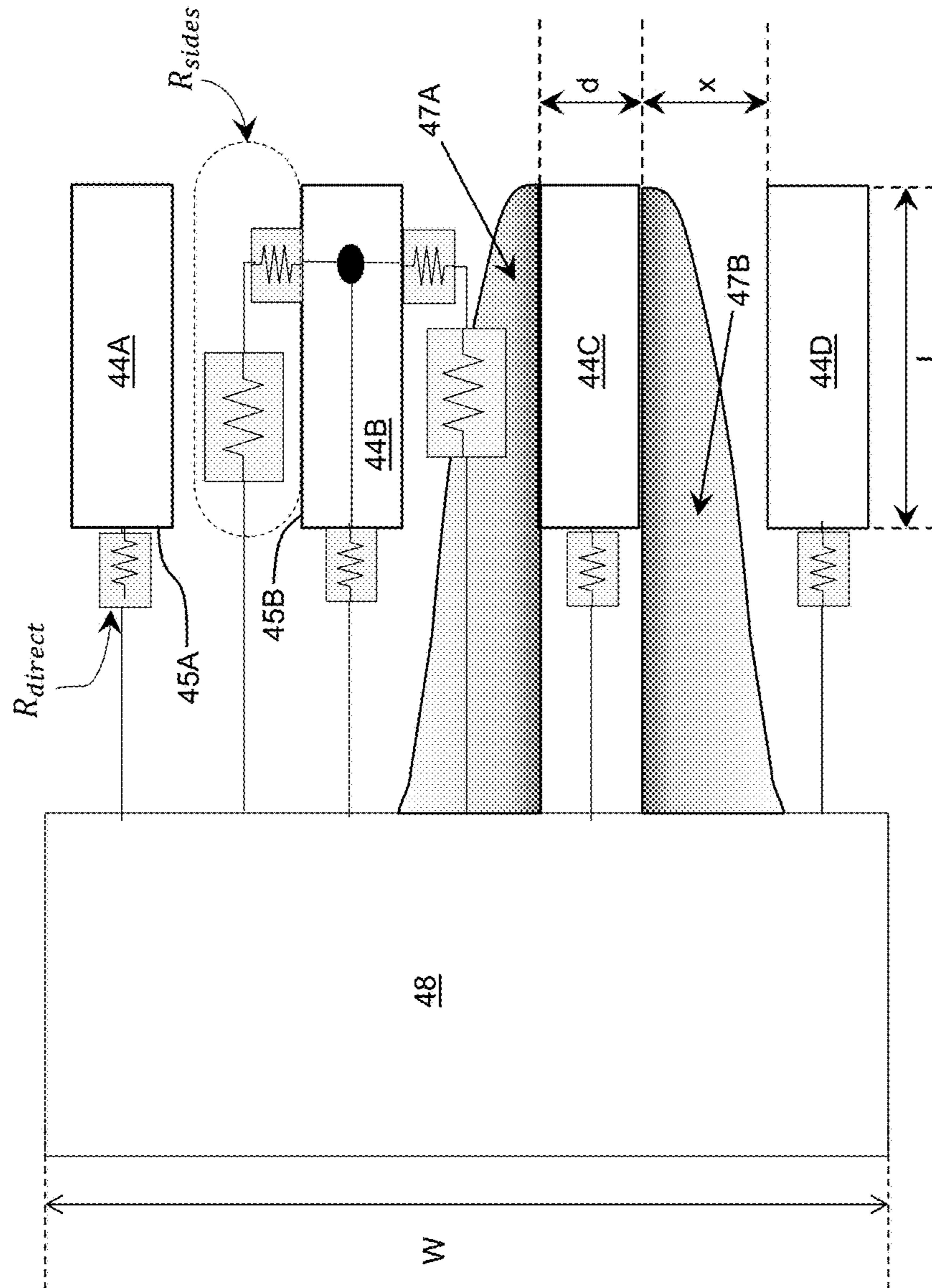

FIG. 4

FIG. 5



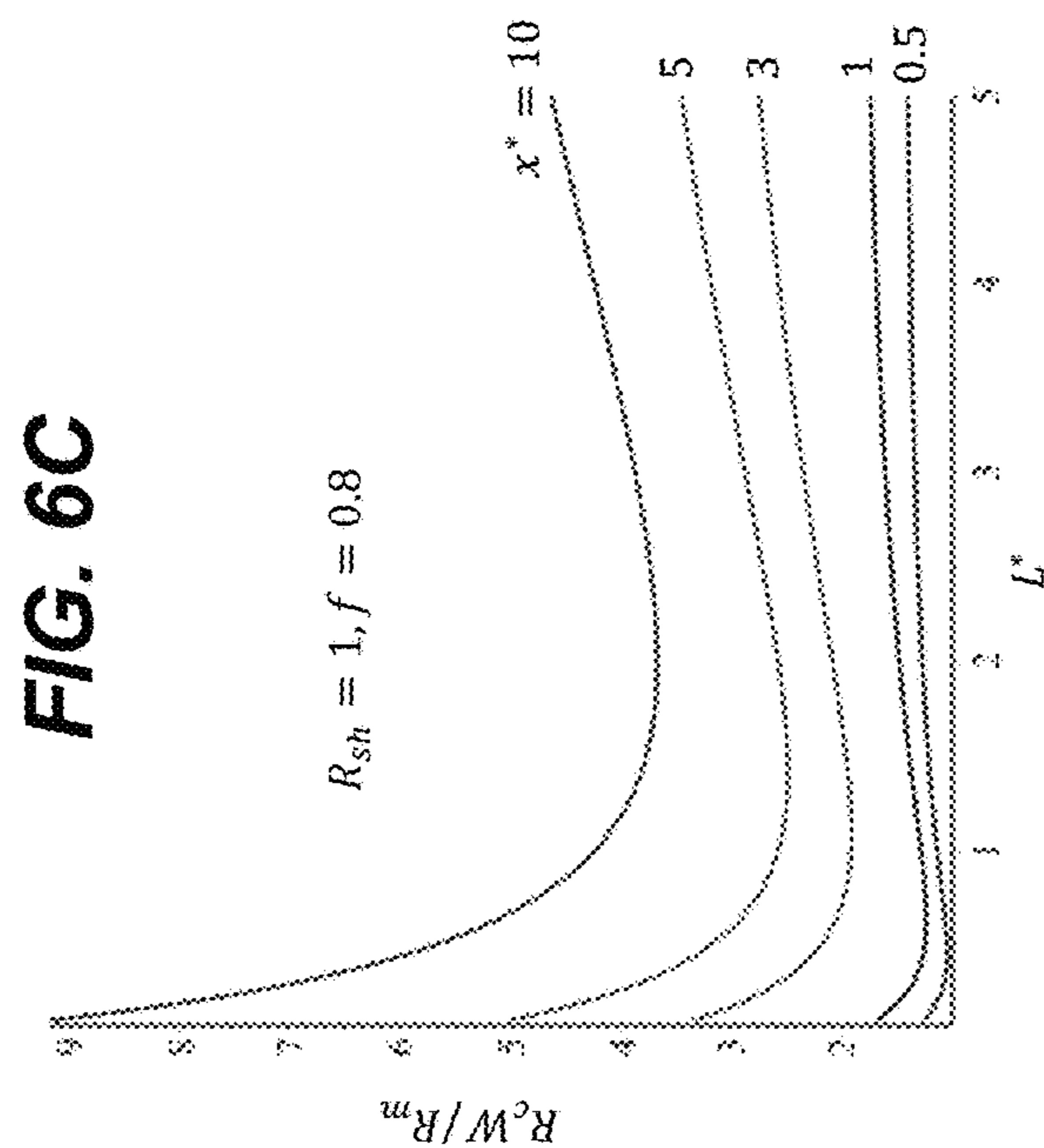
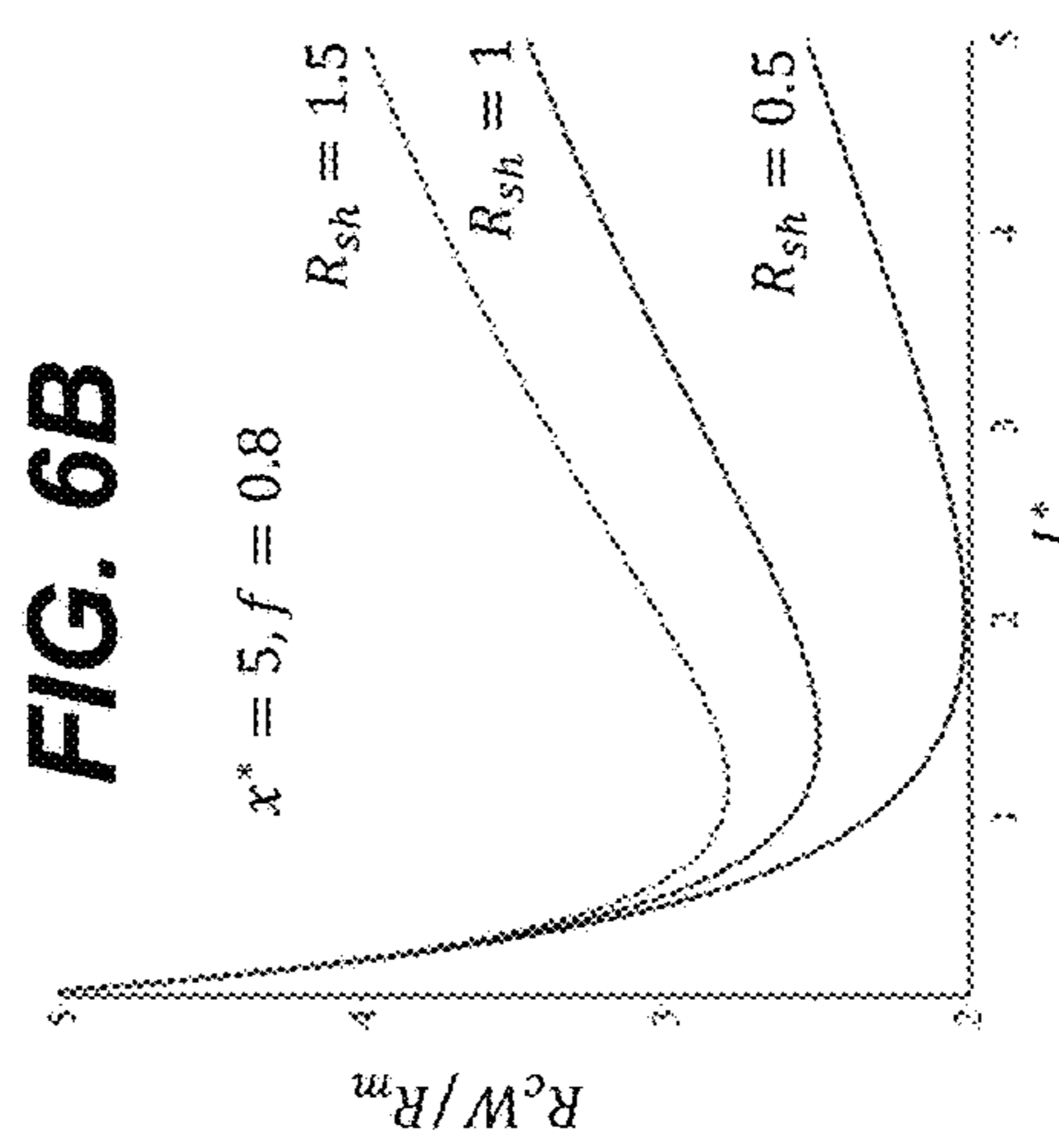
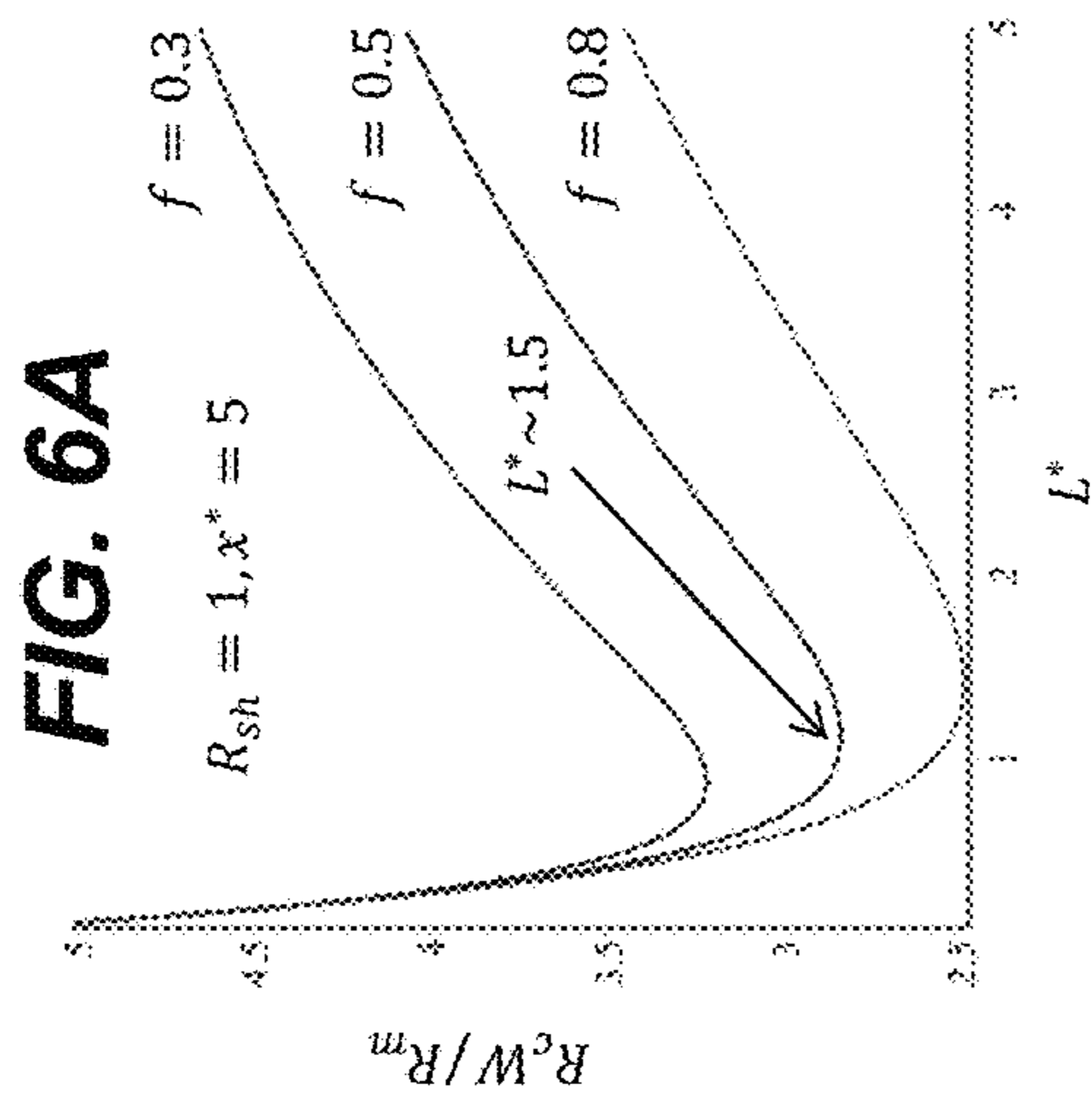

FIG. 7A

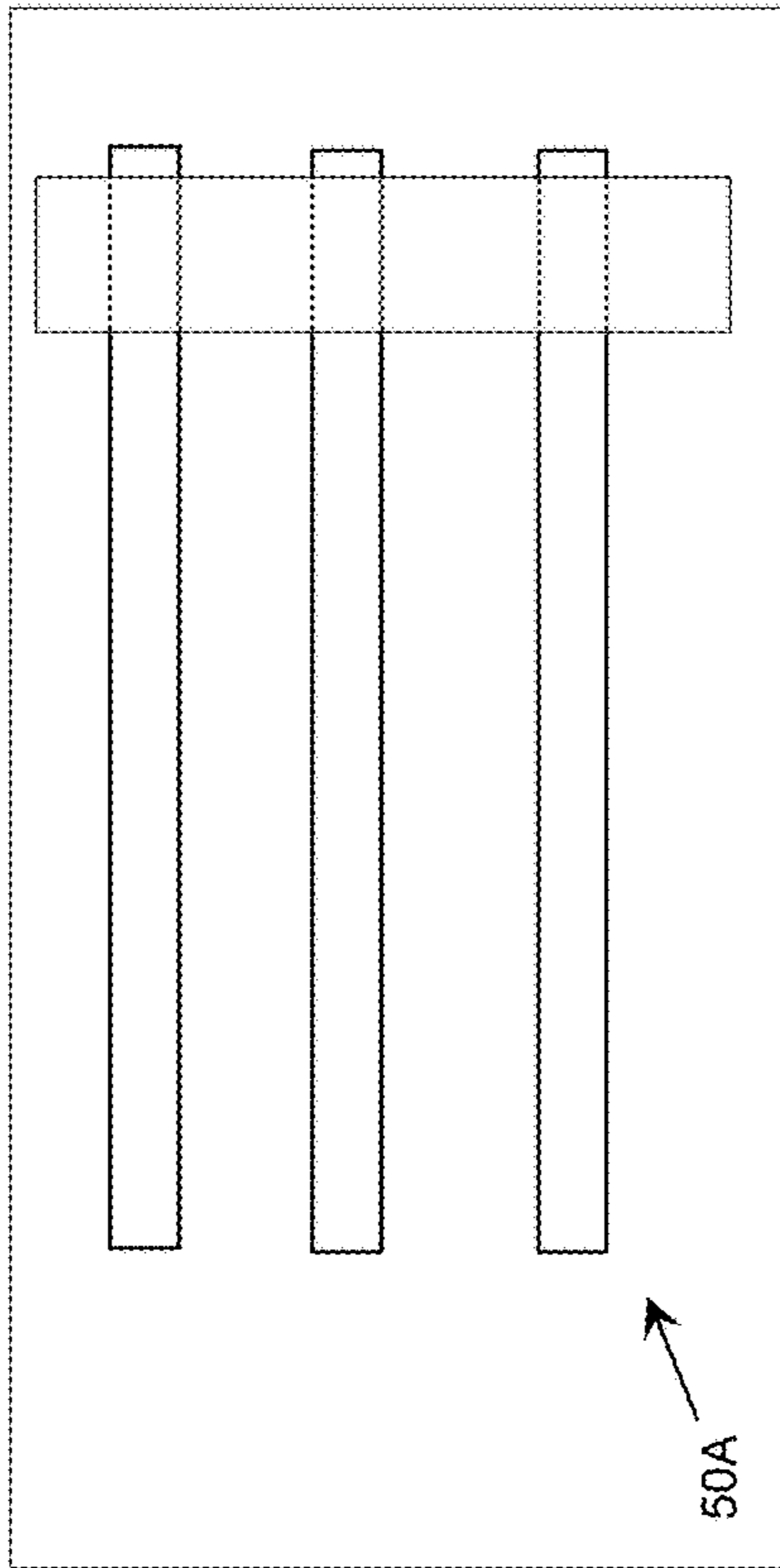

FIG. 7B

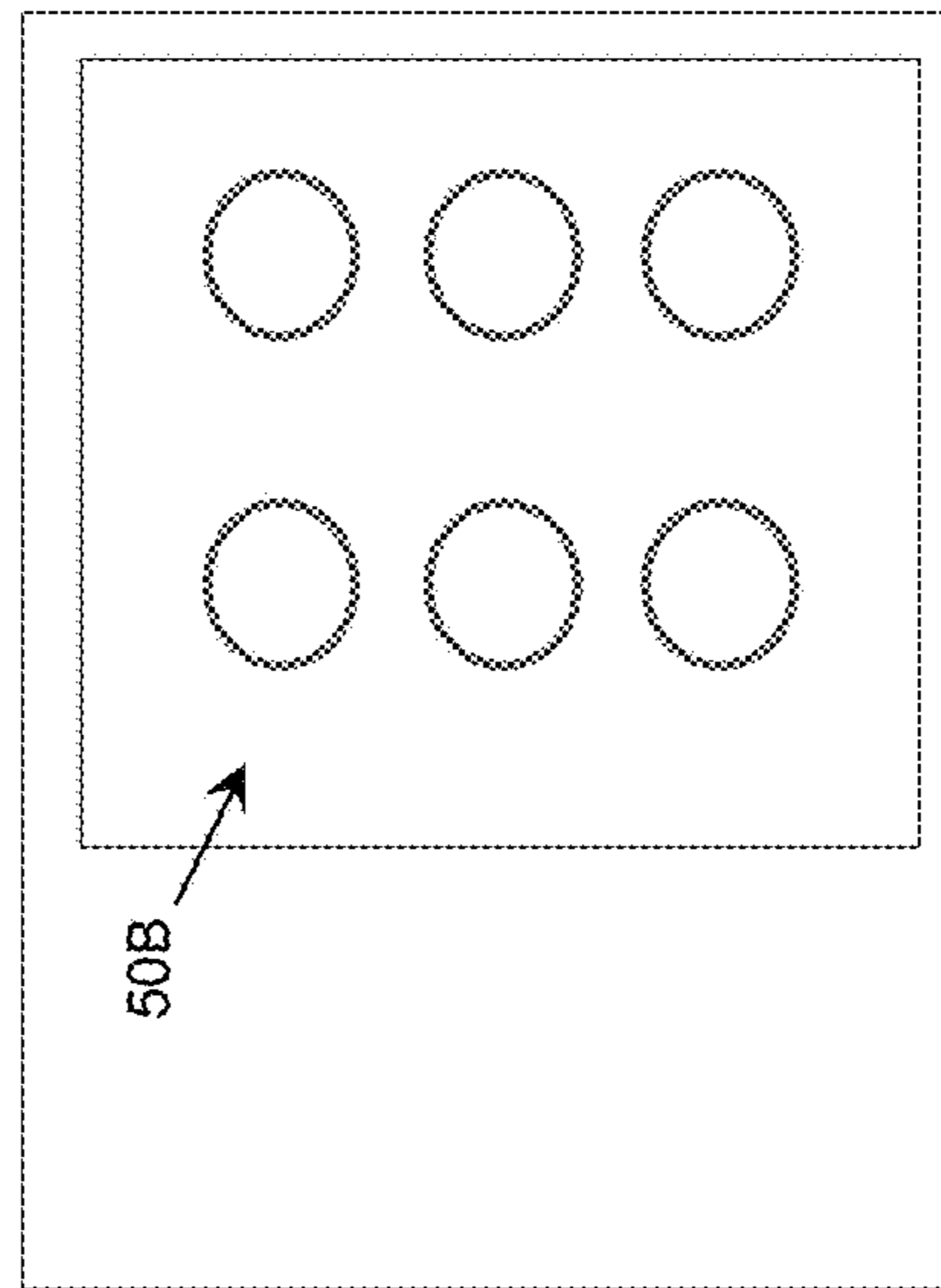

FIG. 7C

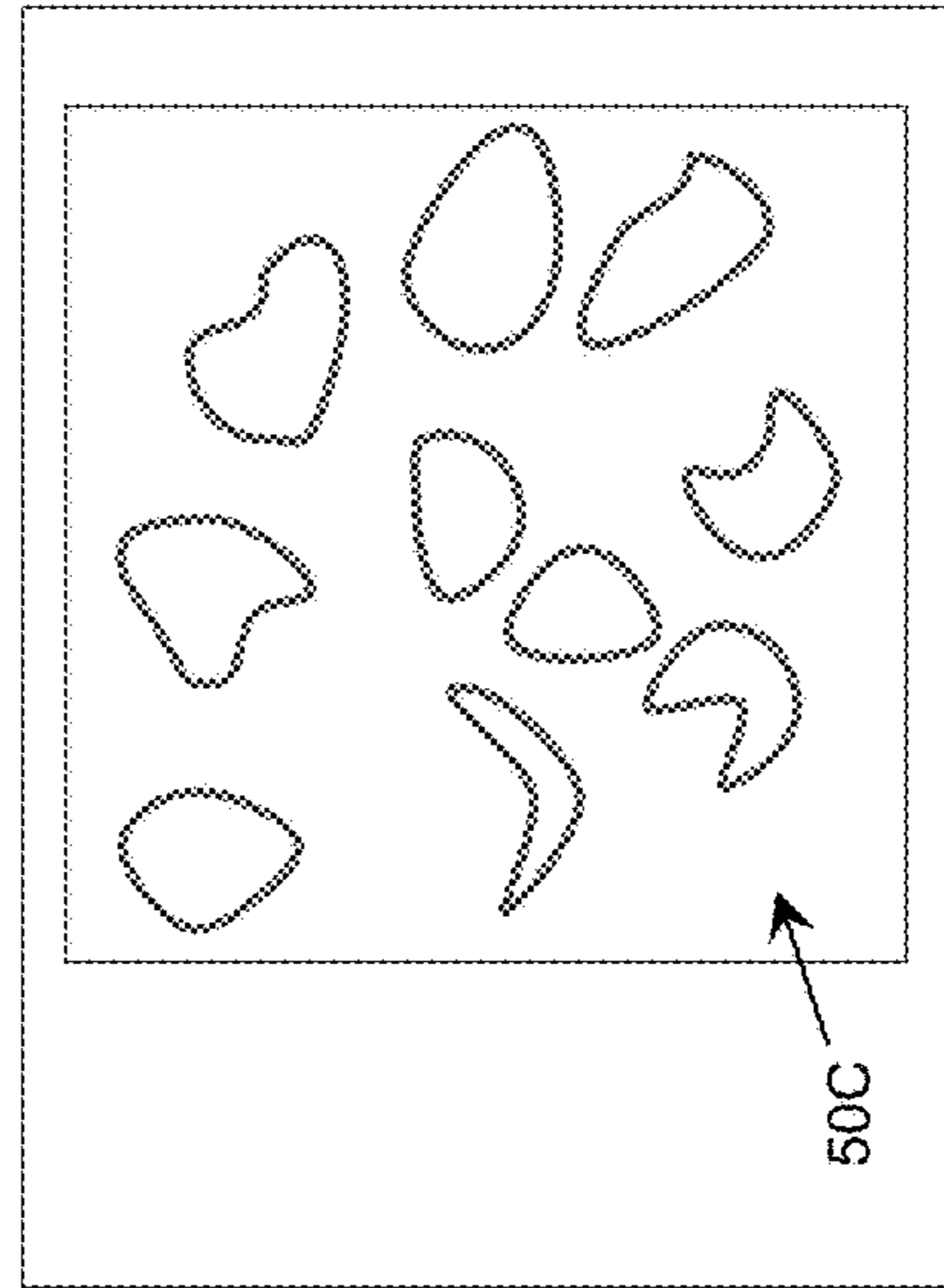

FIG. 8A

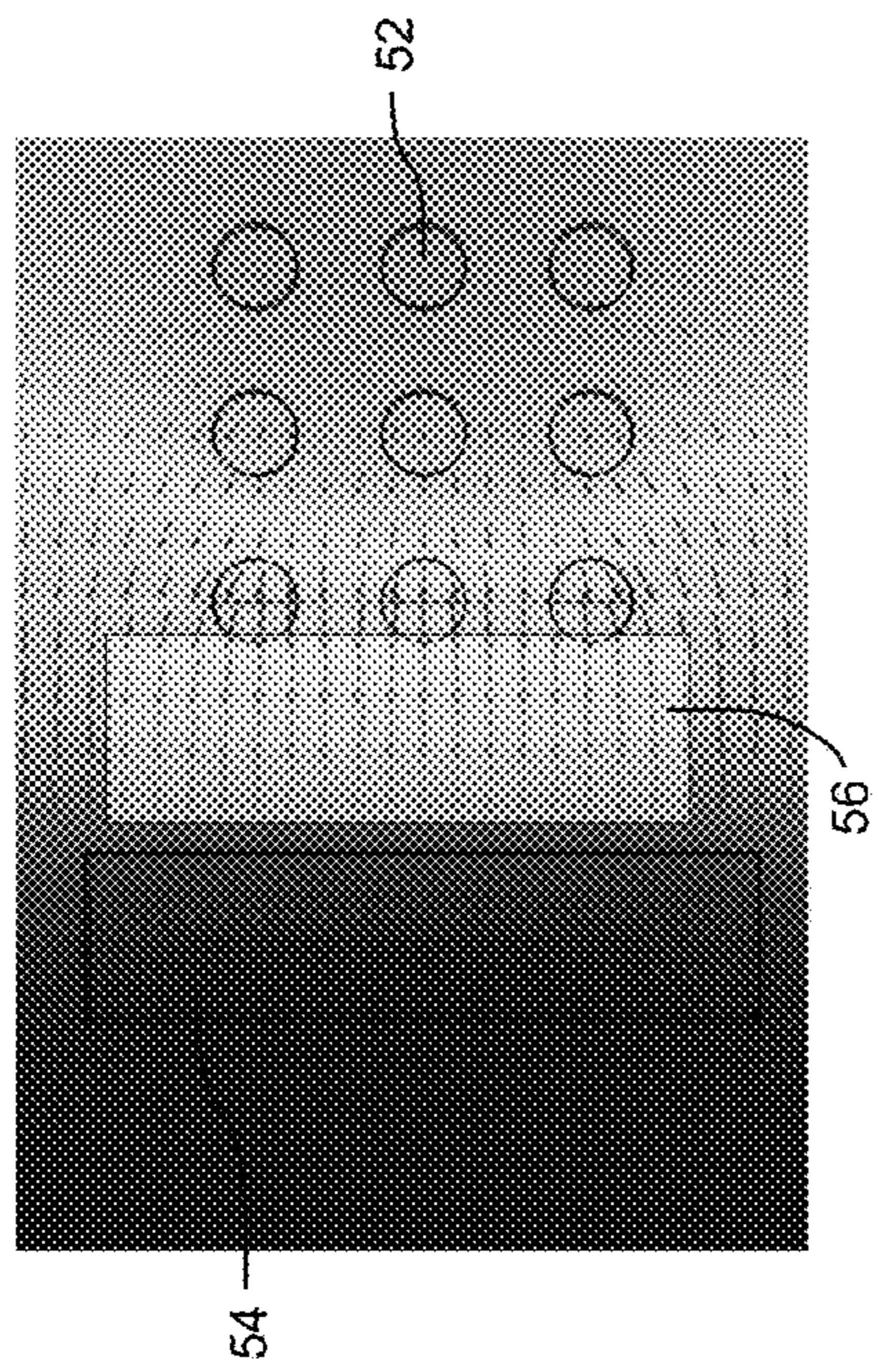

FIG. 8C

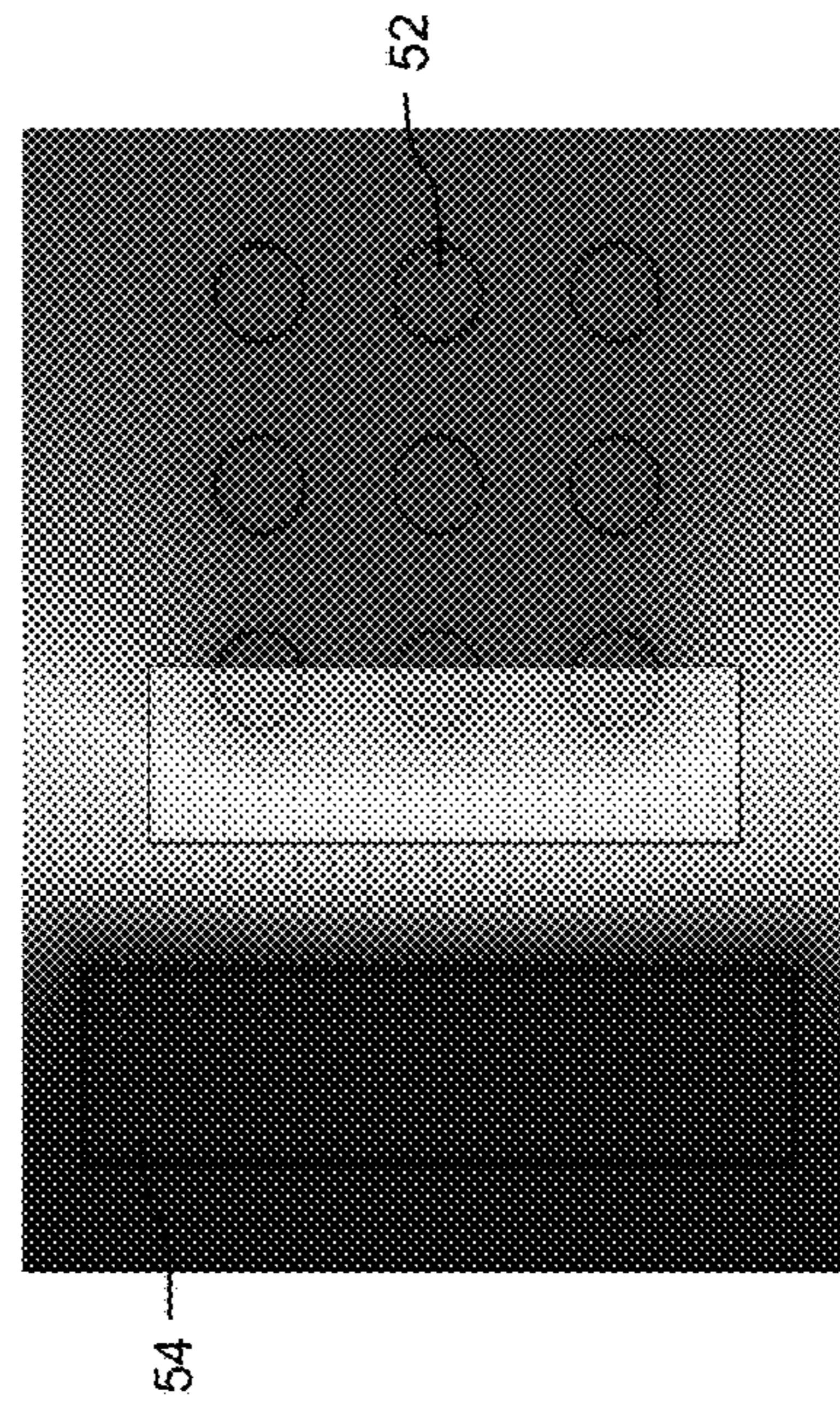

FIG. 8B

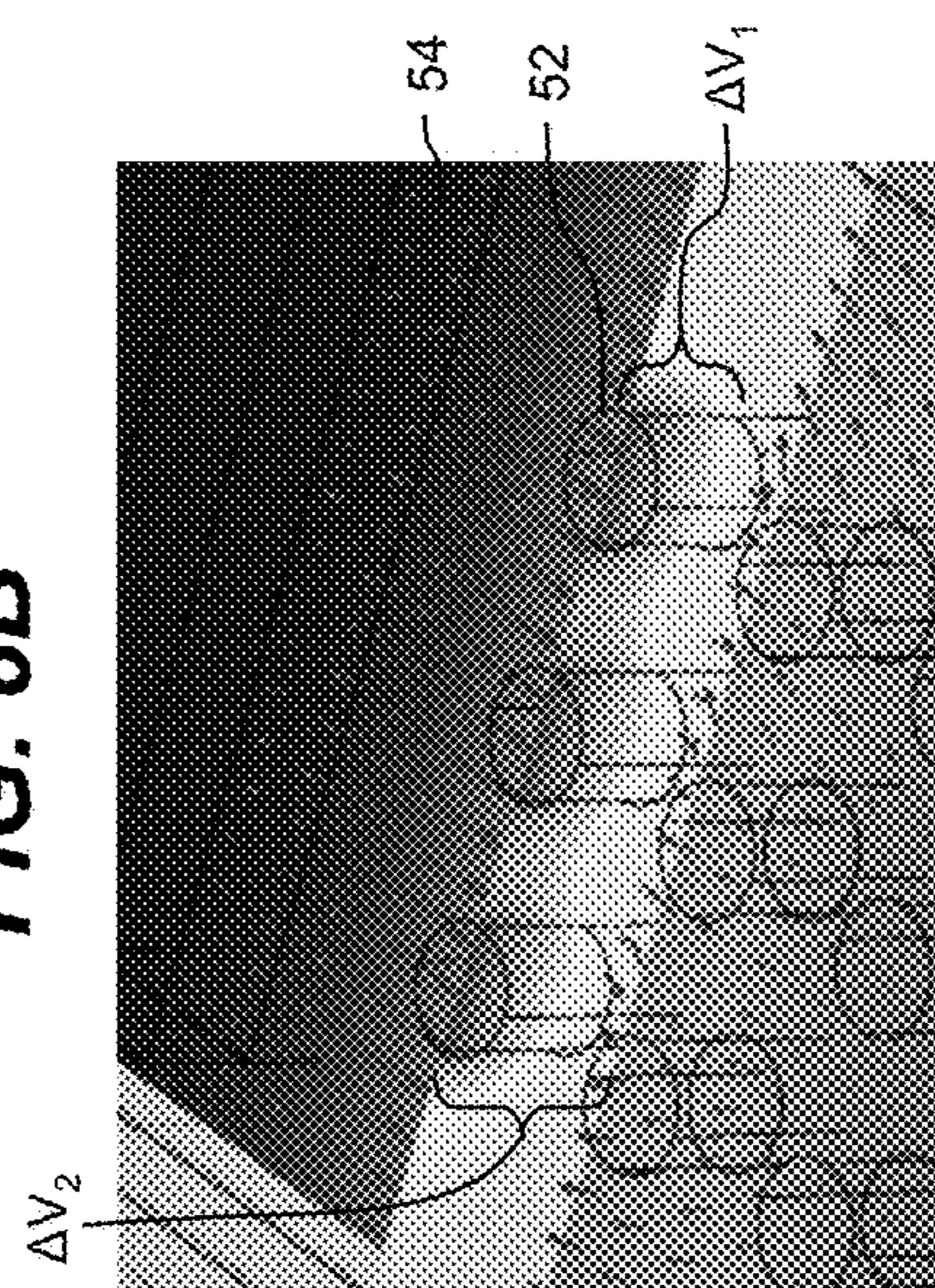

FIG. 9A

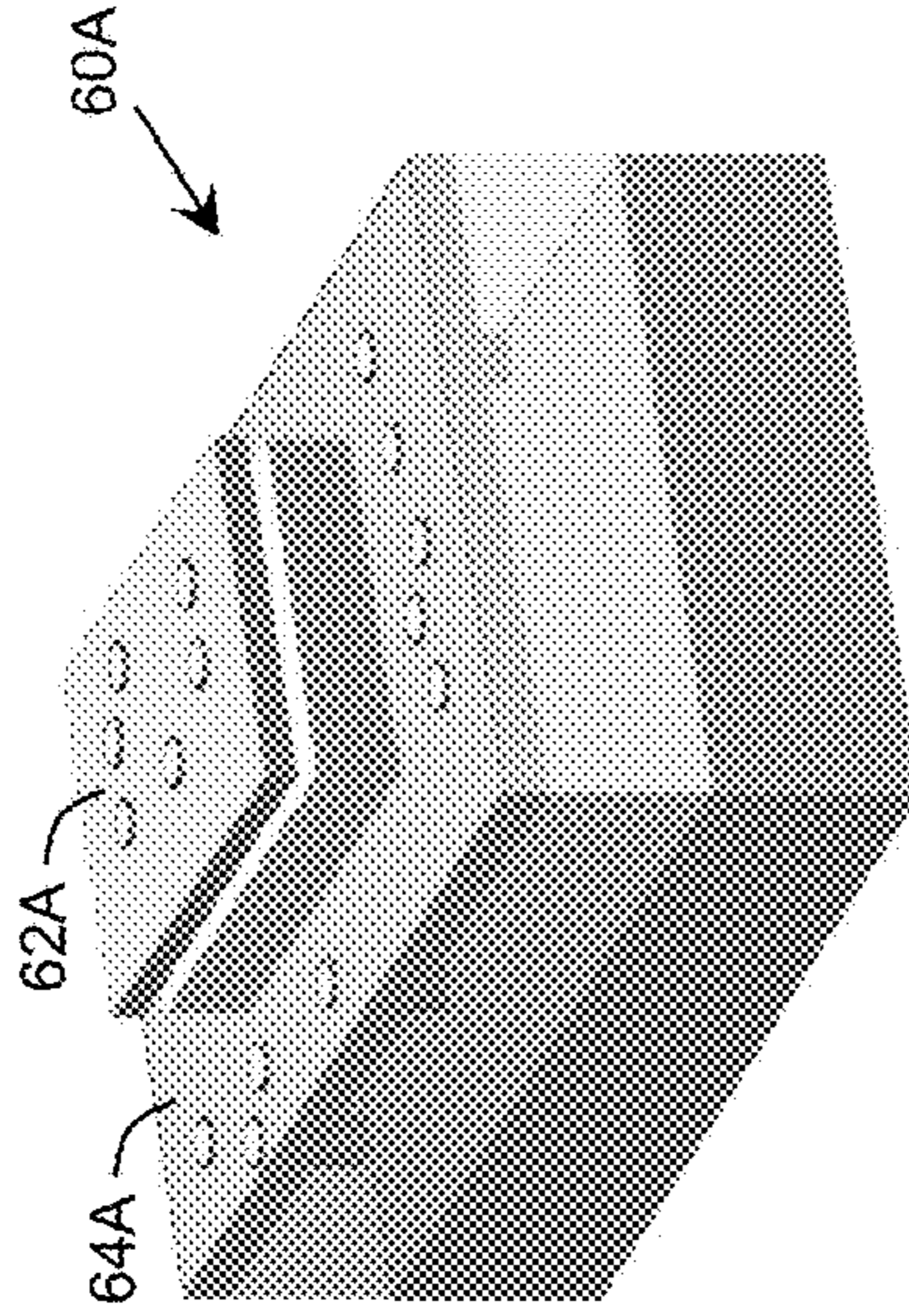

FIG. 9C

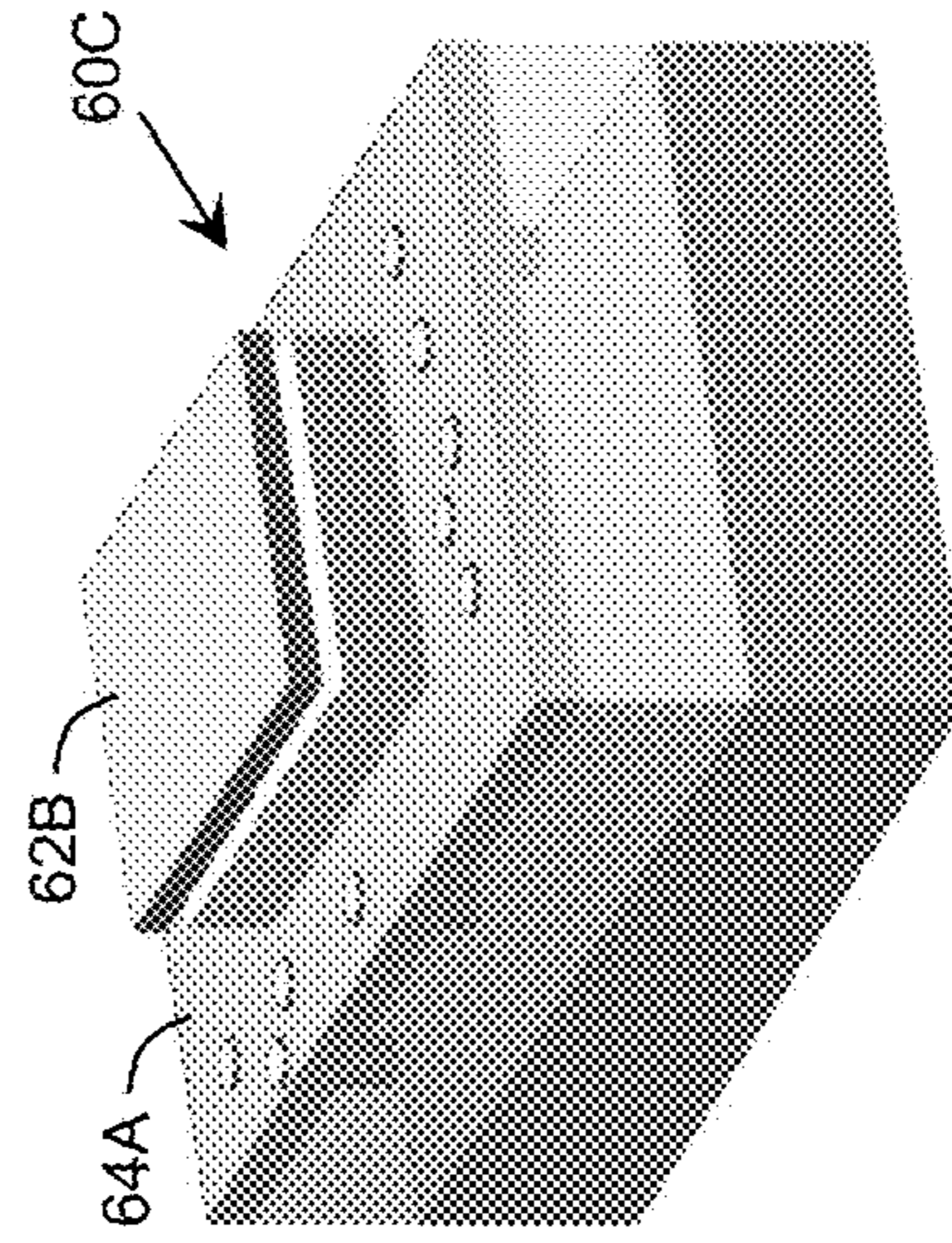

FIG. 9B

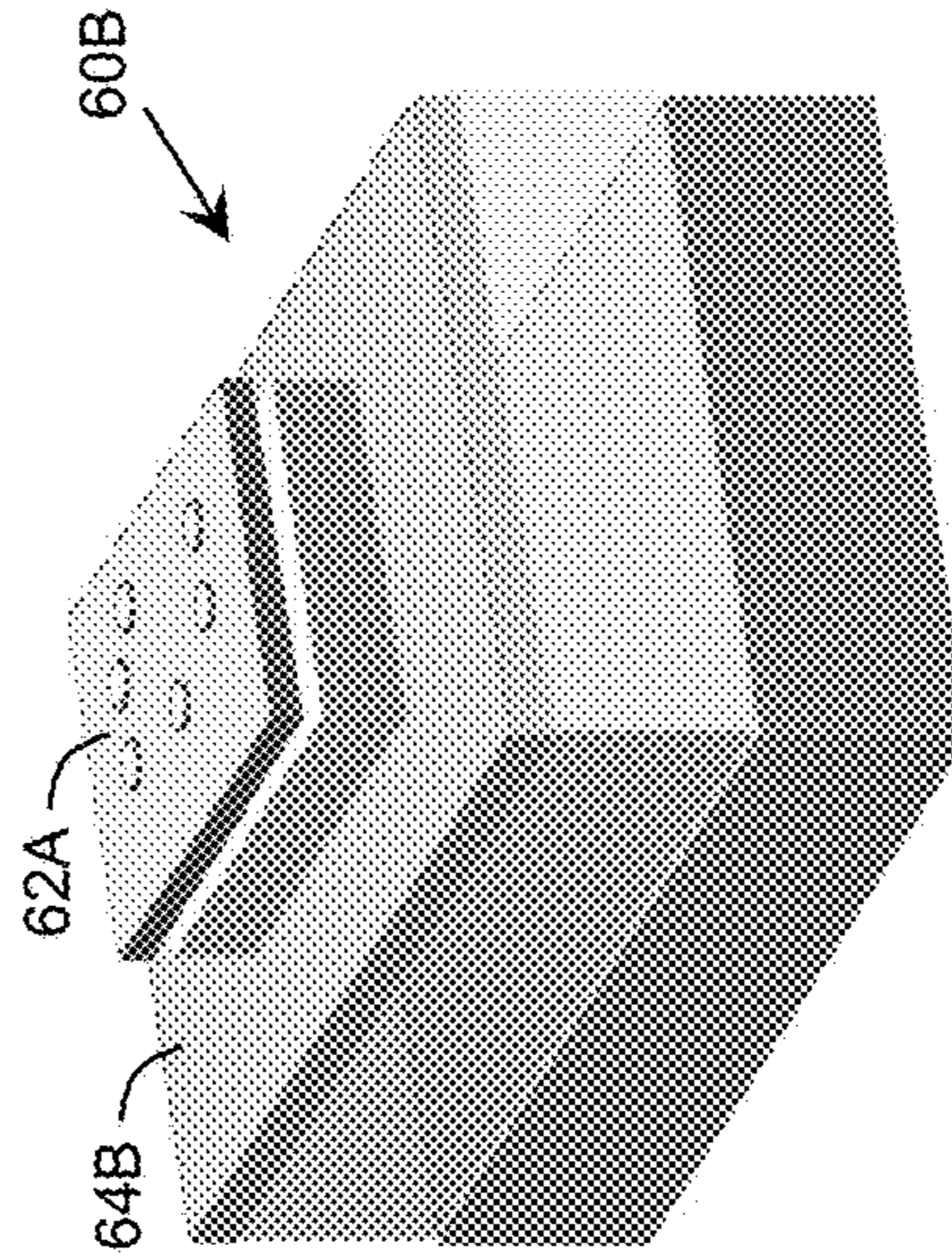

FIG. 10A

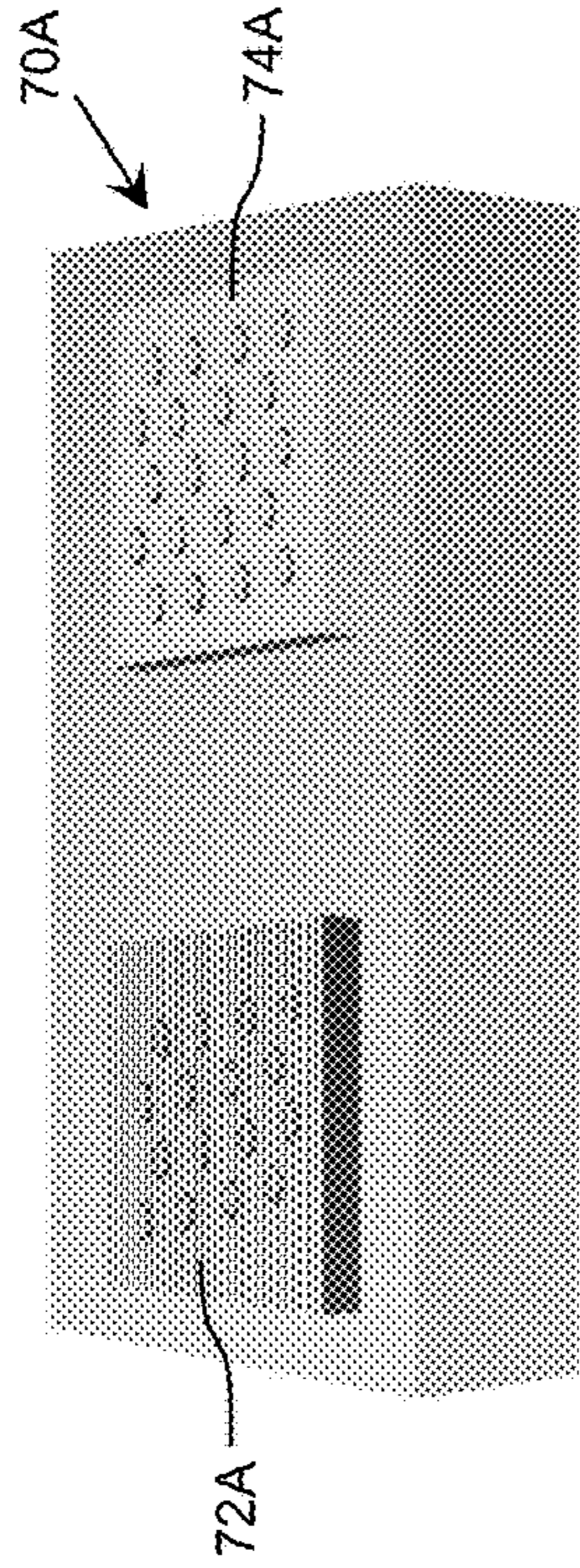

FIG. 10B

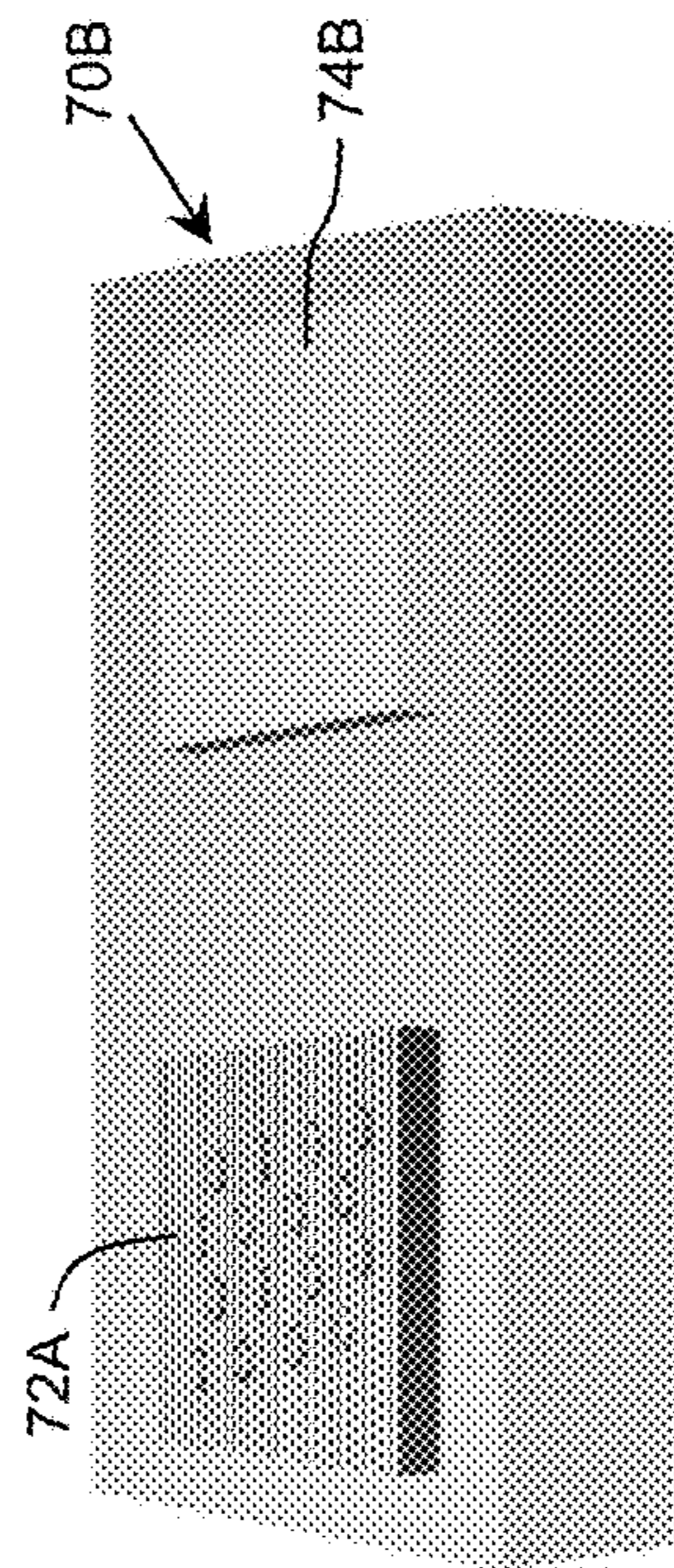

FIG. 10C

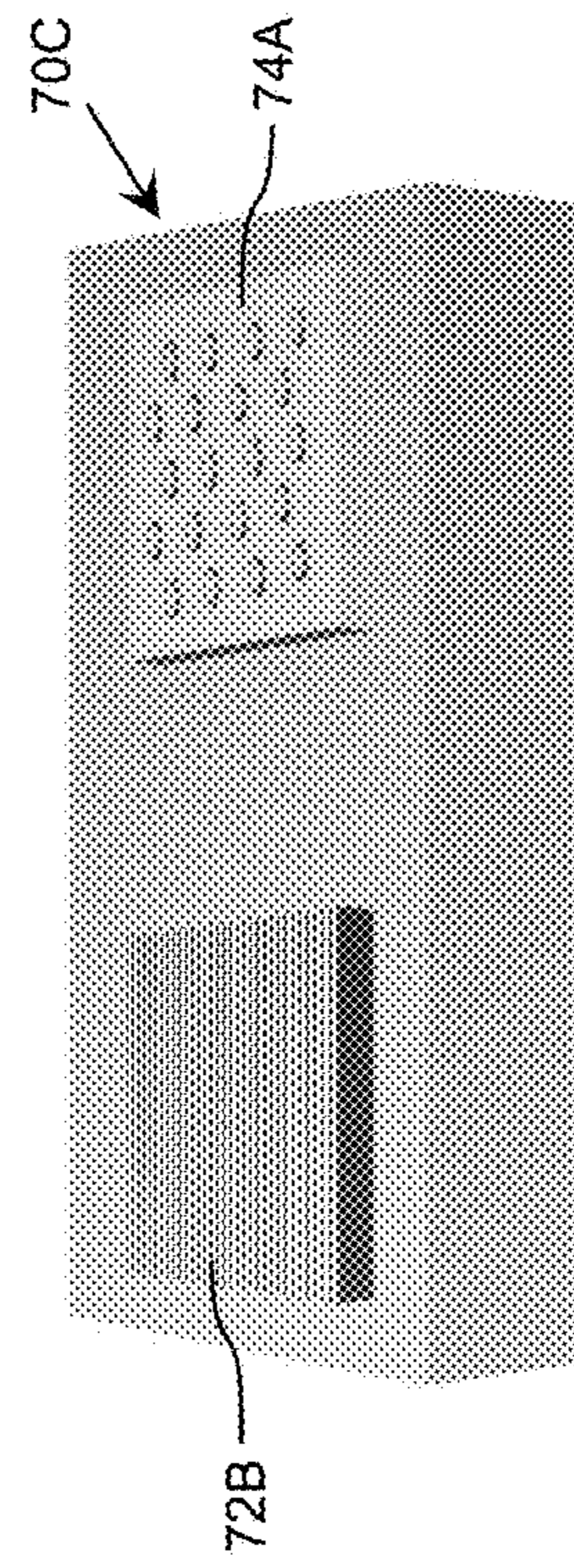

FIG. 11A

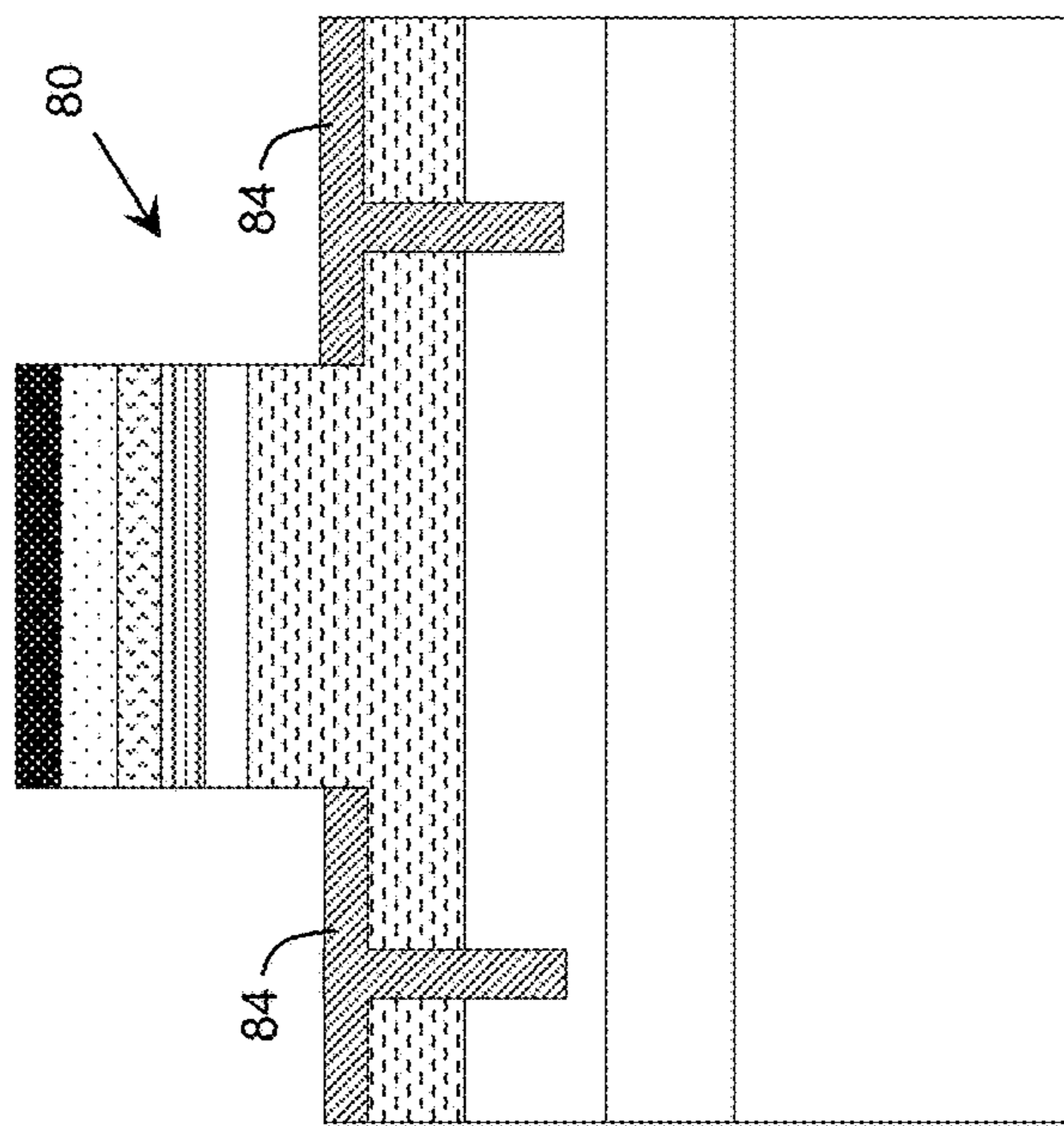

FIG. 11B

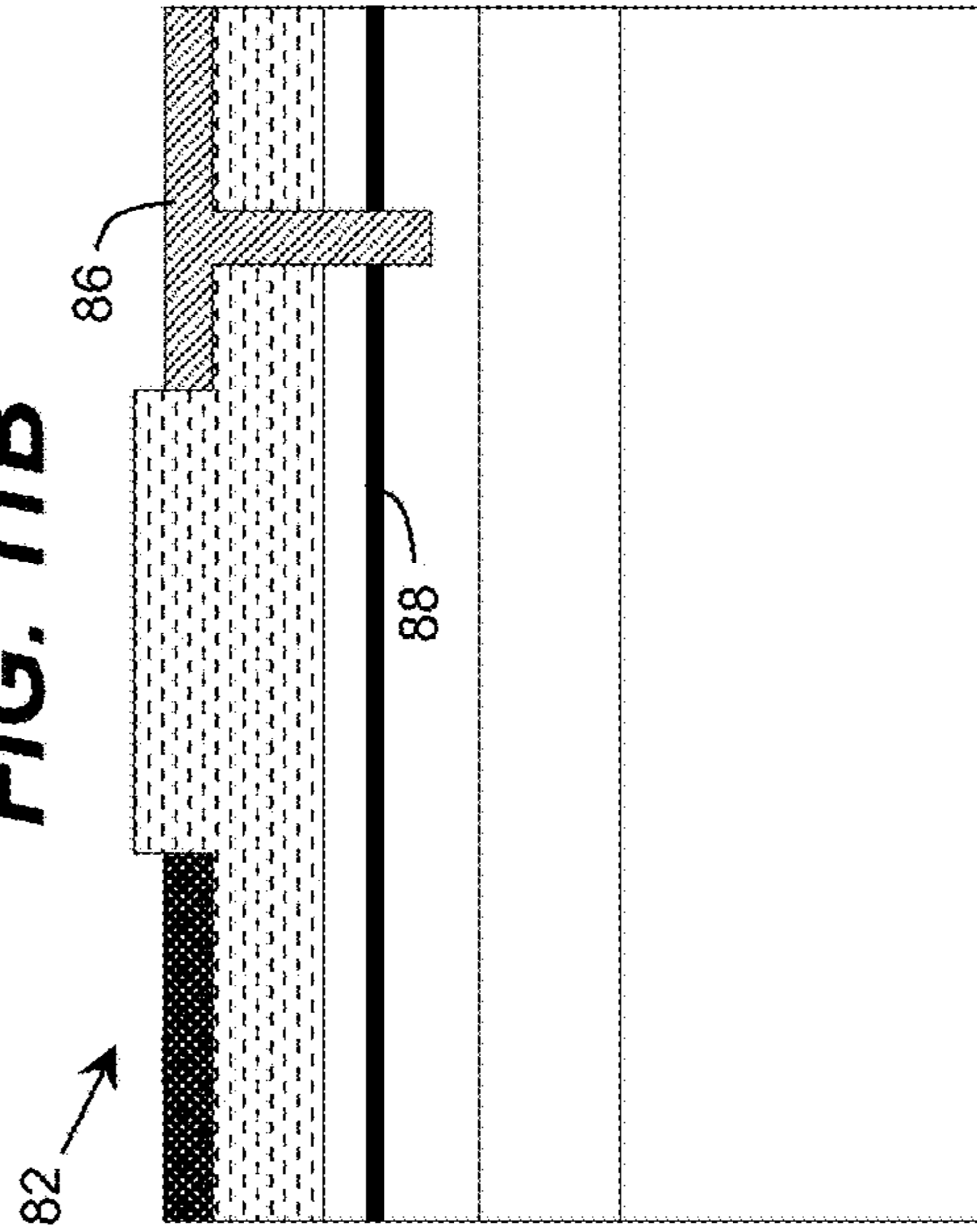

FIG. 12B

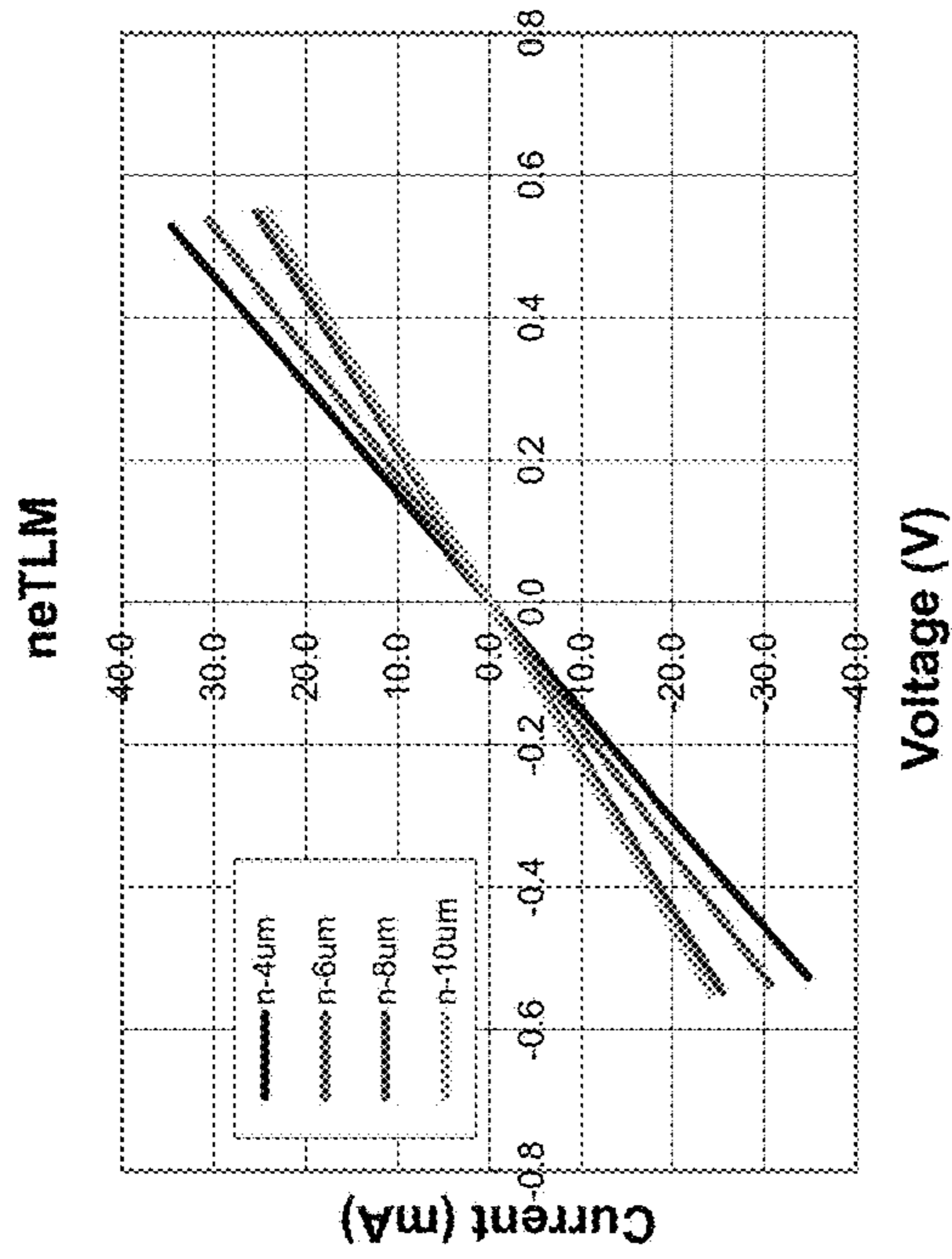

FIG. 12A

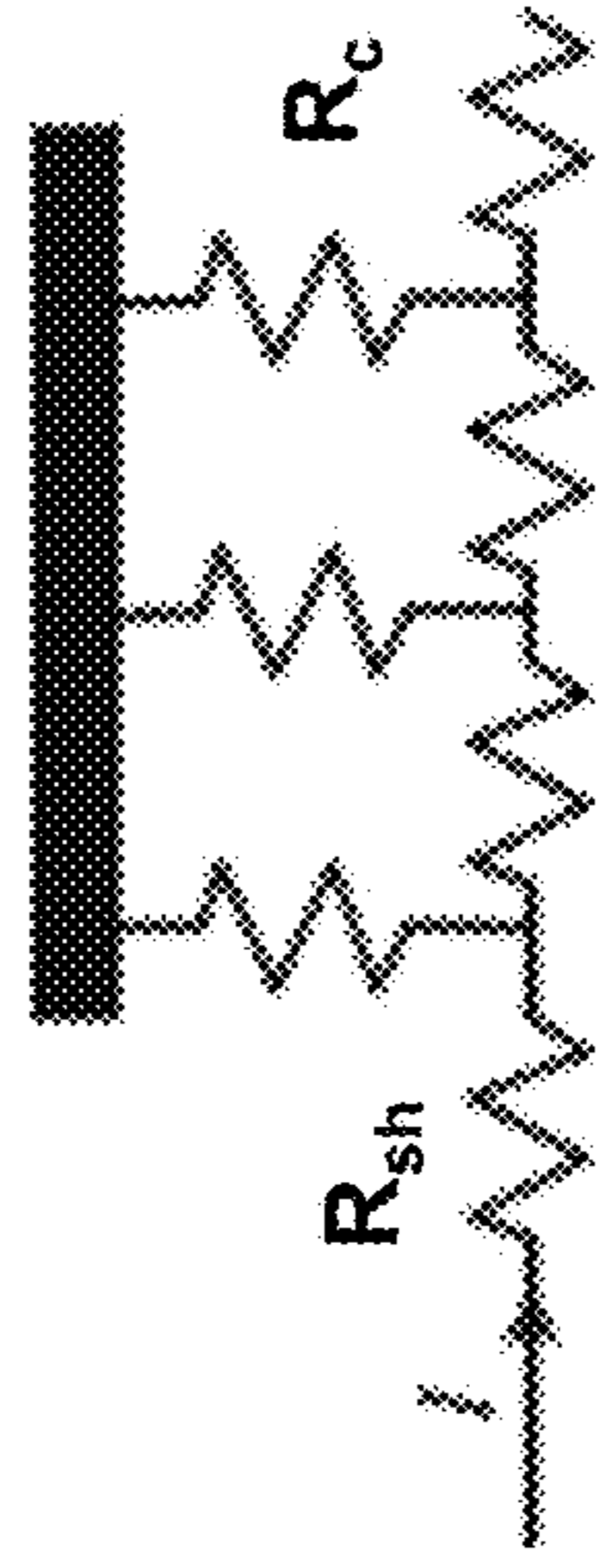

FIG. 12C

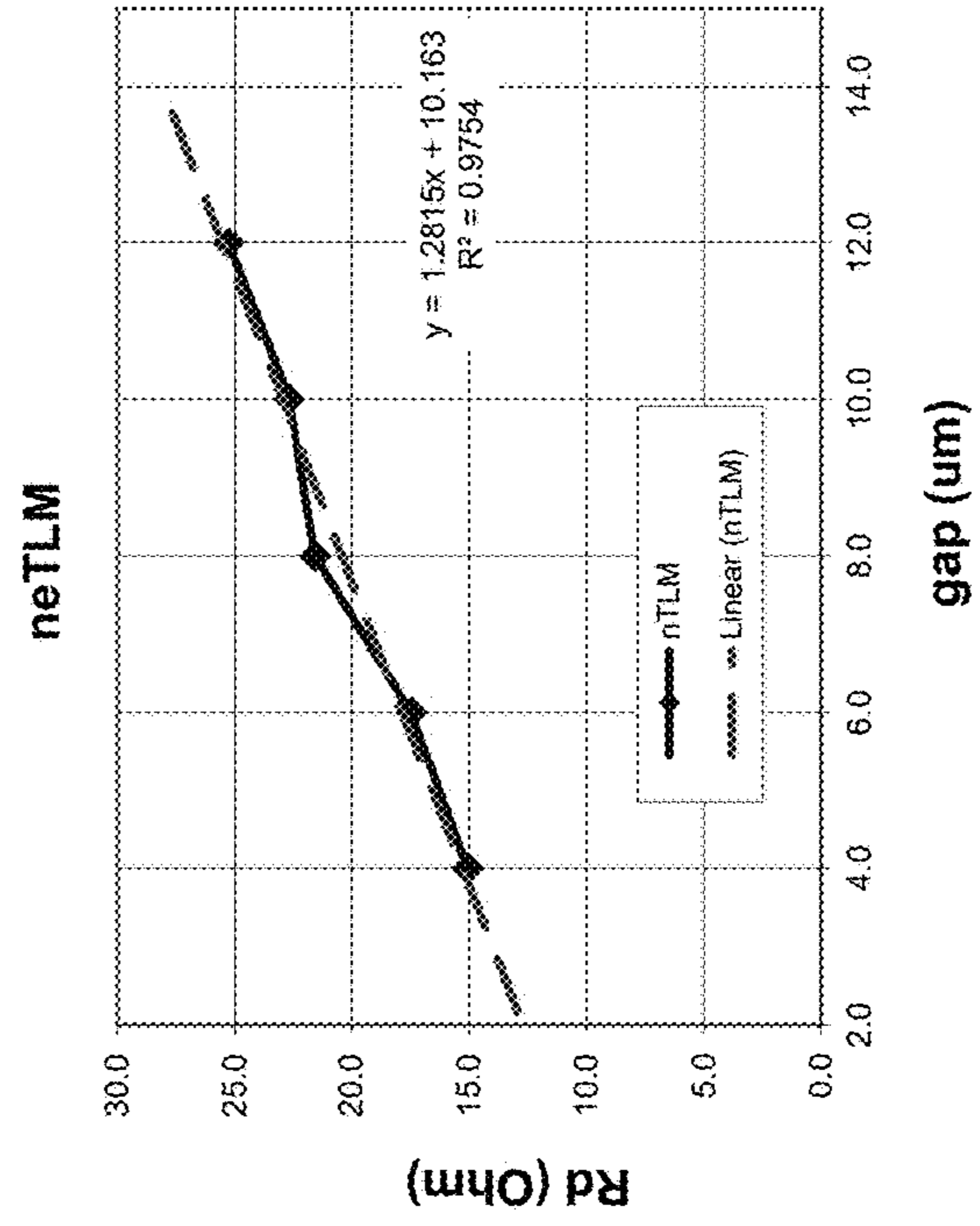

FIG. 12D

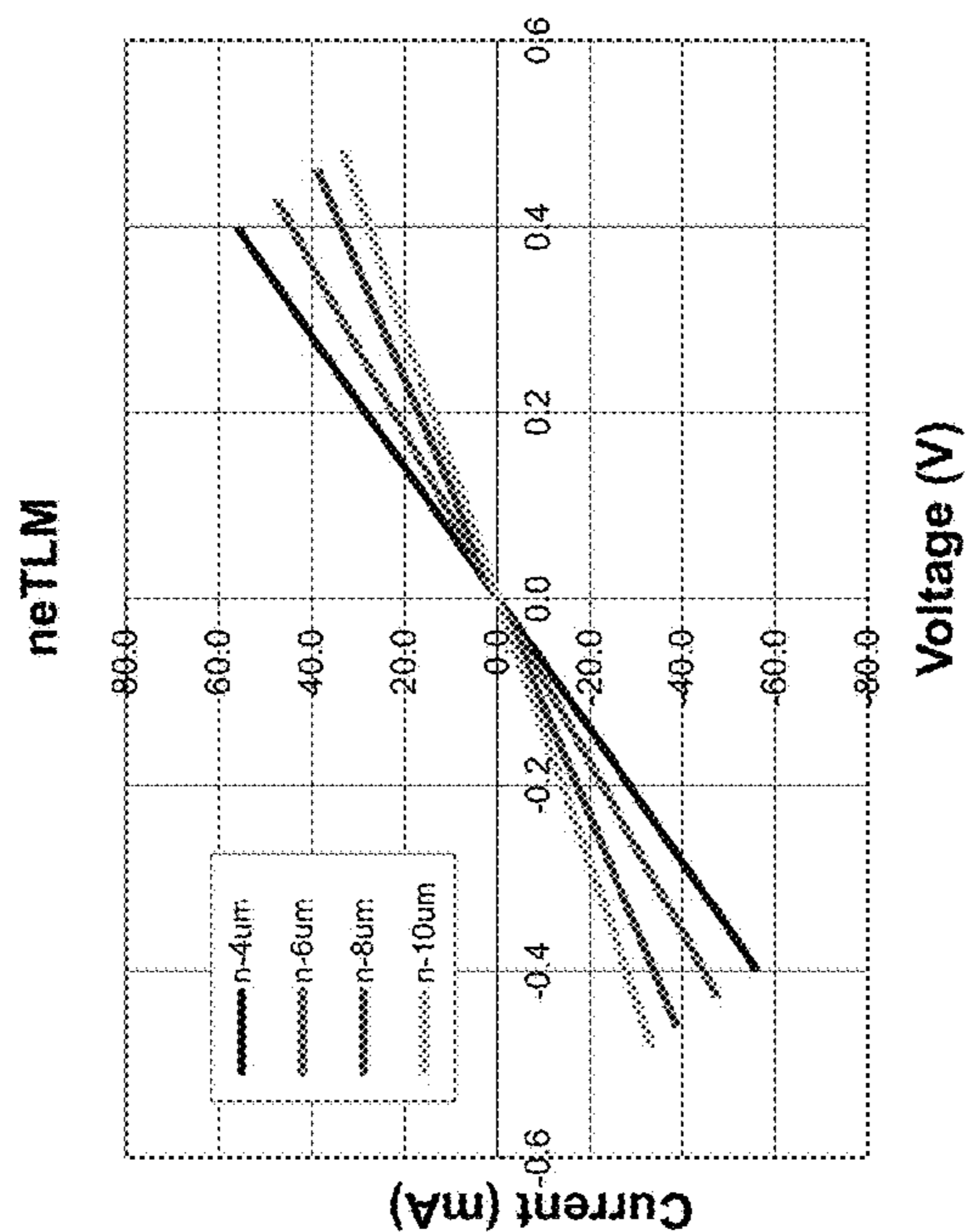

FIG. 12E

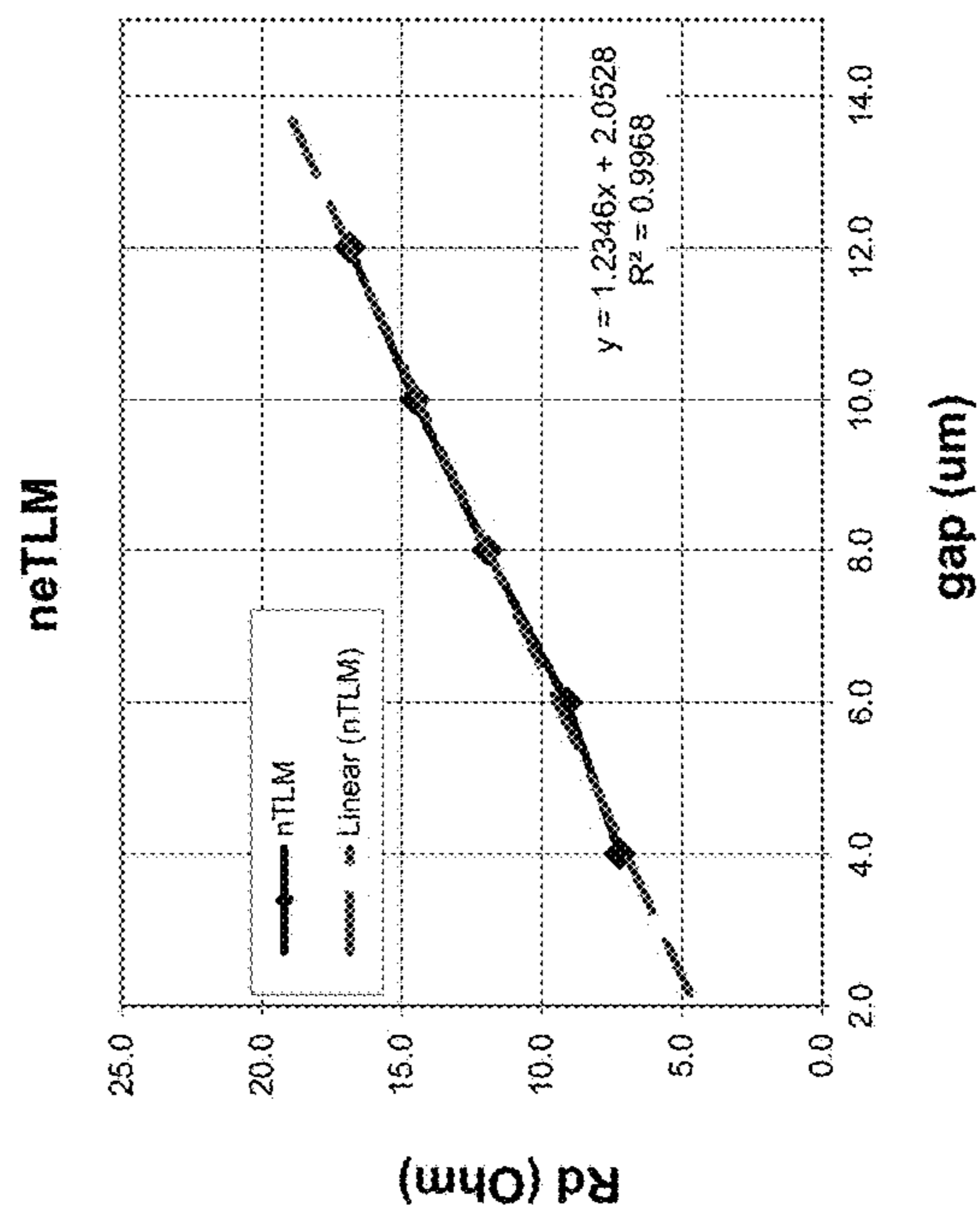
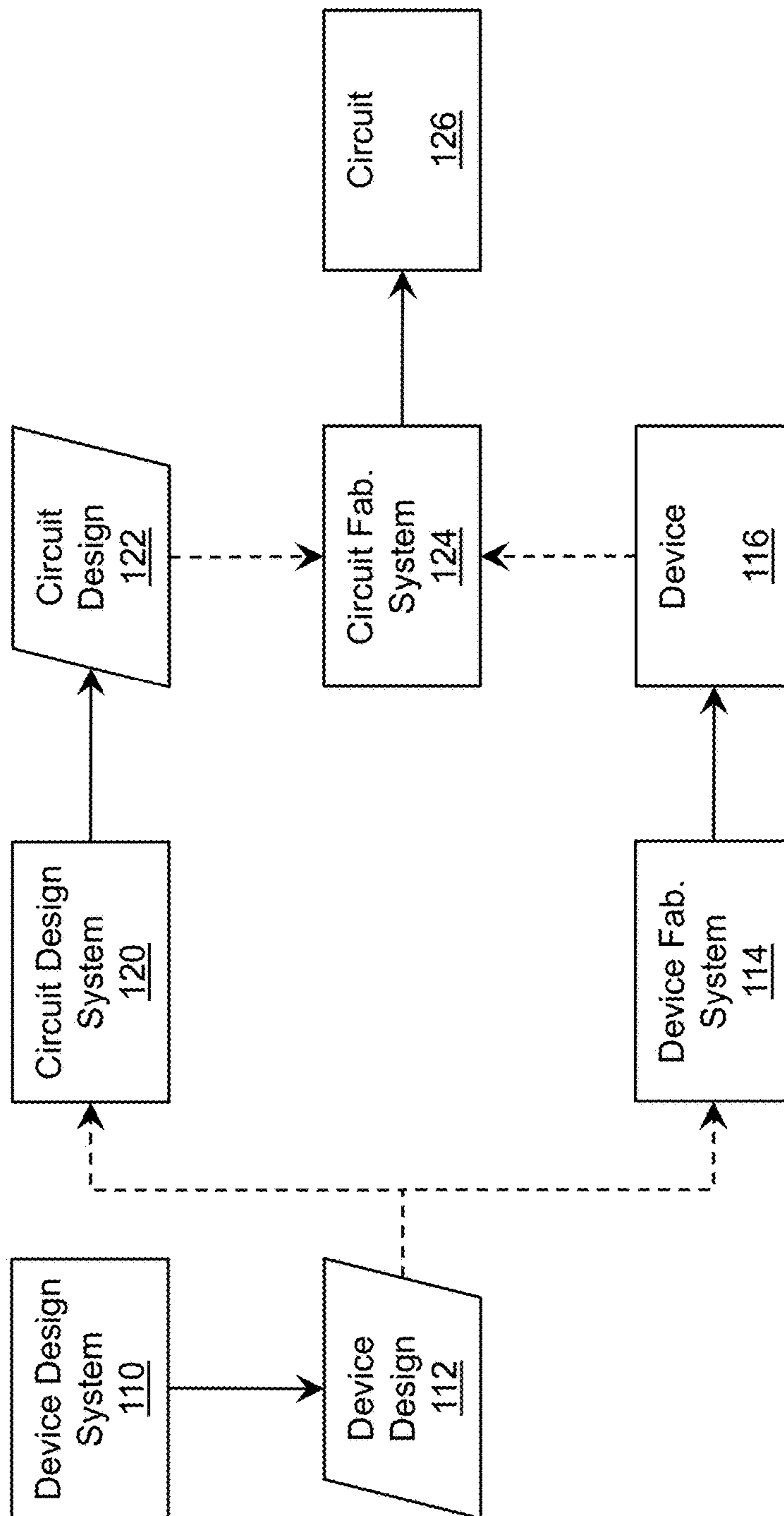

FIG. 13



PERFORATING CONTACT TO SEMICONDUCTOR LAYER

REFERENCE TO RELATED APPLICATIONS

The current application is a divisional of U.S. application Ser. No. 14/636,546, filed on 3 Mar. 2015, which is a continuation-in-part of U.S. application Ser. No. 13/909,621, filed 4 Jun. 2013, issued as U.S. Pat. No. 8,969,198 on 3 Mar. 2015, and claims the benefit of U.S. Provisional Application No. 61/655,437, filed on 4 Jun. 2012, each of which is hereby incorporated by reference.

TECHNICAL FIELD

The disclosure relates generally to ohmic contacts, and more particularly, to an improved method of manufacturing an ohmic contact to a semiconductor layer.

BACKGROUND ART

Developing a good ohmic contact to a semiconductor layer is critical for the operation, stability, and lifetime of the corresponding semiconductor device. Various approaches have been employed to form ohmic contacts. One approach, which can produce a good ohmic contact to a semiconductor layer, uses an annealing process. For example, titanium/aluminum (Ti/Al) is frequently used as an ohmic contact to n-doped nitride semiconductor layers. In this case, a titanium nitride (TiN) layer creates N vacancies in the underlying aluminum gallium nitride/gallium nitride (AlGaN/GaN) structure, which effectively dopes the material. Frequently, nickel (Ni) also is added to prevent diffusion and oxidation of the Ti/Al.

Another approach includes etching semiconductor layers and planting the ohmic contact into the etched cavity. For example, in one approach, recessed ohmic contacts are disclosed where a semiconductor device is formed by engineering a channel-forming layer grown on a semiconductor substrate with subsequent deposition of a Schottky layer. In this approach, the two dimensional electron gas (2DEG) is established at an interface between the Schottky layer and the channel-forming layer. Furthermore, in this approach, a gate electrode is formed on the Schottky layer via a cap layer and a recess-structured ohmic electrode is in ohmic contact with the 2DEG layer.

A similar technique has been used for Metal-Insulator-Semiconductor (MIS) high electron mobility transistors (HEMT). In this case, an insulating two nanometer thick AlN layer is removed and source and drain contacts are recessed. Contrary to the previous approach, the source and drain contacts are not recessed all the way to the 2DEG layer.

Recessed source and drain contacts also have been investigated in the context of transistor devices. Results have shown that a recessed source/drain structure can provide an ohmic contact with a much lower source/drain resistance than a conventional elevated source/drain contact. Furthermore, the recessed source/drain contact can reduce parasitic gate to source/drain capacitance over the conventional approach. A drawback of the recessed source and drain contacts is a presence of a short channel effect, which can deteriorate the device performance.

A recessed ohmic contact is useful as a way to access the 2DEG. A 2DEG is typically utilized in a HEMT, where the current path is formed at an interface between two types of semiconductor film having different band gaps. In order to

support the 2DEG, the semiconductor layers typically comprise a channel-forming layer formed on a substrate and another layer forming a heterojunction with the channel-forming layer. For example, a GaN film can be used as the channel-forming layer, and an AlGaN film can be used as the layer forming the heterojunction with the channel-forming layer.

A recessed ohmic contact also is beneficial in cases when semiconductor layers do not support 2DEG, such as an ohmic contact formed for a light emitting device (LED). In this case, the recessed ohmic contact allows for a larger contact-to-semiconductor junction area, and as a result, a lower contact resistance.

Other approaches to reduce the ohmic contact resistance for AlGaN/GaN based HEMTs, for example, utilize a highly doped n+ cap GaN layer or selective implantation of silicon (Si) near the source and drain contacts.

Approaches for forming ohmic contacts are very different for n- and p-type contacts. For n-type contacts to n-type GaN, for example, the ohmic contacts are formed using a metal work function that is smaller than that of the n-type GaN based semiconductor. A frequently used metal is Ti, which has a work function, $\phi_m=4.33$ eV. For Ti-based contacts to n-type GaN, which has a carrier concentration of 5 to $7 \times 10^{18} \text{ cm}^{-3}$, low contact resistances ranging from 10^{-5} to $10^{-8} \Omega\text{cm}^2$ have been obtained.

Making a p-type contact to p-type GaN, for example, is much more difficult. In particular, it is difficult to grow well doped p-type GaN with a carrier concentration of more than 10^{18} cm^{-3} due to a high activation energy of acceptors. Additionally, it is difficult to find metals with a work function that corresponds to p-type GaN. Metals with a large work function, such as Ni, are typically used to form ohmic p-type contacts. The details of annealing are an important factor for contact performance. Various annealing approaches have been proposed, including annealing in air or oxygen to improve contact performance. Other approaches to improve the performance of an ohmic contact include various methods of treating a semiconductor surface. The possible methods include plasma and laser treatment. In addition, use of superlattices, strained semiconductor layers, and spontaneous polarization have been employed to achieve a high hole concentration and result in a low contact resistivity.

SUMMARY OF THE INVENTION

Aspects of the invention provide a perforating ohmic contact to a semiconductor layer in a semiconductor structure. Other aspects provide an essentially linear perforating ohmic contact to a semiconductor layer in a semiconductor structure. The perforating ohmic contact can include a set of perforating elements, which can include a set of metal protrusions laterally penetrating the semiconductor layer(s). The perforating elements can be separated from one another by a characteristic length scale selected based on a sheet resistance of the semiconductor layer and a contact resistance per unit length of a metal of the perforating ohmic contact contacting the semiconductor layer. The structure can be annealed using a set of conditions configured to ensure formation of the set of metal protrusions.

A first aspect of the invention provides a method comprising: fabricating a perforating ohmic contact to a semiconductor layer in a semiconductor structure, the fabricating including: forming a plurality of cavities in the semiconductor structure, wherein the plurality of cavities are separated from each other by a characteristic length scale, and

wherein the characteristic length scale is selected based on a sheet resistance of the semiconductor layer and a contact resistance per unit length of a metal of the perforating ohmic contact contacting the semiconductor layer; depositing the metal into the plurality of cavities and over an area of the semiconductor structure including the plurality of cavities; and annealing the semiconductor structure and the metal using a set of conditions configured to ensure formation of a set of metal protrusions laterally penetrating the semiconductor layer from at least one of the plurality of cavities, wherein the set of metal protrusions are conducive to at least one of: field emission or field-enhanced thermionic emission.

A second aspect of the invention provides a device comprising: a semiconductor structure including a semiconductor layer; and a perforating ohmic contact to the semiconductor layer, the perforating ohmic contact including: a plurality of perforating elements formed of a metal deposited in a plurality of cavities in the semiconductor structure, wherein the plurality of cavities are separated from each other by a characteristic length scale selected based on a sheet resistance of the semiconductor layer and a contact resistance per unit length of the metal, and wherein at least one of the plurality of perforating elements includes a set of metal protrusions laterally penetrating the semiconductor layer conducive to at least one of: field emission or field-enhanced thermionic emission; and a top layer of the metal located over an area of the semiconductor structure including the plurality of cavities.

A third aspect of the invention provides a method of fabricating a device, the method comprising: forming a perforating ohmic contact to a semiconductor layer or a semiconductor structure, the perforating ohmic contact including: a plurality of perforating elements formed of a metal deposited in a plurality of cavities in the semiconductor structure, wherein the plurality of cavities are separated from each other by a characteristic length scale selected based on a sheet resistance of the semiconductor layer and a contact resistance per unit length of the metal, and wherein at least one of the plurality of perforating elements includes a set of metal protrusions laterally penetrating the semiconductor layer, wherein the set of metal protrusions are conducive to at least one of: field emission or field-enhanced thermionic emission; and a top layer of the metal located over an area of the semiconductor structure including the plurality of cavities.

The illustrative aspects of the invention are designed to solve one or more of the problems herein described and/or one or more other problems not discussed.

BRIEF DESCRIPTION OF THE DRAWINGS

These and other features of the disclosure will be more readily understood from the following detailed description of the various aspects of the invention taken in conjunction with the accompanying drawings that depict various aspects of the invention.

FIGS. 1A-1C show a portion of an illustrative device according to an embodiment.

FIGS. 2A-2E show shapes and scales of illustrative protrusions forming sharp edges according to embodiments.

FIGS. 3A and 3B show an illustrative perforating element in a semiconductor structure according to an embodiment.

FIG. 4 shows an illustrative geometrical model for calculating a resistance of a perforating ohmic contact according to an embodiment.

FIG. 5 shows an illustrative equivalent electrical circuit diagram of the geometrical model of FIG. 4 according to an embodiment.

FIGS. 6A-6C show dependence plots of normalized contact resistance on the contact length subject to various physical parameters according to an embodiment.

FIGS. 7A-7C show illustrative arrangements of perforating elements according to embodiments.

FIGS. 8A-8C show illustrative modeling of current flow and distribution of potential for an array of electrodes according to an embodiment.

FIGS. 9A-9C show illustrative light emitting diodes according to embodiments.

FIGS. 10A-10C show illustrative transistors according to embodiments.

FIGS. 11A and 11B show side views of an illustrative light emitting device and an illustrative transistor according to embodiments.

FIGS. 12A-12E illustrate the evaluation of the corresponding resistivities.

FIG. 13 shows an illustrative flow diagram for fabricating a circuit according to an embodiment.

It is noted that the drawings may not be to scale. The drawings are intended to depict only typical aspects of the invention, and therefore should not be considered as limiting the scope of the invention. In the drawings, like numbering represents like elements between the drawings.

DETAILED DESCRIPTION OF THE INVENTION

As indicated above, aspects of the invention provide a perforating ohmic contact to a semiconductor layer in a semiconductor structure. Other aspects provide an essentially linear perforating ohmic contact to a semiconductor layer in a semiconductor structure. A perforating ohmic contact described herein is “essentially linear” when the contact has a mostly (i.e., within $\pm 10\%$) linear dependence of current with applied voltage. As used herein, the terms “essentially linear” or “ohmic” are used to refer to perforating contacts having the mostly linear dependence of current with applied voltage. The perforating ohmic contact can include a set of perforating elements, which can include a set of metal protrusions laterally penetrating the semiconductor layer(s). The perforating elements can be separated from one another by a characteristic length scale selected based on a sheet resistance of the semiconductor layer and a contact resistance per unit length of a metal of the perforating ohmic contact contacting the semiconductor layer. The structure can be annealed using a set of conditions configured to ensure formation of the set of metal protrusions. As used herein, unless otherwise noted, the term “set” means one or more (i.e., at least one) and the phrase “any solution” means any now known or later developed solution.

A perforating ohmic contact described herein includes a plurality of perforating elements, which penetrate (e.g., are recessed into) one or more semiconductor layers located below the perforating ohmic contact. The perforating elements can have sharp edges, and when the perforating ohmic contact is to a two-dimensional carrier gas, the perforating elements can be sufficiently deep to penetrate the layers containing the two-dimensional carrier gas. In this manner, the perforating ohmic contact can provide a lower contact resistivity than a regular annealed contact and/or reduce current crowding in the device (e.g., high electron mobility transistor (HEMT), a light emitting diode (LED), and/or the like).

Turning to the drawings, FIGS. 1A-1C show a portion of an illustrative device **10** according to an embodiment. In particular, FIG. 1A shows a perspective view and FIG. 1B shows a top view of the device **10**. The device **10** includes a semiconductor structure **11** including semiconductor layer **12** and a second semiconductor layer **14**, and a two dimensional carrier (electron or hole) gas **16** formed at a hetero-junction of the layers **12**, **14**.

In an embodiment, the semiconductor structure **11** is a group III-V materials based semiconductor structure **11**, in which some or all of the various layers are formed of elements selected from the group III-V materials system. In a more particular illustrative embodiment, the various layers of the semiconductor structure **11** are formed of group III nitride based materials. Group III nitride materials comprise one or more group III elements (e.g., boron (B), aluminum (Al), gallium (Ga), and indium (In)) and nitrogen (N), such that $B_W Al_X Ga_Y In_Z N$, where $0 \leq W, X, Y, Z \leq 1$, and $W+X+Y+Z=1$. Illustrative group III nitride materials include binary, ternary and quaternary alloys such as, AlN, GaN, InN, BN, AlGaInN, AlInN, AlBN, AlGaInN, AlGaBN, AlInBN, and AlGaInBN with any molar fraction of group III elements.

The device **10** also is shown including a perforating ohmic contact **20**. The contact **20** includes a metallic layer **22** and a plurality of perforating elements **24** (e.g., recessed electrodes). As illustrated, the plurality of perforating elements **24** extend entirely through the layer **14** and the two-dimensional carrier gas **16** and at least partially extend into the layer **12**. The metallic layer **22** connects at least a portion of the plurality of perforating elements **24** to one another. As a result, the layer **22** and the perforating elements **24** together form the perforating ohmic contact **20**. While aspects of the invention are described in conjunction with a pair of layers **12**, **14** and a two-dimensional carrier gas **16** formed there between, it is understood that the semiconductor structure **11** can include any number of layers between the metallic layer **22** and the layer **14**. These layer(s) can be configured to provide any desired functionality during operation of the corresponding device **10**, including for example, a layer of low conductive material, an isolating layer of material, a barrier layer, a passivation layer, a protective coating, a reflective coating, an antireflective coating, and/or the like.

FIG. 1C shows a more detailed view of a perforating element **24** according to an embodiment. As illustrated, the perforating element **24** has a perimeter **30** that is generally not smooth can includes a set of sharp edges **32**. The sharp edges **32** can lead to an increased conductance and an overall improvement in the performance of the perforating ohmic contact **20**. As described herein, the perimeter **30** including the sharp edges **32** can be formed from a set of metal protrusions (bulges) laterally extending from the perforating element **24** and penetrating a corresponding semiconductor layer (e.g., layers **12**, **14** of FIG. 1A). These metal protrusions can make the perimeter **30** a complex shape and increase the periphery of the perforating element **24**.

FIGS. 2A-2E show shapes and scales of illustrative protrusions **34A-34D** forming sharp edges according to embodiments. In particular, FIGS. 2A-2D shows illustrative protrusions **34A-34D**, including a frustum **34A** (resembling a cone), a rectangular frustum **34B** (resembling a pyramid), a rectangular frustum **34C** having sloping sides, and a triangular prism **34D**. However, it is understood that these are only illustrative shapes for protrusions **34A-34D**, and a protrusion can have any geometric shape, including any complex and/or irregular geometric shape.

As shown in FIG. 2E, a protrusion, such as the protrusions **34E**, **34F** shown therein, can comprise a side bulge from a perforating element **24E**. In an embodiment, a protrusion can have a bottom base, which is adjacent to the corresponding perforating element **24E**, and a top base, which is at an end located furthest from the corresponding perforating element **24E** in the semiconductor layer. In this case, the top base can have a cross section that is smaller than a cross section of the bottom base. Furthermore, a characteristic lateral size of the protrusion can be greater than or equal to one half of the Bohr radius in the corresponding semiconductor layer and/or the two-dimensional carrier gas region. Additionally, the characteristic lateral size of the protrusion can be less than a characteristic length scale separating the perforating element **24E** from one or more adjacent perforating elements.

Returning to FIGS. 1A-1C, the device can be fabricated using any solution. Initially, the semiconductor structure **11** can be fabricated using any solution. For example, the semiconductor structure **11** can comprise a group III nitride based heterostructure. In this case, fabrication of the semiconductor structure can include: growing an AlN buffer layer on a substrate, such as sapphire; growing an GaN layer **12** above the buffer layer; and growing an AlGaIn layer **14** above the GaN layer **12**. In this case, the semiconductor layer **12** having a high gallium content is capped with a layer of high aluminum content to form the two-dimensional carrier gas **16** at the heterojunction of the layers **12**, **14**. As described herein, the two-dimensional carrier gas **16** can comprise an electron gas or a hole gas. In general, all aspects of the invention described herein are applicable to both two-dimensional electron and hole gases.

Subsequently, the perforating ohmic contact **20** can be formed. To this extent, a plurality of cavities can be formed in the semiconductor structure **11**, e.g., using an etching process. The plurality of cavities can have a depth that is deeper than a thickness of the semiconductor layer **14**, thereby obtaining access to the two-dimensional carrier gas **16**. A typical depth of the cavities can be few tens of nanometers. The plurality of cavities can be formed in any pattern and spacing. In an embodiment, the plurality of cavities are separated from each other by a characteristic length scale. The characteristic length scale can be selected based on a sheet resistance of the semiconductor layer **14** and a contact resistance per unit length of a metal to be used for the perforating ohmic contact **20**. In an embodiment, the plurality of cavities are formed using a multi-step etching process. For example, plasma assisted etching can be used during a first etching step, which is followed by wet etching during a second etching step. Wet etching can utilize, for example, hydrofluoric acid, which can selectively etch along grain boundaries, dislocations, and other lattice defects, resulting in a non-uniform and complex etched relief. Such a relief can promote formation of an increased number of electrode protrusions during subsequent formation of the perforating ohmic contact **20**.

After formation of the cavities, a metal for the perforating ohmic contact **20** can be deposited into the cavities to form the plurality of perforating elements **24** and over an area of the semiconductor structure **11** including the cavities to form the metallic layer **22** using any solution. Depending on a type of ohmic contact desired, different metals can be chosen for the perforating ohmic contact **20**. For example, titanium/aluminum (Ti/Al) can be used to form a perforating ohmic contact **20** to an n-doped nitride semiconductor layer. For a p-type perforating ohmic contact **20**, a metal with a larger work function, such as nickel and/or palladium can be used.

Subsequently, the semiconductor structure **11** and metal can be annealed. The annealing can be performed using a set of conditions configured to ensure formation of a set of metal protrusions laterally penetrating the semiconductor layer **14** from the perforating elements **24**. In an embodiment, the set of annealing conditions includes a temperature less than or equal to 850 degrees Celsius for forming a metal contact to a group III nitride semiconductor layer. In a more particular embodiment, the annealing includes rapid thermal annealing lasting for about a minute at about 600 degrees Celsius, followed by four to eight minute annealing at about 400 degrees Celsius. The annealing can be carried in an N₂ atmosphere.

In an embodiment, the annealing is configured to control a complexity and/or direction of the metal protrusions extending from a perforating element **24**. For example, use of a relatively high temperature rapid annealing, where temperatures can reach up to approximately 850 degrees Celsius for a duration of less than a minute, can result in metal protrusions that extend laterally throughout the two dimensional carrier gas. In a more particular embodiment, rapid annealing lasting approximately forty-five seconds was used to obtain a desired set of metal protrusions.

A perforating element **24** can have a shape and/or a dimension, which varies with the depth of the perforating element **24**. The variation can be a result of the etching process and/or the formation of the set of metal protrusions. The set of metal protrusions can be conducive to field emission and/or field-enhanced thermionic emission. Furthermore, a characteristic lateral size of the metal protrusions can be at least one half the Bohr radius in the semiconductor layer **12** and/or the two-dimensional carrier gas **16** (if present). In an embodiment, the characteristic lateral size also is less than the characteristic length scale.

While aspects of the invention are shown and described in conjunction with a device having a two-dimensional carrier gas **16**, it is understood that aspects of the invention can be applied to devices without a two-dimensional carrier gas **16**. In this case, the perforating ohmic contact **20** also can reduce overall contact resistance due to an increased perimeter of the ohmic electrode and an increased current around the sharp edges of the electrode protrusions. Furthermore, embodiments of the invention can be utilized in semiconductor devices containing multiple two-dimensional carrier gas regions.

In any event, as described herein, a characteristic length scale can be selected based on a sheet resistance of the semiconductor layer **14** and a contact resistance per unit length of a metal to be used for the perforating ohmic contact **20**. FIGS. **3A** and **3B** show side and perspective views, respectively, of an illustrative perforating element **24** in a semiconductor structure **11** according to an embodiment. As illustrated, the perforating element **24** extends through the semiconductor layer **14** and the two-dimensional carrier gas **16**, and partially extends into the semiconductor layer **12**. As a result, the perforating element **24** has a contact area **40** with the two-dimensional carrier gas **16**. A specific resistance between the metal of the perforating element **24** and the two-dimensional carrier gas **16**, R_m , can be measured in units of Ohm×meters. A resistance of the two-dimensional carrier gas **16** per square, R_{sh} , and can be measured in Ohms. The conductivity of the two-dimensional carrier gas **16** can account for a large portion of conductivity of semiconductor layer **12**. The placement/spacing of the perforating elements **24** in the semiconductor structure **11** can comprise an optimization parameter, which can be selected to decrease a resistance of the corresponding perforating ohmic contact.

FIG. **4** shows an illustrative geometrical model for calculating a resistance of a perforating ohmic contact according to an embodiment. The model includes an electrode **42** comprising multiple blade like recessed electrode segments **44A-44D** connected by a metal layer **46**. The electrode segments **44A-44D** can have the same potential applied thereto, a ground can be applied to an electrode **48**, and the electrodes **44A-44D** can be separated by a channel region **49**.

Over a distance W , there are $W/(d+x)$ electrodes **44A-44D**, where d is a thickness of an electrode **44A-44D**, and x is a distance between two adjacent electrodes **44A-44D**. A perimeter of each electrode **44A-44D** is given by $P=2(L+d)$ with L being a length of an electrode **44A-44D**. An area of an individual electrode **44A-44D** is given by $A=L \cdot d$. A total perimeter of all electrodes **44A-44D** is $P_T=2(L+d) \cdot W/(d+x)$. A total resistance of the system of electrodes **44A-44D** is given by $R_C=R_m/P_T+R_{sh} \cdot L/(x \cdot W/(d+x))$. The expression of R_C can be simplified to yield:

$$R_C = \frac{R_m(d+x)}{2W(L+d)} + R_{sh} \left(\frac{L}{W} \right) \left(1 + \frac{d}{x} \right)$$

The resistance R_C has minima at a value of x given by $x = \sqrt{CR_{sh}AP/R_m}$, where C is a constant that depends on a shape of the electrode **44A-44D** and is on the order of unity. This value can be used to select a characteristic length scale for spacing the cavities, and therefore the corresponding perforating elements, as described herein. For example, for an electrode having a length L of 10 μm and a width d of 1 μm , and for a $R_{sh}=260\Omega$, and a $R_m=1 \Omega \cdot \text{mm}$, $x \sim 8 \mu\text{m}$ using the formula above. Although the derivation has been shown and described with respect to rectangular protrusions, the same result is qualitatively applicable for a great variety of shapes for the perforating elements as indicated in the inset of FIG. **4**. While a single column of electrodes **44A-44D** (or contact pads) is illustrated in FIG. **4**, it is understood that several columns of electrodes can be employed forming an array of electrodes.

In an embodiment, the perforating ohmic contact is an essentially linear contact. To this extent, an embodiment provides a solution for selecting one or more attributes of the perforating ohmic contact to provide the essentially linear behavior. FIG. **5** shows an illustrative equivalent electrical circuit diagram of the geometrical model of FIG. **4** according to an embodiment. As shown in FIG. **5**, a direct resistance, R_{direct} , corresponds to a resistance between the front face **45A** of the perforating ohmic contact (e.g., including each electrode **44A-44D**) and the two-dimensional carrier gas. The resistance R_{direct} can be written as a specific resistance, R_m , which can correspond to a resistance per unit length of the contact at the contact-to-two dimensional gas interface (e.g., measured in Ohm×m) divided by the total length of the frontal contact edge: $d \times N$, where N is the number of electrodes **44A-44D**, and d is the frontal length of a single electrode **44A-44D**. Thus $R_{direct}=R_m/(d \times N)$, with $N=W/(d+x)$, where x is a distance between two adjacent electrodes **44A-44D** and W being the width of the structure as shown in the FIG. **5**. While the above formula assumes that the various electrodes **44A-44D** have frontal contact edges of the same length, d , and are separated by the same distance x , it is understood that the formulas can be readily modified to account for electrodes **44A-44D** having varying lengths, d , and/or separation distances x .

A side resistance, R_{sides} , for the contact corresponds to a total resistance for current to exit the sides **45B** of each electrode **44A-44D** forming the perforating ohmic contact. The side resistance can be calculated by: $R_{sides} \sim R_m/(2LN) + (R_{sh}L)/(f \times N)$, where the first term, $R_m/(2LN)$, similar to direct resistance, is a resistance at the side **45B** of the contact (e.g., each side of each electrode **44A-44D**) at the contact-to-two dimensional gas interface, and $(R_{sh}L)/(f \times N)$ is the resistance due to a resistance of the two dimensional gas in the space between the electrodes **44A-44D**, where R_{sh} is the sheet resistance of the two dimensional gas and L being a length of an electrode **44A-44D**. The current around a contact pad has a finite spreading, as indicated schematically by the spreading domains **47A** and **47B**. Therefore, a factor f is introduced with values in the range of $0 < f < 1$ to account for finite spreading. For example, if only small spreading is observed, the factor f is close to zero. However, for large spreading, the factor f can be close to 1. While the above formula assumes that the various electrodes **44A-44D** have the same length, L , and are separated by the same distance x , it is understood that the formula can be readily modified to account for electrodes **44A-44D** having varying lengths, L , and/or separation distances x .

The entire resistance of the set of electrodes **44A-44D** forming the contact, R_c , can be written as: $R_c(x; d, f, L, R_m, R_{sh}) = 1/(1/R_{direct} + 1/R_{sides})$, where the explicit dependence on the electrode width d , electrode separation x , electrode length L , as well as physical factors such as R_m —specific resistance at the contact and two dimensional gas interface, and R_{sh} —the sheet resistance of two dimensional gas, are indicated. The expression for R_c can be further simplified by introducing non-dimensionalization as:

$x = x^*d$, $W = W^*d$, $L = L^*d$, $R_m = R_m^*d$, $R_{sh} = R_{sh}^*R_m^*$. Here, x^* , W^* , L^* are unitless, R_m^* has units of Ohm, and R_{sh}^* is also unitless. Substituting non-dimensional quantities into the formula above results in:

$$R_c = R_m^* \left[\frac{1 + x^*}{W^*} \right] \left[\frac{1}{1 + \frac{2fL^*x^*}{fx^* + 2R_{sh}^*L^{*2}}} \right]$$

The expression above has a minima for a set of values of x^* , f , L^* , and R_{sh}^* . For example, FIGS. **6A-6C** illustrate the dependence of normalized contact resistance, $R_c W/R_m$, on the length of the contact as a function of various parameters. FIG. **6A** shows the dependence of the normalized contact resistance on the length of the contact for several values of the parameter f , with $x^*=5$, $R_{sh}^*=1$. As expected, the normalized contact resistance increases with a decreased value of f . Similar behavior is observed in FIG. **6B**, where dependence of normalized contact resistance on the length of the contact for several values of the parameter R_{sh}^* is shown for $x^*=5$, $f=0.8$. FIG. **6C** shows that the optimal contact length L^* should be smaller than the contact separation distance x^* for the minima in normalized contact resistance to be present.

The perforating elements **24** (FIG. **1A**) of a perforating ohmic contact **20** (FIG. **1A**) can be arranged in any of various types of patterns. For example, FIGS. **7A-7C** show illustrative arrangements **50A-50C** of perforating elements according to embodiments. In FIG. **7A**, the arrangement **50A** includes perforating elements formed in a blade arrangement, in which each perforating element is an elongate member located in parallel with the other perforating elements. In FIG. **7B**, the arrangement **50B** includes cylindrical

perforating elements formed in a rectangular array. In FIG. **7C**, the arrangement **50C** includes perforating elements of different, irregular shapes and having an irregular distribution. It is understood that these arrangements **50A-50C** are only illustrative of various types of arrangements that can be utilized in embodiments of the perforating ohmic contact.

FIGS. **8A-8C** show illustrative modeling of current flow and distribution of potential for an array of electrodes according to an embodiment. As illustrated, nine cylindrical electrodes **52** are placed in a three by three array arrangement and penetrate a two-dimensional electron gas. To simplify the model, all other layers are assumed to be non-conducting. In each case, each cylindrical electrode **52** has the same potential voltage and a ground is applied to the electrode **54**. FIG. **8A** shows the resulting current flow. As illustrated, current crowding occurs near the first row of electrodes in the region **56**. FIG. **8B** shows a distribution of potential, and FIG. **8C** shows a current distribution for a less conductive two-dimensional electron gas.

Current crowding is a function of a conduction of the region containing the two-dimensional electron gas. As shown in FIG. **8C**, current crowding significantly increases with a decreasing conductivity of the two-dimensional electron gas region. To this extent, in FIG. **8C**, electrodes placed in the second and third row contribute little to the overall contact as most of the current flows from the first row of electrodes. Additionally, the potential has little variation between the first and second rows and virtually no variation between the second and third rows of electrodes. Furthermore, as illustrated in FIG. **8B**, while there is a change in potential ΔV_1 , being the potential drop over an electrode between the applied voltage and the two-dimensional electron gas, this change in potential is smaller than a change in potential ΔV_2 , being the potential drop between the applied voltage and the neighboring two-dimensional electron gas region. The resultant current has a tendency to flow around the electrodes, as can be seen in FIGS. **8A** and **8B**. From the above simulations, it can be seen that the electrode design can be based on the conductive properties of the materials, for example, on the conductive properties of two-dimensional electron gas. For instance, for low conductive two-dimensional electron gas only the first and perhaps second row of electrodes may be important.

As described herein, an embodiment of a perforating ohmic contact can be utilized as an n-type or a p-type contact in various types of devices. For example, FIGS. **9A-9C** show illustrative light emitting diodes **60A-60C** according to embodiments. In FIG. **9A**, the light emitting diode **60A** includes both a p-type contact **62A** and an n-type contact **64A**, which are embodiments of a perforating ohmic contact described herein. In FIG. **9B**, the light emitting diode **60B** includes a p-type perforating ohmic contact **62A**, while the n-type contact **64B** can comprise a regular annealed contact. In FIG. **9C**, the light emitting diode **60C** includes an n-type perforating ohmic contact **64A**, while the p-type contact **62B** can comprise a regular annealed contact.

Similarly, FIGS. **10A-10C** show illustrative transistors **70A-70C** according to embodiments. In FIG. **10A**, the transistor **70A** includes both a source **72A** and a drain **74A**, which are embodiments of a perforating ohmic contact described herein. In FIG. **10B**, the transistor **70B** includes a perforating ohmic source contact **72A**, while the drain **74B** can comprise a regular annealed contact. In FIG. **10C**, the transistor **70C** includes a perforating ohmic drain contact **74A**, while the source **72B** can comprise a regular annealed contact.

11

It is understood that the configurations of the perforating ohmic contacts shown in FIGS. 9A-9C and 10A-10C are only illustrative. For example, a single contact can include a portion including perforating elements and a second portion comprising a regular annealed metallic electrode. In addition, one or more regions of a regular annealed electrode can be recessed into the underlying semiconductor layer(s) thereby forming a large area perforating element. Furthermore, it is understood that a light emitting device and a transistor are only illustrative of various types of devices that can include a perforating ohmic contact. For example, illustrative devices include, but are not limited to, a laser diode, a photodiode, a photomultiplier, a PIN diode, a Schottky diode, and/or the like.

As discussed herein, a perforating ohmic contact may or may not penetrate a two-dimensional carrier gas. To this extent, FIGS. 11A and 11B show side views of an illustrative light emitting device 80 and an illustrative transistor 82 according to embodiments. As illustrated, the light emitting device 80 can include perforating ohmic contacts 84 that penetrate one or more of the underlying semiconductor layers. However, there is no two-dimensional carrier gas below the perforating ohmic contacts 84. The transistor 82 includes a perforating ohmic contact 86 that penetrates one or more of the underlying semiconductor layers as well as a two-dimensional carrier gas 88 located there below.

Illustrative perforating ohmic contacts described herein and regular ohmic contacts were fabricated and the corresponding resistivities were evaluated. FIGS. 12A-12E illustrate the evaluation of the corresponding resistivities. As shown in FIG. 12A, a semiconductor device includes two main resistances, the contact resistance, R_C , and the semiconductor resistance, R_{SH} . The contact resistance can be measured in $\Omega\cdot\text{mm}$, while the semiconductor resistance can be given per square in units of Ω/sq . FIGS. 12B and 12C show TLM measurements for the regular ohmic contacts, while FIGS. 12D and 12E show TLM measurements for the perforating ohmic contacts. As can be determined from these measurements, an overall contact resistance is significantly decreased for the perforating ohmic contacts as compared to the regular ohmic contacts, e.g., from 1 $\Omega\cdot\text{mm}$ to 0.21 $\Omega\cdot\text{mm}$. Additionally, the semiconductor resistance slightly decreased for the perforating ohmic contacts as compared to the regular ohmic contacts, e.g., from 256 Ω/sq to 246 Ω/sq .

In an embodiment, the invention provides a method of designing and/or fabricating a circuit that includes one or more of the devices designed and fabricated as described herein. To this extent, FIG. 13 shows an illustrative flow diagram for fabricating a circuit 126 according to an embodiment. Initially, a user can utilize a device design system 110 to generate a device design 112 for a semiconductor device as described herein. The device design 112 can comprise program code, which can be used by a device fabrication system 114 to generate a set of physical devices 116 according to the features defined by the device design 112. Similarly, the device design 112 can be provided to a circuit design system 120 (e.g., as an available component for use in circuits), which a user can utilize to generate a circuit design 122 (e.g., by connecting one or more inputs and outputs to various devices included in a circuit). The circuit design 122 can comprise program code that includes a device designed as described herein. In any event, the circuit design 122 and/or one or more physical devices 116 can be provided to a circuit fabrication system 124, which can generate a physical circuit 126 according to the circuit design 122. The physical circuit 126 can include one or more devices 116 designed as described herein.

12

In another embodiment, the invention provides a device design system 110 for designing and/or a device fabrication system 114 for fabricating a semiconductor device 116 as described herein. In this case, the system 110, 114 can comprise a general purpose computing device, which is programmed to implement a method of designing and/or fabricating the semiconductor device 116 as described herein. Similarly, an embodiment of the invention provides a circuit design system 120 for designing and/or a circuit fabrication system 124 for fabricating a circuit 126 that includes at least one device 116 designed and/or fabricated as described herein. In this case, the system 120, 124 can comprise a general purpose computing device, which is programmed to implement a method of designing and/or fabricating the circuit 126 including at least one semiconductor device 116 as described herein.

In still another embodiment, the invention provides a computer program fixed in at least one computer-readable medium, which when executed, enables a computer system to implement a method of designing and/or fabricating a semiconductor device as described herein. For example, the computer program can enable the device design system 110 to generate the device design 112 as described herein. To this extent, the computer-readable medium includes program code, which implements some or all of a process described herein when executed by the computer system. It is understood that the term "computer-readable medium" comprises one or more of any type of tangible medium of expression, now known or later developed, from which a stored copy of the program code can be perceived, reproduced, or otherwise communicated by a computing device.

In another embodiment, the invention provides a method of providing a copy of program code, which implements some or all of a process described herein when executed by a computer system. In this case, a computer system can process a copy of the program code to generate and transmit, for reception at a second, distinct location, a set of data signals that has one or more of its characteristics set and/or changed in such a manner as to encode a copy of the program code in the set of data signals. Similarly, an embodiment of the invention provides a method of acquiring a copy of program code that implements some or all of a process described herein, which includes a computer system receiving the set of data signals described herein, and translating the set of data signals into a copy of the computer program fixed in at least one computer-readable medium. In either case, the set of data signals can be transmitted/received using any type of communications link.

In still another embodiment, the invention provides a method of generating a device design system 110 for designing and/or a device fabrication system 114 for fabricating a semiconductor device as described herein. In this case, a computer system can be obtained (e.g., created, maintained, made available, etc.) and one or more components for performing a process described herein can be obtained (e.g., created, purchased, used, modified, etc.) and deployed to the computer system. To this extent, the deployment can comprise one or more of: (1) installing program code on a computing device; (2) adding one or more computing and/or I/O devices to the computer system; (3) incorporating and/or modifying the computer system to enable it to perform a process described herein; and/or the like.

The foregoing description of various aspects of the invention has been presented for purposes of illustration and description. It is not intended to be exhaustive or to limit the invention to the precise form disclosed, and obviously, many modifications and variations are possible. Such modifica-

13

tions and variations that may be apparent to an individual in the art are included within the scope of the invention as defined by the accompanying claims.

What is claimed is:

1. A light emitting device comprising:
 - a semiconductor structure including:
 - a semiconductor layer, wherein the semiconductor layer is one of: an n-type layer or a p-type layer; and
 - a light emitting region, wherein the semiconductor layer is located on a first side of the light emitting region; and
 - a perforating contact to the semiconductor layer, the perforating contact including:
 - a plurality of perforating elements formed of a metal deposited in a plurality of cavities in the semiconductor layer, wherein the plurality of cavities are separated from each other by a characteristic length scale selected based on a sheet resistance of the semiconductor layer and a contact resistance per unit length of the metal; and
 - a top layer of the metal located over an area of the semiconductor structure including the plurality of cavities.
2. The device of claim 1, wherein at least one of the plurality of perforating elements includes a set of metal protrusions laterally penetrating the semiconductor layer, and wherein a metal protrusion in the set of metal protrusions has one of: a pyramidal, a prismatic, or a conic shape.
3. The device of claim 2, wherein the set of metal protrusions have a characteristic lateral size, wherein the characteristic lateral size is at least one half the Bohr radius in the semiconductor layer, and wherein the characteristic lateral size is less than the characteristic length scale.
4. The device of claim 1, wherein the semiconductor structure comprises a group III nitride based semiconductor structure, and wherein the semiconductor layer is formed of a first group III nitride material, the semiconductor structure further including:
 - a second layer adjacent to a second side of the light emitting region opposite the first side, wherein the second layer is formed of a second group III nitride material and is the other of: the n-type layer or the p-type layer; and
 - a contact to the second layer.
5. The device of claim 1, wherein at least some of the plurality of perforating elements have at least one of: a shape or a dimension that varies based on a depth of the perforating element.
6. The device of claim 1, wherein the characteristic length scale for the plurality of cavities minimizes a total resistance of the perforating ohmic contact calculated based on the sheet resistance of the semiconductor layer, an area of the cavity, a perimeter of the cavity, and the contact resistance per unit length of the metal of the perforating ohmic contact.
7. The device of claim 1, wherein the semiconductor structure further includes at least one layer of low conductive or isolating material, and wherein the plurality of perforating elements extend through the at least one layer of low conductive or isolating material.
8. The device of claim 1, wherein the device is configured to operate as at least one of: a light emitting diode, a light emitting laser diode, or a photodiode.
9. A device comprising:
 - a semiconductor structure including a semiconductor layer; and
 - a perforating contact to the semiconductor layer, the perforating contact including:

14

- a plurality of perforating elements formed of a metal deposited in a plurality of cavities in the semiconductor structure, wherein at least one of the plurality of perforating elements includes a set of metal protrusions extending from the cavity and laterally penetrating the semiconductor layer, wherein the set of metal protrusions have a characteristic lateral size, wherein the characteristic lateral size is at least one half the Bohr radius in at least one of: the semiconductor layer or a two-dimensional carrier gas region in the semiconductor structure, and wherein the characteristic lateral size is less than the characteristic length scale; and
 - a top layer of the metal located over an area of the semiconductor structure including the plurality of cavities.
10. The device of claim 9, wherein a metal protrusion in the set of metal protrusions has one of: a pyramidal, a prismatic, or a conic shape.
 11. The device of claim 9, wherein the plurality of cavities are separated from each other by a characteristic length scale selected based on a sheet resistance of the semiconductor layer and a contact resistance per unit length of the metal.
 12. The device of claim 11, wherein the characteristic length scale for the plurality of cavities minimizes a total resistance of the perforating ohmic contact calculated based on the sheet resistance of the semiconductor layer, an area of the cavity, a perimeter of the cavity, and the contact resistance per unit length of the metal of the perforating contact.
 13. The device of claim 9, wherein the semiconductor layer is one of: an n-type layer or a p-type layer, the device further including an active region configured for at least one of: light generation or light sensing, wherein the semiconductor layer is located on a first side of the active region.
 14. The device of claim 9, wherein the semiconductor structure comprises a group III nitride based semiconductor structure, and wherein the semiconductor layer is formed of a first group III nitride material, the semiconductor structure further including:
 - a second layer adjacent to the semiconductor layer, wherein the second layer is formed of a second group III nitride material; and
 - a two-dimensional carrier gas formed at a junction of the second layer and the semiconductor layer, wherein the at least some of the plurality of perforating elements extend through the second layer and at least partially through the semiconductor layer.
 15. The device of claim 9, wherein at least some of the plurality of perforating elements have at least one of: a shape or a dimension that varies based on a depth of the perforating element.
 16. The device of claim 9, wherein the semiconductor structure further includes at least one layer of low conductive or isolating material, and wherein the plurality of perforating elements extend through the at least one layer of low conductive or isolating material.
 17. The device of claim 9, wherein the device is configured to operate as at least one of: a light emitting diode, a light emitting laser diode, a transistor, a photodiode, a Schottky diode, or a PIN diode.
 18. A device comprising:
 - a semiconductor structure including:
 - an n-type semiconductor layer;
 - a p-type semiconductor layer; and
 - an active region located between the n-type semiconductor layer and the p-type semiconductor layer,

wherein the active region is configured for at least one of: light emission or light sensing; and
 a perforating contact to one of: the n-type semiconductor layer or the p-type semiconductor layer, the perforating contact including:
 a plurality of perforating elements formed of a metal deposited in a plurality of cavities in the one of: the n-type semiconductor layer or the p-type semiconductor layer, wherein the semiconductor structure is annealed such that at least one of the plurality of perforating elements includes a set of metal protrusions extending from the cavity and laterally penetrating the one of: the n-type semiconductor layer or the p-type semiconductor layer; and
 a top layer of the metal located over an area of the semiconductor structure including the plurality of cavities.

19. The device of claim **18**, wherein the plurality of cavities are separated from each other by a characteristic length scale that minimizes a total resistance of the perforating ohmic contact calculated based on a sheet resistance of the one of: the n-type semiconductor layer or the p-type semiconductor layer and a contact resistance per unit length of the metal.

20. The device of claim **19**, wherein the set of metal protrusions have a characteristic lateral size that is at least one half the Bohr radius in the one of: the n-type semiconductor layer or the p-type semiconductor layer, and wherein the characteristic lateral size is less than the characteristic length scale.

* * * * *