



US010180030B2

(12) **United States Patent**
Russell

(10) **Patent No.: US 10,180,030 B2**
(45) **Date of Patent: Jan. 15, 2019**

(54) **RAM ACCELERATOR SYSTEM**

(56) **References Cited**

(71) Applicant: **HYPERSCIENCES, INC.**, Spokane, WA (US)

U.S. PATENT DOCUMENTS

(72) Inventor: **Mark C. Russell**, Spokane, WA (US)

2,544,573 A	3/1951	Vincent
2,621,732 A	12/1952	Ahlgren
2,913,959 A	11/1959	Mohaupt
3,075,463 A	1/1963	Eilers et al.
3,185,224 A	5/1965	Robinson, Jr.
3,244,232 A	4/1966	Myers
3,253,511 A	5/1966	Zwicky
3,441,095 A	4/1969	Youmans
3,695,715 A	10/1972	Godfrey
3,863,723 A	2/1975	Godfrey
3,867,867 A	2/1975	Duff
4,030,557 A	6/1977	Alvis et al.
4,063,486 A	12/1977	Ashley

(73) Assignee: **HYPERSCIENCES, INC.**, Spokane, WA (US)

(*) Notice: Subject to any disclaimer, the term of this patent is extended or adjusted under 35 U.S.C. 154(b) by 0 days.

(21) Appl. No.: **15/292,011**

(Continued)

(22) Filed: **Oct. 12, 2016**

FOREIGN PATENT DOCUMENTS

(65) **Prior Publication Data**

US 2017/0030143 A1 Feb. 2, 2017

DE	2420035	3/1976
WO	1999037878 A1	7/1999

Related U.S. Application Data

(62) Division of application No. 13/841,236, filed on Mar. 15, 2013, now Pat. No. 9,500,419.

(51) **Int. Cl.**

E21B 7/00	(2006.01)
F41A 1/04	(2006.01)
F41A 1/02	(2006.01)
E21C 37/00	(2006.01)

(52) **U.S. Cl.**

CPC **E21B 7/00** (2013.01); **E21B 7/007** (2013.01); **E21C 37/005** (2013.01); **F41A 1/02** (2013.01); **F41A 1/04** (2013.01); **Y10T 83/0524** (2015.04)

(58) **Field of Classification Search**

CPC F41A 1/04; F41F 1/00; E21B 7/00; E21B 43/116

USPC 89/7, 8; 175/2, 4.5, 4.54-4.57

See application file for complete search history.

OTHER PUBLICATIONS

Becamel, Philippe, "Patent Cooperation Treaty International Preliminary Report on Patentability dated Sep. 15, 2015", Patent Cooperation Treaty Application PCT/US2014/012317, dated Sep. 15, 2015.

(Continued)

Primary Examiner — Jonathan C Weber

(74) *Attorney, Agent, or Firm* — Lindauer Law, PLLC

(57) **ABSTRACT**

One or more ram accelerator devices may be used to form one or more holes in geologic or other material. These holes may be used for drilling, tunnel boring, excavation, and so forth. The ram accelerator devices propel projectiles which are accelerated by combustion of one or more combustible gasses in a ram effect to reach velocities exceeding 500 meters per second.

20 Claims, 15 Drawing Sheets

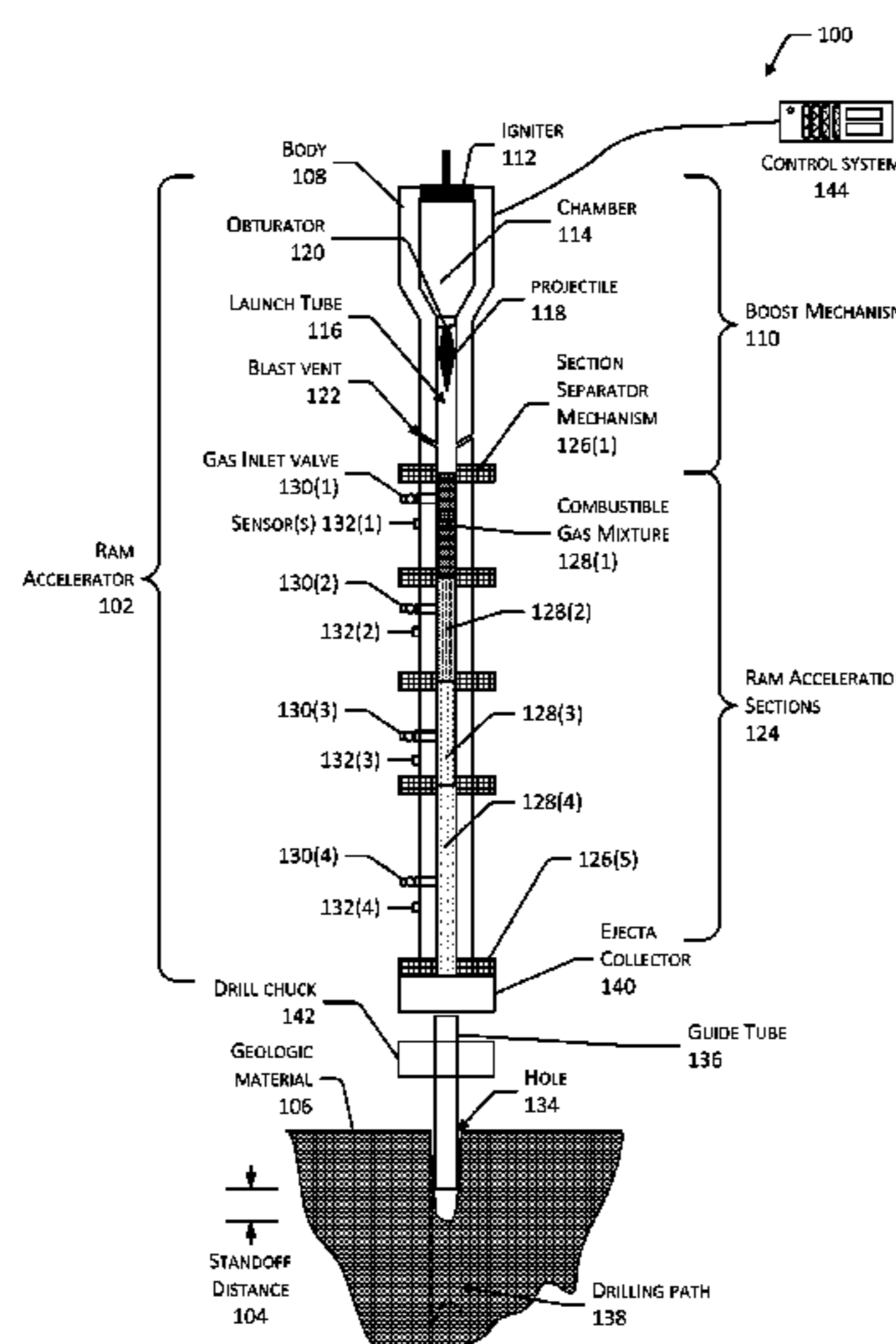

(56)

References Cited

U.S. PATENT DOCUMENTS

4,123,975	A *	11/1978	Mohaupt	F42B 10/08 102/518
4,467,878	A	8/1984	Ibsen	
4,582,147	A	4/1986	Dardick	
4,638,712	A	1/1987	Chawla et al.	
4,679,637	A	7/1987	Cherrington et al.	
4,722,261	A	2/1988	Titus	
4,791,850	A	12/1988	Minovitch	
4,907,488	A	3/1990	Seberger	
4,932,306	A	6/1990	Rom	
4,982,647	A	1/1991	Hertzberg et al.	
5,063,826	A *	11/1991	Bulman	F41A 1/04 102/374
5,097,743	A	3/1992	Hertzberg et al.	
5,098,163	A	3/1992	Young, III	
5,421,237	A	6/1995	Naumann	
5,487,405	A	1/1996	Skoglund	
5,574,244	A	11/1996	Powell et al.	
5,578,783	A	11/1996	Brandeis	
5,768,940	A	6/1998	Kawaguchi et al.	
5,833,003	A	11/1998	Longbottom et al.	
5,996,709	A	12/1999	Norris	
6,000,479	A	12/1999	Ambs	
6,035,784	A	3/2000	Watson	
6,457,417	B1	10/2002	Beal	
6,467,387	B1	10/2002	Espinosa et al.	
6,591,731	B2	7/2003	Goldstein	
7,069,862	B2	7/2006	Bassett	
7,681,352	B2	3/2010	Fu et al.	
7,942,481	B2	5/2011	Leppanen	
8,104,568	B2	1/2012	Luchini et al.	
8,181,561	B2	5/2012	Riggs et al.	
8,302,584	B1	11/2012	Lu	
8,943,970	B2	2/2015	Greeley et al.	
9,169,695	B1	10/2015	Calvert	
9,540,895	B2	1/2017	Mackenzie et al.	
2002/0100361	A1 *	8/2002	Russell	F41A 1/00 89/14.5
2005/0034896	A1	2/2005	Youan	
2007/0044963	A1	3/2007	MacDougall	
2008/0205191	A1	8/2008	Coste et al.	
2010/0032206	A1	2/2010	Becker et al.	
2011/0114388	A1	5/2011	Lee et al.	
2014/0260930	A1	9/2014	Russell	

OTHER PUBLICATIONS

Committee on Advance Drilling, "Drilling and Excavation Technologies for the Future", National Research Council, ISBN: 0-309-57320-3, «Retrieved from <http://www.nap.edu/catalog/2349.html>, 1994, 176.

Copenheaver, Blaine R., "Patent Cooperation Treaty International Search Report and Written Opinion dated Aug. 10, 2015", Patent Cooperation Treaty Application No. PCT/US2015/030320, Patent Cooperation Treaty, dated Aug. 10, 2015.

Gold, et al., "Concrete Penetration by Eroding Projectiles Experiments and Analysis", Journal of Engineering Mechanics, v122, pp. 145-152 «Retrieved from ascelibrary.org on Feb. 17, 2013», Feb. 1996, 145-152.

Gold, et al., "Constitutive Models for Concrete Penetration Analysis", Journal of Engineering Mechanics v122 «Retrieved from ascelibrary.org on Feb. 17, 2013 », Mar. 1996, 230-238.

Lundquist, Robert G., "Underground Tests of the Ream Method of Rock Fragmentation for High-Speed Tunneling", Rapid Excavation and Tunneling Conference Proceedings, Ch 56«Retrieved from <http://www.onemine.prg/view/?d=689528D8459E7257609C73381053FBF203FD5CC5A9FC7839952A414670F0591638551>, Mar. 13, 2013», Jan. 1974, 825-840.

Semick, Joshua T., "Notice of Allowance dated May 25, 2016", U.S. Appl. No. 14/708,932, The United States Patent and Trademark Office, dated May 25, 2016.

Weber, Jonathan C., "Non-Final Office Action dated Jun. 1, 2015", U.S. Appl. No. 13/841/236, The United States Patent and Trademark Office, dated Jun. 1, 2015.

Weber, Jonathan C., "Notice of Allowance dated Jul. 14, 2016", U.S. Appl. No. 13/841,236, The United States Patent and Trademark Office, dated Jul. 14, 2016.

Young, Lee W., "Patent Cooperation Treaty International Search Report and Written Opinion dated Jan. 8, 2016", Patent Cooperation Treaty Application No. PCT/US15/56947, Patent Cooperation Treaty, dated Jan. 8, 2016.

Young, Lee W., "Patent Cooperation Treaty International Search Report and Written Opinion dated May 16, 2014", Patent Cooperation Treaty Application No. PCT/US2014/012317, Patent Cooperation Treaty, dated May 16, 2014.

Kasten, Klaus, "European Search Report dated Jan. 23, 2017", European Application No. 14770528.9, European Patent Office, dated Jan. 23, 2017.

Young, Lee W., "Patent Cooperation Treaty International Search Report and Written Opinion dated Jan. 19, 2017", Patent Cooperation Treaty Application No. PCT/US2016/060129, Patent Cooperation Treaty, dated Jan. 19, 2017.

Bai, Lingfei, "International Preliminary Report on Patentability dated Nov. 2, 2017," Patent Cooperation Treaty Application No. PCT/US2016/028704, Patent Cooperation Treaty, dated Nov. 2, 2017.

Sayre, James G., "Non-Final Office Action dated Aug. 24, 2017", U.S. Appl. No. 14/919,657, The United States Patent and Trademark Office, dated Aug. 24, 2017.

Semick, Joshua T., "Non-final Office Action dated Jul. 18, 2017", U.S. Appl. No. 15/246,414, The United States Patent and Trademark Office, dated Jul. 18, 2017.

Hutchins, Cathleen R., "Non-Final Office Action dated Apr. 12, 2018", U.S. Appl. No. 15/340,753, The United States Patent and Trademark Office, dated Apr. 12, 2018.

Portocarrero, Manuel C., "Non-Final Office Action dated Apr. 11, 2018", U.S. Appl. No. 15/348,796, The United States Patent and Trademark Office, dated Apr. 11, 2018.

Runyan, Ronald R., "Non-Final Office Action dated Apr. 12, 2018", U.S. Appl. No. 15/135,452, The United States Patent and Trademark Office, dated Apr. 12, 2018.

Sayre, James G., "Notice of Allowance dated Feb. 5, 2018", U.S. Appl. No. 14/919,657, The United States Patent and Trademark Office, dated Feb. 5, 2018.

Semick, Joshua T., "Final Office Action dated Feb. 2, 2018", U.S. Appl. No. 15/246,414, The United States Patent and Trademark Office, dated Feb. 5, 2018.

Wittmann-Regis, Agnes, "PCT International Preliminary Report on Patentability dated May 4, 2017", Patent Cooperation Treaty Application No. PCT/US2015/056947, Patent Cooperation Treaty, dated May 4, 2017.

Wittmann-Regis, Agnes, "PCT International Preliminary Report on Patentability dated May 24, 2018", Patent Cooperation Treaty Application No. PCT/US16/60129, Patent Cooperation Treaty, dated May 24, 2018.

* cited by examiner

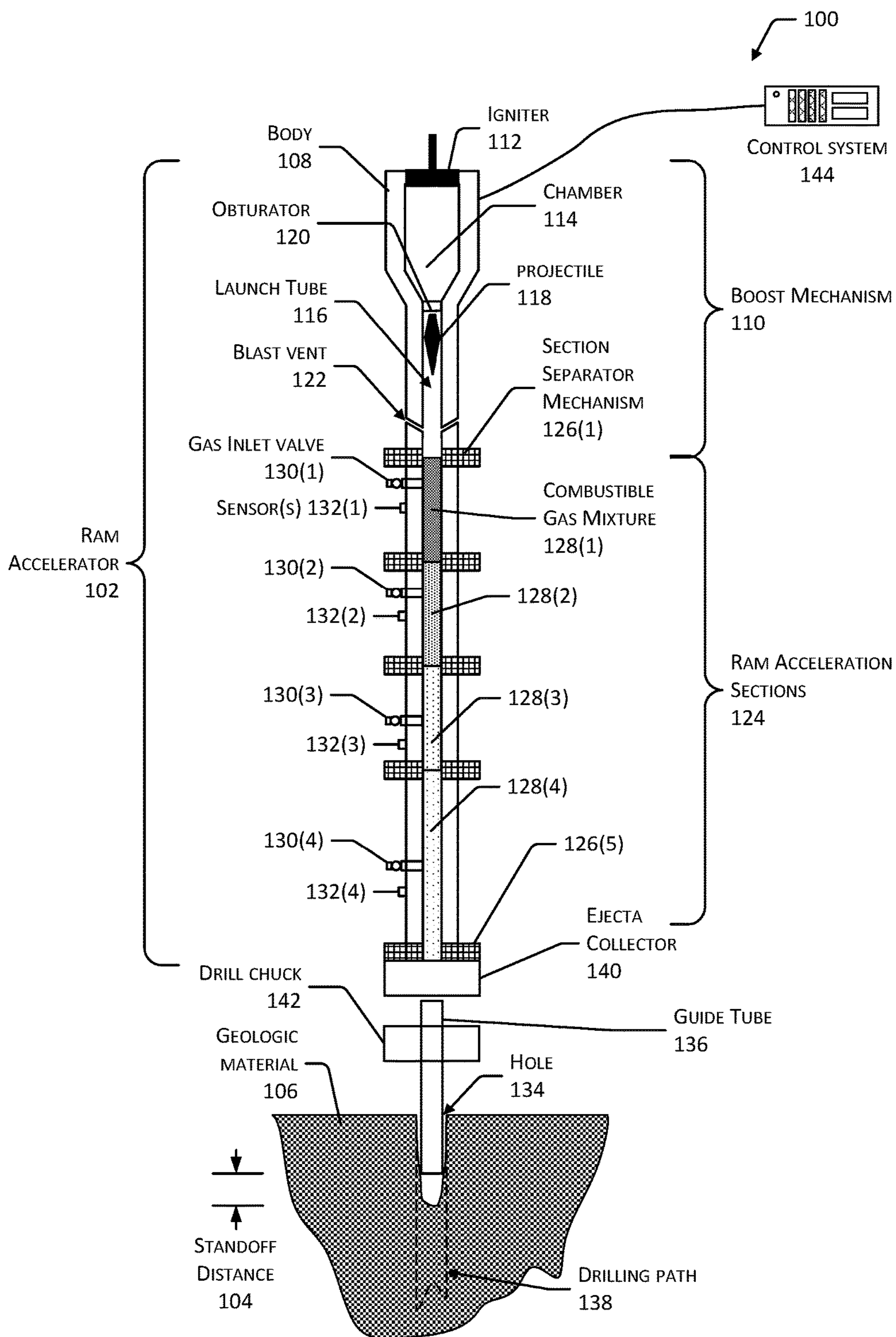

FIG. 1

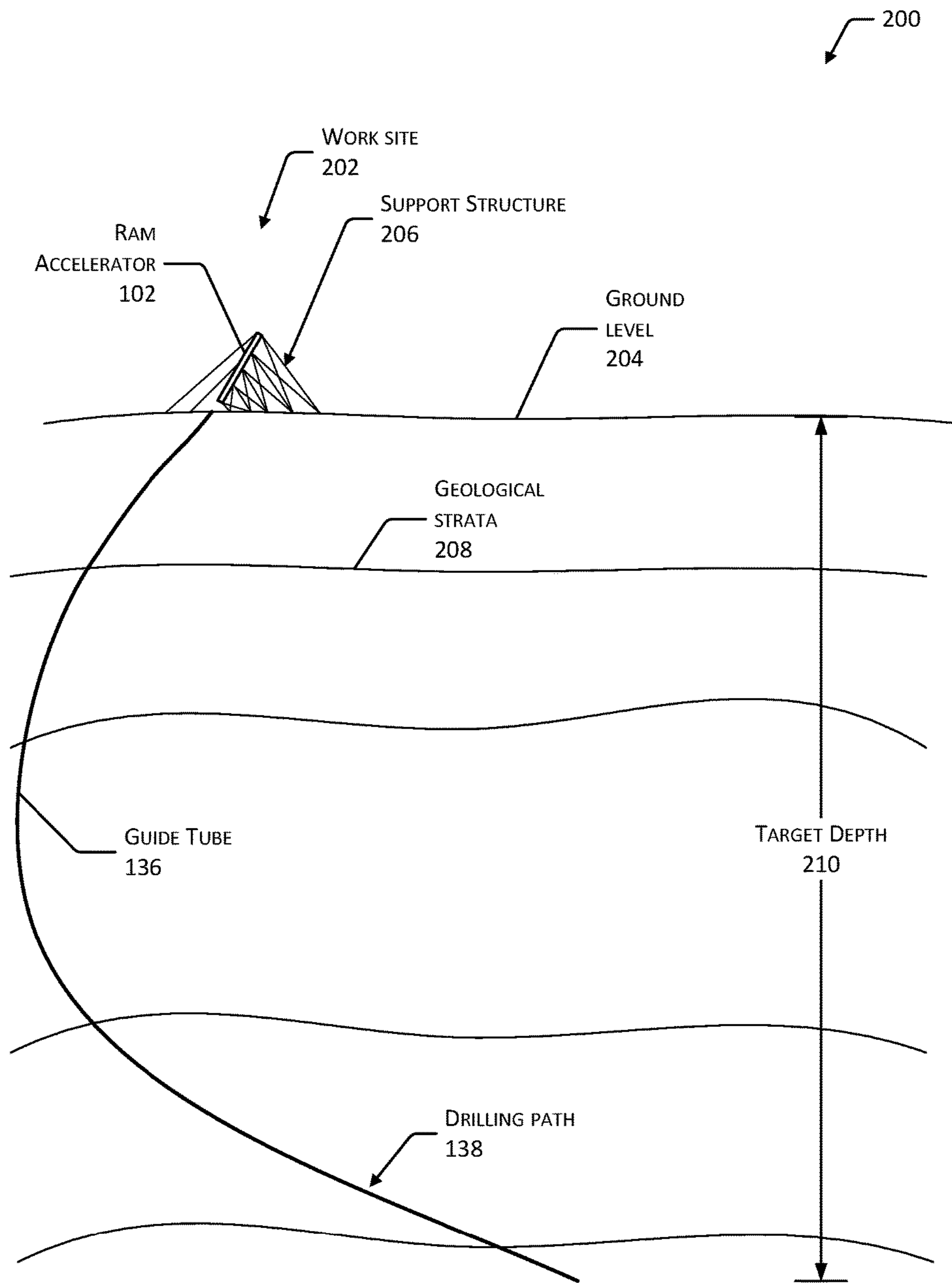

FIG. 2

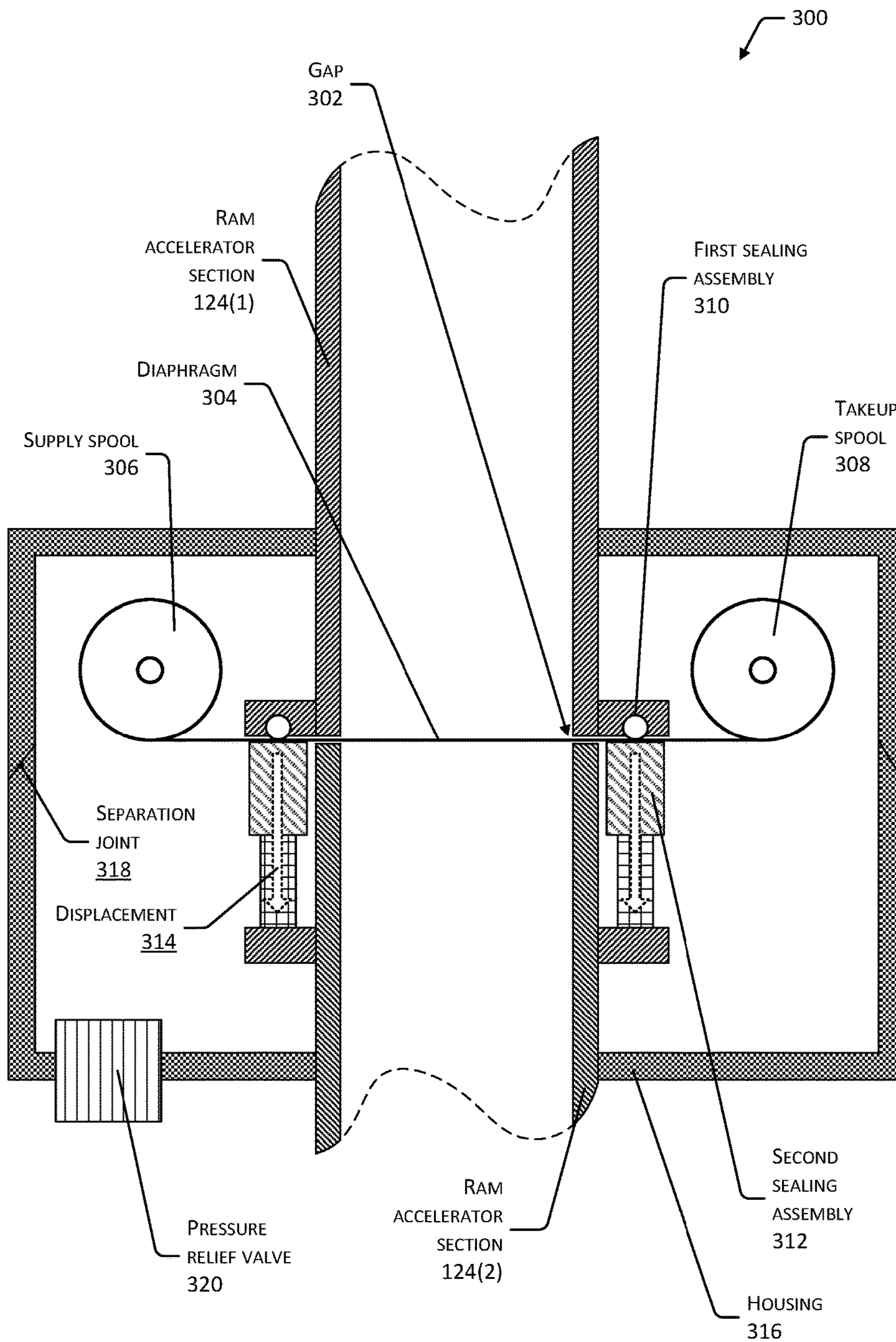

FIG. 3

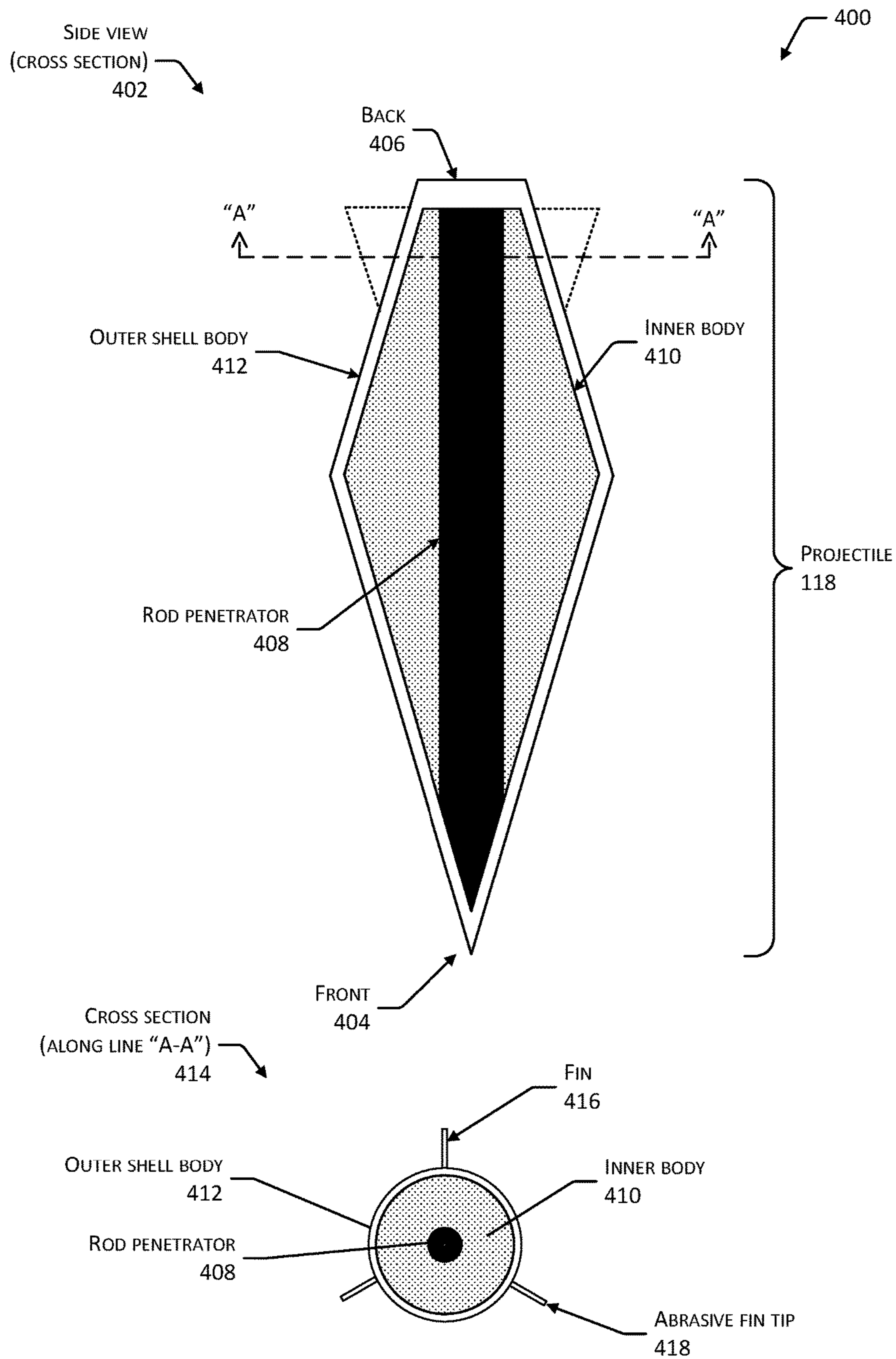

FIG. 4

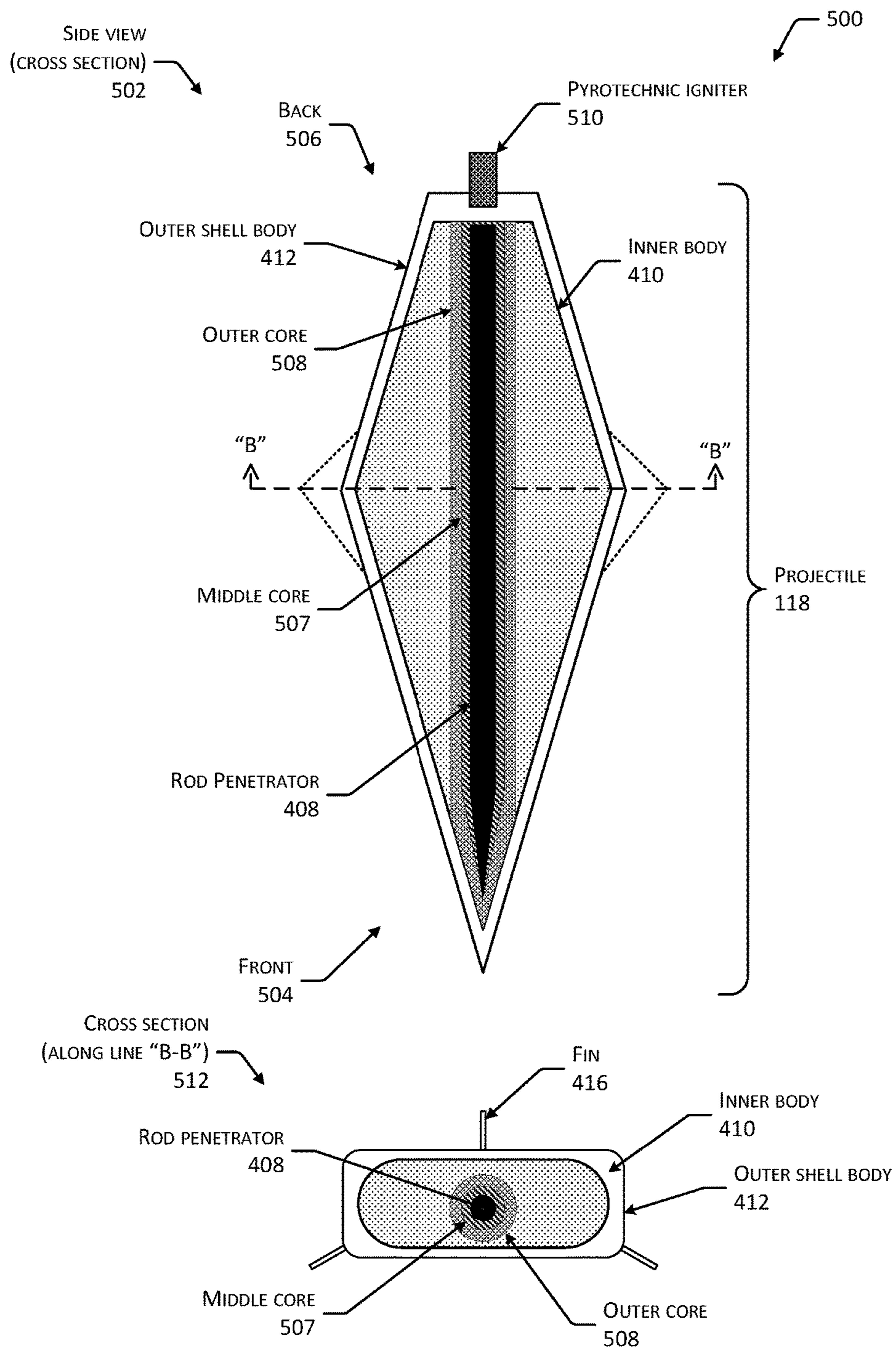

FIG. 5

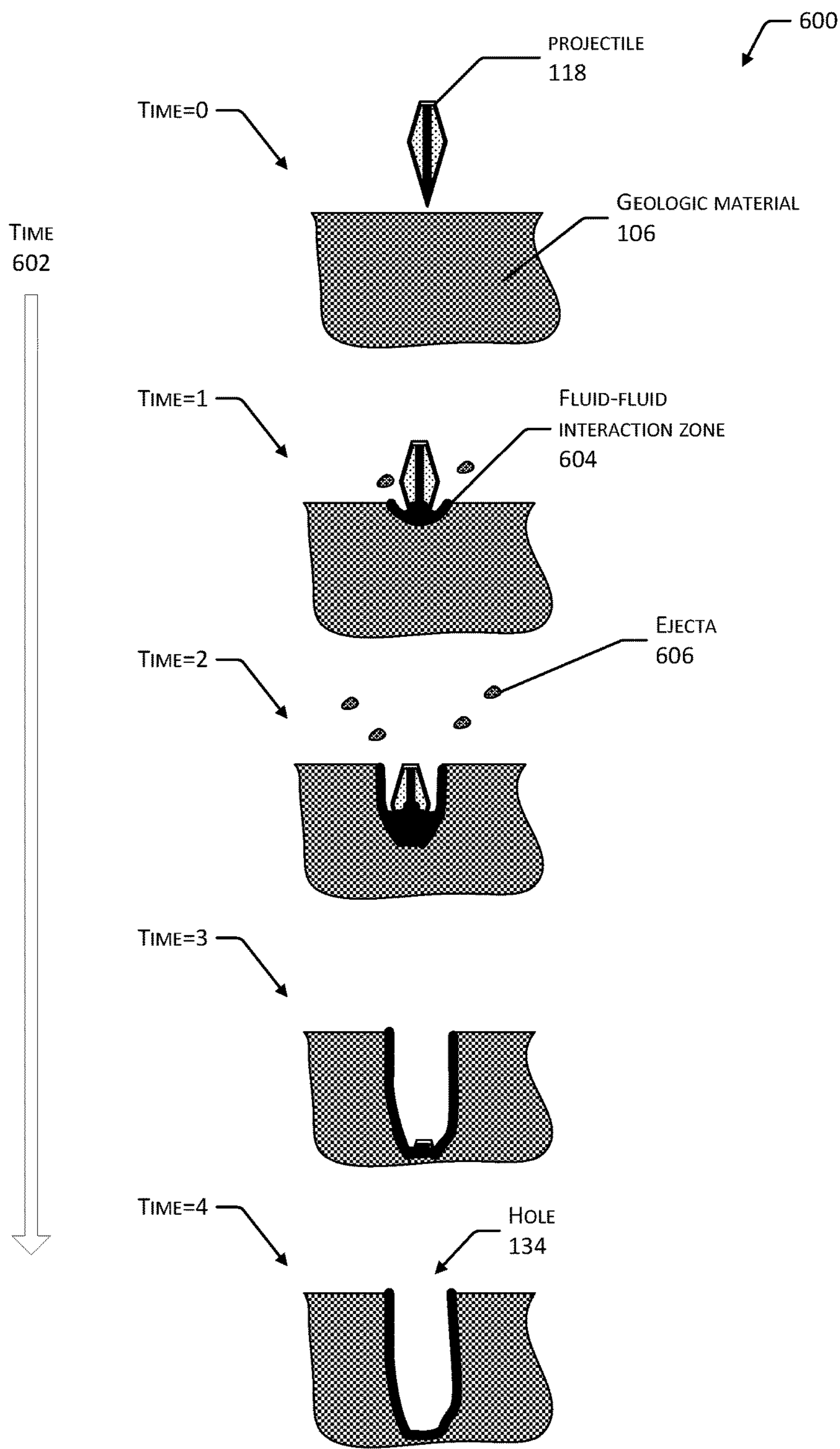

FIG. 6

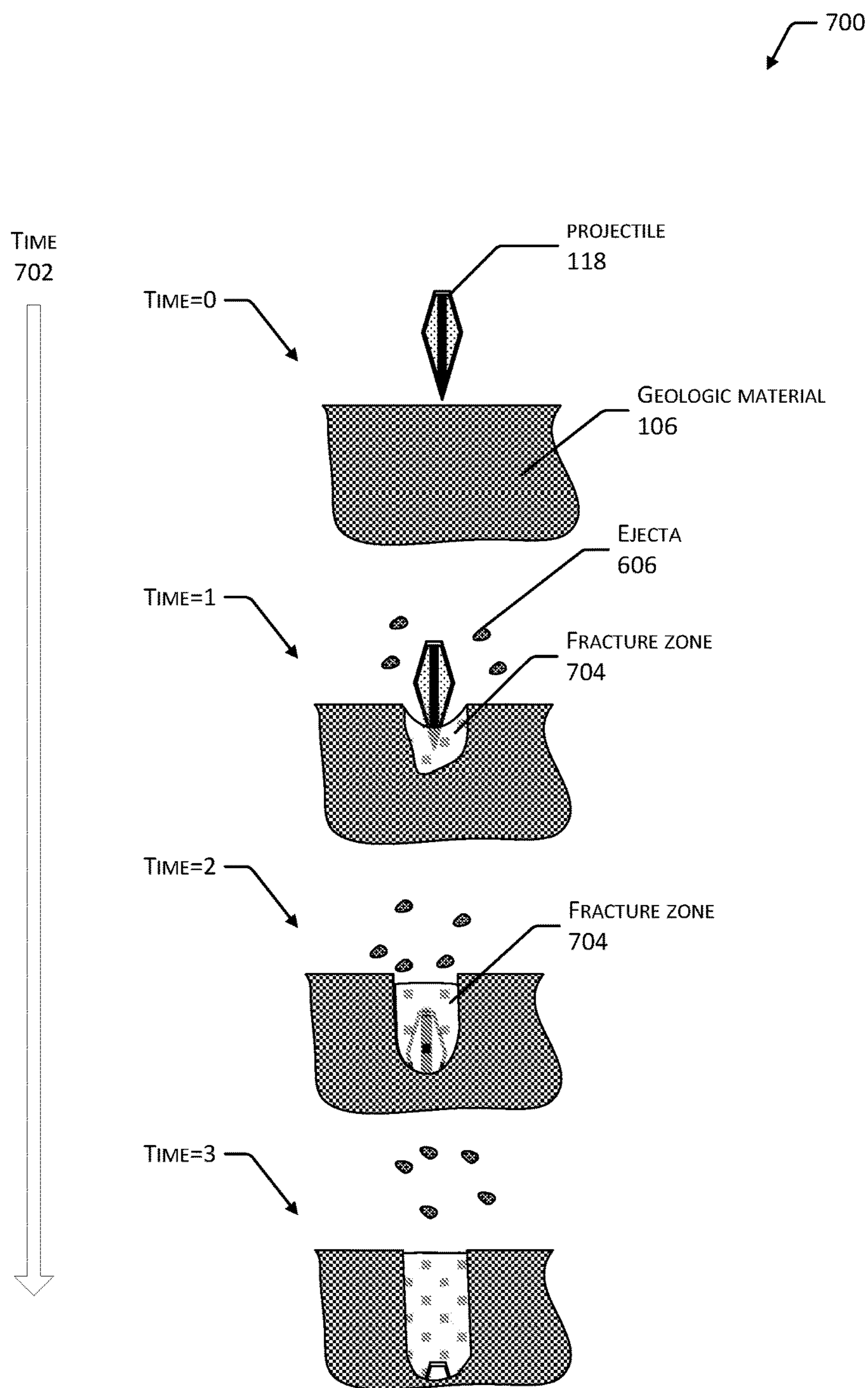

FIG. 7

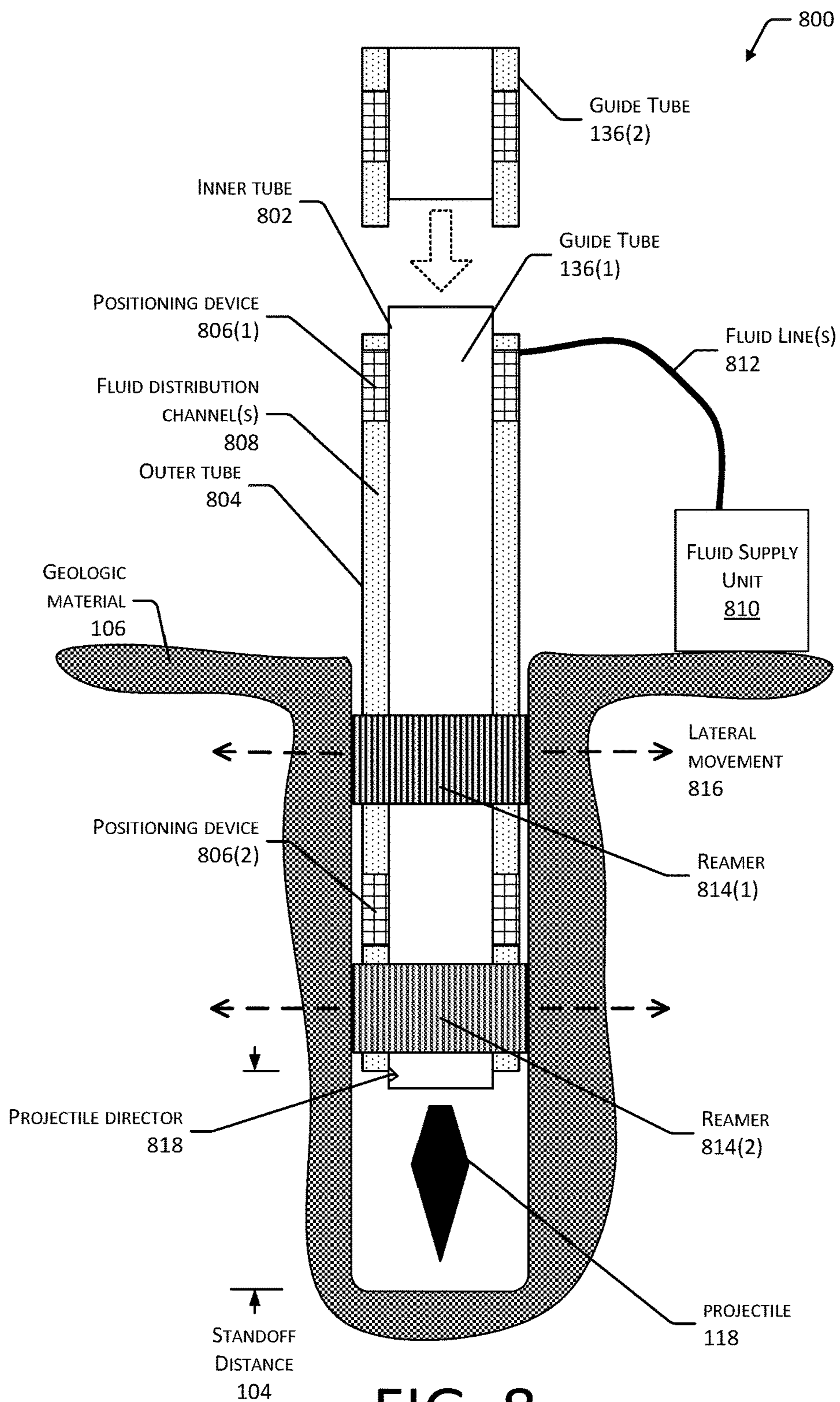

FIG. 8

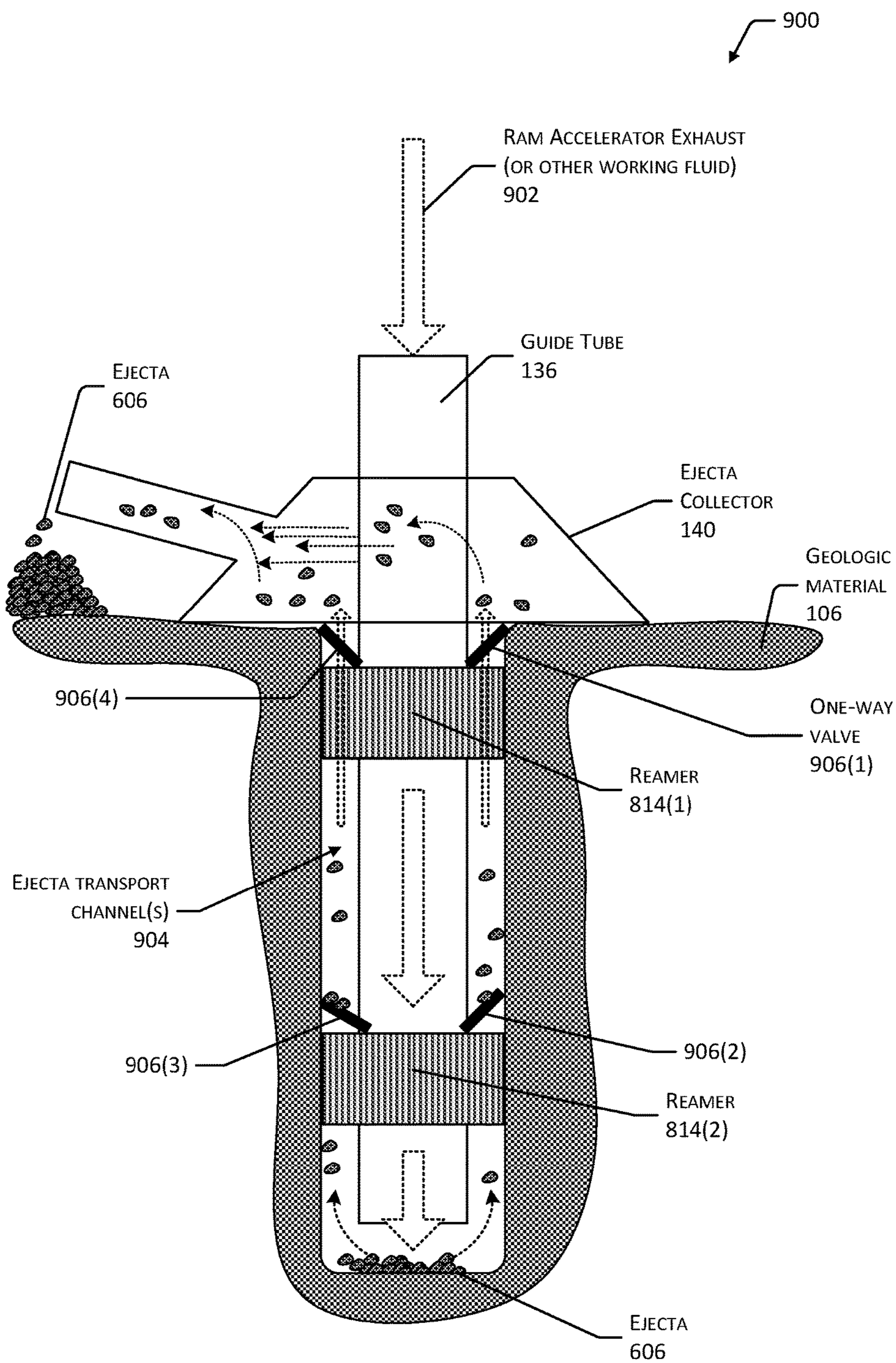

FIG. 9

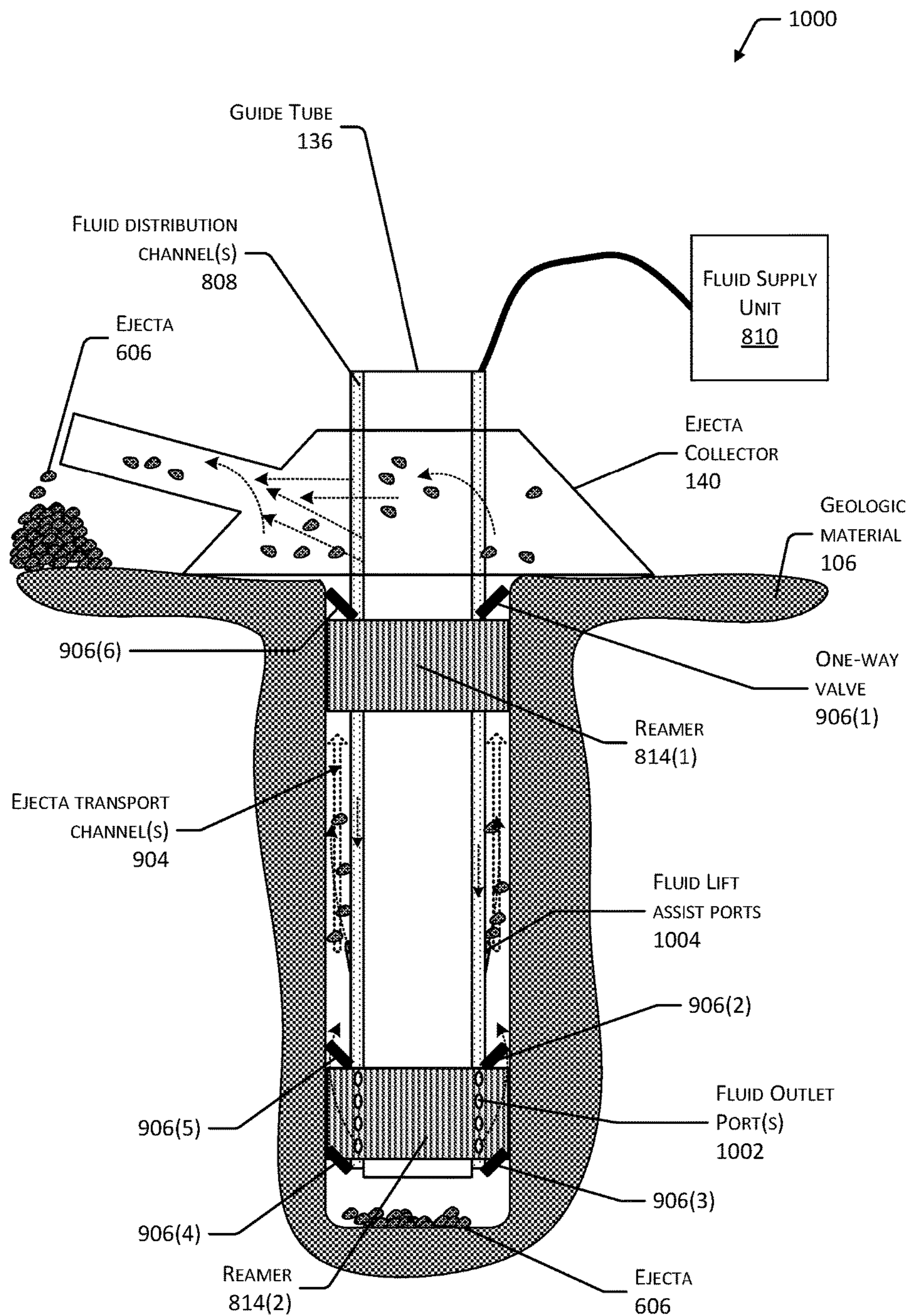

FIG. 10

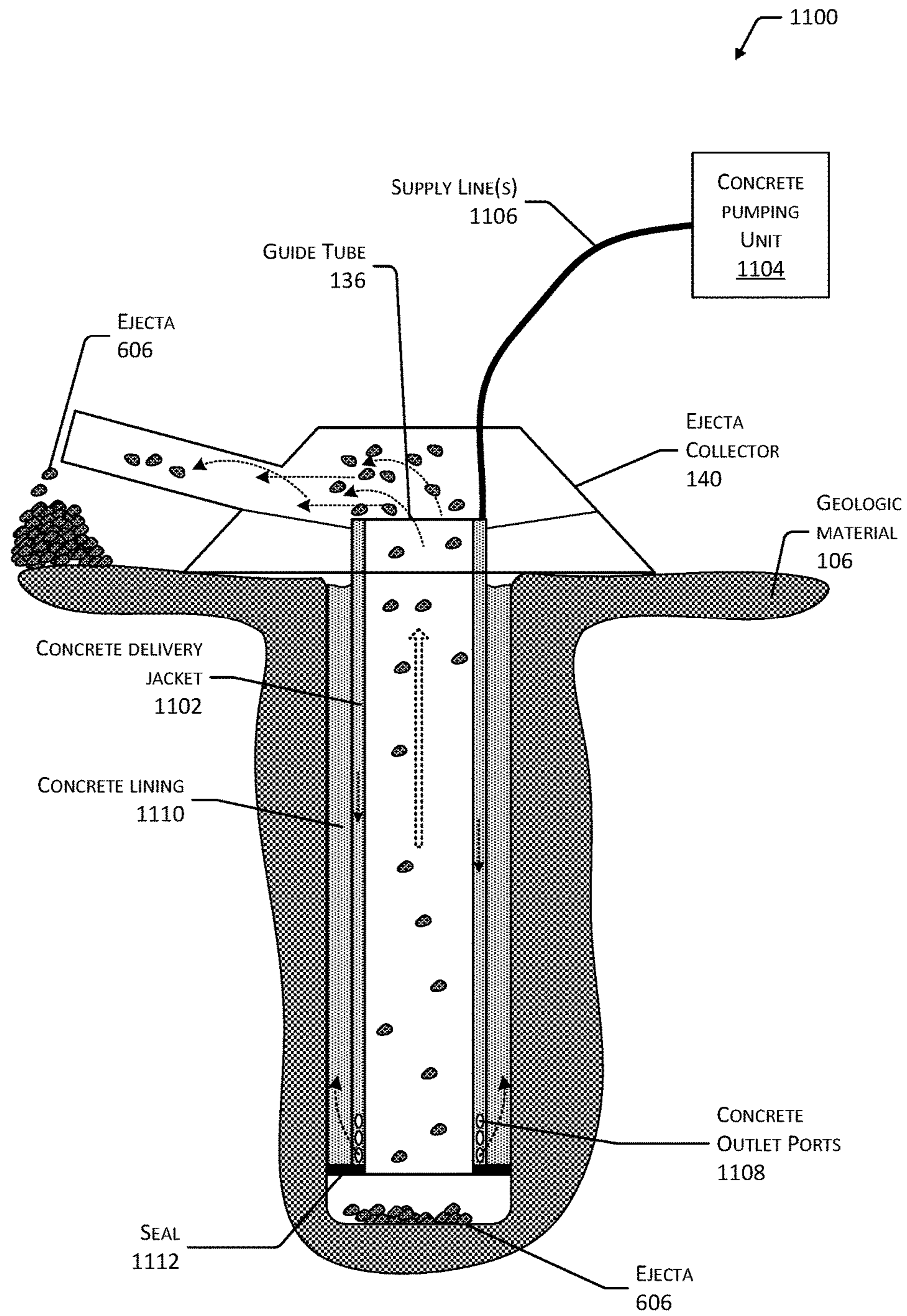

FIG. 11

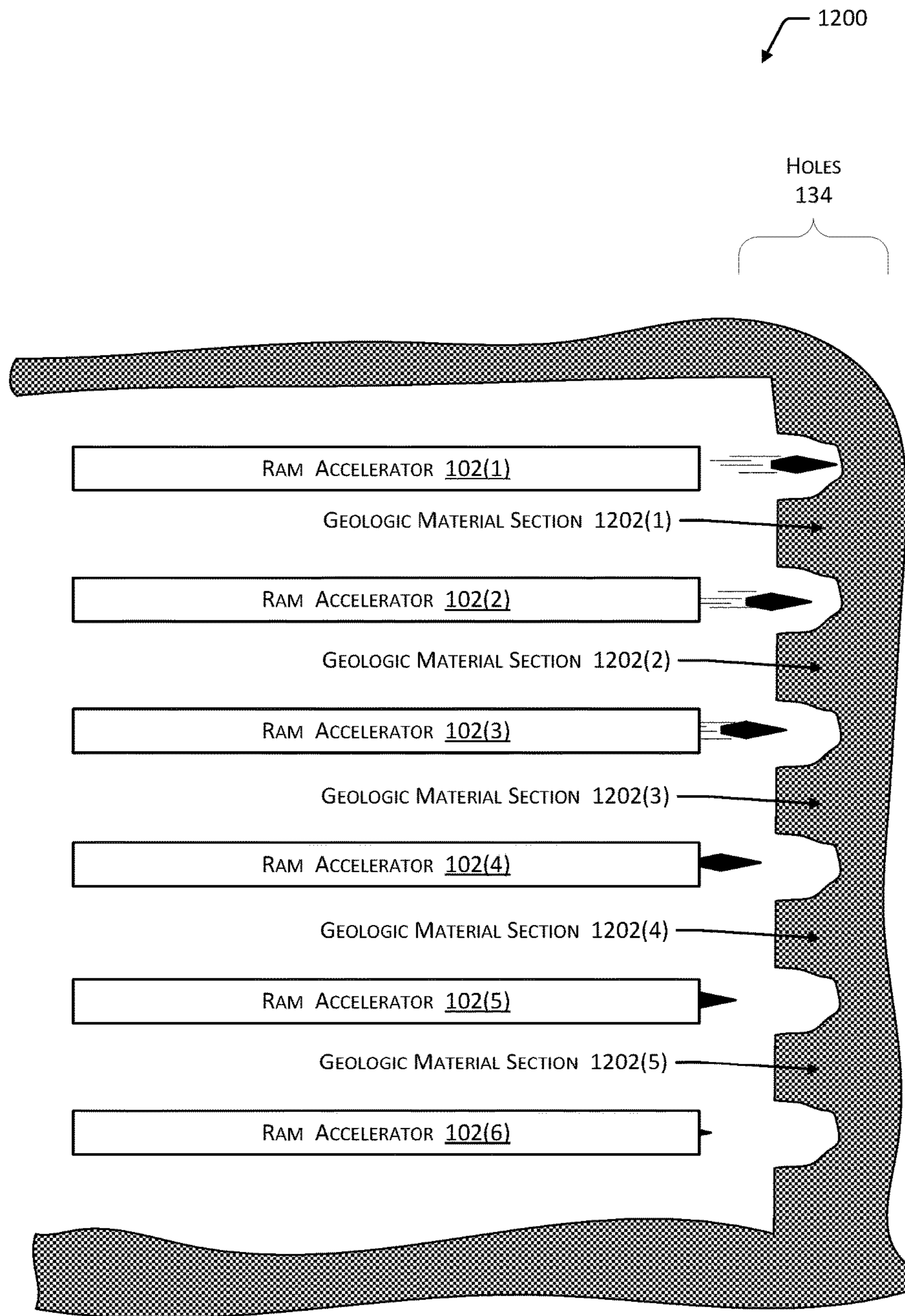

FIG. 12

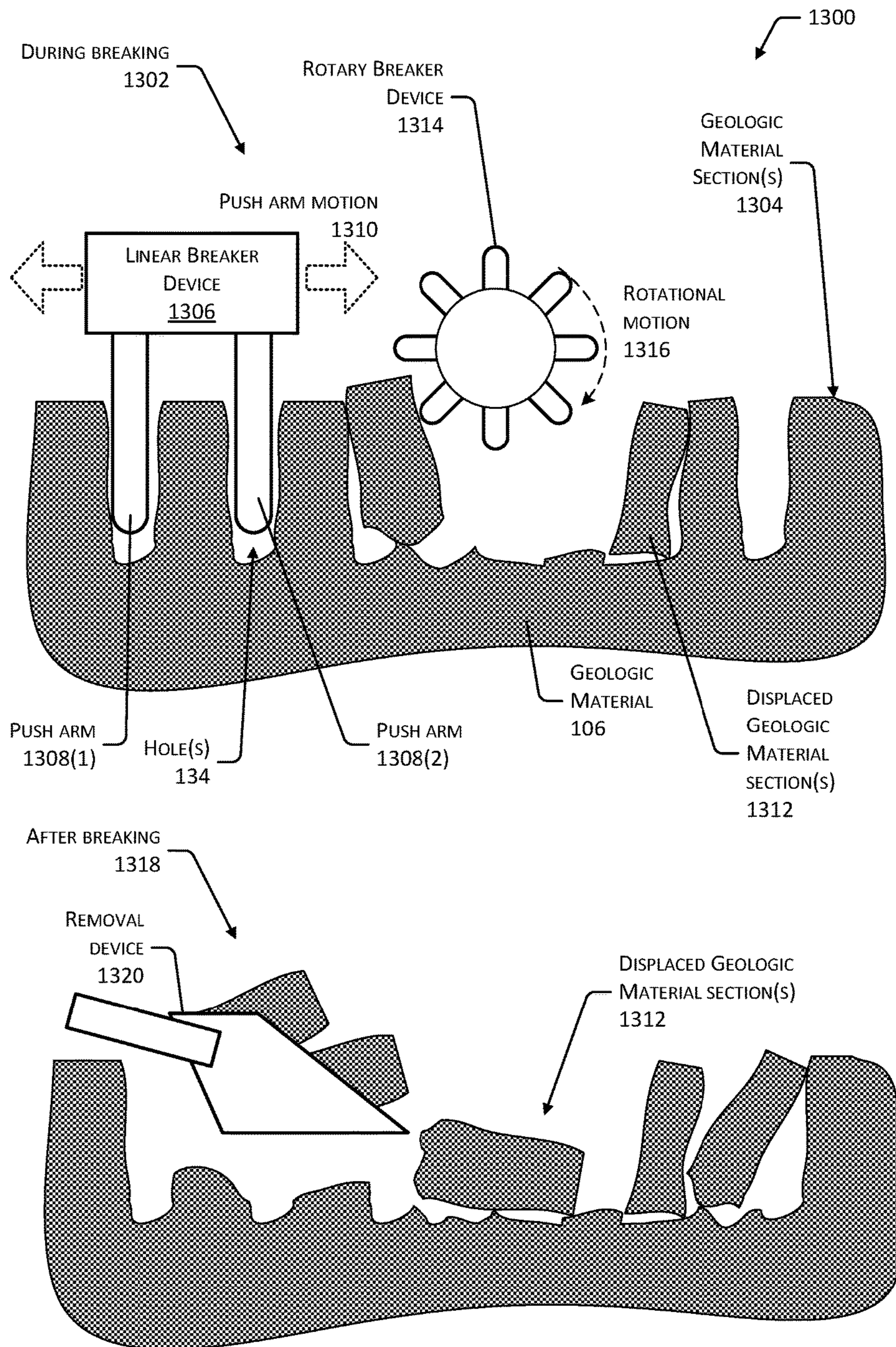

FIG. 13

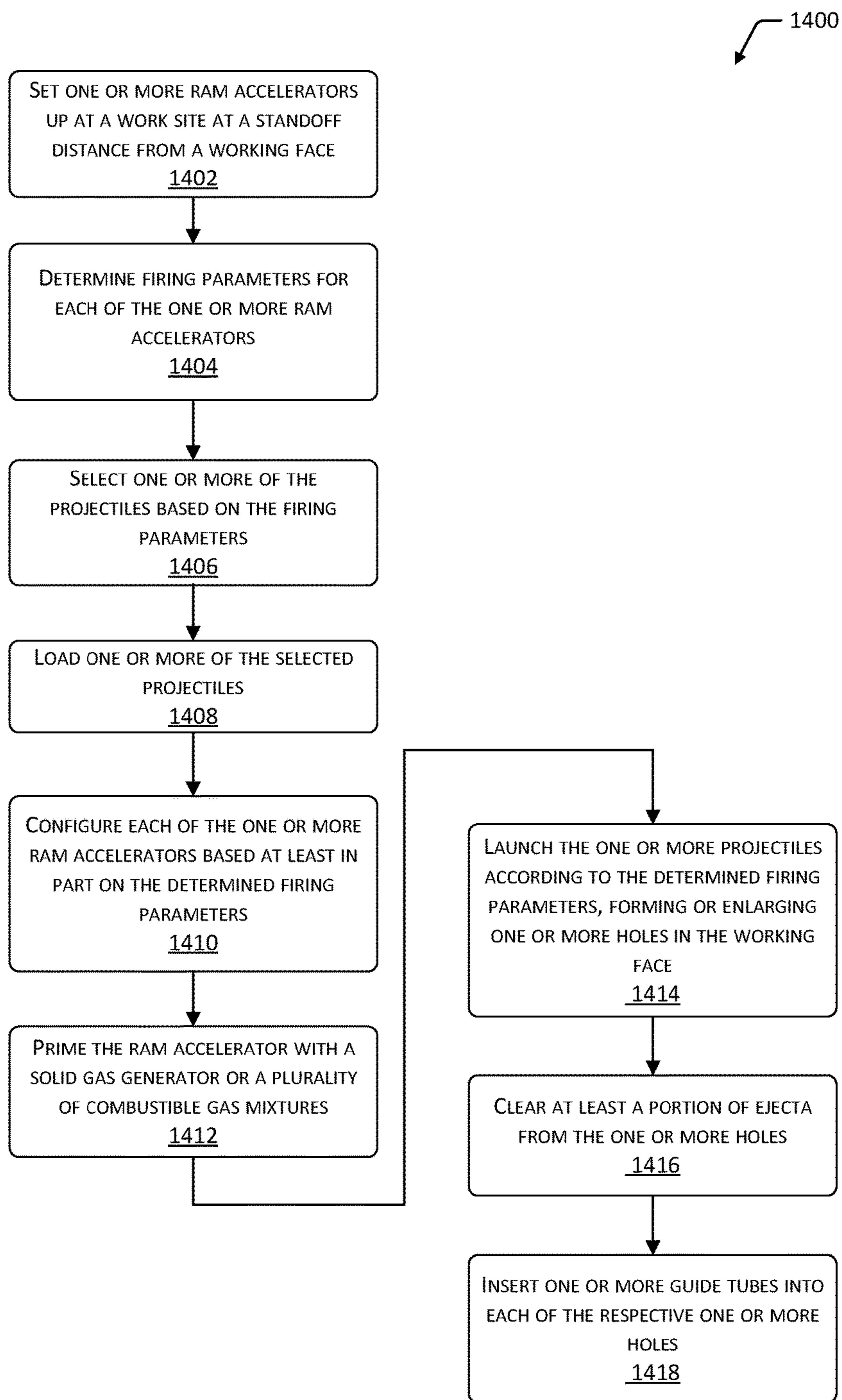

FIG. 14

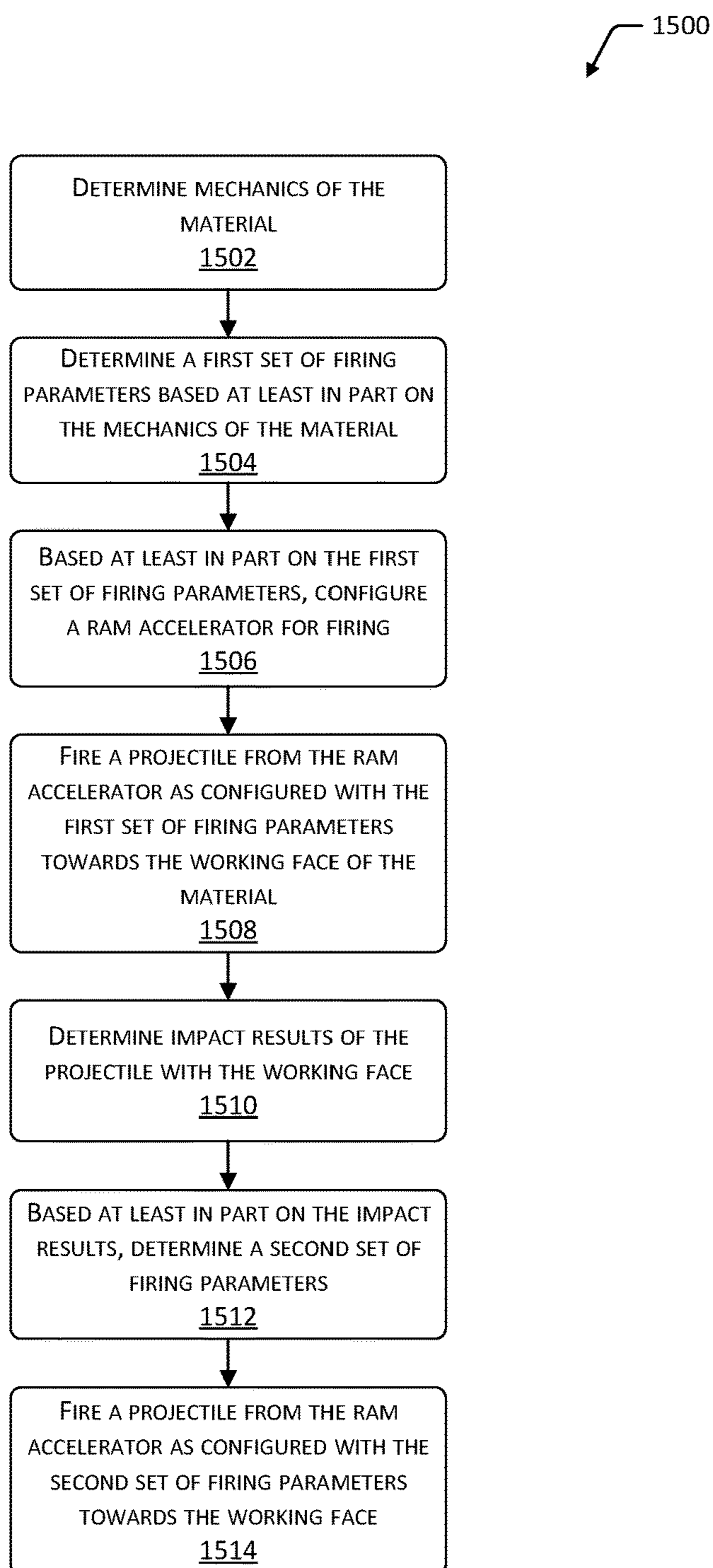

FIG. 15

RAM ACCELERATOR SYSTEM

PRIORITY

This application is a divisional of, and claims priority to, U.S. patent application Ser. No. 13/841,236, filed on Mar. 15, 2013, entitled "RAM ACCELERATOR SYSTEM," which is hereby incorporated by reference in its entirety.

BACKGROUND

Traditional drilling and excavation methods utilize drills to form holes in one or more layers of material to be penetrated. Excavation, quarrying, and tunnel boring may also use explosives placed in the holes and detonated in order to break apart at least a portion of the material. The use of explosives results in additional safety and regulatory burdens which increase operational cost. Typically these methods cycle from drill, blast, removal of material, ground support and are relative slow (many minutes to hours to days per linear foot is typical depending on the cross-sectional area being moved) methods for removing material to form a desired excavation.

BRIEF DESCRIPTION OF DRAWINGS

Certain implementations and embodiments will now be described more fully below with reference to the accompanying figures, in which various aspects are shown. However, various aspects may be implemented in many different forms and should not be construed as limited to the implementations set forth herein. The figures are not necessarily to scale, and the relative proportions of the indicated objects may have been modified for ease of illustration and not by way of limitation. Like numbers refer to like elements throughout.

FIG. 1 is an illustrative system for drilling or excavating using a ram accelerator comprising a plurality of sections holding one or more combustible gasses configured to propel a projectile towards a working face of material.

FIG. 2 illustrates a curved drilling path formed using ram accelerator drilling.

FIG. 3 illustrates a section separator mechanism configured to reset a diaphragm penetrated during launch of the projectile such that a seal is maintained between the sections of the ram accelerator.

FIG. 4 illustrates a projectile configured to be accelerated using a ram combustion effect.

FIG. 5 illustrates a projectile configured with an abrasive inner core configured to provide abrasion of the material upon and subsequent to impact.

FIG. 6 illustrates a fluid-fluid impact interaction of the projectile with the geological material.

FIG. 7 illustrates a non-fluid-fluid impact interaction of the projectile with the geological material.

FIG. 8 illustrates additional detail associated with the guide tube, as well as reamers and other devices which may be placed downhole.

FIG. 9 illustrates a guide tube placed downhole having an ejecta collector coupled to one or more ejecta channels configured to convey ejecta from the impact aboveground for disposal.

FIG. 10 illustrates a guide tube placed downhole having a reamer configured to be cooled by a fluid which is circulated aboveground to remove at least a portion of the ejecta.

FIG. 11 illustrates a guide tube placed downhole deploying a continuous concrete lining within the hole.

FIG. 12 illustrates tunnel boring or excavation using a ram accelerator to drill a plurality of holes using a plurality of projectiles.

FIG. 13 illustrates devices to remove rock sections defined by holes drilled by the ram accelerator projectiles.

FIG. 14 is a flow diagram of a process of drilling a hole using a ram accelerator.

FIG. 15 is a flow diagram of a process of multiple firings of a plurality of projectiles with firing patterns adjusted between at least some of the firings.

DETAILED DESCRIPTION

Conventional drilling and excavation techniques used for penetrating materials typically rely on mechanical bits used to cut or grind at a working face. These materials may include metals, ceramics, geologic materials, and so forth. Tool wear and breakage on the mechanical bits slows these operations, increasing costs. Furthermore, the rate of progress of cutting through material such as hard rock may be prohibitive. Drilling may be used in the establishment of water wells, oil wells, gas wells, underground pipelines, and so forth. Additionally, the environmental impact of conventional techniques may be significant. For example, conventional drilling may require a significant supply of water which may not be readily available in arid regions. As a result, resource extraction may be prohibitively expensive, time consuming, or both.

Described in this disclosure are systems and techniques for using a ram accelerator to eject one or more projectiles toward the working face of the geologic material. The ram accelerator includes a launch tube separated into multiple sections. Each of the sections is configured to hold one or more combustible gases. A projectile is boosted to a ram velocity down the launch tube and through the multiple sections. At the ram velocity, a ram compression effect provided at least in part by a shape of the projectile initiates combustion of the one or more combustible gasses in a ram combustion effect, accelerating the projectile. In some implementations, the projectile may accelerate to a hypervelocity. In some implementations, hypervelocity includes velocities greater than or equal to two kilometers per second upon ejection or exit from the ram accelerator launch tube. In other implementations, the projectile may accelerate to a non-hypervelocity. In some implementations, non-hypervelocity includes velocities below two kilometers per second.

The projectiles ejected from the ram accelerator strike a working face of the geologic material. Projectiles travelling at hypervelocity typically interact with the geologic material at the working face as a fluid-fluid interaction upon impact, due to the substantial kinetic energy in the projectile. This interaction forms a hole which is generally in the form of a cylinder. By firing a series of projectiles, a hole may be drilled through the geologic material. In comparison, projectiles travelling at non-hypervelocity interact with the geologic material at the working face as a solid-solid interaction. This interaction may fracture or fragment the geologic material, and may form a hole which is cylindrical or a crater having a conical profile.

A section separator mechanism is configured provide one or more barriers between the different sections in the ram accelerator which contain the one or more combustible gasses. Each section may be configured to contain one or more combustible gasses in various conditions such as particular pressures, and so forth. The section separator

mechanism may employ a diaphragm, valve, and so forth which is configured to seal one or more sections. During firing, the projectile passes through the diaphragm, breaking the seal, or the valve is opened prior to launch. A reel mechanism may be used to move an unused section of the diaphragm into place, restoring the seal. Other separator mechanisms such as ball valves, plates, gravity gradient, and so forth may also be used.

The hole formed by the impact of the projectiles may be further guided or processed. A guide tube may be inserted into the hole to prevent subsidence, direct a drilling path, deploy instrumentation, and so forth. In one implementation, a reamer or slip-spacer may be coupled to the guide tube and inserted downhole. The reamer may comprise one or more cutting or grinding surfaces configured to shape the hole into a substantially uniform cross section. For example, the reamer may be configured to smooth the sides of the hole.

The reamer may also be configured to apply lateral force between the guide tube and the walls of the hole, canting or otherwise directing the drill in a particular direction. This directionality enables the ram accelerator to form a curved drilling path.

The guide tube is configured to accept the projectiles ejected from the ram accelerator and direct them towards the working face. A series of projectiles may be fired from the ram accelerator down the guide tube, allowing for continuous drilling operations. Other operations may also be provided, such as inserting a continuous concrete liner into the hole.

Ejecta comprising materials resulting from the impact of the one or more projectiles with the geologic material may be removed from the hole. In some implementations, a back pressure resulting from the impact may force the ejecta from the hole. In some implementations a working fluid such as compressed air, water, and so forth may be injected into the hole to aid in removal of at least a portion of the ejecta. The injection may be done continuously, prior to, during, or after, each launch of the projectile.

One or more ram accelerators may also be deployed to drill several holes for tunnel boring, excavation, and so forth. A plurality of accelerators may be fired sequentially or simultaneously to strike one or more target points on a working face. After several holes are formed from projectile impacts, various techniques may be used to remove pieces of geologic material defined by two or more holes which are proximate to one another. Mechanical force may be applied by breaker arms to snap, break, or otherwise free pieces of the geologic material from a main body of the geologic material at the working face. In other implementations, conventional explosives may be placed into the ram accelerator drilled holes and detonated to shatter the geologic material.

In some implementations, conventional drilling techniques and equipment may be used in conjunction with ram accelerator drilling. For example, ram accelerator drilling may be used to reach a particular target depth. Once at the target depth, a conventional coring drill may be used to retrieve core samples from strata at the target depth.

The systems and techniques described may be used to reduce the time, costs, and environmental necessary for resource extraction, resource exploration, construction, and so forth. Furthermore, the capabilities of ram accelerator drilling enable deeper exploration and recovery of natural resources. Additionally, the energy released during impact may be used for geotechnical investigation such as reflection seismology, strata characterization, and so forth.

Illustrative Systems and Mechanisms

FIG. 1 is an illustrative system 100 for drilling or excavating using a ram accelerator 102. A ram accelerator 102 may be positioned at a standoff distance 104 from geologic material 106 or target material. The ram accelerator 102 has a body 108. The body 108 may comprise one or more materials such as steel, carbon fiber, ceramics, and so forth.

The ram accelerator 102 includes boost mechanism 110. The boost mechanism 110 may include one or more of a gas gun, electromagnetic launcher, solid explosive charge, liquid explosive charge, backpressure system, and so forth. The boost mechanism 110 may operate by providing a relative differential in speed between a projectile 118 and particles in the one or more combustible gasses which is equal to or greater than a ram velocity. The ram velocity is the velocity of the projectile 118, relative to particles in the one or more combustible gasses, at which the ram effect occurs. In some implementations, at least a portion of the launch tube 116 within the boost mechanism 110 may be maintained at a vacuum prior to launch.

In the example depicted here the boost mechanism comprises a detonation gas gun, including an igniter 112 coupled to a chamber 114. The chamber 114 may be configured to contain one or more combustible or explosive or detonable materials which, when triggered by the igniter 112, generate an energetic reaction. In the gas gun implementation depicted, the chamber 114 is coupled to a launch tube 116 within which the projectile 118 is placed. In some implementations, the projectile 118 may include or be adjacent to an obturator 120 configured to seal at least temporarily the chamber 114 from the launch tube 116. The obturator may be attached, integrated but frangible or separate from but in-contact with the projectile 118. One or more blast vents 122 may be provided to provide release of the reaction byproducts. In some implementations the launch tube 116 may be smooth, rifled, include one or more guide rails or other guide features, and so forth. The launch tube 116, or portions thereof, may be maintained at a pressure which is lower than that of the ambient atmosphere. For example, portions of the launch tube 116 such as those in the boost mechanism 110 may be evacuated to a pressure of less than 25 torr.

The boost mechanism 110 is configured to initiate a ram effect with the projectile 118. The ram effect results in compression of one or more combustible gasses by the projectile 118 and subsequent combustion proximate to a back side of the projectile 118. This compression results in heating of the one or more combustible gasses, triggering ignition. The ignited gasses combusting in an exothermic reaction, impart an impulse on the projectile 118 which is accelerated down the launch tube 116. In some implementations ignition may be assisted or initiated using a pyrotechnic igniter. The pyrotechnic igniter may either be affixed to or a portion of the projectile 118, or may be arranged within the launch tube 116.

The boost mechanism 110 may use an electromagnetic, solid explosive charge, liquid explosive charge, stored compressed gasses, and so forth to propel the projectile 118 along the launch tube 116 at the ram velocity. In some implementations a backpressure system may be used. The backpressure system accelerates at least a portion of the one or more combustible gasses past a stationary projectile 118, producing the ram effect in an initially stationary projectile 118. For example, the combustible gas mixture under high pressure may be exhausted from ports within the launch tube 116 past the projectile 118 as it rests within the launch tube 116. This relative velocity difference achieves the ram velocity, and the ram effect of combustion begins and pushes

5

the projectile **118** down the launch tube **116**. Hybrid systems may also be used, in which the projectile **118** is moved and backpressure is applied simultaneously.

The projectile **118** passes along the launch tube **116** from the boost mechanism **110** into one or more ram acceleration sections **124**. The ram acceleration sections **124** (or “sections”) may be bounded by section separator mechanisms **126**. The section separator mechanisms **126** are configured to maintain a combustible gas mixture **128** which has been admitted into the section **124** via one or more gas inlet valves **130** in the particular section **124**. Each of the different sections **124** may have a different combustible gas mixture **128**.

The section separator mechanisms **126** may include valves such as ball valves, diaphragms, gravity gradient, liquids, or other structures or materials configured to maintain the different combustible gas mixtures **128** substantially within their respective sections **124**. In one implementation described below with regard to FIG. **3**, the diaphragm may be deployed using a reel mechanism, allowing for relatively rapid reset of the diaphragms following their penetration by the projectile **118** during operation of the ram accelerator **102**. In other implementations the launch tube **116** may be arranged at an angle which is not perpendicular to local vertical, such that gravity holds the different combustible gas mixtures **128** at different heights, based on their relative densities. For example, lighter combustible gas mixtures **128** “float” on top of heavier combustible gas mixtures **128** which sink or remain on the bottom of the launch tube **116**. In another example, fluid at the bottom of the hole **134** may provide a seal which allows the guide tube **136** to be filled with a combustible gas mixture **128** and used as a ram acceleration section **124**.

In this illustration four sections **124(1)-(4)** are depicted, as maintained by five section separator mechanisms **126(1)-(5)**. When primed for operation, each of the sections **124(1)-(4)** are filled with the combustible gas mixtures **128(1)-(4)**. In other implementations, different numbers of sections **124**, section separator mechanisms **126**, and so forth may be used.

The combustible gas mixture **128** may include one or more combustible gasses. The one or more combustible gasses may include an oxidizer or an oxidizing agent. For example, the combustible gas mixture **128** may include hydrogen and oxygen gas in a ratio of 2:1. Other combustible gas mixtures may be used, such as silane and carbon dioxide. The combustible gas mixture **128** may be provided by extraction from ambient atmosphere, electrolysis of a material such as water, from a solid or liquid gas generator using solid materials which react chemically to release a combustible gas, from a previously stored gas or liquid, and so forth.

The combustible gas mixtures **128** may be the same or may differ between the sections **124**. These differences include chemical composition, pressure, temperature, and so forth. For example, the density of the combustible gas mixture **128** in each of the sections **124(1)-(4)** may decrease along the launch tube **116**, such that the section **124(1)** holds the combustible gas **128** at a higher pressure than the section **124(4)**. In another example, the combustible gas mixture **128(1)** in the section **124(1)** may comprise oxygen and propane while the combustible gas mixture **128(3)** may comprise oxygen and hydrogen.

One or more sensors **132** may be configured at one or more positions along the ram accelerator **102**. These sensors may include pressure sensors, chemical sensors, density

6

sensors, fatigue sensors, strain gauges, accelerometers, proximity sensors, and so forth.

The ram accelerator **102** is configured to eject the projectile **118** from an ejection end of the launch tube **116** and towards a working face of the geologic material **106** or other geologic material **106**. Upon impact, a hole **134** may be formed. The ejection end is the portion of the ram accelerator **102** which is proximate to the hole **134**.

A series of projectiles **118** may be fired, one after another, to form a hole which grows in length with each impact. The ram accelerator **102** may accelerate the projectile **118** to a hypervelocity. As used in this disclosure, hypervelocity includes velocities greater than or equal to two kilometers per second upon ejection or exit from the ram accelerator launch tube.

In other implementations, the projectile may accelerate to a non-hypervelocity. Non-hypervelocity includes velocities below two kilometers per second. Hypervelocity and non-hypervelocity may also be characterized based on interaction of the projectile **118** with the geologic material **106** or other geologic material **106s**. For example, hypervelocity impacts are characterized by a fluid-fluid type interaction, while non-hypervelocity impacts are not. These interactions are discussed below in more detail with regard to FIGS. **6** and **7**.

In some implementations a guide tube **136** may be inserted into the hole **134**. The interior of the guide tube **136** may be smooth, rifled, include one or more guide rails or other guide features, and so forth. The guide tube **136** provides a pathway for projectiles **118** to travel from the ram accelerator **102** to the portion of the geologic material **106** which are being drilled. The guide tube **136** may also be used to prevent subsidence, direct a drilling path, deploy instrumentation, deploy a reamer, and so forth. The guide tubes **136** may thus follow along a drilling path **138** which is formed by successive impacts of the projectiles **118**. The guide tube **136** may comprise a plurality of sections coupled together, such as with threads, clamps, and so forth. The guide tube **136** may be circular, oval, rectangular, triangular, or describe a polyhedron in cross section. The guide tube **136** may comprise one or more tubes or other structures which are nested one within another. For example, the guide tube **136** may include an inner tube and an outer tube which are mounted coaxially, or with the inner tube against one side of the outer tube.

Formation of the hole **134** using the impact of the projectiles **118** result in increased drilling speed compared to conventional drilling by minimizing work stoppages associated with adding more guide tube **136**. For example, following repeated firings, the standoff distance **104** may increase to a distance of zero to hundreds of feet. After extending the hole **134** using several projectiles **118**, firing may cease while one or more additional guide tube **136** sections are inserted. In comparison, conventional drilling may involve stopping every ten feet to add a new section of drill pipe, which results in slower progress.

The direction of the drilling path **138** may be changed by modifying one or more firing parameters of the ram accelerator **102**, moving the guide tube **136**, and so forth. For example, reamers on the guide tube **136** may exert a lateral pressure by pushing against the walls of the hole **134**, bending or tilting the guide tube **136** to a particular direction.

An ejecta collector **140** is configured to collect or capture at least a portion of ejecta which results from the impacts of the one or more projectiles **118**. The ejecta collector **140** may be placed proximate to a top of the hole **134**, such as coupled to the guide tube **136**.

In some implementations a drill chuck **142** may be mechanically coupled to the guide tube **136**, such that the guide tube **136** may be raised, lowered, rotated, tilted, and so forth. Because the geologic material **106** is being removed by the impact of the projectiles **118**, the end of the guide tube **136** is not carrying the loads associated with traditional mechanical drilling techniques. As a result, the drill chuck **142** with the ram accelerator system may apply less torque to the guide tube **136**, compared to conventional drilling.

The ram accelerator **102** may be used in conjunction with conventional drilling techniques. This is discussed in more detail below with regard to FIG. 2.

In some implementations an electronic control system **144** may be coupled to the ram accelerator **102**, the one or more sensors **132**, one or more sensors in the projectiles **118**, and so forth. The control system **144** may comprise one or more processors, memory, interfaces, and so forth which are configured to facilitate operation of the ram accelerator **102**. The control system **144** may couple to the one or more section separator mechanisms **126**, the gas inlet valves **130**, and the sensors **132** to coordinate the configuration of the ram accelerator **102** for ejection of the projectile **118**. For example, the control system **144** may fill particular combustible gas mixtures **128** into particular sections **124** and recommend a particular projectile **118** type to use to form a particular hole **134** in particular geologic material **106**.

Other mechanisms may be present which are not depicted here. For example, an injection system may be configured to add one or more materials into the wake of the projectiles **118**. These materials may be used to clean the launch tube **116**, clean the guide tube **136**, remove debris, and so forth. For example, powdered silica may be injected into the wake of the projectile **118**, such that at least a portion of the silica is pulled along by the wake down the launch tube **116**, into the hole **134**, or both.

In some implementations a drift tube may be positioned between the launch tube **116** and the guide tube **136** or the hole **134**. The drift tube may be configured to provide a consistent pathway for the projectile **118** between the two.

FIG. 2 illustrates a scenario **200** in which a curved drilling path **138** formed at least in part by ram accelerator drilling. In this illustration a work site is shown **202** at ground level **204**. At the work site **202**, a support structure **206** holds the ram accelerator **102**. For example, the support structure **206** may comprise a derrick, crane, scaffold, and so forth. In some implementations, the overall length of the ram accelerator **102** may be between 75 to 300 feet. The support structure **206** is configured to maintain the launch tube **116** in a substantially straight line, in a desired orientation during firing. By minimizing deflection of the launch tube **116** during firing of the projectile **118**, side loads exerted on the body **108** are reduced. In some implementations a plurality of ram accelerators **102** may be moved in and out of position in front of the hole **134** to fire their projectiles **118**, such that one ram accelerator **102** is firing while another is being loaded.

The ram accelerator **102** may be arranged vertically, at an angle, or horizontally, depending upon the particular task. For example, while drilling a well the ram accelerator **102** may be positioned substantially vertically. In comparison, while boring a tunnel the ram accelerator **102** may be positioned substantially horizontally.

The drilling path **138** may be configured to bend or curve along one or more radii of curvature. The radius of curvature may be determined based at least in part on the side loads imposed on the guide tube **136** during transit of the projectile **118** within.

The ability to curve allows the drilling path **138** to be directed such that particular points in space below ground level **204** may be reached, or to avoid particular regions. For example, the drilling path **138** may be configured to go around a subsurface reservoir. In this illustration, the drilling path **138** passes through several layers of geological strata **208**, to a final target depth **210**. At the target depth **210**, or at other points in the drilling path **138** during impacting, the ejecta from the impacts of the projectiles **118** may be analyzed to determine composition of the various geological strata **208** which the end of the drilling path **138** is passing through.

In some implementations the ram accelerator **102**, or a portion thereof may extend or be placed within the hole **134**. For example, the ram accelerator **102** may be lowered down the guide tube **136** and firing may commence at a depth below ground level. In another implementation, the guide tube **136**, or a portion thereof, may be used as an additional ram acceleration section **124**. For example, a lower portion of the guide tube **136** in the hole **134** may be filled with a combustible gas to provide acceleration prior to impact.

Drilling with the ram accelerator **102** may be used in conjunction with conventional drilling techniques. For example, the ram accelerator **102** may be used to rapidly reach a previously designated target depth **210** horizon. At that point, use of the ram accelerator **102** may be discontinued, and conventional drilling techniques may use the hole **134** formed by the projectiles **118** for operations such as cutting core samples and so forth. Once the core sample or other operation has been completed for a desired distance, use of the ram accelerator **102** may resume and additional projectiles **118** may be used to increase the length of the drilling path **138**.

In another implementation, the projectile **118** may be shaped in such a way to capture or measure in-flight the material characteristics of the geologic material **106** or analyze material interaction between material comprising the projectile **118** and the geologic material **106** or other target material. Samples of projectile **118** fragments may be recovered from the hole **134**, such as through core drilling and recovery of the projectile **118**. Also, sensors in the projectile **118** may transmit information back to the control system **144**.

FIG. 3 illustrates a mechanism **300** of one implementation of a section separator mechanism **126**. As described above, several techniques and mechanisms may be used to maintain the different combustible gas mixtures **128** within particular ram accelerator sections **124**.

The mechanism **300** depicted here may be arranged at one or more ends of a particular section **124**. For example, the mechanism **300** may be between the sections **124(1)** and **124(2)** as shown here, at the ejection end of the section **124(4)** which contains the combustible gas mixture **128(4)**, and so forth.

A gap **302** is provided between the ram accelerator sections **124**. Through the gap **302**, or in front of the launch tube **116** when on the ejection end, a diaphragm **304** extends. The diaphragm **304** is configured to maintain the combustible gas mixture **128** within the respective section, prevent ambient atmosphere from entering an evacuated section **124**, and so forth.

The diaphragm **304** may comprise one or more materials including, but not limited to, metal, plastic, ceramic, and so forth. For example, the diaphragm **304** may comprise aluminum, steel, copper, Mylar, and so forth. In some implementations, a carrier or supporting matrix or structure may be arranged around at least a portion of the diaphragm **304**

which is configured to be penetrated by the projectile 118 during firing. The portion of the diaphragm 304 which is configured to be penetrated may differ in one or more ways from the carrier. For example, the carrier may be thicker, have a different composition, and so forth. In some implementations the portion of the diaphragm 304 which is configured to be penetrated may be scored or otherwise designed to facilitate penetration by the projectile 118.

A supply spool 306 may store a plurality of diaphragms 304 in a carrier strip, or a diaphragm material, with penetrated diaphragms being taken up by a takeup spool 308.

A seal may be maintained between the section 124 and the diaphragm 304 by compressing a portion of the diaphragm 304 or the carrier holding the diaphragm 304 between a first sealing assembly 310 on the first ram accelerator section 124(1) and a corresponding second sealing assembly 312 on the second ram accelerator section 124(2). The second sealing assembly 312 is depicted here as being configured to be displaced as indicated along the arrow 314 toward or away from the first sealing assembly 310, to allow for making or breaking the seal and movement of the diaphragm 304.

During evacuation or filling of the section 124 with the combustible gas mixture 128, the intact diaphragm 304 as sealed between the first sealing assembly 310 and the second sealing assembly 312 seals the section 124. During the firing process, the projectile 118 penetrates the diaphragm 304, leaving a hole. After firing, material may be spooled from the supply spool 306 to the takeup spool 308, such that an intact diaphragm 304 is brought into the launch tube 116 and subsequently sealed by the sealing assemblies.

A housing 316 may be configured to enclose the spools, sealing assembly, and so forth. Various access ports or hatches may be provided which allow for maintenance such as removing or placing the supply spool 306, the takeup spool 308, and so forth. A separation joint 318 may be provided which allows for separation of the first ram accelerator section 124(1) from the second ram accelerator section 124(2). The housing 316, the separation joint 318, and other structures may be configured to maintain alignment of the launch tube 116 during operation. The housing 316 may be configured with one or more pressure relief valves 320. These valves 320 may be used to release pressure resulting from operation of the ram accelerator 102, changes in atmospheric pressure, and so forth.

While the first ram accelerator section 124(1) from the second ram accelerator sections 124(2) are depicted in this example, it is understood that the mechanism 300 may be employed between other sections 124, at the end of other sections 124, and so forth.

In other implementations, instead of a spool, the diaphragm 304 may be arranged as plates or sheets of material. A feed mechanism may be configured to change these plates or sheets to replace penetrated diaphragms 304 with intact diaphragms.

The section separator mechanism 126 may comprise a plate configured to be slid in and out of the launch tube 116, such as a gate valve. Other valves such as ball valves may also be used. One or more of these various mechanisms may be used in the same launch tube 116 during the same firing operation. For example, the mechanism 300 may be used at the ejection end of the ram accelerator 102 while ball or gate valves may be used between the sections 124.

The section separator mechanisms 126 may be configured to fit within the guide tube 136, or be placed down within the hole 134. This arrangement allows the ram acceleration sections 124 to extend down the hole 134. For example, the

mechanism 300 may be deployed down into the hole 134 such as an ongoing sequence of projectiles 118 may be fired down the hole.

FIG. 4 illustrates several views 400 of the projectile 118. A side-view 402 depicts the projectile 118 as having a front 404, a back 406, a rod penetrator 408, and inner body 410, and an outer body 412. The front 404 is configured to exit the launch tube 116 before the back 406 during launch.

The rod penetrator 408 may comprise one or more materials such as metals, ceramics, plastics, and so forth. For example, the rod penetrator 408 may comprise copper, depleted uranium, and so forth.

The inner body 410 of the projectile 118 may comprise a solid plastic material or other material to entrain into the hole 134 such as, for example, explosives, hole cleaner, seepage stop, water, ice. A plastic explosive or specialized explosive may be embedded in the rod penetrator 408. As the projectile 118 penetrates the geologic material 106, the explosive is entrained into the hole 134 where it may be detonated. In another embodiment, the outer shell body 412 may be connected to a lanyard train configured to pull a separate explosive into the hole 134.

In some implementations, at least a portion of the projectile 118 may comprise a material which is combustible during conditions present during at least a portion of the firing sequence of the ram accelerator 102. For example, the outer shell body 412 may comprise aluminum. In some implementations, the projectile 118 may omit onboard propellant.

The back 406 of the projectile 118 may also comprise an obturator 120 which is adapted to prevent the escape of the combustible gas mixture 128 past the projectile 118 as the projectile 118 accelerates through each section of the launch tube 116. The obturator 120 may be an integral part of the projectile 118 or a separate and detachable unit. Cross section 414 illustrates a view along the plane indicated by line A-A.

As depicted, the projectile 118 may also comprise one or more fins 416, rails, or other guidance features. For example, the projectile 118 may be rifled to induce spiraling. The fins 416 may be positioned to the front 404 of the projectile 118, the back 406, or both, to provide guidance during launch and ejection. The fins 416 may be coated with an abrasive material that aids in cleaning the launch tube 116 as the projectile 118 penetrates the geologic material 106. In some implementations one or more of the fin 416 may comprise an abrasive tip 418. In some implementations, the body of the projectile 118 may extend out to form a fin or other guidance feature. The abrasive tip 418 may be used to clean the guide tube 136 during passage of the projectile 118.

In some implementations the projectile 118 may incorporate one or more sensors or other instrumentation. The sensors may include accelerometers, temperature sensors, gyroscopes, and so forth. Information from these sensors may be returned to receiving equipment using radio frequencies, optical transmission, acoustic transmission, and so forth. This information may be used to modify the one or more firing parameters, characterize material in the hole 134, and so forth.

FIG. 5 illustrates several views 500 of another projectile 118 design. As shown here in a side view 502 showing a cross section, the projectile 118 has a front 504 and a back 506.

Within the projectile 118 is the rod penetrator 408. While the penetrator is depicted as a rod, in other implementations the penetrator may have one or more other shapes, such as a prismatic solid.

11

Similar to that described above, the projectile **118** may include a middle core **507** and an outer core **508**. In some implementations one or both of these may be omitted. As also described above, the projectile **118** may include the inner body **410** and the outer shell body **412**, albeit with a different shape from that described above with regard to FIG. **4**.

The projectile **118** may comprise a pyrotechnic igniter **510**. The pyrotechnic igniter **510** may be configured to initiate, maintain, or otherwise support combustion of the combustible gas mixtures **128** during firing.

Cross section **512** illustrates a view along the plane indicated by line B-B. As depicted, the projectile **118** may not be radially symmetrical. In some implementations the shape of the projectile **118** may be configured to provide guidance or direction to the projectile **118**. For example, the projectile **118** may have a wedge or chisel shape. As above, the projectile **118** may also comprise one or more fins **416**, rails, or other guidance features.

The projectile **118** may comprise one or more abrasive materials. The abrasive materials may be arranged within or on the projectile **118** and configured provide an abrasive action upon impact with the working face of the geologic material **106**. The abrasive materials may include diamond, garnet, silicon carbide, tungsten, or copper. For example, a middle core **507** may comprise an abrasive material that may be layered between the inner core and the outer core **508** of the rod penetrator **408**.

FIG. **6** illustrates a sequence **600** of a fluid-fluid impact interaction such as occurring during penetration of the working face of the geologic material **106** by the projectile **118** that has been ejected from the ram accelerator **102**. In this illustration time is indicated as increasing down the page, as indicated by arrow **602**.

In one implementation, a projectile **118** with a length to diameter ratio of approximately 10:1 or more is impacted at high velocity into the working surface of a geologic material **106**. Penetration at a velocity above approximately 800 meters/sec results in a penetration depth that is on the order of two or more times the length of the projectile **118**. Additionally, the diameter of the hole **134** created is approximately twice the diameter of the impacting projectile **118**. Additional increases in velocity of the projectile **118** result in increases in penetration depth of the geologic material **106**. As the velocity of the projectile **118** increases, the front of the projectile **118** starts to mushroom on impact with the working face of the geologic material **106**. This impact produces a fluid-fluid interaction zone **604** which results in erosion or vaporization of the projectile **118**. A back pressure resulting from the impact may force ejecta **606** or other material such as cuttings from the reamers from the hole **134**. The ejecta **606** may comprise particles of various sizes ranging from a fine dust to chunks. In some implementations the ejecta **606** may comprise one or more materials which are useful in other industrial processes. For example, ejecta **606** which include carbon may comprise buckyballs or nanoparticles suitable for other applications such as medicine, chemical engineering, printing, and so forth.

The higher the velocity, the more fully eroded the projectile **118** becomes and therefore the “cleaner” or emptier the space created by the high-speed impact, leaving a larger diameter and a deeper hole **134**. Also, the hole **134** will have none or almost no remaining material of the projectile **118**, as the projectile **118** and a portion of the geologic material **106** has vaporized.

FIG. **7** illustrates a sequence **700** of a non-fluid-fluid interaction such as occurring during penetration of the

12

working face of the geologic material **106** by the projectile **118** at lower velocities. In this illustration time is indicated as increasing down the page, as indicated by arrow **702**.

At lower velocities, such as when the projectile **118** is ejected from the ram accelerator **102** at a velocity below 2 kilometers per second, the portion of the geologic material **106** proximate to the projectile **118** starts to fracture in a fracture zone **704**. Ejecta **606** may be thrown from the impact site. Rather than vaporizing the projectile **118** and a portion of the geologic material **106** as occurs with the fluid-fluid interaction, here the impact may pulverize or fracture pieces of the geological material **106**.

As described above, a back pressure resulting from the impact may force the ejecta **606** from the hole **134**.

FIG. **8** illustrates a mechanism **800** including the guide tube **136** equipped with an inner tube **802** and an outer tube **804**. Positioning of the inner tube **802** relative to the outer tube **804** may be maintained by one or more positioning devices **806**. In some implementations the positioning device **806** may comprise a collar or ring. The positioning device **806** may include one or more apertures or pathways to allow materials such as fluid, ejecta **606**, and so forth, to pass. The positioning device **806** may be configured to allow for relative movement between the inner tube **802** and the outer tube **804**, such as rotation, translation, and so forth.

The space between the inner guide tube **802** and the outer guide tube **804** may form one or more fluid distribution channels **808**. The fluid distribution channels **808** may be used to transport ejecta **606**, fluids such as cooling or hydraulic fluid, lining materials, and so forth. The fluid distribution channels **808** are configured to accept fluid from a fluid supply unit **810** via one or more fluid lines **812**. The fluid distribution channels **808** may comprise a coaxial arrangement of one tube within another, the jacket comprising the space between an inner tube **802** and an outer tube **804**. The fluid may be recirculated in a closed, or used once in an open loop.

The inner tube **802** is arranged within the outer tube **804**. In some implementations the tubes may be collinear with one another. Additional tubes may be added, to provide for additional functionality, such as additional fluid distribution channels **808**.

One or more reamers **814** are coupled to the fluid distribution channels **814** and arranged in the hole **134**. The reamers **814** may be configured to provide various functions. These functions may include providing a substantially uniform cross section of the hole **134** by cutting, scraping, grinding, and so forth. Another function provided by the reamer **814** may be to act as a bearing between the walls of the hole **134** and the guide tube **136**. The fluid from the fluid supply unit **810** may be configured to cool, lubricate, and in some implementations power the reamers **814**.

The reamers **814** may also be configured with one or more actuators or other mechanisms to produce one or more lateral movements **816**. These lateral movements **816** displace at least a portion of the guide tube **136** relative to the wall of the hole **134**, tilting, canting, or curving one or more portions of the guide tube **136**. As a result, the impact point of the projectile **118** may be shifted. By selectively applying lateral movements **816** at one or more reamers **814** within the hole **134**, the location of subsequent projectile **118** impacts and the resulting direction of the drilling path **138** may be altered. For example, the drilling path **138** may be curved as a result of the lateral movement **816**.

The reamers **814**, or other supporting mechanisms such as rollers, guides, collars, and so forth, may be positioned along

the guide tube **136**. These mechanisms may prevent or minimize Euler buckling of the guide tube **136** during operation.

In some implementations, a path of the projectile **118** may also be altered by other mechanisms, such as a projectile director **818**. The projectile director **818** may be arranged at one or more locations, such as the guide tube **136**, at an end of the guide tube **136** proximate to the working face of the geologic material **106**, and so forth. The projectile director **818** may include a structure configured to deflect or shift the projectile **118** upon exit from the guide tube **136**.

As described above, the guide tube **136**, or the ram accelerator **102** when no guide tube is in use, may be separated from the working face of the geologic material **106** by the standoff distance **104**. The standoff distance **104** may vary based at least in part on depth, material in the hole **134**, firing parameters, and so forth. In some implementations the standoff distance **104** may be two or more feet.

As drilling progresses, additional sections of guide tube **136** may be coupled to those which are in the hole **134**. As shown here, the guide tube **136(1)** which is in the hole **134** may be coupled to a guide tube **136(2)**. In some implementations the inner tubes **802** and the outer tubes **804** may be joined in separate operations. For example, the inner tube **802(2)** may be joined to the inner tube **802(1)** in the hole **134**, one or more positioning devices **806** may be emplaced, and the outer tube **804(2)** may be joined also to the outer tube **804(1)**.

FIG. **9** illustrates a mechanism **900** in which a fluid such as exhaust from the firing of the ram accelerator **102** is used to drive ejecta **606** or other material such as cuttings from the reamers **814** from the hole **134**. In this illustration, the guide tube **136** is depicted with the one or more reamers **814**. The fluid distribution channels **808** or other mechanisms described herein may also be used in conjunction with the mechanism **900**.

Ram accelerator exhaust **902** (“exhaust”) or another working fluid is forced down the guide tube **136**. The working fluid may include air or other gasses, water or other fluids, slurries, and so forth under pressure. The exhaust **902** pushes ejecta **606** into one or more ejecta transport channels **904**. In one implementation, the ejecta transport channels **904** may comprise a space between the guide tube **136** and the walls of the hole **134**. In another implementation the ejecta transport channels **904** may comprise a space between the guide tube **136** and another tube coaxial with the guide tube **136**. The ejecta transport channels **904** are configured to carry the ejecta **606** from the hole **134** out to the ejecta collector **140**.

A series of one-way valves **906** may be arranged within the ejecta transport channels **904**. The one-way valves **906** are configured such that the exhaust **902** and the ejecta **606** are able to migrate away from a distal end of the hole **134**, towards the ejecta collector **140**. For example, a pressure wave produced by the projectile **118** travelling down the guide tube **136** forces the ejecta **606** along the ejecta transport channels **904**, past the one-way valves **906**. As the pressure subsides, larger pieces of ejecta **606** may fall, but are prevented from returning to the end of the hole **134** by the one-way valves **906**. With each successive pressure wave resulting from the exhaust **902** of successive projectiles **118** or other injections or another working fluid, the given pieces of ejecta **606** migrate past successive one-way valves **906** to the surface. At the surface, the ejecta collector **140** transports the ejecta **606** for disposal.

The ejecta **606** at the surface may be analyzed to determine composition of the geologic material **106** in the hole

134. In some implementations, the projectile **118** may be configured with a predetermined element or tracing material, such that analysis may be associated with one or more particular projectiles **118**. For example, coded taggants may be injected into the exhaust **902**, placed on or within the projectile **118**, and so forth.

FIG. **10** illustrates a mechanism **1000** for using fluid to operate the reamers **814** or other devices in the hole **134** and remove ejecta **606**. As described above, the guide tube **136** may be equipped with one or more fluid distribution channels **808**. The fluid distribution channels **808** may be configured to provide fluid from the fluid supply unit **810** to one or more devices or outlets in the hole **134**.

In this illustration, one or more of the reamers **814** are configured to include one or more fluid outlet ports **1002**. The fluid outlet ports **1002** are configured to emit at least a portion of the fluid from the fluid distribution channels **808** into the hole **134**. This fluid may be used to carry away ejecta **606** or other material such as cuttings from the reamers **814**. As described above, a series of one-way valves **906** are configured to direct the ejecta **606** or other debris towards the ejecta collector **140**. In some implementations, fluid lift assist ports **1004** may be arranged periodically along the fluid distribution channels **808**. The fluid lift assist ports **1004** may be configured to assist the movement of the ejecta **606** or other debris towards the ejecta collector **140** by providing a jet of pressurized fluid. The fluid outlet ports **1002**, the fluid lift assist ports **1004**, or both may be metered to provide a fixed or adjustable flow rate.

The motion of the fluid containing the ejecta **606** or other debris from the fluid outlet ports **1002** and the fluid lift assist ports **1004** may work in conjunction with pressure from the exhaust **902** to clear the hole **134** of ejecta **606** or other debris. In some implementations various combinations of projectile **118** may be used to pre-blast or clear the hole **134** of debris prior to firing of a particular projectile **118**.

As described above, the ram accelerator **102** may work in conjunction with conventional drilling techniques. In one implementation, the end of the guide tube **136** in the hole **134** may be equipped with a cutting or guiding bit. For example, a coring bit may allow for core sampling.

FIG. **11** illustrates a mechanism **1100** in which a lining is deployed within the hole **134**. A concrete delivery jacket **1102** or other mechanism such as piping is configured to accept concrete from a concrete pumping unit **1104** via one or more supply lines **1106**. The concrete flows through the concrete delivery jacket **1102** to one or more concrete outlet ports **1108** within the hole **134**. The concrete is configured to fill the space between the walls of the hole **134** and the guide tube **136**. Instead of, or in addition to concrete, other materials such as Bentonite, agricultural straw, cotton, thickening agents such as guar gum, xanthan gum, and so forth may be used.

As drilling continues, such as from successive impacts of projectile **118** fired by the ram accelerator **102**, the guide tube **136** may be inserted further down into the hole **134**, and the concrete may continue to be pumped and extruded from the concrete outlet ports **1108**, forming a concrete lining **1110**. In other implementations, material other than concrete may be used to provide the lining of the hole **134**.

In some implementations, a seal **1112** may be provided to minimize or prevent flow of concrete into the working face of the hole **134** where the projectiles **118** are targeted to impact. The mechanisms **1100** may be combined with the other mechanisms described herein, such as the reamer mechanisms **800**, the ejecta **606** removal mechanisms **900** and **1000**, and so forth.

In one implementation the concrete may include a release agent or lubricant. The release agent may be configured to ease motion of the guide tube **136** relative to the concrete lining **1110**. In another implementation, a release agent may be emitted from another set of outlet ports. A mechanism may also be provided which is configured to deploy a disposable plastic layer between the guide tube **136** and the concrete lining **1110**. This layer may be deployed as a liquid or a solid. For example, the plastic layer may comprise polytetrafluoroethylene (“PTFE”), polyethylene, and so forth.

FIG. **12** illustrates a mechanism **1200** for tunnel boring or excavation using one or more ram accelerators **102**. A plurality of ram accelerators **102(1)-(N)** may be fired sequentially or simultaneously to strike one or more target points on the working face, forming a plurality of holes **134**. The impacts may be configured in a predetermined pattern which generates one or more focused shock waves within a geological material **106**. These shock waves may be configured to break or displace the geological material **106** which is not vaporized on impact.

As shown here, six ram accelerators **102(1)-(6)** are arranged in front of the working face. One or more projectiles **118** are launched from each of the ram accelerators **102**, forming corresponding holes **134(1)-(6)**. The plurality of ram accelerators **102(1)-(N)** may be moved in translation, rotation, or both, either as a group or independently, to target and drill the plurality of holes **134** in the working face of the geologic material **106**.

In another implementation, a single ram accelerator **102** may be moved in translation, rotation, or both, to target and drill the plurality of holes **134** in the working face of the geologic material **106**.

After the holes **134** are formed from impacts of the projectiles **118**, various techniques may be used to remove pieces or sections of geologic material **106**. The sections of geologic material **1202** are portions of the geologic material **106** which are defined by two or more holes which are proximate to one another. For example, four holes **134** arranged in a square define a section of the geologic material **106** which may be removed, as described below with regard to FIG. **13**.

As described above, use of the ram accelerated projectile **118** allows for rapid formation of the holes **134** in the geologic material **106**. This may result in reduced time and cost associated with tunnel boring.

FIG. **13** illustrates devices and processes **1300** to remove rock sections defined by holes drilled by the ram accelerator projectiles **118** or conventional drilling techniques. During breaking **1302**, the ram accelerator **102** may include a mechanism which breaks apart the geologic material sections **1304**. For example, the ram accelerator **102** may comprise a linear breaker device **1306** that includes one or more push-arms **1308** that move according to a push-arm motion **1310**. The push-arms **1308** may be inserted between the geologic material sections **1304** and mechanical force may be applied by push arms **1308** to snap, break, or otherwise free pieces of the geologic material **106** from a main body of the geologic material **106** at the working face, forming displaced geologic material sections **1312**.

In some implementations a rotary breaker device **1314** that moves according to the rotary motion **1316** may be used instead of, or in addition to, the linear breaker device **1306**. The rotary breaker device **1314** breaks apart the geologic material sections **1304** by applying mechanical force during rotation. After breaking **1318**, a removal device **1320** trans-

ports the displaced geologic material sections **1312** from the hole **134**. For example, the removal device **1320** may comprise a bucket loader.

Illustrative Processes

FIG. **14** is flow diagram **1400** of an illustrative process **1400** of penetrating geologic material **106** utilizing a hyper velocity ram accelerator **102**. At block **1402**, one or more ram accelerators **102** are set up at a work site **202** to drill several holes **134** for tunnel boring, excavation, and so forth. The ram accelerators **102** may be positioned vertically, horizontally, or diagonally at a stand-off distance from the working face of the geologic material **106** to be penetrated.

At block **1404**, once the ram accelerators **102** are positioned, the firing parameters, such as for example, projectile **118** type and composition, hardness and density of the geologic material **106**, number of stages in the respective ram accelerator **102**, firing angle as well as other ambient conditions including air pressure, temperature, for each of the ram accelerators **102** is determined. At block **1406**, upon a determination of the firing parameters one or more projectiles **118** is selected based at least in part on the firing parameters and the selected one or more projectiles **118** is loaded into the ram accelerator **102** as described at block **1408**.

At block **1410**, each of the ram accelerators **102** is configured based at least in part on the determined firing parameters. At block **1412**, each of the ram accelerators **102** is then primed with either a solid gas generator or a plurality of combustible gas mixtures **128**. At block **1414**, after priming the one or more ram accelerators **102**, one or more of the loaded projectiles **118** is launched according to the determined firing parameters. For example, a projectile **118** is boosted to a ram velocity down the launch tube **116** and through the multiple sections **124** and ejected from the ram accelerator **102** forming or enlarging one or more holes **134** in the working face of the geologic material **106**.

At **1416** at least a portion of ejecta **606** is cleared from the one or more holes **134**. For example, as described above, a back pressure resulting from the impact may force the ejecta **606** from the hole **134**. In some implementations a working fluid such as compressed air, water, and so forth may be injected into the hole **134** to aid in removal of at least a portion of the ejecta **606**. Each of the holes **134** formed by the impact of the projectile **118** at hypervelocity may be further processed. At block, **1418**, a guide tube **136** may be inserted into the hole **134** to prevent subsidence, deploy instrumentation, and so forth. In one implementation, a reamer **814** coupled to a guide tube **136** may be inserted down the hole **134** and configured to provide a substantially uniform cross section.

FIG. **15** is an illustrative process **1500** of penetrating geologic material **106** utilizing a hyper velocity ram accelerator **102** to fire multiple projectiles **118** down a single hole **134** such that the hole **134** is enlarged as subsequent projectile **118** penetrate deeper into the geologic material **106**. At block **1502**, the mechanics of the geologic material **106** is determined. At block **1504**, an initial set of firing parameters is determined based at least in part on the mechanics of the geologic material **106**. At block **1506**, the ram accelerator **102** is configured for firing based at least in part on the initial set of firing parameters. Once the ram accelerator **102** is configured, at block **1508**, the projectile **118** is fired toward the working face of the geologic material **106** forming one or more holes **134**. At block **1510**, the impact results of the projectile **118** with the working face are determined. In some embodiments, the ram accelerator **102** may need to be reconfigured before loading and firing a

17

subsequent projectile **118** into the hole **134**. At block **1512**, a second of firing parameters is determined based at least in part on the impact results. At block **1514**, a subsequent projectile **118** is fired from the ram accelerator **102** as configured with the second set of firing parameters towards the working face of the geologic material **106**. This process may be repeated until the desired penetration depth is reached.

Additional Applications

The ram accelerator **102** may also be used in industrial applications as well, such as in material production, fabrication, and so forth. In these applications a target may comprise materials such as metal, plastic, wood, ceramic, and so forth. For example, during shipbuilding large plates of high strength steel may need to have holes created for piping, propeller shafts, hatches, and so forth. The ram accelerator **102** may be configured to fire one or more of the projectiles **118** through one or more pieces of metal, to form the holes. Large openings may be formed by a plurality of smaller holes around a periphery of the desired opening. Conventional cutting methods such as plasma torches, saws, and so forth may then be used to remove remaining material and finalize the opening for use. In addition to openings, the impact of the projectiles **118** may also be used to form other features such as recesses within the target. The use of the ram accelerator **102** in these industrial applications may thus enable fabrication with materials which are difficult to cut, grind, or otherwise machine.

Furthermore, the projectile **118** may be configured such that during the impact, particular materials are deposited within the impact region. For example, the projectile **118** may comprise carbon such that, upon impact with the target, a diamond coating from the pressures of the impact are formed on the resulting surfaces of the opening. A backstop or other mechanism may be provided to catch the ejecta portions of the projectile **118** post-impact, and so forth. For example, the ram accelerator **102** may be configured to fire through the target material and towards a pool of water.

Those having ordinary skill in the art will readily recognize that certain steps or operations illustrated in the figures above can be eliminated, combined, subdivided, executed in parallel, or taken in an alternate order. Moreover, the methods described above may be implemented as one or more software programs for a computer system and are encoded in a computer-readable storage medium as instructions executable on one or more processors. Separate instances of these programs can be executed on or distributed across separate computer systems.

Although certain steps have been described as being performed by certain devices, processes, or entities, this need not be the case and a variety of alternative implementations will be understood by those having ordinary skill in the art.

Additionally, those having ordinary skill in the art readily recognize that the techniques described above can be utilized in a variety of devices, environments, and situations. Although the present disclosure is written with respect to specific embodiments and implementations, various changes and modifications may be suggested to one skilled in the art and it is intended that the present disclosure encompass such changes and modifications that fall within the scope of the appended claims.

What is claimed is:

1. A system comprising:

a control system to determine one or more firing parameters;

18

one or more ram accelerators configured based at least in part on the one or more firing parameters, each of the one or more ram accelerators comprising:

a projectile that comprises an outer core covering at least a portion of an inner core, the inner core comprises one or more non-gaseous materials configured to provide an abrasive action upon impact, wherein the one or more non-gaseous materials comprises one or more of:

diamond,
garnet,
silicon carbide,
tungsten, or
copper;

a plurality of sensors configured to communicate with the control system;

a plurality of ventless sections separated by section separation mechanisms, wherein each of the sections is configured to contain one or more combustible gasses; and

a ventless boost mechanism attached to the plurality of ventless sections, the ventless boost mechanism configured to impart an impulse on the projectile such that the projectile is accelerated to a ram-effect velocity within the plurality of ventless sections.

2. The system of claim 1, wherein an end of the plurality of ventless sections is at least partially in contact with one or more of a geologic material or a fluid in a hole formed by impact of the projectile.

3. The system of claim 1, further comprising a concrete delivery jacket coupled to a guide tube and configured to inject a liquid concrete mixture into a space between the concrete delivery jacket and walls of a hole formed by impact of the projectile.

4. The system of claim 1, further comprising a positioning device affixed to at least a portion of at least one of the ventless sections, the positioning device configured to direct a path of a hole by directing exit of the projectile.

5. The system of claim 1, wherein the projectile comprises one or more sensors that transmit data; and the system further comprising a receiver; and the control system uses the data received using the receiver to determine the one or more firing parameters.

6. The system of claim 1, the section separation mechanism comprising:

a diaphragm dispenser attached to the plurality of ventless sections, the diaphragm dispenser configured to move a diaphragm material through a gap between the plurality of ventless sections of the ram accelerator.

7. The system of claim 1, further comprising one or more cutting bits.

8. The system of claim 1, the control system further configured to fire a plurality of ram accelerators in a predetermined pattern configured to generate one or more focused shock waves within a target material.

9. The system of claim 1, wherein composition of the combustible gasses of the plurality of ventless sections differ.

10. The system of claim 1, wherein the one or more firing parameters comprise one or more of:

projectile type,
projectile composition,
projectile density,
hardness of target material,
density of the target material,
number of the plurality of ventless sections,

19

number of the one or more ram accelerators in use, ambient conditions, or firing angle.

11. A system comprising:

one or more ram accelerators, each of the one or more ram accelerators comprising:

a projectile that comprises an outer core covering at least a portion of an inner core, the inner core comprises one or more non-gaseous materials configured to provide an abrasive action upon impact, wherein the one or more non-gaseous materials comprises one or more of:

- diamond,
- garnet,
- silicon carbide,
- tungsten, or
- copper;

a plurality of ventless sections separated by section separation mechanisms; and

a ventless boost mechanism attached to the plurality of ventless sections that imparts an impulse on the projectile such that the projectile is accelerated to a ram-effect velocity.

12. The system of claim 11, wherein the section separation mechanism comprises a valve.

13. The system of claim 11, further comprising:

- a plurality of sensors in the projectile that generate data; and
- a control system that determines one or more firing parameters based at least in part on the data.

14. The system of claim 11, further comprising a mechanism proximate to a downhole end of the one or more ram accelerators that exerts a lateral force between a portion of the one or more ram accelerators and a wall of a hole.

15. The system of claim 11, further comprising:

- a section separation mechanism comprising:
 - a supply spool to store diaphragm material;
 - a takeup spool to retain used diaphragm material; and

20

one or more sealing assemblies to maintain a seal between a portion of the diaphragm material and at least one of the plurality of ventless sections during operation.

16. A system comprising:

a ram accelerator comprising:

a projectile that comprises an outer core covering at least a portion of an inner core, the inner core comprises one or more non-gaseous materials configured to provide an abrasive action upon impact, wherein the one or more non-gaseous materials comprises one or more of:

- diamond,
- garnet,
- silicon carbide,
- tungsten, or
- copper;

a plurality of ventless sections; and

a ventless boost mechanism attached to at least one of the plurality of ventless sections, wherein the ventless boost mechanism accelerates the projectile to a ram-effect velocity.

17. The system of claim 16, wherein at least a portion of the plurality of ventless sections are separated by section separation mechanisms.

18. The system of claim 17, wherein the section separation mechanism comprises a ball valve.

19. The system of claim 17, the section separation mechanism comprising:

a diaphragm dispenser that moves a diaphragm material through a gap between the plurality of ventless sections of the ram accelerator.

20. The system of claim 16, wherein the projectile is further configured to entrain into a hole one or more of:

- an explosive,
- hole cleaner,
- seepage stop,
- water, or
- ice.

* * * * *