



US010154675B2

(12) **United States Patent**
Robinson et al.

(10) **Patent No.:** **US 10,154,675 B2**
(45) **Date of Patent:** **Dec. 18, 2018**

(54) **SOLUBLE COFFEE PRODUCTS FOR PRODUCING BEVERAGES WITH ENHANCED FLAVORS AND AROMAS**

(71) Applicant: **Starbucks Corporation**, Seattle, WA (US)

(72) Inventors: **Urano A. Robinson**, Sammamish, WA (US); **J. Marcio Da Cruz**, Seattle, WA (US)

(73) Assignee: **Starbucks Corporation**, Seattle, WA (US)

(*) Notice: Subject to any disclaimer, the term of this patent is extended or adjusted under 35 U.S.C. 154(b) by 0 days.

(21) Appl. No.: **13/834,317**

(22) Filed: **Mar. 15, 2013**

(65) **Prior Publication Data**

US 2013/0260004 A1 Oct. 3, 2013

Related U.S. Application Data

(60) Continuation of application No. 13/207,962, filed on Aug. 11, 2011, now Pat. No. 8,414,953, which is a division of application No. 12/170,396, filed on Jul. 9, 2008, now Pat. No. 8,043,645.

(51) **Int. Cl.**
A23F 5/40 (2006.01)
A23C 9/142 (2006.01)

(52) **U.S. Cl.**
CPC *A23F 5/405* (2013.01); *A23C 9/142* (2013.01)

(58) **Field of Classification Search**
CPC *A23F 5/405*; *A23C 9/142*
See application file for complete search history.

(56) **References Cited**

U.S. PATENT DOCUMENTS

1,836,931 A	12/1931	Meyer et al.	
2,062,109 A *	11/1936	Rogers	A23F 5/04 241/12
2,110,732 A	3/1938	Kane	
2,224,942 A	12/1940	Weisman	
2,454,510 A	11/1948	Heyman et al.	
2,557,294 A	6/1951	Kellogg et al.	
2,650,034 A	8/1953	Wiemer	
2,955,768 A	3/1959	Engi	
3,261,689 A	7/1966	Ponzoni	
3,532,507 A	10/1970	Cascione et al.	
3,544,331 A	12/1970	Hair	

(Continued)

FOREIGN PATENT DOCUMENTS

AR	088680 A1	4/2013
AR	084533 A1	5/2013

(Continued)

OTHER PUBLICATIONS

“Composition of Milk Products”, N.E.M. Business Solutions. Values from “Composition of Foods” USDA Handbook No. 8, rev. 1976.

(Continued)

Primary Examiner — Anthony Weier

(74) *Attorney, Agent, or Firm* — Knobbe Martens Olson & Bear LLP

(57) **ABSTRACT**

The present embodiments generally relate to beverages with enhanced flavors and aromas and method of making same. Some embodiments of the present disclosure are directed to soluble coffee and methods of making soluble coffee with improvements in such qualities as taste and aroma.

38 Claims, 3 Drawing Sheets

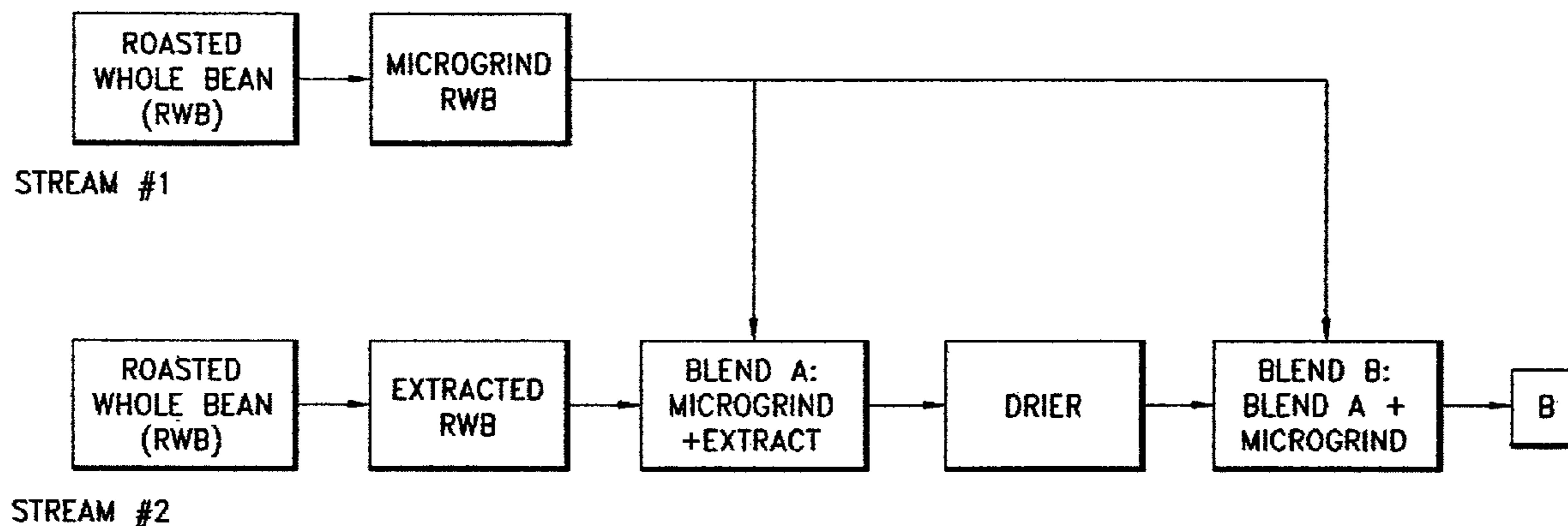

(56)

References Cited

U.S. PATENT DOCUMENTS

- 2007/0042083 A1 2/2007 Norton et al.
2007/0042097 A1 2/2007 Norton et al.
2007/0062375 A1 3/2007 Liverani et al.
2007/0068395 A1 3/2007 Masek et al.
2007/0071869 A1 3/2007 Knitel et al.
2007/0116850 A1 5/2007 Fujii et al.
2007/0160726 A1 7/2007 Fujii et al.
2007/0186784 A1 8/2007 Liverani et al.
2007/0186941 A1 8/2007 Holton, Jr. et al.
2007/0199453 A1 8/2007 Ramussen et al.
2007/0224331 A1 9/2007 Agarwala et al.
2007/0231443 A1 10/2007 Goto et al.
2007/0237846 A1 10/2007 Agarwala et al.
2007/0237857 A1 10/2007 Mullins et al.
2007/0248731 A1 10/2007 Curti et al.
2008/0003337 A1 1/2008 Ramussen et al.
2008/0008776 A1 1/2008 Back et al.
2008/0008780 A1 1/2008 Streekstra
2008/0038409 A1 2/2008 Nair et al.
2008/0038437 A1 2/2008 Paulig
2008/0044539 A1 2/2008 Perlman et al.
2008/0069924 A1 3/2008 Zeller et al.
2008/0096969 A1 4/2008 Ley
2008/0099509 A1 5/2008 Mount Joy
2008/0107786 A1 5/2008 Barnekow et al.
2008/0113073 A1 5/2008 Ley et al.
2008/0113077 A1 5/2008 Leloup et al.
2008/0131843 A1 6/2008 Montgomery et al.
2008/0138770 A1 6/2008 Montgomery
2008/0148955 A1 6/2008 Neace et al.
2008/0152768 A1 6/2008 Lan et al.
2008/0152779 A1 6/2008 De Groote et al.
2008/0160134 A1 7/2008 Hestekin et al.
2008/0160139 A1 7/2008 Imison et al.
2008/0160151 A1 7/2008 Zeller et al.
2008/0166451 A1 7/2008 Bel-Rhliid et al.
2008/0171108 A1 7/2008 Dierikx
2008/0175800 A1 7/2008 Schoening et al.
2008/0178743 A1 7/2008 Hug et al.
2008/0187638 A1 8/2008 Hansen
2008/0193625 A1 8/2008 Kawamura et al.
2008/0201241 A1 8/2008 Pecoraro
2008/0202345 A1 8/2008 Delonghi
2008/0213406 A1 9/2008 Stock et al.
2008/0213425 A1 9/2008 Asano et al.
2008/0214675 A1 9/2008 Ley et al.
2008/0215607 A1 9/2008 Kaushansky et al.
2008/0216666 A1 9/2008 Doglioni Majer
2008/0220052 A1 9/2008 Tsujita et al.
2008/0220140 A1 9/2008 Ley et al.
2008/0220147 A1 9/2008 Barrera Rivera et al.
2008/0227832 A1 9/2008 Oka et al.
2008/0227866 A1 9/2008 Ley et al.
2008/0227867 A1 9/2008 Ley et al.
2008/0233056 A1 9/2008 Berl
2008/0233265 A1 9/2008 Hibi
2008/0234174 A1 9/2008 Hoelscher
2008/0242740 A1 10/2008 Ley et al.
2008/0245236 A1 10/2008 Ternite et al.
2008/0249189 A1 10/2008 Atwal et al.
2008/0254169 A1 10/2008 MacMahon et al.
2008/0254175 A1 10/2008 Fujimoto
2008/0260893 A1 10/2008 Giffard et al.
2008/0260927 A1 10/2008 Steenhof et al.
2008/0260928 A1 10/2008 MacMahon et al.
2008/0264268 A1 10/2008 Tjen
2008/0273868 A1 11/2008 Boussemart et al.
2008/0274257 A1 11/2008 Caro et al.
2008/0280023 A1 11/2008 Kalenian
2008/0286388 A1 11/2008 Shiao
2008/0289509 A1 11/2008 Kodden et al.
2008/0293609 A1 11/2008 Artiga Gonzalez et al.
2008/0295697 A1 12/2008 Kim
2008/0299271 A1 12/2008 Inoue et al.
2008/0299283 A1 12/2008 Penson et al.
2008/0305052 A1 12/2008 Ley et al.
2008/0311245 A1 12/2008 Silver et al.
2008/0311271 A1 12/2008 Sugimoto et al.
2008/0311386 A1 12/2008 Wendt
2008/0314254 A1 12/2008 Terada
2008/0317923 A1 12/2008 Ley et al.
2008/0317924 A1 12/2008 Yang
2008/0317929 A1 12/2008 Popplewell et al.
2008/0317931 A1 12/2008 Mandralis et al.
2009/0004335 A1 1/2009 MacMahon et al.
2009/0005342 A1 1/2009 Takao et al.
2009/0007792 A1 1/2009 Glucksman et al.
2009/0007793 A1 1/2009 Glucksman et al.
2009/0011091 A1 1/2009 Bovetto et al.
2009/0011095 A1 1/2009 Yamane et al.
2009/0020018 A1 1/2009 Melzer et al.
2009/0022855 A1 1/2009 Steenhof et al.
2009/0022864 A1 1/2009 Steenhof et al.
2009/0029023 A1 1/2009 Kerler et al.
2009/0035421 A1 2/2009 Yamane et al.
2009/0035437 A1 2/2009 Bovetto et al.
2009/0041864 A1 2/2009 Warlick
2009/0053381 A1 2/2009 Fukuda et al.
2009/0061048 A1 3/2009 Kohane et al.
2009/0068337 A1 3/2009 Bringe et al.
2009/0074919 A1 3/2009 Smith
2009/0126577 A1 5/2009 Ternite
2009/0162489 A1 6/2009 Singh
2009/0175986 A1 7/2009 Doglioni Majer
2009/0186144 A1 7/2009 Chin
2009/0191320 A1 7/2009 Gu et al.
2009/0211458 A1 8/2009 Denisart et al.
2009/0232944 A1 9/2009 MacMahon et al.
2009/0246326 A1 10/2009 Cary et al.
2009/0252850 A1 10/2009 Gaonkar et al.
2009/0258118 A1 10/2009 Gillian
2009/0258132 A1 10/2009 Westhoff et al.
2009/0274632 A1 11/2009 Li et al.
2009/0311384 A1 12/2009 MacMahon et al.
2009/0317531 A1 12/2009 Reh et al.
2010/0009039 A1 1/2010 Robinson et al.
2010/0040733 A1 2/2010 Chin
2010/0040757 A1 2/2010 Chin
2010/0043644 A1 2/2010 Suggi Liverani et al.
2010/0043645 A1 2/2010 Suggi Liverani et al.
2010/0043646 A1 2/2010 Suggi Liverani et al.
2010/0055290 A1 3/2010 Schmidt et al.
2010/0080886 A1 4/2010 Araki et al.
2010/0104717 A1 4/2010 Zeller
2010/0112181 A1 5/2010 Taylor et al.
2010/0119685 A1 5/2010 Van Bergen
2010/0136178 A1 6/2010 Rapparini
2010/0136183 A1 6/2010 Gonus et al.
2010/0173053 A1 7/2010 Ryser et al.
2010/0173056 A1 7/2010 Yoakim et al.
2010/0178389 A1 7/2010 Jia et al.
2010/0178391 A1 7/2010 MacMahon et al.
2010/0178392 A1 7/2010 Yoakim et al.
2010/0183790 A1 7/2010 Zapp et al.
2010/0186599 A1 7/2010 Yoakim et al.
2010/0209582 A1 8/2010 Wyss et al.
2010/0215818 A1 8/2010 Kessler et al.
2010/0239710 A1 9/2010 Cary et al.
2010/0239734 A1 9/2010 Yoakim et al.
2010/0275787 A1 11/2010 Bonacci et al.
2010/0278995 A1 11/2010 Boehm et al.
2010/0291278 A1 11/2010 Lavie et al.
2010/0310727 A1 12/2010 Massey et al.
2010/0313766 A1 12/2010 Suggi Liverani et al.
2011/0008514 A1 1/2011 Spelman et al.
2011/0039007 A1 2/2011 Boehm et al.
2011/0086137 A1 4/2011 Robinson et al.
2011/0091609 A1 4/2011 Robinson et al.
2011/0091610 A1 4/2011 Robinson et al.
2011/0097458 A1 4/2011 Imison
2011/0135802 A1 6/2011 Robinson et al.
2011/0135803 A1 6/2011 Robinson et al.
2011/0293791 A1 12/2011 Robinson et al.
2012/0100258 A1 4/2012 Robinson et al.

(56)

References Cited

U.S. PATENT DOCUMENTS

2012/0100261 A1 4/2012 Robinson et al.
 2012/0107457 A1 5/2012 Robinson et al.
 2012/0164277 A1 6/2012 Robinson et al.
 2012/0164298 A1 6/2012 Robinson et al.
 2012/0164299 A1 6/2012 Robinson et al.

FOREIGN PATENT DOCUMENTS

AR 088278 A1 5/2014
 AT 368 839 B 11/1982
 AU 2009269041 2/2015
 BR 11 2014 008361-4 10/2014
 CA 989246 A1 5/1976
 CA 1099579 A1 4/1981
 CA 1110104 A1 10/1981
 CA 1274115 A1 9/1990
 CA 2031362 A1 6/1992
 CA 2074441 A1 2/1993
 CA 2090169 A1 9/1993
 CA 2216852 A1 4/1998
 CA 2241489 A1 1/1999
 CA 2281411 A1 3/2000
 CA 2289178 A1 5/2000
 CA 2317799 A1 3/2001
 CA 2423681 A1 5/2002
 CA 2427549 A1 11/2003
 CA 2533021 A1 1/2005
 CA 2515079 A1 2/2006
 CA 2614668 A1 1/2007
 CA 2810553 3/2013
 CA 2810556 3/2013
 CA 2810607 3/2013
 CA 2811121 3/2013
 CA 2729182 6/2013
 CN 1081829 A 2/1994
 CN 1170686 A 1/1998
 CN 1393147 A 1/2003
 CN 1466885 A 1/2004
 CN 1545898 A 11/2007
 CN 101347154 A 1/2009
 CN 102088863 A 6/2011
 CN 103338646 A 10/2013
 CN 103549092 A 2/2014
 CN 104105408 A 10/2014
 CO 4658 7/2014
 CO 5372 9/2014
 CZ 20020664 A3 7/2002
 DE 16 92 238 A1 10/1971
 DE 197 00 084 A1 7/1990
 DE 198 26 143 A1 12/1999
 DE 20 2006 000 618 U1 4/2006
 EP 0 159 754 A3 10/1985
 EP 0 195 574 B1 9/1986
 EP 0 220 889 A2 5/1987
 EP 0 220 889 B1 5/1987
 EP 0 813 815 A1 12/1987
 EP 0 144 785 B1 7/1988
 EP 0 205 244 B1 11/1988
 EP 0 299 106 B1 1/1989
 EP 0 175 521 B1 3/1989
 EP 0 216 971 B1 5/1989
 EP 0 213 247 B1 11/1989
 EP 0 215 164 B1 12/1989
 EP 0 396 260 A2 11/1990
 EP 0 224 338 B1 4/1991
 EP 0 227 263 B1 4/1991
 EP 0 420 509 A1 4/1991
 EP 0 220 889 B1 6/1991
 EP 0 466 955 A1 1/1992
 EP 0 323 592 B1 6/1992
 EP 0 240 754 B1 8/1992
 EP 0 326 740 B1 7/1993
 EP 0 554 008 A2 8/1993
 EP 0 560 609 A 9/1993
 EP 0 532 631 B1 12/1993

EP 0 482 236 B1 2/1994
 EP 0 489 402 B1 4/1994
 EP 0 474 005 B1 7/1994
 EP 0 458 310 B1 9/1994
 EP 0 509 257 B1 12/1994
 EP 0 354 810 B1 2/1995
 EP 0 489 401 B1 3/1995
 EP 0 499 023 B1 4/1995
 EP 0 526 766 B1 6/1995
 EP 0 538 512 B1 10/1995
 EP 0 532 959 B1 11/1995
 EP 0 700 640 B1 3/1996
 EP 0 574 034 B1 3/1997
 EP 0 891 715 A1 1/1999
 EP 0 893 065 A2 1/1999
 EP 0 928 561 A1 7/1999
 EP 0 985 350 A2 3/2000
 EP 0 778 735 B1 10/2000
 EP 0 874 557 B1 11/2000
 EP 0 826 308 B1 12/2000
 EP 1 078 575 A2 2/2001
 EP 1 133 932 A1 9/2001
 EP 0 888 066 B1 10/2001
 EP 1 201 135 A1 5/2002
 EP 0 885 566 B1 9/2002
 EP 0 809 443 B1 10/2002
 EP 0 973 406 B1 1/2003
 EP 1 199 948 B1 10/2003
 EP 1 374 690 A1 1/2004
 EP 1 198 992 A1 9/2004
 EP 1 069 830 B1 10/2004
 EP 1 000 548 B1 1/2005
 EP 1 135 992 B1 11/2005
 EP 1 195 574 B1 11/2005
 EP 1 600 461 A1 11/2005
 EP 1 704 781 A1 9/2006
 EP 1 726 213 A1 11/2006
 EP 1 736 063 A1 12/2006
 EP 1 977 651 A1 4/2007
 EP 1 538 924 B1 9/2007
 EP 1 370 483 B1 4/2008
 EP 1 911 354 A1 4/2008
 EP 1 917 860 A1 5/2008
 EP 1 917 864 A1 5/2008
 EP 1 925 208 A1 5/2008
 EP 1 363 501 B1 6/2008
 EP 1 645 636 B1 6/2008
 EP 1 645 637 B1 6/2008
 EP 1 932 457 A1 6/2008
 EP 1 949 828 A1 7/2008
 EP 1 435 793 B1 8/2008
 EP 1 558 118 B1 9/2008
 EP 1 967 076 A1 9/2008
 EP 1 726 536 B1 10/2008
 EP 1 745 702 B1 10/2008
 EP 1 761 150 B1 10/2008
 EP 1 980 258 A1 10/2008
 EP 1 985 213 A1 10/2008
 EP 1 557 091 B1 11/2008
 EP 1 679 979 B1 11/2008
 EP 1 708 579 B1 11/2008
 EP 1 987 727 A1 11/2008
 EP 1 990 286 A1 11/2008
 EP 1 617 729 B1 12/2008
 EP 1 797 772 B1 12/2008
 EP 2 000 034 A2 12/2008
 EP 2 000 062 A1 12/2008
 EP 2 008 938 A1 12/2008
 EP 1 759 597 B1 1/2009
 EP 2 011 406 A1 1/2009
 EP 2 178 388 B1 3/2011
 EP 2 443 937 A1 4/2012
 EP 2 443 938 A2 4/2012
 EP 2 654 441 10/2013
 EP 2 676 549 A2 12/2013
 EP 2 765 863 8/2014
 FR 2 662 584 A1 12/1991
 GB 1915 02332 A 5/1916
 GB 161920 A 4/1920

(56)

References Cited

FOREIGN PATENT DOCUMENTS

GB 1 027 926 A 4/1966
 GB 1027926 * 4/1966
 GB 2 006 603 A 5/1979
 GB 2 022 394 A 12/1979
 GB 1 564 094 A 4/1980
 GB 2 074 008 A 10/1981
 GB 2 334 659 A 9/1999
 HK 1157144 A 6/2012
 HK 1169790 A 2/2013
 HK 1169791 A 2/2013
 HK 1190039 A 7/2014
 HK 14108031.8 10/2014
 IN 154041 9/1984
 IN 4706/KOLNP/2010 A 2/2011
 JP S53-020466 2/1978
 JP 54-076866 A2 6/1979
 JP 56-094148 A 7/1981
 JP 61-239841 A 10/1986
 JP 02276536 A 11/1990
 JP 06-038681 A 2/1994
 JP 55-026887 A 2/1994
 JP 62-96457 A 10/1994
 JP 07-274835 A 10/1995
 JP 10-066507 A 3/1998
 JP 2000-333611 A 12/2000
 JP 2004-121138 A 4/2004
 JP 2005-124486 A 5/2005
 JP 2005-318812 A 11/2005
 JP 2006-520607 A 9/2006
 JP 41-82471 B2 11/2008
 JP 5721625 4/2015
 JP 59-03052 B2 4/2016
 JP 60-33364 B1 11/2016
 JP 61-03893 3/2017
 KR 2002-0026267 4/2002
 KR 10-2004-0082227 A 9/2004
 MX 295337 1/2012
 MX MX/a/2013007125 12/2013
 MY 154624 A 7/2015
 NZ 245739 A 8/1994
 NZ 244595 A 4/1995
 NZ 589957 10/2012
 NZ 621200 8/2015
 RU 2400098 C1 9/2010
 RU 2 495 582 C2 10/2013
 RU 2013 125 563 A 12/2014
 SG 192486 9/2013
 SG 192487 10/2013
 UA 104592 C2 2/2014
 WO WO 91/18517 A1 12/1991
 WO WO 94/10852 A1 5/1994
 WO WO 96/05737 A1 2/1996
 WO WO 96/24255 A1 8/1996
 WO WO 97/33482 A1 9/1997
 WO WO 98/06274 A1 2/1998
 WO WO 98/34495 A1 8/1998
 WO WO 99/52378 A1 10/1999
 WO WO 01/08507 A1 2/2001
 WO WO 2001/13735 3/2001
 WO WO 2008/002492 3/2001
 WO WO 02/34063 A1 5/2002
 WO WO 02/35939 A1 5/2002
 WO WO 02/074096 A2 9/2002
 WO WO 03/011041 A1 2/2003
 WO WO 03/032743 A1 4/2003
 WO WO 03/055633 A1 4/2003
 WO WO 04/082391 A1 9/2004
 WO WO 04/095937 A1 11/2004
 WO WO 05/000031 A2 1/2005
 WO WO 05/039313 A1 5/2005
 WO WO 05/122780 A1 12/2005

WO WO 06/020613 A1 2/2006
 WO WO 06/022540 A1 3/2006
 WO WO 06/125505 A1 11/2006
 WO WO 07/002062 A1 1/2007
 WO WO 07/011531 A1 1/2007
 WO WO 07/116350 A1 10/2007
 WO WO 08/047347 A2 4/2008
 WO WO 08/052952 A1 5/2008
 WO WO 08/062886 A1 5/2008
 WO WO 08/067101 A2 6/2008
 WO WO 08/071613 A1 6/2008
 WO WO 08/071744 A2 6/2008
 WO WO 08/082817 A1 7/2008
 WO WO 08/082953 A1 7/2008
 WO WO 08/103157 A2 8/2008
 WO WO 08/107281 A2 9/2008
 WO WO 08/107348 A1 9/2008
 WO WO 08/116021 A1 9/2008
 WO WO 08/123775 A1 10/2008
 WO WO 08/129035 A2 10/2008
 WO WO 08/129053 A1 10/2008
 WO WO 08/130990 A1 10/2008
 WO WO 08/132705 A1 11/2008
 WO WO 08/139205 A2 11/2008
 WO WO 08/148601 A1 12/2008
 WO WO 08/148604 A1 12/2008
 WO WO 08/148650 A1 12/2008
 WO WO 08/148656 A1 12/2008
 WO WO 08/148834 A1 12/2008
 WO WO 09/002724 A1 12/2008
 WO WO 09/006374 A2 1/2009
 WO WO 09/006379 A2 1/2009
 WO WO 09/007246 A2 1/2009
 WO WO 09/012524 A1 1/2009
 WO WO 10/005297 A1 1/2010
 WO WO 10/005604 A1 1/2010
 WO WO 2010/033023 3/2010
 WO WO 10/043332 A1 4/2010
 WO WO 10/068093 A1 6/2010
 WO WO 10/071425 A2 6/2010
 WO WO 10/112359 A1 10/2010
 WO WO 10/115697 A1 10/2010
 WO WO 10/116138 A1 10/2010
 WO WO 12/087585 A1 6/2012
 WO WO 2013/055633 5/2014

OTHER PUBLICATIONS

Meiyun, Song: "Study of Production Control and Quality Improvement of Instant Coffee", Science and Technology of Food Industry, vol. 23, No. 7, pp. 87-88, 2002.
 Food Safety Magazine, Jun./Jul. 2012, 84 pages.
 Knockaert, et al., "Effect of high pressure sterilization on nutritional quality of carrot products," InsideFood Symposium, Apr. 9-12, 2013, Leuven, Belgium.
 U.S. Department of Health and Human Services, Grade "A" Pasteurized Milk Ordinance, 2009 Revision, 398 pages.
 Hiroshi Ito: Coffee Exploration, Dec. 15, 1974, p. 226-231.
 Susumu Kimura: Dried Food Encyclopedia, Mar. 1, 1984, p. 162-163.
 AGA AB, "Reference Installation for cryo grinding of spices," Internal technical documentation, FOO-155-9111-1000-e and FOO-154-9111-2000-e, S-181 81 LIDINGO, Sweden (p. 19-20).
 KitchenAid, Pro Line Series, Guide to Professional Results, Model KPCG100 Burr Coffee Mill, (38 pages) 2003.
 Lin, "Cold Grinding of Food and Spices," Transfer Handbook, Section 7.2.3, pp. 19-20, Jun. 1992.
 Pallman, "The Role of Process Gas in Size Reduction Systems", Powder and Bulk Engineering International, Nov. 1999.
 Ritter, "Keep Cool with Cryogenic Grinding," Chemical Engineering, vol. 104, Issue 4, pp. 88-92, 1997.

* cited by examiner

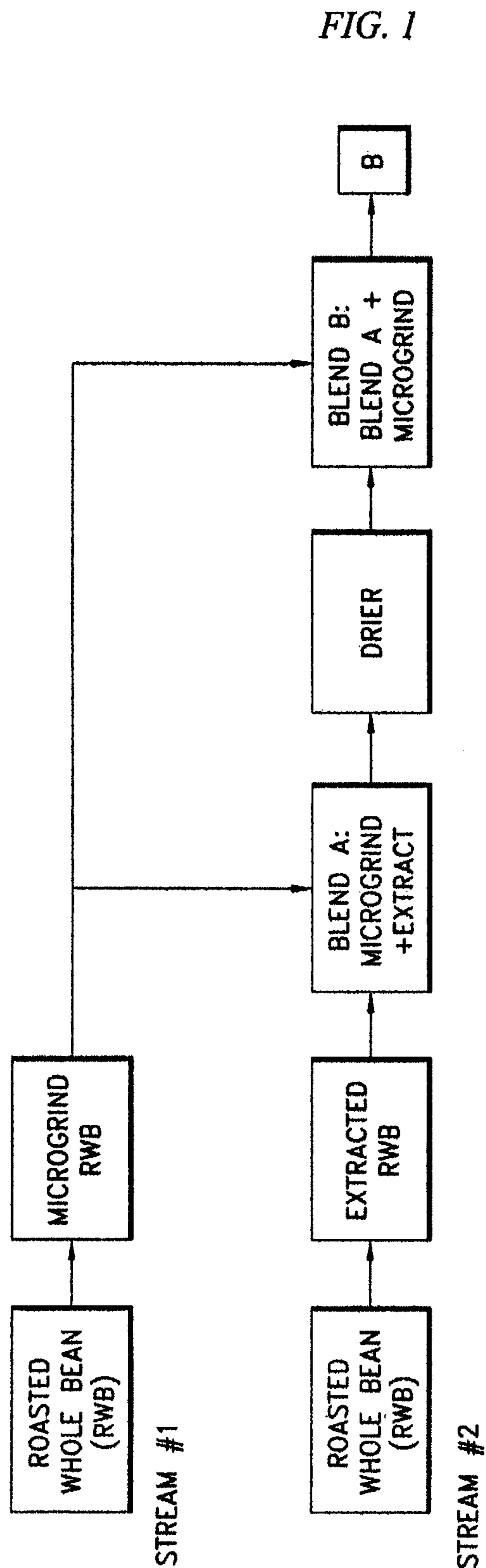

FIG. 1

FIG. 2

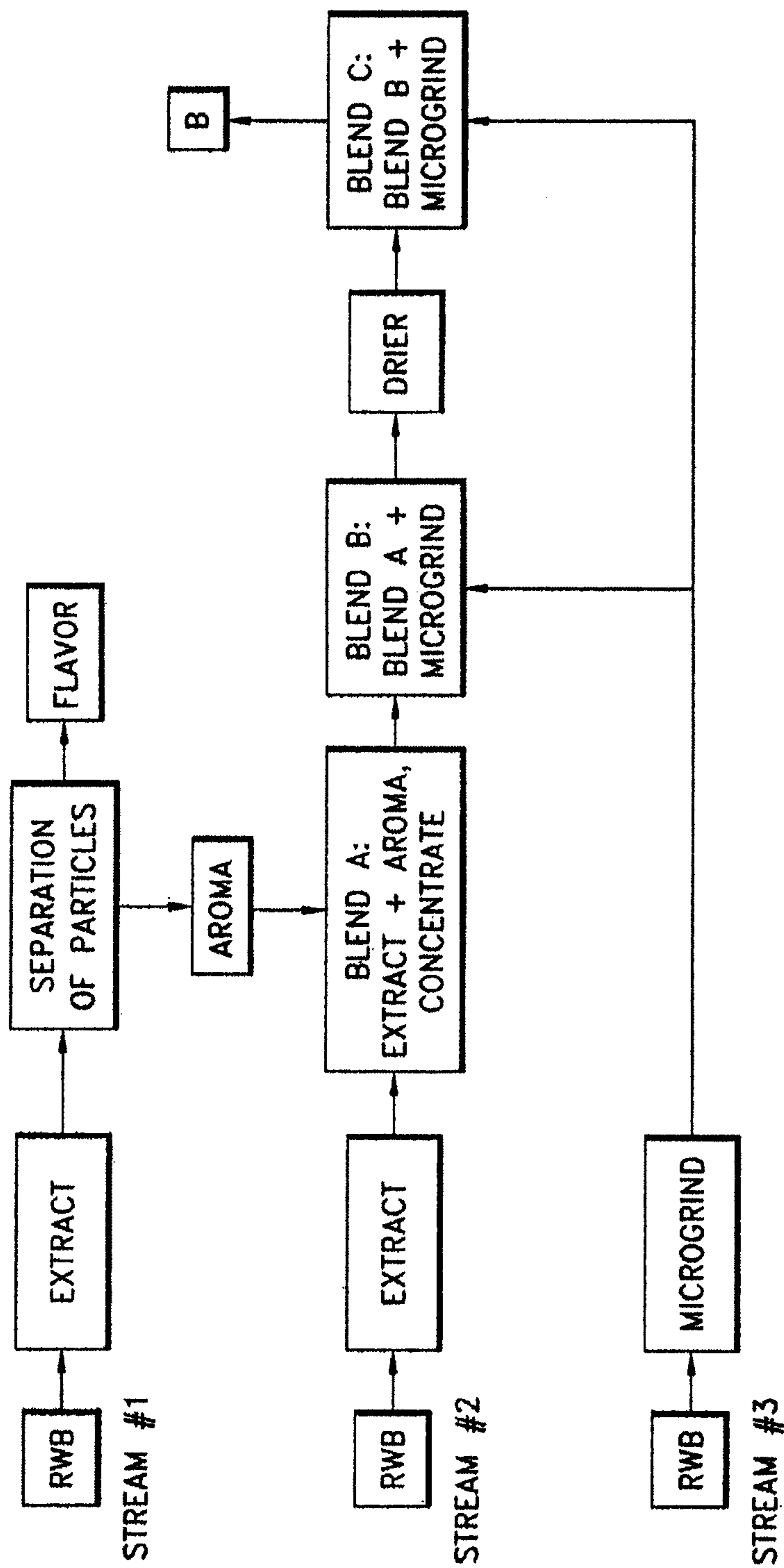
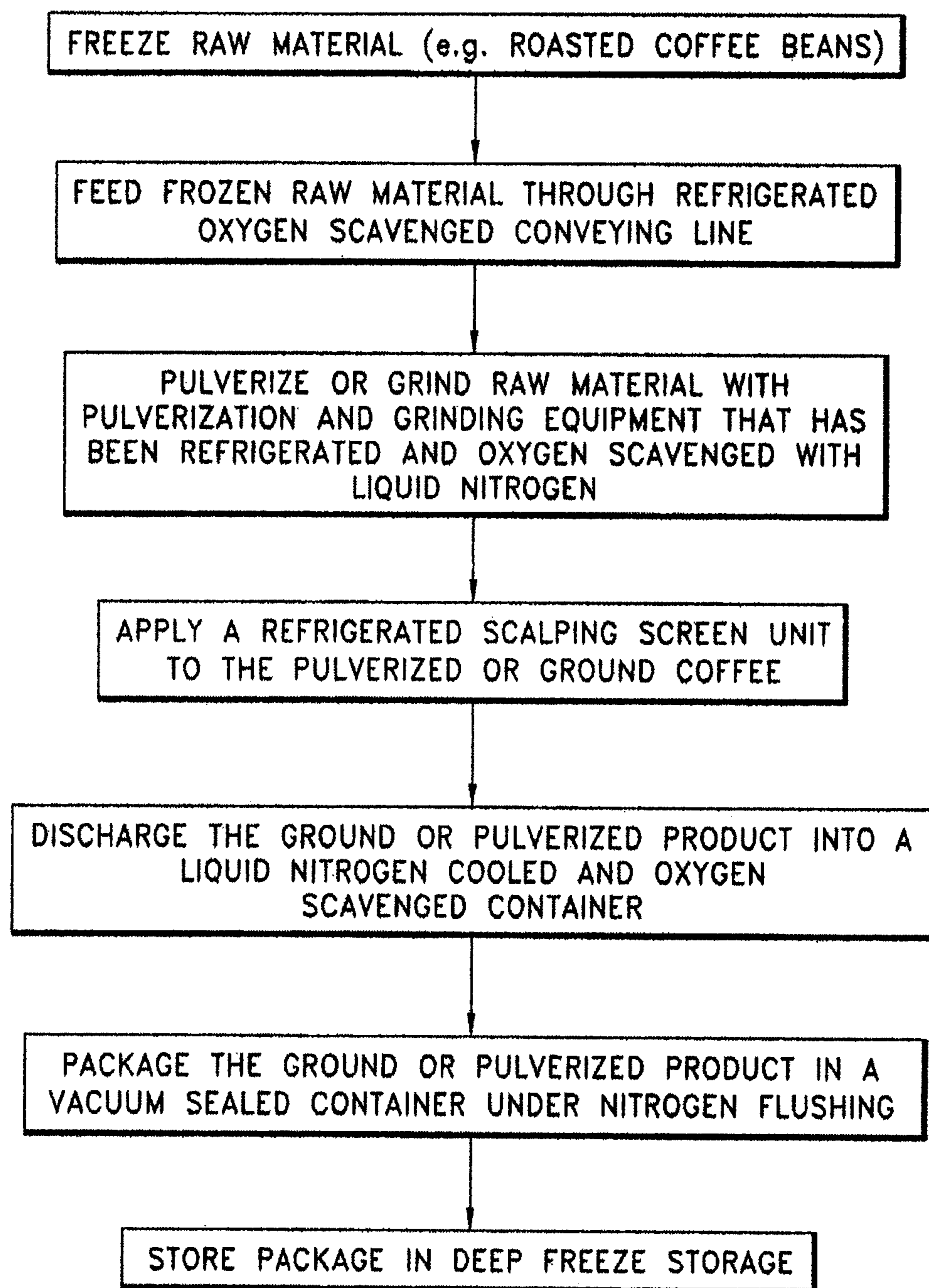

FIG. 2

FIG. 3



1

**SOLUBLE COFFEE PRODUCTS FOR
PRODUCING BEVERAGES WITH
ENHANCED FLAVORS AND AROMAS**

CROSS-REFERENCE TO RELATED
APPLICATIONS

This application is a continuation of and claims priority to U.S. patent application Ser. No. 13/207,962 filed Aug. 11, 2011, now U.S. Pat. No. 8,414,953, which is a divisional application of and claims priority to U.S. patent application Ser. No. 12/170,396 filed on Jul. 9, 2008, now U.S. Pat. No. 8,043,645, both of which are hereby incorporated in their entirety by reference.

BACKGROUND

Field

The present embodiments generally relate to beverages with enhanced qualities such as flavor and aroma and method of making same.

Description of the Related Art

Many beverages have a distinct taste and aroma that is difficult to duplicate in a more convenient form. One example of such a beverage is coffee. With regular coffee, water is boiled in a coffee pot in advance, and ground roasted coffee beans are put directly in contact with boiling water (the standard amount is 10 g of ground roasted coffee beans per 100 ml of boiling water) and are boiled in boiling water to effect extraction or are similarly extracted by using a percolator or the like. The obtained extract contains caffeine, tannic acid, saccharides, fats, proteins and various aromatic components and it has a fragrance inherent to coffee and a peculiar complicated flavor inclusive of a bitter taste, an astringent taste and an acid taste.

When roasted coffee beans are ground and then allowed to stand in air, they are readily oxidized which degrades the fragrance and flavors, and when tepid water is used for extraction, the contact time for extraction of roasted coffee beans is usually prolonged. Furthermore, if the boiling time is too long or the extract is allowed to stand for a long time, the fragrance and flavor are degraded. Accordingly, even in case of regular coffee, the method of making coffee is difficult, and it is very difficult to obtain coffee rich in flavor and fragrance.

Coffee extract concentrates and coffee extract powders have heretofore been manufactured on an industrial scale, and instant coffee beverages which can instantly be drunk by dissolving them in hot water or cold water have been prepared and marketed. Ordinarily, these instant coffee beverages are prepared according to a process comprising charging ground roasted coffee beans in an extraction tank, extracting the beans with hot water or boiling water, and subjecting the extract to drying treatments such as spray drying, vacuum drying or freeze drying. Instant coffee beverages prepared according to such conventional processes contain components which cannot ordinarily be drunk, though the amounts of these components differ to some extent according to the extraction conditions like the extraction temperature and time, the concentration conditions and the drying conditions.

Many aromas and flavors associated with coffee are very delicate and complex. With conventional soluble coffee, the delicate coffee flavors and aromas are often degraded or lost during processing and manufacturing methods. Coffee aroma is known to be very unstable. As coffee aroma degrades, it generates unpleasant and non-coffee-like notes

2

that are undesirable. This degradation substantially reduces the perceived quality of the product. For this reason, special attention must be paid to the preparation and storage of flavoring components such as coffee aroma so that desirable aroma components are enhanced or undesirable components are reduced or eliminated.

Furthermore, since the extract is exposed to high temperatures for a relatively long period of time during the preparation, the flavor and fragrance are degraded by cooking, evaporation and oxidative decomposition of aromatic components, and the delicate aroma inherent to coffee is lost. The conventional product usually comes to have an excessive scorching taste. In short, the obtained beverage is far from regular coffee in both the flavor and fragrance. The soluble coffee of the present embodiments overcome these problems in the prior art as well as provide additional advantages.

SUMMARY

Some embodiments relate to a soluble coffee product, comprising: a dry coffee extract component; and a pulverized coffee component, wherein the pulverized coffee component has not been extracted, and wherein the pulverized coffee component is added to the dry coffee extract component after the dry coffee extract is dried.

In some embodiments, the pulverized coffee component is added to the dry coffee extract component both before and after the dry coffee extract is dried.

In some embodiments, the dry coffee extract component comprises from about 70% to about 90% of the soluble coffee product and, wherein the ground coffee component comprises from about 10% to about 30% of the soluble coffee product.

In some embodiments, the dry coffee extract component comprises from about 70% to about 99.9% of the soluble coffee product and, wherein the ground coffee component comprises from about 0.1% to about 30% of the soluble coffee product.

In some embodiments, the pulverized coffee component has a mean particle size of about 350 microns or less. In some embodiments, the pulverized coffee component has a median particle size of about 350 microns or less.

Some embodiments further comprise an additive selected from the group consisting of coffee oils, non-coffee oils, non-coffee aromas, and coffee aromas.

Some embodiments further comprise at least one selected from the group consisting of coffee extract, concentrated coffee, dried coffee, coffee oils, coffee aromas (distillates), flavor powders, flavor oils, spices, ground or pulverized cocoa beans, ground or pulverized vanilla beans, vitamins, antioxidants, nutraceuticals, dietary fiber, an omega-3 oil, an omega-6 oil, an omega-9 oil, a flavonoid, lycopene, selenium, a beta-carotene, resveratrol, a vegetable extract, a dry green coffee extract, a wet green coffee extract and an herbal extract.

Some embodiments relate to a method of making a soluble coffee product, comprising: pulverizing coffee beans to form a first pulverized coffee product, grinding or pulverizing coffee beans to form a second ground or pulverized coffee product, extracting the second ground or pulverized coffee product to form an extracted coffee product, combining the first pulverized coffee product with the extracted coffee product to form a first coffee blend, drying the first coffee blend to form a first dried coffee blend, combining the first pulverized coffee product with the first dried coffee blend to form the soluble coffee product.

In some embodiments, the coffee is pre-frozen before being pulverized.

In some embodiments, the coffee is not pre-frozen before being pulverized, further comprising the step of refrigerating the grinding and pulverizing machinery.

In some embodiments, the coffee is pre-frozen, further comprising the step of refrigerating the grinding and pulverizing machinery.

Some embodiments further comprise the step of adding to the first coffee blend at least one selected from the group consisting of coffee extract, concentrated coffee, dried coffee, coffee oils, coffee aromas (distillates), flavor powders, flavor oils, spices, ground or pulverized cocoa beans, ground or pulverized vanilla beans, vitamins, antioxidants, nutraceuticals, dietary fiber, an omega-3 oil, an omega-6 oil, an omega-9 oil, a flavonoid, lycopene, selenium, a beta-carotene, resveratrol, a vegetable extract, dry green coffee extract, wet green coffee extract and an herbal extract.

In some embodiments, the grinding or pulverizing is carried out at a temperature of from about 20° C. to about 50° C.

Some embodiments further comprise the step of refrigerating grinding and pulverizing machinery to a temperature of about -5° C. or less.

Some embodiments relate to a method of making a soluble coffee product, comprising: grinding or pulverizing coffee beans to form a first ground or pulverized coffee product, grinding or pulverizing coffee beans to form a second ground or pulverized coffee product, pulverizing coffee beans to form a third pulverized coffee product, extracting the first ground or pulverized coffee product and separating the first ground or pulverized coffee product into a coffee flavor component and a coffee aroma component, extracting the second ground or pulverized coffee product to form a first extracted coffee product, combining the coffee aroma component with the extracted coffee product to form a first coffee blend, combining the first coffee blend with the third pulverized coffee product to form a second coffee blend, drying the second coffee blend to form a first dried coffee blend, combining the third pulverized coffee with the first dried coffee blend to form the soluble coffee.

In some embodiments, the coffee is pre-frozen before the pulverizing.

In some embodiments, the coffee is not pre-frozen before the pulverizing, further comprising the step of refrigerating the grinding and pulverizing machinery.

Some embodiments further comprise the step of adding to the first coffee blend at least one selected from the group consisting of coffee extract, concentrated coffee, dried coffee, coffee oils, coffee aromas (distillates), flavor powders, flavor oils, spices, ground or pulverized cocoa beans, ground or pulverized vanilla beans, vitamins, antioxidants, nutraceuticals, dietary fiber, an omega-3 oil, an omega-6 oil, an omega-9 oil, a flavonoid, lycopene, selenium, a beta-carotene, resveratrol, a vegetable extract, dry green coffee extract, wet green coffee extract and an herbal extract.

In some embodiments, the pulverizing and grinding is carried out at a temperature of from about 20° C. to about 50° C.

In some embodiments, the pulverizing and grinding is carried out at a temperature of less than about 1° C.

In some embodiments, the temperature of the equipment and coffee product in each step is about -5° C. or less.

Some embodiments relate to a soluble coffee product prepared by a method comprising: pulverizing coffee beans to form a first pulverized coffee product grinding or pulverizing coffee beans to form a second ground or pulverized

coffee product, extracting the second ground or pulverized coffee product to form an extracted coffee product, combining the first pulverized coffee product with the extracted coffee product to form a first coffee blend, drying the first coffee blend to form a first dried coffee blend, combining the first pulverized coffee product with the first dried coffee blend to form the soluble coffee product.

In some embodiments, the dry coffee extract component comprises from about 70% to about 90% of the soluble coffee product and, wherein the ground coffee component comprises from about 10% to about 30% of the soluble coffee product.

In some embodiments, the dry coffee extract component comprises from about 70% to about 99.9% of the soluble coffee product and, wherein the ground coffee component comprises from about 0.1% to about 30% of the soluble coffee product.

In some embodiments, the ground coffee component has a mean particle size of about 350 microns or less. In some embodiments, the pulverized coffee component has a median particle size of about 350 microns or less.

Some embodiments further comprise at least one selected from the group consisting of coffee oils, non-coffee oils, non-coffee aromas, and coffee aromas.

Some embodiments further comprise at least one additive selected from the group consisting of coffee extract, concentrated coffee, dried coffee, coffee oils, coffee aromas (distillates), flavor powders, flavor oils, spices, ground or pulverized cocoa beans, ground or pulverized vanilla beans, vitamins, antioxidants, nutraceuticals, dietary fiber, an omega-3 oil, an omega-6 oil, an omega-9 oil, a flavonoid, lycopene, selenium, a beta-carotene, resveratrol, a vegetable extract, dry green coffee extract, wet green coffee extract and an herbal extract.

Some embodiments relate to a method of making a soluble coffee product, comprising: grinding or pulverizing coffee beans to form a first ground or pulverized coffee product, grinding or pulverizing coffee beans to form a second ground or pulverized coffee product, pulverizing coffee beans to form a third pulverized coffee product, extracting the first ground or pulverized coffee product and separating the first ground or pulverized coffee product into at least a first extracted component and a extracted second component, extracting the second ground or pulverized coffee product to form a first extracted coffee product, combining the coffee aroma component with the extracted coffee product to form a first coffee blend, combining the first coffee blend with the third pulverized coffee product to form a second coffee blend, drying the second coffee blend to form a first dried coffee blend, combining the third pulverized coffee with the first dried coffee blend to form the soluble coffee.

In some embodiments, the first extracted component is a flavor component and the second extracted component is an aroma component.

In some embodiments, the coffee is pre-frozen before the pulverizing.

In some embodiments, the coffee is not pre-frozen before the pulverizing, further comprising the step of refrigerating the grinding and pulverizing machinery.

Some embodiments further comprise the step of adding to the first coffee blend at least one selected from the group consisting of coffee extract, concentrated coffee, dried coffee, coffee oils, coffee aromas (distillates), flavor powders, flavor oils, spices, ground or pulverized cocoa beans, ground or pulverized vanilla beans, vitamins, antioxidants, nutraceuticals, dietary fiber, an omega-3 oil, an omega-6 oil, an

5

omega-9 oil, a flavonoid, lycopene, selenium, a beta-carotene, resveratrol, a vegetable extract, dry green coffee extract, wet green coffee extract and an herbal extract.

In some embodiments, the pulverizing and grinding is carried out at a temperature of from about 20° C. to about 50° C.

In some embodiments, the pulverizing and grinding is carried out at a temperature of less than about 1° C.

In some embodiments, the temperature of the equipment and coffee product in each step is about -5° C. or less.

Some embodiments further comprise the step of adding the first extracted component or the second extracted component to the first dried coffee blend.

BRIEF DESCRIPTION OF THE DRAWINGS

FIG. 1 is a process flow diagram illustrating an overview of one embodiment of a method of making a coffee beverage with enhanced flavor and aroma.

FIG. 2 is a process flow diagram illustrating an overview of one embodiment of a method making a coffee beverage with enhanced flavor and aroma.

FIG. 3 is a process flow diagram illustrating an overview of one embodiment of a method of pulverizing a raw material in a refrigerated environment.

DETAILED DESCRIPTION

The following discussion is presented to enable a person skilled in the art to make and use one or more of the present embodiments. The general principles described herein may be applied to embodiments and applications other than those detailed below without departing from the spirit and scope of the disclosure. Therefore the present embodiments are not intended to be limited to the particular embodiments shown, but are to be accorded the widest scope consistent with the principles and features disclosed or suggested herein.

Coffee and other products subjected to processing such as that necessary to make an instant form of the product go through flavor and aroma changes. These changes come from the altering of the initial bonded structures of the compounds within the products. With coffee, any kind of processing can alter the bonded structures of the compounds found in unprocessed coffee beans. Some embodiments relate to a method of adding or restoring the flavor and aroma associated with an unprocessed food product to a processed or instant version of the product. In some embodiments, the product is coffee. Some embodiments relate to methods involving pulverization of, for example, roasted coffee beans, fresh tea leaves, coco beans or other food ingredients as a mean of adding or restoring freshness, flavor and aroma of, for example, soluble coffee, teas, chocolates, etc. Some embodiments also allow for the introduction of different and unique flavors and aromas into food products. Some embodiments allow for the introduction of supplements to food products.

Some embodiments of the present disclosure are directed to soluble coffee and methods of making soluble coffee with improved taste and aroma. Referring to FIG. 1, in accordance with an illustrative embodiment, two streams of roasted whole coffee beans are prepared and treated. In the first stream, roasted whole bean coffee beans are pulverized to form pulverized coffee. In some embodiments, the pulverized coffee has a particle size of less than about 350 microns in diameter. In some embodiments, the pulverized coffee component has a median particle size of about 350 microns or less. In the second stream, roasted whole bean

6

coffee beans are ground or pulverized and extracted to produce a wet coffee extract. A portion of the pulverized coffee from the first stream is added to the wet coffee extract of the second stream to form Blend A.

In the embodiments described in FIG. 1, the combination of pulverized roasted whole bean coffee beans from the first stream with the extracted ground or pulverized whole bean coffee of the second stream at this wet stage of the process adds complexity, including a more authentic coffee flavor and aroma, to the soluble coffee. Blend A is then dried in a drying process (e.g., freeze-dried, hot air dried, or any other drying process). Dried blend A is then combined with at least one additional component to form blend B, which, in this embodiment, is the bulk soluble coffee product. Such components can include, for example, pulverized coffee from the first stream, coffee extract, concentrated coffee, dried coffee, coffee oils, coffee aromas, distillates, flavor powders, flavor oils, spices, ground or pulverized cocoa beans, ground or pulverized vanilla beans, vitamins, antioxidants, nutraceuticals, dietary fiber, an omega-3 oil, an omega-6 oil, an omega-9 oil, a flavonoid, lycopene, selenium, a beta-carotene, resveratrol, a vegetable extract and an herbal extract etc. In certain embodiments the dried blend A is combined with pulverized coffee from the first stream to form blend B.

In some embodiments, the dry addition of pulverized coffee to dry coffee extract adds aroma, flavor complexity and body to the finished bulk product. The addition of pulverized coffee can be accomplished by one or more of many different methods, e.g., centrifugal equipment, lightning mixer, ribbon blender, PK blender, sonic methods, etc. In some embodiments, other compounds may be added during the process, including non-coffee oils, non-coffee aromas, coffee aromas, etc. In some embodiments, pulverized coffee can be encapsulated with carbohydrates, soy products, dairy ingredients or other agents. One advantage of the encapsulation is to protect against degradation from environmental factors.

Coffee aromas are the volatile components of coffee that produce the characteristic fragrance of coffee. In some embodiments, the coffee aroma can be provided to the final beverage product in the form of a highly aromatized coffee concentrate. The aromatized coffee concentrate is prepared by adding coffee aroma to a coffee concentrate. Methods of preparing coffee concentrates are well known to one of skill in the art.

In some embodiments, coffee aroma is in the form of natural coffee aroma components that are collected during the preparation of soluble coffee powder. In some embodiments, the natural coffee aroma includes highly volatile aroma components. Highly volatile aroma components are those which condense at a temperature below about 0° C. To recover highly volatile aroma components, volatile aroma components may be flushed from the coffee during processing using an inert carrier gas such as nitrogen. The aromaladen carrier gas is then chilled to temperatures lower than about -40° C., and sometimes as low as about -195° C., to cause the aroma components to condense. The condensed aroma components are then collected. Suitable procedures for capturing coffee aroma are known to one of skill in the art.

Referring to FIG. 2, in accordance with an illustrative embodiment, three streams of roasted whole coffee beans are treated to form a coffee product with enhanced flavor and aroma components. In the first stream, roasted whole bean coffee beans are pulverized or ground to form pulverized or ground coffee. In some embodiments, the pulverized or ground coffee has a particle size of less than about 350

microns in diameter. In some embodiments, the pulverized coffee component has a median particle size of about 350 microns or less in diameter. The pulverized or ground coffee is then extracted to separate the aroma compounds from the flavor compounds. In the second stream, roasted whole bean coffee beans are pulverized or ground and extracted to produce a wet coffee extract. A portion of the separated aroma components from the first stream is added to the wet coffee extract of the second stream to form Blend A. In the third stream, roasted whole bean coffee beans are pulverized and a portion of the resulting pulverized coffee is added to wet blend A to form blend B.

Blend B is then dried in a drying process (e.g., freeze-dried, or any other drying process). Dried Blend B is then combined with at least one of: pulverized coffee from the third stream, coffee extract, concentrated coffee, dried coffee, coffee oils, coffee aromas (distillates), flavor powders, flavor oils, spices, ground or pulverized cocoa beans, ground or pulverized vanilla beans, vitamins, antioxidants, nutraceuticals, dietary fiber, an omega-3 oil, an omega-6 oil, an omega-9 oil, a flavonoid, lycopene, selenium, a beta-carotene, resveratrol, a vegetable extract and an herbal extract to form Blend C, which, in this embodiment, is the bulk soluble coffee product. In certain embodiments the dried Blend B is combined with pulverized coffee from the third stream to form Blend C. In some embodiments, the flavor components of the extracted pulverized or ground coffee of the first stream are combined with blend A. In some embodiments, the flavor components of the extracted pulverized or ground coffee of the first stream are combined with blend B. In some embodiments, the flavor components of the extracted pulverized or ground coffee of the first stream are combined with blend C.

In some embodiments, the combination of the pulverized or ground roasted whole bean coffee aroma separation components from the first stream with the extracted pulverized or ground whole bean coffee of the second stream at this wet stage of the process adds a unique aroma property, including a more authentic coffee aroma, to the soluble coffee.

FIG. 3 depicts an illustrative process for preparing some of the products of certain embodiments. In this example, roasted coffee beans are frozen at a temperature below about -5° C. and then fed through a conveying line that is also refrigerated. Then the product is pulverized in the presence of liquid nitrogen and sent through a scalping screen to ensure the passage of only small particle pulverization product. In some embodiments, liquid nitrogen is added directly to the product. In some embodiments, the liquid nitrogen is used to cool the grinding or pulverizing machinery. In some embodiments the liquid nitrogen is added directly to the product and also used to cool the grinding or pulverizing machinery. In an illustrative embodiment, the ground product is then discharged into packaging, vacuum sealed, flushed with nitrogen and then stored in deep freeze storage. However, in some embodiments, the ground product is instead introduced into other process steps as those discussed herein. In some embodiments, the packaged and stored product can be later used in other processes as well.

In some embodiments, the pulverized or ground coffee can be produced in concert with refrigeration of the grinding machinery. Also, in some embodiments, ground or pulverized coffee product can be cooled as it leaves the grinding machinery. In some embodiments the grinding machinery is refrigerated and also the pulverized or ground coffee product is cooled as it exits the grinding machinery.

In accordance with some embodiments, coffee can be processed as described above to maintain a pleasing flavor and aroma. In some embodiments, roasted whole bean coffee is processed under low temperatures, for example, less than about 15° C. and low relative humidity, for example, less than about 30%. In some embodiments, the internal temperature of the milling equipment is controlled to ensure a temperature of less than about 15° C. Roasted whole bean coffee beans can be pre-frozen and surfaces that come into contact with the coffee beans can be kept cooled with a cooling medium, such as, for example, liquid nitrogen, to avoid flavor loss and degradation.

Coffee exposure to oxygen can be minimized using conventional methods, for example, nitrogen purging, vacuum packaging, etc. Also, liquid nitrogen can be used as an oxygen scavenger during processing to minimize the degradative effects of oxygen. Coffee that is pulverized under such conditions retains much of its original flavor and aroma. Such pulverized coffee can be blended or encapsulated with coffee in various forms, including ground coffee, extracts, concentrate coffee, dried coffee, coffee oils, aromas (distillates), carbohydrates, soy products, dairy products or other agents and subsequently added to dry soluble coffee.

In some embodiments, coffee and other products being subjected to pulverization are deep frozen (colder than -5° C.) prior to grinding. This process allows for better pulverization of the product and yields more homogenous particles while minimizing the oxidation and degradation of the pulverized product. Lines supplying the grinder can be equipped with, for example, refrigerants or a liquid nitrogen feeding system in order to maintain the low temperature and efficiency. Cooling and scavenging gases are ideal, since they can provide cooling and removal of oxidizing elements. To minimize condensation, the equipment can be insulated to avoid surface and internal condensations in the conveying equipment, pulverizing equipment and collection/storage equipment of the milled product.

Any type of grinding equipment can be used in the present embodiments, for example, a cage mill, a hammer mill, etc. to pulverize a product such as coffee. In some embodiments, the equipment is maintained at very low temperatures (20° C. to -50° C.) via cooling media. This helps maintain the integrity of the material being pulverized. Liquid nitrogen or other refrigerants can be used to cool the equipment. Pulverization generates heat, which combined with exposed oxygen, can often degrade the pulverized product. Feeding liquid nitrogen to the grinding cavity is one example of a way to keep the grinding machine at low temperatures as well as displacing and scavenging oxygen.

In some embodiments the pulverized product falls into a refrigerated container at from about 0° C. to about 20° C. In some embodiments the pulverized product falls into a refrigerated container at less than about 20° C. Some embodiments involve using liquid nitrogen cooling of the container including liquid or gas nitrogen inside the container for product preservation. During operation, the discharging cavity should be continually flushed with gaseous nitrogen to minimize oxidation. In some embodiments, the operation takes place under controlled environmental conditions to protect the resulting product from moisture uptake.

In some embodiments, in order to ensure quality, the final product is moved to an oxygen free environment, vacuum packed, sealed and stored under deep freeze conditions (about -20° C. or colder), until used or sold.

Some embodiments relate to blending pulverized components in with liquid (wet blending) and dry (dry blending) coffee ingredients and/or related products. The dry or wet

blending operation is the process of incorporating, adding, infusing, mixing, encapsulating, spraying or fluidizing, etc, the pulverized product into a coffee or appropriate product stream at required ratio to deliver design aroma, flavor, and appearance. Adequate processing (ribbon blender, PK blenders, fluidizing beds, coaters or others) and mixing equipments can be used to ensure homogeneity. In some embodiments the wet blending takes place at controlled temperatures, e.g., less than about 15° C. Rotation, cycle time and control of the process can differ, however, in some embodiments, these variables are controlled in such a way as to ensure uniform distribution, and prevent foaming and particle segregation.

In some embodiments, dry blending occurs in an enclosed blender and a controlled environment to minimize oxidation and moisture exposure. Upon blending, the product can be readily stored in proper packaging, such as, for example packed tightly to form a brick like package with nitrogen flushing and maintained under controlled conditions, such as temperatures less than about 10° C.

In some embodiments, the physicochemical and sensory attributes of pulverized products can also be protected by means of encapsulation (spray-drying, coating, extrusion, coacervation and molecular inclusion). Some embodiments utilize microencapsulation. With encapsulation, the encasing layer is attained, for example, via molecular, interfacial, colloidal and bulk physicochemical properties of emulsions. The encasement reduces the reactivity of the core with regard to outside environment, for example oxygen and water. This permits the extension of shelf life of a product in conventional packaging applications. In some embodiments, encapsulation can be used for controlled release of the inner material or core. The encased pulverized product can remain inactive until direct contact with water. Then the water can dissolve the encasement and the pulverized product is able to react with water, releasing aromas and flavors.

In some embodiments, the encapsulation of pulverized coffee can be used to optimize product functionality, particle size and/or create a new product form. Encapsulation can be done with products including, coffee extracts, coffee concentrates, dry pulverized coffee, coffee oils or other oils, aromas, functional ingredients, etc. In addition, pulverized products can be encapsulated by carbohydrates, soy products, dairy products or other agents to protect against environmental elements

Conditional language, such as, among others, “can,” “could,” “might,” or “may,” unless specifically stated otherwise, or otherwise understood within the context as used, is generally intended to convey that certain embodiments include, while other embodiments do not include, certain features, elements and/or steps. Thus, such conditional language is not generally intended to imply that features, elements and/or steps are in any way required for one or more embodiments or that one or more embodiments necessarily include logic for deciding, with or without user input or prompting, whether these features, elements and/or steps are included or are to be performed in any particular embodiment.

It should be emphasized that many variations and modifications may be made to the above-described embodiments, the elements of which are to be understood as being among other acceptable examples. All such modifications and variations are intended to be included herein within the scope of this disclosure and protected by the following claims.

What is claimed is:

1. A soluble coffee product, comprising:
a dry coffee extract component; and

a pulverized coffee component,
wherein the pulverized coffee component has not been extracted, and

wherein the pulverized coffee component is added to the dry coffee extract component before and after the dry coffee extract component is dried.

2. The soluble coffee product of claim 1, wherein the dry coffee extract component comprises from about 70% to about 90% of the soluble coffee product and, wherein the pulverized coffee component comprises from about 10% to about 30% of the soluble coffee product.

3. The soluble coffee product of claim 1, wherein the dry coffee extract component comprises from about 70% to about 99.9% of the soluble coffee product and, wherein the pulverized coffee component comprises from about 0.1% to about 30% of the soluble coffee product.

4. The soluble coffee product of claim 1, wherein the pulverized coffee component has a mean particle size of about 350 microns or less.

5. The soluble coffee product of claim 1, wherein the pulverized coffee component has a median particle size of about 350 microns or less.

6. The soluble coffee product of claim 1, further comprising an additive selected from the group consisting of coffee oils, non-coffee oils, non-coffee aromas, and coffee aromas.

7. The soluble coffee product of claim 1, further comprising at least one selected from the group consisting of coffee components, nutritional supplements, flavoring components and herbal components.

8. The soluble coffee product of claim 1, further comprising at least one selected from the group consisting of coffee extract, concentrated coffee, dried coffee, coffee oils, coffee aromas, distillates, flavor powders, flavor oils, spices, ground or pulverized cocoa beans, ground or pulverized vanilla beans, vitamins, antioxidants, nutraceuticals, dietary fiber, an omega-3 oil, an omega-6 oil, an omega-9 oil, a flavonoid, lycopene, selenium, a beta-carotene, resveratrol, a vegetable extract, a dry green coffee extract, a wet green coffee extract and an herbal extract.

9. A soluble coffee product, comprising:

a dry coffee extract component; and

a pulverized coffee component having a mean particle size of about 350 microns or less,

wherein the pulverized coffee component has not been extracted, and

wherein the pulverized coffee component is added to the dry coffee extract component after the dry coffee extract component is dried.

10. The soluble coffee product of claim 9, wherein the pulverized coffee component is added to the dry coffee extract component both before and after the dry coffee extract component is dried.

11. The soluble coffee product of claim 9, wherein the dry coffee extract component comprises from about 70% to about 90% of the soluble coffee product and, wherein the pulverized coffee component comprises from about 10% to about 30% of the soluble coffee product.

12. The soluble coffee product of claim 9, wherein the dry coffee extract component comprises from about 70% to about 99.9% of the soluble coffee product and, wherein the pulverized coffee component comprises from about 0.1% to about 30% of the soluble coffee product.

13. The soluble coffee product of claim 9, wherein the pulverized coffee component has a mean particle size of about 250 microns or less.

11

14. The soluble coffee product of claim 9, wherein the pulverized coffee component has a median particle size of about 350 microns or less.

15. The soluble coffee product of claim 9, further comprising an additive selected from the group consisting of coffee oils, non-coffee oils, non-coffee aromas, and coffee aromas.

16. The soluble coffee product of claim 9, further comprising at least one selected from the group consisting of coffee components, nutritional supplements, flavoring components and herbal components.

17. The soluble coffee product of claim 9, further comprising at least one selected from the group consisting of coffee extract, concentrated coffee, dried coffee, coffee oils, coffee aromas, distillates, flavor powders, flavor oils, spices, ground or pulverized cocoa beans, ground or pulverized vanilla beans, vitamins, antioxidants, nutraceuticals, dietary fiber, an omega-3 oil, an omega-6 oil, an omega-9 oil, a flavonoid, lycopene, selenium, a beta-carotene, resveratrol, a vegetable extract, a dry green coffee extract, a wet green coffee extract and an herbal extract.

18. A soluble coffee product, comprising:

a dry coffee extract component;

a coffee aroma component; and

a pulverized coffee component with a mean or median particle size of about 350 microns or less,

wherein the pulverized coffee component has not been extracted, and

wherein the pulverized coffee component is added to the dry coffee extract component after the dry coffee component extract is dried.

19. The soluble coffee product of claim 18, wherein the pulverized coffee component is added to the dry coffee extract component both before and after the dry coffee extract component is dried.

20. The soluble coffee product of claim 18, wherein the dry coffee extract component comprises from about 70% to about 90% of the soluble coffee product and, wherein the pulverized coffee component comprises from about 10% to about 30% of the soluble coffee product.

21. The soluble coffee product of claim 18, wherein the dry coffee extract component comprises from about 70% to about 99.9% of the soluble coffee product and, wherein the pulverized coffee component comprises from about 0.1% to about 30% of the soluble coffee product.

22. The soluble coffee product of claim 18, further comprising an additive selected from the group consisting of coffee oils, non-coffee oils, non-coffee aromas, and coffee aromas.

23. The soluble coffee product of claim 18, further comprising at least one selected from the group consisting of coffee components, nutritional supplements, flavoring components and herbal components.

24. The soluble coffee product of claim 18, further comprising at least one selected from the group consisting of coffee extract, concentrated coffee, dried coffee, coffee oils, coffee aromas, distillates, flavor powders, flavor oils, spices, ground or pulverized cocoa beans, ground or pulverized vanilla beans, vitamins, antioxidants, nutraceuticals, dietary fiber, an omega-3 oil, an omega-6 oil, an omega-9 oil, a flavonoid, lycopene, selenium, a beta-carotene, resveratrol, a vegetable extract, a dry green coffee extract, a wet green coffee extract and an herbal extract.

25. A soluble coffee product, comprising:

a dry coffee extract component obtained from ground coffee; and

12

a pulverized coffee component with a mean or median particle size of about 350 microns or less, wherein the pulverized coffee component has not been extracted, and

wherein the pulverized coffee component is added to the dry coffee extract component after the dry coffee extract component is dried.

26. The soluble coffee product of claim 25, wherein the pulverized coffee component is added to the dry coffee extract component both before and after the dry coffee extract component is dried.

27. The soluble coffee product of claim 25, wherein the dry coffee extract component comprises from about 70% to about 90% of the soluble coffee product and, wherein the pulverized coffee component comprises from about 10% to about 30% of the soluble coffee product.

28. The soluble coffee product of claim 25, wherein the dry coffee extract component comprises from about 70% to about 99.9% of the soluble coffee product and, wherein the pulverized coffee component comprises from about 0.1% to about 30% of the soluble coffee product.

29. The soluble coffee product of claim 25, further comprising an additive selected from the group consisting of coffee oils, non-coffee oils, non-coffee aromas, and coffee aromas.

30. The soluble coffee product of claim 25, further comprising at least one selected from the group consisting of coffee components, nutritional supplements, flavoring components and herbal components.

31. The soluble coffee product of claim 25, further comprising at least one selected from the group consisting of coffee extract, concentrated coffee, dried coffee, coffee oils, coffee aromas, distillates, flavor powders, flavor oils, spices, ground or pulverized cocoa beans, ground or pulverized vanilla beans, vitamins, antioxidants, nutraceuticals, dietary fiber, an omega-3 oil, an omega-6 oil, an omega-9 oil, a flavonoid, lycopene, selenium, a beta-carotene, resveratrol, a vegetable extract, a dry green coffee extract, a wet green coffee extract and an herbal extract.

32. A soluble coffee product, comprising:

a dry coffee extract component; and

a non-extracted coffee component having a mean or median particle size of about 350 microns or less and pulverized in a low oxygen environment,

wherein the non-extracted coffee component is added to the dry coffee extract component after the dry coffee extract component is dried.

33. The soluble coffee product of claim 32, wherein the non-extracted coffee component is added to the dry coffee extract component both before and after the dry coffee extract is dried.

34. The soluble coffee product of claim 32, wherein the dry coffee extract component comprises from about 70% to about 90% of the soluble coffee product and, wherein the non-extracted coffee component comprises from about 10% to about 30% of the soluble coffee product.

35. The soluble coffee product of claim 32, wherein the dry coffee extract component comprises from about 70% to about 99.9% of the soluble coffee product and, wherein the non-extracted coffee component comprises from about 0.1% to about 30% of the soluble coffee product.

36. The soluble coffee product of claim 32, further comprising an additive selected from the group consisting of coffee oils, non-coffee oils, non-coffee aromas, and coffee aromas.

37. The soluble coffee product of claim 32, further comprising at least one selected from the group consisting of

coffee components, nutritional supplements, flavoring components and herbal components.

38. The soluble coffee product of claim **32**, further comprising at least one selected from the group consisting of coffee extract, concentrated coffee, dried coffee, coffee oils, 5 coffee aromas, distillates, flavor powders, flavor oils, spices, ground or pulverized cocoa beans, ground or pulverized vanilla beans, vitamins, antioxidants, nutraceuticals, dietary fiber, an omega-3 oil, an omega-6 oil, an omega-9 oil, a flavonoid, lycopene, selenium, a beta-carotene, resveratrol, 10 a vegetable extract, a dry green coffee extract, a wet green coffee extract and an herbal extract.

* * * * *