

US010149928B2

(12) **United States Patent**  
**Locke et al.**

(10) **Patent No.:** **US 10,149,928 B2**  
(45) **Date of Patent:** **\*Dec. 11, 2018**

(54) **ADJUSTABLE REDUCED-PRESSURE WOUND COVERINGS**

(71) Applicant: **KCI Licensing, Inc.**, San Antonio, TX (US)

(72) Inventors: **Christopher Brian Locke**, Bournemouth (GB); **Timothy Mark Robinson**, Basingstoke (GB); **Richard Daniel John Coulthard**, Verwood (GB)

(73) Assignee: **KCI Licensing, Inc.**, San Antonio, TX (US)

(\*) Notice: Subject to any disclaimer, the term of this patent is extended or adjusted under 35 U.S.C. 154(b) by 566 days.  
This patent is subject to a terminal disclaimer.

(21) Appl. No.: **14/832,770**

(22) Filed: **Aug. 21, 2015**

(65) **Prior Publication Data**

US 2016/0000608 A1 Jan. 7, 2016

**Related U.S. Application Data**

(60) Continuation of application No. 13/875,085, filed on May 1, 2013, now Pat. No. 9,254,353, which is a (Continued)

(51) **Int. Cl.**  
*A61M 1/00* (2006.01)  
*A61F 13/00* (2006.01)

(52) **U.S. Cl.**  
CPC ..... *A61M 1/0023* (2013.01); *A61F 13/00029* (2013.01); *A61F 13/00034* (2013.01); (Continued)

(58) **Field of Classification Search**  
CPC ..... A61B 17/32; A61B 17/3205; A61B 42/00; A61B 46/20; A61B 42/40; A61F 13/00017

See application file for complete search history.

(56) **References Cited**

U.S. PATENT DOCUMENTS

1,355,846 A 10/1920 Rannells  
2,547,758 A 4/1951 Kelling  
(Continued)

FOREIGN PATENT DOCUMENTS

AU 550575 B2 3/1986  
AU 745271 B2 3/2002  
(Continued)

OTHER PUBLICATIONS

Louis C. Argenta, MD and Michael J. Morykwas, PHD; Vacuum-Assisted Closure: A New Method for Wound Control and Treatment: Clinical Experience; Annals of Plastic Surgery.  
(Continued)

*Primary Examiner* — Tatyana Zalukaeva  
*Assistant Examiner* — Gabriella Burnette

(57) **ABSTRACT**

Adjustable covers, systems, and methods are presented that include an adjustable cover that may be adjusted to an appropriate size by hand without requiring cutting tools and without substantial leaks. In one instance, the adjustable covering includes a drape member with a plurality of non-leaking tear paths. Each non-leaking tear path includes a weakened path of the drape member that may be torn. The adjustable covering may further include a first plurality of tear starters formed on a first initiation edge of the drape member. Each tear starter of the first plurality of tear starters is aligned with one of the plurality of tear paths. Each of the first plurality of tear starters is adapted to facilitate the initiation of a tear along a tear path. The grains of the drape member, a backing layer, and support layer may also be in the same direction. Other adjustable covers, systems, and methods are presented.

**16 Claims, 4 Drawing Sheets**

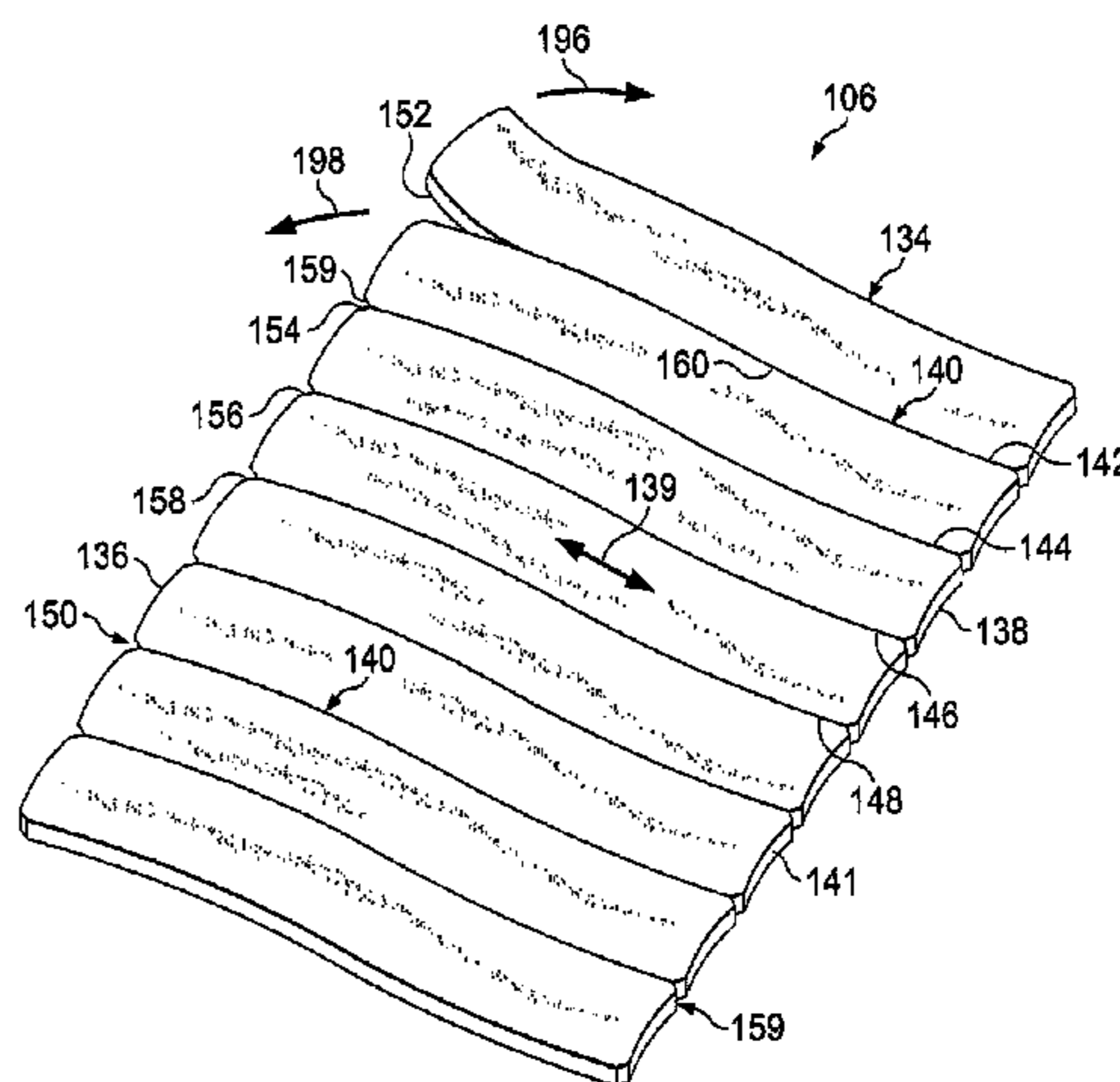
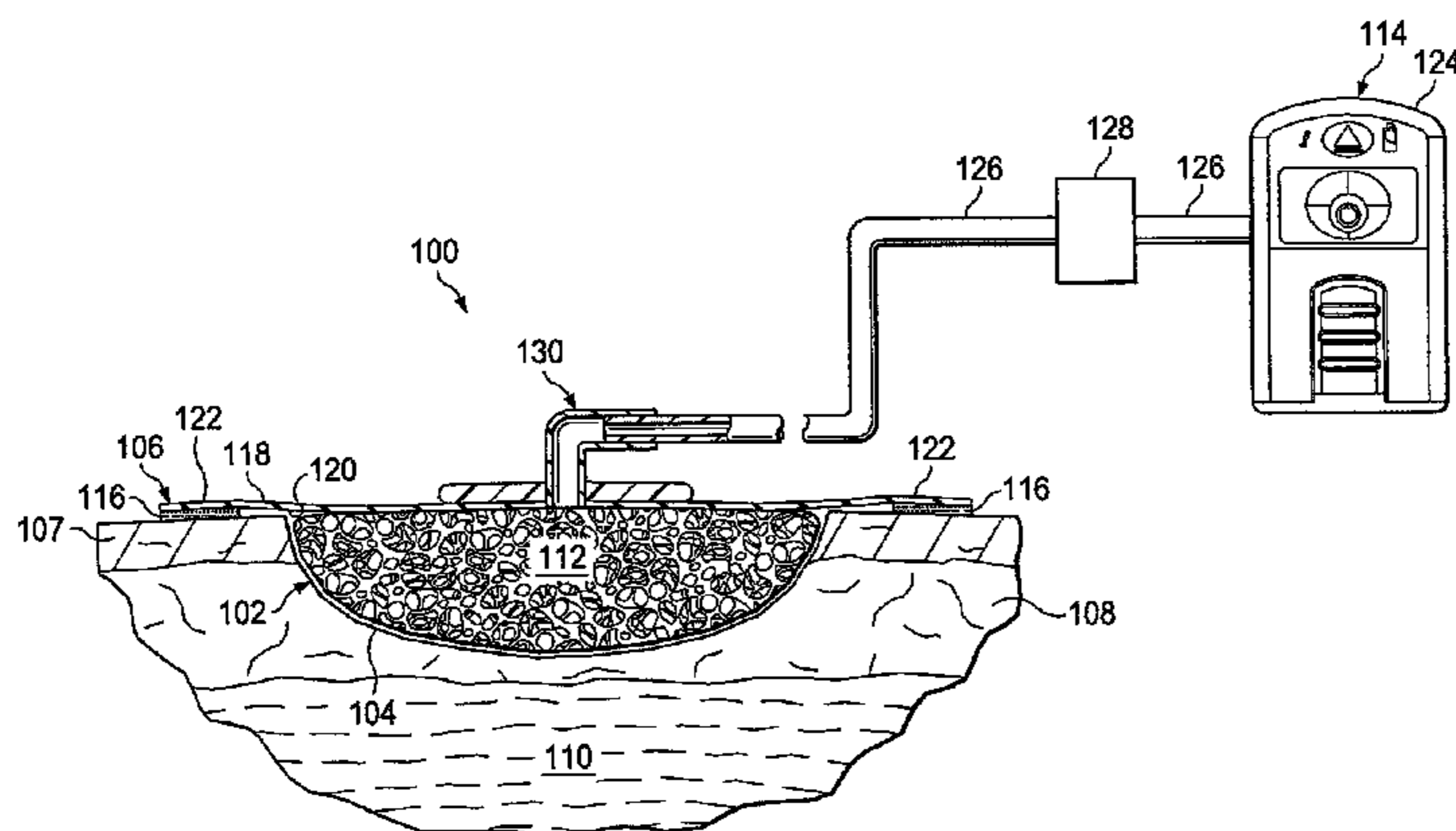

**Related U.S. Application Data**

division of application No. 13/044,381, filed on Mar. 9, 2011, now Pat. No. 8,454,580.

(60) Provisional application No. 61/313,225, filed on Mar. 12, 2010.

(52) **U.S. Cl.**

CPC .. *A61F 13/00038* (2013.01); *A61F 13/00068* (2013.01); *A61M 1/0088* (2013.01); *A61F 2013/0054* (2013.01); *A61F 2013/00119* (2013.01); *A61F 2013/00174* (2013.01); *A61F 2013/00536* (2013.01); *Y10T 83/02* (2015.04); *Y10T 156/1056* (2015.01)

(56) **References Cited**

U.S. PATENT DOCUMENTS

2,632,443	A	3/1953	Leshner
2,682,873	A	7/1954	Evans et al.
2,910,763	A	11/1959	Lauterbach
2,969,057	A	1/1961	Simmons
3,066,672	A	12/1962	Crosby, Jr. et al.
3,367,332	A	2/1968	Groves
3,520,300	A	7/1970	Flower, Jr.
3,568,675	A	3/1971	Harvey
3,648,692	A	3/1972	Wheeler
3,682,180	A	8/1972	McFarlane
3,826,254	A	7/1974	Mellor
4,080,970	A	3/1978	Miller
4,096,853	A	6/1978	Weigand
4,139,004	A	2/1979	Gonzalez, Jr.
4,165,748	A	8/1979	Johnson
4,184,510	A	1/1980	Murry et al.
4,233,969	A	11/1980	Lock et al.
4,245,630	A	1/1981	Lloyd et al.
4,256,109	A	3/1981	Nichols
4,261,363	A	4/1981	Russo
4,275,721	A	6/1981	Olson
4,284,079	A	8/1981	Adair
4,297,995	A	11/1981	Golub
4,333,468	A	6/1982	Geist
4,373,519	A	2/1983	Errede et al.
4,382,441	A	5/1983	Svedman
4,392,853	A	7/1983	Muto
4,392,858	A	7/1983	George et al.
4,419,097	A	12/1983	Rowland
4,465,485	A	8/1984	Kashmer et al.
4,475,909	A	10/1984	Eisenberg
4,480,638	A	11/1984	Schmid
4,525,166	A	6/1985	Leclerc
4,525,374	A	6/1985	Vaillancourt
4,540,412	A	9/1985	Van Overloop
4,543,100	A	9/1985	Brodsky
4,548,202	A	10/1985	Duncan
4,551,139	A	11/1985	Plaas et al.
4,569,348	A	2/1986	Hasslinger
4,600,001	A	7/1986	Gilman
4,605,399	A	8/1986	Weston et al.
4,608,041	A	8/1986	Nielsen
4,640,688	A	2/1987	Hauser
4,655,754	A	4/1987	Richmond et al.
4,664,662	A	5/1987	Webster
4,710,165	A	12/1987	McNeil et al.
4,733,659	A	3/1988	Edenbaum et al.
4,743,232	A	5/1988	Kruger
4,758,220	A	7/1988	Sundblom et al.
4,787,888	A	11/1988	Fox
4,826,494	A	5/1989	Richmond et al.
4,838,883	A	6/1989	Matsuura
4,840,187	A	6/1989	Brazier
4,863,449	A	9/1989	Therriault et al.
4,872,450	A	10/1989	Austad
4,878,901	A	11/1989	Sachse
4,897,081	A	1/1990	Poirier et al.

4,906,233	A	3/1990	Moriuchi et al.
4,906,240	A	3/1990	Reed et al.
4,919,654	A	4/1990	Kalt
4,941,882	A	7/1990	Ward et al.
4,953,565	A	9/1990	Tachibana et al.
4,969,880	A	11/1990	Zamierowski
4,985,019	A	1/1991	Michelson
5,037,397	A	8/1991	Kalt et al.
5,086,170	A	2/1992	Luheshi et al.
5,092,858	A	3/1992	Benson et al.
5,100,396	A	3/1992	Zamierowski
5,134,994	A	8/1992	Say
5,149,331	A	9/1992	Ferdman et al.
5,167,613	A	12/1992	Karami et al.
5,176,663	A	1/1993	Svedman et al.
5,215,522	A	6/1993	Page et al.
5,232,453	A	8/1993	Plass et al.
5,261,893	A	11/1993	Zamierowski
5,278,100	A	1/1994	Doan et al.
5,279,550	A	1/1994	Habib et al.
5,298,015	A	3/1994	Komatsuzaki et al.
5,342,376	A	8/1994	Ruff
5,344,415	A	9/1994	DeBusk et al.
5,358,494	A	10/1994	Svedman
5,437,622	A	8/1995	Canon
5,437,651	A	8/1995	Todd et al.
5,527,293	A	6/1996	Zamierowski
5,549,584	A	8/1996	Gross
5,556,375	A	9/1996	Ewall
5,607,388	A	3/1997	Ewall
5,636,643	A	6/1997	Argenta et al.
5,645,081	A	7/1997	Argenta et al.
6,018,092	A *	1/2000	Dunshee ..... A61F 15/001 206/440
6,071,267	A	6/2000	Zamierowski
6,135,116	A	10/2000	Vogel et al.
6,241,747	B1	6/2001	Ruff
6,287,316	B1	9/2001	Agarwal et al.
6,345,623	B1	2/2002	Heaton et al.
6,488,643	B1	12/2002	Tumey et al.
6,493,568	B1	12/2002	Bell et al.
6,553,998	B2	4/2003	Heaton et al.
6,814,079	B2	11/2004	Heaton et al.
8,454,580	B2 *	6/2013	Locke ..... A61F 13/00029 604/313
2002/0077661	A1	6/2002	Saadat
2002/0115951	A1	8/2002	Norstrem et al.
2002/0120185	A1	8/2002	Johnson
2002/0143286	A1	10/2002	Tumey
2007/0027414	A1 *	2/2007	Hoffman ..... A61M 1/0088 602/2

FOREIGN PATENT DOCUMENTS

AU	755496	B2	12/2002
CA	2005436	A1	6/1990
DE	26 40 413	A1	3/1978
DE	43 06 478	A1	9/1994
DE	29 504 378	U1	9/1995
EP	0100148	A1	2/1984
EP	0117632	A2	9/1984
EP	0161865	A2	11/1985
EP	0358302	A2	3/1990
EP	1018967	A1	7/2000
GB	692578	A	6/1953
GB	2 195 255	A	4/1988
GB	2 197 789	A	6/1988
GB	2 220 357	A	1/1990
GB	2 235 877	A	3/1991
GB	2 329 127	A	3/1999
GB	2 333 965	A	8/1999
JP	4129536	B2	8/2008
SG	71559		4/2002
WO	80/02182	A1	10/1980
WO	87/04626	A1	8/1987
WO	90/010424	A1	9/1990
WO	93/009727	A1	5/1993
WO	94/020041	A1	9/1994
WO	96/05873	A1	2/1996

(56)

## References Cited

## FOREIGN PATENT DOCUMENTS

WO	97/18007	A1	5/1997
WO	98/38955	A1	9/1998
WO	99/13793	A1	3/1999
WO	2008/100440	A1	8/2008
WO	2011/112870	A1	9/2011

## OTHER PUBLICATIONS

Susan Mendez-Eatmen, RN; "When wounds Won't Heal" RN Jan. 1998, vol. 61 (1); Medical Economics Company, Inc., Montvale, NJ, USA; pp. 20-24.

James H. Blackburn II, MD et al.: Negative-Pressure Dressings as a Bolster for Skin Grafts; *Annals of Plastic Surgery*, vol. 40, No. 5, May 1998, pp. 453-457; Lippincott Williams & Wilkins, Inc., Philadelphia, PA, USA.

John Masters; "Reliable, Inexpensive and Simple Suction Dressings"; Letter to the Editor, *British Journal of Plastic Surgery*, 198, vol. 51 (3), p. 267; Elsevier Science/The British Association of Plastic Surgeons, UK.

S.E. Greer, et al. "The Use of Subatmospheric Pressure Dressing Therapy to Close Lymphocutaneous Fistulas of the Groin" *British Journal of Plastic Surgery* (2000), 53, pp. 484-487.

George V. Letsou, MD., et al; "Stimulation of Adenylate Cyclase Activity in Cultured Endothelial Cells Subjected to Cyclic Stretch"; *Journal of Cardiovascular Surgery*, 31, 1990, pp. 634-639.

Orringer, Jay, et al; "Management of Wounds in Patients with Complex Enterocutaneous Fistulas"; *Surgery, Gynecology & Obstetrics*, Jul. 1987, vol. 165, pp. 79-80.

International Search Report for PCT International Application PCT/GB95/01983; dated Nov. 23, 1995.

PCT International Search Report for PCT International Application PCT/GB98/02713; dated Jan. 8, 1999.

PCT Written Opinion; PCT International Application PCT/GB98/02713; dated Jun. 8, 1999.

PCT International Examination and Search Report, PCT International Application PCT/GB96/02802; dated Jan. 15, 1998 & Apr. 29, 1997.

PCT Written Opinion, PCT International Application PCT/GB96/02802; dated Sep. 3, 1997.

Dattilo, Philip P., Jr., et al; "Medical Textiles: Application of an Absorbable Barbed Bi-directional Surgical Suture"; *Journal of Textile and Apparel, Technology and Management*, vol. 2, Issue 2, Spring 2002, pp. 1-5.

Kostyuchenok, B.M., et al; "Vacuum Treatment in the Surgical Management of Purulent Wounds"; *Vestnik Khirurgi*, Sep. 1986, pp. 18-21 and 6 page English translation thereof.

Davydov, Yu. A., et al; "Vacuum Therapy in the Treatment of Purulent Lactation Mastitis"; *Vestnik Khirurgi*, May 14, 1986, pp. 66-70, and 9 page English translation thereof.

Yusupov, Yu.N., et al; "Active Wound Drainage"; *Vestniki Khirurgi*, vol. 138, Issue 4, 1987, and 7 page English translation thereof.

Davydov, Yu.A., et al; "Bacteriological and Cytological Assessment of Vacuum Therapy for Purulent Wounds"; *Vestnik Khirurgi*, Oct. 1988, pp. 48-52, and 8 page English translation thereof.

Davydov, Yu.A., et al; "Concepts for the Clinical-Biological Management of the Wound Process in the Treatment of Purulent Wounds by Means of Vacuum Therapy"; *Vestnik Khirurgi*, Jul. 7, 1980, pp. 132-136, and 8 page English translation thereof.

Chariker, Mark E., M.D., et al; "Effective Management of incisional and cutaneous fistulae with closed suction wound drainage"; *Contemporary Surgery*, vol. 34, Jun. 1989, pp. 59-63.

Egnell Minor, Instruction Book, First Edition, 300 7502, Feb. 1975, pp. 24.

Egnell Minor: Addition to the Users Manual Concerning Overflow Protection—Concerns all Egnell Pumps, Feb. 3, 1983, pp. 2.

Svedman, P.: "Irrigation Treatment of Leg Ulcers", *The Lancet*, Sep. 3, 1983, pp. 532-534.

Chinn, Steven D. et al.: "Closed Wound Suction Drainage", *The Journal of Foot Surgery*, vol. 24, No. 1, 1985, pp. 76-81.

Arnljots, Bjorn et al.: "Irrigation Treatment in Split-Thickness Skin Grafting of Intractable Leg Ulcers", *Scand J. Plast Reconstr. Surg.*, No. 19, 1985, pp. 211-213.

Svedman, P.: "A Dressing Allowing Continuous Treatment of a Biosurface", *IRCS Medical Science: Biomedical Technology, Clinical Medicine, Surgery and Transplantation*, vol. 7, 1979, p. 221.

Svedman, P. et al: "A Dressing System Providing Fluid Supply and Suction Drainage Used for Continuous or Intermittent Irrigation", *Annals of Plastic Surgery*, vol. 17, No. 2, Aug. 1986, pp. 125-133.

N.A. Bagautdinov, "Variant of External Vacuum Aspiration in the Treatment of Purulent Diseases of Soft Tissues," *Current Problems in Modern Clinical Surgery: Interdepartmental Collection*, edited by V. Ye Volkov et al. (Chuvashia State University, Cheboksary, U.S.S.R. 1986); pp. 94-96 (copy and certified translation).

K.F. Jeter, T.E. Tittle, and M. Chariker, "Managing Draining Wounds and Fistulae: New and Established Methods," *Chronic Wound Care*, edited by D. Krasner (Health Management Publications, Inc., King of Prussia, PA 1990), pp. 240-246.

G. Živadinovi?, V. ?uki?, Ž. Maksimovi?, ?. Radak, and P. Peška, "Vacuum Therapy in the Treatment of Peripheral Blood Vessels," *Timok Medical Journal* 11 (1986), pp. 161-164 (copy and certified translation).

F.E. Johnson, "An Improved Technique for Skin Graft Placement Using a Suction Drain," *Surgery, Gynecology, and Obstetrics* 159 (1984), pp. 584-585.

A.A. Safronov, Dissertation Abstract, Vacuum Therapy of Trophic Ulcers of the Lower Leg with Simultaneous Autoplasty of the Skin (Central Scientific Research Institute of Traumatology and Orthopedics, Moscow, U.S.S.R. 1967) (copy and certified translation).

M. Schein, R. Saadia, J.R. Jamieson, and G.A.G. Decker, "The 'Sandwich Technique' in the Management of the Open Abdomen," *British Journal of Surgery* 73 (1986), pp. 369-370.

D.E. Tribble, An Improved Sump Drain-Irrigation Device of Simple Construction, *Archives of Surgery* 105 (1972) pp. 511-513.

M.J. Morykwas, L.C. Argenta, E.I. Shelton-Brown, and W. McGuirt, "Vacuum-Assisted Closure: A New Method for Wound Control and Treatment: Animal Studies and Basic Foundation," *Annals of Plastic Surgery* 38 (1997), pp. 553-562 (Morykwas I).

C.E. Tennants, "The Use of Hyperemia in the Postoperative Treatment of Lesions of the Extremities and Thorax," *Journal of the American Medical Association* 64 (1915), pp. 1548-1549.

Selections from W. Meyer and V. Schmieden, Bier's Hyperemic Treatment in Surgery, Medicine, and the Specialties: A Manual of Its Practical Application, (W.B. Saunders Co., Philadelphia, PA 1909), pp. 17-25, 44-64, 90-96, 167-170, and 210-211.

V.A. Solovev et al., Guidelines, The Method of Treatment of Immature External Fistulas in the Upper Gastrointestinal Tract, editor-in-chief Prov. V.I. Parahonyak (S.M. Kirov Gorky State Medical Institute, Gorky, U.S.S.R. 1987) ("Solovev Guidelines").

V.A. Kuznetsov & N.a. Bagautdinov, "Vacuum and Vacuum-Sorption Treatment of Open Septic Wounds," in II All-Union Conference on Wounds and Wound Infections: Presentation Abstracts, edited by B.M. Kostyuchenok et al. (Moscow, U.S.S.R. Oct. 28-29, 1986) pp. 91-92 ("Bagautdinov II").

V.A. Solovev, Dissertation Abstract, Treatment and Prevention of Suture Failures after Gastric Resection (S.M. Kirov Gorky State Medical Institute, Gorky, U.S.S.R. 1988) ("Solovev Abstract").

V.A.C. ® Therapy Clinical Guidelines: A Reference Source for Clinicians; Jul. 2007.

Japanese First Office Action/Notice of Rejection, corresponding to JP 2015-183696, dated 2016-06-28. (Some English).

\* cited by examiner

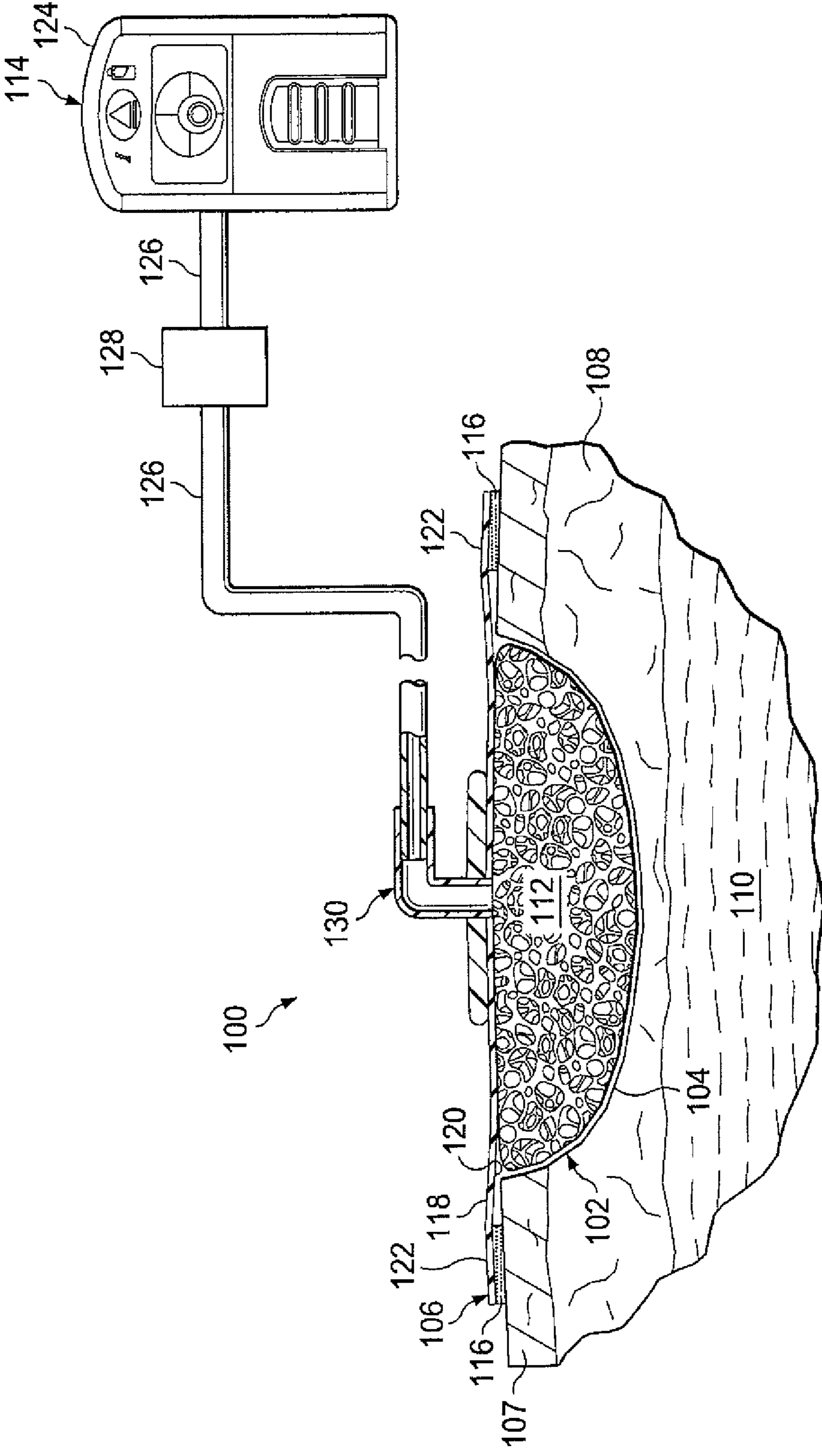

FIG. 1

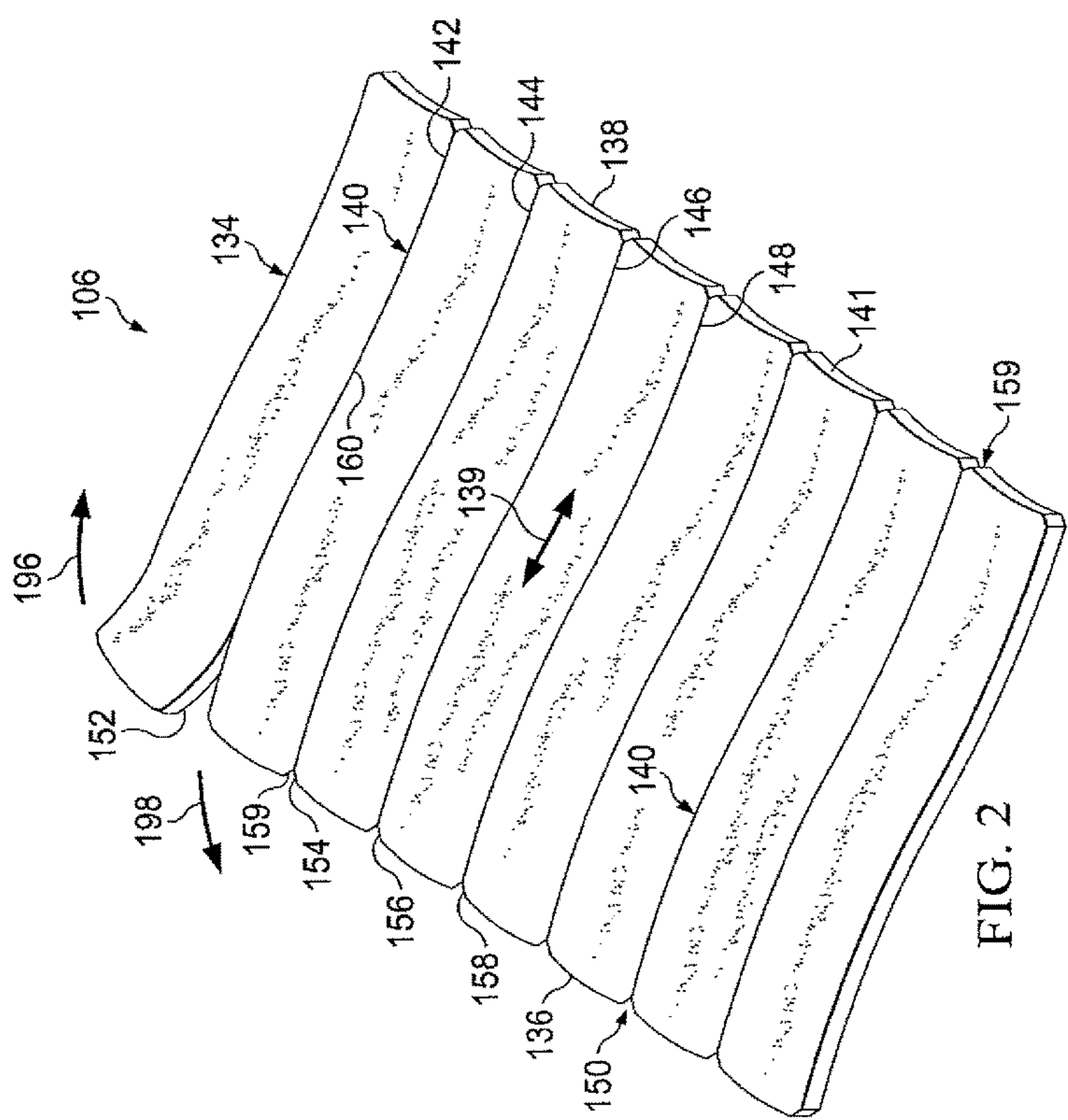

FIG. 2

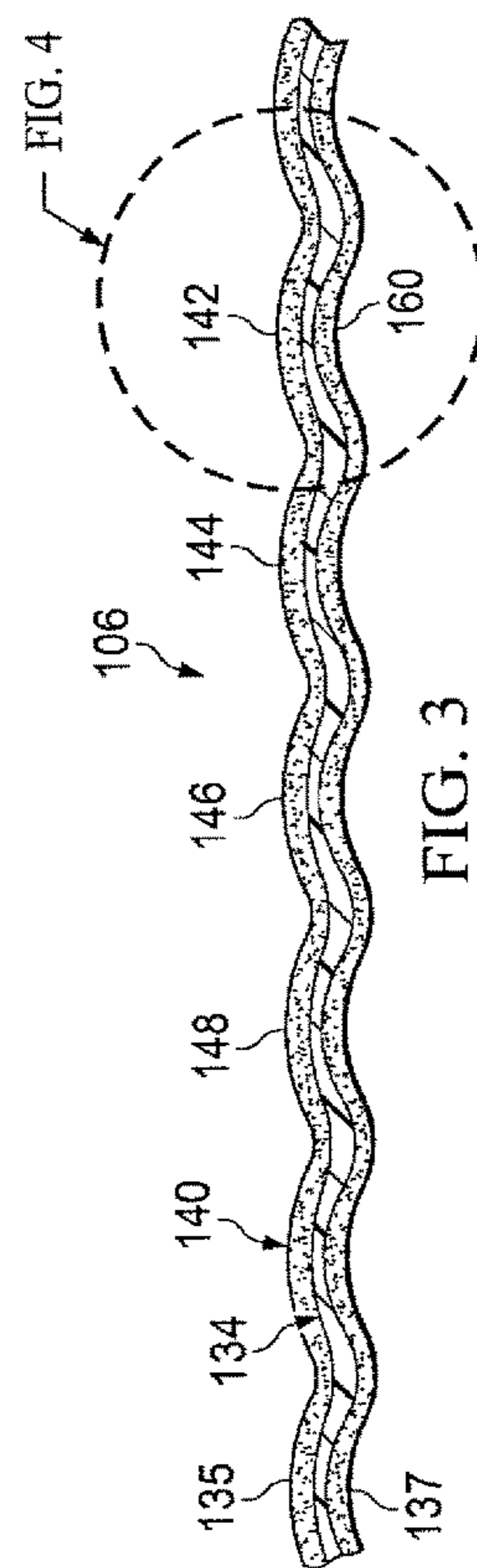

FIG. 3

FIG. 4

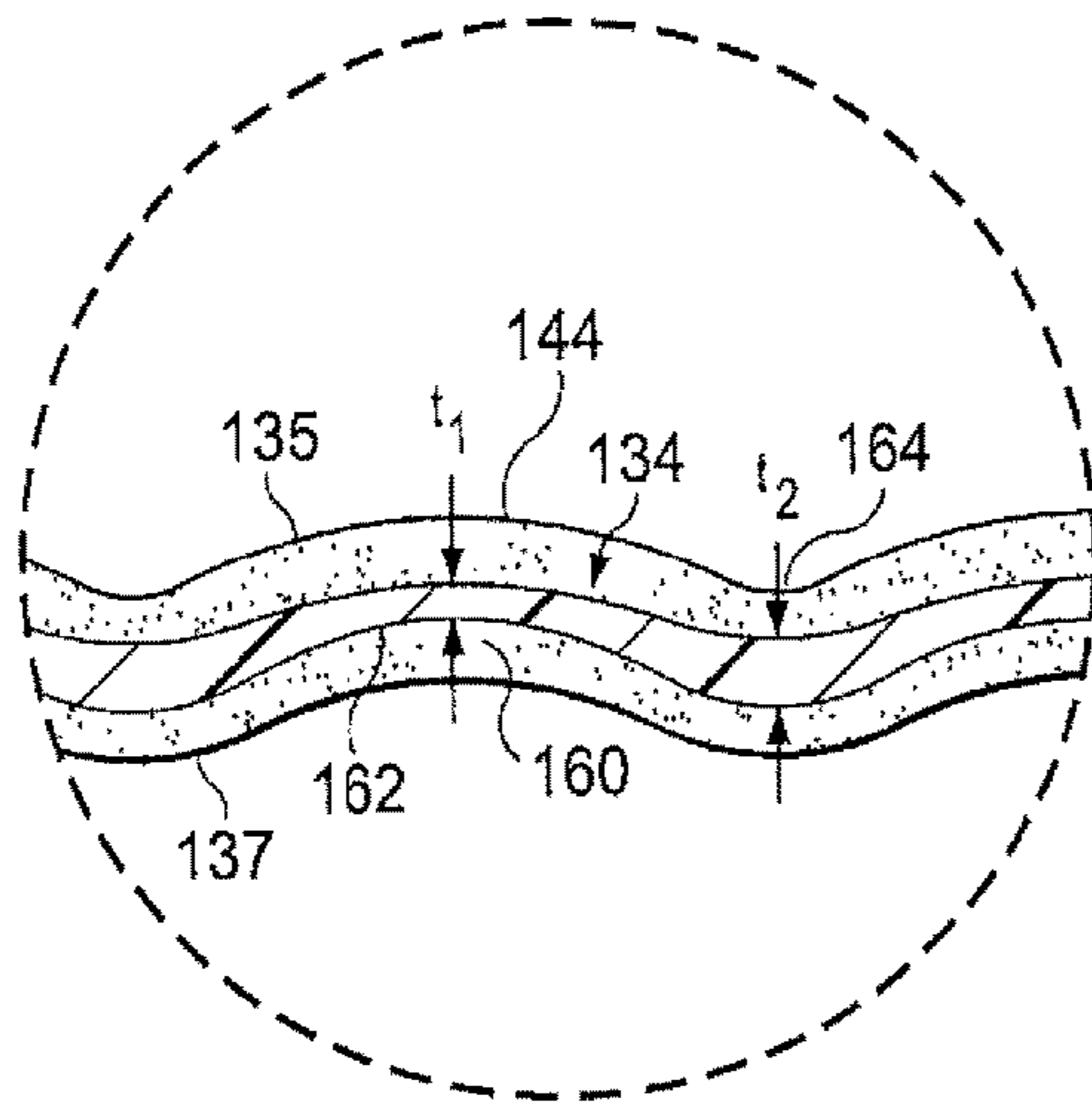

FIG. 4

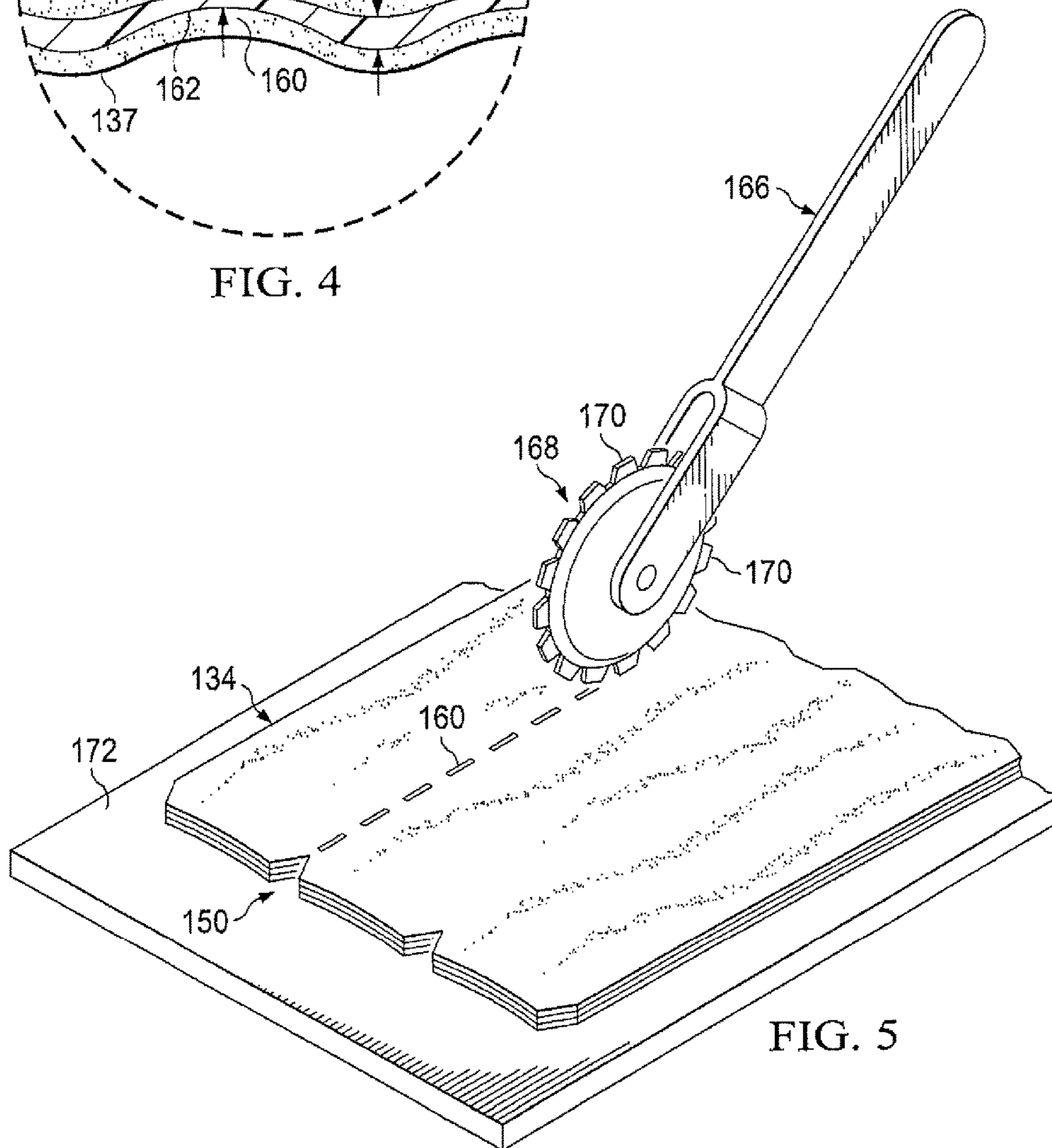
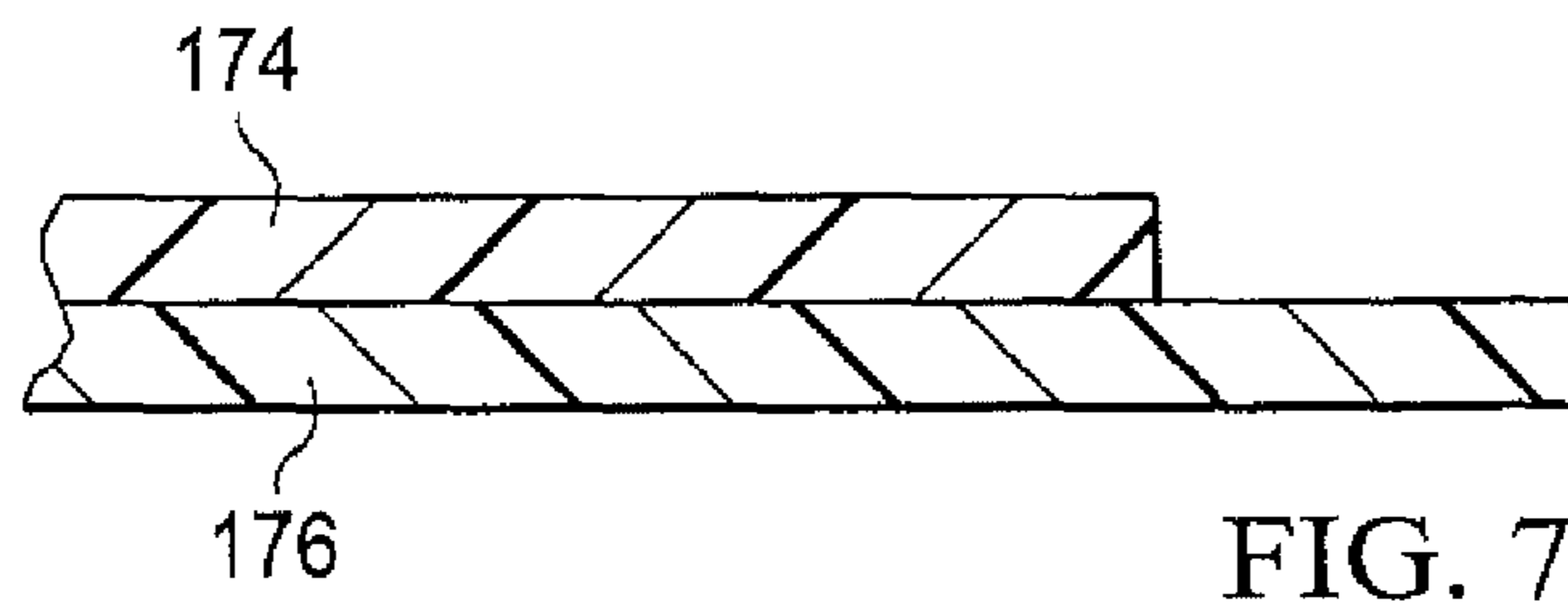
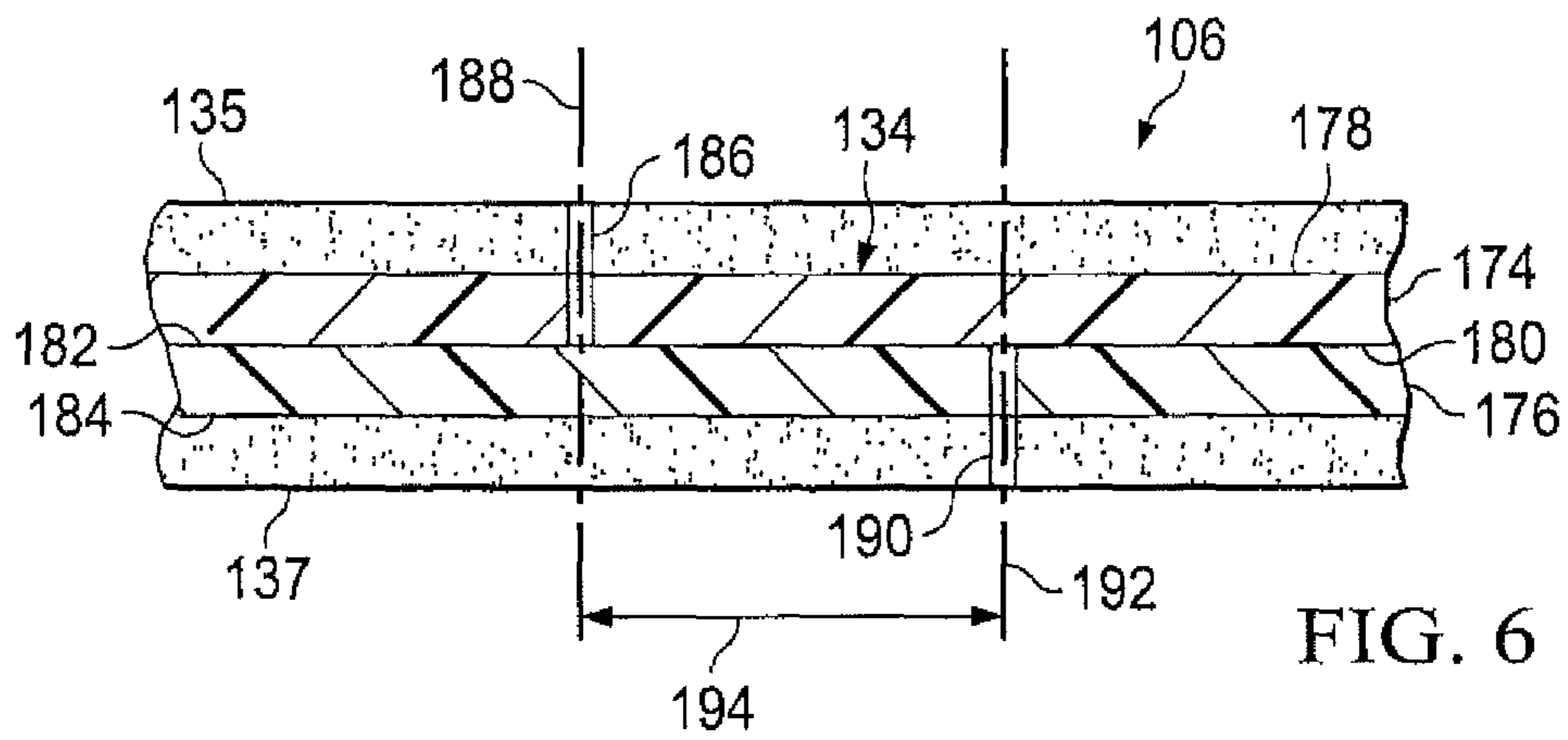

FIG. 5



## ADJUSTABLE REDUCED-PRESSURE WOUND COVERINGS

### RELATED APPLICATION

The present invention is a continuation of U.S. patent application Ser. No. 13/875,085, filed May 1, 2013, which is a divisional of U.S. patent application Ser. No. 13/044,381, filed Mar. 9, 2011 which claims the benefit, under 35 USC § 119(e), of the filing of U.S. Provisional Patent Application Ser. No. 61/313,225, entitled "Adjustable Reduced-Pressure Wound Coverings," filed 12 Mar. 2010, which is incorporated herein by reference for all purposes.

### BACKGROUND

The present disclosure relates generally to medical treatment systems and, more particularly, to adjustable reduced-pressure wound coverings.

Clinical studies and practice have shown that providing a reduced pressure in proximity to a tissue site augments and accelerates the growth of new tissue at the tissue site. The applications of this phenomenon are numerous, but application of reduced pressure has been particularly successful in treating wounds. This treatment (frequently referred to in the medical community as "negative pressure wound therapy," "reduced pressure therapy," or "vacuum therapy") provides a number of benefits, which may include faster healing and increased formulation of granulation tissue. Typically, reduced pressure is applied to tissue through a porous pad or other manifold device. The porous pad distributes reduced pressure to the tissue and channels fluids that are drawn from the tissue. The porous pad is typically covered by a covering, or drape.

### SUMMARY

According to an illustrative, non-limiting embodiment, a reduced-pressure treatment system for treating a tissue site on a patient includes a manifold for placing proximate to the tissue site, an adjustable covering for forming a fluid seal over the manifold and a portion of the patient's epidermis, a reduced-pressure interface coupled to the adjustable covering for providing reduced pressure through the adjustable covering, and a reduced-pressure source fluidly coupled to the reduced-pressure interface. The adjustable covering includes a drape member having a first initiation edge and a second initiation edge and having a first side and a second, patient-facing side. The adjustable covering has a plurality of non-leaking tear paths formed on the drape member. Each non-leaking tear path includes a weakened path of the drape member that may be torn by hand. The adjustable cover also may include a first plurality of tear starters formed on a first initiation edge of the drape member. Each tear starter of the first plurality of tear starters is aligned with one of the plurality of tear paths. Each of the first plurality of tear starters is adapted to facilitate the initiation of a tear along a tear path.

According to another illustrative, non-limiting embodiment, an adjustable covering for use with a reduced-pressure treatment system includes a drape member having a first initiation edge and a second initiation edge and having a first side and a second, patient-facing side. The adjustable covering further includes a plurality of non-leaking tear paths formed on the drape member. Each non-leaking tear path includes a weakened path of the drape member that may be torn. The adjustable covering further includes a first plurality

of tear starters formed on a first initiation edge of the drape member. Each tear starter of the first plurality of tear starters is aligned with one of the plurality of tear paths. Each of the first plurality of tear starters is adapted to facilitate the initiation of a tear along a tear path.

According to another illustrative, non-limiting embodiment, a method of treating a tissue site on a patient with reduced pressure includes placing a manifold proximate to the tissue site, sizing an adjustable covering to fit over the manifold and a portion of the patient's epidermis to form a fluid seal, and fluidly coupling a reduced-pressure source to the adjustable covering to provide reduced pressure to the manifold. The adjustable covering includes a drape member having a first initiation edge and a second initiation edge and having a first side and a second, patient-facing side. The adjustable covering further includes a plurality of non-leaking tear paths formed on the drape member. Each non-leaking tear path includes a weakened path of the drape member that may be torn by hand. The adjustable covering also may include a first plurality of tear starters formed on a first initiation edge of the drape member. Each tear starter of the first plurality of tear starters is aligned with one of the plurality of tear paths. Each of the first plurality of tear starters is adapted to facilitate the initiation of a tear along a tear path. The step of sizing the adjustable drape includes tearing the drape member along at least one of the plurality of tear paths to present a smaller adjustable covering.

According to another illustrative, non-limiting embodiment, a method of manufacturing an adjustable covering for use with a reduced-pressure treatment system includes forming a drape member having a first initiation edge and a second initiation edge and having a first side and a second, patient-facing side. The method also includes forming a plurality of non-leaking tear paths on the drape member. Each non-leaking tear path includes a weakened path of the drape member that may be torn. The method further includes forming a first plurality of tear starters on a first initiation edge of the drape material. Each tear starter of the first plurality of tear starters is aligned with one of the plurality of tear paths. Each of the first plurality of tear starters is adapted to facilitate the initiation of a tear along a tear path.

Other objects and advantages of the illustrative embodiments will become apparent with reference to the drawings and detailed description that follow.

### BRIEF DESCRIPTION OF THE DRAWINGS

FIG. 1 is a schematic diagram with a portion shown in cross section of an illustrative, non-limiting embodiment of a reduced-pressure treatment system with an adjustable covering;

FIG. 2 is a schematic, perspective view of an illustrative, non-limiting embodiment of an adjustable covering;

FIG. 3 is a schematic cross section of the adjustable covering of FIG. 2;

FIG. 4 is a detail of a portion of the adjustable covering shown in FIG. 3;

FIG. 5 is a schematic, perspective view of a tool creating an illustrative non-leaking tear path on an adjustable covering;

FIG. 6 is a cross section of a portion of another illustrative embodiment of an adjustable covering with a tear path; and

FIG. 7 is the cross section of FIG. 6 after the tear path has been torn and a support layer and a backing layer have been removed.



## DETAILED DESCRIPTION OF ILLUSTRATIVE EMBODIMENTS

In the following detailed description of the illustrative embodiments, reference is made to the accompanying drawings that form a part hereof. These embodiments are described in sufficient detail to enable those skilled in the art to practice the invention, and it is understood that other embodiments may be utilized and that logical structural, mechanical, electrical, and chemical changes may be made without departing from the spirit or scope of the invention. To avoid detail not necessary to enable those skilled in the art to practice the embodiments described herein, the description may omit certain information known to those skilled in the art. The following detailed description is, therefore, not to be taken in a limiting sense, and the scope of the illustrative embodiments are defined only by the appended claims.

Referring to the drawings and primarily to FIG. 1, a reduced-pressure treatment system **100** for treating a tissue site **102** is presented that includes an adjustable covering **106**. The tissue site **102** may be, for example, a wound **104**. The wound **104** may include, without limitation, any irregularity with a tissue, such as an open wound, surgical incision, or diseased tissue. The wound **104** is shown extending through the epidermis **107**, or generally skin, and the dermis **108** and reaching into a hypodermis, or subcutaneous tissue **110**. The reduced-pressure treatment system **100** may be used to treat a tissue, such as a wound of any depth, as well as many different types of tissue sites including open wounds or intact tissue. The tissue site **102** may be the bodily tissue of any human, animal, or other organism, including bone tissue, adipose tissue, muscle tissue, dermal tissue, vascular tissue, connective tissue, cartilage, tendons, ligaments, or any other tissue.

The reduced-pressure treatment system **100** may include a manifold **112**, the adjustable covering **106**, and a reduced-pressure subsystem **114**. The manifold **112** is operable to distribute reduced pressure. The adjustable covering **106** provides a fluid seal over the tissue site **102**. "Fluid seal," or "seal," means a seal adequate to maintain reduced pressure at a desired site given the particular reduced-pressure source or subsystem involved. The adjustable covering **106** may be sized by the healthcare provider at the time of application by hand without requiring cutting tools. The reduced-pressure treatment system **100** may include an attachment device **116** to help form a fluid seal between the adjustable covering **106** and the patient's epidermis **107**. The adjustable covering **106** has a first side **118** and a second, patient-facing side **120**. The manifold **112** is positioned between the second, patient-facing (inward-facing) side **120** of the adjustable covering **106** and the tissue site **102**.

The term "manifold" as used herein generally refers to a substance or structure that is provided to assist in applying reduced pressure to, delivering fluids to, or removing fluids from a tissue site, e.g., tissue site **102**. The manifold **112** typically includes a plurality of flow channels or pathways to distribute fluids provided to and remove fluids from around the manifold **112**. The plurality of flow channels or pathways may be interconnected. The manifold **112** may be a biocompatible material that is capable of being placed in contact with a tissue site, e.g., tissue site **102**, and distributing reduced pressure to the tissue site **102**. Examples of manifold members may include, without limitation, devices that have structural elements arranged to form flow channels, such as, for example, cellular foam, open-cell foam, porous tissue collections, and foams that include, or cure to

include, flow channels. Thus, for example, the manifold **112** may be porous and may be made from foam, gauze, felted mat, or other material. The manifold **112** may be formed directly from a porous material, e.g., a foam, or from a material that is made porous, e.g., a solid member in which apertures have been applied.

As a non-limiting example, the porous foam may be a polyurethane, open-cell, reticulated foam, such as a Granu-Foam® material manufactured by Kinetic Concepts, Incorporated of San Antonio, Tex., or Granufoam Silver® material manufactured by Kinetic Concepts, Incorporated of San Antonio, Tex. As another non-limiting example, a polyvinyl alcohol foam, such as White Foam, which also available from Kinetic Concepts, Incorporated of San Antonio, Tex., might be used in some situations.

As will be described further below, the adjustable covering **106** may be sized so that the adjustable covering **106** overlaps the wound **104** in such a manner that a portion of the adjustable covering **106** extends beyond the periphery of the wound **104** to form an extension **122**. The adjustable covering **106** may be formed from any material that provides a fluid seal. The adjustable covering **106** may, for example, be an impermeable or semi-permeable, elastomeric material. "Elastomeric" means having the properties of an elastomer. Elastomeric material generally refers to a polymeric material that has rubber-like properties. More specifically, most elastomers have ultimate elongations greater than 100% and a significant amount of resilience. The resilience of a material refers to the material's ability to recover from an elastic deformation. Examples of elastomers may include, but are not limited to, natural rubbers, polyisoprene, styrene butadiene rubber, chloroprene rubber, polybutadiene, nitrile rubber, butyl rubber, ethylene propylene rubber, ethylene propylene diene monomer, chlorosulfonated polyethylene, polysulfide rubber, polyurethane (PU), EVA film, co-polyester, and silicones. Additional, specific examples of sealing member materials include a silicone drape, a 3M Tegaderm® drape, or a polyurethane (PU) drape such as one available from Avery Dennison Corporation of Pasadena, Calif.

The adjustable covering **106** in some of the present embodiments may be selected to be less elastomeric in nature. In these embodiments, the material allows for at least some plastic deformation or permanent stretching in response to a local stretching tool (e.g., local stretching tool **166** in FIG. 5) while maintaining the ability to stretch at least some.

The attachment device **116** may be used to attach the adjustable covering **106** to the patient's epidermis **107** or another layer, such as a gasket or additional sealing member. The attachment device **116** may take numerous forms. For example, the attachment device **116** may be a medically-acceptable, pressure-sensitive adhesive that is applied to the extension **122** of the adjustable covering **106**. Alternatively, the pressure-sensitive adhesive may span the entire width of the adjustable covering **106**. Alternative attachment devices may include, but are not limited to, heat-activated adhesives, sealing tapes, double-sided sealing tapes, pastes, hydrocolloids, hydrogels, hooks, sutures, or other device.

The reduced-pressure subsystem **114** includes a reduced-pressure source **124**, which can take many different forms. The reduced-pressure source **124** provides reduced pressure. The reduced-pressure source **124** may be any device for supplying a reduced pressure, such as a vacuum pump, wall suction, or other source. While the amount and nature of reduced pressure applied to tissue site **102** will typically vary according to the application, the reduced pressure will

typically be between  $-5$  mm Hg and  $-500$  mm Hg and more typically between  $-100$  mm Hg and  $-300$  mm Hg. For example, and not by way of limitation, the pressure may be  $-90$ ,  $-100$ ,  $-110$ ,  $-120$ ,  $-130$ ,  $-140$ ,  $-150$ ,  $-160$ ,  $-170$ ,  $-180$ ,  $-190$ ,  $-200$  mm Hg or another pressure.

As used herein, “reduced pressure” generally refers to a pressure less than the ambient pressure at a tissue site that is being subjected to treatment. In most cases, this reduced pressure will be less than the atmospheric pressure at which the patient is located. Alternatively, the reduced pressure may be less than a hydrostatic pressure at the tissue site. The reduced pressure delivered may be constant, varied (patterned or random) and may be delivered continuously or intermittently. Unless otherwise indicated, values of pressure stated herein are gauge pressures. Although the terms “vacuum” and “negative pressure” may be used to describe the pressure applied to the tissue site, the actual pressure applied to the tissue site may be more than the pressure normally associated with a complete vacuum. Consistent with the use herein, an increase in reduced pressure or vacuum pressure typically refers to a relative reduction in absolute pressure.

The reduced pressure developed by the reduced-pressure source **124** is delivered through the reduced-pressure conduit **126**, through canister **128**, to a reduced-pressure interface **130**. In one illustrative embodiment, the reduced-pressure interface **130** is a TRAC® technology port available from Kinetic Concepts, Inc. of San Antonio, Tex. The reduced-pressure interface **130** allows the reduced pressure to be realized within a sealed space below the adjustable covering **106** and realized within the manifold **112**.

In operation, the manifold **112** may be placed proximate the tissue site **102**, e.g., wound **104**. The adjustable covering **106** may be adjusted to the desired size and placed over the manifold **112** such that the extension **122** extends beyond the periphery of the wound **104**. The extension **122** may be secured to the patient’s epidermis **107** by the attachment device **116** in order to form a fluid seal over a portion of the patient’s epidermis **107** and the manifold **112**. The reduced-pressure interface **130** may then be applied, if not already installed. The reduced-pressure conduit **126** is fluidly coupled to the reduced-pressure interface **130** and fluidly coupled to the reduced-pressure source **124**.

The reduced-pressure subsystem **114** may be activated. Under reduced pressure, fluids will be delivered from the tissue site **102** to the manifold **112** and through the reduced-pressure conduit **126** to the canister **128**.

In applying the reduced-pressure treatment system **100**, the manifold **112** may have pre-cuts that allow the healthcare provider to size the manifold **112** to approximately the same size as the wound **104** or to a size desired for treatment. Likewise, the adjustable covering **106** has non-leaking tear paths that facilitate sizing without requiring cutting tools.

Referring now primarily to FIGS. 2-5, an illustrative, non-limiting embodiment of the adjustable covering **106** having a plurality of non-leaking flow paths **140** is presented. The adjustable covering **106** includes a drape member **134** having a first initiation edge **136** and a second initiation edge **138**. The adjustable covering **106** may have a releaseable support layer **135** and a releaseable backing layer **137**. The releaseable backing layer **137** may initially cover the attachment device **116** (FIG. 1; not explicitly shown in FIGS. 2-4) and is releasably coupled to the second, patient-facing side **120** of adjustable covering **106**. The support layer **135** may be releasably coupled to the first side **118** of the adjustable covering **106** and may provide extra

support to the adjustable covering **106** while the adjustable covering **106** is being deployed or prepared for deployment.

The drape member **134** may be formed with a grain or a drape grain **139**. Analogous to cutting with or across a grain on a piece of wood, the drape member **134** is inherently easier to tear in the direction of the drape grain **139** and more difficult to tear cross-grain. In the illustrative embodiment of FIG. 2, the drape grain **139** is shown in a first direction that is parallel to a plurality of non-leaking tear paths **140**. Similarly, the support layer **135** and the releaseable backing layer **137** may each have a grain, i.e., the support grain and backing grain, respectively. To facilitate tearing along the plurality of non-leaking tear paths **140**, the drape grain **139**, support grain, and backing grain may all be aligned in the same direction.

The adjustable covering **106** is formed with the plurality of non-leaking tear paths **140** formed on the drape member **134**. The plurality of non-leaking tear paths **140** may be linear as shown, circular, patterned, or any other shape. In the illustrative embodiment, the plurality of non-leaking tear paths **140** includes a first non-leaking tear path **142**, second non-leaking tear path **144**, third non-leaking tear path **146**, fourth non-leaking tear path **148**, etc. Each tear path of the plurality of non-leaking tear paths **140** on the first initiation edge **136** may be aligned with a tear starter of a first plurality of tear starters **150**, e.g., a first tear starter **152**, second tear starter **154**, third tear starter **156**, fourth tear starter **158**, etc.

The first plurality of tear starters **150** may be formed by forming a plurality of notches, cuts, or thinned portions on the first initiation edge **136** of the drape member **134**. The tear starters **150** may also be formed by adding a backing or platform that extends beyond a peripheral edge **141** of the drape member **134** and that has perforations that allow a healthcare provider to initiate a tear in the backing or platform before reaching an associated tear path **140**. Each tear starter of the first plurality of tear starters **150** is aligned with one of the non-leaking tear paths **140**. Each of the first plurality of tear starters **150** is adapted to facilitate the initiation of a tear along a tear path of the plurality of non-leaking tear paths **140**. In an analogous manner, a second plurality of tear starters **159** may be formed on the second initiation edge **138**.

A plurality of weakened paths **160** correspond to the plurality of non-leaking tear paths **140** to facilitate tearing. The plurality of weakened paths **160** may be formed in a number of ways. For example, the weakened paths **160** may be formed by local stretching, partial removal of drape material, or application of external energy. In one embodiment involving local stretching, the drape member **134** may be locally stretched by forming a micro-ridge **162** that stretches the drape member **134** to form a portion with a smaller thickness  $t_1$  than a thickness  $t_2$  of the un-stretched portion **164** of the drape member **134**, i.e.,  $t_1 < t_2$ .

FIG. 5 shows a local stretching tool **166**, which has a rotating wheel **168** with blunt pegs **170**, that forms the micro-ridges **162** resulting in a stretched portion with less material (i.e.,  $t_1 < t_2$ ) and thereby creating a weakened path. The blunt pegs **170** may be any impinging member that causes stretching but does not puncture the drape member **134**. A support surface **172**, either hard or soft (e.g., foam), may be placed under the drape member **134** at the time the local stretching tool **166** is pressed against the drape member **134**. This process may be done using an automated manufacturing process.

A non-limiting example of the second approach to forming the plurality of weakened paths **160** includes chemical

etching with optical masks that remove material to create lines of weakness. Material may also be removed using heat or ultrasonic ablation.

Other techniques may be used to weaken the drape member **134** to create the plurality of weakened paths **160**. As an example of external energy being used, e.g., laser (heat) energy may be used to locally disrupt the semicrystalline nature of the polymer forming the drape member **134** to impart a localized physical weakness. The localized physical weakness forms the plurality of weakened paths **160** that form the plurality of non-leaking tear paths **140**. Lasers may also be used to advance crosslinking or degradation (for example by the activation of materials such as dyes in the polymer) to initiate controlled lines of physical weakness in the drape member **134**. All of the above would need to either reduce locally the material thickness to create a weakness, or in some other way cause a polymeric weakness which may be exploited during the tear along the grain of the material of the drape member **134**.

As another approach still, portions of the drape member **134** between the locations of the plurality of weakened paths **160** may be fortified such that the plurality of weakened paths **160** are weak by comparison to the other portions. For example, a plurality of a fibers may be added to the drape or a strength-inducing coating may be added between the desired locations for the plurality of weakened paths **160**.

In creating the plurality of non-leaking tear paths **140**, it is desirable to form the adjustable covering **106** so that the adjustable covering **106** will not leak when in use. Thus, for example, straight-through perforations in the drape member **134** would not be satisfactory because the perforations would allow leaking by the adjustable covering **106** when reduced pressure was applied.

Perforations may, however, be used in another embodiment. For example, as shown primarily in FIGS. **6** and **7**, the drape member **134** may be formed with a first drape layer **174** and a second drape layer **176**. The first drape layer **174** has a first side **178** and a second, patient-facing side **180**. The second drape layer **176** has a first side **182** and a second, patient-facing side **184**. The second, patient-facing side **180** is adjacent to the first side **182** of the second drape layer **176**. The first drape layer **174** has a first perforated path **186** having a center line **188**. The first perforated path **186** may be formed with micro-perforations that weaken the first drape layer **174** and facilitate tearing. The second drape layer **176** has a second perforated path **190** with a center line **192**. The second perforated path **190** may also be formed with micro-perforations, which weaken the second drape layer **176** and facilitate tearing. The center line **188** of the first perforation path is displaced, or misregistered, from the center line **192** of the second perforation path **190** by a distance **194**. Distance **194** may be less than a few millimeters.

An area of misregistration bounded by the first perforated path **186** and the second perforated path **190** defines a tear path of the plurality of non-leaking tear paths **140**. At the same time, the misregistration allows the first and second perforation paths **186**, **190** to be sealed when not in use by the second and first drape layers **176**, **174** and to thereby avoid leaking. FIG. **7** shows the first and second drape layers **174**, **176** after the first support layer **135** and the releaseable backing layer **137** have been removed and the first perforation path **186** and the second perforation path **190** torn.

To adjust the size of the adjustable covering **106**, according to one illustrative embodiment, the desired tear path of the plurality of non-leaking tear paths **140** is selected to allow the remaining portion of the adjustable covering **106**

to be the desired size. Two portions of the tear starter of the first plurality of tear starters **150** aligning with the selected tear path desired are pulled away from each other to initiate a tear along the selected non-leaking tear path. Thus, for example, as shown in FIG. **2**, the first tear starter **152** is shown being pulled in direction **196** and **198** to start the tear along the first non-leaking tear path **142**. The tear causes an associated weakened path of the plurality of weakened paths **160** to separate. The adjustable covering **106** is thereby sized.

In another illustrative embodiment, the drape member **134** may be formed with different segments having different drape grains and non-leaking tear paths may be formed parallel to the drape grains in each segment to provide a drape that may be torn in different directions. This would allow, for example, the adjustable covering **106** to be modified in at least two different directions—longitudinal and lateral directions.

Although the present invention and its advantages have been disclosed in the context of certain illustrative, non-limiting embodiments, it should be understood that various changes, substitutions, permutations, and alterations can be made without departing from the scope of the invention as defined by the appended claims. It will be appreciated that any feature that is described in connection to any one embodiment may also be applicable to any other embodiment.

It will be understood that the benefits and advantages described above may relate to one embodiment or may relate to several embodiments. It will further be understood that reference to ‘an’ item refers to one or more of those items.

The steps of the methods described herein may be carried out in any suitable order, or simultaneously where appropriate.

Where appropriate, aspects of any of the examples described above may be combined with aspects of any of the other examples described to form further examples having comparable or different properties and addressing the same or different problems.

It will be understood that the above description of preferred embodiments is given by way of example only and that various modifications may be made by those skilled in the art. The above specification, examples and data provide a complete description of the structure and use of exemplary embodiments of the invention. Although various embodiments of the invention have been described above with a certain degree of particularity, or with reference to one or more individual embodiments, those skilled in the art could make numerous alterations to the disclosed embodiments without departing from the scope of the claims.

We claim:

1. A reduced-pressure treatment system for treating a tissue site, the system comprising:
  - a manifold adapted to be placed proximate to the tissue site;
  - an adjustable covering adapted to be placed adjacent to the tissue site and to form a fluid seal to a portion of an epidermis adjacent the tissue site, the adjustable covering having:
    - a plurality of micro-ridges comprising areas of local stretching, the plurality of micro-ridges forming an area of maximum curvature and a thickness  $t_1$  that is less than a thickness  $t_2$  of adjacent portions of the adjustable covering and further forming non-leaking tear paths on an initiation edge of the adjustable covering, and

9

a plurality of tear starters aligned with the plurality of micro-ridges, the plurality of tear starters adapted to facilitate the initiation of a tear along a respective micro-ridge;

a reduced-pressure interface adapted to be coupled to the adjustable covering; and

a reduced-pressure source adapted to be fluidly coupled to the reduced-pressure interface.

2. The system of claim 1, further comprising a backing layer releasably coupled to a second side of the adjustable covering and wherein the adjustable covering and the backing layer have a grain in a same direction.

3. The system of claim 1, further comprising a support layer releasably coupled to a first side of the adjustable covering and wherein the adjustable covering and the support layer have a grain in a same direction.

4. The system of claim 1, further comprising:

a backing layer releasably coupled to a first side of the adjustable covering;

a support layer releasably coupled to a second side of the adjustable covering; and

wherein the adjustable covering, the backing layer and the support layer have a grain in a same direction.

5. The system of claim 1, wherein the plurality of micro-ridges comprises a first plurality of micro-ridges, the plurality of tear starters comprises a first plurality of tear starters, and the initiation edge comprises a first initiation edge, the adjustable covering further comprising:

a second plurality of micro-ridges formed on a second initiation edge;

a second plurality of tear starters aligned with one tear path of the second plurality of micro-ridges, and wherein each of the second plurality of tear starters is adapted to facilitate the initiation of a tear along a respective one of the second plurality of micro-ridges.

6. The system of claim 1, wherein the plurality of micro-ridges are linear.

7. The system of claim 1, wherein the plurality of tear starters comprises a backing layer that extends beyond a peripheral edge of the adjustable covering and has perforations substantially aligned with the plurality of micro-ridges that facilitate initiation of tears in the backing layer.

8. The system of claim 1, wherein the plurality of micro-ridges comprises a first plurality of micro-ridges, the plurality of tear starters comprises a first plurality of tear starters, and the initiation edge comprises a first initiation edge, the adjustable covering further comprising:

a backing layer releasably coupled to a first side of the adjustable covering;

a support layer releasably coupled to a second side of the adjustable covering;

wherein the adjustable covering, the backing layer and the support layer have a grain in a same direction;

a second plurality of micro-ridges formed on a second initiation edge;

a second plurality of tear starters aligned with one tear path of the second plurality of micro-ridges, and wherein each of the second plurality of tear starters is adapted to facilitate the initiation of a tear along a respective one of the second plurality of micro-ridges; and

wherein the micro-ridges comprise an area of local stretching.

9. An adjustable covering for use with a reduced-pressure treatment system, the adjustable covering comprising:

a drape member;

a plurality of micro-ridges comprising areas of local stretching, the plurality of micro-ridges forming an area

10

of maximum curvature and a thickness  $t_1$  that is less than a thickness  $t_2$  of adjacent portions of the adjustable covering and further forming non-leaking tear paths on an initiation edge of the drape member; and

a plurality of tear starters aligned with the plurality of micro-ridges, the plurality of tear starters adapted to facilitate the initiation of a tear along a respective micro-ridge.

10. The adjustable covering of claim 9, further comprising a backing layer releasably coupled to a second side of the drape member and wherein the drape member and the backing layer have a grain in a same direction.

11. The adjustable covering of claim 9, further comprising a support layer releasably coupled to a first side of the drape member and wherein the drape member and the support layer have a grain in a same direction.

12. The adjustable covering of claim 9, further comprising:

a backing layer releasably coupled to a first side of the drape member;

a support layer releasably coupled to a second side of the drape member; and

wherein the drape member, the backing layer and the support layer have a grain in a same direction.

13. The adjustable covering of claim 9, wherein the plurality of micro-ridges comprises a first plurality of micro-ridges, the plurality of tear starters comprises a first plurality of tear starters, and the initiation edge comprises a first initiation edge, the adjustable covering further comprising:

a second plurality of micro-ridges formed on a second initiation edge;

a second plurality of tear starters aligned with one tear path of the second plurality of micro-ridges, and wherein each of the second plurality of tear starters is adapted to facilitate the initiation of a tear along a respective one of the second plurality of micro-ridges.

14. The adjustable covering of claim 9, wherein the plurality of micro-ridges are linear.

15. The adjustable covering of claim 9, wherein the plurality of tear starters comprises a backing layer that extends beyond a peripheral edge of the drape member and has perforations substantially aligned with the plurality of micro-ridges that facilitate initiation of tears in the backing layer.

16. The adjustable covering of claim 9, wherein the plurality of micro-ridges comprises a first plurality of micro-ridges, the plurality of tear starters comprises a first plurality of tear starters, and the initiation edge comprises a first initiation edge, the adjustable covering further comprising:

a backing layer releasably coupled to a first side of the drape member;

a support layer releasably coupled to a second side of the drape member;

wherein the drape member, the backing layer and the support layer have a grain in a same direction;

a second plurality of micro-ridges formed on a second initiation edge;

a second plurality of tear starters aligned with one tear path of the second plurality of micro-ridges, and wherein each of the second plurality of tear starters is adapted to facilitate the initiation of a tear along a respective one of the second plurality of micro-ridges; and

wherein the micro-ridges comprise an area of local stretching.