



US010131066B2

(12) **United States Patent**
Turover et al.

(10) **Patent No.:** **US 10,131,066 B2**
(45) **Date of Patent:** **Nov. 20, 2018**

(54) **CUTTING APPARATUS, SYSTEM AND METHOD**

(71) Applicant: **Crave Products, Inc.**, Palatine, IL (US)

(72) Inventors: **David Turover**, Chicago, IL (US);
Craig Wenger, Chicago, IL (US)

(73) Assignee: **Crave Products, Inc.**, Palatine, IL (US)

(*) Notice: Subject to any disclaimer, the term of this patent is extended or adjusted under 35 U.S.C. 154(b) by 283 days.

(21) Appl. No.: **15/014,632**

(22) Filed: **Feb. 3, 2016**

(65) **Prior Publication Data**

US 2017/0217036 A1 Aug. 3, 2017

(51) **Int. Cl.**
B26B 29/06 (2006.01)

(52) **U.S. Cl.**
CPC **B26B 29/063** (2013.01)

(58) **Field of Classification Search**
CPC B26B 29/063; B26B 27/002; A47J 25/00;
A47J 17/04; B26D 3/26; B26D 7/2614;
B26D 3/24; A21C 15/04
USPC 83/13; 30/302, 123.6, 114, 123.5, 123.7,
30/299, 337, 124, 296.1; 99/537, 541,
99/584, 506, 509, 544, 554, 540;
D7/672-676

See application file for complete search history.

(56) **References Cited**

U.S. PATENT DOCUMENTS

1,703,154 A 2/1929 Lanzkorn
1,764,235 A 6/1930 Wilmking

2,089,980 A	8/1937	Owen	
2,108,992 A	2/1938	Obenshain	
2,166,624 A *	7/1939	Cohn	B26D 1/553
			83/466.1
2,487,234 A	11/1948	Gore	
3,075,565 A	1/1963	Weaver et al.	
3,132,678 A	5/1964	Steketee	
3,292,257 A *	12/1966	Popeil	A23N 15/04
			30/121.5
3,452,795 A	7/1969	Davies	
4,165,855 A *	8/1979	Mason, Jr.	A47G 19/00
			249/102
4,580,343 A	4/1986	Bell, Jr.	
4,730,395 A *	3/1988	Blessing, Sr.	B23B 51/0426
			30/360
D298,199 S *	10/1988	Finsilver	D7/538
4,948,106 A	8/1990	Popeil et al.	
4,959,903 A *	10/1990	Daoust	A47J 17/04
			30/114
D335,795 S *	5/1993	Conti	D7/359
5,499,578 A	3/1996	Payne	
5,937,525 A *	8/1999	Chan	A47J 25/00
			30/114
8,272,631 B2	9/2012	Gannon	

(Continued)

Primary Examiner — Ghassem Alie

(74) *Attorney, Agent, or Firm* — Scherrer Patent & Trademark Law, P.C.; Stephen T. Scherrer; Monique A. Morneault

(57) **ABSTRACT**

An improved apparatus, system and method for preparing food items, is described. Specifically, the present disclosure is directed to an improved cutting apparatus for cutting and slicing food items. The cutting apparatus includes modular components that provide containment space for the food items, as well as cutting surfaces for receiving, cutting and slicing the food items. The present cutting apparatus provides an efficient, step-saving system and method for cutting, slicing, mixing and preparing food items.

13 Claims, 13 Drawing Sheets

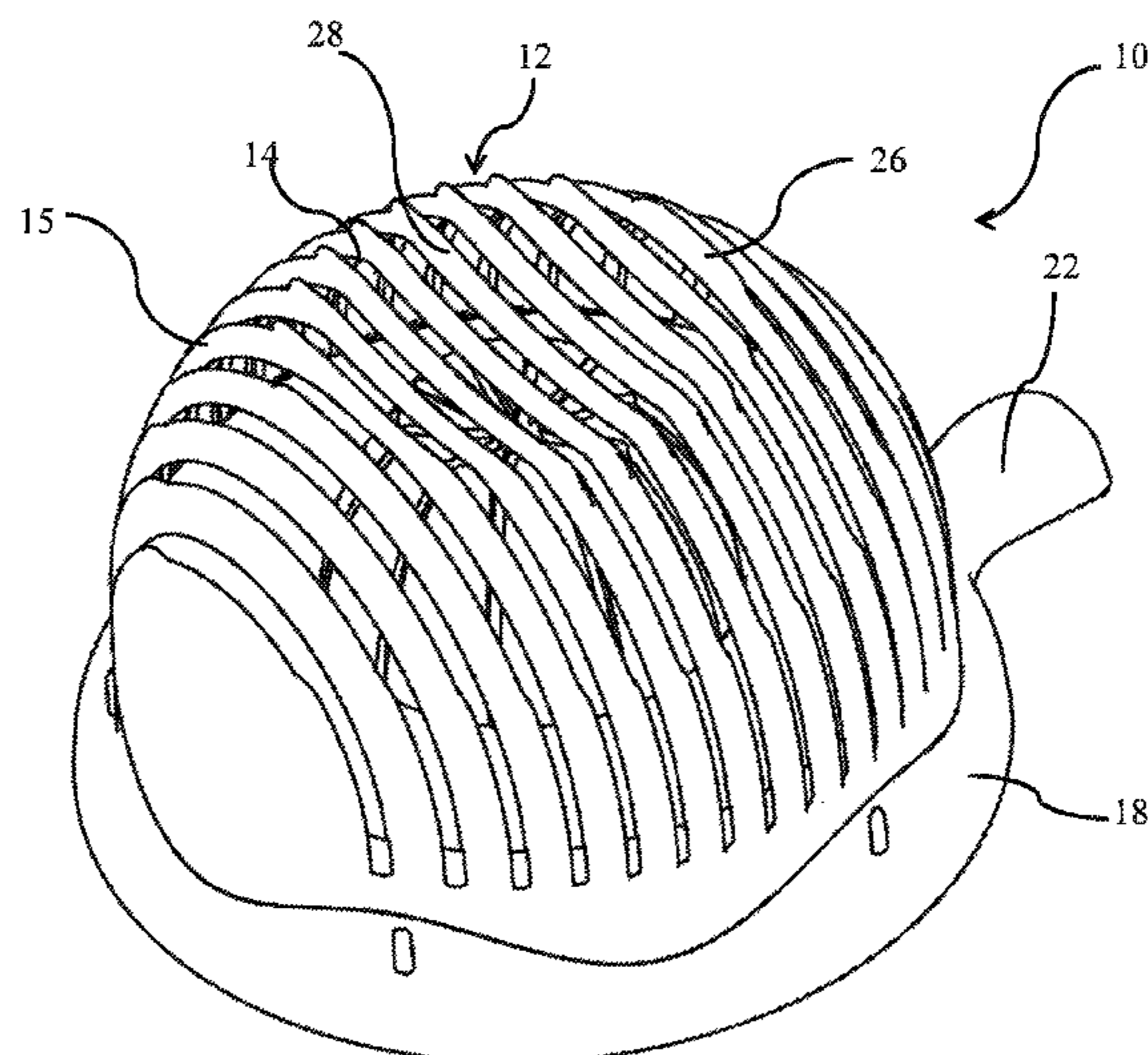

(56)

References Cited

U.S. PATENT DOCUMENTS

8,448,552	B2	5/2013	Hoffman	
9,259,847	B2 *	2/2016	White, III B26D 3/24
D769,054	S *	10/2016	Lee D7/352
D776,500	S *	1/2017	Verbrugge D7/693
2004/0016131	A1	1/2004	Hayashi	
2008/0168660	A1 *	7/2008	Chiu A47J 19/02 30/114
2009/0282990	A1 *	11/2009	Farnum B26B 3/04 99/537

* cited by examiner

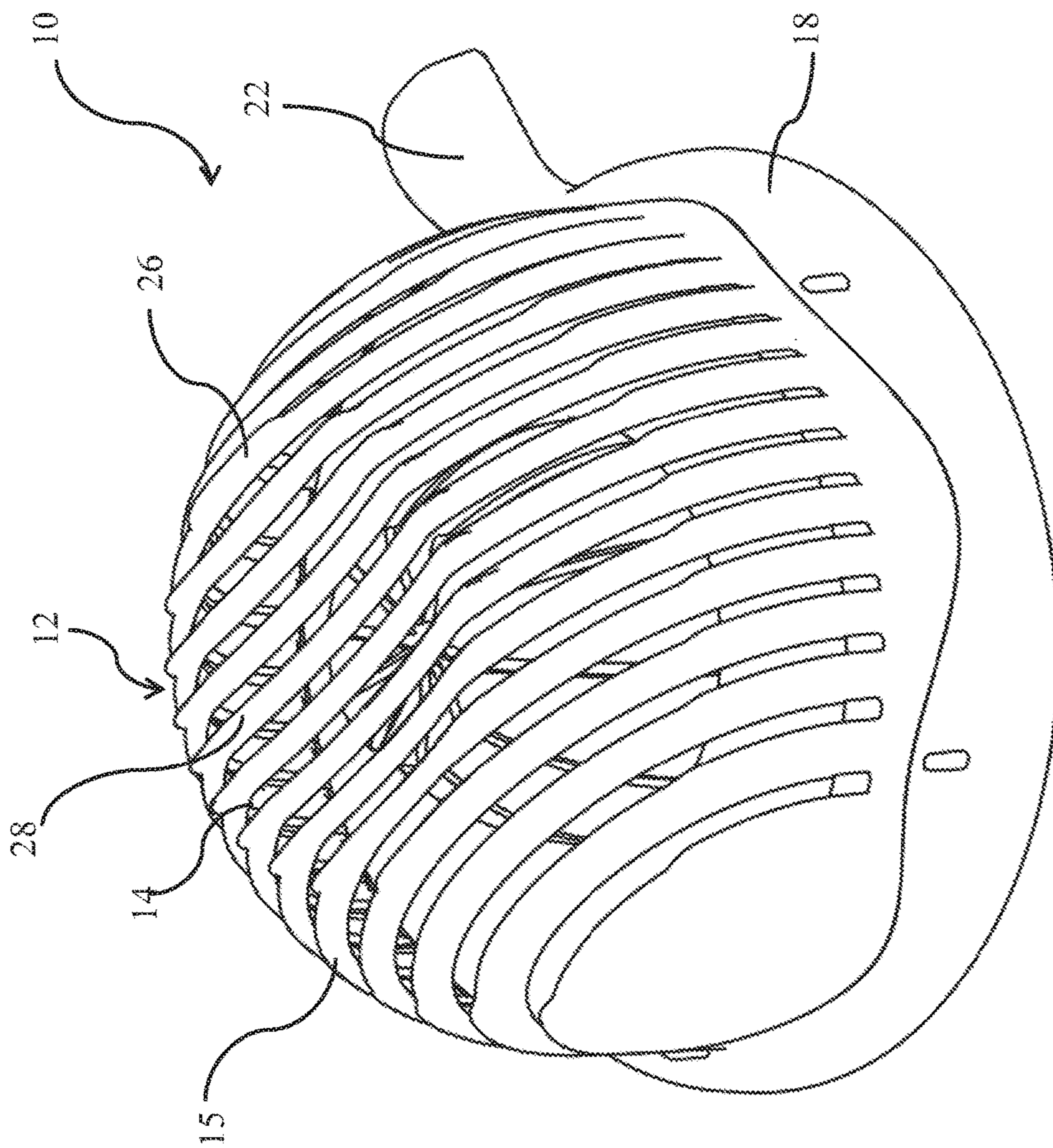

FIG. 1

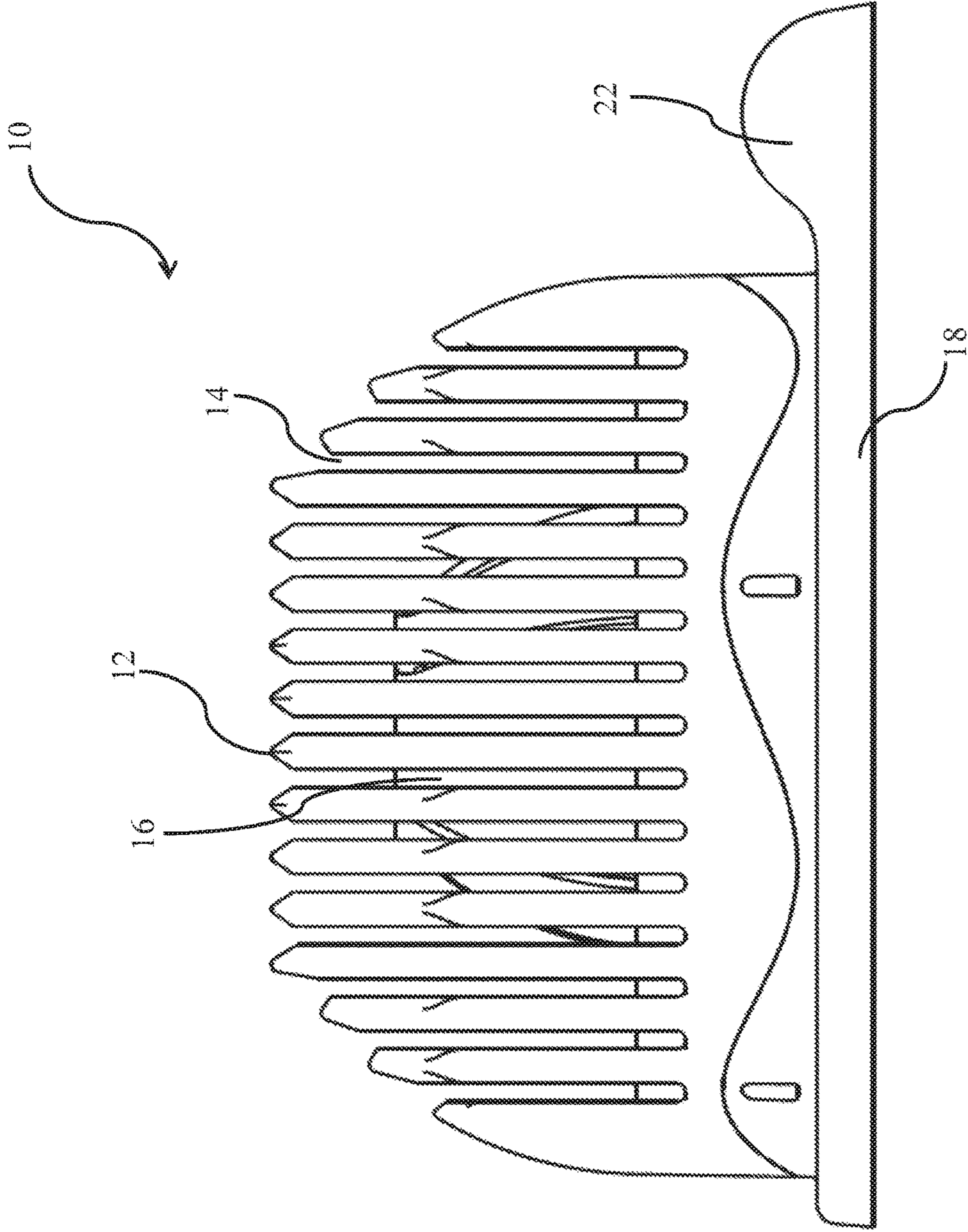

FIG. 2

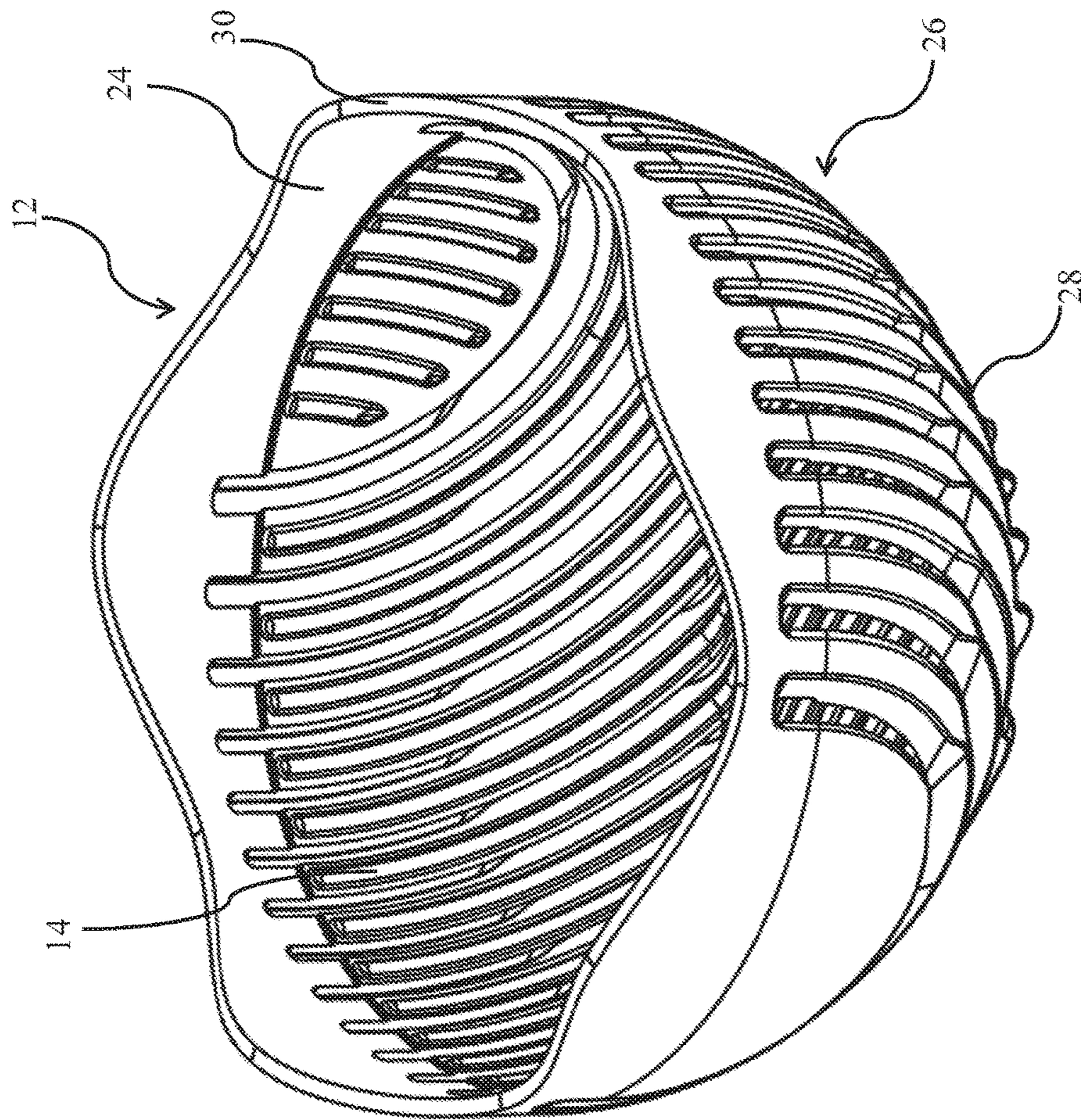

FIG. 3

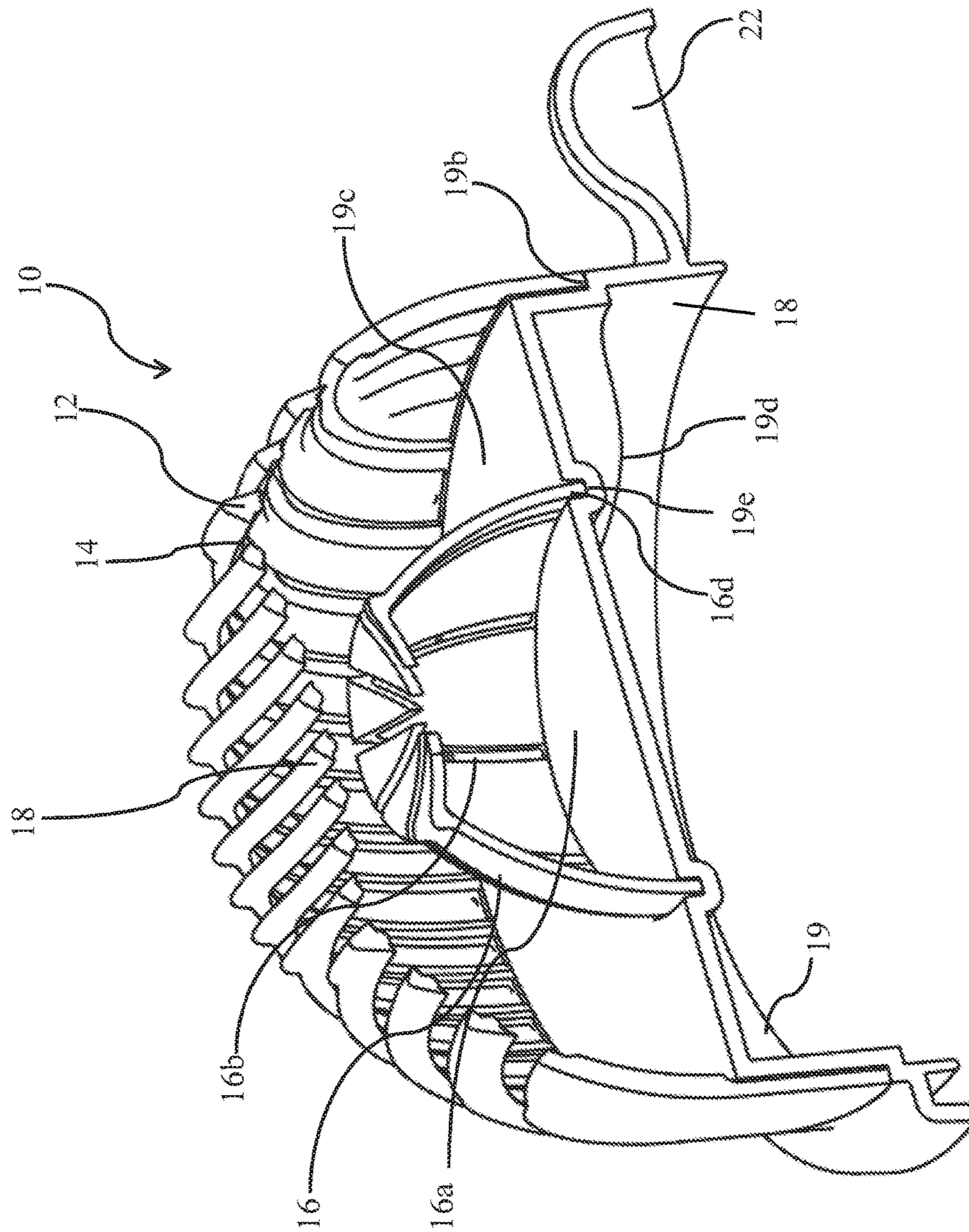

FIG. 4

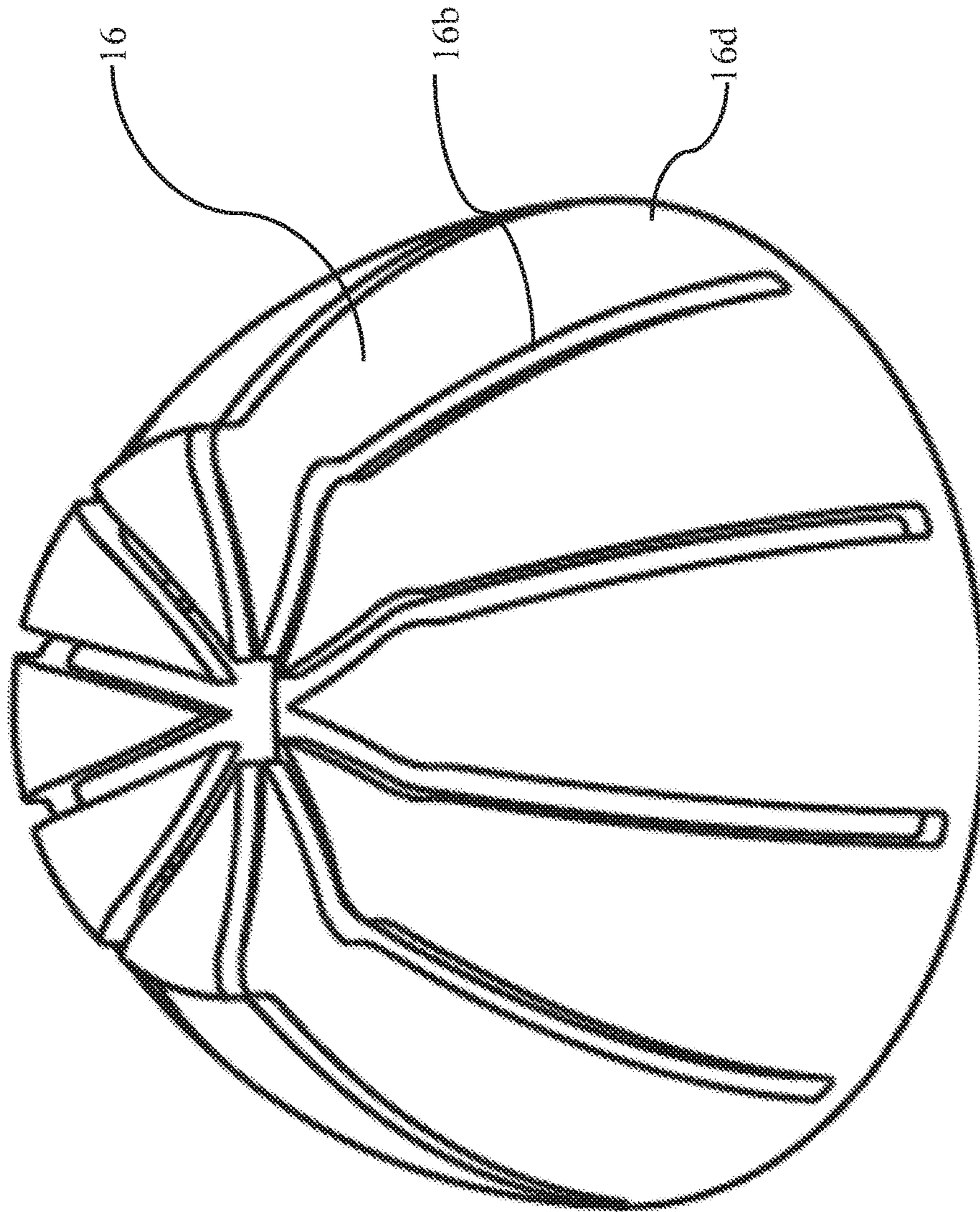

FIG. 5

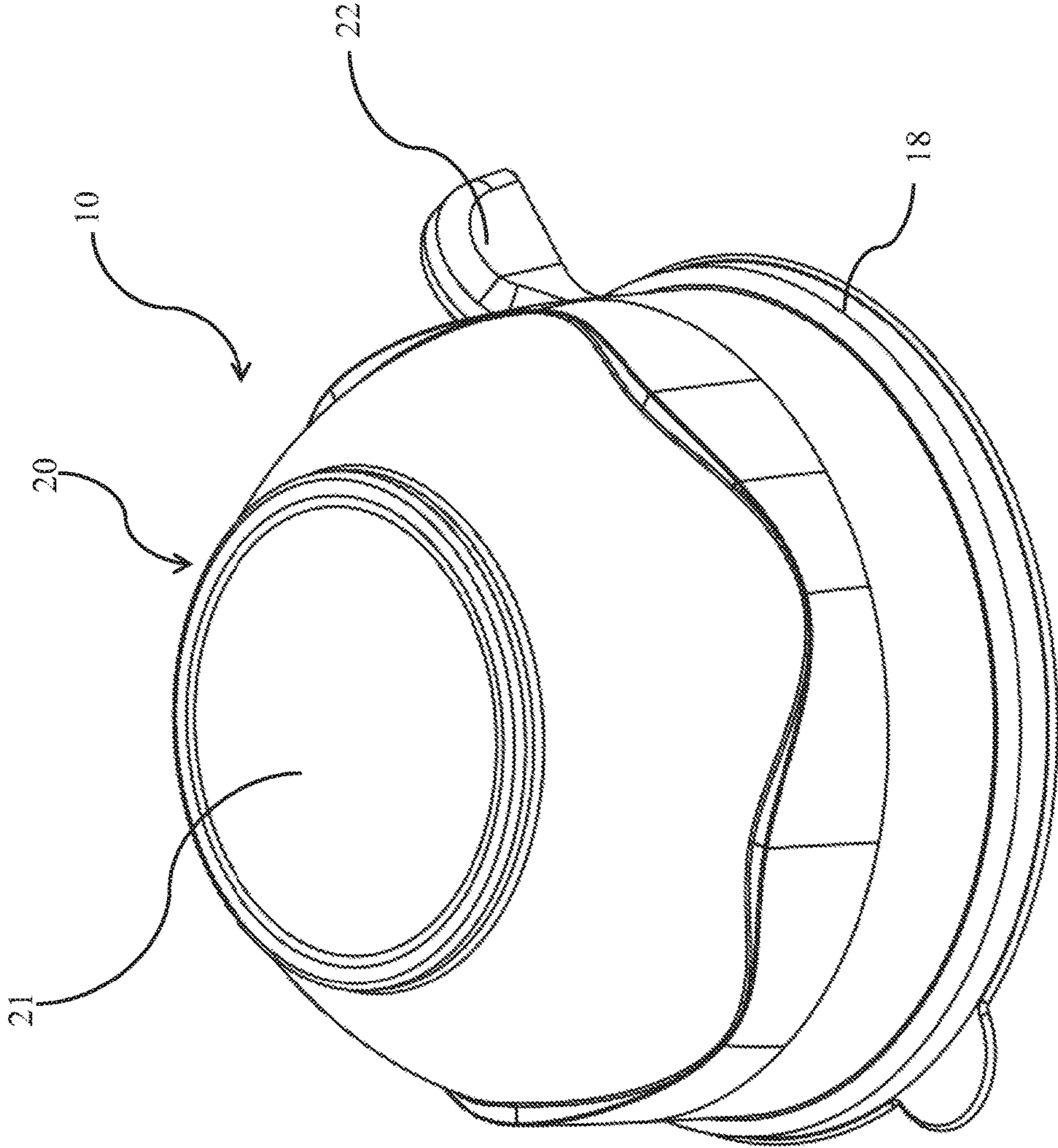

FIG. 6

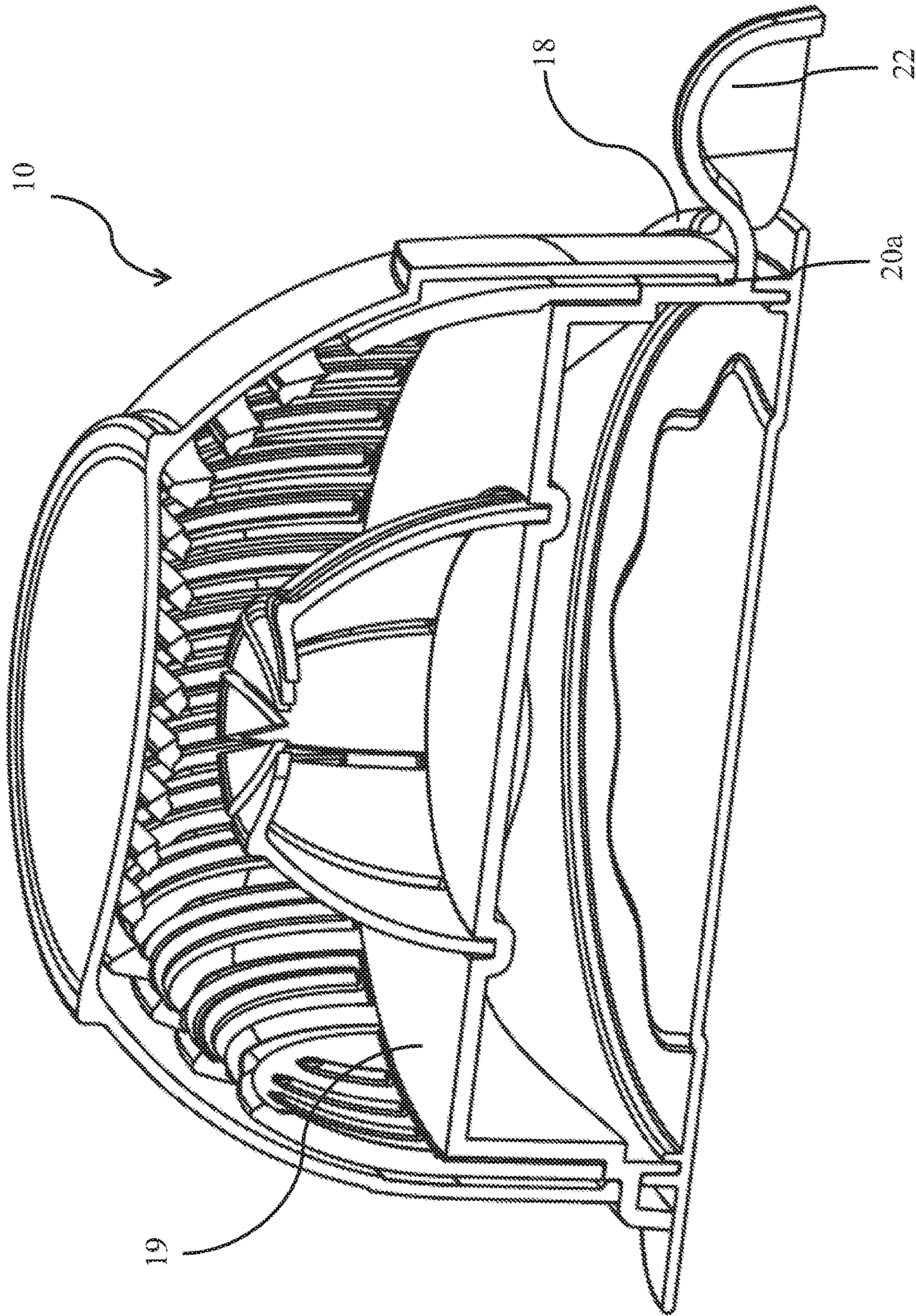

FIG. 7

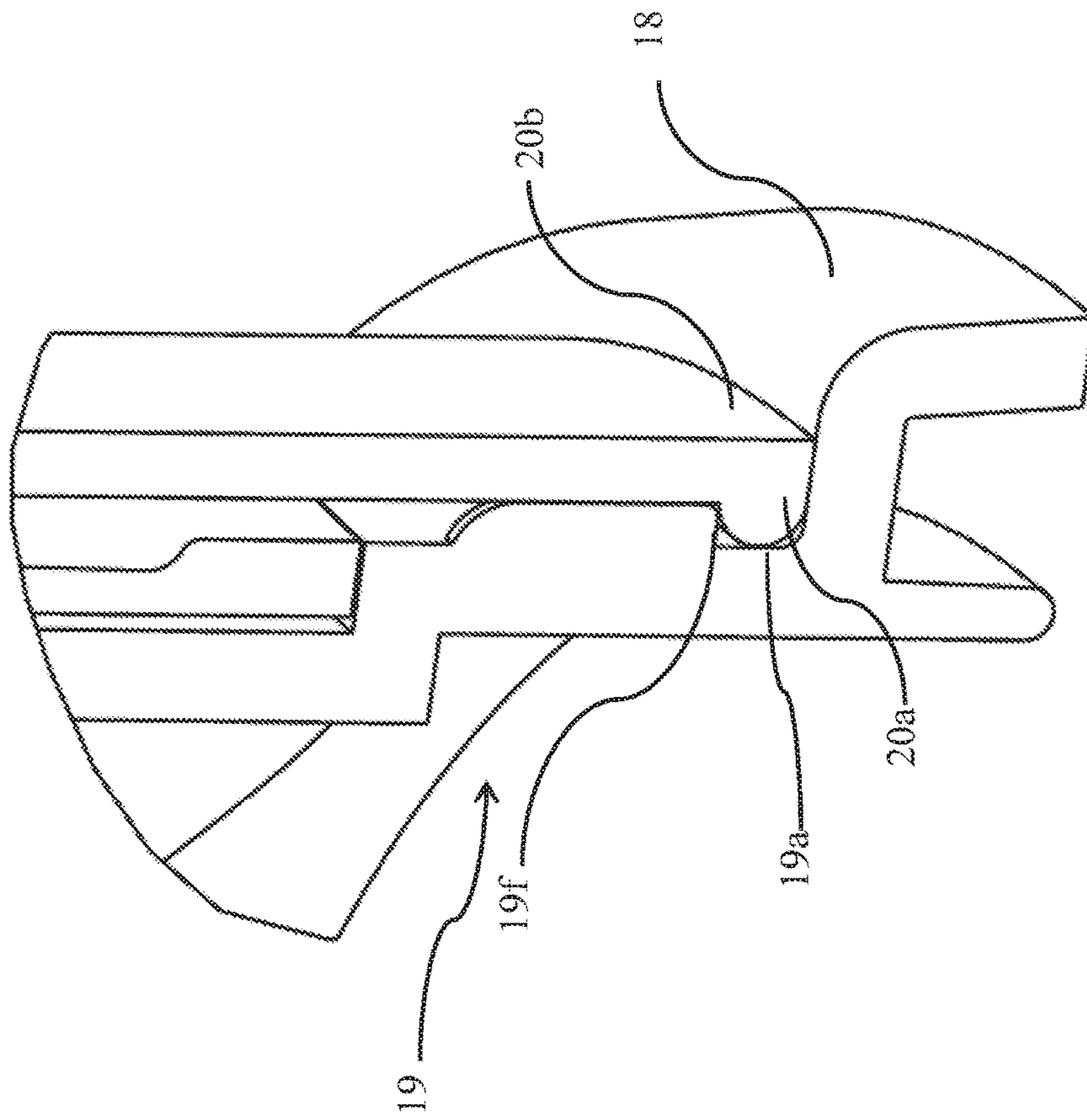

FIG. 8

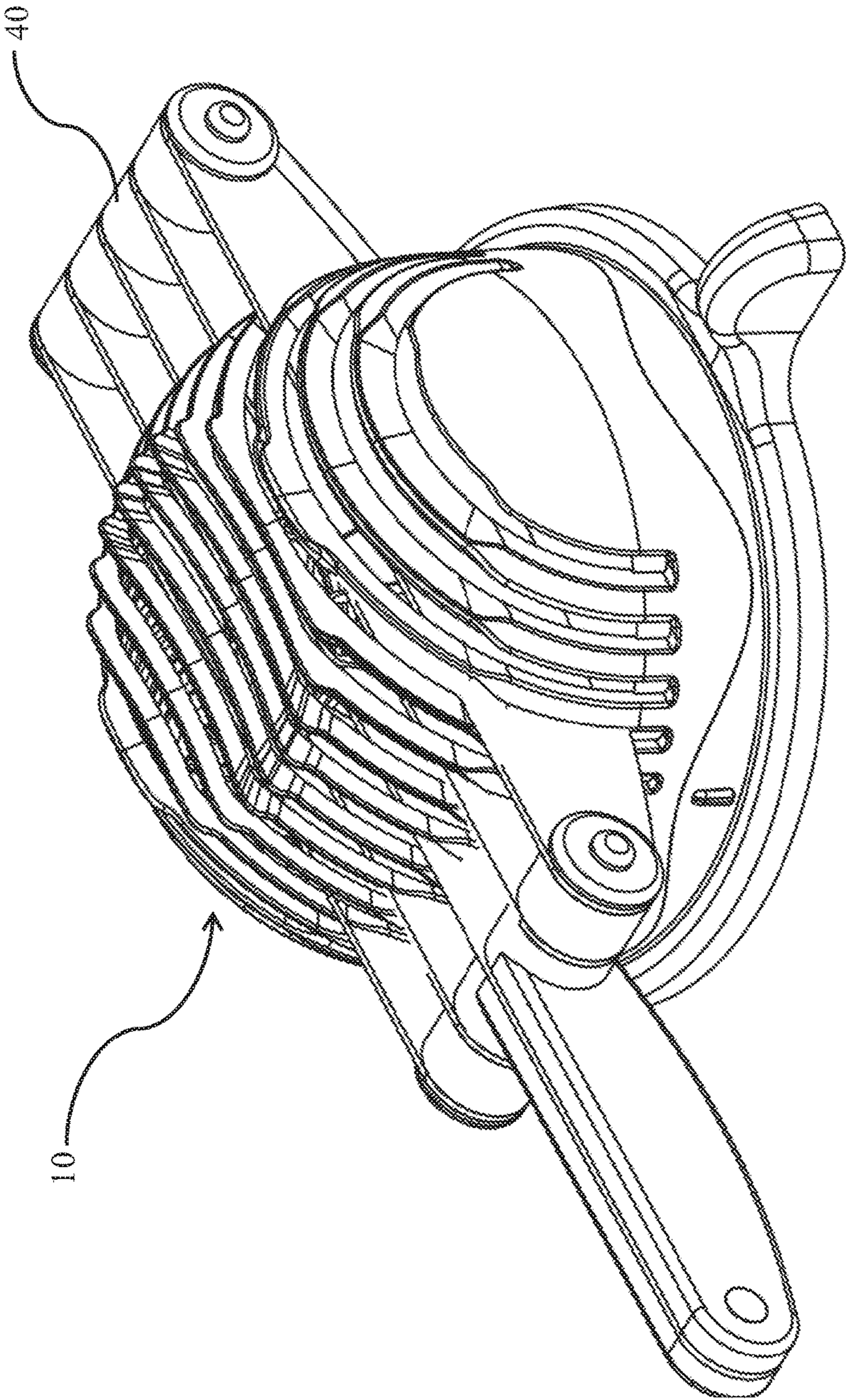

FIG. 9

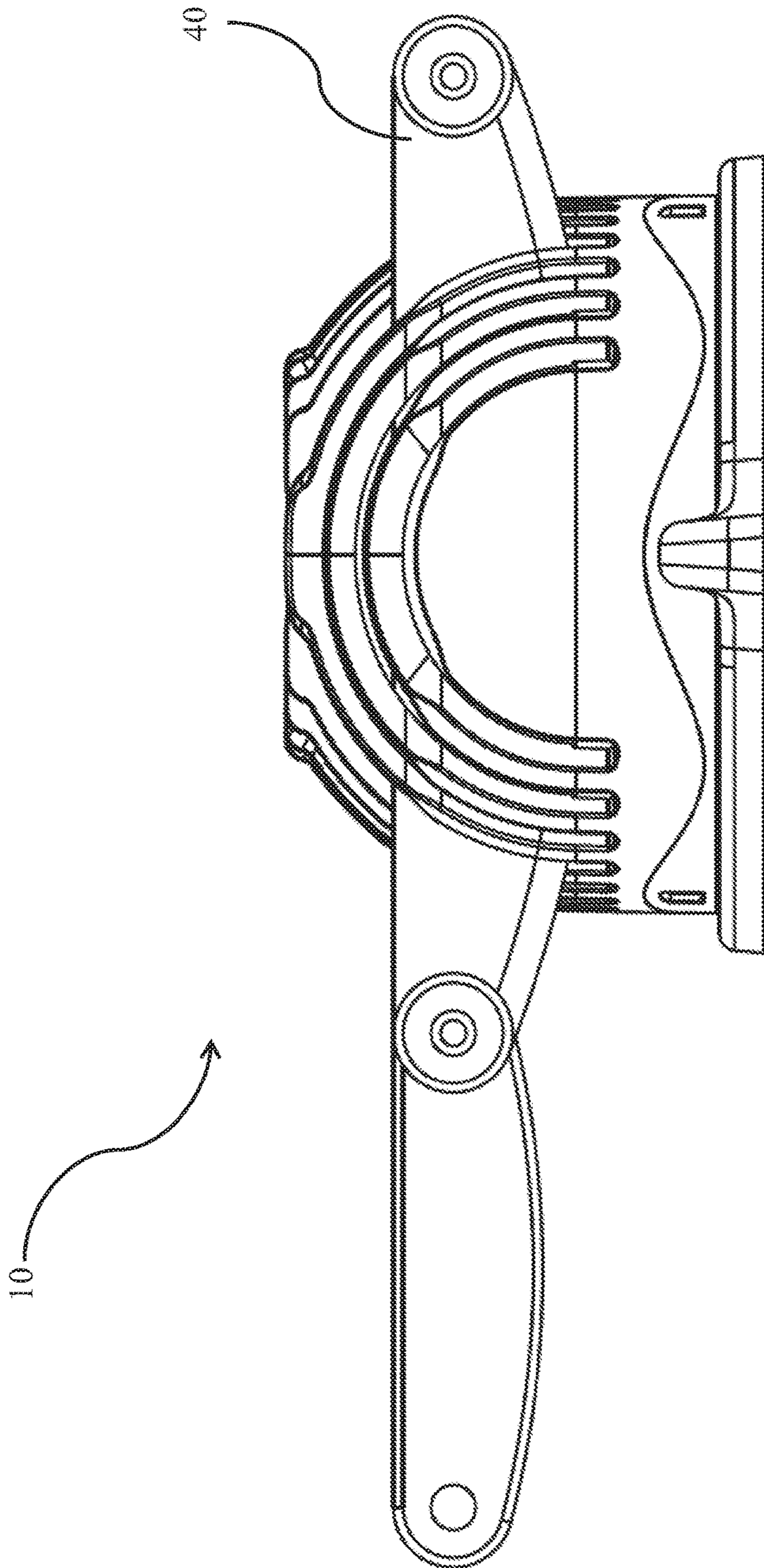

FIG. 10

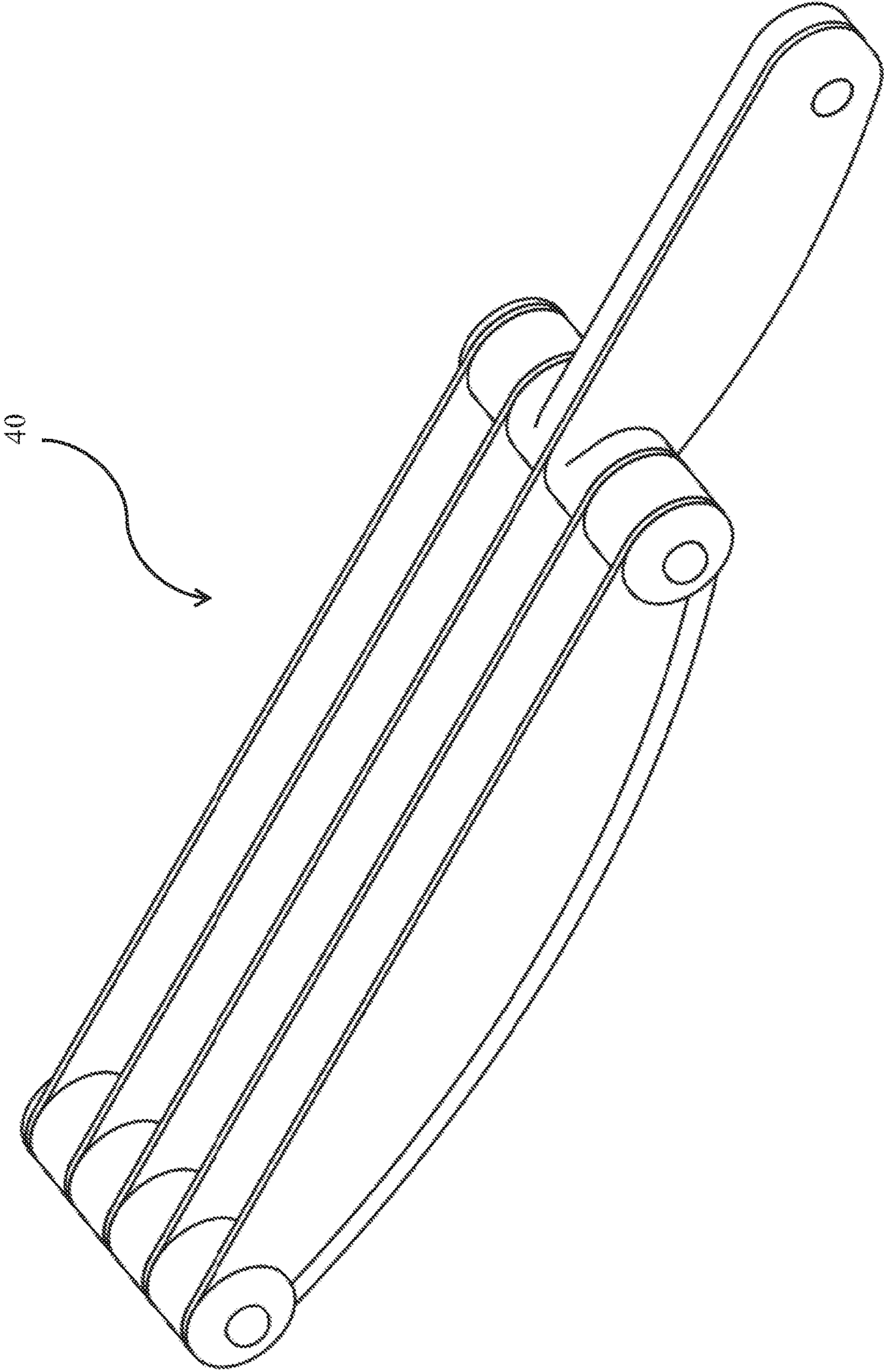

FIG. 11

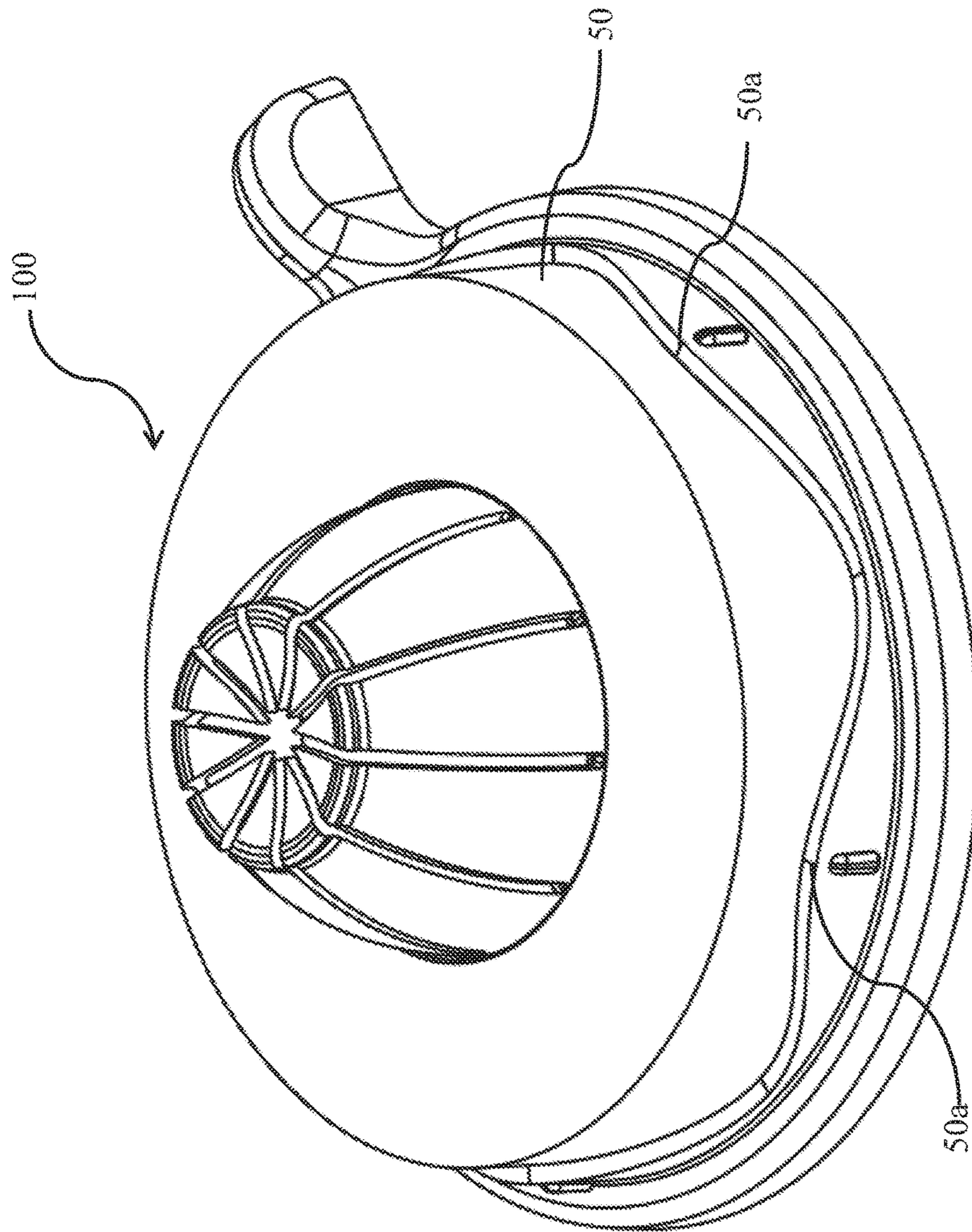

FIG. 12

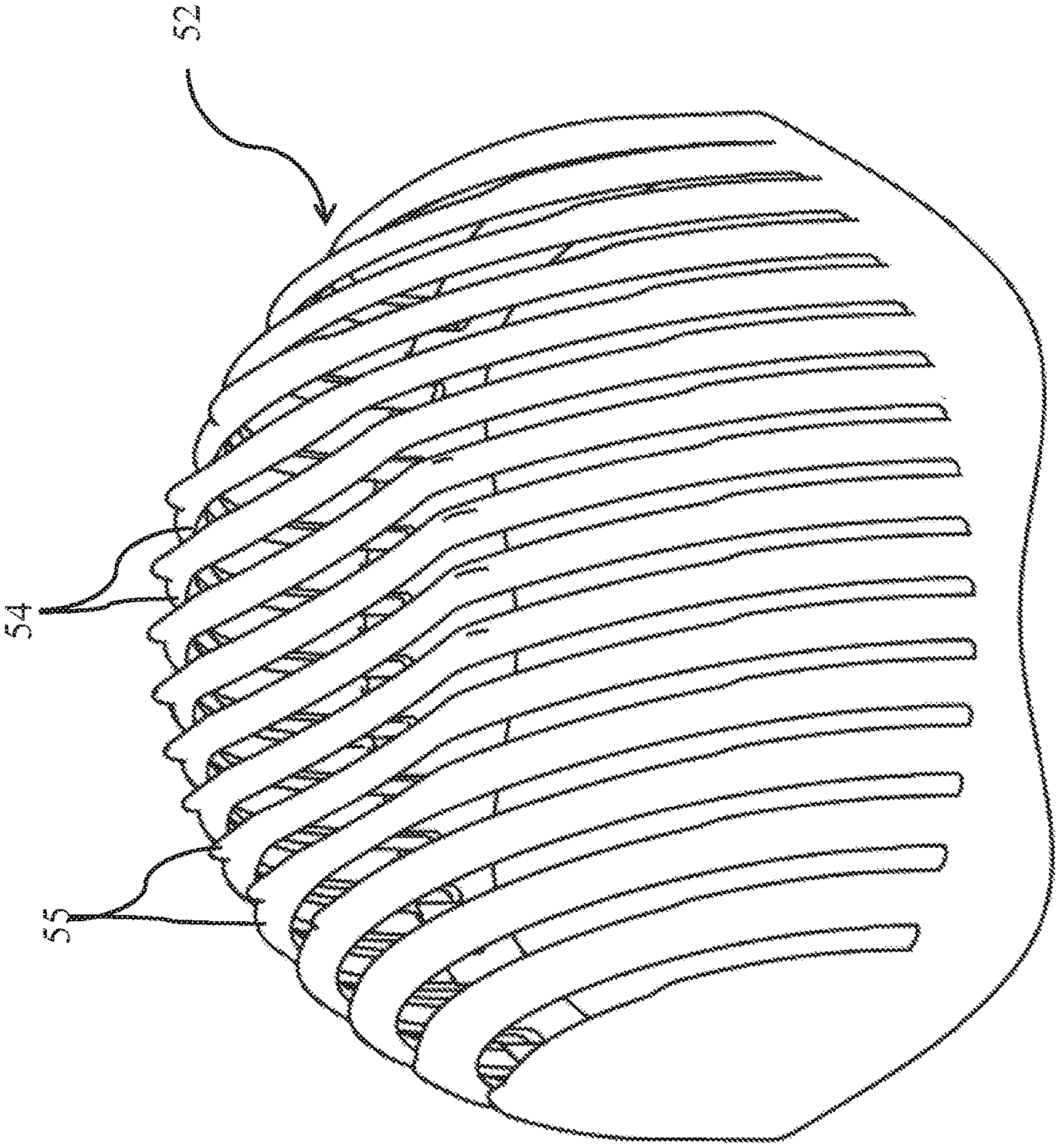

FIG. 13

CUTTING APPARATUS, SYSTEM AND METHOD

TECHNICAL FIELD

The present invention relates to cutting apparatuses, systems and methods for slicing, cutting and combining food items. In particular, the present disclosure relates to a cutting apparatus having interlocking, modular components that combine to form a self-contained unit for receiving, cutting and slicing food items, without the need for special knife skills. A system and method for cutting food items requiring fewer preparation steps is also provided.

BACKGROUND

It is, of course, generally known to cut up food items, such as vegetables, fruits and meats using a knife. In order to cut vegetables, meats and other items into smaller pieces, it is necessary to put the knife in several cross directions, which can require some degree of knife skills for even cutting and slicing. Additionally, as the items get smaller during cutting, it can become more difficult to hold the items by hand in order to complete the cutting process, which may lead to inadvertent injury.

Cutting and slicing food items can also be tedious. Some items, such as onions, tend to be difficult to cut not only because of their layers, but also because of the chemical that is released during cutting, which is irritating to the eyes. Other items, such as tomatoes, peaches, nectarines can be soft and difficult to cut into uniform pieces. Finally, certain types of fruit, such as apples and oranges can likewise be difficult to cut into uniform pieces.

Preparing a salad typically includes cutting lettuce and other vegetables into bite size pieces using a cutting board. The cut items are then typically combined into a separate container for mixing and serving. It would be advantageous to combine the steps of making a salad, including cutting the vegetables and combining them into a serving bowl, in fewer steps.

Therefore, it would be advantageous to provide a cutting apparatus, system and method that provides a modular unit that combines cutting, serving and storage of the cut food items.

It would be further advantageous to provide a cutting apparatus, system and method for cutting and combining food items having a combination of components that are easily nested together for use and storage.

It would also be advantageous to provide a cutting apparatus, system and method for cutting and/or slicing food items without requiring the user to directly handle the food item while it is being cut.

Additionally, it would be advantageous to provide a cutting apparatus, system and method for cutting and slicing food items into uniform pieces without requiring special knife skills.

It would be further advantageous to provide a cutting apparatus, system and method for cutting and slicing food items without the need to place hands and fingers in proximity of the cutting blades.

It would be advantageous to provide a cutting apparatus, system and method that saves process steps during food preparation.

It would be advantageous to provide a cutting apparatus, system and method that allows for the cutting and slicing of

foods, retaining water, fluids and/or juices that are normally lost during the cutting process, providing for healthier and tastier foods.

It would be further advantageous to provide a cutting apparatus, system and method that allows the cutting and slicing of food allowing for easy rotation of the cutting surface. Moreover, it would be advantageous to provide a cutting apparatus, system and method that allows a cutting template to be disposed over the food items to be cut, and by rotation of the cutting surface provides for alternate positioning of the food items on the cutting surface and beneath the cutting template. Further, it would be advantageous to provide a cutting apparatus, system and method that provides a raised cutting surface, such that when a cutting template is placed over the food items to be cut, and the cutting surface is rotated therebeneath, the food items remain on the cutting surface without being subject to falling out of the apparatus.

These and other aspects of the invention will become readily apparent from the detailed description, which follows.

SUMMARY

The present disclosure relates to an improved apparatus, system and method for preparing food items. Specifically, the present disclosure is directed to an improved cutting apparatus for cutting and slicing food items. The cutting apparatus includes modular components that provide containment space for the food items, as well as cutting surfaces for receiving, cutting and slicing the food items. Additionally, the present cutting apparatus can serve as a mixing and serving device. Thus, the present cutting apparatus provides an efficient, step-saving system and method for cutting, slicing, mixing and preparing food items.

To this end, in an embodiment of the present invention, a cutting apparatus is described. The cutting apparatus comprises a first cutting body having a bowl shape and an outer rim, wherein a circumference of the rim forms a wave pattern, a plurality of slots passing through the first cutting body, and a base releasably attached to the outer rim of the first cutting body, wherein the base is a cutting surface.

In another embodiment, a device for receiving, cutting, mixing, and storing food items is described. The device comprises a first cutting body having a generally semispherical shape forming an inner space and an outer rim having a wave pattern, a plurality of parallel slots covering an outer surface of the first cutting body, wherein the slots connect the outer surface of the body with the inner space, a base having a platform for receiving an item to be cut, wherein the first cutting body is releasably secured to the base, a second cutting body having a generally semispherical shape disposed within the inner space of the first cutting body, the second cutting body releasably secured to the base platform, a plurality of radially arranged slots intersecting at a top surface of the second cutting body, and, an outer body having a generally semispherical shape forming an inner space for receiving the first cutting body and second cutting body.

In yet another embodiment, a system for cutting food items is described. The system comprises a first cutting body having a bowl shape forming a semispherical inner space for receiving an item for cutting and a rim having a circumferential wave pattern, a plurality of slots disposed on the first cutting body wherein the slots connect an outer surface of the body with the inner, wherein the slots are adapted for receiving a cutting device, and, a base releasably attached to

3

the rim of the first cutting body, wherein the base further includes a platform for receiving an item to be cut and acts as a cutting surface.

In yet a further embodiment, a method for cutting and processing food items is disclosed. The method comprises the steps of providing a first cutting body having a semi-spherical inner space for receiving an item for cutting and a rim having a first wave pattern, wherein the body includes a plurality of slots passing through the first cutting body and connecting an outer surface of the body with the inner space, providing a base with a platform having an outer circumference including a second wave pattern, receiving an item to be cut on the platform, engaging the first wave pattern on the rim with the second wave pattern on the platform thereby securing the first cutting body to the base, passing a cutting device through the plurality of slots, and, cutting the item on the platform.

It is, therefore, an advantage and objective of the present disclosure to provide a cutting apparatus, system and method for preparing food items requiring fewer process steps.

Moreover, it is an advantage and objective of the present disclosure to provide a cutting apparatus, system and method for cutting and slicing food items into multiple uniform pieces without requiring special knife skills.

It is further an advantage and objective of the present disclosure to provide a cutting apparatus which creates a barrier between the fingers/hands of the user and the knife or cutting implement, as well as, the food items being cut.

Moreover, it is an advantage and objective of the present disclosure to provide a cutting apparatus, system and method that allows for the cutting and slicing of foods, retaining water, fluids and/or juices that are normally lost during the cutting process, providing for healthier and tastier foods.

It is a further advantage and objective of the present disclosure to provide a cutting apparatus, system and method that allows the cutting and slicing of food allowing for easy rotation of the cutting surface.

Moreover, it is a further advantage and objective of the present disclosure to provide a cutting apparatus, system and method that allows a cutting template to be disposed over the food items to be cut, and by rotation of the cutting surface provides for alternate positioning of the food items on the cutting surface and beneath the cutting template.

Further, it is an advantage and objective of the present disclosure to provide a cutting apparatus, system and method that provides a raised cutting surface, such that when a cutting template is placed over the food items to be cut, and the cutting surface is rotated therebeneath, the food items remain on the cutting surface without being subject to falling out of the apparatus.

Additional features and advantages of the present disclosure are described in, and will be apparent from, the detailed description of the presently preferred embodiments and from the drawings.

BRIEF DESCRIPTION OF THE DRAWINGS

The drawing figures depict one or more implementations in accord with the present concepts, by way of example only, not by way of limitations. In the figures, like reference numerals refer to the same or similar elements.

FIG. 1 illustrates a perspective view of a cutting apparatus of the present disclosure;

FIG. 2 illustrates a side view of the cutting apparatus of the present disclosure;

4

FIG. 3 illustrates a perspective view of a first cutting body of the cutting apparatus of the present disclosure;

FIG. 4 illustrates a cut-away view of the cutting apparatus of the present disclosure;

FIG. 5 illustrates a perspective view of a second cutting body of the cutting apparatus of the present disclosure;

FIG. 6 illustrates a perspective view of a cover on the cutting apparatus of the present disclosure;

FIG. 7 illustrates a second cut-away view of the cutting apparatus of the present disclosure;

FIG. 8 illustrates a close-up cut-away view of an engagement element for the cover of the cutting apparatus of the present disclosure;

FIG. 9 illustrates a perspective view of the cutting apparatus of the present disclosure in use with a cutting implement;

FIG. 10 illustrates a side view of the cutting apparatus of the present disclosure in use with a cutting implement;

FIG. 11 illustrates a perspective view of a cutting implement useful with the cutting apparatus of the present disclosure; and,

FIG. 12 illustrates another embodiment of a perspective view of a cutting apparatus of the present disclosure.

FIG. 13 illustrates a perspective view of a first cutting body in an alternate embodiment of the present disclosure.

DETAILED DESCRIPTION

The present invention relates to a cutting apparatus. More specifically, the present disclosure relates to a cutting apparatus having interlocking, modular components that combine to form a self-contained unit for receiving, cutting and slicing food items. Systems and methods for using the cutting apparatus are also provided.

Now referring to the figures, wherein like numerals refer to like parts, FIGS. 1-13 show several embodiments and components of the present cutting apparatus 10. FIGS. 1-4 illustrate an initial embodiment of the present cutting apparatus 10. The cutting apparatus 10 includes a first cutting body 12 having a semispherical or bowl shape. The first cutting body 12 further includes a plurality of slots 14 that receive and guide a cutting implement (not shown), which may have one blade or multiple blades on a single handle. The first cutting body 12 may have a plurality of ribs 15 between the plurality of slots 14 and dividing the plurality of slots from one another. The cutting apparatus 10 may also include a second cutting body 16, which can be sized so it is contained within the first cutting body 12, particularly when the apparatus is in a stored position. The second cutting body 16 also includes a plurality of slots. The first and second cutting bodies 12, 16 are used to cover the food items to be cut. The cutting apparatus further includes a base 18 having a platform 19 for engagement with the cutting bodies, and a cover 20.

Referring to FIG. 3, the first cutting body 12 is shown having a semispherical or dome-like shape, which forms an open inner space 24. An outer surface 26 of the first cutting body 12 further includes a flattened section 28 of any suitable shape or diameter, which is also clearly seen in FIGS. 1 and 2. When the first cutting body 12 is turned over to rest on the flattened section 28 as shown in FIG. 3, the body is prevented from rolling and can be used as a receiving and serving bowl. It should be understood that the first cutting body 12 can have any suitable shape, including round, oval, even square or rectangular.

The first cutting body 12 includes an opening rim 30 forming the outer circumference of the body. As shown in

5

FIG. 3, the outer circumference of the rim 30 has an uneven or wave pattern, so that if the body 12 was placed rim side on a flat surface, the shape of the rim would not permit the body to lay flat. The wave pattern of the rim 30 provides a unique shape that permits the first cutting body 12 to engage with and be secured to the base 18. Multiple variations of wave patterns or various wave lengths are useful in the different embodiments of the present apparatus. For example, the platform 19 of FIG. 1 has a wave pattern 19d with a longer wave length (the distance between the crest of the wave and the trough of the wave), while the platform 50 having the wave pattern 50a of the embodiment of the cutting apparatus 100 illustrated in FIG. 12, has a shorter wave length.

Referring to FIGS. 2 and 4, the apparatus 10 includes a base 18 with a platform 19. The platform 19 is adapted for receiving and securing both the first cutting body 12 and the second cutting body 16. The base 18 is shaped in a configuration to complement the overall shape of the first cutting body 12, whether the cutting body is round, oval, rectangular, or another suitable shape.

The base 18 further includes a handle 22. The handle 22, which is integrally formed with the base, is shown having a semi-circular profile. The shape of the handle 22 complements the overall shape of the apparatus 10 and makes the handle easier to grasp; however, it should be understood that the handle can have any suitable shape.

As shown in FIGS. 2 and 4, the base 18 includes an integrated raised platform 19. The platform 19 has a step configuration, with a first level 19a for receiving the cover 20, a second level 19b for receiving the first cutting body 12, and a third level 19c forming a cutting surface. As shown in FIG. 3, the rim of the cover 20 rests against the first level 19a of the platform and on the base 18, whereas, the first cutting body 12 rests on and against the second level 19b of the platform. Additionally, the second level 19b has a wave pattern 19d forming an outer circumference of the platform 19. Thus, the wave patterned rim 30 of the first cutting body 12 engages with the wave pattern 19d forming the outer circumference of the platform thereby securing the first cutting body 12 to the platform 19 and the base 18. The platform 19 additionally serves as a receiving and cutting surface (third level 19c) for the items placed within the first cutting body 12. Preferably, the platform 19 is disposed above the wave pattern 19d formed on the outer circumference of the platform 19.

As shown in the figures, the first cutting body 12 further includes a plurality of slots 14. The slots 14 are provided over the entire body and are generally evenly spaced (approximately 3.5 mm apart) from one another and positioned parallel to one another, passing through and covering the entire outer surface 26 of the first cutting body 12 from one side of the rim 30 to the other. The slots 14 can have any suitable width for receiving a cutting implement. The slots 14 are used for receiving and guiding a cutting implement, such as a knife blade to enter the inner space 24 of the first cutting body 12 for cutting the food item held within the cutting body. It should be understood that the overall dimension of the first cutting body, the width of the slots, and the distance between the slots are not limited to the present embodiment, but can be altered to accommodate different cutting implements, as well as the food items to be processed.

In an alternate embodiment of the present invention, FIG. 13 illustrates a first cutting body 52 having a plurality of evenly spaced, parallel slots 54 therein, in a similar configuration to the first cutting body 12, disclosed above. The

6

ribs 55 may be between the plurality of slots 54 and divide the plurality of slots 54 from each other. As illustrated in FIGS. 1-4, the plurality of ribs 15 may be flat. However, each of the plurality of ribs 55 may come together at a midpoint thereof in a peak or a point, having angled sides disposed downwardly to help guide a cutting implement to the food item contained therein without having to take time and effort to align the cutting implement with the slots 5. Moreover, the ribs 55, as shown in FIG. 13 and described above, may further help ensure that the cutting implement easily moves into one or more of the slots 54, preventing the cutting implement from slipping left or right, possibly causing injury. In other words, a user may place a cutting implement in alignment with one or more of the slots 54, and the peaked and angled ribs may guide the blade of the cutting implement to the food item contained therein.

In use, a food item may be placed on the third level 19c of the platform 19 of the base 18. The first cutting body 12 (or 52, as shown in FIG. 13) may be positioned on the platform 19 of the base 18, resting on the second level 19b thereof, having the wave pattern thereon. A cutting implement, such as a knife having a suitable blade length, may be disposed through one or more of the slots 14 (or 54) to cut the food item therein. Thus, the food item may be cut into two or more portions. Optionally, the handle 22 may be grasped by the user and the base 18 may be rotated, while the first cutting body may be held in place, thereby rotating the food item contained on the base 18. The cutting implement may be used to cut the food item one or more additional times through the slots 14 (or 54), but because the food item has been rotated, the cuts placed into the food items are cross-cuts to the cuts placed into the food item prior to rotation. The base 18 may be rotated a plurality of times to place several cross-cuts into the food items contained therein. This may be particularly preferable when cutting ingredients for a salad to create a chopped salad, for example. The wave pattern in the second level 19b may provide discrete positions for the first cutting body 12 to be placed for cutting of the food contained therein. Further, as illustrated in FIG. 3, the first cutting body 12 (or 52) may be inverted to be used as a bowl to contain the cut food item or items. Preferably, the second level 19b may be positioned above the wave pattern 19d such that an item placed and cut on the second level 19b may remain entirely contained within the cutting body 12 when the platform 19 and base 18 rotates therebeneath.

Referring to FIG. 5, the cutting apparatus 10 includes a second cutting body 16. The second cutting body 16 is generally smaller in size than the first cutting body 12, so that the second cutting body can be positioned within the inner space 24 of the first cutting body, providing a compact arrangement particularly when storing the cutting apparatus 10. The second cutting body 16 has a semispherical outer surface forming an inner space 16a for receiving an item to be cut (FIG. 4).

The second cutter body 16 also includes a plurality of radially arranged slots 16b intersecting and forming a top opening 16c of the second cutting body. The slots 16b and top opening 16c of the second body 16 receive and guide a knife blade into the inner space 16a of the body for contacting a food item held within the inner space 16a of the body. The second cutting body 16 is useful for cutting food items into uniform wedges. Thus, the second cutting body 16 is useful for cutting and slicing smaller items, including tomatoes, oranges, peaches, and onions, just to name a few.

Referring to FIG. 4, the second cutting body 16 is adapted for engagement with the platform 19, so that the cutting

body remains stable during use. For example, the platform **19** may include a channel **19e** on the third or top level surface **19c** of the platform. The channel **19e** has a width complimentary to the width of the outer rim **16d** of the cutting body **16**. The outer rim **16d** may be snap fit into the channel **19e** of the platform, securing the cutting body into place over the food item to be cut.

Referring to FIG. 6, a cover **20** is adapted for placement over the first cutting body **12**. As shown, the cover **20** has a semispherical or bowl shape, which complements the cutting bodies previously described. Additionally, the cover **20** includes a flattened section **21**, so that if the cover is turned over onto the flattened section, the cover is stable and will be prevented from rolling. The cover **20** may be inverted, with the opening on the top thereof, and used as a bowl. In addition, the first cutting body **12** may be placed with its opening at the top thereof in face-to-face relation to the cover **20** to form a spherical body (not shown) that may contain cut food items therein for shaking and blending of the food items, such as to make a chopped salad, or other like food blend.

Referring to FIGS. 7 and 8, there is shown the cover **20** engaged in a closed position with the base **18** and platform **19**. Specifically, as shown in detail in FIG. 8, the cover **20** includes a lip **20a** around the outer circumference of the rim **20b** of the cover. The lip **20a** engages in a snap-fit configuration with a ledge **19f** on the first level **19a** of the platform. In this manner, the cover **20** can be secured to the base **18** and its platform **19**, thereby enclosing all of the components of the apparatus **10** for transportation and storage.

Referring now to FIGS. 9-11, there is shown the present apparatus **10** in use with a cutting implement, and specifically a multi-bladed knife **40**. It should be understood that the present apparatus **10** is suitable for receiving a standard, single bladed knife, as the slots provided in both the first cutting body **12** and second cutting body **16** are capable of receiving a standard knife blade. However, the present multi-bladed knife **40**, when used with the embodiment of the present cutting apparatus **10**, provides a system that saves considerable time in the food preparation process. Cutting and slicing food items, such as vegetables, for use in a salad or other dishes can require a certain amount of knife skills, and often be the most tedious chore in food preparation. Using the multi-bladed **40** knife with the present cutting apparatus makes this step in the preparation much quicker and easier as the system simultaneously creates multiple cuts with a single swipe of the blades through the slots of the apparatus.

Although the multi-bladed knife **40** is illustrated with five blades, it should be understood that the multi-bladed knife **40** may have any number of blades for aiding a user in easily and quickly cutting a food item therein, and should not be limited as described herein. The blades of the multi-bladed knife **40** are generally spaced apart in parallel relation from each other to align with a plurality of the parallel slots **14** within the first cutting body **12**. The blades may be aligned with adjacent slots **14** of the first cutting body **12**, or non-adjacent slots. For example, adjacent blades of the multi-bladed knife **40** may align with non-adjacent slots, such as skipping one or more slots. Thus, the multi-bladed knife **40** may be used to provide relatively thick slices of food products, although thinner food slices may also be accomplished by moving the multi-bladed knife **40** into different non-adjacent slots within the first cutting body **12**.

FIG. 12 represents yet another embodiment of the present cutting apparatus **100**. In this embodiment, the platform **50** includes a wave pattern **50a** having a shorter wave length

than that of the previous embodiment. Although not shown, it is understood that this wave pattern **50a** would engage with and first cutting body having a complementary wave pattern, as previously described.

Using the present cutting apparatus **10** in a method for cutting and processing food items begins with placing the food items to be processed on the platform **19**, specifically the third or top level **19c** of the platform. If the first cutting body **12** is being used, the outer wave pattern rim **30** of the body is aligned with the corresponding wave pattern **19d** on the second level **19b** of the platform **19**. Once the first cutting body **12** is engaged with the platform **19**, the multi-bladed knife **40** is passed through the slots **14** in a first direction, to initially cut the food items (FIGS. 7 and 8). Taking the handle **22** of the base **18**, and while lifting the first cutting body **12** slightly away from the platform to disengage the rim **30** from the platform **19b** the base **18** and platform **19** are rotated by grasping the handle **22**. The wave pattern on the rim **30** of the body **12** is then aligned again with the next wave pattern **19d** on the platform. The multi-bladed knife **40** (or single blade knife, if being used), is again passed through the slots **14** and into the food item for further cutting or slicing. These steps, rotation of the platform **19** and alignment with the cutting body **12**, are repeated until the food item is sliced or cut to the desired consistency.

A similar approach is used when the second cutting body **16** is used. The food item is placed on the platform **19** and the second cutting body is snap-fit into the channel **19e** on the top level **19c** of the platform, to cover the food item. However, rather than the multi-bladed knife, a standard single blade knife (not shown) is passed repeatedly through the slots **16b** of the second cutting body **16**, until the item is cut into uniform wedges. The cut food item could then be removed, along with the second cutting body **16** prior attaching the first cutting body **12**, or the food items may remain on the platform **19** for additional processing when the first cutting body is secured to the base **18**.

Certainly, the present cutting apparatus **10** provides several options with regard to processing, cutting and slicing food items. Additionally, the modular fit of the components of the apparatus **10** gives the users various cutting options, as well as, the option to mix the final cut or sliced food products together within the apparatus. The plurality of slots within the first and second cutting bodies provide the advantage of simultaneously cutting food items into multiple pieces, saving time in the overall process. Furthermore, use of the cutting bodies act as a shield between the food items being cut, the cutting implements and the fingers and hands of the user. The cutting bodies, platform, base and cover can be constructed from any material that is easily cleaned and suitable for use with food, including silicone and plastic.

It should be noted that various changes and modifications to the presently preferred embodiments described herein will be apparent to those skilled in the art. Such changes and modifications may be made without departing from the spirit and scope of the present invention and without diminishing its attendant advantages. Further, references throughout the specification to "the invention" are nonlimiting, and it should be noted that claim limitations presented herein are not meant to describe the invention as a whole. Moreover, the invention illustratively disclosed herein suitably may be practiced in the absence of any element which is not specifically disclosed herein.

We claim:

1. A cutting apparatus comprising:
 - a first cutting body having a surface forming a dome shape and an outer rim, wherein a circumference of the outer rim forms a first sinusoidal wave pattern, wherein the first wave pattern is configured to have an amplitude running vertically within the outer rim when the outer rim is placed on a horizontal surface;
 - a plurality of parallel slots passing through the surface of the dome of the first cutting body; and,
 - a base having a first surface forming a second sinusoidal wave pattern, wherein the second wave pattern is configured to have an amplitude running vertically within the base when the base is disposed on a horizontal surface and configured to contact and fit within the first wave pattern of the circumference of the outer rim of the first cutting body when the first cutting body is disposed on the base in a dome configuration, wherein the base further comprises a second surface configured to be a horizontal cutting surface for a food item placed thereon and under the first cutting body when the base is placed on a horizontal surface, wherein each of the plurality of slots adapted to receive and guide a cutting device therethrough to cut the food item placed on the second surface.
2. The cutting apparatus of claim 1, wherein the first cutting body comprises a plurality of ribs, each rib disposed between two of the plurality of slots, wherein each rib comprises a peak and angled sides and are adapted to receive and guide the cutting device within one of the plurality of slots.
3. The cutting apparatus of claim 1, wherein the base further includes a handle extending from an outer edge of the base.

4. The cutting apparatus of claim 1, wherein the base further includes a platform.
5. The cutting apparatus of claim 4, wherein the platform includes a first level and a second level, wherein an outer circumference of the first level is greater than an outer circumference of the second level.
6. The cutting apparatus of claim 5, wherein the outer circumference of the second level of the platform includes a wave pattern.
7. The cutting apparatus of claim 6, wherein the wave pattern on the outer circumference of the second level of the platform engages with the wave pattern on the circumference of the rim of the first cutting body for releasably securing the first cutting body to the base.
8. The cutting apparatus of claim 1, wherein the apparatus further includes a second cutting body having a semispherical inner space for receiving an item to be cut, the second cutting body disposed within the inner space of the first cutting body.
9. The cutting apparatus of claim 8, wherein the second cutting body is releaseably engaged to the base.
10. The cutting apparatus of claim 8, wherein the second cutting body includes a plurality of radially arranged slots intersecting at a top surface of the second cutting body.
11. The cutting apparatus of claim 1, wherein the apparatus further includes an outer body having a semispherical shape forming an inner space for receiving the first cutting body.
12. The cutting apparatus of claim 11, wherein the outer body releaseably engages with the base.
13. The cutting apparatus of claim 1 wherein the first surface of the base is further configured to provide at least two discrete positions for the outer rim of the first cutting body when the first cutting body is disposed thereon.

* * * * *