

(12) **United States Patent**
Hammond et al.

(10) **Patent No.:** **US 10,119,738 B2**
(45) **Date of Patent:** **Nov. 6, 2018**

(54) **AIR CONDITIONING SYSTEM WITH VAPOR INJECTION COMPRESSOR**

(71) Applicant: **WaterFurnace International, Inc.**,
Fort Wayne, IN (US)

(72) Inventors: **Timothy A. Hammond**, Harlan, IN
(US); **Robert R. Brown**, Markle, IN
(US)

(73) Assignee: **WaterFurnace International Inc.**, Fort
Wayne, IN (US)

(*) Notice: Subject to any disclaimer, the term of this
patent is extended or adjusted under 35
U.S.C. 154(b) by 302 days.

(21) Appl. No.: **14/862,762**

(22) Filed: **Sep. 23, 2015**

(65) **Prior Publication Data**

US 2016/0091236 A1 Mar. 31, 2016

Related U.S. Application Data

(60) Provisional application No. 62/056,082, filed on Sep.
26, 2014.

(51) **Int. Cl.**
F25B 41/00 (2006.01)
F25B 49/02 (2006.01)
F25B 13/00 (2006.01)

(52) **U.S. Cl.**
CPC **F25B 49/02** (2013.01); **F25B 13/00**
(2013.01); **F25B 2313/003** (2013.01);
(Continued)

(58) **Field of Classification Search**
CPC **F25B 49/02**; **F25B 13/00**
(Continued)

(56) **References Cited**

U.S. PATENT DOCUMENTS

4,835,976 A * 6/1989 Torrence F25B 41/062
62/115

5,136,855 A 8/1992 Lenarduzzi et al.
(Continued)

FOREIGN PATENT DOCUMENTS

CN 1987397 A 6/2007
CN 201944952 U 8/2011

(Continued)

OTHER PUBLICATIONS

Ekaterina Vinogradova, Economizers in Chiller Systems, Mikkelin
Ammattikorkeakoulu, Nov. 2012 (50 pages).

(Continued)

Primary Examiner — Henry Crenshaw

(74) *Attorney, Agent, or Firm* — Neal, Gerber &
Eisenberg LLP; Thomas E. Williams

(57) **ABSTRACT**

An air conditioning system can be toggled between a heating mode, in which heat is withdrawn from a source (e.g., a geothermal source) and deposited into a conditioned space (e.g., a building), and a cooling mode, in which heat is withdrawn from the conditioned space and deposited into the source. The air conditioning system uses a combination of efficiency-enhancing technologies, including injection of superheated vapor into the system's compressor from an economizer circuit, adjustable compressor speed, the use of one or coaxial heat exchangers and the use of electronic expansion valves that are continuously adjustable from a fully closed to various open positions. A controller may be used to control the system for optimal performance in both the heating and cooling modes, such as by disabling the economizer circuit and vapor injection when the system is in the cooling mode.

19 Claims, 6 Drawing Sheets

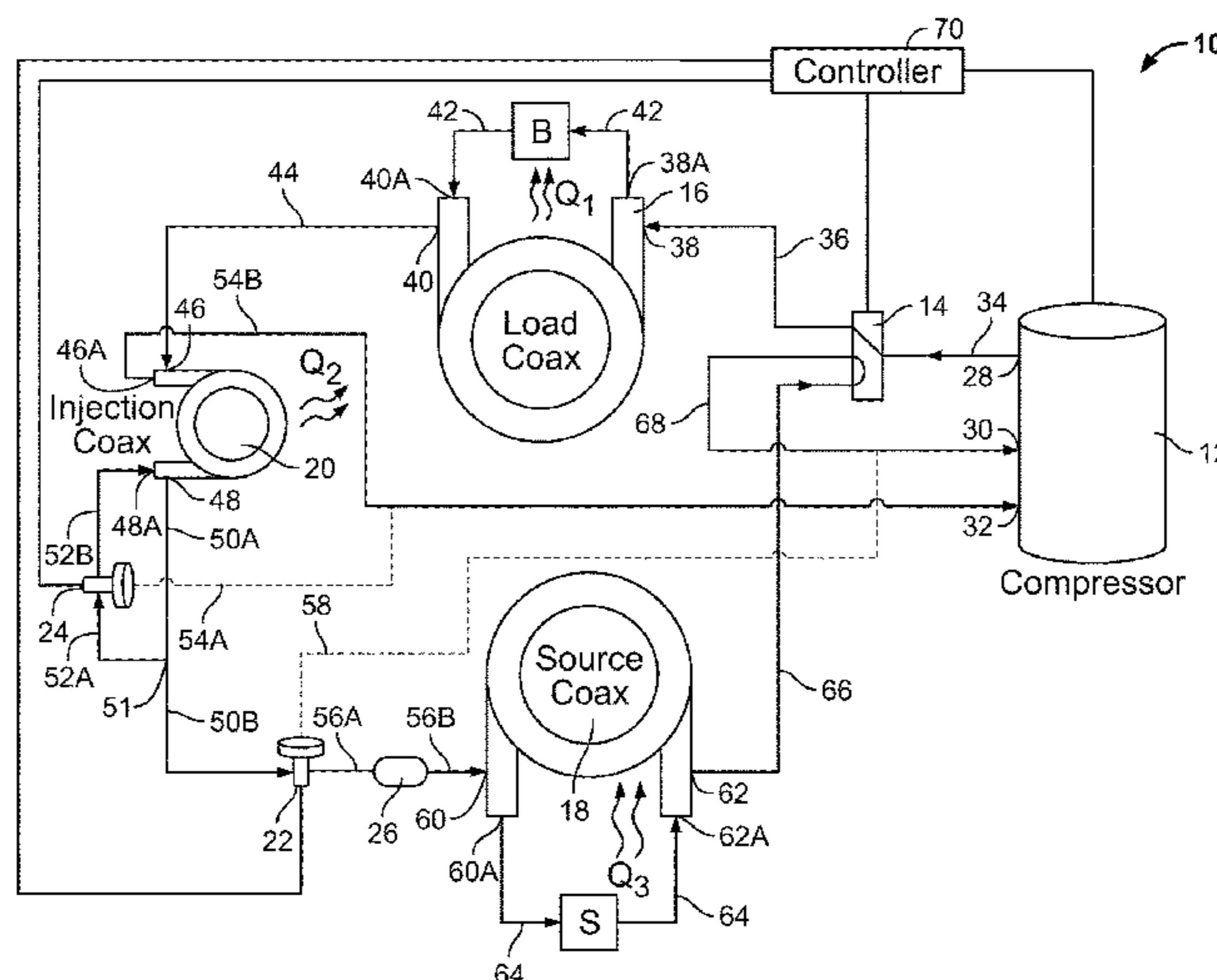

(52) **U.S. Cl.**
 CPC . *F25B 2313/004* (2013.01); *F25B 2313/0292* (2013.01); *F25B 2313/0311* (2013.01); *F25B 2341/065* (2013.01); *F25B 2600/0253* (2013.01); *F25B 2600/2509* (2013.01); *F25B 2600/2513* (2013.01); *Y02B 30/72* (2013.01); *Y02B 30/741* (2013.01)

(58) **Field of Classification Search**
 USPC 62/207
 See application file for complete search history.

(56) **References Cited**

U.S. PATENT DOCUMENTS

5,224,357 A	7/1993	Galiyano et al.	2008/0196418 A1	8/2008	Lifson et al.	
5,461,876 A	10/1995	Dressler et al.	2008/0209930 A1*	9/2008	Taras	F25B 13/00 62/228.1
5,651,265 A	7/1997	Grenier	2008/0256975 A1	10/2008	Lifson et al.	
5,758,514 A	6/1998	Genung et al.	2008/0282718 A1	11/2008	Beagle	
5,927,088 A *	7/1999	Shaw	2008/0302129 A1	12/2008	Mosemann et al.	
			2008/0307813 A1	12/2008	Lifson et al.	
			2009/0208331 A1	8/2009	Haley et al.	
6,032,472 A	3/2000	Heinrichs et al.	2010/0005831 A1	1/2010	Vaisman et al.	
6,070,423 A	6/2000	Hebert	2010/0024470 A1	2/2010	Lifson et al.	
6,167,715 B1	1/2001	Hebert	2010/0058781 A1	3/2010	Lifson et al.	
6,434,960 B1	8/2002	Rousseau	2010/0114384 A1	5/2010	Maxwell	
6,474,087 B1	11/2002	Lifson	2010/0132399 A1	6/2010	Mitra et al.	
6,694,750 B1	2/2004	Lifson et al.	2010/0199715 A1	8/2010	Lifson et al.	
6,817,205 B1	11/2004	Lifson et al.	2010/0251750 A1	10/2010	Lifson et al.	
6,857,285 B2	2/2005	Hebert	2010/0281894 A1	11/2010	Huff	
6,892,553 B1	5/2005	Lifson et al.	2010/0287969 A1	11/2010	Ueda et al.	
6,931,879 B1	8/2005	Wiggs	2010/0326100 A1	12/2010	Taras et al.	
6,938,438 B2	9/2005	Lifson et al.	2011/0023515 A1	2/2011	Kopko et al.	
6,941,770 B1	9/2005	Taras et al.	2011/0036119 A1*	2/2011	Fujimoto	F25B 1/10 62/510
7,000,423 B2	2/2006	Lifson et al.	2011/0041523 A1	2/2011	Taras et al.	
7,059,151 B2	6/2006	Taras et al.	2011/0094248 A1	4/2011	Taras et al.	
7,114,349 B2	10/2006	Lifson et al.	2011/0094259 A1	4/2011	Lifson et al.	
7,150,160 B2	12/2006	Herbert	2011/0132007 A1	6/2011	Weyna et al.	
RE39,597 E	5/2007	Rousseau	2011/0174014 A1	7/2011	Scarcella et al.	
7,228,707 B2	6/2007	Lifson et al.	2011/0203299 A1	8/2011	Jing et al.	
7,272,948 B2	9/2007	Taras et al.	2011/0209490 A1	9/2011	Mijanovic et al.	
7,275,385 B2	10/2007	Abel et al.	2011/0289950 A1	12/2011	Kim et al.	
7,325,414 B2	2/2008	Taras et al.	2012/0011866 A1	1/2012	Scarcella et al.	
7,484,374 B2	2/2009	Pham et al.	2012/0067965 A1*	3/2012	Rajasekaran	B64F 1/362 236/44 C
7,617,697 B2	11/2009	McCaughan	2012/0103005 A1	5/2012	Kopko et al.	
7,654,104 B2	2/2010	Groll et al.	2012/0198867 A1	8/2012	Ng et al.	
7,845,190 B2	12/2010	Pearson	2012/0247134 A1	10/2012	Gurin	
7,854,137 B2	12/2010	Lifson et al.	2013/0031934 A1	2/2013	Huff et al.	
7,856,834 B2	12/2010	Haley	2013/0098085 A1	4/2013	Judge et al.	
7,958,737 B2	6/2011	Lifson et al.	2013/0180266 A1	7/2013	Bois	
7,975,506 B2	7/2011	James et al.	2013/0269378 A1*	10/2013	Wong	F25B 13/00 62/160
7,997,092 B2	8/2011	Lifson et al.	2013/0305756 A1	11/2013	Gomes et al.	
8,037,713 B2	10/2011	Haley et al.	2014/0013782 A1*	1/2014	Kopko	A63B 57/00 62/115
8,074,459 B2	12/2011	Murakami et al.	2014/0013788 A1	1/2014	Kopko et al.	
8,079,228 B2	12/2011	Lifson et al.	2014/0033753 A1	2/2014	Lu et al.	
8,079,229 B2	12/2011	Lifson et al.	2014/0033755 A1	2/2014	Wong	
8,082,751 B2	12/2011	Wiggs	2014/0053585 A1	2/2014	Huff	
8,136,364 B2	3/2012	Lifson et al.	2014/0060101 A1	3/2014	Styles et al.	
8,191,376 B2	6/2012	Fox et al.	2015/0059373 A1*	3/2015	Maiello	F25B 49/022 62/115
8,220,531 B2	7/2012	Murakami et al.	2017/0227250 A1*	8/2017	Karamanos	F24F 13/0272
8,418,482 B2	4/2013	Bush et al.				
8,418,486 B2	4/2013	Taras et al.				
8,424,326 B2	4/2013	Mitra et al.				
8,459,052 B2	6/2013	Bush et al.				
8,528,359 B2	9/2013	Lifson et al.				
8,561,425 B2	10/2013	Mitra et al.				
8,733,429 B2*	5/2014	Harrison				F24D 11/0221 165/240
8,769,982 B2	7/2014	Ignatiev et al.				
2006/0010908 A1*	1/2006	Taras				F24F 3/153 62/513
2006/0225445 A1	10/2006	Lifson et al.				
2007/0074536 A1	4/2007	Bai				
2007/0289319 A1	12/2007	Kim et al.				
2007/0295477 A1	12/2007	Mueller et al.				
2008/0016895 A1	1/2008	Kim et al.				
2008/0173034 A1*	7/2008	Shaw				F25B 13/00 62/160

FOREIGN PATENT DOCUMENTS

CN	102353126 A	2/2012
CN	203231582 U	10/2013
CN	103471275 A	12/2013
CN	203396155 U	1/2014
CN	203432025 U	2/2014
EP	1983275 A1	10/2008
KR	100963221 B1	6/2010
WO	2014031559 A1	2/2014
WO	2014031708 A1	2/2014

OTHER PUBLICATIONS

Enhanced Vapour Injection (EVI) for ZH*KVE Scroll Compressors, Emerson Climate Technologies—Technical Information C7.4. 3/1107-0512/E, May 2012 (10 pages).

Wei Yang et al., The Design Method of U-Bend Geothermal Heat Exchanger of DX-GCHP in Cooling Model, IEEE, 2011, pp. 3635-3637 (English Abstract) (3 pages).

Tolga N. Aynur, Variable Refrigerant Flow Systems: A Review, Energy and Buildings, Jan. 2010, pp. 1106-1112, vol. 42 (7 pages).

John P. Elson et al., Scroll Technology: An Overview of Past, Present and Future Developments, International Compressor Engineering Conference, 2008, Paper 1871 (9 pages).

(56)

References Cited

OTHER PUBLICATIONS

B.P. Rasmussen et al., Model-Driven System Identification of Transcritical Vapor Compression Systems, IEEE Transactions on Control Systems Technology, May 2005, pp. 444-451, vol. 13 (8 pages).

134-XS and 134-S Series Compressors ECONomizer (EA-12-03-E), 134-XS and 134-S series—Application and Maintenance Manual, Technical report EA1203E, RefComp Refrigerant Compressors, undated but believed to be publicly available at least as early as Mar. 2014 (4 pages).

Economized Vapor Injection (EVI) Compressors, Emerson Climate Technologies Application Engineering Bulletin AE4-1327 R2, Revised Sep. 2006 (9 pages).

Henrik Haraldsson et al., Measurement of Performance and Evaluation of a Heat Pump—With Scroll Compressor EVI and Economizer, 2006 (4 pages).

J. Lund et al., Geothermal (Ground-Source) Heat Pumps a World Overview, GHC Bulletin, Sep. 2004, (10 pages).

* cited by examiner

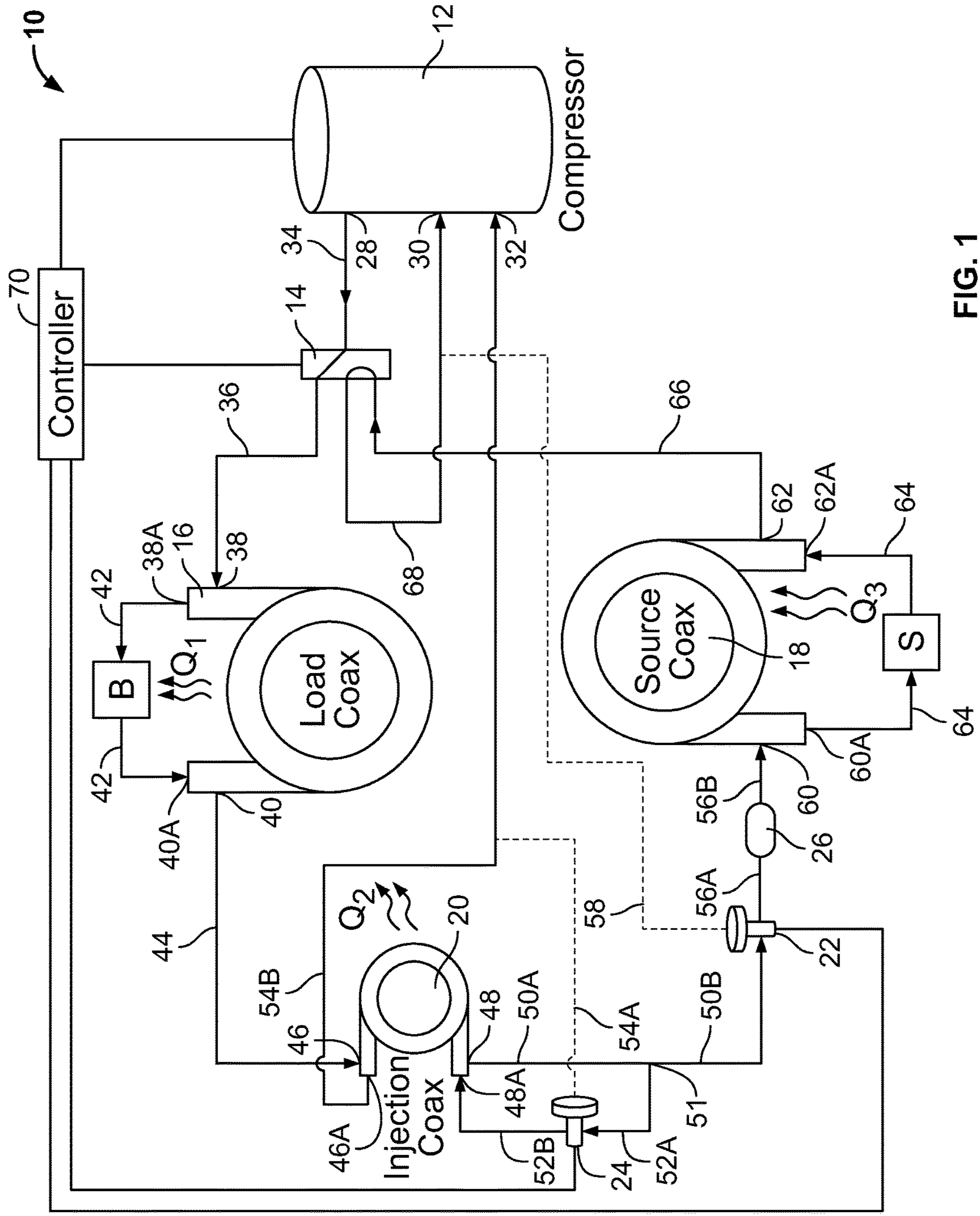

FIG. 1

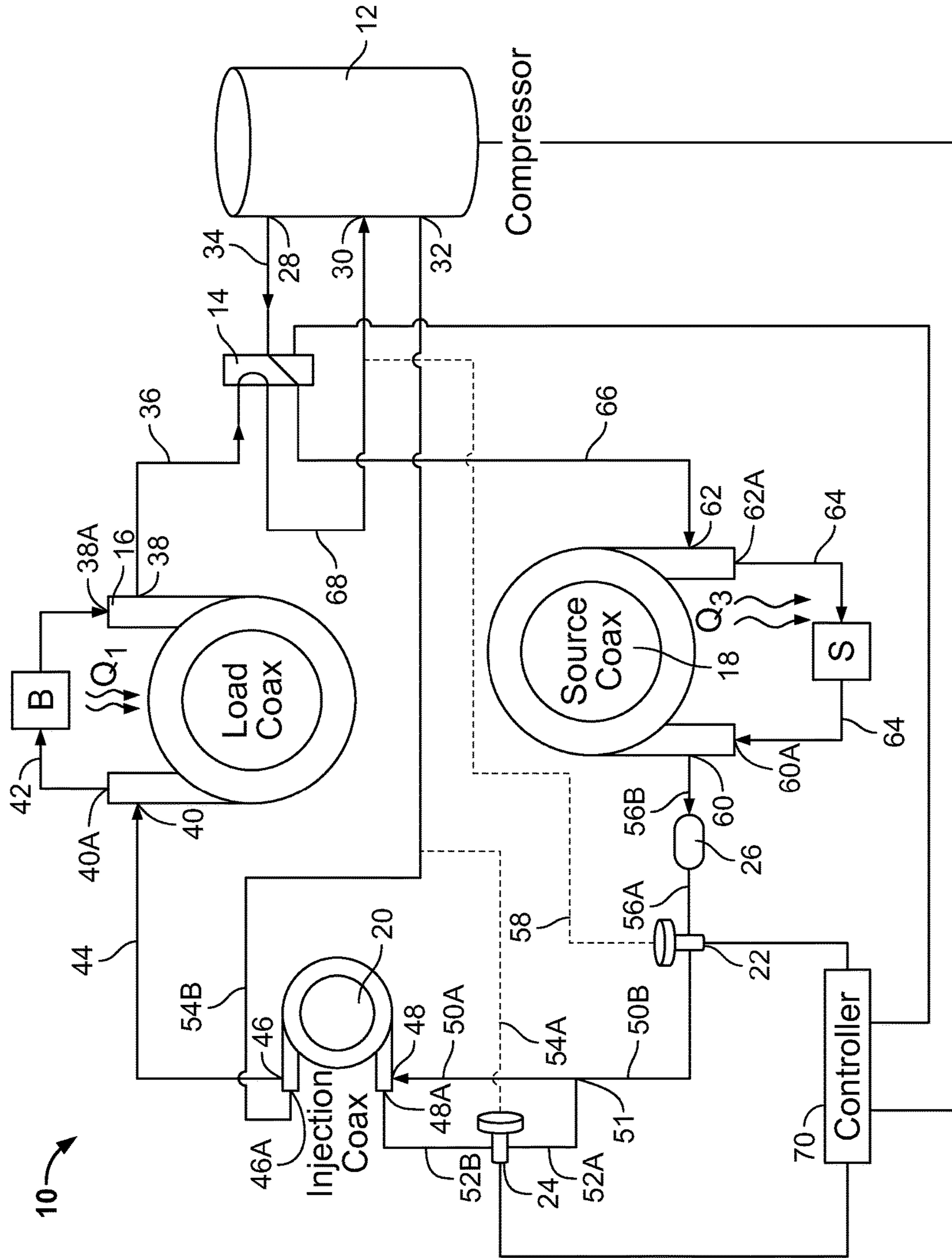

FIG. 2

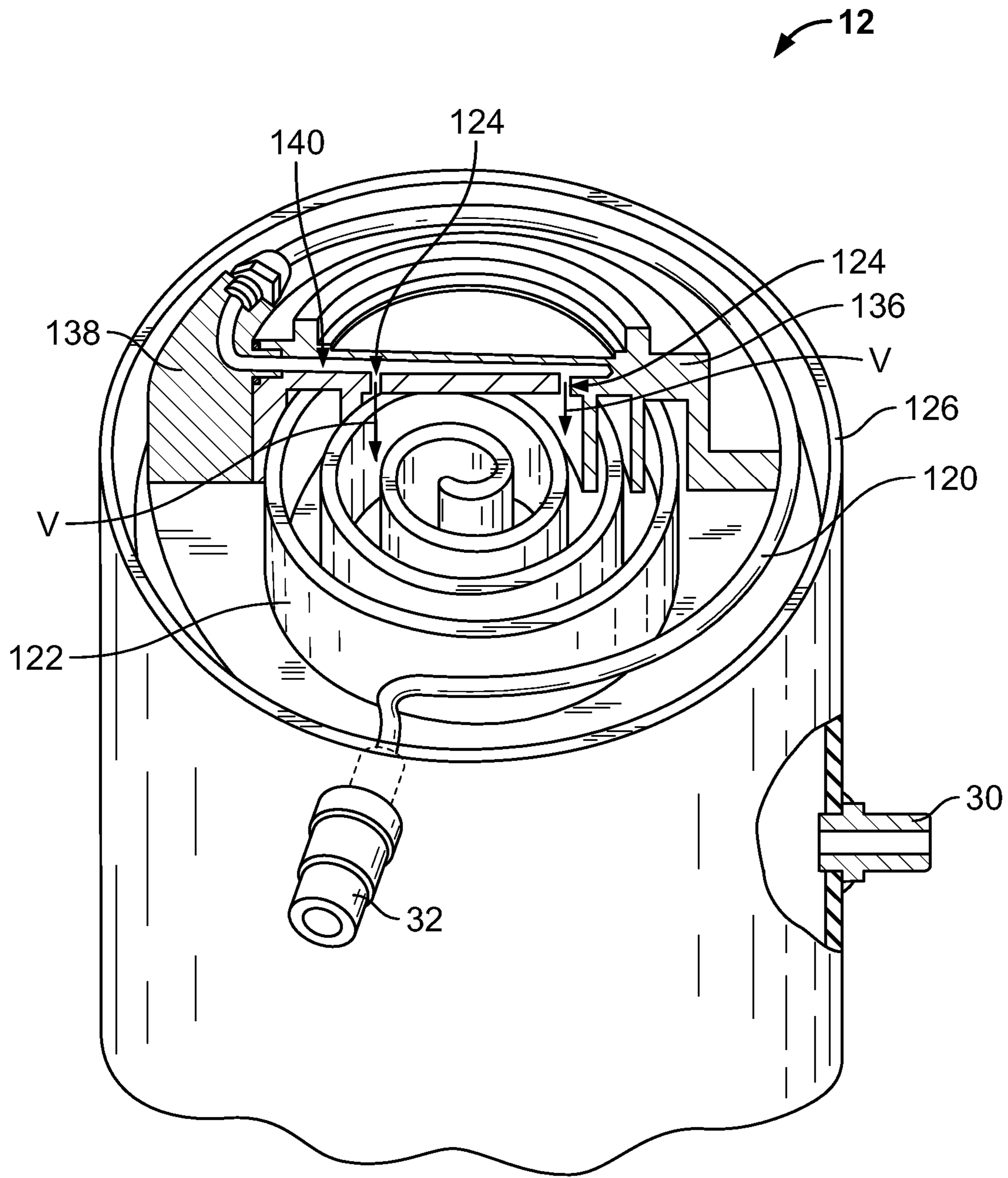

FIG. 3

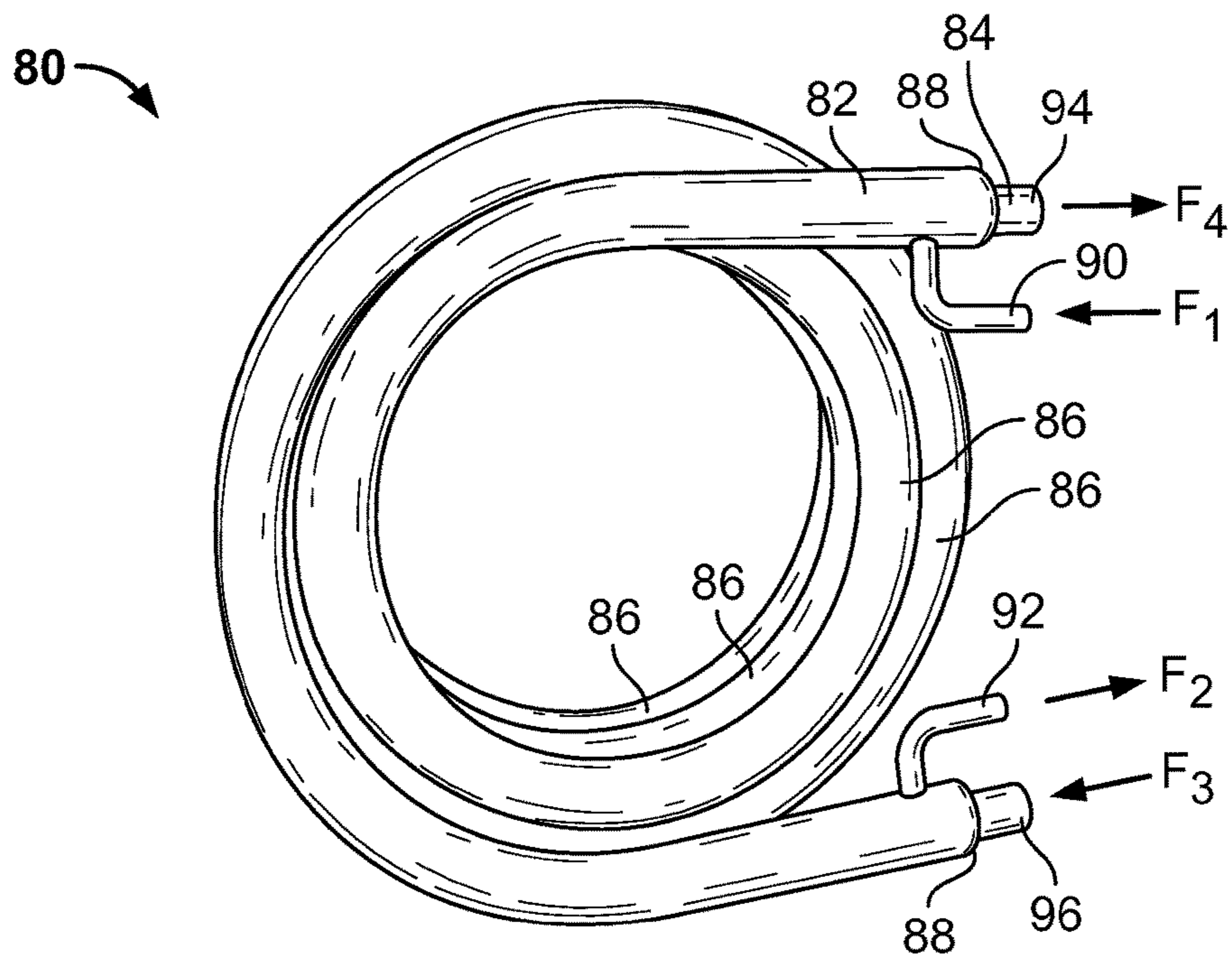

FIG. 4

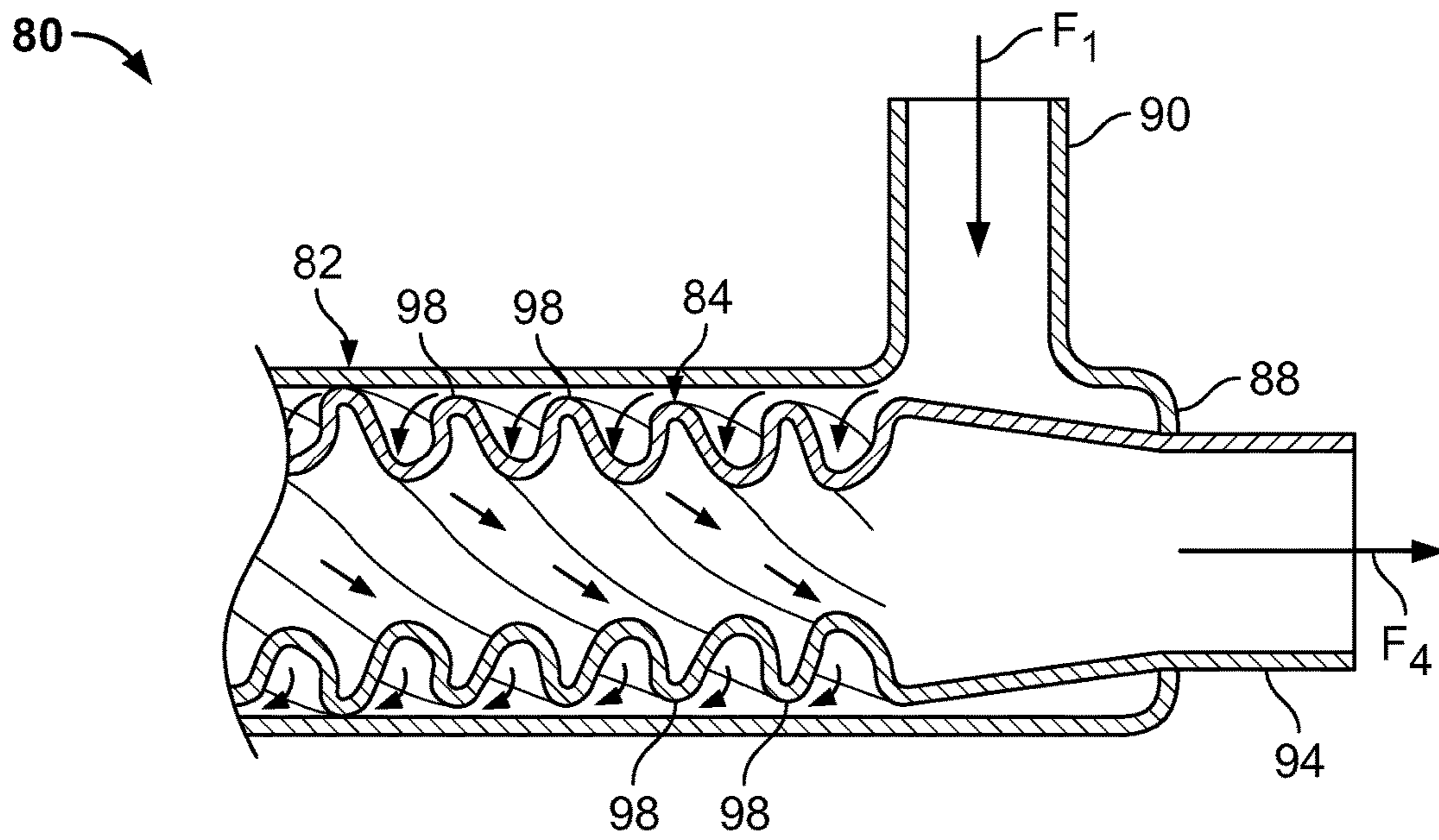

FIG. 5

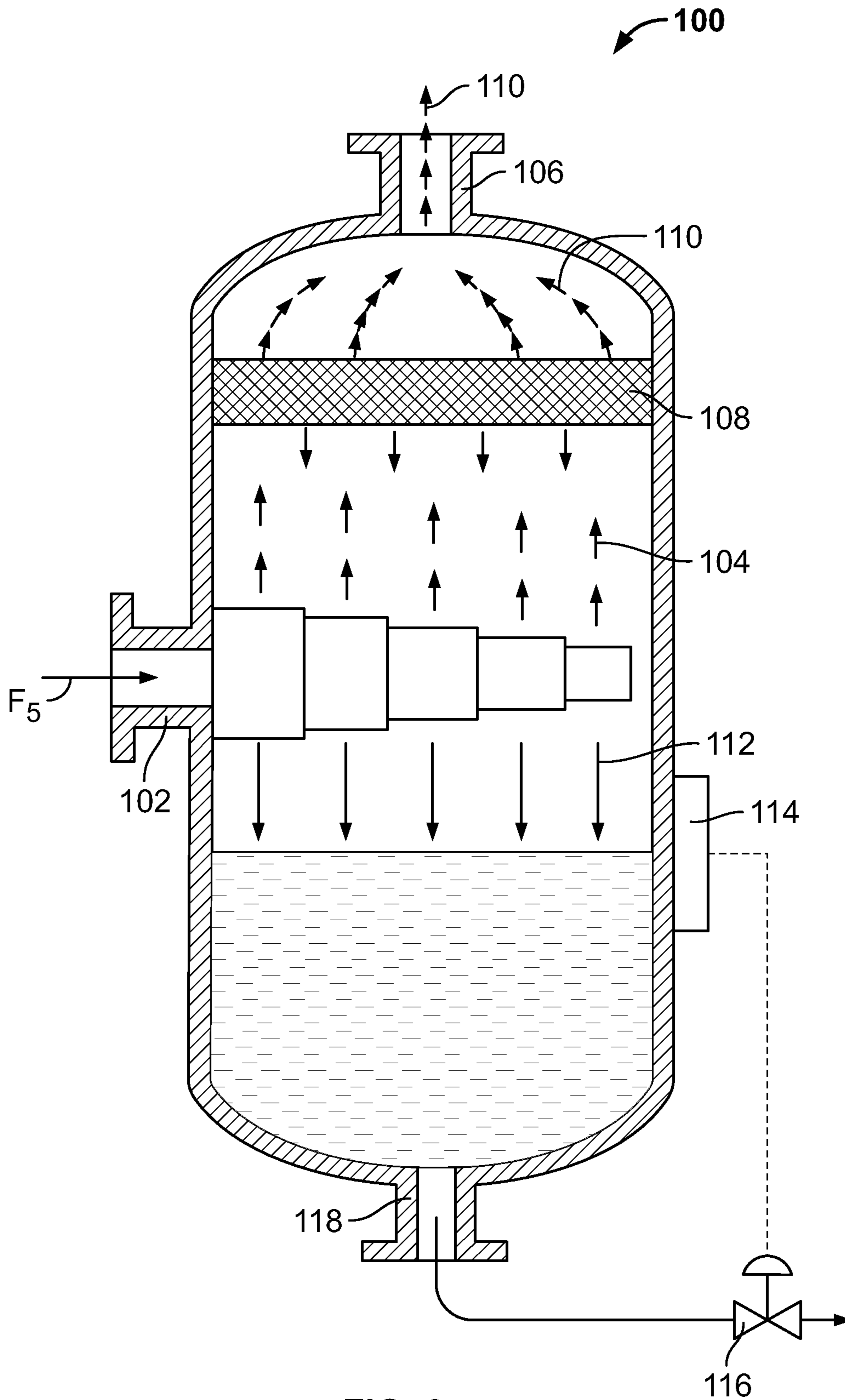

FIG. 6

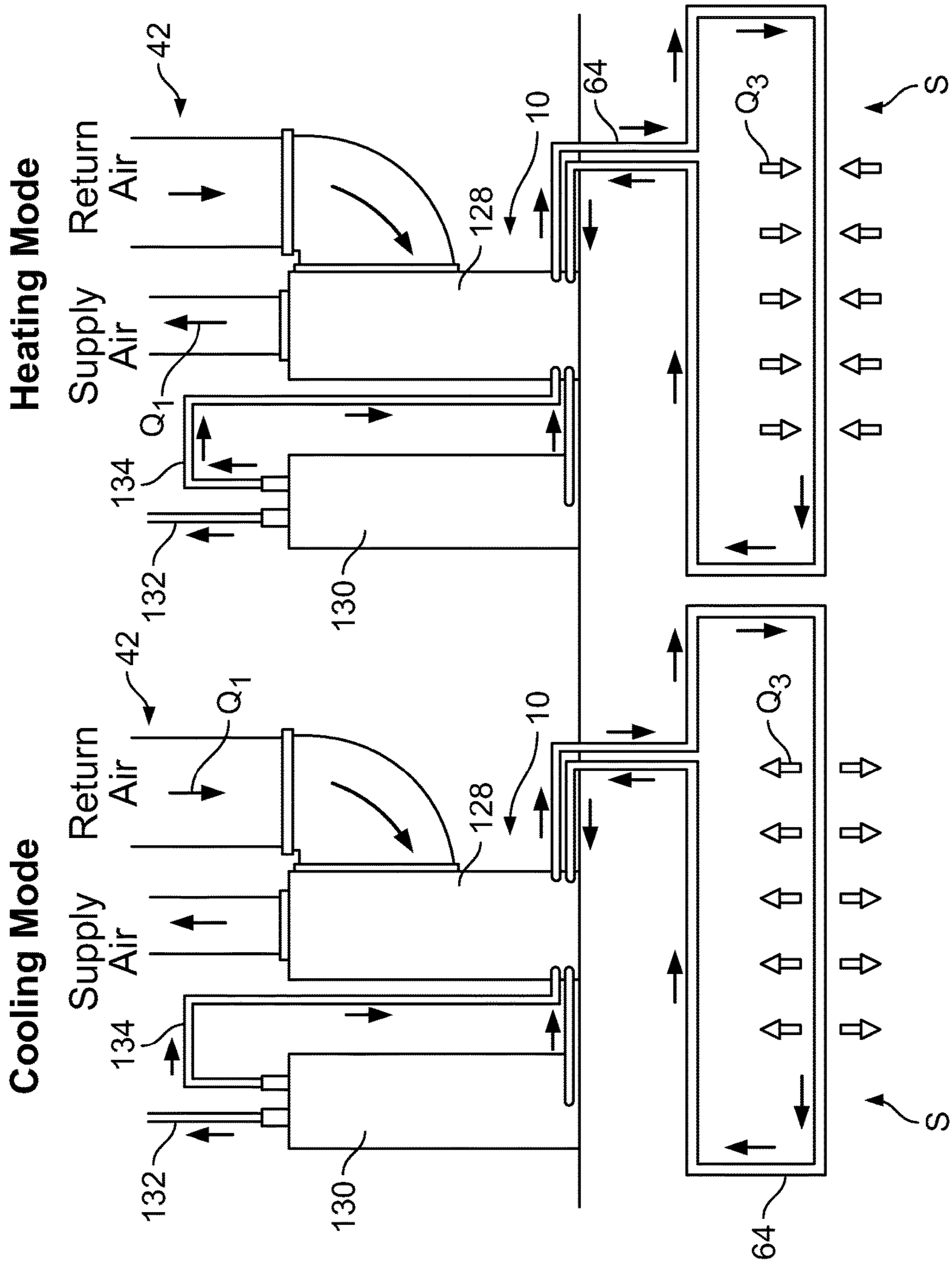

FIG. 7

AIR CONDITIONING SYSTEM WITH VAPOR INJECTION COMPRESSOR

CROSS REFERENCE TO RELATED APPLICATIONS

This application claims the benefit of and priority to U.S. Provisional Patent Application No. 62/056,082 filed on Sep. 26, 2014 entitled AIR CONDITIONING SYSTEM WITH VAPOR INJECTION COMPRESSOR, which is incorporated by reference herein in its entirety.

BACKGROUND

1. Technical Field

The present disclosure relates to air conditioning systems and, in particular, to efficient-enhanced reversible air conditioning systems capable of both heating and refrigeration.

2. Description of the Related Art

Heating and cooling systems may include a compressor for compressing a working refrigerant fluid, a condenser heat exchanger for extracting heat from the refrigerant fluid, an expansion valve, and an evaporator heat exchanger for extracting heat from an external source. In some instances, such refrigeration systems may further include an economizer heat exchanger and/or a vapor injection feature associated with the compressor for increasing both the capacity and the efficiency of the compressor.

In typical refrigeration systems, the refrigerant is a high pressure hot liquid upon leaving the compressor, is a high pressure warm liquid downstream of the condenser, is a low pressure warm gas downstream of the expansion valve, and is a low pressure cool gas downstream of the evaporator.

An economizer may be used to further influence the thermal state of the refrigerant between the condenser and evaporator. An auxiliary refrigerant flow is tapped from the main refrigerant flow downstream of the economizer heat exchanger and passed through an expansion valve to expand the auxiliary refrigerant flow before same is passed back through the economizer heat exchanger in heat exchange relation with the main refrigerant flow. This serves to further subcool the main refrigerant flow upstream of the evaporator.

The economizer heat exchanger also discharges an auxiliary refrigerant flow in the form of an intermediate pressure vapor, which is then injected into the compressor. Typically a scroll compressor is used in connection with such a system, and the vapor is injected at an intermediate pressure location within the wraps of the scroll compressor.

Further increases in efficiency and capacity are desirable in air conditioning systems, in order to increase system efficacy and/or decrease the cost of operating the system.

SUMMARY

The present disclosure provides an air conditioning system which can be toggled between a heating mode, in which heat is withdrawn from a source (e.g., a geothermal source) and deposited into a conditioned space (e.g., a building), and a cooling mode, in which heat is withdrawn from the conditioned space and deposited into the source. The air conditioning system uses a combination of efficiency-enhancing technologies, including injection of superheated vapor into the system's compressor from an economizer circuit, adjustable compressor speed, the use of one or more coaxial heat exchangers and the use of electronic expansion valves that are continuously adjustable from a fully closed to

various open positions. A controller may be used to control the system for optimal performance in both the heating and cooling modes, such as by disabling the economizer circuit and vapor injection when the system is in the cooling mode.

BRIEF DESCRIPTION OF THE DRAWINGS

The above mentioned and other features and objects of this invention, and the manner of attaining them, will become more apparent and the invention itself will be better understood by reference to the following description of embodiments of the invention taken in conjunction with the accompanying drawings, wherein:

FIG. 1 is a schematic illustration of an air conditioning system in accordance with the present disclosure, illustrating refrigerant flow in a heating mode;

FIG. 2 is another schematic illustration of the air conditioning system shown in FIG. 1, with refrigerant flow reversed for a cooling mode;

FIG. 3 is an elevation view of a scroll compressor including vapor injection in accordance with the present disclosure;

FIG. 4 is a perspective view of a coaxial heat exchanger used in the air conditioning system shown in FIG. 1;

FIG. 5 is an elevation, cross-sectional view of a portion of the coaxial heat exchanger shown in FIG. 4, illustrating fluid flow therethrough;

FIG. 6 is an elevation, cross-section view of a flash tank used in some air conditioning systems for separating entrained liquid from vapor; and

FIG. 7 is a schematic view of a geothermal air conditioning system in accordance with the present disclosure.

Corresponding reference characters indicate corresponding parts throughout the several views. Although the exemplifications set out herein illustrate embodiments of the invention, the embodiments disclosed below are not intended to be exhaustive or to be construed as limiting the scope of the invention to the precise form disclosed.

DETAILED DESCRIPTION

For purposes of the present disclosure, "air conditioning" refers to both heating and cooling a conditioned space (e.g., the inside of a building). In particular and as described in detail below, an air conditioning system may be reversible to cool a conditioned space while exhausting heat to a source (e.g., a geothermal source), or to heat a conditioned space by extracting heat from the source.

For purposes of the present disclosure, "superheated vapor" refers to a vapor whose temperature is measurably above its liquid/vapor phase change temperature for a given vapor pressure.

For purposes of the present disclosure, "subcooled liquid" refers to a liquid whose temperature is measurably below its liquid/vapor phase change temperature for a given ambient vapor pressure.

For purposes of the present disclosure, "vapor mixture" refers to mixed liquid-and-vapor phase fluid in which the fluid can undergo phase changes (i.e., from liquid to saturated vapor or from saturated vapor to liquid) at constant pressure and temperature.

Referring generally to FIGS. 1 and 2, the present disclosure provides air conditioning system 10 which is reconfigurable between a heating mode (FIG. 1) and a cooling mode (FIG. 2). Such reconfiguration may be accomplished by actuation of a four way reversing valve 14, which reverses the direction of refrigerant flow among the various

components of system **10**, thereby reversing the flow of heat to and from a source **S** (e.g., a geothermal source) and a load **B** (e.g., the interior of a building or other thermally conditioned space). System **10** may further include an economizer heat exchanger **20** which enables a vapor injection feature to enhance the efficiency and function of the compressor **12** in the heating mode, but may not be needed in the cooling mode. As described in detail below, the toggling of reversing valve **14** from the heating mode to the cooling mode may be accompanied by adjusting an economizer expansion valve **24** to cease refrigerant flow therethrough, effectively disabling the vapor injection in the cooling mode.

Regardless of whether air conditioning system **10** is utilized for heating or cooling a conditioned space, the same set of components all remain disposed in the system flow path, the specific functions of which are discussed in detail below. System **10** includes compressor **12** fluidly connected to load heat exchanger **16** and source heat exchanger **18** via reversing valve **14**. Operably interposed between load heat exchanger **16** and source heat exchanger **18** is economizer heat exchanger **20**. Primary expansion valve **22** is operably interposed between economizer **20** and source heat exchanger **18**, while economizer expansion valve **24** selectively receives a portion of the refrigerant flow and discharges to economizer **20** in the heating mode. In the cooling mode of FIG. 2, economizer expansion valve **24** prevents one of the two flows of refrigerant through economizer heat exchanger **20**, effectively nullifying the effect of economizer **20** on the thermal characteristics of air conditioning system **10**, as also described in detail below.

1. Reversible Heating and Cooling

Air conditioning system **10** is configured as a reversible heat pump. In a heating mode, refrigerant flow through system **10** sends hot refrigerant through load heat exchanger **16**, which operates as a condenser depositing heat Q_1 into a conditioned space **B**, while cold refrigerant is sent through a source heat exchanger **18** which operates as an evaporator to withdraws heat Q_3 from a source **S**, e.g., a geothermal source. In a cooling mode, the roles of load and source heat exchangers **16**, **18** are reversed, as described further below such that load heat exchanger **16** operates as an evaporator and source heat exchanger **18** operates as a condenser.

FIG. 1 illustrates air conditioning system **10** in the heating mode. Compressor **12** receives refrigerant in a low-pressure superheated vapor phase at compressor inlet **30** and vapor injection inlet **32**, as described below, and compresses this refrigerant vapor into a high pressure, superheated vapor phase thereby increasing the temperature, enthalpy and pressure of the refrigerant. This hot vapor phase refrigerant discharges at compressor outlet **28** into fluid line **34**, which conveys the vapor to reversing valve **14**. Valve **14** passes this superheated vapor to fluid line **36**, which conveys the vapor to the compressor-side port **38** of load heat exchanger **16**.

Load heat exchanger **16** is in thermal communication with a conditioned space **B**, which may be a residence or other building, for example, and operates to exchange heat Q_1 between the refrigerant and a working fluid and thereby send heat Q_1 to conditioned space **B**. In particular, the superheated refrigerant vapor received at port **38** discharges heat Q_1 to a relatively cooler working fluid circulating through working fluid lines **42** between building **B** and load heat exchanger **16**. The heated working fluid exits at crossflow outlet **38A** of load heat exchanger **16**, carrying heat Q_1 which is subsequently deposited in building **B**. For example, building **B** may have a radiant heat system which extracts heat Q_1 from the working fluid and then sends cooled fluid back to crossflow inlet **40A** of load heat exchanger **16**, where

the working fluid is again allowed to circulate through heat exchanger **16** to absorb heat Q_1 from the hot refrigerant vapor. Other heating systems for building **B** may be used in accordance with the present disclosure, such as forced-air heating systems or any other suitable heat transfer arrangement. Moreover, the refrigerant may transfer heat to a circulating working fluid which deposits heat in building **B**, or warmed working fluid may itself be deposited into building **B** directly, such as hot water being directed into a hot water heater for consumption in building **B**, direct refrigerant-to-air heat transfer (e.g., by blowing air over hot heat exchanger coils into building **B**), and the like.

The removal of heat Q_1 from the refrigerant as it passes through load heat exchanger **16** effects a phase change from superheated vapor (at the compressor-side port **38**) to a partially subcooled liquid (at economizer-side port **40**), which is discharged to fluid line **44** and conveyed to the load-side port **46** of economizer heat exchanger **20**. The refrigerant flows through heat exchanger **20**, which removes heat Q_2 therefrom as described below. Upon discharge from economizer heat exchanger **20** at the source-side port **48**, the full volume of refrigerant flow passes through fluid line **50A** to fluid divider **51**, where a main flow of refrigerant continues toward source heat exchanger **18** via fluid line **50B**, while a portion of the refrigerant is diverted into fluid line **52A** and flows toward economizer expansion valve **24**.

At expansion valve **24**, subcooled liquid refrigerant is allowed to expand into a low-pressure, cool liquid- and vapor mixed-phase state. Pressure sensing line **54A** is fluidly connected to expansion valve **24**, such that the pressure within valve **24** can be monitored remotely, e.g., by controller **70** (further described below). The low-pressure, mixed-phase refrigerant discharged from valve **24** is transmitted through fluid line **52B** to a crossflow inlet **48A** of economizer **20** where it circulates in heat-transfer relationship with the main refrigerant flow until reaching crossflow outlet **46A**. During this circulation, heat Q_2 transfers from the warmer main flow of liquid refrigerant passing from port **46** to port **48** to the low-pressure flow of the economizer portion of refrigerant, such that the refrigerant is warmed to a low-pressure superheated vapor by the time it discharges at outlet **46A**. This superheated vapor is carried by vapor injection fluid line **54B** to vapor injection inlet **32** of compressor **12**.

The transfer of heat Q_2 also serves to further lower the temperature of the subcooled liquid phase refrigerant exiting the source-side port **48**, as compared to the liquid phase refrigerant entering at the load-side port **46**. As noted above, a main flow of this lower-temperature subcooled liquid phase refrigerant passes divider **51** and flows through fluid line **50B** to primary expansion valve **22**. In valve **22**, the sub-cooled liquid is allowed to expand into a low-pressure, cold, mixed liquid/vapor phase. This cold fluid is conveyed via fluid line **56A** to a filter/dryer **26**, which separates entrained liquid from the vapor and discharges the cold liquid and vapor to fluid line **56B**, which conveys the refrigerant to the economizer-side port **60** of source heat exchanger **18**.

The cold mixed-phase refrigerant received at economizer-side port **60** passes through source heat exchanger **18**, receiving heat Q_3 from working fluid circulating through source heat exchanger **18** from source **S**, thereby warming up to a low-pressure, superheated vapor phase refrigerant which is discharged at the valve-side port **62**. Source **S** may be, for example, a geothermal source which is at a consistently warmer temperature than the cold refrigerant received at the economizer-side port **60**. Cooled working fluid is

circulated from crossflow outlet 60A, through working fluid lines 64 circulating through source S where the working fluid is warmed, and back to source heat exchanger 18 at crossflow inlet 62A. The warmed working fluid is then ready to discharge heat Q_3 to the cold refrigerant as noted above.

In an exemplary embodiment, the working fluid circulating through load heat exchanger 16 may be, e.g., water, while the working fluid circulating through source heat exchanger 18 may be, e.g., water, methanol, propylene glycol, or ethylene glycol.

The low-pressure, superheated vapor discharged from the valve-side port 62 of source heat exchanger 18 is conveyed via fluid line 66 to reversing valve 14, where it is allowed to pass to fluid line 68, which in turn conveys the vapor to compressor inlet 30 to be compressed for the next refrigerant cycle.

Turning now to FIG. 2, a cooling mode of air conditioning system 10 is illustrated in which refrigerant flow is substantially reversed from the heating mode of FIG. 1, and the discharge of heated vapor from economizer 20 to compressor 12 is ceased such that vapor injection functionality is operably disabled.

To reverse the refrigerant flow direction from heating to cooling mode, 4-way reversing valve 14 is toggled to the configuration of FIG. 2. Thus, as illustrated, hot superheated vapor phase refrigerant discharged from compressor outlet 28 is conveyed to the valve-side port 62 of source heat exchanger 18 via fluid line 34, valve 14, and fluid line 66. Rather than transferring heat to the conditioned space of building B via load heat exchanger 16 as shown in FIG. 1 and described in detail above, source heat exchanger 18 now serves as a condenser to extract heat from the hot vapor phase refrigerant, and deposit the extracted heat Q_3 at source S by thermal exchange between the refrigerant and the working fluid circulating through fluid lines 64.

Subcooled liquid exits source heat exchanger 18 at the economizer-side port 60 and passes through filter 26 as described above. The subcooled liquid then passes through primary thermal expansion valve 22, where the refrigerant is expanded to a cold vapor/liquid mixture and discharged to fluid line 50B. At fluid divider 51, no refrigerant flow passes to fluid line 52A toward economizer expansion valve 24, but rather, the entire volume of refrigerant passes from line 50B to line 50A and on to economizer 20. Thus, no fluid circulates from crossflow inlet 48A to crossflow outlet 46A of economizer 20, and therefore no substantial heat transfer occurs within economizer heat exchanger 20. Thus, the cold vapor/liquid mixture which enters economizer 20 at the source-side port 48 exits the load-side port 46 with substantially unchanged temperature, pressure and phase.

In order to stop the diversion of refrigerant flow at divider 51 and therefore effectively disable economizer 20, economizer expansion valve 24 may be adjusted to a fully closed position. This prevents fluid flow therethrough, such that no fluid passage through fluid lines 52A, 52B and 54B occurs. In an exemplary embodiment, valve 24 is an electronic expansion valve (EEV) which can be continuously adjusted between fully closed and fully opened positions, as well as any selected intermediate position. Advantageously, the use of an EEV for economizer expansion valve 24 allows controller 70 to control valve 24 automatically according to a programmed set of instructions. As described in detail below, controller 70 may automatically adjust valve 24 to a fully closed, zero-flow position when air conditioning system 10 is toggled from the heating mode to the cooling mode. However, it is contemplated that economizer expansion valve 24 may be a thermostatic expansion valve (TXV)

together with a solenoid operable to separately permit or prevent flow therethrough. The thermostatic expansion valve may change the size of its fluid flow passageway responsive to pressure and/or temperature changes, while the solenoid operates as an open/closed only valve.

Referring still to FIG. 2, the lack of fluid flow through economizer expansion valve 24 also results in a lack of flow through vapor injection fluid line 54B, such that no vapor is injected at vapor injection inlet 32 of compressor 12. Accordingly, the vapor injection functionality provided in the heating mode of FIG. 1 is operably disabled and the cooling mode of FIG. 2 by the closure of expansion valve 24.

The mixed vapor/liquid phase refrigerant discharged at the load-side port 46 of economizer 20 is carried to economizer-side port 40 of load heat exchanger 16 by fluid line 44, where heat Q_1 is transferred to the cool vapor mixture from building B. In particular, cooled working fluid circulates from crossflow outlet 38A, through working fluid lines 42 and into building B, where the working fluid is warmed by the ambient air of building B. This warmed working fluid is carried by working fluid lines 42 back to crossflow inlet 40A of load heat exchanger 16, where the flow of the relatively colder vapor/liquid refrigerant absorbs heat Q_1 , such that the refrigerant is converted to a superheated vapor phase by the time it is discharged at the compressor-side port 38. Fluid line 36 conveys the superheated vapor through valve 14 to fluid line 68, and then to compressor inlet 30, where the low-pressure superheated vapor is again compressed for a new refrigerant cycle.

Advantageously, the disabling of the vapor injection functionality in the cooling mode, while enabling the same in the heating mode, allows efficiency gains to be realized in a reversible heat pump system. In particular, compressor 12 operates with relatively high compression ratios in the heating mode of FIG. 1, in order to provide the requisite heat for conditioning building B by deposit of heat Q_1 therein. Thus, in view of the larger work load borne by compressor 12 during the heating mode, a vapor compression functionality as shown in FIG. 1 and described in detail above provides substantial increases in capacity and efficiency of air conditioning system 10. However, in the cooling mode of FIG. 2, compressor 12 may utilize lower compression ratios between inlet 30 and outlet 28 while still providing adequate removal of heat Q_1 from building B. At these lower compression ratios, vapor injection is unnecessary and that functionality may therefore be disabled without an efficiency penalty. Advantageously, the operable disabling of vapor injection may be accomplished entirely by controller 70 e.g., by issuing a command for economizer expansion valve 24 to fully close when reversing valve 14 to toggle from the heating to the cooling mode.

2. Variable-Speed Scroll Compressor

In an exemplary embodiment, compressor 12 is a variable speed scroll-type compressor. Scroll compressors, also known as spiral compressors, use two interleaving scrolls to pump fluid from an inlet to an outlet, such as by fixing one scroll while the other orbits eccentrically without rotating, thereby trapping and pumping or compressing pockets of fluid between the scrolls. Advantageously, the superheated vapor received at the vapor injection port may be injected to the scroll set at an intermediate point of the compression process. The size and position of these ports can be optimized to ensure maximum benefit and coefficient of performance and capacity for scroll compressor 12 at expected operating conditions for a particular application.

In one exemplary embodiment shown in FIG. 3, compressor 12 includes vapor injection inlet 32 on an outer surface of compressor shell 126, leading to a vapor transfer tube 120 extending into the interior of compressor 12 around scroll 122 to manifold 138. Manifold 138 delivers the vapor to vapor injection outlets 124 via lateral passageway 140 formed in stationary scroll 136. Outlets 124 may be positioned along passageway 140 at any selected location to correspond with a selected wrap of scroll 122. Outlets 124 deliver vapor V within working pockets defined between the scroll wraps which are at an intermediate pressure between the low pressure at inlet 32 (FIG. 1) and the high pressure at outlet 28 (FIG. 1). Thus, superheated vapor flowing from economizer 20 is received at vapor injection inlet 32, and is then delivered via tube 120 and outlets 124 to a desired location among the wraps of scroll 122. Advantageously, the particular location of outlets 124 among the wraps of scroll 122 can be selected for a particular application, in order to provide superheated vapor to scroll 122 at a desired location for maximum efficiency of compressor 12.

Variable speeds used in compressor 12 further allows precise matching of compressor output to the load demanded for a particular application. In the embodiment of FIG. 3, scroll 136 is a fixed scroll while moveable scroll 122 may orbited relative to scroll 136 at a variable speed to provide the variable speed function of compressor 12. In the illustrated reversible embodiment of FIGS. 1 and 2, the variable loads imposed by heating and cooling cycles (as noted above) may be met by varying the speed of compressor 12. Further, the variable-speed operation facilitates a steady ramp up and ramp down as compressor 12 changes speed, such that a refrigerant buffer tank may be kept to a minimal size.

3. Coaxial Heat Exchangers

In an exemplary embodiment, economizer 20 is a coaxial heat exchanger 80, shown in FIG. 4. Coaxial heat exchanger 80 includes outer fluid passageway 82 with a coaxial inner fluid passageway 84 received therewithin, as shown in FIG. 5. The coaxial arrangement of passageways 82 and 84 may form a plurality of coils 86 (FIG. 4) to provide a desired axial extent of passageways 82, 84 while consuming a minimal amount of physical space. Outer passageway 82 includes axial ends 88 which sealingly engage the outer surface of the adjacent inner passageway 84, and include inlet 90 and outlet 92 radially spaced from the outer surface of the main axially extending body of outer passageway 82.

An incoming flow F_1 is received at inlet 90, as best seen in FIG. 5, and proceeds to flow around the outer surface of inner fluid passageway 84 until reaching outlet 92 where it is discharged as outlet flow F_2 . Similarly, an inlet flow F_3 flows into inner fluid passageway 84 at inlet 96, and flows along the opposite axial direction through inner passageway 84 to be discharged at outlet 94 as flow F_4 , while remaining fluidly isolated from the flow through outer passageway 82. This “counter-flow” arrangement, in which the inlet 90 of outer fluid passageway 82 is adjacent the outlet 94 of the inner fluid passageway 84 and vice-versa, promotes maximum heat transfer between the respective working fluids by maximizing the temperature differential throughout the axial extent of coaxial heat exchanger 80. However, in some instances, one of the fluid flows may be reversed so that both working fluids travel along the same direction.

In the exemplary embodiment of FIG. 5, inner fluid passageway 84 may include a plurality of corrugations 98 arranged in a helical threadform-type pattern, which encourages the development of a twisting, turbulent flow through both outer and inner fluid passageways 82, 84. This flow

ensures that the working fluids in passageways 82, 84 remain well mixed to promote thorough heat transfer between the two fluids throughout the axial extent of heat exchanger 80.

Advantageously, employing coaxial heat exchanger 80 for economizer 20 in air conditioning system 10 helps to ensure delivery of sub-cooled liquid to expansion valve 22, while also ensuring that the vapor injection flow through fluid line 54B to vapor injection port 32 (FIG. 1) is always superheated. In particular, the coaxial heat exchanger arrangement shown in FIGS. 4 and 5 provides a large amount of heat transfer between the fluid flows, thereby promoting the provision of pure superheated vapor to the vapor injection port 32 of compressor 12, which may be designed to handle only vapor such as in the case of scroll compressor 12 described above. The heat transfer enabled by economizer 20 also ensures that only subcooled liquid is provided to expansion valve 22, which may operate properly and efficiently (e.g., without “hunting” or erratic adjustment behavior) when pure liquid is delivered.

In a further exemplary embodiment, heat exchanger 80 may be designed to operate using potable water in one or both of passageways 82, 84. For example, coaxial heat exchanger 80 may also be used for load heat exchanger 16, in which the working fluid circulating through working fluid lines 42 to building B may be water designed to be delivered to the end user, such as hot water for a hot water heater which discharges to building appliances. It is also contemplated that source heat exchanger 18 may be a coaxial heat exchanger 80, designed for either potable or non-potable fluid flows.

In some instances, economizer 20 may be formed as flash tank 100, shown in FIG. 6. In this arrangement, a flow F_5 of refrigerant is received at inlet 102 in a mixed phase, such as a partially subcooled refrigerant of the type carried by fluid line 44 shown in FIG. 1. This refrigerant is allowed to expand or “flash” into vapor upon entry into flash tank 100. Saturated vapor 104 rises toward outlet 106, passing through a de-entrainment mesh pad 108 to remove any entrained liquid in vapor 104. This drier, but still saturated vapor 110 flows from outlet 106 to the vapor injection port of a compressor, such as inlet 32 of compressor 12 via fluid line 54B as shown in FIG. 1. Meanwhile, residual liquid 112 collects at the bottom of flash tank 100, the level of which is measured by fluid level measuring device 114. Depending on the measured level of liquid 112, a control valve 116 connected at liquid outlet 118 may be opened (to lower the level) or closed (to allow further liquid accumulation). The sub-cooled liquid 112 may be discharged to an expansion valve, such as expansion valve 22 via fluid lines 50A, 50B.

However, the provision of saturated vapor 110 to a vapor injection port of a compressor is not optimal, because in some cases such vapor may include droplets of liquid refrigerant, for which the compressor, such as scroll compressor 12, is not designed. Further, the level of liquid 112 within flash tank 100 must be controlled within a given range, and is influenced by the particular refrigerant properties received at flow F_5 , as well as the volume of flow. Thus, flash tank 100 must be sized according to other system parameters of air conditioning system 10 in order to work properly, and the working parameters of system 10 may only be changed within a certain range without overwhelming the capacities of flash tank 100. In order to provide flexibility for reversible functionality the exemplary embodiment of air conditioning system 10 shown in FIGS. 1 and 2 utilizes coaxial heat exchanger 80 for economizer 20, rather than flash tank 100.

4. Transcritical Refrigerant

In an exemplary embodiment, the refrigerant flow used for the thermal cycle of air conditioning system **10** is R410A refrigerant. In air conditioning system **10**, R410A may be used in a transcritical cycle, i.e., the refrigerant may be present in both sub-critical and super-critical states at different points along its fluid path.

For purposes of the present disclosure, a super-critical fluid is a fluid having a temperature and pressure above its critical point, at which distinct liquid and gas phases do not exist. For example, the “vapor/liquid mixture” referred to above with respect to the heating and cooling cycles shown in FIGS. **1** and **2** may be super-critical fluids. Sub-critical fluids, on the other hand, are fluids in which distinct liquid and gas phases do exist, such as subcooled liquid and superheated vapor as described in detail above with respect to the heating and cooling cycles of FIGS. **1** and **2** respectively.

Advantageously, R410A refrigerant can traverse sub-critical and super-critical states without itself changing phase, such that a higher temperature refrigerant may be utilized for more effective heat transfer at various stages of air conditioning system **10**. Moreover, R410A is also widely used in homes and buildings for primary heating/cooling needs in the United States as well as elsewhere in the world, and is readily commercially available in sufficient quantity for small- or large-scale heating/cooling needs for a reasonable price. R410A is also generally accepted under local, state, and federal codes.

In some applications in accordance with the present disclosure, other refrigerant candidates may include R134a, R32, R1234ze, or blends of any of the previously mentioned refrigerants.

5. Control and Operation

In operation, controller **70** is electrically connected to compressor **12**, 4-way reversing valve **14**, economizer expansion valve **24** and primary expansion valve **22**, as shown in FIGS. **1** and **2**. In the heating mode (FIG. **1**), controller **70** toggles 4-way reversing valve **14** into the illustrated configuration, opens economizer expansion valve **24** to an appropriate fluid flow capacity, and adjusts primary expansion valve **22** to produce a desired vapor mixture carried by fluid lines **56A**, **56B** from the expected sub-cooled liquid arriving from fluid line **50B**.

Controller **70** activates compressor **12**, which sets the heating cycle in motion by compelling refrigerant to pass through the various functional structures of air conditioning system **10** to effect heating in building B, as described in detail above. In an exemplary embodiment, controller **70** receives signals indicative of fluid pressures within expansion valves **22**, **24**, as measured by pressure sensing lines **58**, **54A**, respectively. Controller **70** includes a comparator which compares the pressures within pressure sensing lines **58**, **54A** of valves **22**, **24**, respectively, against a desired pressure for a particular application. This comparison results in a disparity between the desired and actual pressure, which is then compared against a threshold acceptable disparity. When the actual disparity is beyond the threshold disparity, controller **70** adjusts the fluid flow through valves **22**, **24** and/or the speed of compressor **12** in order to bring the pressure within pressure sensing lines **58**, **54A** to a level within the desired disparity.

When it is desired to switch from the heating mode of FIG. **1** to the cooling mode of FIG. **2**, controller **70** toggles 4-way reversing valve **14** from the configuration of FIG. **1** to the configuration of FIG. **2**. In addition, controller **70** adjusts economizer expansion valve **24** to a fully closed

position, thereby operably disabling the vapor injection feature used in the heating mode, as described in detail above. Primary expansion valve **22** may also be adjusted to the differing demands of receiving sub-cooled liquid from fluid line **56A** and discharging a vapor mixture to fluid lines **50B**, as described above.

Controller **70** may then activate compressor **12** in order to compel the refrigerant throughout the refrigerant circuit shown in FIG. **2** and effect cooling of building B as described above. As with the heating mode described above, controller **70** may adjust the speed of compressor **12** and/or the flow characteristics through valve **22** in order to maintain the pressure within pressure sensing line **58** in an acceptable range. Generally speaking, the desired pressure within valve **22** and line **58** is lower in the cooling mode of air conditioning system **10** as compared to the heating mode thereof. Therefore, compressor **12** is generally controlled by controller **70** to operate at a slower and/or lower power state in the cooling mode as compared to the heating mode.

6. Applications.

The present system may be used in the following particularized applications.

In an exemplary embodiment, air conditioning system **10** may be used in a geothermal system, in which source heat exchanger **18** is in heat exchange relationship with a ground source/loop **64** as a heat source/heat sink S.

Air conditioning system **10** may also be used for hot water heating for hydronic applications, such as residential or business heating systems which use water as a heat-transfer medium for heating the air inside a building. Such systems include radiant-heat applications, for example. In the exemplary embodiment of FIGS. **1** and **2**, working fluid lines **42** may carry hot water to building B, deposit heat Q_1 therein, and recirculate to load heat exchanger **16** to be reheated.

For example, an exemplary geothermal application of air conditioning system **10** utilized with forced-air type air conditioning is illustrated in FIG. **7**. Air conditioning system **10** is contained within a single housing **128**, as shown, which also includes air movers (not shown) for inducing air flow F through ducts **42** (in the forced-air context of FIG. **7**, ducts are the working fluid conduits **42** of FIG. **1** and air is the working fluid). Source S is a ground source, such as an underground formation of soil, rock, water, and the like. In the cooling mode, heat Q_3 is deposited into the underground formation by warm working fluid circulating through fluid lines **64**, and withdrawn from building B as heat Q_1 via ducts **42**. Conversely, in the heating mode, heat Q_3 is withdrawn from the underground formation by cool working fluid circulating through fluid lines **64**, and deposited into building B as heat Q_1 via ducts **42**.

As noted above and illustrated in FIG. **7**, air conditioning system **10** may also be used for domestic or commercial hot water heating. Such systems convey hot working fluid from air conditioning system **10** (e.g., from load heat exchanger **16**) through hot water line **132** to a water heater **130** which may be located, e.g., in building B. Cool water is returned to air conditioning system **10** (e.g., back to load heat exchanger **16**) via a cool water line **134** to be reheated.

While this disclosure has been described as having exemplary designs, the present disclosure can be further modified within the spirit and scope of this disclosure. This application is therefore intended to cover any variations, uses, or adaptations of the disclosure using its general principles. Further, this application is intended to cover such departures from the present disclosure as come within known or customary practice in the art to which this disclosure pertains and which fall within the limits of the appended claims.

What is claimed is:

1. A reversible heat pump system housed in a housing for heating and cooling a space, comprising:

a refrigerant circuit through which refrigerant is configured to flow;

a variable speed scroll compressor disposed on the refrigerant circuit, the compressor including a compressor inlet, a compressor outlet, and a vapor injection inlet disposed between the compressor inlet and the compressor outlet;

a liquid-to-liquid coaxial counterflow load heat exchanger disposed on the refrigerant circuit to exchange heat between the refrigerant and either a cooling load or a heating load;

a liquid-to-liquid coaxial counterflow source heat exchanger disposed on the refrigerant circuit to exchange heat between the refrigerant and a source;

a reversing valve disposed on the refrigerant circuit between the compressor and the load and source heat exchangers and selectable to effect a heating mode and a cooling mode, wherein in the heating mode the reversing valve routes the refrigerant from the compressor outlet to the load heat exchanger and routes the refrigerant from the source heat exchanger to the compressor inlet, wherein in the cooling mode the reversing valve routes the refrigerant from the compressor outlet to the source heat exchanger and routes the refrigerant from the load heat exchanger to the compressor inlet;

a diverter disposed on the refrigerant circuit between the load heat exchanger and the source heat exchanger, the diverter configured to selectively divert a portion of the refrigerant to an economizer circuit when the heat pump is in the heating mode and none of the refrigerant when the heat pump is in the cooling mode, wherein the economizer circuit includes

a coaxial counterflow economizer heat exchanger configured to exchange heat between the refrigerant diverted to the economizer circuit and the refrigerant in the refrigerant circuit to create superheated refrigerant vapor for injection into the vapor injection inlet, and

an electronic economizer expansion valve (EEEV) disposed between the diverter and the economizer heat exchanger, the EEEV configured to be continuously adjustable between fully open and fully closed positions to selectively meter and expand the diverted refrigerant when the heat pump is in the heating mode and to selectively cease diversion of the refrigerant to the economizer circuit when the heat pump is in the cooling mode; and

an electronic primary expansion valve (EPEV) disposed on the refrigerant circuit between the diverter and the source heat exchanger to selectively meter the refrigerant discharged from the economizer heat exchanger to the source heat exchanger when the heat pump is in the heating mode and the economizer circuit is active, and to selectively meter the refrigerant discharged from the source heat exchanger to the economizer heat exchanger when the heat pump is in the cooling mode and the economizer circuit is inactive,

wherein in the heating mode, the EPEV receives the refrigerant from the economizer heat exchanger and discharges the refrigerant to the source heat exchanger; and

in the cooling mode, the EPEV receives the refrigerant from the source heat exchanger and discharges the refrigerant to the economizer heat exchanger.

2. The reversible heat pump system of claim 1, including a controller configured to control the EEEV to meter the diverted refrigerant according to a programmed set of instructions.

3. The reversible heat pump system of claim 2, wherein the controller is operably connected to the reversing valve and the EEEV, the controller operable to:

toggle the reversing valve into the heating mode and adjustably open the EEEV when the reversible heat pump system is called upon to deposit heat into a conditioned space; and

toggle the reversing valve into the cooling mode and close the EEEV to a fully closed position when the reversible heat pump system is called upon to withdraw heat from the conditioned space.

4. The reversible heat pump system of claim 1, wherein the coaxial counterflow economizer heat exchanger comprises

a first flow path through which the refrigerant in the refrigerant circuit passes; and

a second flow path through which the refrigerant diverted to the economizer circuit passes, the second flow path coaxial with, but fluidly isolated from, the first flow path such that the first flow path is in heat exchange relationship with the second flow path.

5. The reversible heat pump system of claim 1, wherein at least one of the load heat exchanger and the source heat exchanger comprises

a first flow path through which the refrigerant passes; and

a second flow path through which a first or second working fluid passes, respectively, the second flow path coaxial with, but fluidly isolated from, the first flow path such that the first flow path is in heat exchange relationship with the second flow path.

6. The reversible heat pump system of claim 1, further comprising a refrigerant filter/dryer disposed on the refrigerant circuit between the source heat exchanger and the EPEV.

7. The reversible heat pump system of claim 1, further comprising

a compressor inlet pressure sensor configured to detect refrigerant pressure at the compressor inlet; and

a controller operably connected to the compressor, the EPEV, and the compressor inlet pressure sensor, wherein the controller is operable to

compare a compressor inlet pressure indicated by the compressor inlet pressure sensor to a desired compressor inlet pressure to compute a primary pressure difference, and

if the primary pressure difference is beyond a threshold amount, adjust at least one of a speed of the compressor and a flow rate of the refrigerant through the EPEV to return the primary pressure difference to an amount less than the threshold amount.

8. The reversible heat pump system of claim 7, further comprising a vapor injection pressure sensor configured to detect refrigerant pressure at the vapor injection inlet, wherein the controller is operably connected to the EEEV and to the vapor injection pressure sensor and is operable in the heating mode to

compare a vapor injection inlet pressure indicated by the vapor injection pressure sensor to a desired vapor injection inlet pressure to compute an economizer pressure difference, and

if the economizer pressure difference is beyond a threshold amount, adjust at least one of the speed of the compressor and a flow rate of the diverted refrigerant

13

through the EEEV to return the economizer pressure difference to an amount less than the threshold amount.

9. The reversible heat pump system of claim 1, wherein the refrigerant is R410A and the heat pump system operates the refrigerant in sub-critical and super-critical states.

10. The reversible heat pump system of claim 1, wherein the source is a geothermal source, and a working fluid circulates between the source heat exchanger and the geothermal source to exchange heat between the refrigerant and the geothermal source.

11. A method of controlling a reversible heat pump system housed in a housing, the method comprising:

toggling a reversing valve into one of a heating mode or a cooling mode, the reversing valve being disposed on a refrigerant circuit between a variable speed scroll compressor disposed on the refrigerant circuit, a liquid-to-liquid coaxial counterflow load heat exchanger disposed on the refrigerant circuit to exchange heat between a refrigerant and either a heating load or a cooling mode, and a liquid-to-liquid coaxial counterflow source heat exchanger disposed on the refrigerant circuit in a heat exchanging arrangement with a source, wherein

in the heating mode, the reversing valve routes the refrigerant from a compressor outlet of the compressor to the load heat exchanger and routes refrigerant from the source heat exchanger to a compressor inlet of the compressor, and in the cooling mode, the reversing valve routes the refrigerant from the compressor outlet to the source heat exchanger and routes the refrigerant from the load heat exchanger to the compressor inlet;

controlling an electronic economizer expansion valve (EEEV) configured to be continuously adjustable between fully open and fully closed positions to selectively divert a portion of refrigerant from the refrigerant circuit to a coaxial counterflow economizer heat exchanger, the EEEV being disposed on an economizer circuit between a diverter and the coaxial counterflow economizer heat exchanger, the diverter being disposed on the refrigerant circuit, the coaxial counterflow economizer heat exchanger being configured to exchange heat between the refrigerant diverted to the economizer circuit and the refrigerant in the refrigerant circuit to create superheated refrigerant vapor for injection into a vapor injection inlet of the compressor, including

in the heating mode, adjusting the EEEV to meter and expand the diverted refrigerant and in the cooling mode, fully closing the EEEV to cease diversion of the refrigerant; and

controlling a speed of the compressor to circulate the refrigerant through the load heat exchanger, the economizer heat exchanger, the source heat exchanger, and an electronic primary expansion valve (EPEV) disposed on the refrigerant circuit between the diverter and the source heat exchanger to match compressor output to a heating load and a cooling load, including

14

in the heating mode, metering the refrigerant discharged from an active economizer heat exchanger to the source heat exchanger by the EPEV, and in the cooling mode, metering the refrigerant discharged from the source heat exchanger to an inactive economizer heat exchanger by the EPEV.

12. The method of claim 11, wherein toggling the reversing valve, controlling the EEEV, and controlling the speed of the compressor are performed by an electronic controller for the heating mode and for the cooling mode.

13. The method of claim 12, wherein, in the heating mode: the controller compares a pressure of a vapor injection line with a desired economizer pressure to generate a pressure differential;

the controller compares the pressure differential with a predetermined threshold pressure differential; and the controller adjusts at least one of the speed of the compressor and a flow rate of the diverted refrigerant when the pressure differential is outside the predetermined threshold pressure differential.

14. The method of claim 12, wherein in the heating mode and in the cooling mode the controller compares a pressure in the refrigerant circuit between the reversing valve and the compressor inlet with a desired compressor inlet pressure to generate a pressure differential;

the controller compares the pressure differential with a predetermined threshold pressure differential; and the controller adjusts at least one of the speed of the compressor and a flow rate of the refrigerant through the EPEV when the pressure differential is outside the predetermined threshold pressure differential.

15. The method of claim 12, wherein, in the heating mode, the controller controls at least one of the speed of the compressor, a flow rate of the refrigerant through the EPEV, and a flow rate of the diverted refrigerant through the EEEV to maintain the refrigerant in a mixed liquid-and-vapor phase state between the EEEV and the economizer heat exchanger and between the EPEV and the source heat exchanger.

16. The method of claim 12, wherein, in the cooling mode, the controller controls at least one of the speed of the compressor and a flow rate of the refrigerant through the EPEV to maintain the refrigerant in a mixed liquid-and-vapor phase state between the EPEV and the load heat exchanger.

17. The method of claim 12, wherein, in the heating mode, the controller controls at least one of the speed of the compressor, a flow rate of the refrigerant through the EPEV, and a flow rate of the refrigerant through the EEEV to maintain the refrigerant in a superheated vapor phase between the load heat exchanger and the compressor, and to maintain the refrigerant in a subcooled liquid phase between the economizer heat exchanger and the EPEV.

18. The reversible heat pump system of claim 7, wherein the controller controls the compressor to operate at a slower speed in the cooling mode than in the heating mode.

19. The reversible heat pump system of claim 1, wherein the load heat exchanger heats or cools potable water.

* * * * *

UNITED STATES PATENT AND TRADEMARK OFFICE
CERTIFICATE OF CORRECTION

PATENT NO. : 10,119,738 B2
APPLICATION NO. : 14/862762
DATED : November 6, 2018
INVENTOR(S) : Timothy A. Hammond and Robert R. Brown

Page 1 of 1

It is certified that error appears in the above-identified patent and that said Letters Patent is hereby corrected as shown below:

In the Claims

Column 11, Line 8, "infection" should be --injection--

Column 13, Line 28, "routes refrigerant" should be --routes the refrigerant--

Signed and Sealed this
Twelfth Day of February, 2019



Andrei Iancu
Director of the United States Patent and Trademark Office