



US010113830B2

(12) **United States Patent**  
**Monveldt et al.**

(10) **Patent No.:** **US 10,113,830 B2**  
(45) **Date of Patent:** **Oct. 30, 2018**

(54) **PUMP-ACTION FIREARM WITH BOLT CARRIER LOCKING MECHANISM AND FOLDING BUTT STOCK**

(71) Applicant: **Troy Industries, Inc.**, West Springfield, MA (US)

(72) Inventors: **Sergey Monveldt**, South Hadley, MA (US); **Stephen P. Troy**, West Springfield, MA (US); **David Hewes**, Chesterfield, MA (US); **James P. Demaree**, Avon, CT (US)

(73) Assignee: **TROY INDUSTRIES, INC.**, West Springfield, MA (US)

(\* ) Notice: Subject to any disclaimer, the term of this patent is extended or adjusted under 35 U.S.C. 154(b) by 0 days.

(21) Appl. No.: **15/162,571**

(22) Filed: **May 23, 2016**

(65) **Prior Publication Data**

US 2016/0349001 A1 Dec. 1, 2016

**Related U.S. Application Data**

(62) Division of application No. 14/284,376, filed on May 21, 2014, now Pat. No. 9,347,737.

(Continued)

(51) **Int. Cl.**

**F41C 23/16** (2006.01)

**F41C 23/04** (2006.01)

(Continued)

(52) **U.S. Cl.**

CPC ..... **F41C 23/04** (2013.01); **F41C 7/02** (2013.01); **F41A 3/38** (2013.01); **F41A 3/44** (2013.01)

(58) **Field of Classification Search**

CPC .... **F41A 3/72**; **F41A 3/66**; **F41C 23/04**; **F41C 23/16**; **F41G 11/003**

(Continued)

(56) **References Cited**

U.S. PATENT DOCUMENTS

2,400,349 A \* 5/1946 Haberstump ..... F41C 23/04  
42/72  
2,405,758 A \* 8/1946 Sampson ..... F41C 23/04  
42/72

(Continued)

FOREIGN PATENT DOCUMENTS

DE 102013202842 8/2013  
WO 2010009725 1/2010  
WO 2012001287 1/2012

OTHER PUBLICATIONS

International Search Report and Written Opinion dated Sep. 30, 2015 in corresponding PCT Patent Application No. PCT/US14/62969.

(Continued)

*Primary Examiner* — Michael D David

(74) *Attorney, Agent, or Firm* — Grossman, Tucker, Perreault & Pfeleger, PLLC

(57) **ABSTRACT**

A butt stock for a firearm including the butt stock arrangeable in a first configuration to fold toward a first side of a receiver of the firearm into a first folded position along the first side of the receiver, and unfoldable away from the first side of the receiver of the firearm into an unfolded position rearward of the receiver; and the butt stock arrangeable in a second configuration to fold toward a second side of the receiver of the firearm into a second folded position along the second side of the receiver, and unfoldable away from the second side of the receiver of the firearm into the unfolded position rearward of the receiver.

**12 Claims, 13 Drawing Sheets**

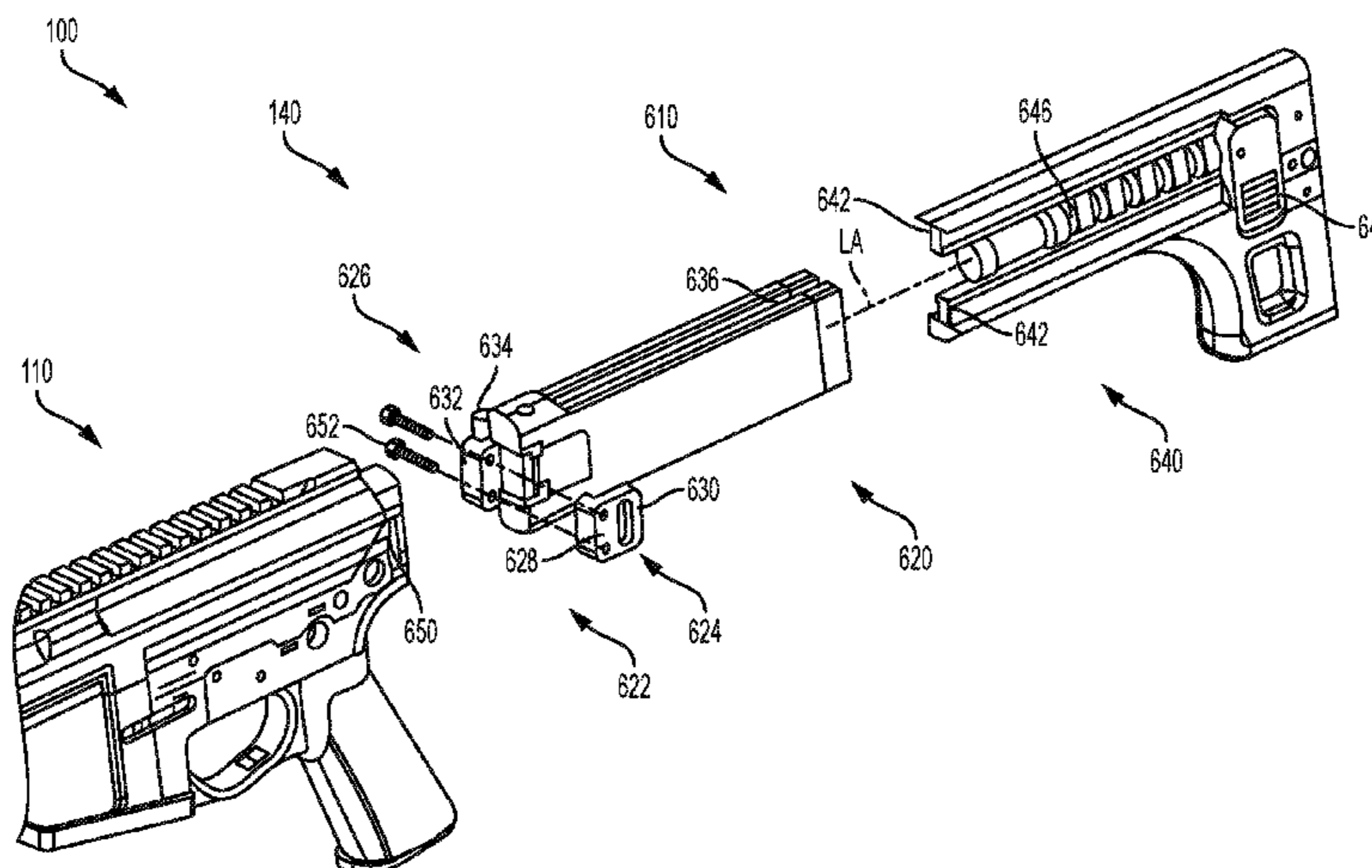

**Related U.S. Application Data**

- (60) Provisional application No. 61/897,170, filed on Oct. 29, 2013.
- (51) **Int. Cl.**  
*F41C 7/02* (2006.01)  
*F41A 3/38* (2006.01)  
*F41A 3/44* (2006.01)
- (58) **Field of Classification Search**  
 USPC ..... 42/16, 73, 84, 71.01, 72, 75.01; 89/193, 89/191.02  
 See application file for complete search history.

(56) **References Cited**

U.S. PATENT DOCUMENTS

2,628,536 A \* 2/1953 Schaich ..... F41A 3/26  
 42/69.02

2,861,374 A 11/1958 Hampton

3,798,819 A \* 3/1974 Hillberg ..... F41C 23/00  
 42/71.01

4,044,487 A 8/1977 Hutton

4,867,039 A 9/1989 Dobbins

4,905,395 A 3/1990 Wagner

5,068,992 A 12/1991 Velezis

6,490,822 B1 12/2002 Swan

6,671,990 B1 1/2004 Booth

6,782,652 B1 8/2004 Erickson

6,782,791 B2 8/2004 Moore

7,337,574 B2 3/2008 Crandall

7,493,718 B2 \* 2/2009 Gorzen ..... F41A 3/10  
 42/42.02

7,610,844 B2 11/2009 Kuczynko

7,634,959 B2 12/2009 Frickey

7,661,220 B2 2/2010 Crandall

7,775,150 B2 8/2010 Hochstrate

7,934,447 B2 5/2011 Kuczynko

7,938,055 B2 5/2011 Hochstrate

8,117,958 B2 2/2012 Hochstrate

8,393,107 B2 3/2013 Brown

8,505,433 B2 8/2013 Hochstrate

8,726,557 B2 5/2014 Stone

8,783,160 B2 7/2014 Hochstrate

8,943,948 B2 2/2015 Kuczynko

9,347,737 B2 5/2016 Troy et al.

9,739,565 B2 \* 8/2017 Kielsmeier ..... F41C 23/04

9,851,175 B2 \* 12/2017 Leasure ..... F41C 23/16

2006/0065112 A1 3/2006 Kuczynko

2006/0260169 A1 11/2006 Samson et al.

2007/0033851 A1 2/2007 Hochstrate

2007/0199225 A1 8/2007 Haugen

2007/0199435 A1 8/2007 Hochstrate

2010/0095834 A1 4/2010 Kuczynko

2010/0300277 A1 12/2010 Hochstrate

2010/0319231 A1 12/2010 Stone

2011/0107644 A1 5/2011 Faifer

2011/0225865 A1 9/2011 Williams

2011/0247254 A1 10/2011 Barnes

2011/0265640 A1 11/2011 Kuczynko

2011/0275435 A1 11/2011 Torre et al.

2011/0283582 A1 11/2011 Hunter et al.

2012/0137561 A1 \* 6/2012 Ludlow ..... F41C 23/04  
 42/75.03

2012/0137562 A1 \* 6/2012 Langevin ..... F41C 23/04  
 42/75.03

2012/0137872 A1 6/2012 Crommett

2012/0204466 A1 8/2012 Bayne

2012/0297970 A1 11/2012 Langevin et al.

2013/0212920 A1 \* 8/2013 Law ..... F41C 23/14  
 42/75.03

2014/0311004 A1 10/2014 Barrett

2015/0113848 A1 \* 4/2015 Monveldt ..... F41C 7/02  
 42/16

OTHER PUBLICATIONS

European Extended Search Report dated Apr. 11, 2017 in connection with European Patent Application No. 14881033.6.

Extended European Search Report from related Application No. 18 158 480.6, dated May 4, 2018.

Fab Defense: "Fab Defense 2012", Mishmar HaShiva Israel, Sep. 19, 2011 (Sep. 19, 2011), XP055472708, Retrieved from the Internet: URL: <https://www.fab-defense.com/download/Fab-catalog-2012.pdf> (retrieved on May 4, 2018), 39 pages.

\* cited by examiner

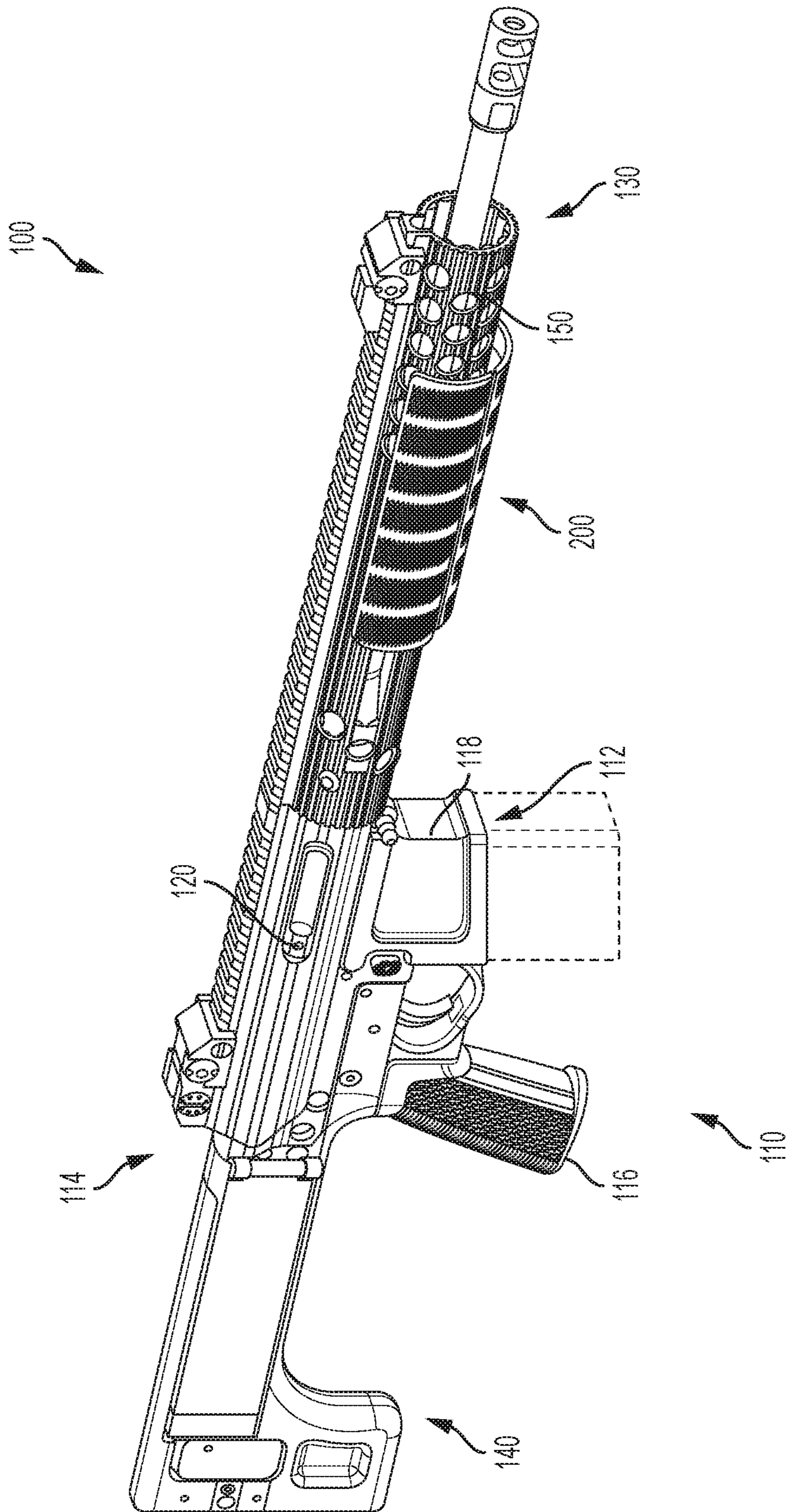

FIG. 1

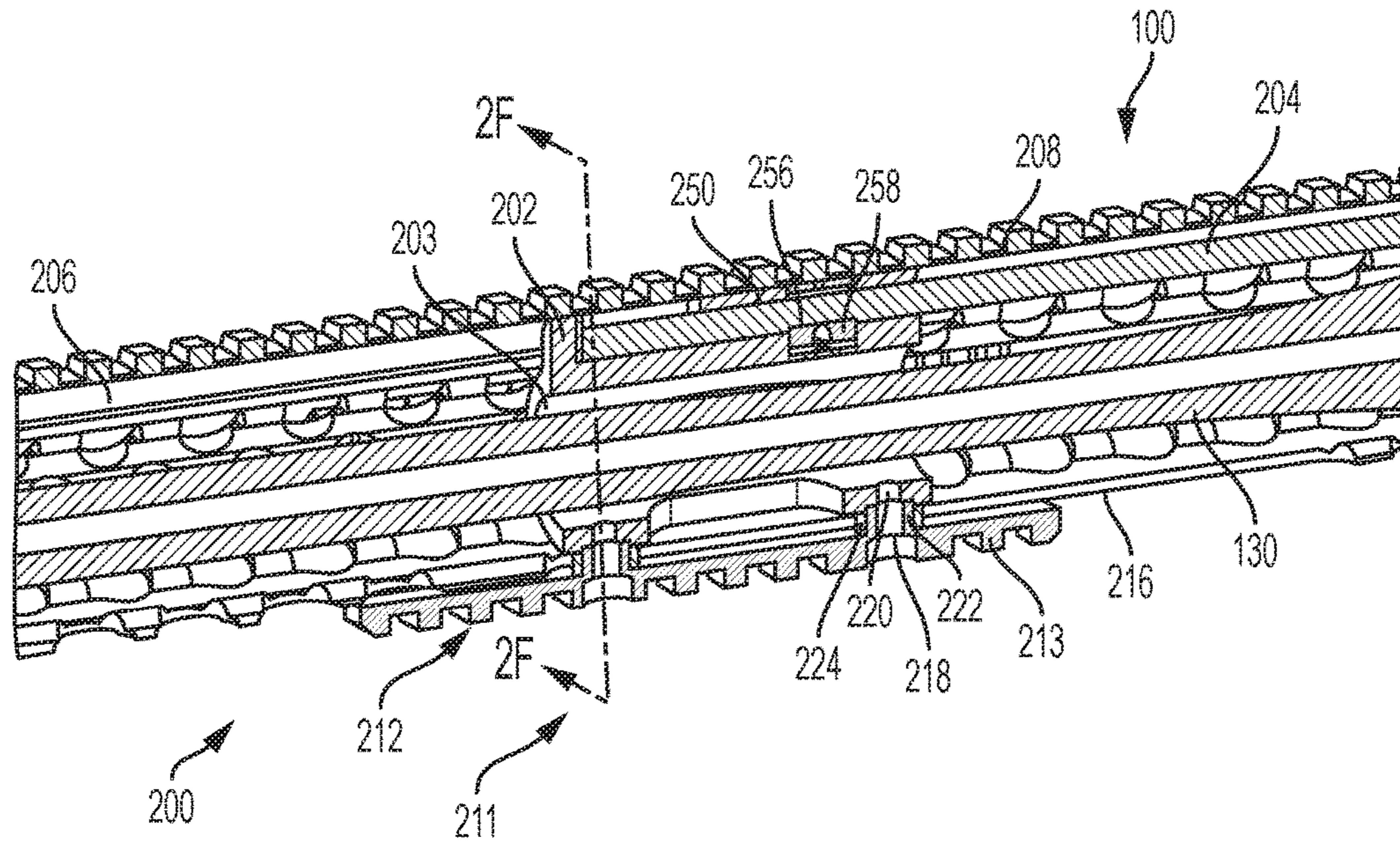

FIG. 2A

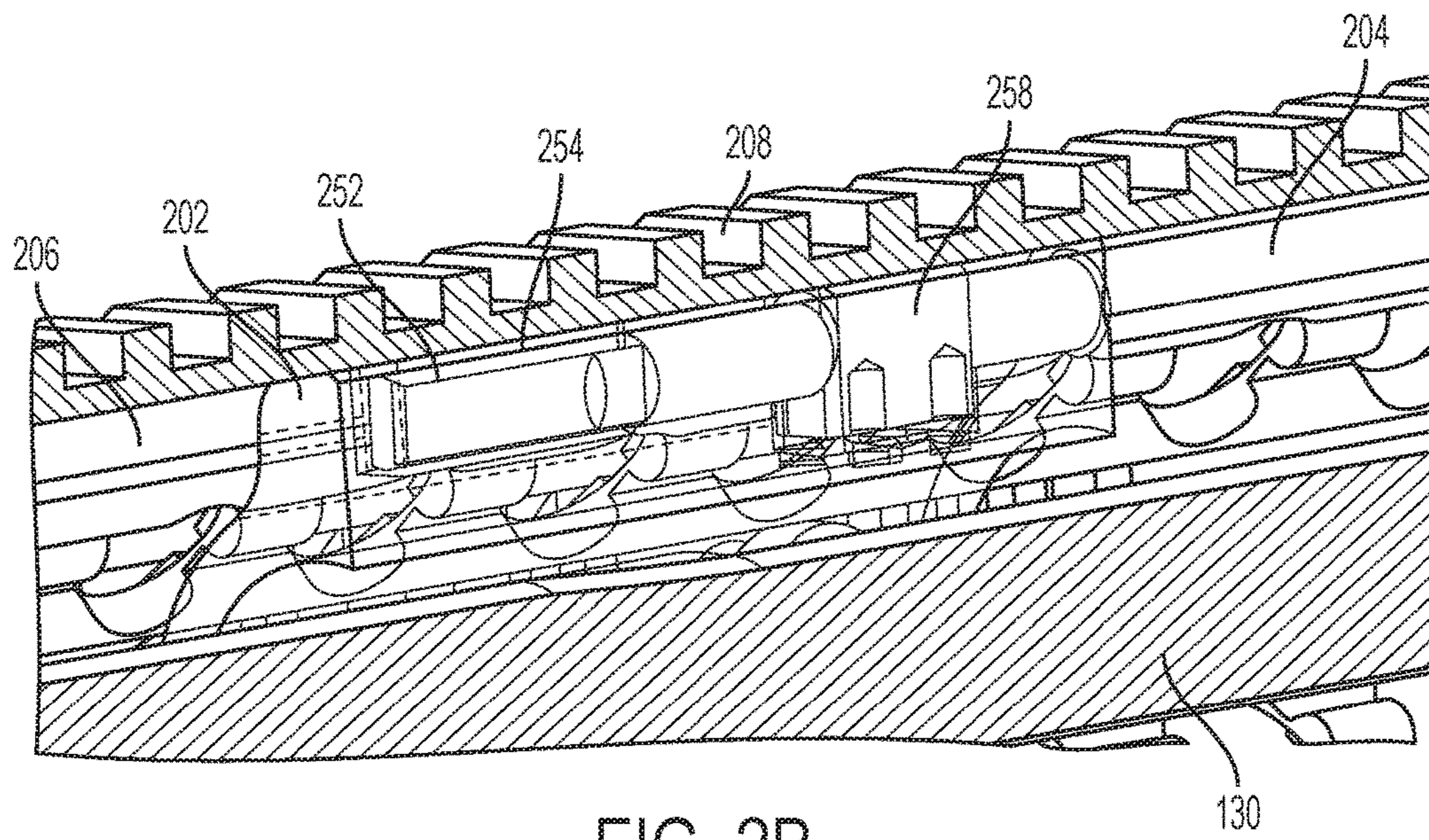
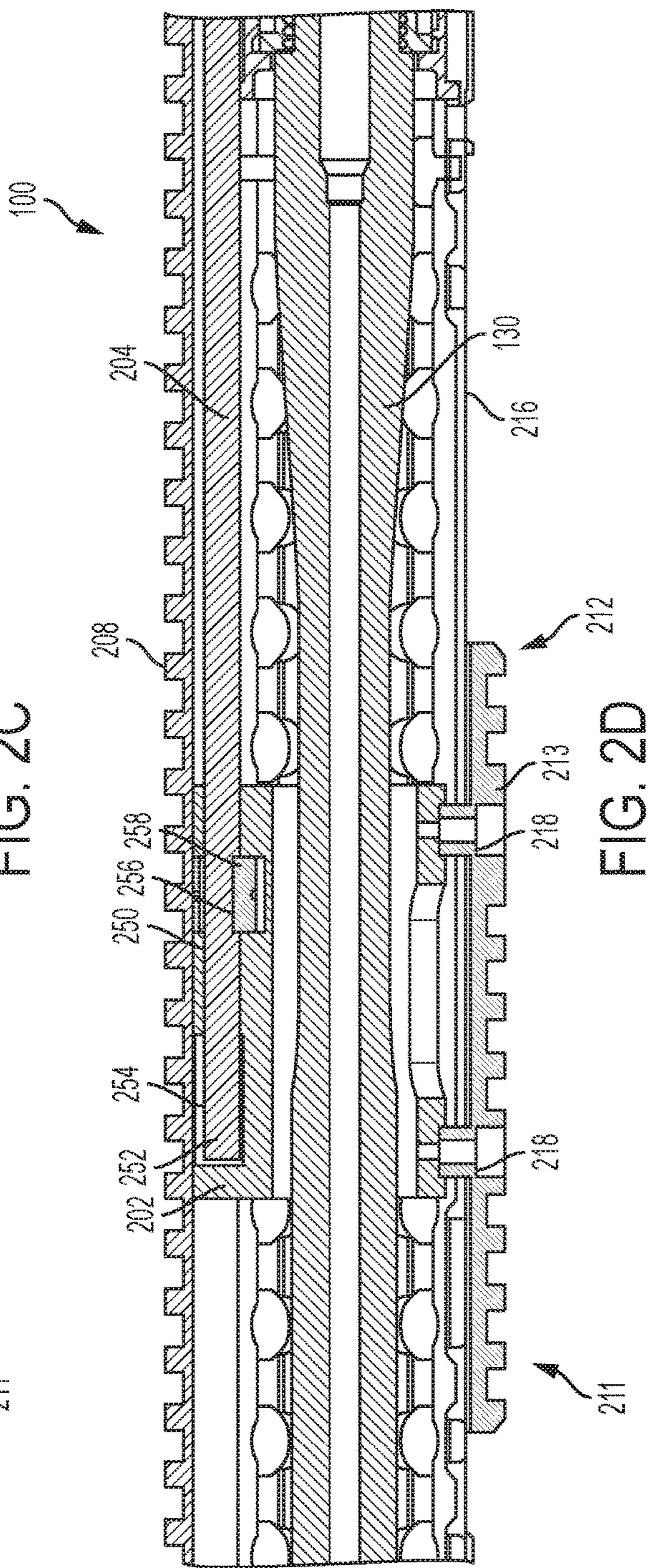
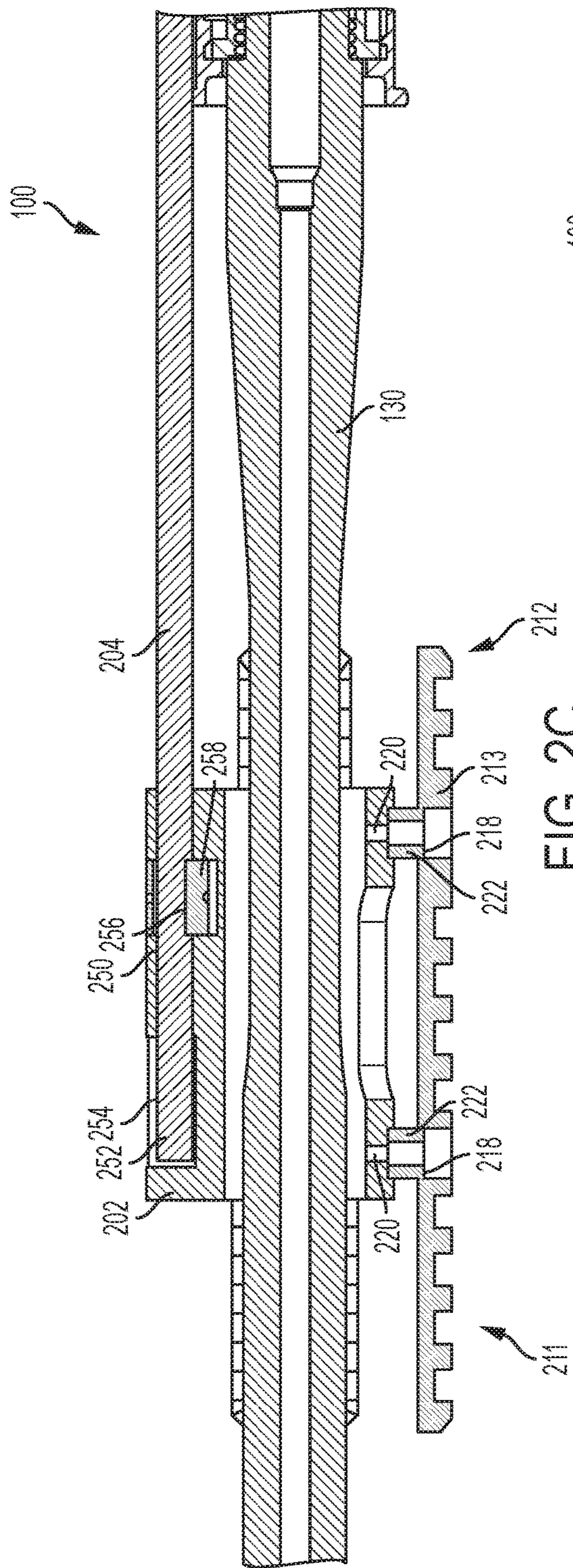

FIG. 2B



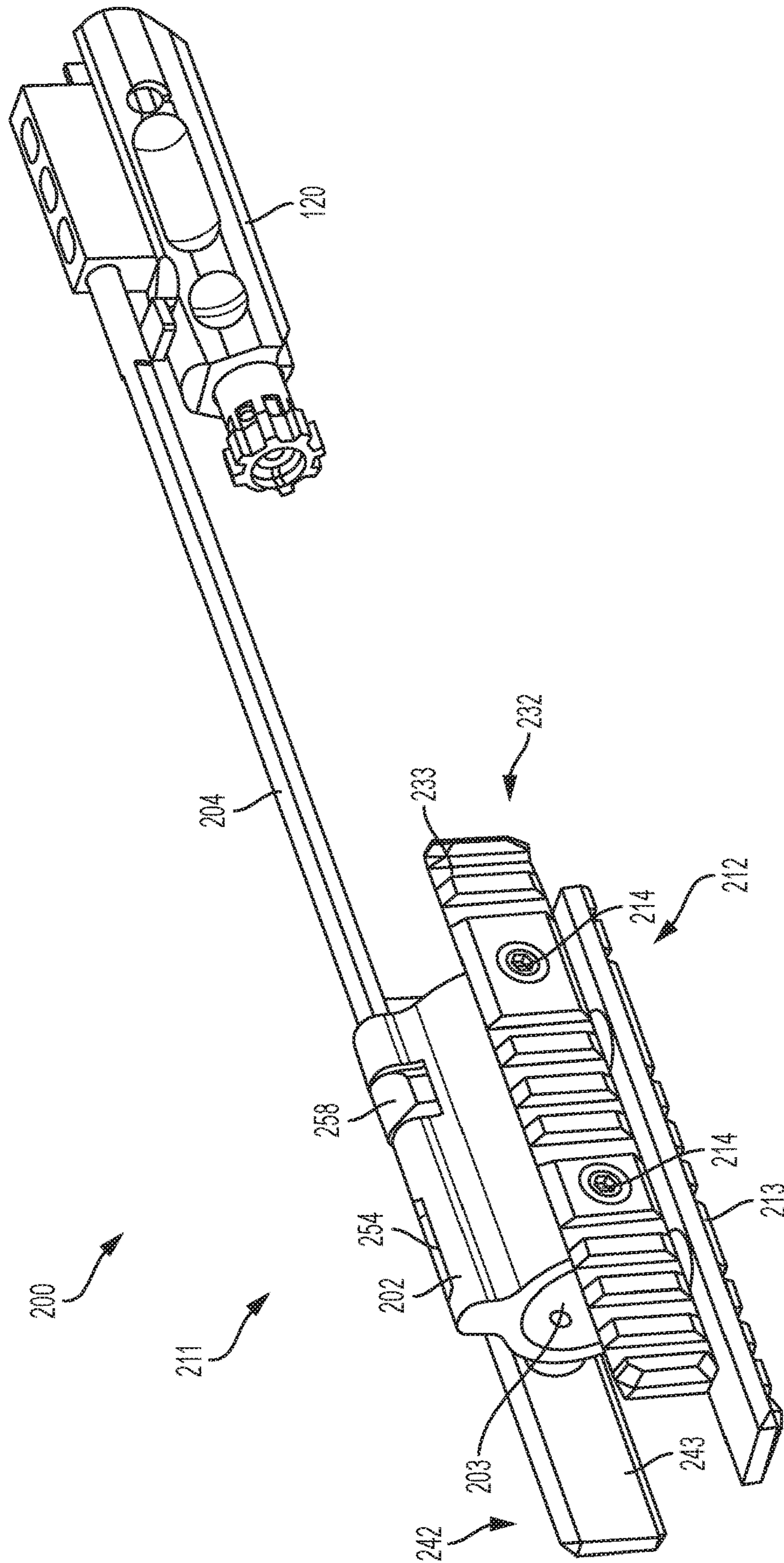

FIG. 2E

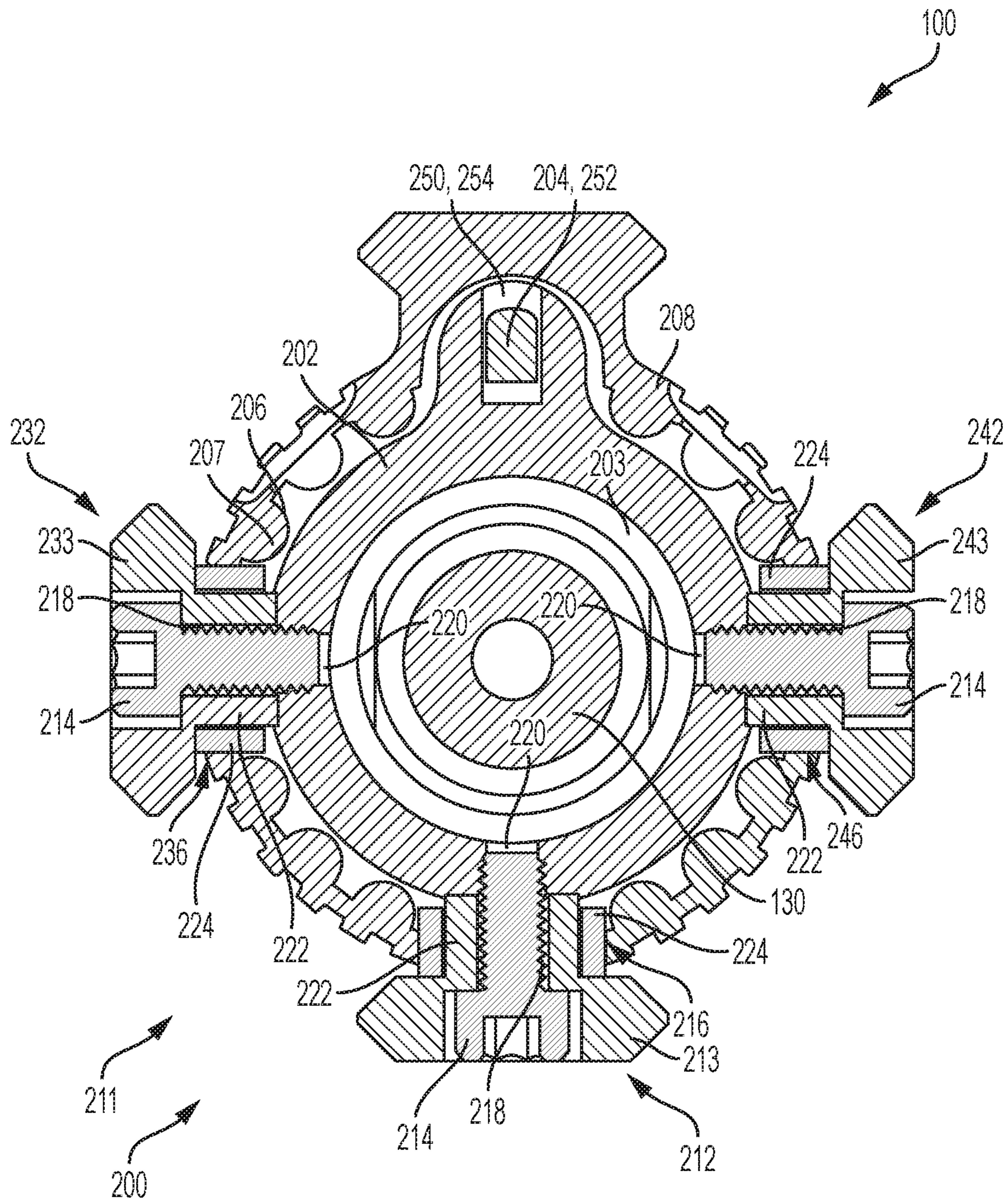

FIG. 2F

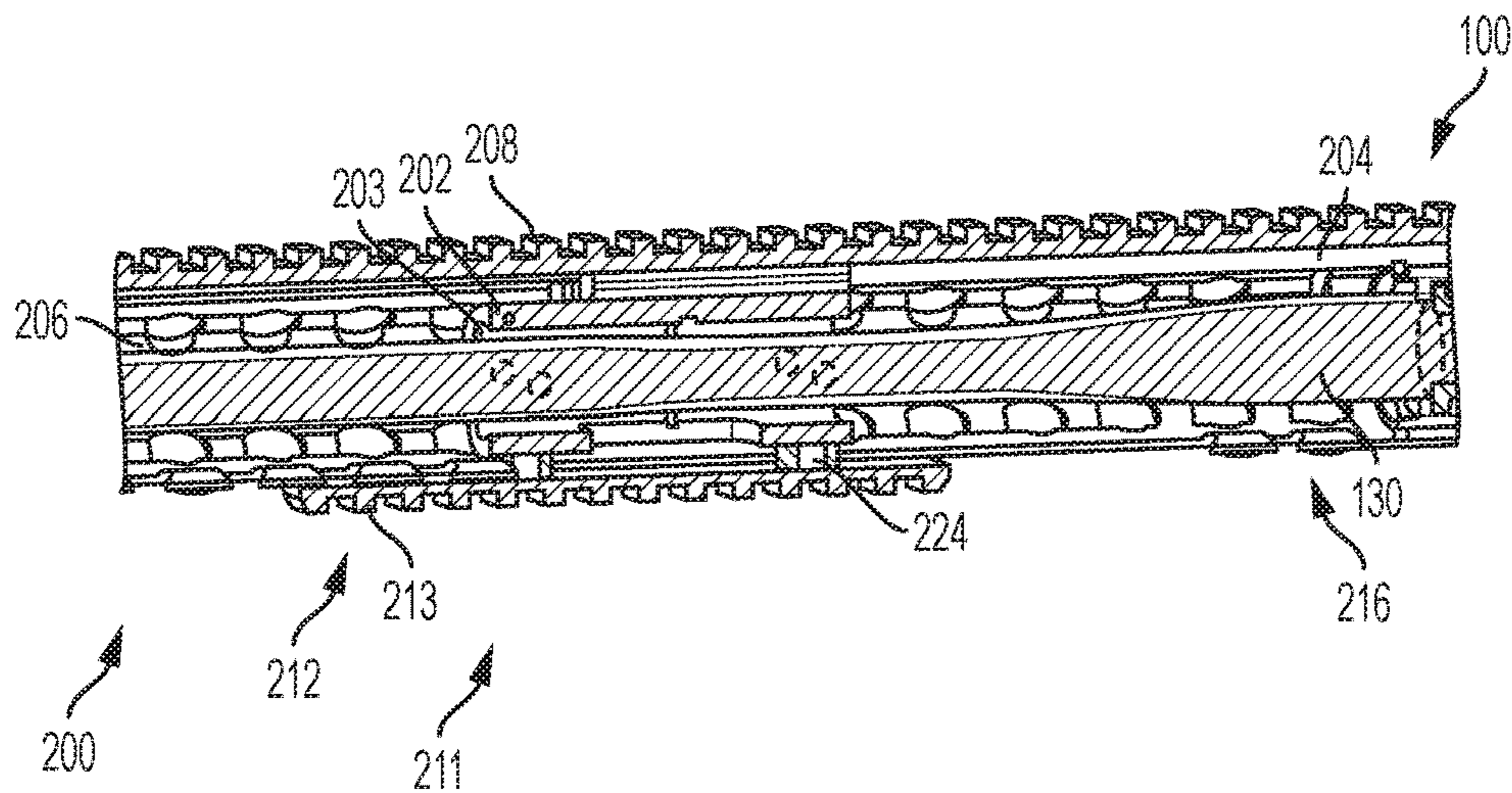

FIG. 3A

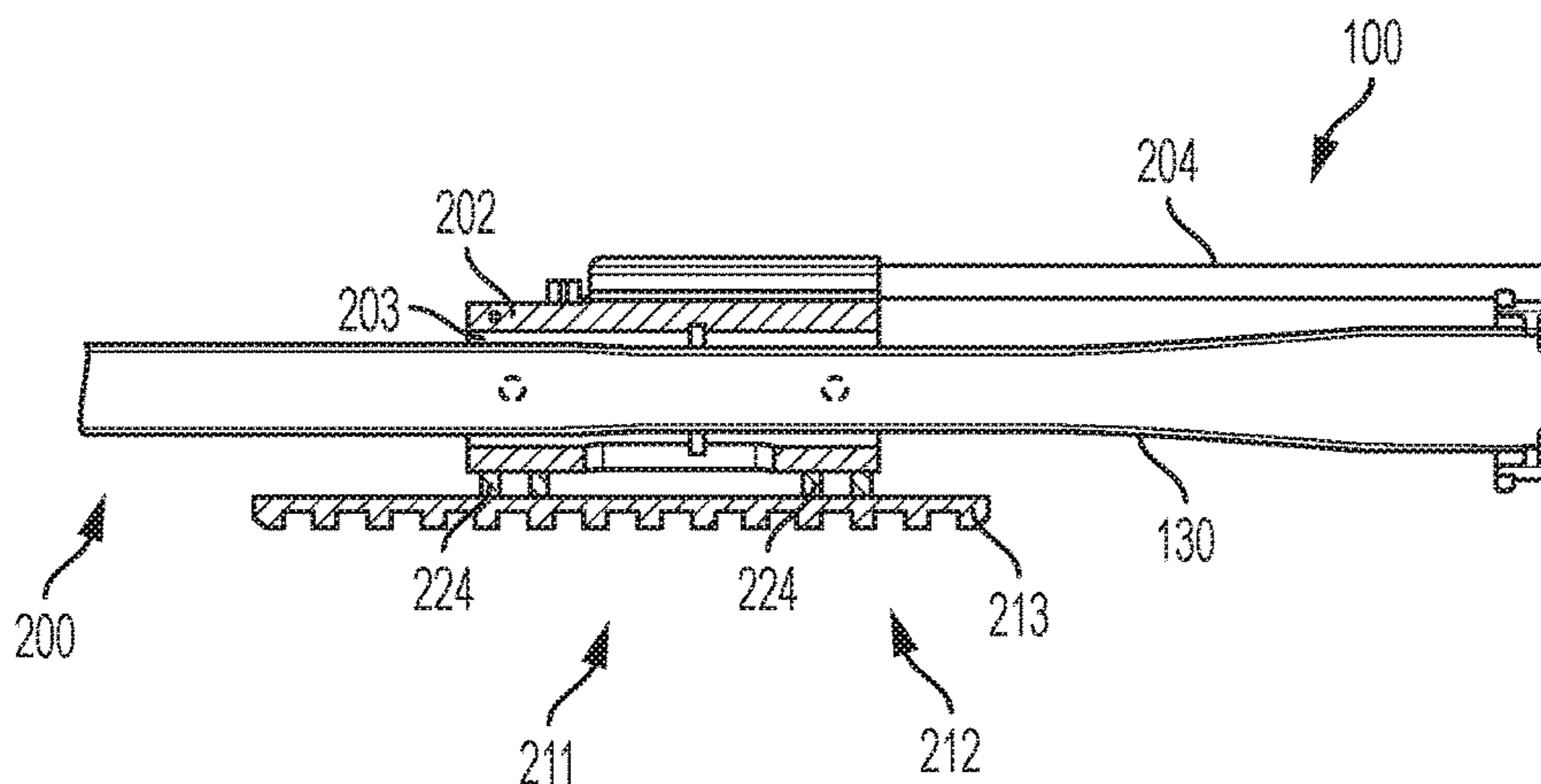

FIG. 3B

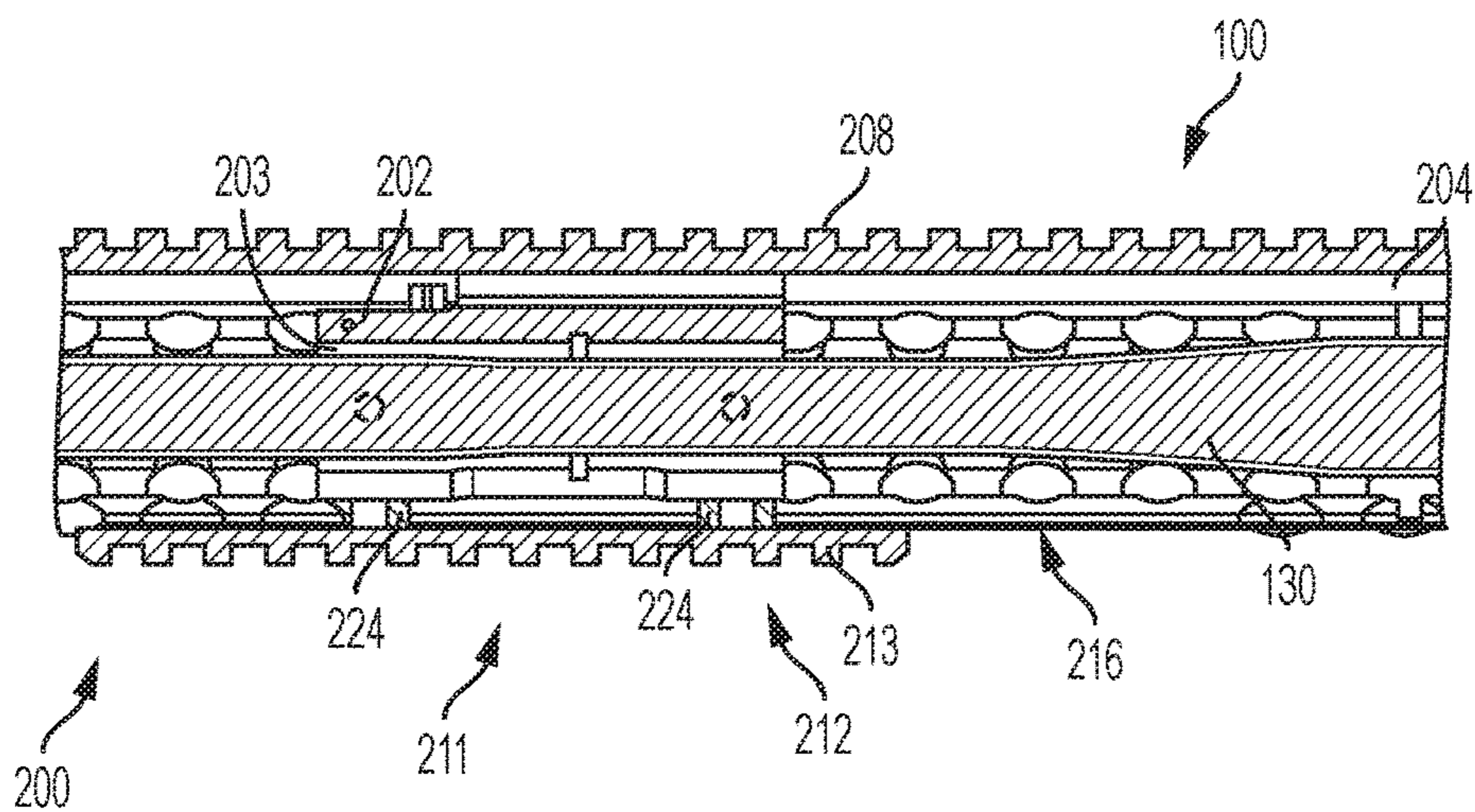

FIG. 3C



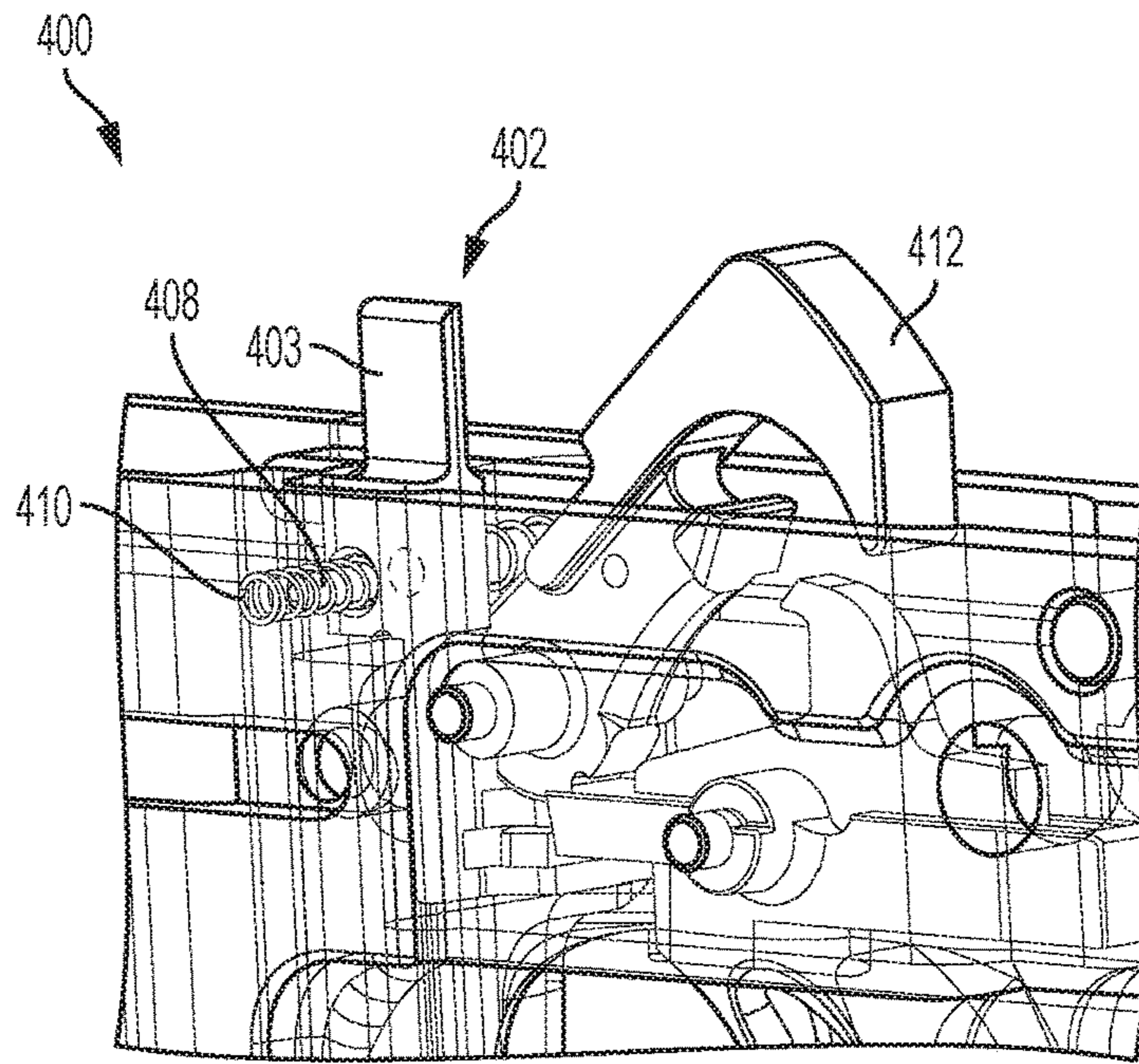

FIG. 4A

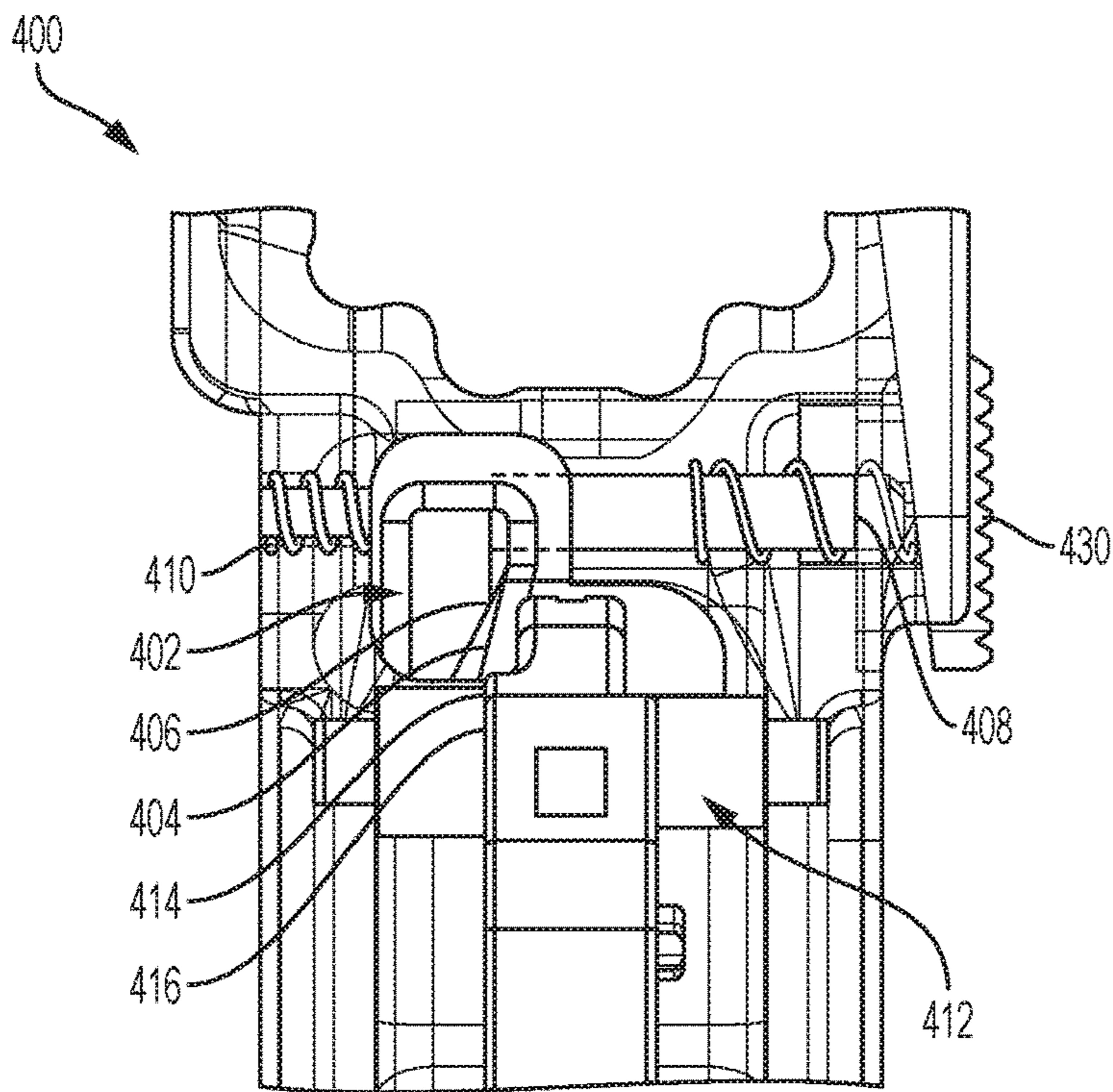

FIG. 4B

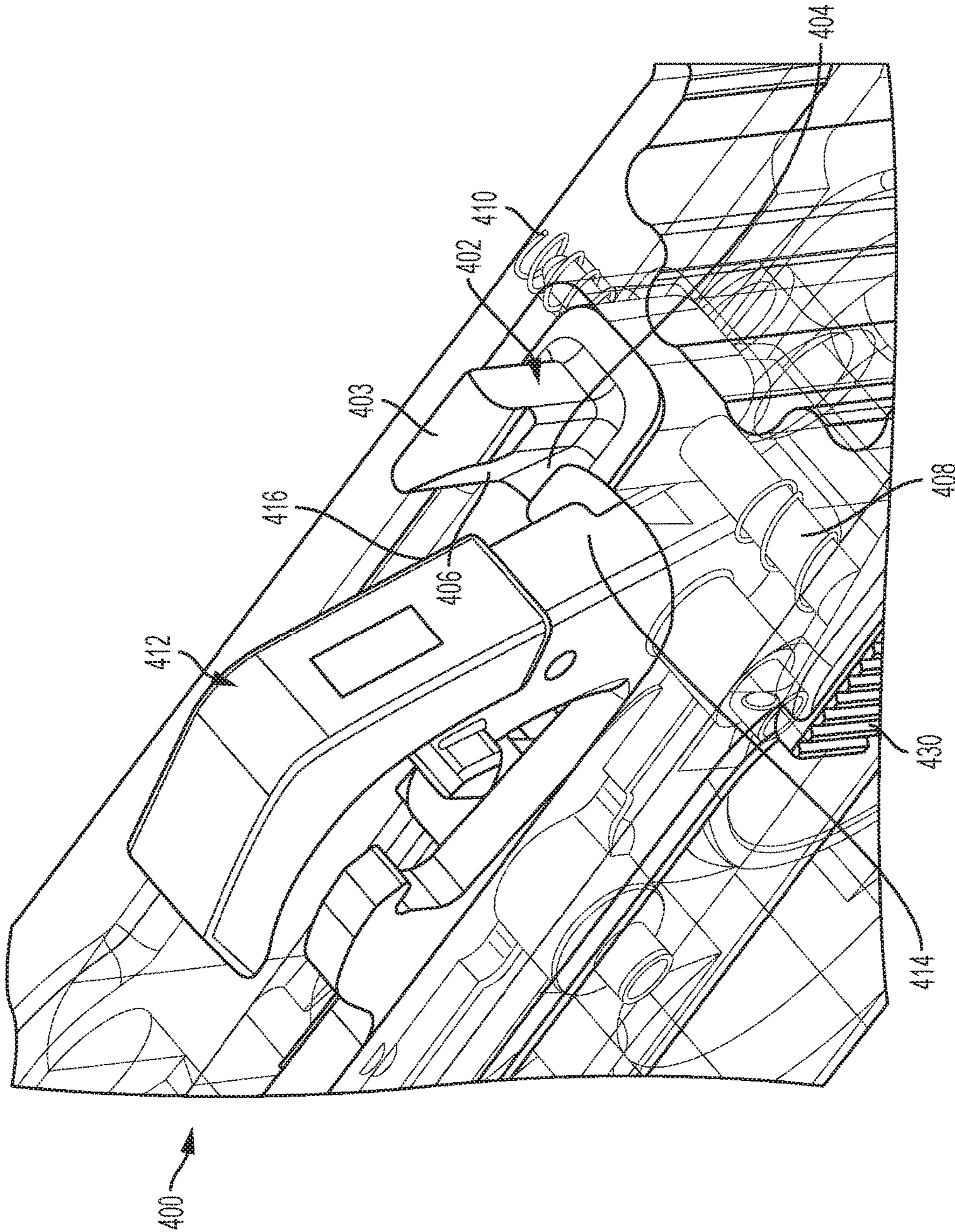
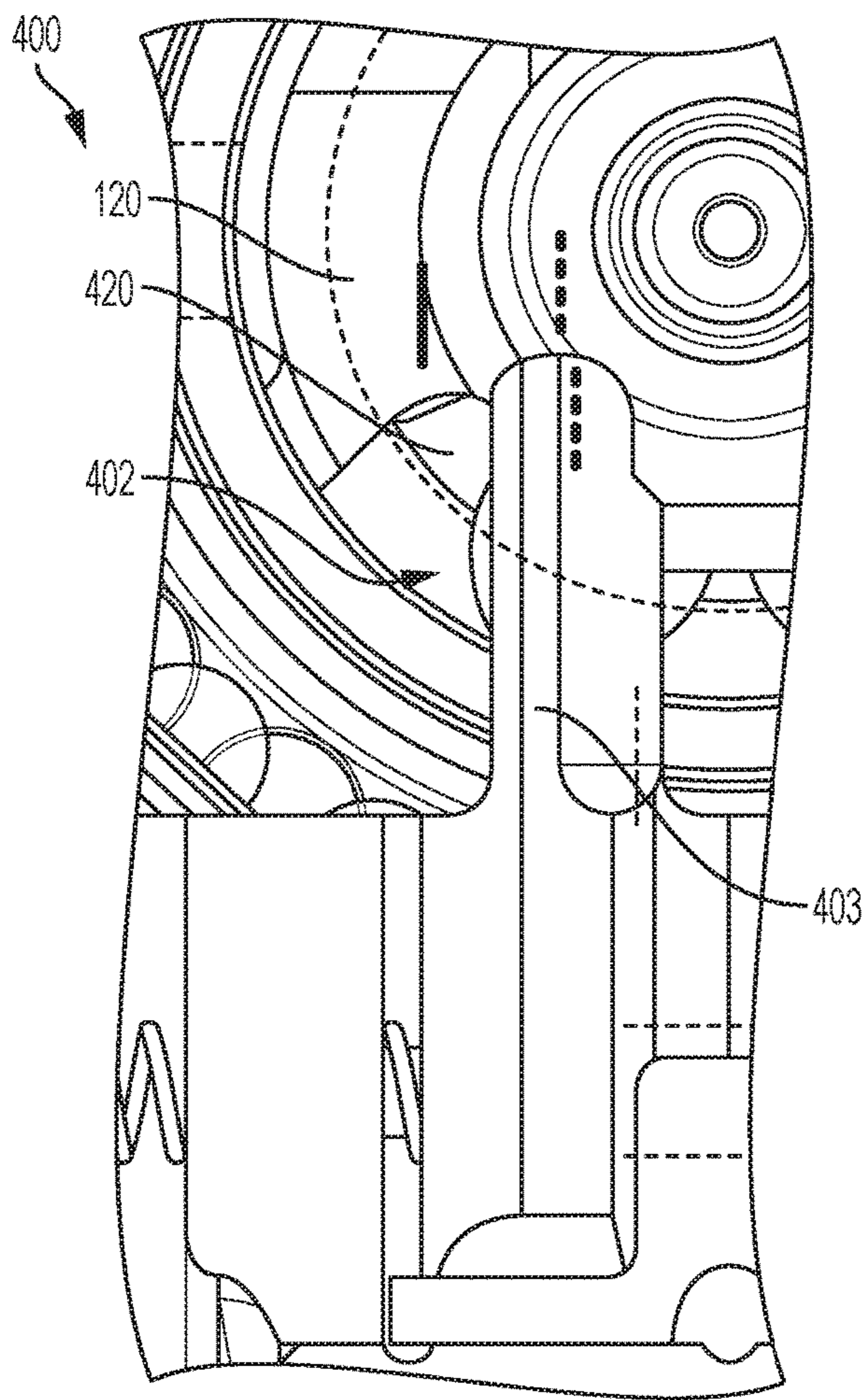
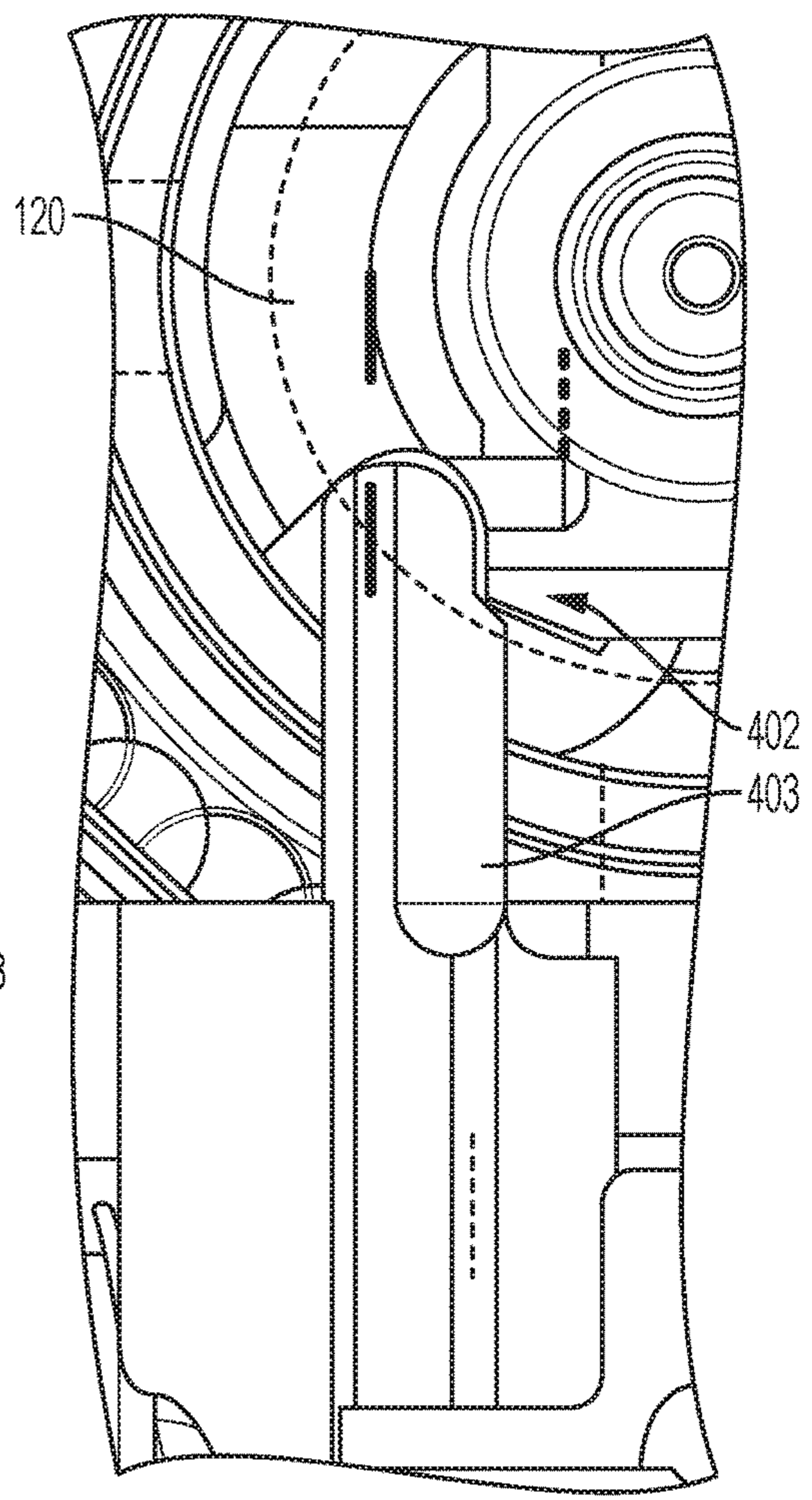

FIG. 4C



----- LOCKED

FIG. 4D



———— UN-LOCKED

FIG. 4E

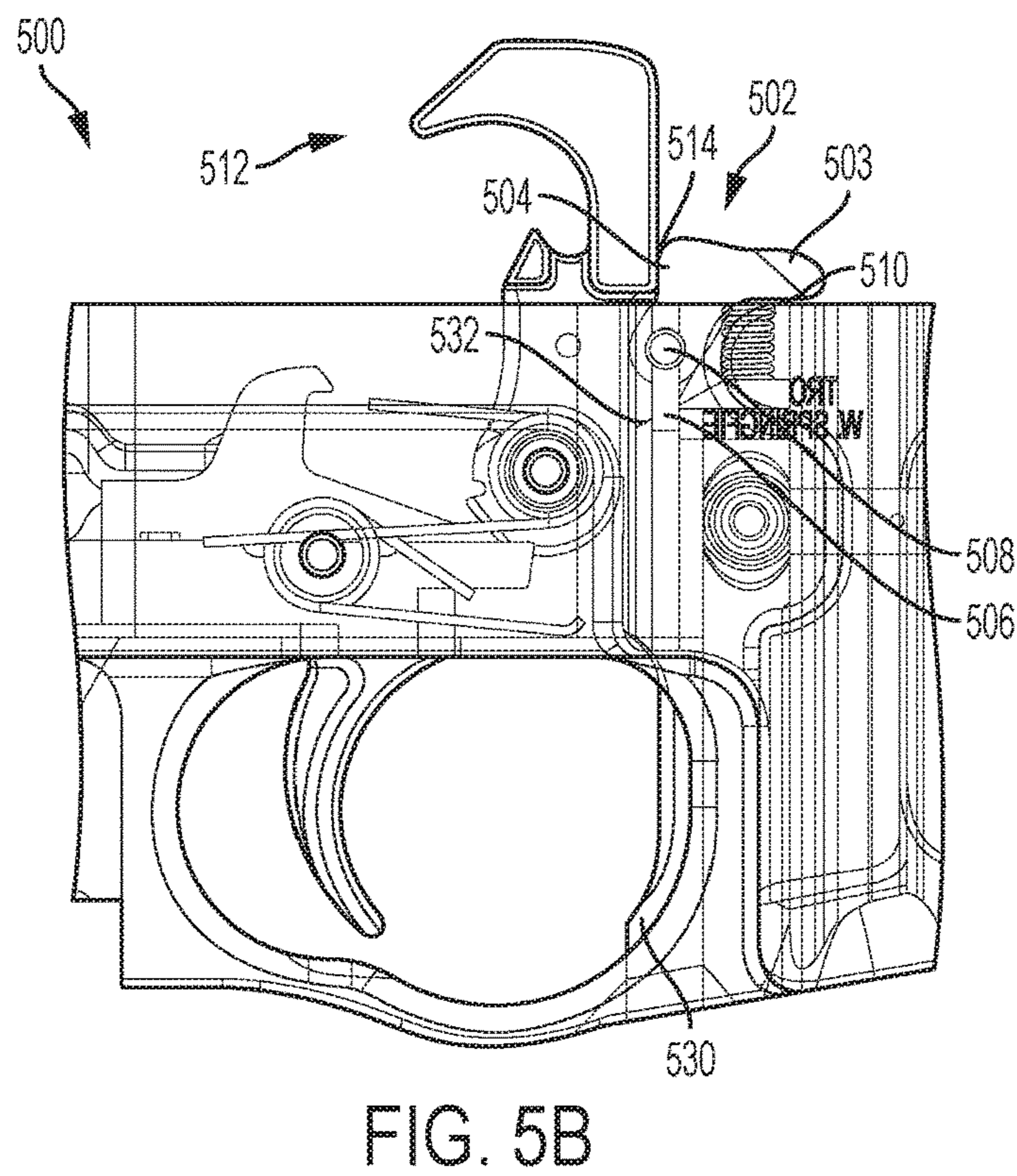
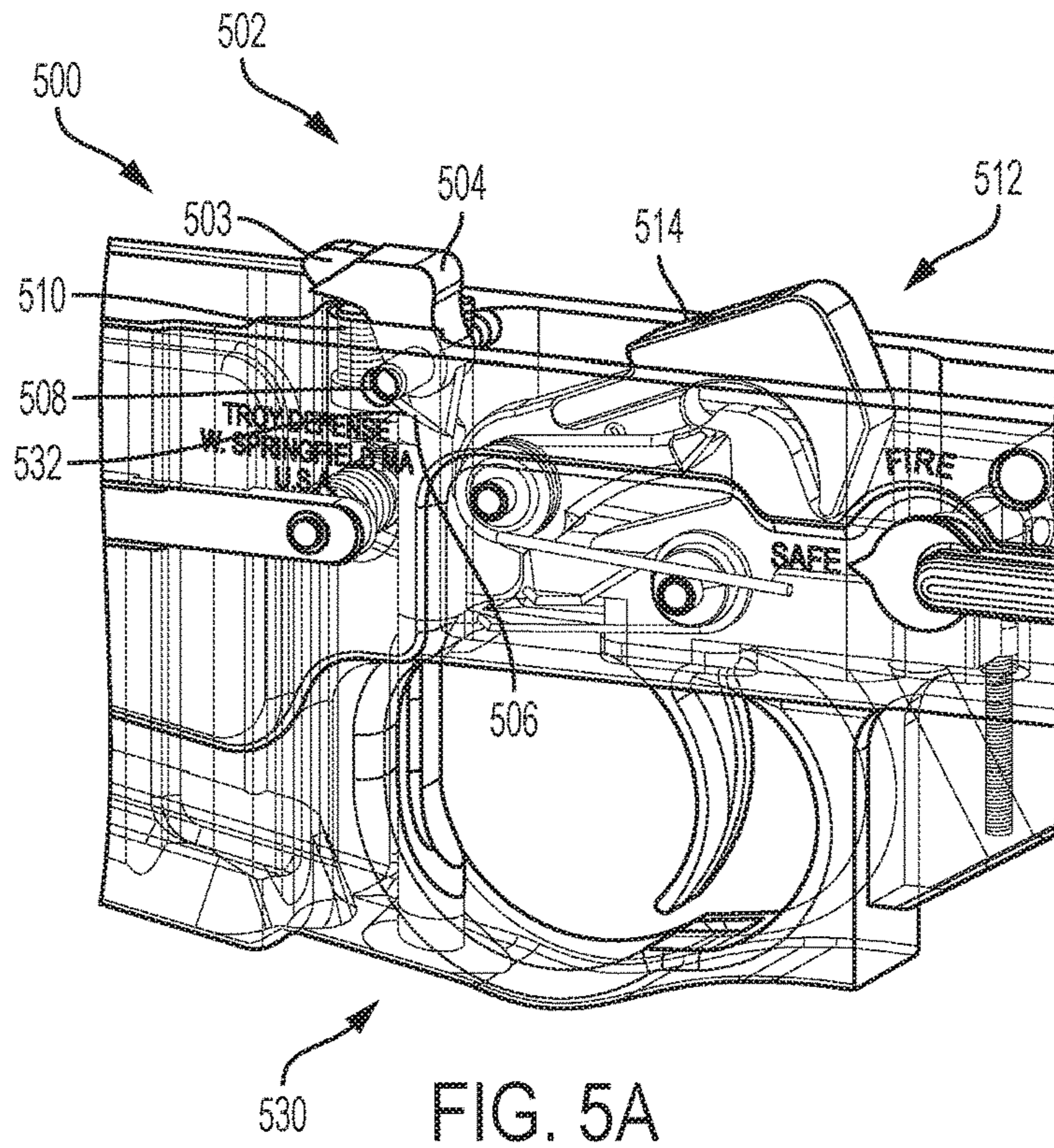

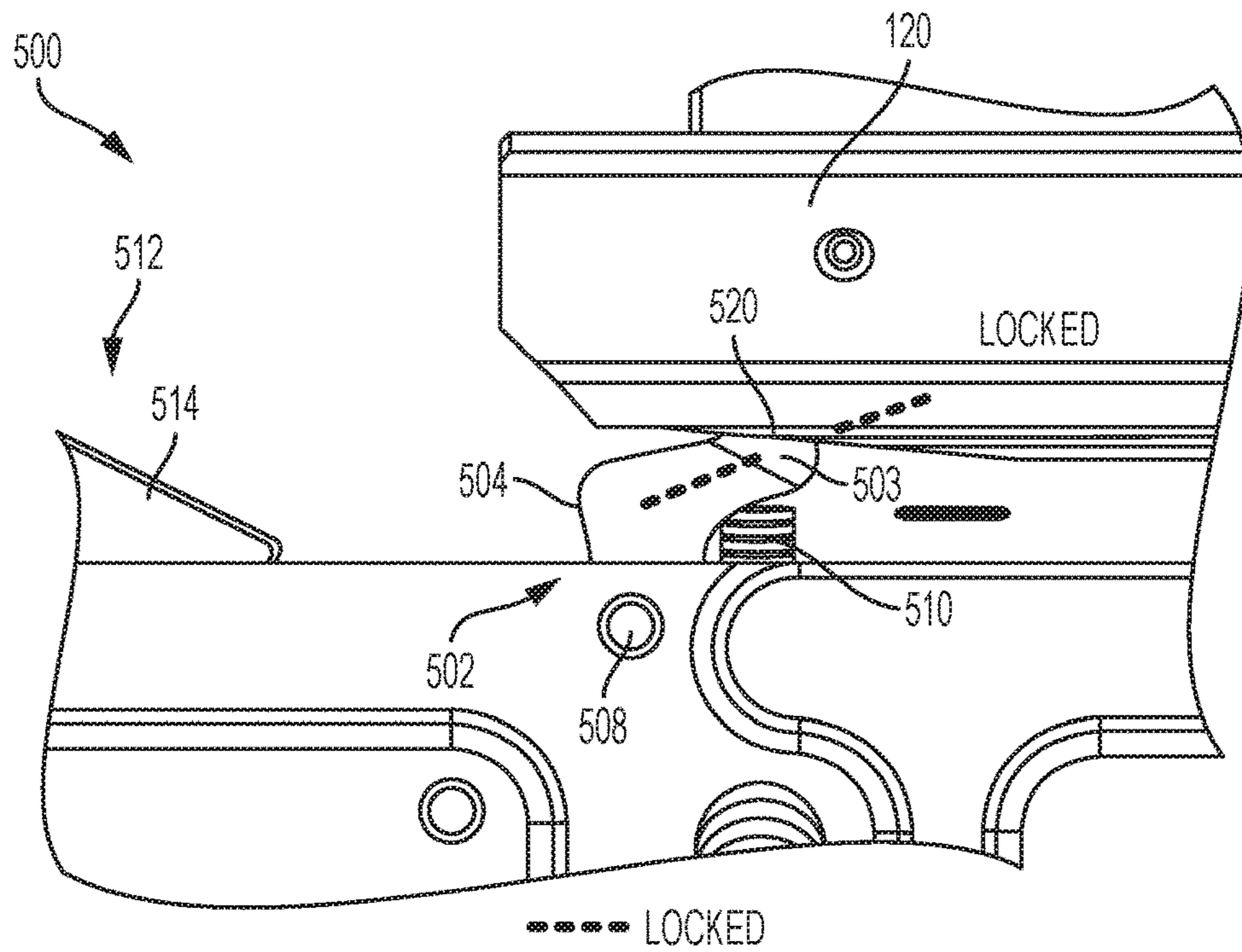

FIG. 5C

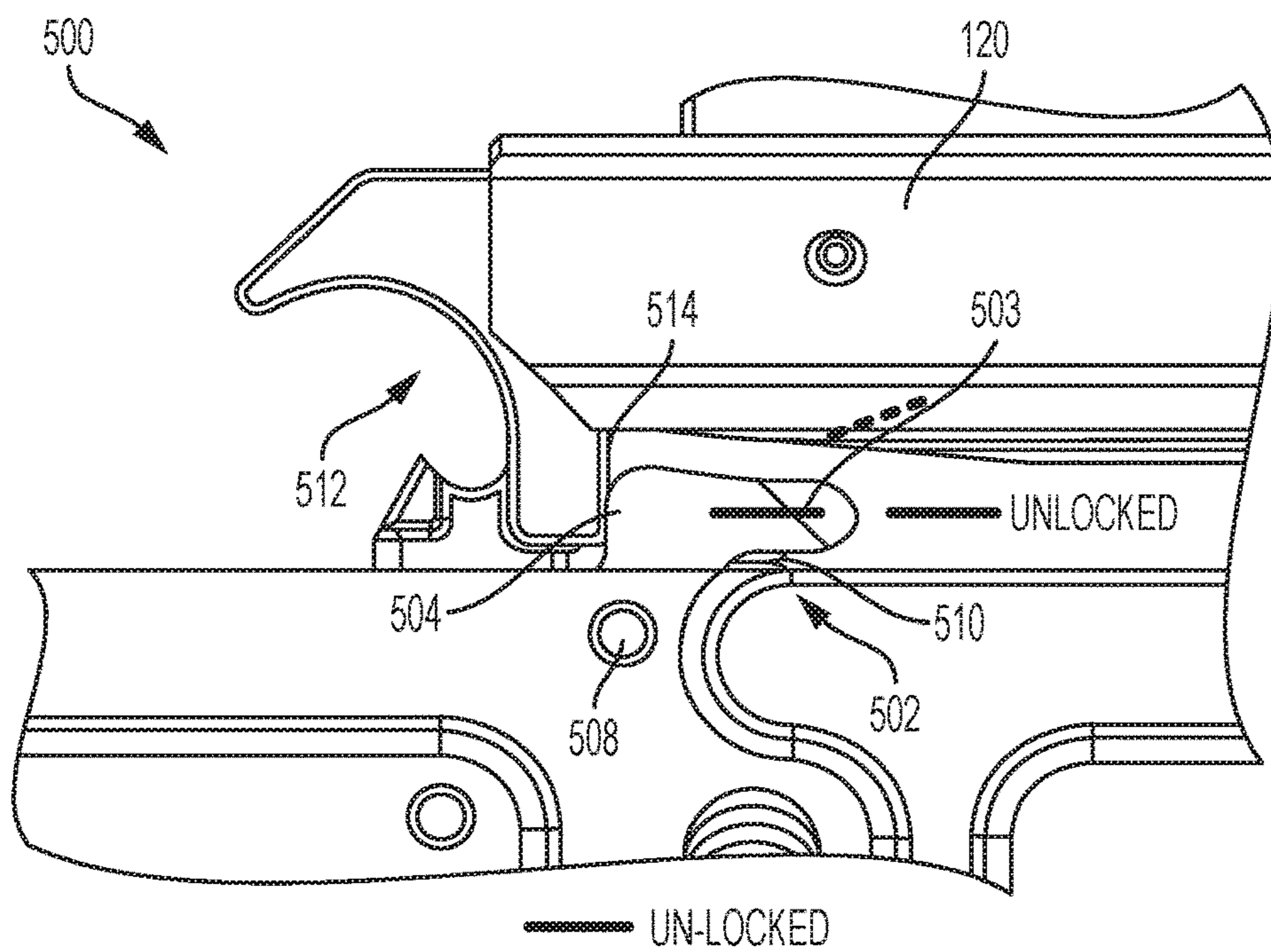

FIG. 5D

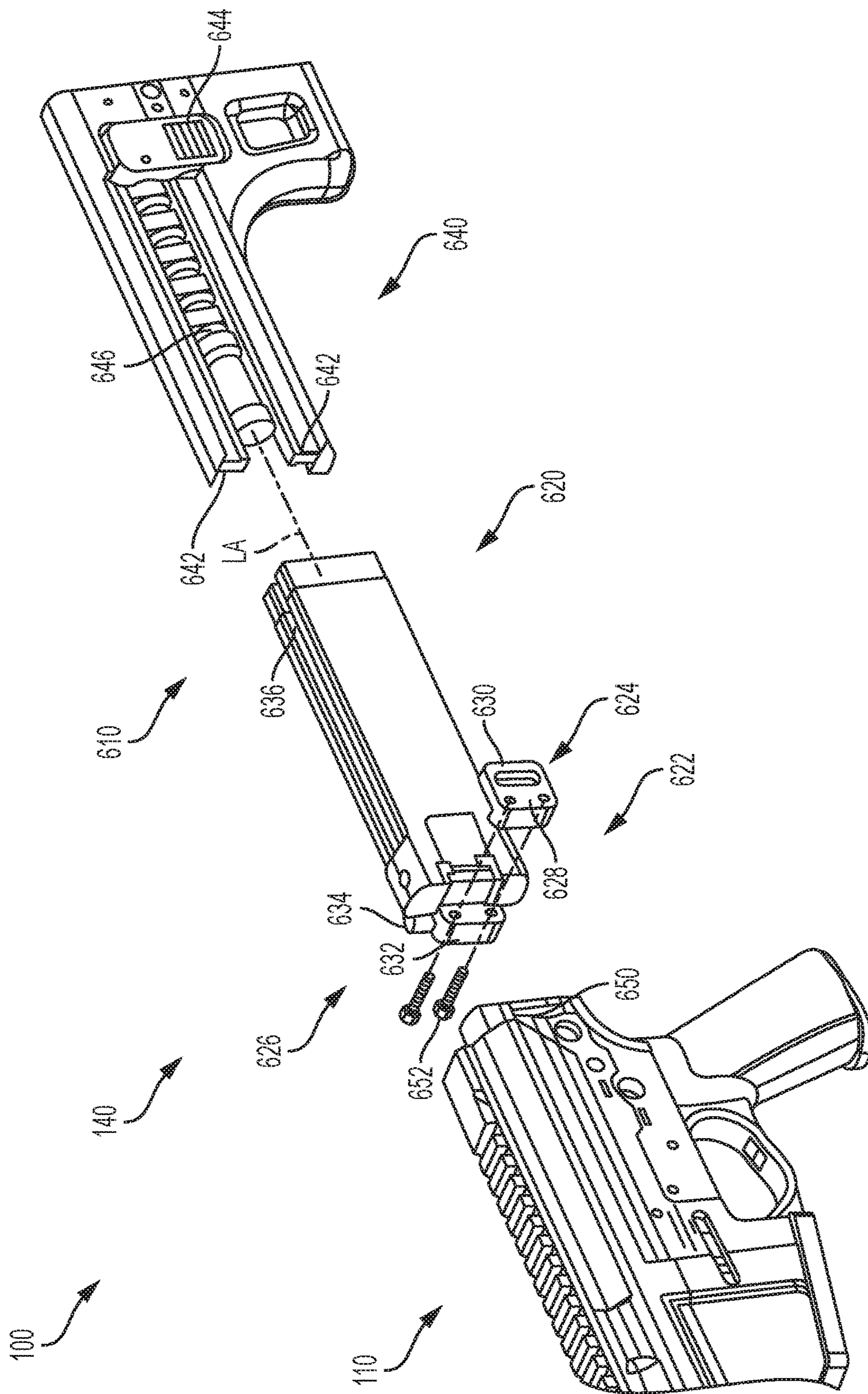

FIG. 6A

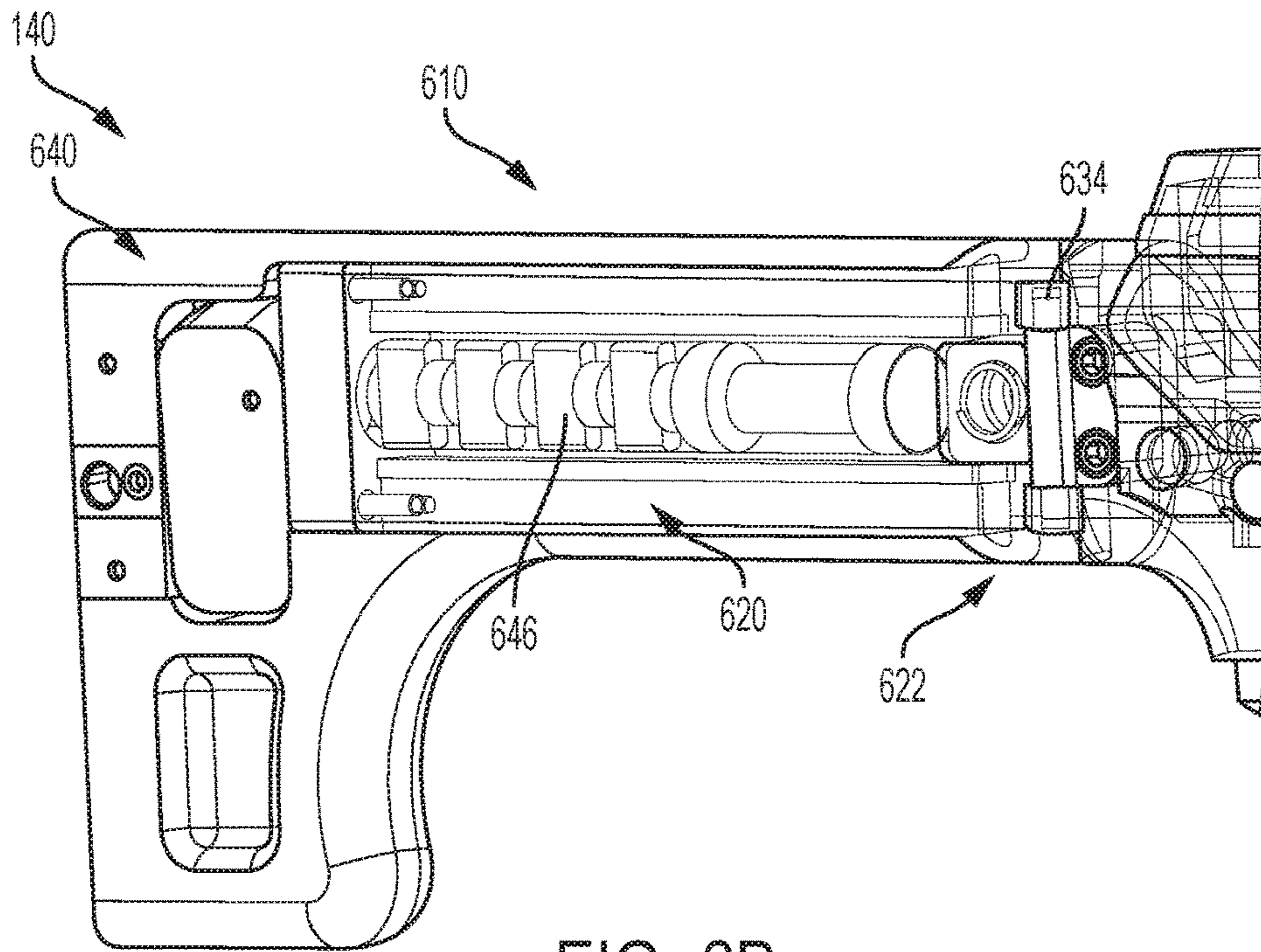

FIG. 6B

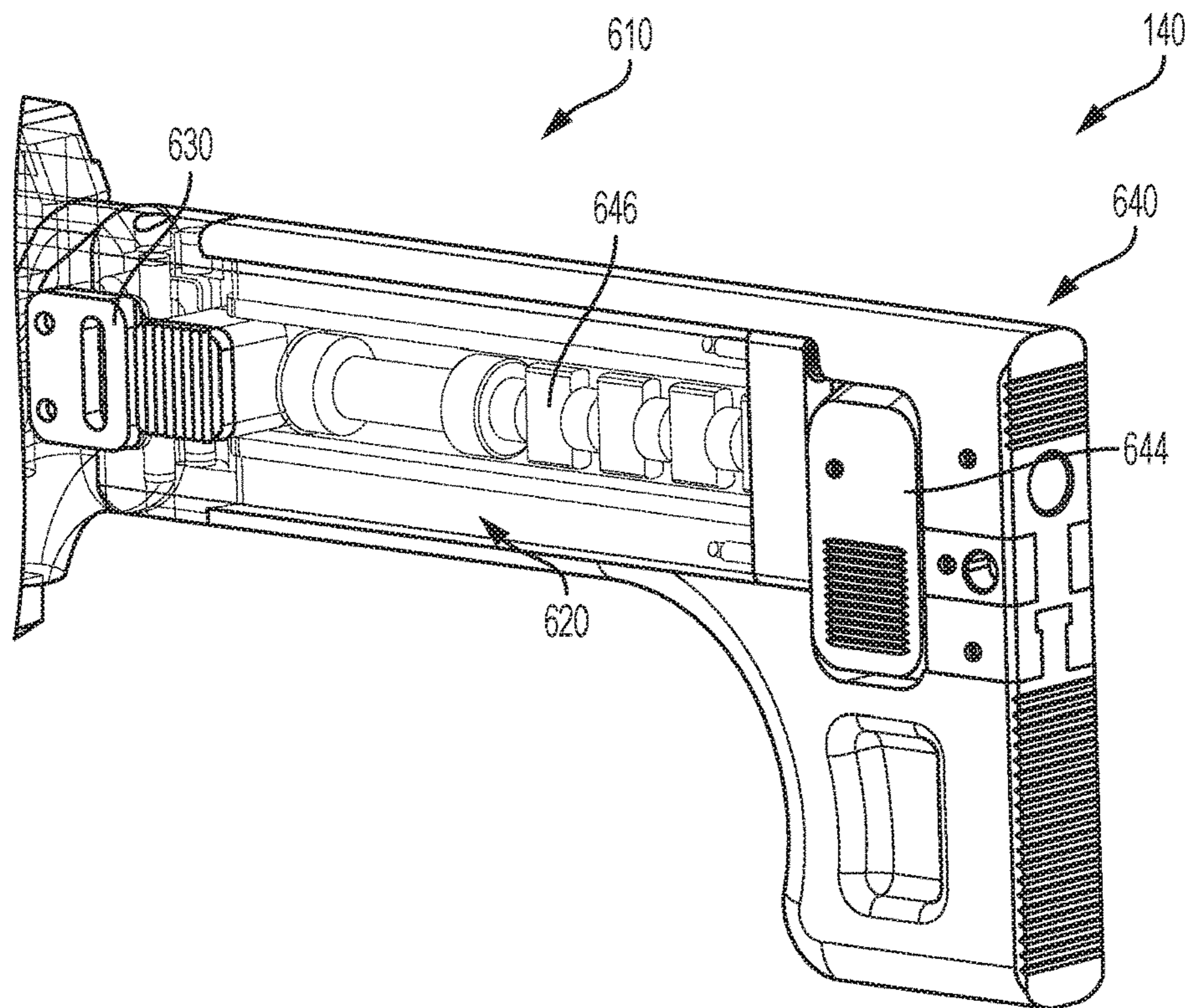

FIG. 6C

1

**PUMP-ACTION FIREARM WITH BOLT  
CARRIER LOCKING MECHANISM AND  
FOLDING BUTT STOCK**

CROSS REFERENCE TO RELATED  
APPLICATIONS

This application is a divisional application of U.S. application Ser. No. 14/284,376 filed May 21, 2014, now pending, which claims the benefit of the filing date of U.S. provisional patent application Ser. No. 61/897,170, filed Oct. 29, 2013, the entire disclosure of each of which is incorporated herein by reference.

FIELD

The present disclosure relates generally to firearms and, more particularly, to pump-action firearms, such as a pump-action rifle, which may include a bolt carrier locking mechanism and a folding butt stock.

BACKGROUND

Certain semi-automatic and automatic firearms, such as the family of AR-15/M16 rifles, operate with a gas operating system in which hot propellant combustion gas from a fired cartridge is made to operate the bolt carrier to cycle the action of the firearm.

The gas operating system of an AR-15/M16 rifle may be a direct gas impingement system, or a gas operated piston system. The direct gas impingement system directs hot propellant combustion gas from a fired cartridge directly to a bolt carrier to cycle the action of the firearm. More particularly, the gas pressure of the combustion gas pushes the bolt carrier rearward against the bias of a buffer spring, during which time the fired cartridge case is extracted from the chamber of the barrel and ejected from the firearm. As the gas pressure dissipates, the compressed buffer spring then decompresses and pushes the bolt carrier forward, during which time an unfired cartridge is removed from the magazine and loaded into the chamber of the barrel. In contrast to a direct gas impingement system, with a gas operated piston system, the gas forces a piston rod of a piston and the bolt carrier rearward to handle the extraction and ejection process, and thereafter the bolt carrier is forced forward by a decompression of the buffer spring to the closed position just as with direct impingement.

Operation of semi-automatic and automatic firearms, including operation of the AR-15/M16 family of rifles, is well known and described, for example, in U.S. Patent Application Publication No. US2012/0137872, the teachings of which are hereby incorporated herein by reference.

Certain shotguns may be operated with either a semi-automatic reload system or a manual pump-action reloading system. With a manual pump-action reloading system, rather than the reloading system being operated by gas from a fired cartridge, actuation of the reloading system is performed manually by the operator (shooter) of the shotgun. For both the semi-automatic and pump-action shotguns, shotgun shells are generally stored in a tubular magazine beneath the barrel, which is not detachable from the shotgun such that the shotgun may be operated with the use of multiple magazines.

SUMMARY

A firearm according to the present disclosure may be understood as a pump-action firearm, particularly a pump-

2

action rifle. More particularly, the pump-action firearm of the present disclosure may be made to look similar to, as well as share many features with, an AR-15/M16 rifle, although the firearm of the present disclosure operates with a pump-action reload mechanism rather than with a traditional gas operated reloading system associated with an AR-15/M16. In addition, or alternatively, a firearm according to the present disclosure may include a bolt carrier locking mechanism and/or a butt stock that may be folded in either direction toward the receiver of the firearm.

In at least one embodiment, a firearm according to the present disclosure may comprise a barrel; a handguard disposed around the barrel; a manually operated pump-action reload mechanism, the pump-action reload mechanism comprising a hand-held actuation arrangement and a fore-end body, the fore-end body disposed around the barrel between the handguard and the barrel; and the hand-held actuation arrangement coupled to the fore-end body to operate the pump-action reload mechanism.

In at least one embodiment, the pump-action reload mechanism may further comprise an operation rod, and the operation rod may be coupled to the fore-end body and a bolt carrier of the firearm.

In certain embodiments, the fore-end body may be arranged to travel along a length of the barrel during an operation of the pump-action reload mechanism without the fore-end body contacting the barrel.

In at least one embodiment, the hand-held actuation arrangement may comprise a first actuation section.

In at least one embodiment, the handguard may comprise a first actuation section travel slot, and the first actuation section may be configured to travel within the first actuation section travel slot during a reloading of the firearm.

In at least one embodiment, the fore-end body may be disposed inside the handguard, the first actuation section may comprise a first hand-grip segment disposed outside the handguard and the fore-end body and the first hand-grip segment may be coupled to one another by at least one fastening device disposed within the first elongated slot.

In at least one embodiment, the first hand-grip segment may be adjacent an outside surface of the handguard.

In at least one embodiment, the at least one fastening device may be located within a stand-off boss on at least one of the first hand-grip segment and the fore-end body.

In at least one embodiment, the stand-off boss may be disposed within the first actuation section travel slot.

In at least one embodiment, the first hand-grip segment may comprise a rail segment.

In at least one embodiment, the rail segment may have a T-shaped profile.

In at least one embodiment, the first actuation section may comprise a plastic hand-grip.

In at least one embodiment, the first actuation section may be disposed beneath the barrel.

In at least one embodiment, the hand-held actuation arrangement may comprise a second actuation section.

In at least one embodiment, the handguard may comprise a second actuation section travel slot, and the second actuation section may be configured to travel within the second actuation section travel slot during the reloading of the firearm.

In at least one embodiment, the second actuation section may be disposed on a side of the barrel approximately 90 degrees from the first actuation section.

In at least one embodiment, the first actuation section and the second actuation section may be discrete components of the hand-held actuation member.



3

In at least one embodiment, the hand-held actuation arrangement may comprise a third actuation section.

In at least one embodiment, the handguard may comprise a third actuation section travel slot, and the third actuation section may be configured to travel within the third actuation section travel slot during the reloading of the firearm.

In at least one embodiment, the third actuation section may be disposed on a side of the barrel approximately 180 degrees from the second actuation section.

In at least one embodiment, the first actuation section, the second actuation section and the third actuation section may be discrete components of the hand-held actuation member.

In at least one embodiment, the firearm may be a rifle.

In at least one embodiment, the firearm may further comprise a bolt and a bolt carrier, and, during operation of the firearm, the bolt may be locked with the barrel.

In at least one embodiment, the firearm may further comprise a detachable magazine.

In at least one embodiment, the firearm may further comprise a bolt carrier, and a bolt carrier locking mechanism arranged to inhibit the bolt carrier from rearward travel while an unfired cartridge is located in a chamber of the barrel.

In at least one embodiment, the bolt carrier locking mechanism may comprise a bolt carrier locking member, and the bolt carrier locking member may be movable transverse to a longitudinal axis of the bolt carrier.

In at least one embodiment, the firearm may further comprise a firing hammer; and the firing hammer and the bolt carrier locking member may be arranged such that the bolt carrier locking member is arranged to move transverse to the longitudinal axis of the bolt carrier and out of alignment with the firing hammer in response to being contacted by the firing hammer.

In at least one embodiment, the bolt carrier locking mechanism may comprise a spring, and the bolt carrier locking member and the spring may be arranged such that a transverse movement of the bolt carrier locking member in response to being contacted by the firing hammer is biased by the spring.

In at least one embodiment, the bolt carrier locking member may be arranged to move transverse to the longitudinal axis of the bolt carrier on a pin.

In at least one embodiment, the bolt carrier locking mechanism may comprise a manual release button, and the manual release button and the bolt carrier locking member may be arranged such that pushing on the manual release button moves the bolt carrier locking member transverse to the longitudinal axis of the bolt carrier.

In at least one embodiment, the bolt carrier locking mechanism may comprise a bolt carrier locking member, and the bolt carrier locking member may be rotatable on an axis which is transverse to a longitudinal axis of the bolt carrier.

In at least one embodiment, the firearm may further comprise a firing hammer, and the firing hammer and the bolt carrier locking member may be arranged such that the bolt carrier locking member is arranged to rotate out of engagement with the bolt carrier in response to being contacted by the firing hammer.

In at least one embodiment, the bolt carrier locking mechanism may comprise a spring, and the bolt carrier locking member and the spring may be arranged such that a rotational movement of the bolt carrier locking member in response to being contacted by the firing hammer is biased by a spring.

4

In at least one embodiment, the bolt carrier locking member may be arranged to rotate out of engagement with the bolt carrier on a pin.

In at least one embodiment, the bolt carrier locking mechanism may comprise a manual release button, and the manual release button and the bolt carrier locking member may be arranged such that pushing the manual release button rotates the bolt carrier locking member out of engagement with the bolt carrier.

In at least one embodiment, a butt stock for a firearm according to the present disclosure may comprise the butt stock arrangeable in a first configuration to fold toward a first side of a receiver of the firearm into a first folded position along the first side of the receiver, and unfoldable away from the first side of the receiver of the firearm into an unfolded position rearward of the receiver, and the butt stock arrangeable in a second configuration to fold toward a second side of the receiver of the firearm into a second folded position along the second side of the receiver, and unfoldable away from the second side of the receiver of the firearm into the unfolded position rearward of the receiver.

In at least one embodiment, the butt stock may further comprise a hinge, and, in the first configuration of the butt stock, the hinge may be disposed to the first side of the receiver, and, in the second configuration of the butt stock, the hinge may be disposed to the second side of the receiver.

In at least one embodiment, the butt stock may be connectable to the receiver by a mounting bracket member which includes the hinge.

In at least one embodiment, the butt stock of claim may further comprise a latch, and, in the first configuration of the butt stock, the latch may be disposed to the second side of the receiver, and, in the second configuration of the butt stock, the latch may be disposed to the first side of the receiver.

In at least one embodiment, the butt stock may be connectable to the receiver by a mounting bracket member which includes the latch.

In at least one embodiment, the butt stock of claim may further comprise an extendable elongated body comprising a first elongated body member and a second elongated body member, the butt stock has a longitudinal axis, and to arrange the butt stock in the second configuration from the first configuration, the first body member may be rotated about the longitudinal axis of the butt stock relative to the second elongated body member.

In at least one embodiment, the second body member slides relative to the first body member to adjust a length of the butt stock.

In at least one embodiment, the length of the butt stock may be locked by a locking mechanism.

#### BRIEF DESCRIPTION OF THE DRAWINGS

Features and advantages of the claimed subject matter will be apparent from the following detailed description of embodiments consistent therewith, which description should be considered with reference to the accompanying drawings, wherein:

FIG. 1 is a perspective view of a firearm having a manually operated pump-action reload mechanism according to the present disclosure;

FIG. 2A is a cross-sectional perspective view of a fore-end portion of the pump-action reload mechanism of the firearm of FIG. 1 according to a first embodiment of the present disclosure;

## 5

FIG. 2B is a close-up perspective view of portion of a fore-end body and an operation rod of the pump-action reload mechanism of the first embodiment;

FIG. 2C is a cross-sectional side view of the fore-end portion of the pump-action reload mechanism of the first embodiment, with the handguard removed;

FIG. 2D is a cross-sectional side view of the fore-end portion of the pump-action reload mechanism of the first embodiment, with the handguard present;

FIG. 2E is a perspective view of the pump-action reload mechanism of the first embodiment;

FIG. 2F is a cross-sectional view of the fore-end portion of the pump-action reload mechanism of the first embodiment, taken along section line 2F-2F of FIG. 2A;

FIG. 3A is a cross-sectional perspective view of a fore-end portion of the pump-action reload mechanism of the firearm of FIG. 1 according to a second embodiment of the present disclosure;

FIG. 3B is a cross-sectional side view of the fore-end portion of the pump-action reload mechanism of the second embodiment, with the handguard removed;

FIG. 3C is a cross-sectional side view of the fore-end portion of the pump-action reload mechanism of the second embodiment, with the handguard present;

FIG. 4A is a side perspective view of a bolt carrier locking mechanism according to a first embodiment of the present disclosure;

FIG. 4B is a top view of a bolt carrier locking mechanism of the first embodiment;

FIG. 4C is a top perspective view of a bolt carrier locking mechanism of the first embodiment;

FIG. 4D is a cross-sectional view taken transverse to the longitudinal axis of the bolt carrier showing the bolt carrier locking mechanism of the first embodiment in a locked position;

FIG. 4E is a cross-sectional view taken transverse to the longitudinal axis of the bolt carrier showing the bolt carrier locking mechanism of the first embodiment in an unlocked position;

FIG. 5A is a side perspective view of a bolt carrier locking mechanism according to a second embodiment of the present disclosure;

FIG. 5B is a side view of a bolt carrier locking mechanism of the second embodiment;

FIG. 5C is a side view of a bolt carrier locking mechanism of the second embodiment showing the bolt carrier locking mechanism in a locked position;

FIG. 5D is a side view of a bolt carrier locking mechanism of the second embodiment showing the bolt carrier locking mechanism in an unlocked position;

FIG. 6A is an exploded perspective view of a butt stock according to the present disclosure;

FIG. 6B is a right side assembled perspective view of the butt stock of FIG. 6A; and

FIG. 6C is a left side assembled perspective view of the butt stock of FIG. 6A.

## DETAILED DESCRIPTION

A firearm according to the present disclosure may be understood as a pump-action firearm, particularly a pump-action rifle. More particularly, the pump-action firearm of the present disclosure may be made to look similar to, as well as share many features with, an AR-15/M16 rifle, although the firearm of the present disclosure operates with a pump-action reload mechanism, rather than with a traditional gas operated reloading system associated with an

## 6

AR-15/M16. In addition, or alternatively, a firearm according to the present disclosure may include a bolt carrier locking mechanism and/or a butt stock that may be folded in either direction toward the receiver of the firearm.

As may be understood, a pump-action firearm includes a fore-end which may be “pumped” rearward relative to the firearm (and the firing direction thereof) to eject a fired cartridge casing from the chamber of the barrel of the firearm, and thereafter “pumped” forward relative to the firearm (and the firing direction thereof) to extract an unfired cartridge from a magazine and load the unfired cartridge into the chamber of the barrel.

Turning now to FIG. 1, there is illustrated a firearm 100 according to the present disclosure. Firearm 100 includes a receiver 110 comprising a lower receiver 112 and mating upper receiver 114. Upper receiver 114 includes bolt carrier 120 including a firing pin, as well as a cartridge loading and unloading mechanism. A barrel 130 is affixed to the front end of upper receiver 114 and a butt stock 140 is affixed to the rear end of lower receiver 112. A trigger portion of upper receiver 114 fits into an access opening in lower receiver 112 and is integrated with the internal mechanism of upper receiver 114 and lower receiver 112. A pistol grip 116 is attached to lower receiver 112. A detachable (removable) box magazine as known in the art (shown in phantom) may be inserted into a magazine receptacle 118 having a downwardly oriented access opening in lower receiver 112 for feeding cartridges to the cartridge insertion and ejection mechanism within upper receiver 114. The detachable magazine is capable of being loaded and unloaded while detached from firearm 100, and holds the cartridges side-by-side in one or more columns/rows, which may be staggered. In certain embodiments, the detachable magazine may also comprise a drum magazine in which the cartridges are positioned and fed in an unwinding spiral.

A handguard 150 is affixed to the front end of upper receiver 114 and surrounds and protects a portion of barrel 130. A pump-action reload mechanism 200 overlies at least a proximal portion of the barrel 130 and the handguard 150.

During operation of the pump-action reload mechanism 200, as the mechanism is “pumped” rearward relative to the firearm (and the firing direction thereof), a rearward force is applied to the bolt carrier 120 which forces the bolt carrier 120 to travel rearwards and the bolt to rotate in the bolt carrier 120 via a cam and pin setup. As with the AR-15/M16, the rotation of the bolt disengages radial locking teeth, located at the bolt head, from the lugs on the barrel extension, unlocking the bolt and allowing the bolt carrier to fully travel rearward, thereby extracting and ejecting a fired cartridge case on its rearward motion.

Thereafter, as the pump-action reload mechanism 200 is “pumped” forward relative to the firearm (and the firing direction thereof), the bolt carrier 120 travels forward, during which time an unfired cartridge is removed from the magazine and loaded into the chamber of the barrel 130. Once the bolt comes into the battery (forward most position), the bolt carrier 120 forces it to rotate and lock with the barrel extension.

A first embodiment of a manually operated pump-action reload mechanism 200 of firearm 100 according to the present disclosure is illustrated in FIGS. 2A-2F.

In the illustrated exemplary embodiment, the pump-action reload mechanism 200 of the operating system of the firearm 100 includes a fore-end (pump) body 202 that is coupled by operation rod 204 to bolt carrier 120 of firearm 100 (as shown in FIG. 2E). Those of ordinary skill in the art will recognize that the forward end of the operation rod 204 may

be coupled, directly or indirectly, to the fore-end body **202** and the opposing rearward end of the operation rod **204** may be coupled, directly or indirectly, to the bolt carrier **120** by a variety of means depending on the configuration of the firearm **100**. For example, the operation rod **204** may be secured to the fore-end body **202** and the bolt carrier **120** by one or more mechanical fastening devices, by welding, etc.

In addition, although the illustrated exemplary embodiment illustrates only a single operation rod **204** which extends along the top of the barrel **130**, more than one operation rod **204** may be used to couple the fore-end body **202** to the bolt carrier **120**. Those of ordinary skill in the art will recognize that the fore-end of the firearm **100** may be understood to be that portion of the firearm **100** forward of the trigger guard or receiver **110**.

The fore-end body **202** is disposed around the barrel **130**, particularly between the barrel **130** and an outer tubular (cylindrical) handguard **208** (which is shown to comprise a railed handguard having a Picatinny rail along the top thereof) which is disposed around and surrounds the fore-end body **202** and the barrel **130**. The tubular structure of the handguard **208** may be provided by a single piece tubular member or may be provided by two or more semi-circular members fastened together.

In the illustrated exemplary embodiment, the fore-end body **202** has a substantially cylindrical tubular shape, with the barrel **130** extending through a centrally located cylindrical through passage **203** of the fore-end body **202**. As best shown by FIG. 2F, the diameter of the cylindrical through passage **203** is greater than the outside diameter of the barrel **130** such that the fore-end body **202** may travel along a length of the barrel **130** with reciprocating movement along the inside profile **206** of the handguard **208** during an operation of the pump-action reload mechanism **200** without the fore-end body **202** making contact with the barrel **130**, allowing the barrel **130** to free-float increasing the rifle's accuracy. As shown, the inside profile **206** of the handguard **208** includes a plurality of parallel, semi-circular ribs **207** which extend longitudinally with the handguard **208** and which surround the fore-end body **202** to better enable operation of the fore-end body **202**.

The fore-end body **202** is also coupled to a hand-held actuation arrangement **211** comprising at least a first actuation section **212** to operate the pump-action reload mechanism **200**. As shown in FIGS. 2A-2F, the first actuation section **212** is disposed beneath the barrel **130**. Also as shown, the handguard **208** comprises a first actuation section travel slot **216**, with the first actuation section **212** being configured to travel within the first actuation section travel slot **216** during a reloading of the firearm **100**.

More particularly, the first actuation section **212** comprises a first actuation section hand-grip segment **213** positioned outside (radially outwardly adjacent the outer surface) of the handguard **208**, which is coupled to the fore-end body **202** by one or more mechanical fastening devices **214** (e.g. threaded fasteners) which is disposed within and extends through the first actuation section travel slot **216** in the handguard **208**. As best shown by FIG. 2F, the hand-grip segment **213** may comprise a mounting rail segment having a T-shaped cross-sectional profile (transverse to the longitudinal axis of the barrel **130**). In this manner, the hand-grip segment **213** may also be used to mount accessory components, such as a flashlight, pistol grip or other accessory. In addition, the first actuation section **212** may further comprise a plastic (e.g. rubber) member which overlies the hand-grip segment **213** to make the hand-grip segment **213** easier to hold.

As best shown by FIG. 2F, in order to assemble the first actuation section **212** to the fore-end body **202** after the fore-end body **202** is within the handguard **208**, attachment through-holes **218**, **220** in the first hand-grip segment **213** and the fore-end body **202**, respectively, may be aligned and a fastening device **214** in the form of a threaded fastener (e.g. cap screws) may be inserted therein and threadably engage with female threads within through-hole **220** of fore-end body **202**. As shown, the fastener through-hole **218** formed within the first hand-grip segment **213** may extend through a cylindrical stand-off (mounting) boss **222** which secures against the fore-end body **202**. The mounting boss **222** may be surrounded by a cylindrical bushing **224** which functions as a bearing in the event the bushing **224** makes contact with the inner surface the first actuation section travel slot **216** during actuation of the pump-action reload mechanism **200**.

To chamber a cartridge, the pump-action reload mechanism **200** may be actuated by the operator of firearm **100** grasping the hand-grip segment **213** of the first actuation section **212** of the hand-held actuation arrangement **211** of the pump-action reload mechanism **200** and moving the hand-grip segment **213**/fore-end body **202** rearwards towards the receiver of the firearm **100** by application of a rearward force on the hand-grip segment **213** (which is guided in the first actuation section travel slot **216** with the fastening device **214**/stand-off bosses **222**/bushings **224** traveling within first actuation section travel slot **216**) to unlock the bolt from the barrel **130**, move the bolt carrier **120** and bolt rearward to extract the fired cartridge case from the chamber of the barrel **130**, and ejected the fired cartridge from the firearm **100**.

Thereafter, the pump-action reload mechanism **200** may be actuated by the operator of firearm **100** grasping the hand-grip segment **213** of the first actuation section **212** of the hand-held actuation arrangement **211** of the pump-action reload mechanism **200** and moving the hand-grip segment **213**/fore-end body **202** forward away from the receiver of the firearm **100** by application of a forward force on the hand-grip segment **213** to remove an unfired cartridge from the magazine, load it into the chamber as the bolt and bolt carrier **120** move forward and lock the bolt to the barrel **130**.

As best shown in FIGS. 2E and 2F, the pump-action reload mechanism **200** may further comprise a second hand-grip segment **233** of a second actuation section **232** of the hand-held actuation arrangement **211** which is configured to travel within a second actuation section travel slot **236** during a reloading of the firearm **100**. As shown, the second actuation section **232** of the hand-held actuation arrangement **211** may be disposed on a side of the barrel **130** approximately 90 degrees (within plus (+) or minus (-) 10 degrees) from the first actuation section **212**.

More particularly, the pump-action reload mechanism **200** may further comprise a second actuation section **232** of the hand-held actuation arrangement **211** which is disposed on a left side of the barrel **130** relative to a operator of firearm **100**. As shown FIGS. 2E-2F, the first actuation section **212** and the second actuation section **232** are shown to be discrete components of the hand-held actuation arrangement **211** which directly connect to the fore-end body **202**, and preferably do not connect directly connect to one another.

Furthermore, the pump-action reload mechanism **200** may further comprise a third hand-grip segment **243** of a third actuation section **242** of the hand-held actuation arrangement **211** which is configured to travel within a third actuation section travel slot **246** during a reloading of the firearm **100**. As shown, the third actuation section **242** of the

hand-held actuation arrangement **211** may be disposed on a side of the barrel **130** approximately 180 degrees (within plus (+) or minus (-) 10 degrees) from the second actuation section **232**.

More particularly, the pump-action reload mechanism **200** may further comprise a third actuation section **232** of the hand-held actuation arrangement **211** which is disposed on a right side of the barrel **130** relative to a operator of firearm **100**. As shown FIGS. 2E-2F, the first actuation section **212**, the second actuation section **232** and the third actuation section **242** are each discrete components of the hand-held actuation arrangement **211** which directly connect to the fore-end body **202**, and preferably do not connect directly to one another.

As set forth herein, the forward end of the operation rod **204** may be coupled, directly or indirectly, to the fore-end body **202** by a variety of means depending on the configuration of the firearm **100**. As best shown by FIGS. 2A-2D, the operation rod **204** is shown to extend within a passage **250** within the fore-end body **202**, with the passage **250** extending parallel with passage **203** of the fore-end body **202**.

As best shown by FIG. 2B, a flat-spotted (planar) distal portion **252** of the operation rod **204** is keyed to fit within a planar distal portion **254** of the passage **250** to inhibit the operation rod **204** from rotating relative to the fore-end body **202**. In addition, the operation rod **204** includes a recess **256** which is occupied to a retaining member/locking ring **258** which mechanically interlocks the operation rod **204** within passage **250**.

A second embodiment of a manually operated pump-action reload mechanism **200** of a firearm **100** according to the present disclosure is illustrated in FIGS. 3A-3C. In contrast to the embodiment of FIGS. 2A-2F, with the embodiment of FIGS. 3A-3C, the operation rod **204** may be connected to the fore-end body **202** by being welded or threaded thereto, thus simplifying the attachment of the operation rod **204** to the fore-end body **202**. Also in contrast to the prior embodiment, the pump-action reload mechanism **200** may only comprise a first actuation section **212** to operate the pump-action reload mechanism **200**.

Turning now to FIGS. 4A-4E, there is shown a first embodiment of a bolt carrier locking mechanism **400** useful in connection with the pump-action firearm **100** as shown in FIG. 1. The function of the bolt carrier locking mechanism **400** is to inhibit operation of the pump-action reload mechanism **200** when an unfired cartridge is in the chamber of barrel **130**. More particularly, the bolt carrier locking mechanism **400** inhibits the chamber from being partially opened, by pulling of the hand-held actuation arrangement **211** rearward when firing the firearm **100**, by mechanically interlocking with the bolt carrier **120**.

As shown, the bolt carrier locking mechanism **400** comprises a mechanical bolt carrier locking member **402** which inhibits (stops) rearward actuation of the pump-action reload mechanism **200** when an unfired cartridge is in the chamber of barrel **130**. The bolt carrier locking member **402** may be positioned in the receiver **110** in relationship to a known configuration (e.g. the AR-15/M16 configuration) of a hammer, trigger and bolt carrier/bolt, etc. When the firearm **100** is fired during normal operation, as the hammer **412** swings forward and begins to contact the bolt carrier locking member **402**, two wedge incline surfaces **414**, **416** of the front face of the hammer **412** impact and interact in sequence with two corresponding wedge incline surfaces **404**, **406** of the rear face of the bolt carrier locking member **402**, causing the bolt carrier locking member **402** to slide

laterally (transverse to a longitudinal axis of the bolt carrier **120** and the barrel **130**) and retract along pin **408** (to the left as looking down the barrel of the firearm **100**) out of the path of the hammer **412**.

After the hammer **412** is cocked during reloading and an unfired cartridge has been fully chambered, a spring **410** overlying pin **408**, which biases the lateral movement and retraction of the bolt carrier locking member **402**, positions the top portion **403** of bolt carrier locking member **402** relative to the bolt carrier **120** such that the bolt carrier **120** is prevented (mechanically blocked) from moving rearward upon an attempted rearward actuation of the pump-action reload mechanism **200** (see FIG. 4D as looking down the barrel of firearm **100**). Conversely, the top portion **403** of the bolt carrier locking member **402**, when unlocked, occupies a recess **420** formed in the side of the bolt carrier **120** (see FIG. 4E as looking down the barrel of firearm **100**).

In the event the chamber needs to be opened with the chamber containing an unfired cartridge, the operator of the firearm **100** may push the manual release button **430** located on the side of the firearm **100** to manually move the bolt carrier locking member **402** laterally relative to the bolt carrier **120** and thereafter pull the hand-held actuation arrangement **211** rearward.

Turning now to FIGS. 5A-5D, there is shown a second embodiment of a bolt carrier locking mechanism **500** useful in connection with the pump-action firearm **100** as shown in FIG. 1. Similar to the prior embodiment, the function of the bolt carrier locking mechanism **500** is to inhibit operation of the pump-action reload mechanism **200** when an unfired cartridge is in the chamber of barrel **130** and more particularly, the bolt carrier locking mechanism **500** inhibits the chamber from being partially opened in response to pulling of the hand-held actuation arrangement **211** rearward when firing the firearm **100** by mechanically interlocking with the bolt carrier **120**.

As shown, the bolt carrier locking mechanism **500** comprises a mechanical bolt carrier locking member **502** which inhibits (stops) rearward actuation of the pump-action reload mechanism **200** when an unfired cartridge is in the chamber of barrel **130**. The bolt carrier locking member **502** may be positioned in the receiver in relationship to a known configuration (e.g. the AR-15 configuration) of a hammer, trigger and bolt, etc. When the firearm **100** is fired during normal operation, as the hammer **512** swings forward, the surface **514** of the front face of the hammer **512** impacts surface **504** of the rear face of the bolt carrier locking member **502**, causing the bolt carrier locking member **502** to rotate clock-wise about pivot pin **508** (when viewed from the right (ejection) side of the firearm **100**) and the locking tab **503** of the bolt carrier locking member **502** to retract downward and disengage from a slotted recess **520** in the bottom of the bolt carrier **120**.

After the hammer **512** is cocked during reloading and a cartridge has been fully chambered, a spring **510** in front of pivot pin **508** biases the retraction and disengagement of the bolt carrier locking member **502** and forces the locking tab **503** of the bolt carrier locking member **502** to enter the slotted recess **520** in the bottom of the bolt carrier **120**. In the event the chamber needs to be opened with the chamber containing an unfired cartridge, the operator of the firearm **100** may push the manual release button **530** located on the bottom of the firearm **100** as part of the trigger guard.

As shown, the manual release button **530** comprises an elongated rod with an angled distal end surface **532** which opposing angled distal end surface **506** of bolt carrier locking member **502**. As such, when the manual release

button **530** is pushed, the angled distal end surface **532** of the manual release button **530** acts on the angled distal end surface **506** of bolt carrier locking member **502**, causing the bolt carrier locking member **502** to rotate clockwise about pivot pin **508** and the locking tab **503** of the bolt carrier locking member **502** to retract downward and disengage from a slotted recess **520** in the bottom of the bolt carrier **120**.

Turning now to FIGS. 6A-6C, there is shown an embodiment of a butt stock **140** useful in connection with a pump-action firearm **100** as shown in FIG. 1. Butt stock **140** according to the present disclosure may be used in with a wide variety of firearm configurations. This may include certain firearms in the AR-15 family of rifles, provided the return (buffer) spring is located somewhere other than the butt stock. Butt stock **140** comprises an elongated body **610** comprising a first elongated body member **620** and a second elongated body member **640**. As shown, the first elongated body member **620** and the second elongated body member **640** cooperate, and more particularly slide relative to one another, to provide an extendable (telescopic) elongated body **610**.

Butt stock **140** is fastened to the receiver of firearm **100** by a U-shaped mounting bracket assembly **622** which includes a first L-shaped bracket member **624** and a second L-shaped bracket member **626** which attach to opposing sides of the first elongated body **620**. First L-shaped bracket member **624** comprises a mounting portion **628** and a latching portion **630**, while second L-shaped bracket member **626** comprises a mounting portion **632** and a hinge portion **634**.

Butt stock **140** is configured to fold approximately 180 degrees to either side of the receiver **110**. In the illustrated exemplary embodiment, there are two opposing slots **650** machined in the receiver **110** to allow the hinge **634** and latch **630** to mount in and be secured with two screws **652** to opposite sides of the receiver **110**. The first elongated body **620** of the butt stock **140** is vertically symmetric.

Therefore, when the screws **652** are removed, the relative sides of the latch **630** and hinge **634** may be interchangeably replaced with one another by disassembling the first elongated body **620** from the second elongated body **640**, rotating the first elongated body **620** approximately 180 degrees around the longitudinal axis LA of the butt stock **140** and then reassembling the first elongated body **620** to the second elongated body **640**. As shown by FIG. 6A, the second elongated body **640** comprises opposing T-shaped tongue members **642** which are designed to fit with sliding engagement in opposing T-shaped groove members **636** formed in the first elongated body **620** to provide a tongue and groove sliding track.

As such, the latch **630** and hinge **634** can effectively change places by the butt stock **140** being disassembled and the first elongated body **620** flipped 180 degrees to alter the direction of the fold of the butt stock **140**. The butt stock **140** is also adjustable for length by rotating the release lever **644** which is attached to locking rod **646**, which will then rotate the locking rod **646** from an locked orientation to a unlocked orientation, at which time the second elongated body **640** may be slide rearward relative to the first elongated body **620** to lengthen the butt stock **140** or slide forward relative to the first elongated body **620** to shorten the butt stock.

Thus, the butt stock **140** is arrangeable in a first configuration to fold toward a first side of a receiver **110** of the firearm **100** into a first folded position along the first side of the receiver **110**, and unfoldable away from the first side of the receiver **110** of the firearm **100** into an unfolded position

rearward of the receiver **110**, as well as arrangeable in a second configuration to fold toward a second side of the receiver **110** of the firearm **100** into a second folded position along the second side of the receiver **110**, and unfoldable away from the second side of the receiver **110** of the firearm **100** into the unfolded position rearward of the receiver **110**.

While embodiments of the present invention have been described and illustrated herein, those of ordinary skill in the art will readily envision a variety of other means and/or structures for performing the functions and/or obtaining the results and/or one or more of the advantages described herein, and each of such variations and/or modifications is deemed to be within the scope of the present invention. More generally, those skilled in the art will readily appreciate that all parameters, dimensions, materials, and configurations described herein are meant to be exemplary and that the actual parameters, dimensions, materials, and/or configurations will depend upon the specific application or applications for which the teachings of the present invention is/are used. Those skilled in the art will recognize, or be able to ascertain using no more than routine experimentation, many equivalents to the specific embodiments of the invention described herein. It is, therefore, to be understood that the foregoing embodiments are presented by way of example only and that, within the scope of the appended claims and equivalents thereto, the invention may be practiced otherwise than as specifically described and claimed. The present invention is directed to each individual feature, system, article, material, kit, and/or method described herein. In addition, any combination of two or more such features, systems, articles, materials, kits, and/or methods, if such features, systems, articles, materials, kits, and/or methods are not mutually inconsistent, is included within the scope of the present invention.

All definitions, as defined and used herein, should be understood to control over dictionary definitions, definitions in documents incorporated by reference, and/or ordinary meanings of the defined terms.

The indefinite articles “a” and “an,” as used herein in the specification and in the claims, unless clearly indicated to the contrary, should be understood to mean “at least one.”

The phrase “and/or,” as used herein in the specification and in the claims, should be understood to mean “either or both” of the elements so conjoined, i.e., elements that are conjunctively present in some cases and disjunctively present in other cases. Other elements may optionally be present other than the elements specifically identified by the “and/or” clause, whether related or unrelated to those elements specifically identified, unless clearly indicated to the contrary.

What is claimed is:

1. A butt stock for a firearm comprising:

the butt stock arrangeable in a first configuration and a second configuration;

in the first configuration, the butt stock is configured to fold toward a first side of a receiver of the firearm into a first folded position along the first side of the receiver, and unfold away from the first side of the receiver of the firearm into an unfolded position rearward of the receiver; and

in the second configuration, the butt stock is configured to fold toward a second side of the receiver of the firearm into a second folded position along the second side of the receiver, and unfold away from the second side of the receiver of the firearm into the unfolded position rearward of the receiver.

13

2. The butt stock of claim 1 further comprising:  
a hinge; and  
wherein, in the first configuration of the butt stock, the  
hinge is disposed to the first side of the receiver; and  
wherein, in the second configuration of the butt stock, the  
hinge is disposed to the second side of the receiver. 5  
3. The butt stock of claim 2 wherein:  
the butt stock is connectable to the receiver by a mounting  
bracket member which includes the hinge.  
4. The butt stock of claim 2 further comprising: 10  
a latch; and  
wherein, in the first configuration of the butt stock, the  
latch is disposed to the second side of the receiver; and  
wherein, in the second configuration of the butt stock, the  
latch is disposed to the first side of the receiver. 15  
5. The butt stock of claim 4 wherein:  
the butt stock is connectable to the receiver by a mounting  
bracket member which includes the latch.  
6. The butt stock of claim 2 further comprising: 20  
an extendable elongated body comprising a first elongated  
body member and a second elongated body member;  
wherein the butt stock has a longitudinal axis; and  
wherein the first elongated body member includes a first  
side extending along the longitudinal axis, and a second  
side extending along the longitudinal axis opposite the  
first side; 25  
wherein the first side of the first elongated body member  
and the second side of the first elongated body member  
are transposed in the first configuration and the second  
configuration, respectively. 30  
7. The butt stock of claim 6 wherein:  
the second body member slides relative to the first body  
member to adjust a length of the butt stock.  
8. The butt stock of claim 7 wherein: 35  
the length of the butt stock is lockable by a locking  
mechanism.  
9. A firearm, comprising:  
a receiver;  
a barrel located at a forward end of the receiver; 40  
a butt stock located at a rearward end of the receiver;  
the butt stock arrangeable in a first configuration and a  
second configuration;  
in the first configuration, the butt stock is configured to  
fold toward a first side of the receiver of the firearm into  
a first folded position along the first side of the receiver, 45  
and unfold away from the first side of the receiver of  
the firearm into an unfolded position rearward of the  
receiver; and  
in the second configuration, the butt stock is configured to  
fold toward a second side of the receiver of the firearm

14

into a second folded position along the second side of  
the receiver, and unfold away from the second side of  
the receiver of the firearm into the unfolded position  
rearward of the receiver.  
10. A butt stock for a firearm comprising:  
the butt stock arrangeable in a first configuration to fold  
toward a first side of a receiver of the firearm into a first  
folded position along the first side of the receiver, and  
unfoldable away from the first side of the receiver of  
the firearm into an unfolded position rearward of the  
receiver;  
the butt stock arrangeable in a second configuration to  
fold toward a second side of the receiver of the firearm  
into a second folded position along the second side of  
the receiver, and unfoldable away from the second side  
of the receiver of the firearm into the unfolded position  
rearward of the receiver;  
a hinge and a latch;  
wherein, in the first configuration of the butt stock, the  
hinge is disposed to the first side of the receiver and the  
latch is disposed to the second side of the receiver;  
wherein, in the second configuration of the butt stock, the  
hinge is disposed to the second side of the receiver and  
the latch is disposed to the first side of the receiver;  
an extendable elongated body comprising a first elongated  
body member and a second elongated body member;  
wherein the second body member slides relative to the  
first body member to adjust a length of the butt stock;  
and  
the length of the butt stock is lockable by a locking  
mechanism.  
11. The butt stock of claim 2 further comprising:  
an extendable elongated body;  
wherein the butt stock has a longitudinal axis; and  
wherein the extendable elongated body includes a first  
side extending along the longitudinal axis, and a second  
side extending along the longitudinal axis opposite the  
first side; and  
wherein the first side of the extendable elongated body  
and the second side of the extendable elongated body  
are transposed in the first configuration and the second  
configuration, respectively.  
12. The butt stock of claim 11 wherein:  
wherein the first side of the extendable elongated body  
has a first side mounting structure configured to mount  
a mounting portion of a hinge; and  
wherein the second side of the extendable elongated body  
has a second side mounting structure configured to  
mount a mounting portion of a latch.

\* \* \* \* \*