



US010086537B2

(12) **United States Patent**  
**Shih et al.**

(10) **Patent No.:** **US 10,086,537 B2**  
(45) **Date of Patent:** **Oct. 2, 2018**

(54) **FLEXIBLE MANUFACTURE OF POLYMERIC TUBING**

(71) Applicants: **Jason Shih**, Yorba Linda, CA (US); **Andrew Dunn**, Santa Monica, CA (US); **Changgeng Liu**, South Pasadena, CA (US); **Brandon Curley**, Arcadia, CA (US)

(72) Inventors: **Jason Shih**, Yorba Linda, CA (US); **Andrew Dunn**, Santa Monica, CA (US); **Changgeng Liu**, South Pasadena, CA (US); **Brandon Curley**, Arcadia, CA (US)

(73) Assignee: **MINIPUMPS, LLC**, Pasadena, CA (US)

(\* ) Notice: Subject to any disclaimer, the term of this patent is extended or adjusted under 35 U.S.C. 154(b) by 270 days.

(21) Appl. No.: **14/271,979**

(22) Filed: **May 7, 2014**

(65) **Prior Publication Data**

US 2014/0332997 A1 Nov. 13, 2014

**Related U.S. Application Data**

(60) Provisional application No. 61/821,039, filed on May 8, 2013.

(51) **Int. Cl.**

**B29C 33/52** (2006.01)  
**B29C 64/188** (2017.01)  
**B29C 41/42** (2006.01)  
**B33Y 40/00** (2015.01)  
**B29C 33/00** (2006.01)  
**B29C 39/10** (2006.01)

(52) **U.S. Cl.**

CPC ..... **B29C 41/42** (2013.01); **B29C 33/0016** (2013.01); **B29C 33/52** (2013.01); **B29C 39/10** (2013.01); **B29C 64/188** (2017.08); **B33Y 40/00** (2014.12)

(58) **Field of Classification Search**

CPC ..... B29C 41/42; B29C 33/52; B29C 64/00; B29C 64/188

See application file for complete search history.

(56) **References Cited**

**U.S. PATENT DOCUMENTS**

4,364,067 A \* 12/1982 Koto ..... B41J 2/15  
347/40  
5,650,261 A \* 7/1997 Winkle ..... G03F 7/0045  
430/176  
8,349,233 B2 \* 1/2013 Ederer ..... B29C 71/0009  
264/109

(Continued)

**FOREIGN PATENT DOCUMENTS**

FR 2972956 A1 \* 9/2012 ..... B29C 33/52  
WO WO 0067981 A1 \* 11/2000 ..... B29C 33/3842

**OTHER PUBLICATIONS**

Machine translation of French Patent Publication No. FR-2972956 A1, originally published Sep. 2012, 12 pages.\*

*Primary Examiner* — William P Bell

(74) *Attorney, Agent, or Firm* — Morgan, Lewis & Bockius LLP

(57) **ABSTRACT**

Tubular polymeric structures are formed by creating a convex mold conforming to a fluid pathway design, depositing a coating of polymer over the mold, and in situ removing the mold without drawing it against the polymer.

**20 Claims, 4 Drawing Sheets**

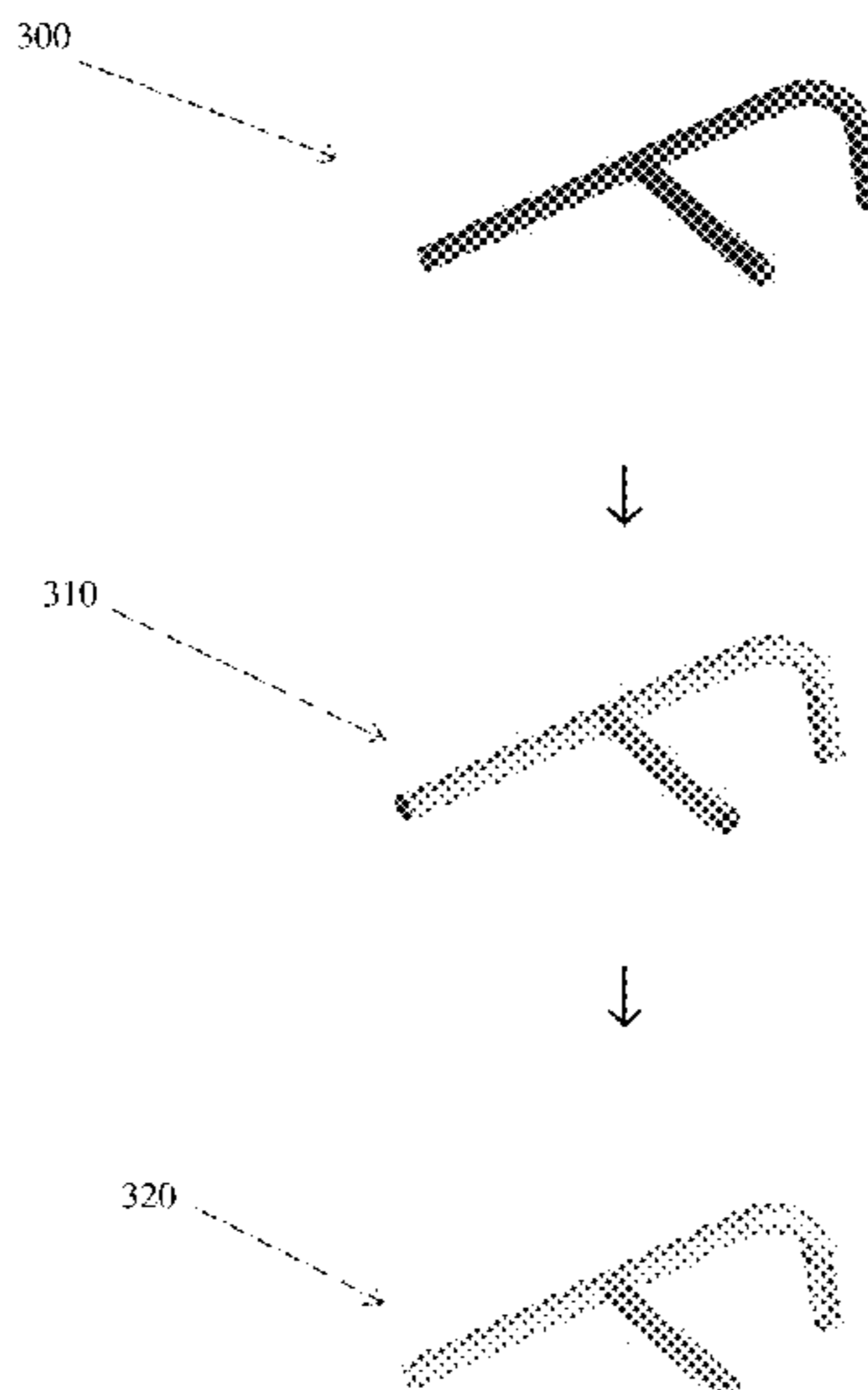

(56)

**References Cited**

U.S. PATENT DOCUMENTS

2002/0045265 A1\* 4/2002 Bergh ..... B01J 4/00  
436/37  
2003/0013935 A1\* 1/2003 Alferness ..... A61B 17/00234  
600/37  
2003/0111771 A1\* 6/2003 Gybin ..... B29C 67/0066  
264/400  
2003/0214057 A1\* 11/2003 Huang ..... B01J 19/0093  
264/1.1  
2005/0173838 A1\* 8/2005 Priedeman, Jr. .... B29C 67/0062  
264/401  
2007/0012891 A1\* 1/2007 Maltezos ..... B01L 3/502707  
251/12  
2008/0169585 A1\* 7/2008 Zinniel ..... B29C 71/0009  
264/401  
2014/0227437 A1\* 8/2014 DeBoer ..... B29D 11/00009  
427/162

\* cited by examiner

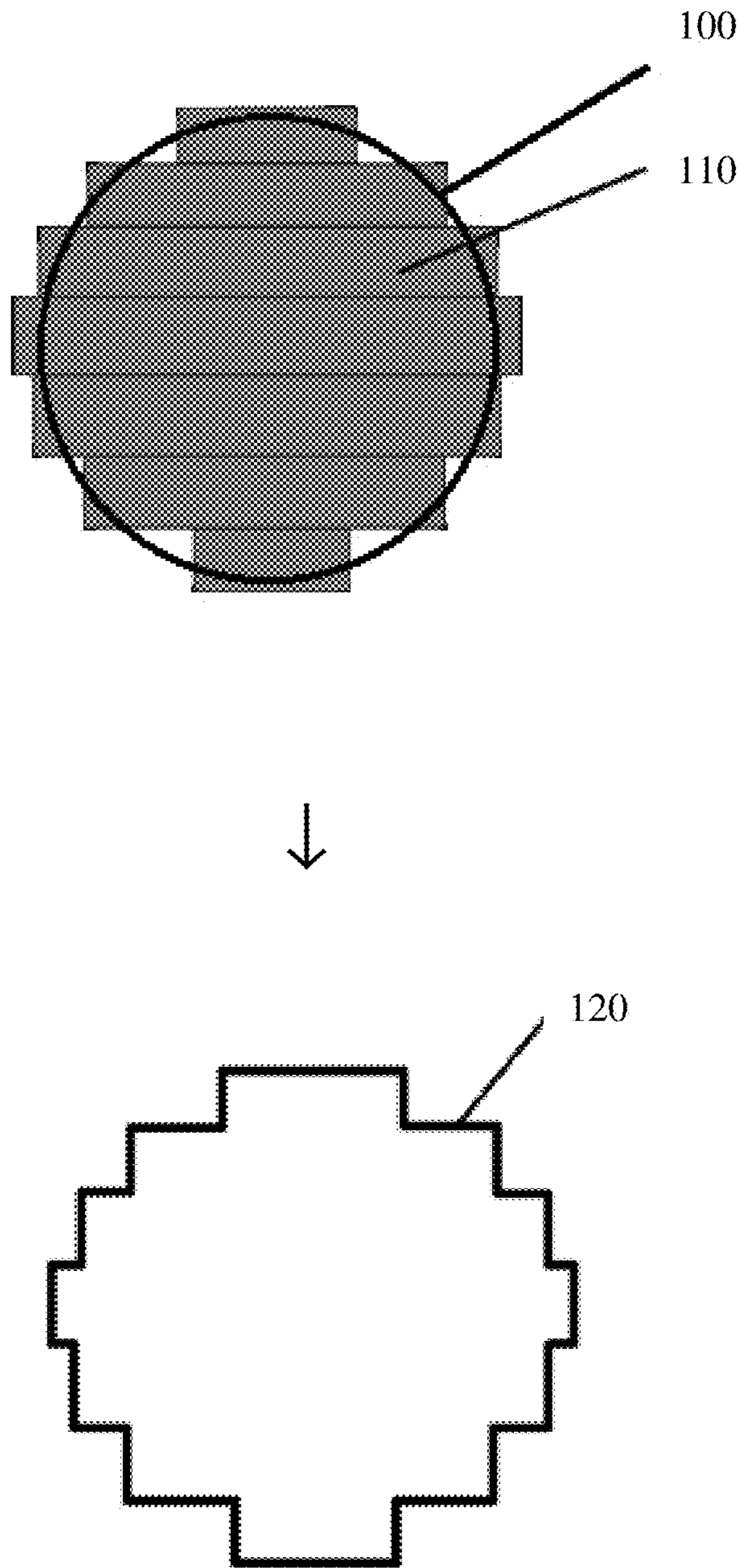

FIG. 1A

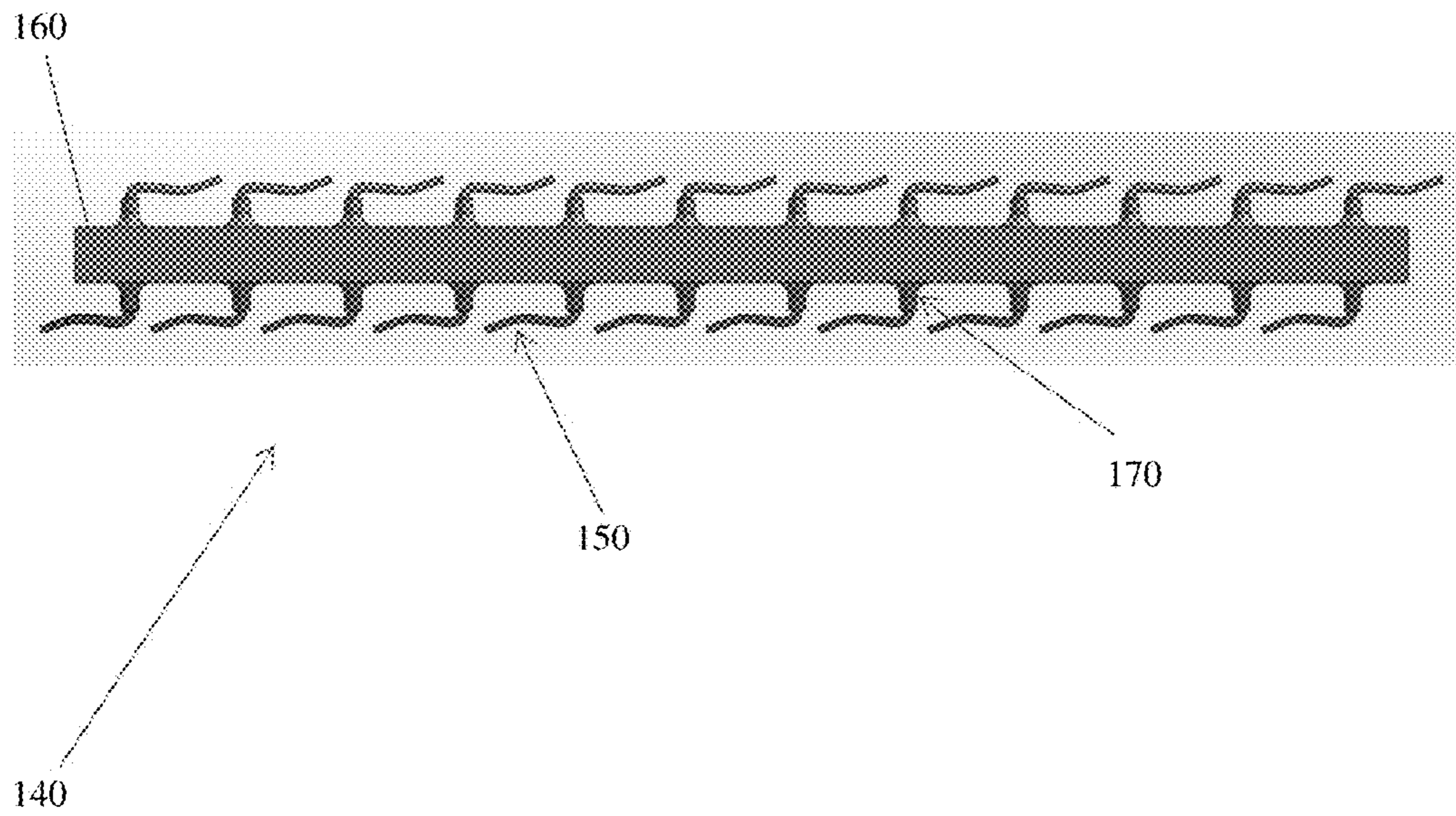

FIG. 1B

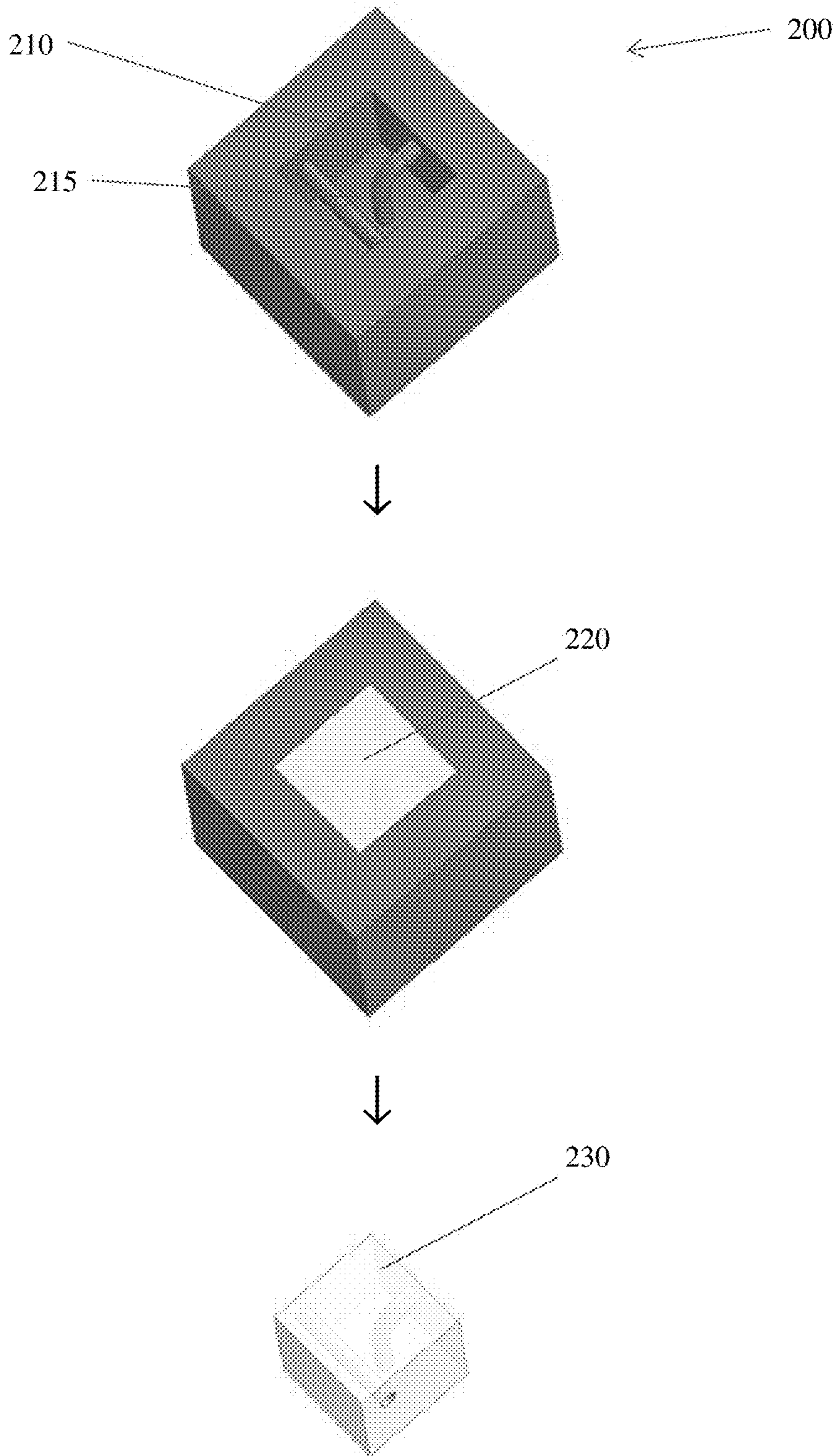

FIG. 2

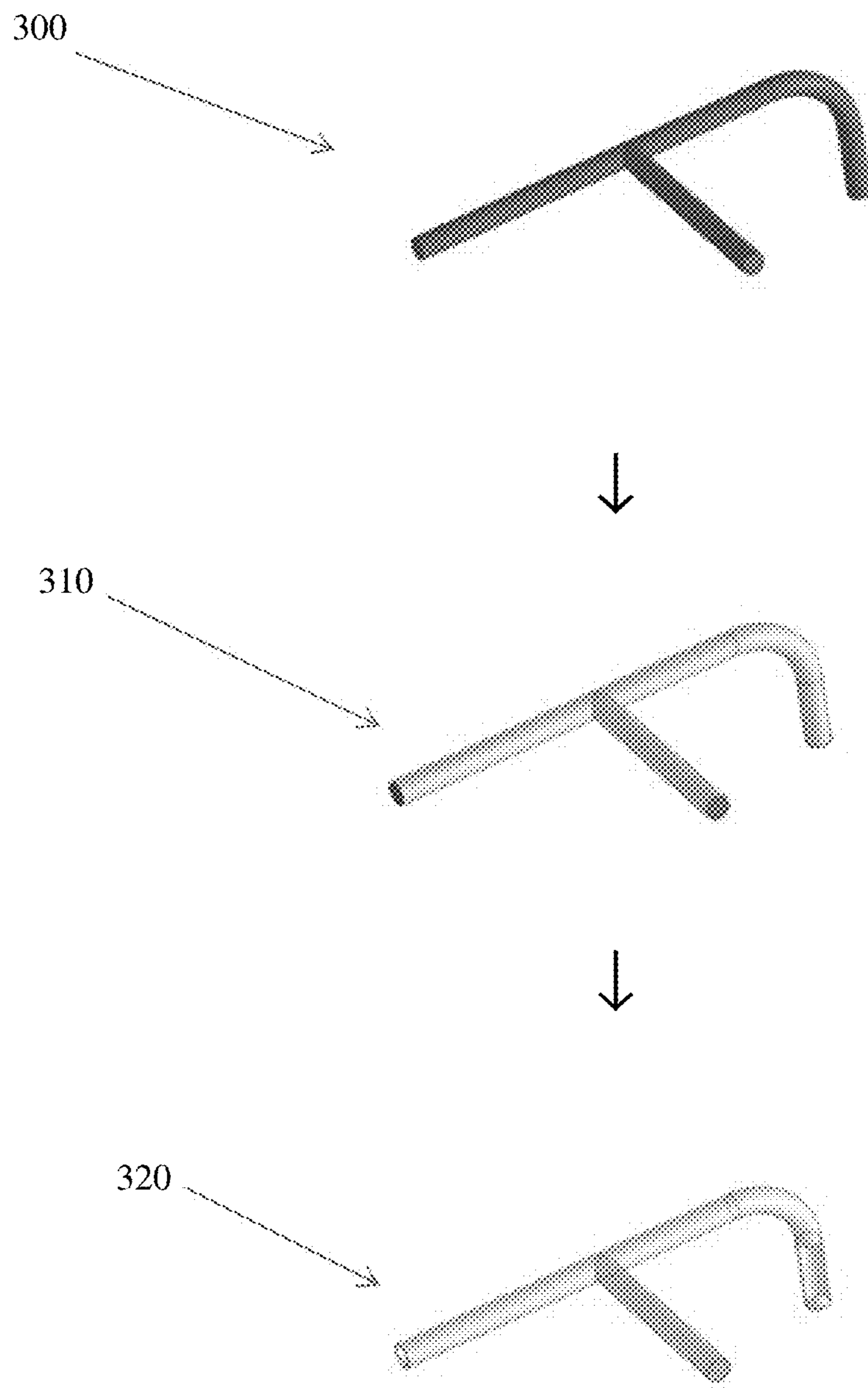

FIG. 3

1

## FLEXIBLE MANUFACTURE OF POLYMERIC TUBING

### CROSS-REFERENCE TO RELATED APPLICATION

This application claims priority to and the benefit of, and incorporates herein by reference in its entirety, U.S. Ser. No. 61/821,039, filed on May 8, 2013, the entire disclosure of which is hereby incorporated by reference.

### TECHNICAL FIELD

The present invention relates to microfluidic channels and methods for their manufacture, and more particularly to conduits capable of accommodating fluid paths with tight radii and varying cross-sections.

### BACKGROUND

The need for ever-smaller pumping devices, particularly in the medical field, continues to grow. As a result, the need for increasingly small operational pump components is growing as well, challenging the limits of conventional manufacturing processes. As fluidic devices shrink, it is necessary to manufacture fluidic paths with very tight radii and varying cross-sections to fit within the device package. Some of these cross-sections may not be round, and it may be necessary to form fluidic connectors directly into the fluid paths themselves.

Conventional manufacturing techniques have various limitations. One approach to creating polymeric fluidic paths is to use photoresist to create a channel in a layered polymer. Once the polymer has been layered over the photoresist, it is dissolved to leave a fluid channel; see, e.g., Jason Shih, 2008 "Microfabricated High-Performance Liquid Chromatography (HPLC) System With Closed-Loop Flow Control," Ph.D. thesis, Department of Mechanical Engineering, California Institute of Technology. Another approach is to use polymer extrusion to create small fluid channels; see, e.g., Lopez, Fernando L., 2011, "Micro-Sized Components for Medical Extrusion," Interface Catheter Solutions, California, USA. This is a standard method of fabrication for catheters and other macro-scale tubes. Although varying interior diameters and wall thicknesses are achieved by manipulating extrusion speed and die configurations, shapes such as tight-radius twists and bends are not easily replicable. A third approach is three-dimensional (3D) wax printing to create other types of structures for use in devices. This approach has been used to create relatively large 3D structures coated with very thin polymer layers; see, e.g., Feng, Guo-Hua and Kim, Eun Suk, 2003, "Universal Concept for Fabricating Micron to Millimeter Sized 3D Parylene Structures on Rigid and Flexible Substrates," *The Sixteenth Annual International Conference on Micro Electro Mechanical Systems*, 2003, pp. 594-597.

Unfortunately, conventional approaches such as these do not readily allow for the creation of fluid paths of a tortuous nature, having varying radii and minute dimensions, and with a smooth finish as necessary for long-term use, especially in implantable drug pumps. Smooth fluid paths within an implantable drug pump are generally necessary to avoid or minimize structures that promote drug aggregation, to reduce clogging, and to avoid long-term biofouling.

### SUMMARY

Manufacturing techniques in accordance herewith are capable of creating a wide array of fluidic paths that meet

2

demanding design criteria. Although the following discussion focuses on parylene (poly(p-xylylene)), it should be understood that the invention is applicable to many polymer systems, particularly those applied by vapor deposition, as will be apparent to those skilled in the art.

In one aspect, the invention pertains to a method of forming a tubular polymeric structure. In various embodiments, the method comprises the steps of forming a convex mold conforming to a fluid pathway design, the mold being formed of a material soluble in a solvent; depositing a coating of polymer over the mold to form a coated structure, the parylene being unaffected by exposure to the solvent; and in situ removing the mold by subjecting the coated structure to the solvent. In some embodiments, the material comprises or consists essentially of wax, whereas in other embodiments, the material comprises or consist essentially of a thermoplastic. The polymer may, for example, be parylene. The method may further include trimming one or more ends of the tubular polymeric structure to expose a lumen thereof.

In various embodiments, the mold is formed by 3D printing. For example, the mold may be formed into a block of support wax, in which case the method may further comprise dissolving the support wax but not the wax mold. In general, following deposition of the polymer, the mold is dissolved with a solvent that does not dissolve the polymer.

In various embodiments, prior to deposition of the polymer, the molds undergo a smoothing process. The smoothing process may, for example, comprise or consist essentially of passing a solvent vapor over the mold. Alternatively, the smoothing process may comprise or consist essentially of spin coating and baking photoresist over the mold. In still another alternative, the smoothing process may comprise or consist essentially of spray coating polyvinyl alcohol over the mold.

In alternative embodiments, the method comprises the steps of forming a convex mold conforming to a fluid pathway design; depositing a polymer coating over the mold to form a coated structure; and in situ removing the mold by heating the coated structure to a temperature sufficient to melt the mold but which does not damage the polymer. In some embodiments, the material comprises or consists essentially of wax, whereas in other embodiments, the material comprises or consist essentially of a thermoplastic. The polymer may, for example, be parylene. The mold may be formed by 3D printing.

In another aspect, the invention relates to a method of forming a parylene manifold structure. In various embodiments, the method comprises the steps of forming a mold having a cavity and, therein, a scaffold complementary to one or more fluid paths, the mold and the scaffold being formed of a material soluble in a solvent; filling the cavity with a polymer and causing the polymer to harden, the polymer being unaffected by exposure to the solvent; and in situ removing the mold including the scaffold by subjecting it to the solvent.

In some embodiments, alignment features are formed in the cavity. Following hardening of the polymer, the mold may be dissolved with a solvent that does not dissolve the polymer; alternatively (or in addition), following hardening of the polymer, the mold may be melted at a temperature that does not damage the polymer. Once again, the polymer may be parylene, and the method may further include trimming one or more ends of the tubular polymeric structure to expose a lumen thereof.

In yet another aspect, the invention relates to a method of forming a tubular polymer structure. In various embodi-

ments, the method comprises the steps of bending a wire to conform to a fluid pathway design; depositing a coating of polymer over the wire; and in situ removing the wire without drawing it against the polymer. In some embodiments, the wire is copper and the removing step comprises etching away the wire by exposure of the coated wire to an etchant; for example, the etchant may be ferrite chloride.

In some embodiments, the wire is made of a metal having a melting point lower than the melting point of the polymer (which may, for example, be parylene). For example, the wire may be Field's metal. The method may further comprise the step of shaping a cross-section of the wire prior to the depositing step.

As used herein, the term "substantially" or "approximately" means  $\pm 10\%$  (e.g., by weight or by volume), and in some embodiments,  $\pm 5\%$ . The term "consists essentially of" means excluding other materials that contribute to function, unless otherwise defined herein. Nonetheless, such other materials may be present, collectively or individually, in trace amounts.

Reference throughout this specification to "one example," "an example," "one embodiment," or "an embodiment" means that a particular feature, structure, or characteristic described in connection with the example is included in at least one example of the present technology. Thus, the occurrences of the phrases "in one example," "in an example," "one embodiment," or "an embodiment" in various places throughout this specification are not necessarily all referring to the same example. Furthermore, the particular features, structures, routines, steps, or characteristics may be combined in any suitable manner in one or more examples of the technology. The headings provided herein are for convenience only and are not intended to limit or interpret the scope or meaning of the claimed technology.

### BRIEF DESCRIPTION OF THE DRAWINGS

The foregoing will be more readily understood from the following detailed description of the invention, in particular, when taken conjunction with the drawings, in which:

FIG. 1A illustrates the results of a layered fabrication process for forming tubes in accordance with one embodiment;

FIG. 1B shows a scaffold for production of multiple similar fluid conduits in a single manufacturing sequence;

FIG. 2 illustrates fabrication of a solid manifold containing a fluid path in accordance with one embodiment; and

FIG. 3 illustrates fabrication of a branched-tube manifold in accordance with one embodiment.

### DETAILED DESCRIPTION

#### 1. Wire Mandrel Method

In one embodiment, a method of tube manufacture utilizes a metal (e.g., copper) wire to fabricate fluid paths with very good control of interior (lumen) dimension and excellent surface finish. In a representative embodiment, the process starts by cutting a length of copper wire having a diameter equal to that of the intended tube inner diameter (ID). The length of the cut copper wire is typically much longer than the length of tube being fabricated. If desired, the wire may be shaped using a pressing tool such as a jig that has been machined to correspond to the desired lumen geometry of the tube. For example, a wire with a round cross-section may be pressed in a jig so that its cross-section is a triangle, square or other polygon. Of course, any suitable machining (or other mechanical) technique may be used to

shape the wire, and indeed, wire having a desired cross-sectional shape and diameter may be obtainable commercially. Furthermore, other metals including platinum, tungsten, silver, and various alloys may be used in lieu of copper, but copper is preferred because the copper and ferrite chloride reaction does not generate gases as a byproduct. This makes etching easier without an additional process or the need to remove the gas generated by etching, which is inconvenient and may operate to inhibit the etching process.

The wire with the required cross-sectional geometry may be bent into a shape corresponding to the desired fluid routing path. The wire is then placed in a parylene deposition chamber and a layer of parylene of desired thickness (e.g., 20  $\mu\text{m}$ ) is deposited thereon, for example, by vapor deposition. After deposition, the parylene-coated wire is trimmed of polymer at both ends to expose the copper. The trimmed, coated wire is then placed in a solution that will dissolve the wire without harming the polymer coating; for example, in the case of a copper wire, a ferrite chloride solution can be used, typically requiring up to 3 weeks to fully remove the copper. At the end of the etching process only the parylene tube remains. The parylene tube may then be trimmed to the proper length for use.

This method allows for the creation of tubing with highly accurate internal dimensions as wire with a specifically engineered cross-section and consistent cross-section is used in the process. In addition, since the wire may have excellent surface finish, the resulting tube will have very smooth inner surfaces. Unlike extrusion, this method results in a rigid tube that is shaped to conform to the desired fluid path (as opposed to having to shape a straight tube). It may also create a tube with a round cross-section, which facilitates easy fluidic connections. The copper wire may be pre-machined to different cross-sectional shapes or varying radii to create further intricate structures.

In a variation of this approach, the wire is made of a bismuth, indium, and tin alloy (generally 32.5% Bi, 51% In, and 16.5% Sn) called a Field's metal. This soft metal can be shaped arbitrarily, but melts at 62° C. Accordingly, instead of using a chemical solution to remove the metal, the parylene-coated wire can be heated to the melting point of the metal, which will simply flow out of the tube. Once again, the wire may be pressed into a jig to give the wire the proper geometry, and following polymer deposition, the wire is clipped at both ends to allow the metal to flow out in the next step. A fixture may be used for accurate trimming. The coated wire is placed in an oven set for 62° C. and oriented upright. When the metal reaches 62° C. it melts, leaving only the polymer outer coating behind. The polymer tube is then trimmed to length for use.

This method creates tubing with a highly accurate internal diameter as wire with known tolerance is used in the process. In addition, since the wire has excellent surface finish, the resulting tube has very smooth inner surfaces. Unlike extrusion, this method results in a rigid tube that is shaped to the proper routing as opposed to having to affix a straight tube in the proper orientation. It can be used to create a tube with a round cross-section, which makes fluidic connections very easy to make. Unlike the copper wire method, the wire removal time is a matter of hours as opposed to weeks.

#### 2. 3D Mandrel Method of Tube Manufacture

A second manufacturing technique uses a material, such as wax, soluble in an organic (typically nonpolar) solvent as a 3D printing material to build a convex mold or scaffold onto which a controlled-thickness layer of a polymer such as parylene C is deposited; the polymer is unaffected by the



solvent. As used herein, the term “wax” refers broadly to any lipid compound (or mixture of compounds) that is solid at room temperature. Typically, the molecular structure of a wax consists of or comprises long alkyl chains that may or may not have functional groups, and that may include intrachain linkages such as ester linkages. Waxes may be natural or synthetic, and may be a single component or a blend of components. Furthermore, other materials such as thermoplastics or organic mixtures may be used as the printing material so long as they are soluble in a suitable solvent. While the ensuing discussion refers to wax for ease of explanation, it should be understood that these alternative materials may be used instead.

The geometry and cross-section of the structure may be created by building up layers of wax to create any arbitrary shape. Following deposition of the parylene onto the mold, the wax is dissolved, leaving only the outer layer of deposited parylene. The result is a tube of controlled wall thickness and accurately controlled cross-section and geometry.

The wax scaffold may be formed in any suitable manner, including, without limitation, molding, extrusion, or selective, layer-by-layer deposition onto a surface in a manner that builds up a 3D structure—a process often termed “3D printing.” This wax-scaffold approach to tube fabrication allows for the manufacture of parylene tubes of arbitrary cross-section and routing with very accurate dimensional control. In a representative embodiment, illustrated in FIG. 1A, a 3D wax printer is used to build up the wax scaffold within a block of support wax. The shape and size of a desired cross-section **100** is defined, and a series of flat, elongated wax layers **110** (e.g., having a thickness of 6.35  $\mu\text{m}$ ) is sequentially deposited. The layers **110** may follow a tortuous path but along the dimension of deposition roughly conform, collectively, to the cross-section **100**—that is, the layers **110** fit as snugly as possible within the envelope defined by the cross-section **100**.

Once printed, the resulting wax tube mold **120** has a rough and stepped appearance from the layered addition of wax material during the printing process. This can cause the subsequently deposited polymer to be rough and opaque in appearance. To improve the surface finish, a smoothing process is desirably performed on the printed wax molds. One such method is using a solvent vapor such as acetone to smooth the tube molds. Using a convective air current to pass a solvent vapor over the molds, the top layer of wax is softened and reflows over the surface. The resulting mold surface finish is smooth without loss of the material.

The support wax melts at a lower temperature than the deposited wax—for example, the support wax may be a wax mixture (e.g., a naturally produced wax) while the deposited wax may be paraffin. The support block retains the printed wax parts as they are built up in order to prevent them from breaking apart prior to completion. Once the printing is complete, the structure is heated to a temperature sufficient to melt the support wax but low enough to leave the printed wax unaffected (or, alternatively, the structure is subjected to a solvent that dissolves the support wax but not the deposited wax). For example, certain forms of bee’s wax melt at 30° C., paraffin may melt at approximately 55° C., and synthetic waxes may have melting points as high as 75° C. Using readily available equipment, 3D printing can be controlled to an accuracy of 25.4  $\mu\text{m}$  and can fabricate a minimum feature size of 254  $\mu\text{m}$ ; suitable 3D printers include the SOLIDSCAPE T76Plus device marketed by Solidscape Inc., Merrimack, N.H. and the ProJet 3500 series of devices marketed by 3D Systems, Inc., Rock Hill, S.C. The support

block may itself be printed or may instead be molded in the form of a block with a recess, the bottom surface of which receives the deposited wax.

An alternative smoothing technique for the wax tube molds utilizes a microelectromechanical system (MEMS) approach. First, a photoresist such as SU-8 is spin-coated onto the printed wax molds. The solvent in the photoresist acts to dissolve away any defects while the resist itself helps to fill the surface steps in the wax mold. Several iterations of the spin coating may be required to achieve the final desired surface finish. The resist is then baked on the molds to evaporate the solvent and harden the resist. This step creates an even surface finish over the entire mold surface while maintaining the shape and size of the tube mold.

In specific applications, it may be desired to create a slightly smaller-diameter tube. By increasing the solvent composition, concentration, or spin coating time, the wax tube may be reduced in size in a controlled fashion by, for example, 5% or 10%. Such an approach can beneficially reduce the size of the tube to dimensions below the capability of the wax printer while also smoothing the surface. For example, a 200  $\mu\text{m}$  diameter structure may be out of the range of the wax printer, which produces (for example) a 230  $\mu\text{m}$  structure with a rough surface of 10  $\mu\text{m}$ . By increasing the photoresist contact duration, the wax mold can be smoothed and reduced to obtain the target 200  $\mu\text{m}$  diameter structure.

The second step addresses the opacity of the parylene after deposition. After spinning and baking the SU-8 photoresist, a thin layer of polyvinyl alcohol (PVA) solution may be sprayed on the photoresist coated molds. The PVA gives a shine to the molds that causes the deposited parylene to be transparent. Several coats of PVA solution may be required to achieve the desired shine on the wax molds.

The smoothing process may also be used for extra dimensional control of the wax molds when, once again, the required dimensions or tolerances cannot be created or maintained by the wax printer itself. Allowing the SU-8 photoresist to remain on the surface of the mold before baking for a longer time period will reduce the size of the mold features. This facilitates incorporation of features that are smaller than the minimum size achievable using available 3D printing technology. Increasing the time the SU-8 photoresist remains on the mold during spinning from 10 up to 20 seconds decreases the feature size by 10%-15% from the 3D printed dimension. By adjusting this spin time, very accurate dimensional changes and control can be achieved.

Once the mold is smoothed, it is placed in a parylene deposition chamber in which a controlled thickness (e.g., 20  $\mu\text{m}$ ) of a polymer (e.g., parylene C) is deposited on the surface. After parylene deposition, the ends of the resulting tubular structure are clipped to expose the wax on each end to the outside environment. A fixture may be used for accurate trimming. The structure is then placed in acetone or another other suitable solvent to dissolve away the wax mold from the inside. After 24-48 hours of soak time in acetone, only the parylene outer layer remains.

Unlike other tube manufacturing methods, 3D printing as described herein easily allows for production of tubes of virtually any shape, diameter, and routing. FIG. 1B illustrates how a single scaffold **140** may be used to create a plurality of tubes in a single batch run without additional handling. The molds **150** for the individual tubes may each be anchored to the scaffold **160** by a mold segment **170** that produces a fluidic connector. In use following fabrication, the fluidic connector is used to connect the tubing segment to a conduit (e.g., another tubing segment). The fluidic connector

may have a specific cross-sectional geometry (e.g., off-round, polygonal, etc.) to align and connect the tube to an adjacent conduit.

The connector portion typically has a wider diameter than the tube, which serves to sturdy the point of attachment to the scaffold **160**, and in some embodiments, the mold segments **170** flare where they are joined to the scaffold **160** in order to increase the surface area of contact with the scaffold and provide further sturdiness to the mold, thereby avoiding inadvertent removal of the molds during manufacture. The flared segment may or may not be part of the finished tube; that is, it may be cut away from the connector or represent a part of it. For example, a conically flared connector portion can provide stress relief when the tube is connected to another conduit.

Following polymer application and cure, the resulting polymer tubes may be cut away from the scaffold **160**, and the distal end of each tube may be removed to expose the lumen. The tubes may be subjected to the action of a solvent at this point, but in some embodiments, this occurs while the molds **170** are still adhered to the scaffold **160**, which resists the action of the solvent that removes the molds **150** (and so can be re-used). The wax printing method for tube production provides highly accurate tubing structures with minimal manual handling and manufacturing.

### 3. Solid Manifold Method of Tube Manufacture

The present invention may be used to form a solid manifold with internal fluid paths. A solid manifold is critical for some microfluidic configurations (e.g., modular designs assembled from interchangeable fluid-path components), and more generally offer increased tubing strength, ease of handling, and ease of component integration. By utilizing the flexibility of wax printing technology, manifolds of nearly any configuration can be made. A representative fabrication sequence is shown in FIG. **2**. First, a wax mold **200** is printed, molded or otherwise fabricated with an internal cavity **210**. Within the cavity **210**, a wax structure corresponding to the desired tubing configuration(s) **215** is printed. Next, the cavity **210** is filled with a liquid form of the material **220** that will compose the manifold, e.g., a curable polymeric material such as parylene, silicone or epoxy. After the material **220** is cured (e.g., by exposure to actinic radiation or e-beam, or simply by allowing it to dry and harden), the wax is removed from the finished structure to create the solid manifold **230** containing internal microfluidic passages complementary to the wax structure **215**. The wax may be removed from the manifold **230** by heating it to the melting point of the wax and allowing to flow out of the manifold (assisted by an air jet if needed), or by subsection to a solvent for the wax. The more the manifold is cross-linked, the greater will be useful range of solvents, since few solvents will harm a fully cross-linked polymer. The original wax mold **215** may contain additional structural features (pins, slots, indents, partial tubes, grooves, etc.) to help align and connect the tube set with an adjacent component during component integration.

### 4. Branched Tube Manifold Method of Tube Manufacture

As illustrated in FIG. **3**, a branched tube manifold may be created to consolidate the number of connections as well as reduce the space required for fluidic connections. In a representative fabrication sequence, a wax mold **300** with extensions along multiple fluidic paths is molded or printed. The surface of the wax mold **300** is preferably smoothed as described above. Next, the wax mold is coated with a polymer such as parylene to form a coated structure **310**.

Finally, the wax mold is heated or dissolved away, leaving parylene tubing **320** conforming to the fluid path defined by the mold **300**.

Various embodiments of the invention are described above. It will, however, be apparent to those of ordinary skill in the art that other embodiments incorporating the concepts disclosed herein may be used without departing from the spirit and scope of the invention. Accordingly, the above description is intended to be only illustrative and not restrictive.

What is claimed is:

1. A method of forming a tubular polymeric structure, the method comprising the steps of:

forming a convex mold conforming to a fluid pathway design, the mold being formed of a material soluble in a first solvent;

determining an amount of a size that the mold is to be reduced;

determining at least one of a concentration of a second solvent in a photoresist or a baking time of the photoresist based at least in part on the determined amount of the size to be reduced;

performing a smoothing process by spin coating and baking the photoresist over the mold so as to reduce the size of the mold based on the determined at least one of the concentration of the second solvent or the baking time of the photoresist;

depositing a coating of polymer over the mold to form a coated structure, the polymer being unaffected by exposure to the first solvent; and  
in situ removing the mold by subjecting the coated structure to the first solvent.

2. The method of claim **1** wherein the material is wax.

3. The method of claim **2** wherein the mold is formed into a block of support wax, and further comprising the step of dissolving the support wax but not the wax mold.

4. The method of claim **1** wherein the material is a thermoplastic.

5. The method of claim **1** wherein the polymer is parylene.

6. The method of claim **1** wherein the mold is formed by 3D printing.

7. The method of claim **1** wherein the smoothing process comprises spray coating polyvinyl alcohol over the mold.

8. The method of claim **1** further comprising trimming one or more ends of the tubular polymeric structure to expose a lumen thereof.

9. The method of claim **1**, wherein the mold undergoes iterations of the spin coating to achieve a final surface finish.

10. A method of forming a tubular polymeric structure, the method comprising the steps of:

forming a convex mold conforming to a fluid pathway design;

determining an amount of a size that the mold is to be reduced;

determining at least one of a concentration of a solvent in a photoresist or a baking time of the photoresist based at least in part on the determined amount of the size to be reduced;

performing a smoothing process by spin coating and baking the photoresist over the mold so as to reduce the size of the mold based on the determined at least one of the concentration of the solvent or the baking time of the photoresist;

depositing a polymer coating over the mold to form a coated structure; and

9

in situ removing the mold by heating the coated structure to a temperature sufficient to melt the mold but which does not damage the polymer.

11. The method of claim 10 wherein the material is wax.

12. The method of claim 10 wherein the material is a thermoplastic.

13. The method of claim 10 wherein the polymer is parylene.

14. The method of claim 10 wherein the mold is formed by 3D printing.

15. The method of claim 10 further comprising trimming one or more ends of the tubular polymeric structure to expose a lumen thereof.

16. A method of forming a polymer manifold structure, the method comprising the steps of:

forming a mold having a cavity and, therein, a scaffold complementary to one or more fluid paths;

determining an amount of a size that the mold is to be reduced;

determining at least one of a concentration of a solvent in a photoresist or a baking time of the photoresist based at least in part on the determined amount of the size to be reduced;

10

performing a smoothing process by spin coating and baking the photoresist over the mold so as to reduce the size of the mold based on the determined at least one of the concentration of the solvent or the baking time of the photoresist;

filling the cavity with a polymer and causing the polymer to harden; and

in situ removing the mold including the scaffold.

17. The method of claim 16 wherein alignment features are formed in the cavity.

18. The method of claim 16 wherein the mold and the scaffold are formed of a material soluble in a second solvent, the polymer is unaffected by exposure to the second solvent, and, following hardening of the polymer, the mold is dissolved with the second solvent that does not dissolve the polymer.

19. The method of claim 16 wherein, following hardening of the polymer, the mold is melted at a temperature that does not damage the polymer.

20. The method of claim 16 wherein the polymer is parylene.

\* \* \* \* \*