

US010069372B2

(12) **United States Patent**
Furutachi

(10) **Patent No.:** **US 10,069,372 B2**
(45) **Date of Patent:** **Sep. 4, 2018**

(54) **MOTOR**

(71) Applicant: **Nidec Corporation**, Kyoto (JP)

(72) Inventor: **Eiji Furutachi**, Kyoto (JP)

(73) Assignee: **NIDEC CORPORATION**, Kyoto (JP)

(*) Notice: Subject to any disclaimer, the term of this patent is extended or adjusted under 35 U.S.C. 154(b) by 285 days.

(21) Appl. No.: **14/874,596**

(22) Filed: **Oct. 5, 2015**

(65) **Prior Publication Data**

US 2016/0079819 A1 Mar. 17, 2016

Related U.S. Application Data

(63) Continuation of application No. 14/821,946, filed on Aug. 10, 2015.

(30) **Foreign Application Priority Data**

Sep. 17, 2014 (JP) 2014-188358

Mar. 31, 2015 (JP) 2015-073138

(51) **Int. Cl.**

H02K 1/04 (2006.01)

H02K 5/16 (2006.01)

(Continued)

(52) **U.S. Cl.**

CPC **H02K 5/161** (2013.01); **H02K 1/2773** (2013.01); **H02K 1/30** (2013.01); **H02K 5/1735** (2013.01); **H02K 9/06** (2013.01); **H02K 11/0068** (2013.01)

(58) **Field of Classification Search**

CPC H02K 1/2773; H02K 1/30; H02K 5/1735; H02K 5/161; H02K 11/0068

(Continued)

(56) **References Cited**

U.S. PATENT DOCUMENTS

2,220,032 A 10/1940 Winther et al.

4,227,105 A 10/1980 Kumakura

(Continued)

FOREIGN PATENT DOCUMENTS

DE 10 2012 212 157 A1 1/2014

JP 49-038910 U1 7/1972

(Continued)

OTHER PUBLICATIONS

Furutachi, E. et al.; "Motor"; U.S. Appl. No. 14/849,862, filed Sep. 10, 2015.

(Continued)

Primary Examiner — Hanh Nguyen

(74) *Attorney, Agent, or Firm* — Keating & Bennett, LLP

(57) **ABSTRACT**

The motor comprises a rotary unit, a stationary unit disposed around the rotary unit, and a bearing mechanism. The rotary unit comprises a plurality of magnets, a rotor core, a resin portion which covers the plurality of magnets and the rotor core. The rotor core comprises a ring-shaped inner core portion disposed at a radially inner side of the plurality of magnets, an outer core portion, and a plurality of connecting portions which radially connects the plurality of core elements, which are disposed between the plurality of magnets, and the inner core portion. The resin portion comprises an upper resin portion and a lower resin portion. The upper resin portion includes a plurality of gate holes. The lower resin portion is disposed at a more radially inner side than the plurality of outer core elements, and further comprises a first core support mark which exposes a part of the bottom surface of the rotor core, and a second core support mark disposed in the outer core part, and exposes a part of the bottom surface of the rotor core.

21 Claims, 5 Drawing Sheets

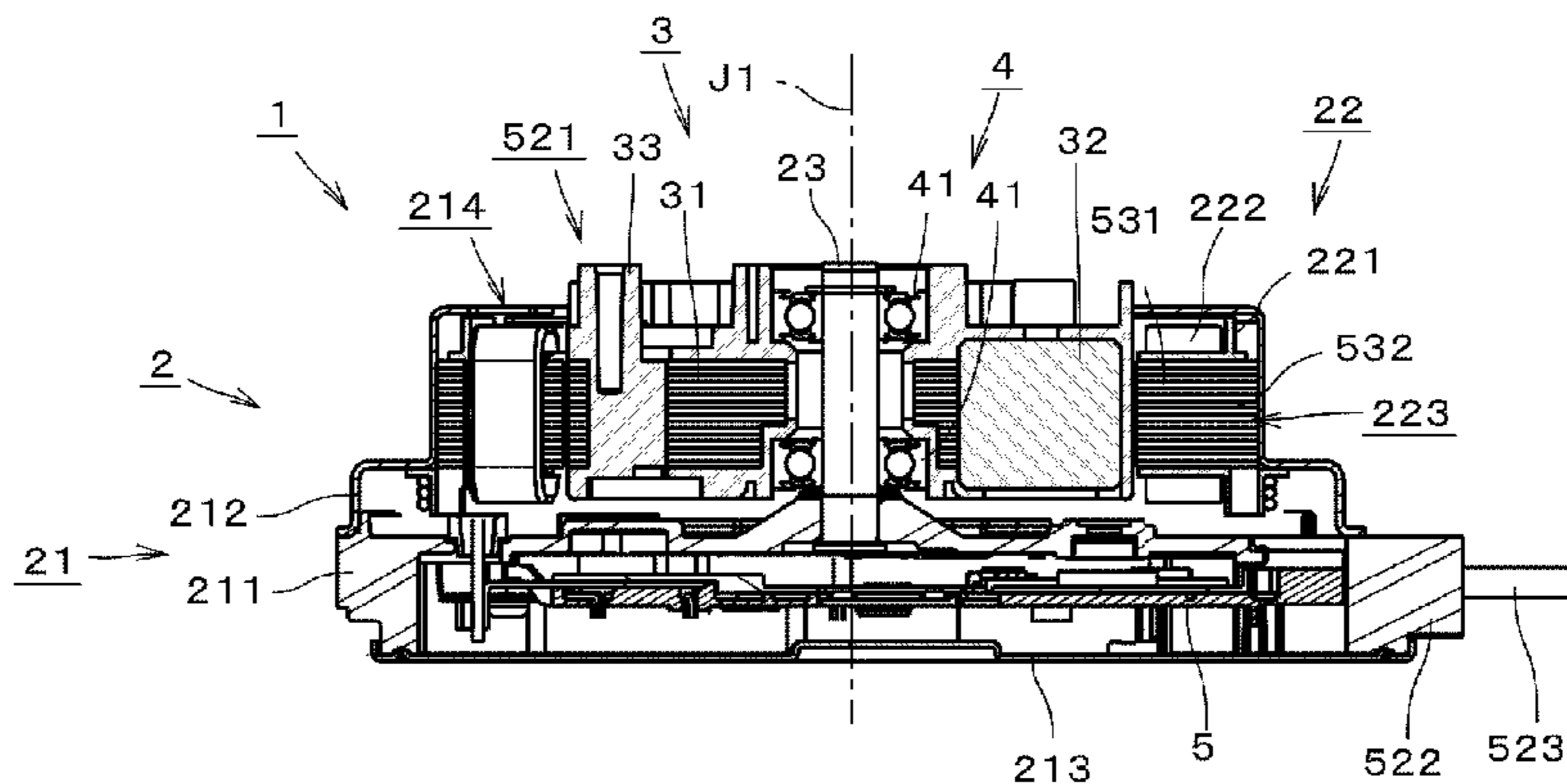

- | | | | | | | |
|------|-------------------|-----------|------------------|--------|--------------------|-------------|
| (51) | Int. Cl. | | 2007/0018521 A1* | 1/2007 | Ishiguro | F04D 29/043 |
| | <i>H02K 1/27</i> | (2006.01) | | | | 310/156.43 |
| | <i>H02K 9/06</i> | (2006.01) | 2008/0193275 A1 | 8/2008 | De Filippis et al. | |
| | <i>H02K 11/00</i> | (2016.01) | 2014/0042834 A1* | 2/2014 | Asahi | H02K 1/04 |
| | <i>H02K 1/30</i> | (2006.01) | | | | 310/43 |
| | <i>H02K 5/173</i> | (2006.01) | 2014/0042854 A1 | 2/2014 | Asahi et al. | |
| | | | 2016/0197535 A1 | 7/2016 | De Filippis et al. | |

- (58) **Field of Classification Search**
 USPC 310/43, 156.01–156.84
 See application file for complete search history.

FOREIGN PATENT DOCUMENTS

- (56) **References Cited**
 U.S. PATENT DOCUMENTS

JP	59-085064 U	6/1984
JP	2013-110780 A	6/2013
JP	2013-236417 A	11/2013

OTHER PUBLICATIONS

6,227,822 B1	5/2001	Chen	
7,091,644 B2	8/2006	Fukushima et al.	
7,679,252 B2*	3/2010	Iwase	H02K 1/276
			310/156.05
8,922,083 B2*	12/2014	Asahi	H02K 1/2706
			310/156.08

Furutachi, "Motor", U.S. Appl. No. 14/821,946, filed Aug. 10, 2015.

* cited by examiner

FIG. 1

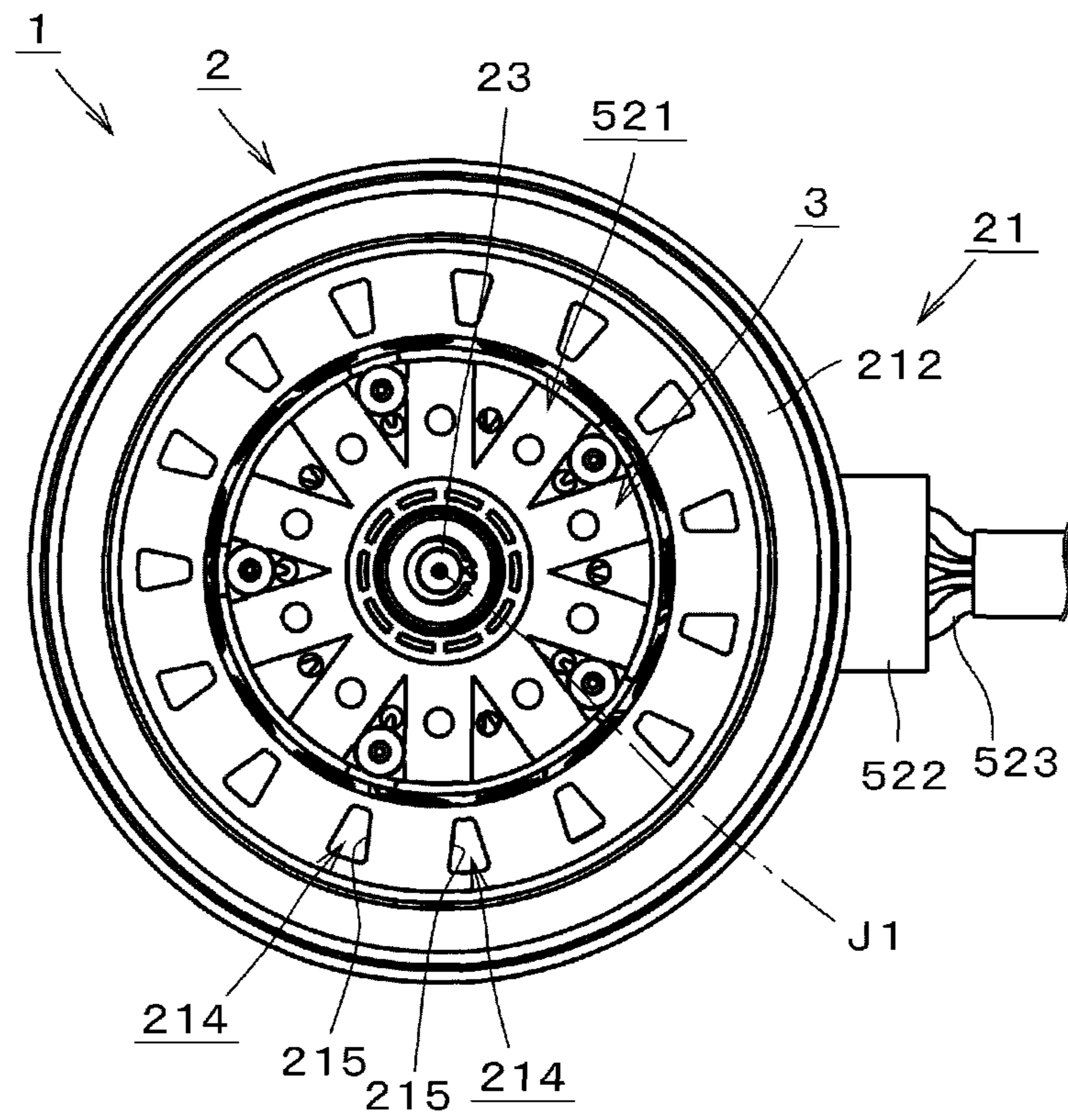

FIG. 2

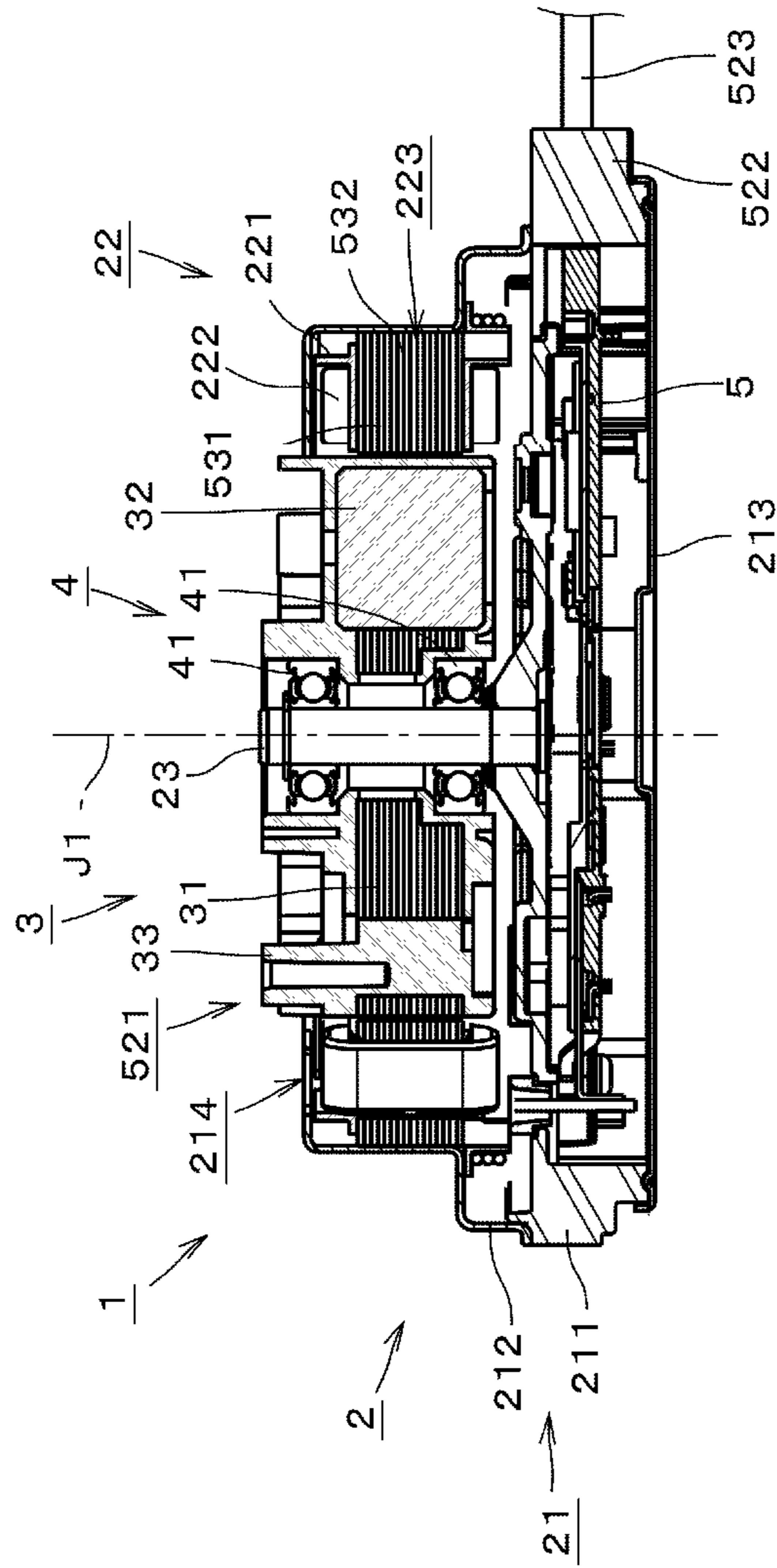

FIG. 3

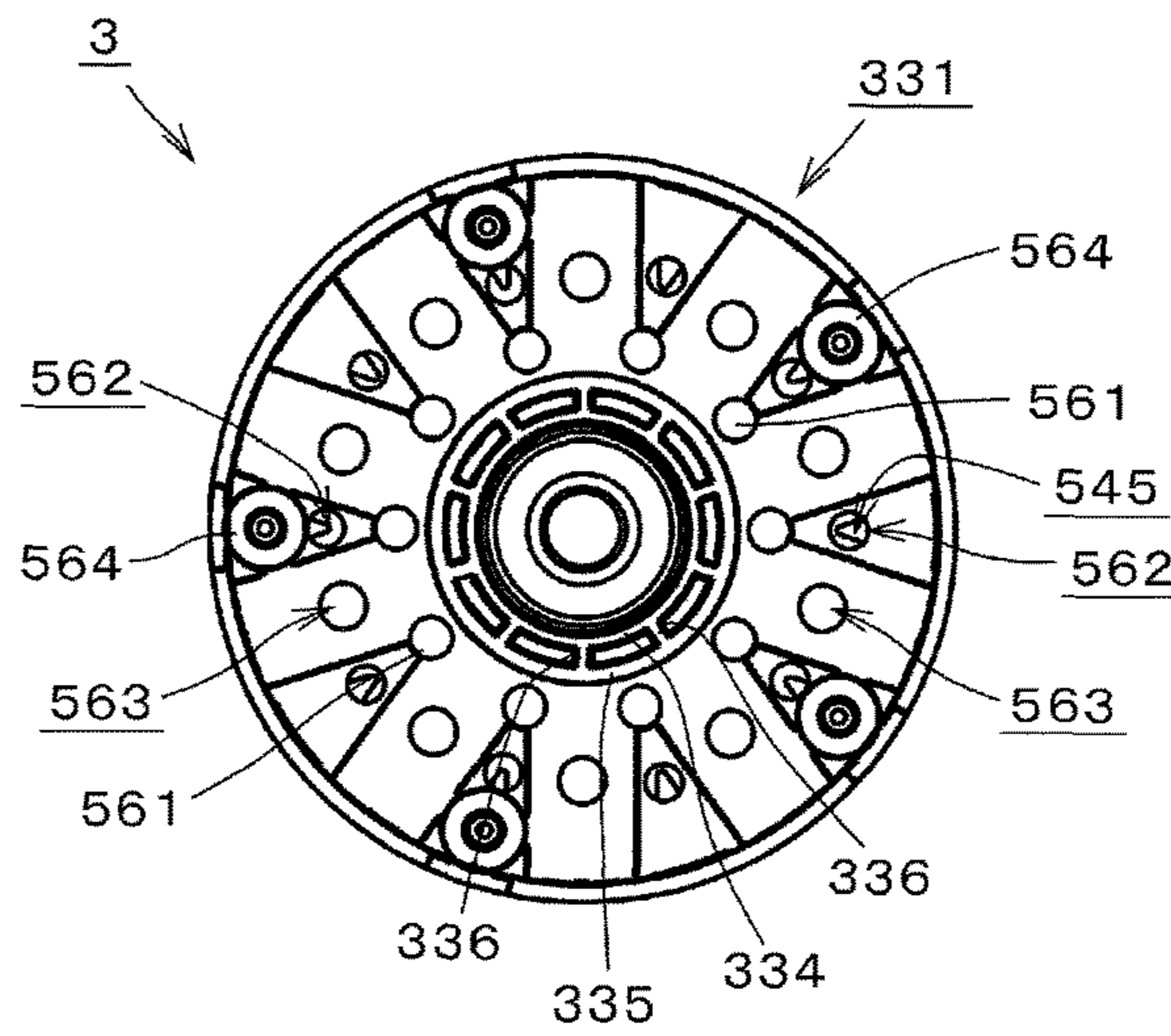

FIG. 4

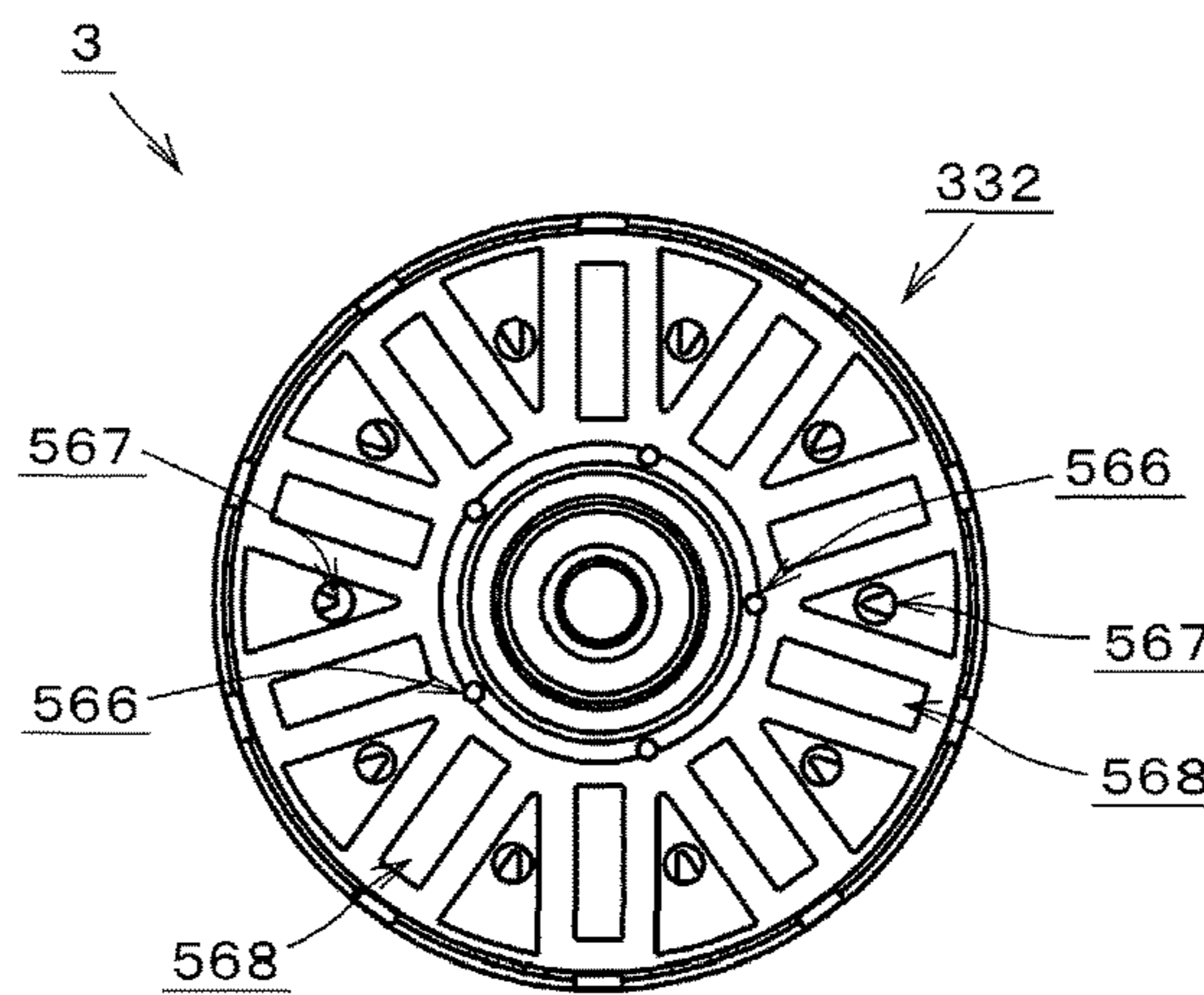

FIG. 5

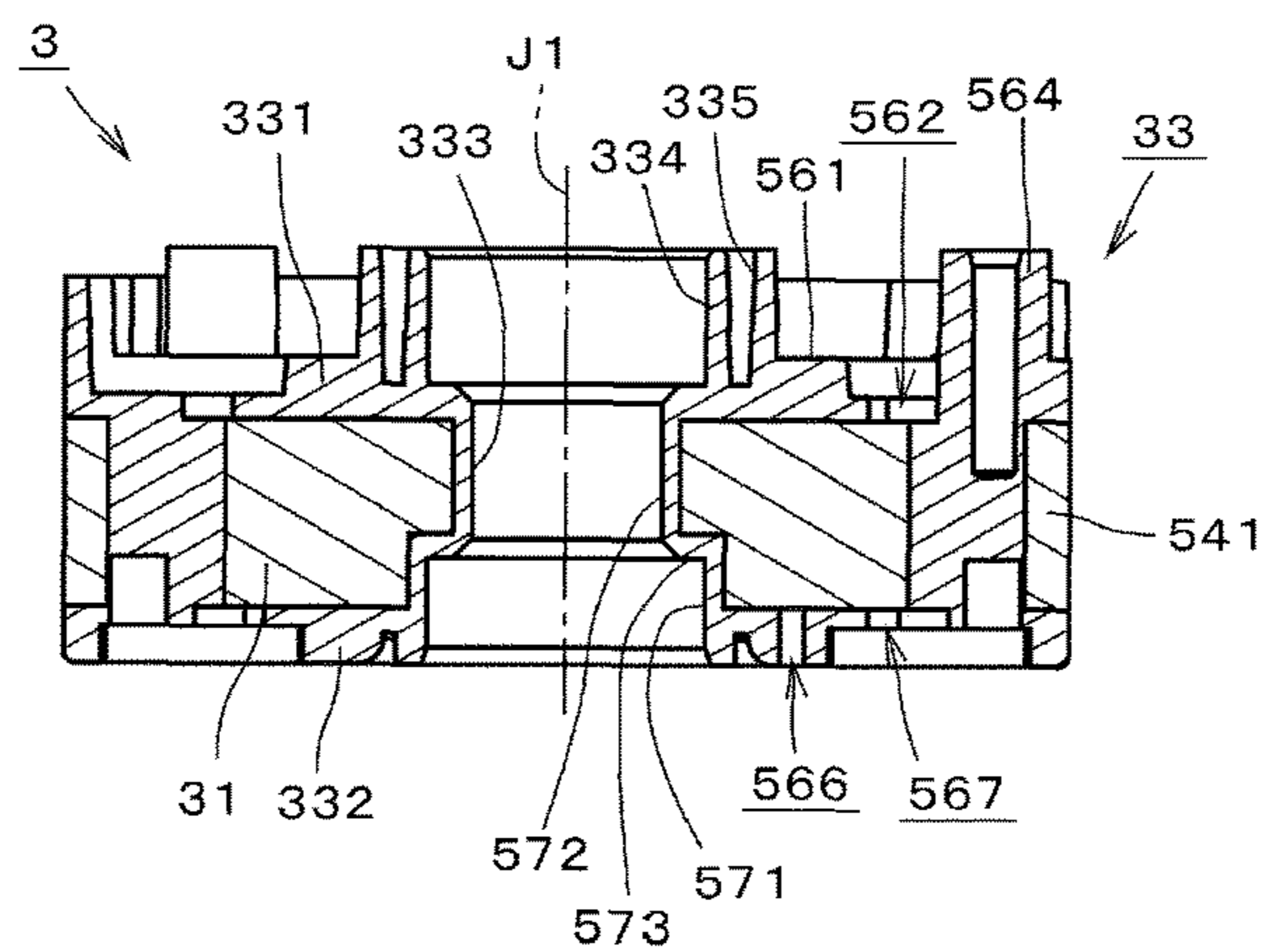

FIG. 6

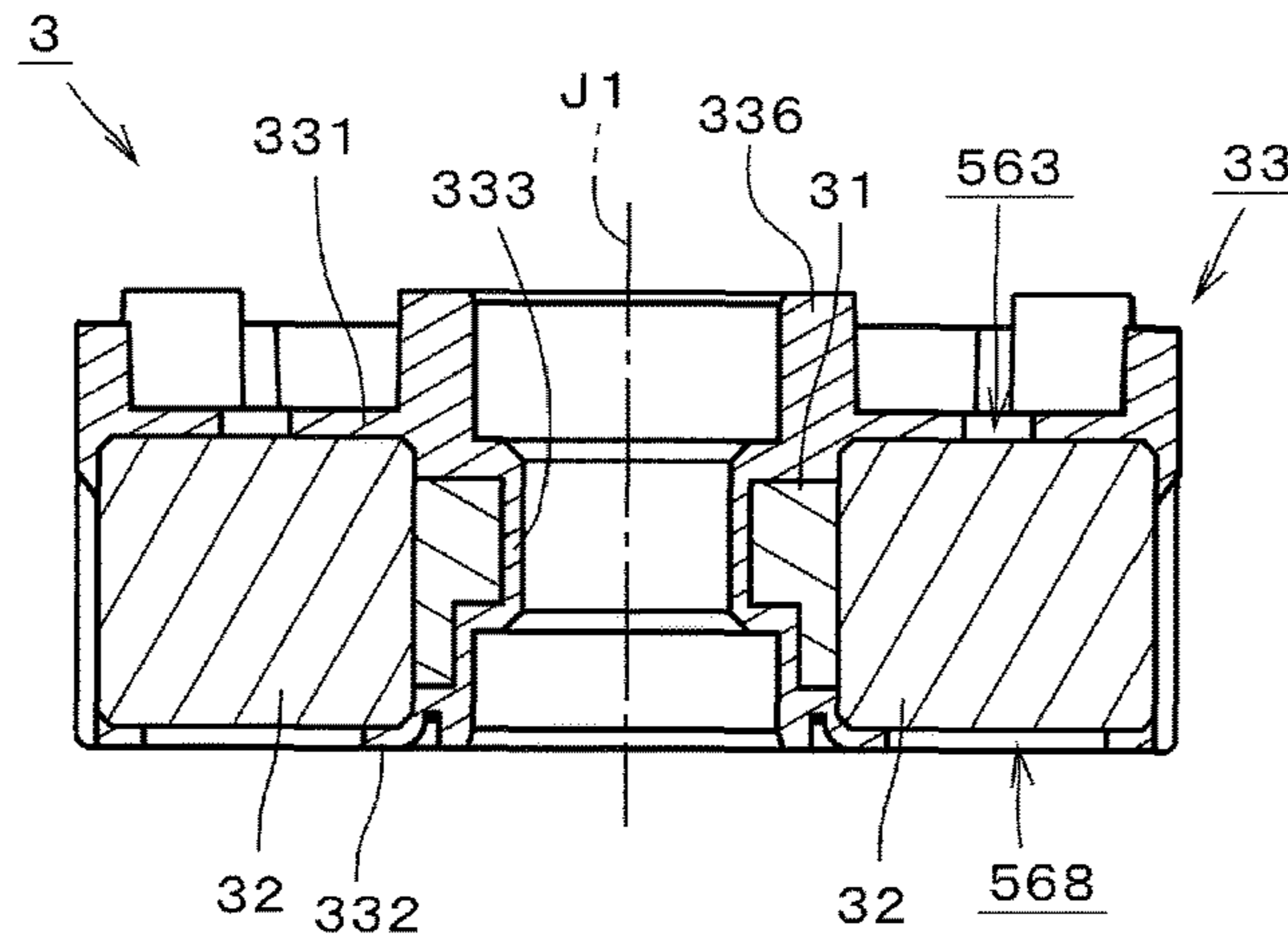

FIG. 7

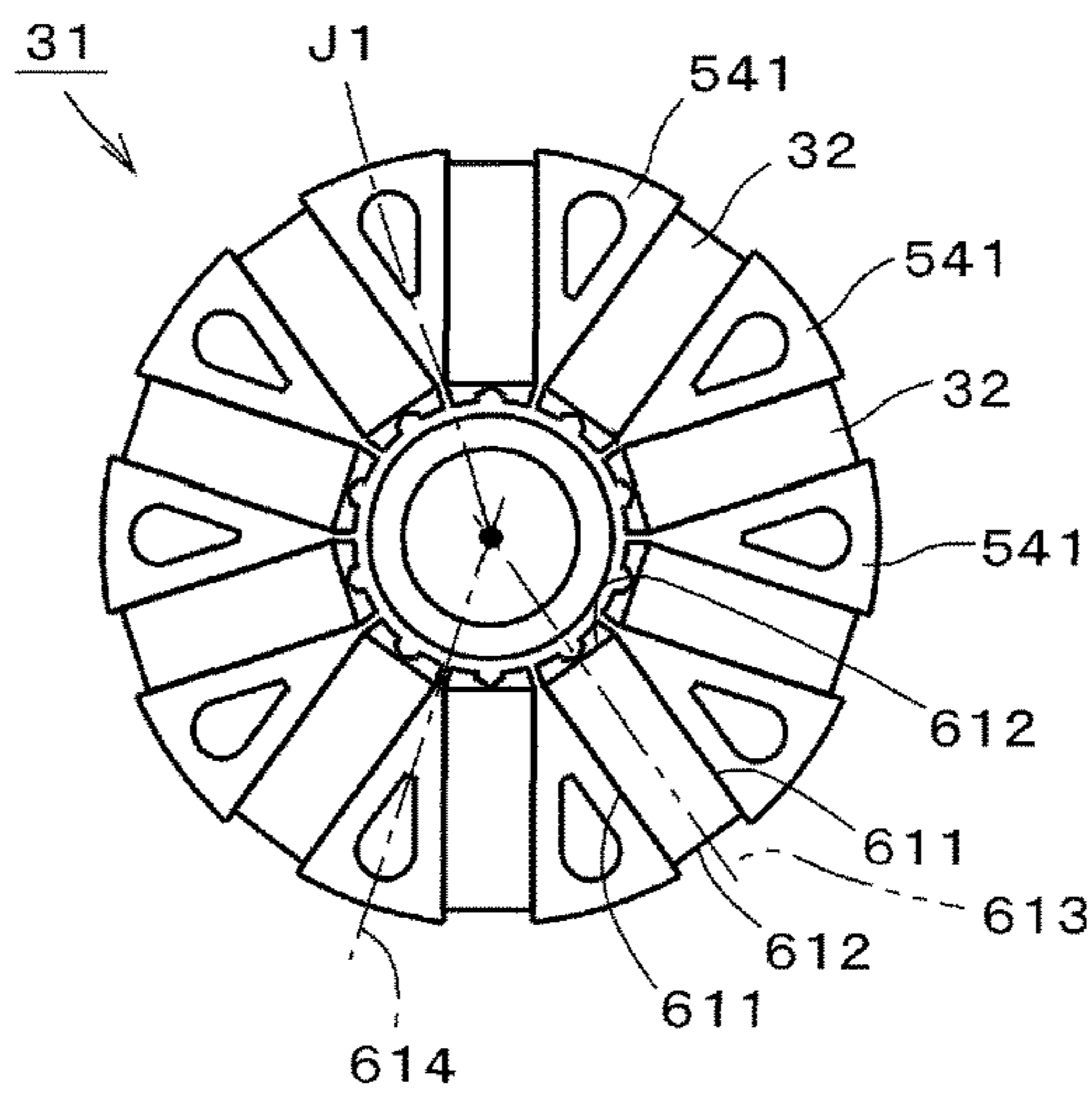

FIG. 8

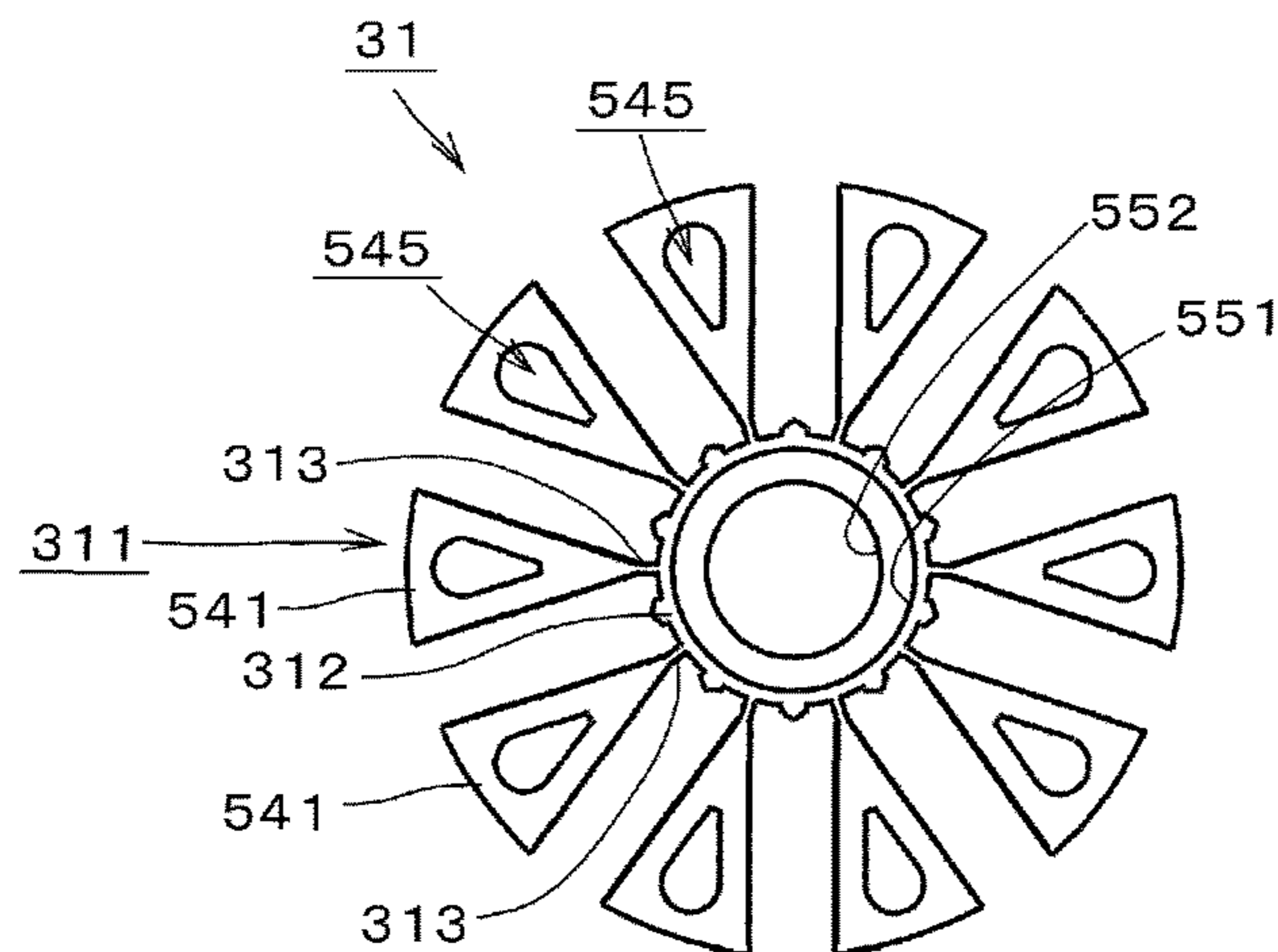

FIG. 9

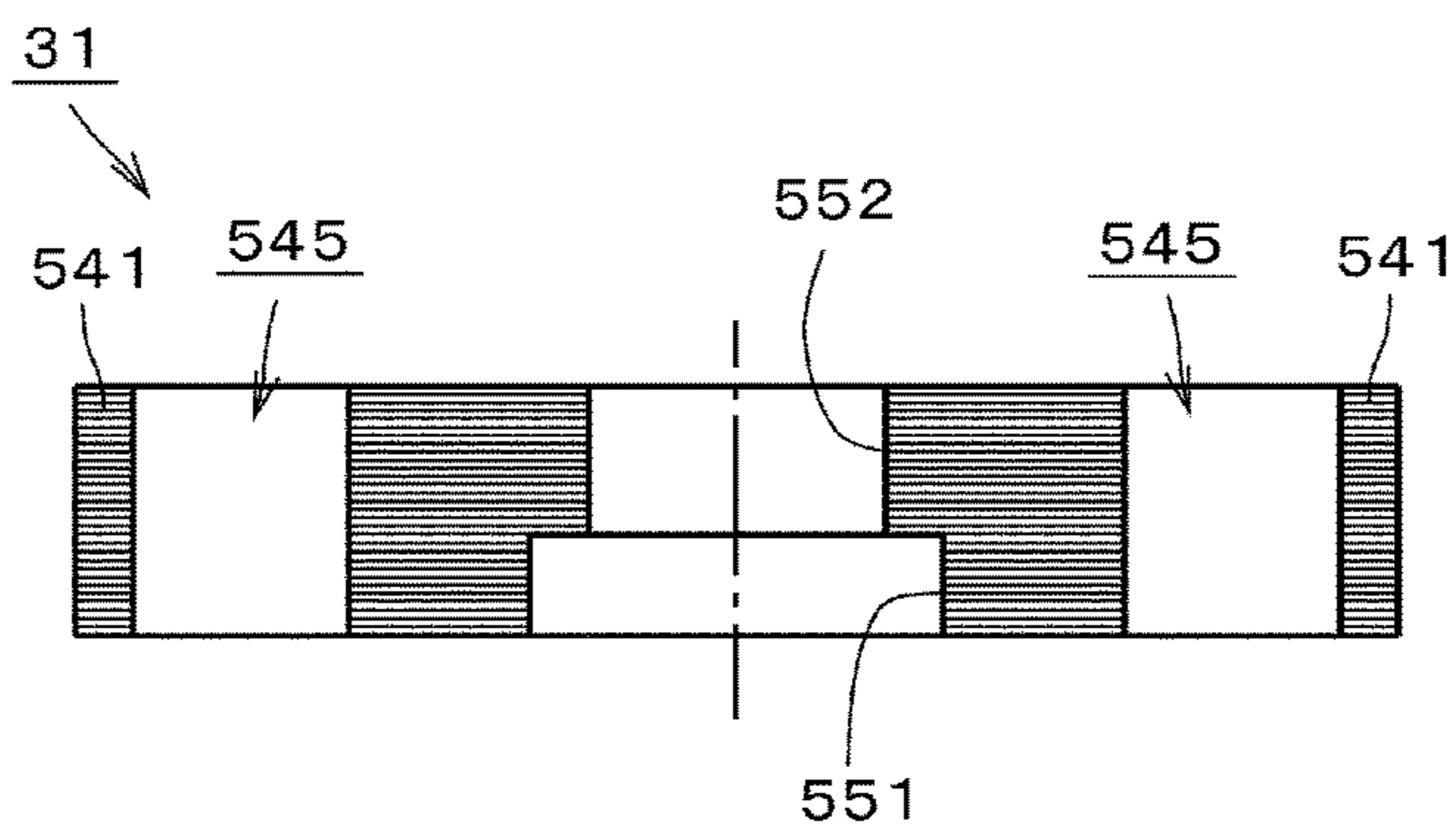

FIG. 10

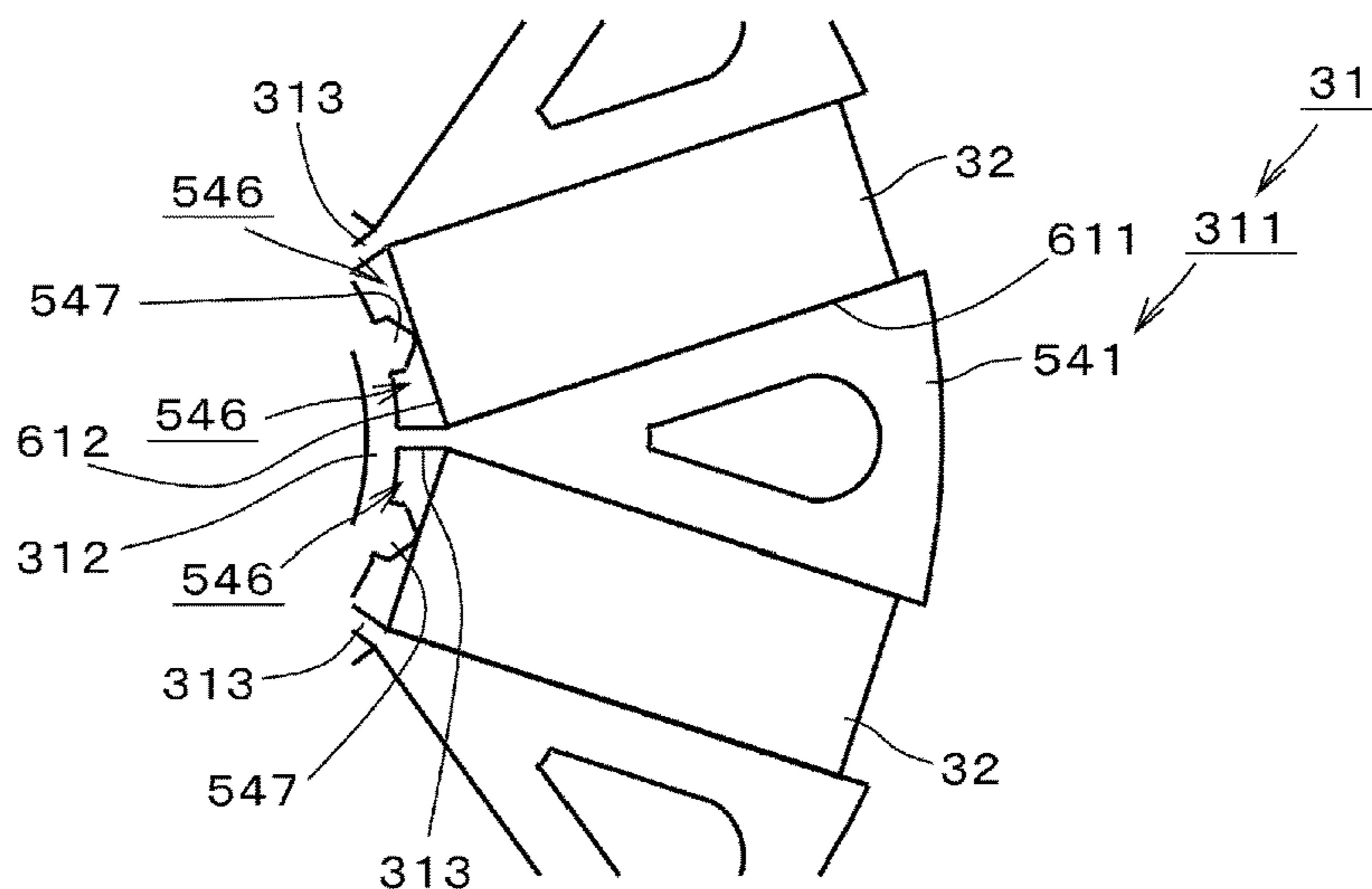
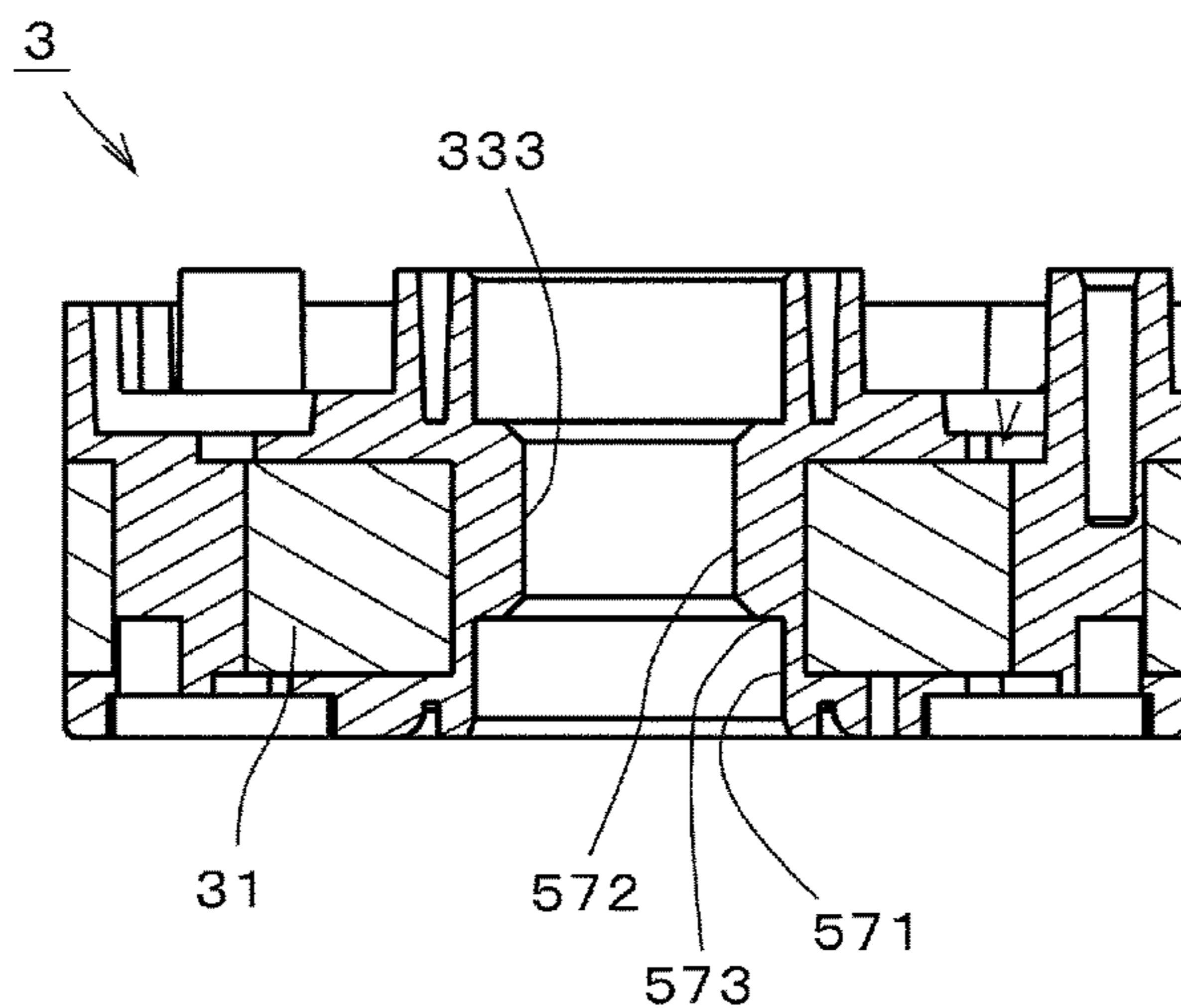

FIG. 11



1

MOTOR

BACKGROUND OF THE INVENTION

1. Field of the Invention

The present disclosure relates to an electric motor.

2. Description of the Related Art

A spoke type IPM (Interior Permanent Magnet) motor has been known in the past, wherein magnets, of which a cross-sectional surface perpendicular to the center axis of the motor is rectangular, are radially disposed within the rotor core. In the spoke type motor, the surface on the longer side is magnetized, and the circumferentially adjacent magnets are arranged so that identical poles face each other. Also in the spoke type motor, in order to maintain the magnets in the rotor core, insert molding can be performed to provide resin around them.

For example, in the rotor core 23 of the motor 1 disclosed in Japanese Patent Application Publication No. 2010-63285, a magnet 25 is received in a slot 24. The entire magnet 25 is covered by a sealing resin 27. Accordingly, the magnet 25 and the rotor core 23 are integrally combined. The inner circumference of the rotor core 23 is not covered by the sealing resin 27.

The rotor 32 of the motor 1 disclosed in the second preferred embodiment of Japanese Patent Application Publication No. 2014-36457 has a laminated core 51, a plurality of magnets 52 and a resin portion 53. The laminated core 51, both axial end surfaces of the plurality of magnets 52 and radially outer surfaces of the magnets 52 are covered with the resin portion 53. The laminated core 51 has an inner core portion 61, a plurality of outer core portions 62 and a plurality of connecting portions 63. The plurality of connecting portions 63 connect the inner core portion 61 and the plurality of outer core portions 62. The top surface of an upper resin portion 531 of the resin portion 53 has a gate hole 91. The gate hole 91 is formed on the upper portion of the outer core portion 62. A lower resin portion 532 has a plurality of second positioning holes 94 disposed in an area which axially overlaps with an outer edge portion of the plurality of outer core portions 62. The resin portion 53 does not exist on the inner circumferential surface of the inner core portion.

SUMMARY OF THE INVENTION

In order to reduce the size of a spoke type IPM motor, it is important to direct a magnetic flux from the magnetic surface of the magnet and deliver it efficiently to the stator. For this reason, the circumferential width of the connecting portion between the outer core portion and the inner core portion is designed as narrowly as possible, so that the magnetic flux can be prevented from flowing into a radially inner side. However, when the width of the connecting portion becomes narrow, the rigidity of the rotor core is lessened, whereby the rotor core can be deformed by the pressure when performing insert molding.

Also, in a conventional rotary unit, the inner circumferential surface of the rotor core and the bottom surface of the inner circumferential portion are not covered with resin as they are the supported portions when performing insert molding. For this reason, deformation of the rotor core can be easily prevented. A bearing or a shaft is retained directly by the inner circumferential surface of the rotor core. In such case, high precision is required for the inner diameter of each magnetic steel plate, and it becomes necessary to frequently polish the mold for puncturing the magnetic

2

plate, and the life span of the mold is shortened. When a bearing is retained by the upper side and the lower side of the rotor core, the size of the motor is axially enlarged.

An object of the present disclosure is to prevent deformation of a connecting portion of the rotor core in a spoke type IPM motor.

The motor according to the first preferred embodiment of the present disclosure comprises a rotary unit which rotates on a vertical center axis, a stationary unit which is disposed around the rotary unit, and a bearing mechanism which rotatably supports the rotary unit relative to the stationary unit. The rotary unit comprises a plurality of magnets arranged in a circumferential direction, a rotor core having a plurality of magnetic steel plates laminated in an axial direction and a resin portion which covers the plurality of magnets and the rotor core. When viewed from above, a radial length of each of the plurality of magnets is longer than the circumferential length thereof. The rotor core comprises a ring-shaped inner core portion disposed on a radially inner side of the plurality of magnets, an outer core portion disposed on a radially outer side of the inner core portion and a plurality of connecting portions which connect the outer core portion and the inner core portion in the radial direction. The outer core portion has a plurality of outer core elements which are connected to the inner core portion via the plurality of connecting portions. The resin portion comprises an upper resin portion which covers at least a part of a top surface of the rotor core and at least a part of the top surface of each magnet and a lower resin portion which covers at least a part of a bottom surface of the rotor core and at least a part of a bottom surface of each magnet. The upper resin portion includes a plurality of gate holes for insert molding of the resin portion. The lower resin portion comprises a plurality of first core support marks which expose a part of the bottom surface of the rotor core in a radially inner side from the plurality of outer core elements, and a plurality of second core support marks expose a part of the bottom surface of the rotor core in the outer core portion.

According to the present disclosure, deformation of the connecting portion between the inner core portion and the outer core portion can be prevented from occurring when performing insert molding.

The above and other elements, features, steps, characteristics and advantages of the present invention will become more apparent from the following detailed description of the preferred embodiments with reference to the attached drawings.

BRIEF DESCRIPTION OF THE DRAWINGS

FIG. 1 is a top view of a motor according to the first preferred embodiment.

FIG. 2 is a vertical sectional view of the motor.

FIG. 3 is a top view of a rotary unit.

FIG. 4 is a bottom view of the rotary unit.

FIG. 5 is a vertical sectional view of the rotary unit.

FIG. 6 is a vertical sectional view of the rotary unit.

FIG. 7 is a bottom view of the rotor core and the magnets.

FIG. 8 is a bottom view of the rotor core.

FIG. 9 is a vertical sectional view of the rotor core.

FIG. 10 is an enlarged top view of the rotor core and the magnets.

FIG. 11 is a vertical sectional view of a rotary unit according to another preferred embodiment.

DETAILED DESCRIPTION OF THE PREFERRED EMBODIMENTS

Herein, in the direction of the center axis J1 of the motor 1, the upper side shown in FIG. 2 is simply referred to as

“upper side”, and the lower side thereof is simply referred to as “lower side”. Also, the upper and lower directions do not necessarily refer to the positional relations or directions when the motor is actually assembled and installed to any equipment. Further, a direction parallel to the center axis J1 is simply referred to as “axial direction”, the radial direction having its center on the center axis J1 is simply referred to as “radial direction”, and the circumferential direction having its center on the center axis J1 is simply referred to as “circumferential direction”.

FIG. 1 is a top view which illustrates a motor 1 according to an exemplary first preferred embodiment of the present disclosure. FIG. 2 is a vertical sectional view of the motor 1. A parallel diagonal line is omitted from the section details. Motor 1 is an inner rotor type brushless motor. The motor 1 includes a stationary unit 2, a rotary unit 3, a bearing mechanism 4 and a circuit board 5. The bearing mechanism 4 rotatably supports the rotary unit 3 with respect to the stationary unit 2, having its center on the center axis J1 of the motor 1. An impeller cup of an impeller can be attached to the rotary unit 3. The motor 1 is used in, for example, a fan for cooling the coolant of a vehicle.

The stationary unit 2 includes a housing 21, a stator 22 and a shaft 23. The stator 22 is disposed around the rotary unit 3. The stationary unit 2 is disposed around the rotary unit 3. The housing 21 includes a base member 211 and a cover 212. The base member 211 has a substantially plate shape which is perpendicular to the center axis J1. The shaft 23 protrudes upwardly, with the lower end fixed to the base member 211. The shaft 23 is disposed to have its center on the center axis J1. The cover 212 has a substantially cylindrical shape, and can be attached on the base member 211. An opening 521 is provided at the center of the cover 212. The opening 521 exposes the rotary unit 3.

The stator 22 includes a stator core 223, an insulator 221 and a coil 222. The stator core 223 includes a plurality of teeth 531 and a core back 532. The core back 532 has a ring shape having its center on the center axis J1. Each of the teeth 531 extends radially inward from the core back 532 to the rotary unit 3. In the stator core 223, electromagnetic steel plates are laminated. The teeth 531 are covered by the insulator 221. The coil 222 is installed to surround the insulator 221.

The circuit board 5 is attached to a bottom surface of the center portion of the base member 211. The circuit board 5 controls the power supply provided to the stationary unit 2. Accordingly, the rotation speed of the rotary unit 3 can be controlled. A lid member 213 is attached to a bottom portion of the base member 211. The lid member 213 covers a bottom surface of the circuit board 5. The base member 211 includes a protrusion 522 which protrudes in a lateral direction. A plurality of wires 523 connected to the circuit board 5 are drawn out from the protrusion 522.

The bearing mechanism 4 has two bearings 41. In this preferred embodiment, the bearing 41 is a ball bearing. The bearing 41 may be of a different structure. The two bearings 41 are provided between the shaft 23 and the rotary unit 3.

The rotary unit 3 includes a rotor core 31, a plurality of magnets 32 and a resin portion 33. The magnet 32 is a permanent magnet. The rotor core 31 is disposed at an inner side of the stator 22 in the radial direction. The outer circumferential surface of the rotor core 31 is adjacent to the inner circumferential surface of the stator 22.

FIG. 3 is a top view of the rotary unit 3. FIG. 4 is a bottom view of the rotary unit 3. FIG. 5 is a vertical sectional view of the rotary unit 3. FIG. 6 is a vertical sectional view of the rotary unit 3, viewed from a different position than FIG. 5.

FIG. 7 is a bottom view of the rotor core 31 and the magnet 32. FIG. 8 is a bottom view of the rotor core 31. FIG. 9 is a vertical sectional view of the rotor core 31. In the rotor core 31, electromagnetic steel plates are axially laminated.

As shown in FIG. 8, the rotor core 31 includes an outer core portion 311, an inner core portion 312 and a plurality of connecting portions 313. The inner core portion 312 has a ring shape. The outer core portion 311 includes a plurality of outer core elements 541. The plurality of outer core elements 541 are arranged in the circumferential direction. Each outer core element 541 has a substantially fan-like shape. The outer core portion 311 is located at a radially outer side of the inner core portion 312. Each connecting portion 313 connects one outer core element 541 and the inner core portion 312 in the radial direction. The connecting portion 313 extends in the radial direction, and connects the circumferential center of the radially inner portion of the outer core element 541 with the outer circumferential surface of the inner core portion 312. The outer core element 541, the inner core portion 312 and the connecting portion 313 form a continuously connected member.

FIG. 9 is a vertical sectional view of the rotor core 31 cut at the circumferential center of the outer core element 541. As shown in FIG. 8 and FIG. 9, the outer core element 541 has a through hole 545 which penetrates in the axial direction. The inner circumferential portion of the rotor core 31, that is, the inner circumferential portion of the inner core portion 312, includes a core large-diameter portion 551 and a core small-diameter portion 552. The core large-diameter portion 551 is disposed at an axially lower side of the core small-diameter portion 552. The inner diameter of the core large-diameter portion 551 is bigger than the inner diameter of the core small-diameter portion 552.

As shown in FIG. 7, magnets 32 are disposed between the outer core elements 541. Each outer core element 541 is a portion which is disposed between any two of the plurality of magnets 32 in the outer core portion 311. The magnets 32 are arranged in the circumferential direction, with identical intervals. The inner core portion 312 is disposed at a radially inner side of the plurality of magnets 32. The rotor core 31 holds the magnets 32. In the cross section perpendicular to the center axis J1, each magnet 32 has a pair of long sides 611 and a pair of short sides 612. That is, in the top view, the radial length of each of the plurality of magnets is longer than the circumferential length thereof. A center-line 613 between the pair of long sides 611 passes through the center axis J1. That is, the center-lines 613 of every magnet 32 intersect on the center axis J1. The motor 1 is a spoke type IPM motor.

The pair of long sides 611 is magnetized into opposite poles from each other. In an adjacent pair of magnets 32, identical poles face each other in the circumferential direction. Accordingly, some of the magnetic field lines are directed outside the rotor core 31 via the outer circumferential surface of the outer core element 541 from the long sides 611 facing each other, entered into the rotor core 31 through the outer circumferential surfaces of the outer core elements 541 that are adjacent at both sides, and guided to the other pole. The outer core element 541 functions as a magnetic pole with respect to the stator 22.

FIG. 10 is an enlarged top view of the rotor core 31 and the magnet 32. As previously described, the outer core portion 311 and the inner core portion 312 are connected by a plurality of connecting portions 313. A flux barrier 546 is provided between the outer core element 541 and the inner core portion 312, and on both sides of the connecting portion 313 in the circumferential direction. The flux barrier 546 is

a space where neither the rotor core **31** nor the magnet **32** exists. In other words, the outer core portion **311** is provided at a radially outer side of the flux barrier **546**. The inner core portion **312** is provided at a radially inner side of the flux barrier **546**. The connecting portion **313** is provided between a pair of adjacent magnets, and is disposed between a pair of flux barriers **546**. In the present preferred embodiment, a part of the resin portion **33** exists within the flux barrier **546**. Accordingly, the resin portion **33** covers around the connecting portion **313** and prevents the inflow of magnetic flux, hence the strength of the connecting portion **313** is improved and deformation can be thereby prevented.

The resin does not necessarily exist in the flux barrier **546**, that is, in the rotor core **31**. It is sufficient if the flux barrier **546** is provided to an area where magnetic resistance is bigger than other portions. For example, in the flux barrier **546**, air or other matter may exist.

The inner core portion **312** includes a plurality of protrusions **547** which protrude outwardly in the radial direction from the outer circumferential surface. Each protrusion **547** is disposed between two connecting portions **313**. The short side **612** of the magnet **32** is in contact with the protrusion **547** in the radial direction. The long side **611** of the magnet **32** is in contact with the outer core element **541** in the circumferential direction. Each flux barrier **546** is defined by an outer circumferential surface of an inner core portion **312**, connecting portions **313**, a short side **612** of a magnet, and a protrusion **547**. The short side **612** is in contact with two flux barriers **546**.

By providing the flux barrier **546**, the magnetic flux can be prevented from heading towards a radially inner side, and thereby the magnetic flux can be efficiently guided towards the outer core element **541** from the magnet **32**. As a result, a large amount of magnetic flux can be derived towards the radially outer side of the outer core element **541**, and thereby the output of the motor **1** can be enhanced without changing its size. In other words, it is possible to prevent reduction of the output and achieve miniaturization of the motor **1**.

In order to prevent the inflow of magnetic flux into the inner core portion **312**, it is preferable that the connecting portion **313** is thin. With such feature, the connecting portion **313** can easily be magnetically saturated, and block out the magnetic flux. Preferably, the radial length of the connecting portion **313** is longer than the circumferential width thereof.

FIG. **5** is a vertical sectional view of the rotary unit **3** which includes the center axis **J1**, and which is defined by a surface that passes through the circumferential center of the outer core element **541**. FIG. **6** is a vertical section view of the rotary unit **3** which includes the center axis **J1**, and which is defined by a surface that passes through the circumferential center of the magnet **32**. The plurality of magnets **32** and the rotor core **31** are covered by the resin portion **33**. The resin portion **33** includes an upper resin portion **331**, a lower resin portion **332** and an inner circumferential resin portion **333**.

The upper resin portion **331** covers at least a part of the top surface of the rotor core **31** and at least a part of the top surface of each magnet **32**. The lower resin portion **332** covers at least a part of the bottom surface of the rotor core **31** and at least a part of the bottom surface of each magnet **32**. With such feature, the rotor core **31** and the magnet **32** become integrated by the resin portion **33** in the axial direction. Preferably, the resin portion **33** covers at least a part of the radially outer side surface of the magnet **32**, and holds the magnet **32** in the radial direction. Of course, the retainment of the magnet **32** with respect to the rotor core **31** can also be accomplished with different structures.

The inner circumferential resin portion **333** covers the inner circumferential surface of the rotor core **31**, and has a ring shape. It is not necessarily required to strictly define the boundary among upper resin portion **331**, the lower resin portion **332** and the inner circumferential resin portion **333**. The upper resin portion **331** and the lower resin portion **332** are connected with the inner circumferential resin portion **333**, and form a continuously connected member. The upper resin portion **331**, the lower resin portion **332** and the inner circumferential resin portion **333** may not be connected.

As shown in FIG. **3**, FIG. **5** and FIG. **6**, the upper resin portion **331** includes a plurality of gate holes **561**, a plurality of upper core support marks **562**, a plurality of upper magnet support marks **563** and an impeller attachment portion **564**. The position of the gate hole **561** corresponds to the position of the gate from insert molding. The circumferential position of the gate holes **561** is identical to the circumferential position of the outer core elements **541**. The number of gate holes **561** is identical to the number of outer core elements **541**. The gate hole **561** is formed on a radially inner side area of the outer core element **541**.

The upper core support mark **562** is a mark of a pin which supports the outer core element **541** from the upper side during insert molding. The circumferential position of the upper core support marks **562** is identical to the circumferential position of the outer core elements **541**. The number of upper core support marks **562** is identical to the number of outer core elements **541**. The upper core support mark **562** overlaps with the radially inner side area of the through hole **545** of the outer core element **541**. The inside of the through hole **545** may be filled with resin or not filled with resin. In the upper core support mark **562**, a part of the top surface of the rotor core **31** is exposed.

The upper magnet support mark **563** is a mark of a pin which supports the magnet **32** from the upper side while performing insert molding. The circumferential position of the upper magnet support marks **563** is identical to the circumferential position of the magnets **32**. The number of upper magnet support marks **563** is identical to the number of magnets **32**. The radial position of the upper magnet support mark **563** is a substantial center of the magnet **32** in the radial direction. In the upper magnet support mark **563**, a part of the top surface of the magnet **32** is exposed.

The impeller attachment portion **564** is a area where an impeller cup is attached to the rotary unit **3**. The circumferential position of the impeller attachment portions **564** is identical to the circumferential position of the outer core elements **541**. In the present preferred embodiment, the number of impeller attachment portions **564** is about half the number of outer core elements **541**. The circumferential position of the plurality of impeller attachment portions **564** is identical to the every other circumferential position of the outer core elements **541**. The impeller attachment portion **564** overlaps with the radially outer side area of the outer core element **541**.

As shown in FIG. **4**, FIG. **5** and FIG. **6**, the lower resin portion **332** includes a plurality of first lower core support marks **566**, a plurality of second lower core support marks **567** and a plurality of lower magnet support marks **568**. The first lower core support mark **566** is a mark of a pin which supports at least one direction of the connecting portion **313** and the inner core portion **312** from the lower side during insert molding. The circumferential position of the first lower core support marks **566** is identical to the circumferential position of the outer core elements **541**, that is, that of the connecting portion **313**. The number of first lower core support marks **566** is about half the number of outer core

elements **541**. The circumferential position of the plurality of first lower core support marks **566** is identical to the every other circumferential position of the outer core elements **541**.

In the first lower core support mark **566**, a part of the bottom surface of the rotor core **31** is exposed. The pin of the mold corresponding to the first lower core support mark **566** may support only the inner core portion **312**, or only the connecting portion **313**. That is, the first lower core support mark **566** is disposed at a radially inner side than the outer core element **541**. In the present preferred embodiment, the pin supports at least a part of the inner core portion **312** and at least a part of the connecting portion **313**. Accordingly, from the first lower core support mark **566**, a part of the inner core portion **312** and a part of the connecting portion **313** are exposed.

Including the flux barrier **546**, resin exists around the connecting portion **313**. However, it does not exist in the first lower core support mark **566**. For this reason, whether or not the connecting portion **313** is deformed during insert molding can be easily visually observed through the first lower core support mark **566**. Accordingly, before electric current is actually provided to the motor **1**, any problem caused by the deformation of the rotor core **31** can be found.

Except for that the second lower core support mark **567** is provided at the lower resin portion **332**, its number, the circumferential and radial positions are identical to those of the upper core support mark **562**. In each second lower core support mark **567**, a part of the bottom surface of the rotor core **31** in the outer core portion **311** is exposed.

The lower magnet support mark **568** is a mark of a pin which supports the magnet **32** from the lower side while insert molding. The circumferential position of the lower magnet support marks **568** is identical to the circumferential position of the magnets **32**. The number of lower magnet support marks **568** is identical to the number of magnets **32**. The lower magnet support mark **568** has a rectangular shape that is smaller than the magnet **32**. In the lower magnet support mark **568**, a part of the bottom surface of the magnet **32** is exposed.

By providing the first lower core support mark **566** at a more radially inner side than the outer core element **541**, that is, by supporting the rotor core **31** at a more radially inner side than the outer core element **541** within the mold, the deformation of a rigid and small connecting portion **313** can be prevented, even when the resin is injected into the mold downwardly from an upper side. As a result, irregularity in the quality of the motor **1** can be reduced. The “prevention of deformation” of the connecting portion **313** in the present preferred embodiment includes “reduction of deformation”. The support for the rotor **31** in the first lower core support mark **566** is suitable when the radius of the rotor core **31** is bigger than the axial thickness of the rotor **31** and when the connecting portion **313** is easy to deform, as shown in FIG. **9**.

In this preferred embodiment, each of the plurality of first lower core support marks **566** overlaps with at least a part of any one of the connecting portions **313**. In this case, comparing with the case in which the first lower core support mark **566** overlaps with the inner core portion **312**, the first lower core support mark **566** is positioned at a radially outer side. As a result, the profile accuracy of the inner circumferential surface of the lower resin portion **332** can be enhanced. The enhancement of the profile accuracy of the inner circumferential surface of the lower resin portion **332** is preferable when the bearing **41** is retained at the inner circumferential surface, as described in detail below.

The plurality of gate holes **561** are provided in the radial direction, and disposed between the plurality of first lower core support mark **566** and the plurality of second lower core support mark **567**. Accordingly, when performing insert molding, it is possible to stably support the rotor core **31**, which receives pressure from the flowing resin, by the first lower core support mark **566** and the second lower core support mark **567**.

As described above, the circumferential center position of each gate hole **561** and each first lower core support mark **566** is identical to the circumferential center position of the outer core element **541**. In other words, as illustrated in FIG. **7**, the circumferential center position of each gate hole **561** and each first lower core support mark **566** overlaps in the axial direction with the center-line **614** which heads towards the radial direction via the circumferential center position of any one of the connecting portions **313**. Accordingly, also when performing insert molding, the rotor core **31** can be stably supported. The support of the rotor core **31** can also be stabilized by disposing the second lower core support mark **567** on the center-line **614**. However, if the plurality of second lower core support marks **567** are correspondingly provided to a single outer core element **541**, it is unnecessary for the second lower core support mark **567** to be disposed on the center-line **614**.

As shown in FIG. **5**, the resin portion **33** has a cylindrical shape having its center on the center axis **J1**, and includes another cylindrically-shaped resin portion **334** which protrudes upwardly, away from the rotor core **31**. The resin portion **33** includes another cylindrically-shaped resin portion **335** which covers the outer circumference of the cylindrically-shaped resin portion **334**. Hereinafter, the cylindrically-shaped resin portion **334** is referred to as “inner cylindrical resin portion”, and the cylindrically-shaped resin portion **335** as “outer cylindrical resin portion”. As shown in FIG. **3** and FIG. **6**, the resin portion **33** further includes a plurality of rib portions **336** which connect the inner cylindrical resin portion **334** and the outer cylindrical resin portion **335** in the radial direction.

As shown in FIG. **2**, the inner cylindrical resin portion **334** functions as a bearing support portion for holding the upper bearing **41** in the inner circumferential surface. The bearing **41** is accurately retained in the inner cylindrical resin portion **334** at a press-fit state. By providing the inner cylindrical resin portion **334**, the bearing **41** can be retained with a higher positional accuracy by the resin, even if the rotor core **31** is thin. By providing the outer cylindrical resin portion **335** and the rib portion **336**, the rigidity of the inner circumferential surface of the inner cylindrical resin portion **334** can be enhanced, and the retainment of the bearing **41** of the upper side can also be improved as well. Especially, with the space in between the inner cylindrical resin portion **334** and the outer cylindrical resin portion **335** where the rib portion **336** is provided, a decrease in the inner diameter accuracy of the inner cylindrical resin portion **334** caused by the contraction of the resin can be prevented.

The impeller attachment portion **564** is provided around the inner cylindrical resin portion **334** and the outer cylindrical resin portion **335**. At the center of the impeller cup, a hole portion or a concave portion is provided for inserting the cylindrical resin portions. Accordingly, the height of the fan can be suppressed.

As described with reference to FIG. **9**, the inner circumferential portion of the rotor core **31** includes a core large-diameter portion **551** and a core small-diameter portion **552**. As shown in FIG. **5**, the inner circumferential resin portion **333** includes a resin large-diameter portion **571**, a resin

small-diameter portion and a resin stepped portion 573. The resin large-diameter portion 571 covers the inner circumferential surface of the core large-diameter portion 551. The resin small-diameter portion 572 covers the inner circumferential surface of the core small-diameter portion 552. The resin large-diameter portion 571 and the resin small-diameter portion 572 respectively have a substantially cylindrical shape, having the center on the center axis J1. The resin stepped portion 573 has a ring shape which expands out perpendicularly to the center axis J1, and connects the upper end of the resin large-diameter portion 571 and the lower end of the small-diameter portion 572 in the radial direction.

The inner cylindrical resin portion 334 is disposed on the upper side of the resin small-diameter portion 572. The inner diameter of the resin small-diameter portion 572 is smaller than the inner diameter of the inner cylindrical resin portion 334, and a stepped portion is provided between the resin small-diameter portion 572 and the inner cylindrical resin portion 334. As shown in FIG. 2, the lower bearing 41 is retained at the inner circumferential surface of the resin large-diameter portion 571. The upper end of the bearing 41 is in contact with the bottom surface of the resin stepped portion 573. Accordingly, the axial position of the bearing 41 can be easily determined. The bearing 41 is accurately retained in the resin large-diameter portion 571 in a direction perpendicular to the center axis J1 at a press-fit state. Since the inner circumference of the rotor core 31 is covered by resin, burrs of the laminated steel plates are prevented from falling apart. As a result, increase of noise or shortening of life span caused by, for example, the fallen burr entering the bearing 41, can be prevented.

Also by disposing the upper end of the lower bearing 41 in an upper position from the bottom surface of the rotor core 31, the bearing 41 is retained at the inner side of the rotor core 31, and the height of the motor 1 can be suppressed lower and weight lightening of the motor can be realized. In case the bearing 41 is directly held at the rotor core 31, in order to maintain a highly precise inner diameter of the rotor core 31, it becomes necessary to increase the number of grinding the mold which drills holes in the steel plate. By retaining the bearing at the resin portion 33, in the direction perpendicular to the center axis J1, the high precision of resin molding can be acquired, the bearing 41 can be retained with high precision, and since the molding temperature of the resin is low, less abrasion is occurred on the mold, and therefore grinding of the mold becomes unnecessary in the first place, and it is thereby possible to extend the life of the mold.

As shown in FIG. 2, the circuit board 5 is disposed perpendicularly to the center axis J1. The lower bearing 41 is retained at the inner circumferential resin portion 333, and also, the lower end of the shaft 23, that is, the end portion of the lower bearing 41 side of the shaft 23 is supported by the stationary unit 2. Accordingly, it becomes possible to suppress the height of the motor 1, and dispose the lower end of the shaft 23 and the circuit board 5 in the axial direction. As a result, it becomes unnecessary to provide a through hole on the circuit board 5 for the penetration of the shaft 23, and the circuit board 5 can be made smaller in the radial direction. Also, miniaturization, weight lightening and low manufacturing cost of the motor 1 can be acquired.

As shown in FIG. 1 and FIG. 2, the upward portion of the stator 22 is covered by the cover 212. The cover 212 includes a plurality of openings 214 arranged in the circumferential direction above the stator 22. This opening 214 may be a through hole, and may also be a notch cut from a radially inner side towards the outer side. The heat generated

at the stator 22 can be released to the outside by the air flow or radiated through the opening 214. Meanwhile, the cover 212 blocks the radiation of electromagnetic waves generated from the coil end of the stator 22, and also has a function of preventing EMI (electro-magnetic interference).

For the function of preventing EMI, the opening 214 is preferably small. However, when the opening 214 is made small, heat radiation is deteriorated. Thus, in motor 1, the circumferential center of the opening 214 is disposed between a coil 222 and another coil 222, so that EMI can be reduced and heat radiation can be secured. Such reduction of EMI is especially suitable for a motor for vehicles. Also, by disposing the opening 214 between coils 222, air flow generated by the rotation of the rotary unit 3 can be easily occurred at the position of the opening 214, and heat radiation can be obtained even with a small opening 214.

In the top view, it is preferable for the coil 222 to be almost completely hidden by the cover 212, and it is also preferable to form a larger opening 214. For this reason, it is preferable for the opening 214 to have a circumferential width gradually increasing towards a radially outward side. In an example shown in FIG. 1, in an area between an opening 214 and another opening 214 adjacent to each other, two sides 215 in contact with both of the openings 214 are parallel with each other and head towards substantially in the radial direction. Accordingly, it is possible to easily prevent foreign matter from becoming in contact with the coil 222.

FIG. 11 illustrates another example of the rotary unit 3, and corresponds to FIG. 5. The diameter of the inner circumferential portion of the rotor core 31 is constant. Meanwhile, the inner circumferential resin portion 333 comprises, as shown in FIG. 5, a resin large-diameter portion 571, a resin small-diameter portion 572 and a resin stepped portion 573. The resin large-diameter portion 571 covers the lower portion of the inner circumferential surface of the rotor core 31, and the resin small-diameter portion 572 covers the middle and upper portions of the inner circumferential surface of the rotor core 31. The inner diameter of the resin small-diameter portion 572 is smaller than the inner diameter of the resin large-diameter portion 571. The resin stepped portion 573 connects the resin large-diameter portion 571 and the resin small-diameter portion 572. The lower bearing 41 is retained at the resin large-diameter portion 571. The upper end of the bearing 41 is in contact with the bottom surface of the resin stepped portion 573.

In the axial direction, since the inner diameter of the rotor core 31 is constant, the manufacturing costs of the rotor core 31 can be reduced. Meanwhile, by installing the resin large-diameter portion 571, the resin small-diameter portion 572 and the resin stepped portion 573, the position of the lower bearing 41 can be accurately arranged.

A variety of modifications can be made to the motor 1. In the housing 21, the base member 211 and the cover 212 can be a single member. On the contrary, the housing 21 can be a combination of three or more elements. In the rotor core 31, it is unnecessary for the width of the connecting portion 313 to be constant. The connecting portion 313 is disposed at a more radially inner side than the magnet 32, and has a width which is equal to or smaller than the minimum circumferential width of the outer core element 541. The length of the connecting portion 313 can be shorter. In the top view, the connecting portion 313 is a constricted portion between the outer core element 541 and the inner core portion 312. It is unnecessary for the magnet 32 have a rectangular shape when seen in the top view.

11

The number of poles of the rotary unit **3** and the stationary unit **2** can be variously modified. A variety of methods can be employed for fixing the magnet **32** to the rotor **31**. For example, an adhesive can be jointly used, and a part of the laminated steel plate can fix the position of the magnet **32**.

The gate hole **561** and the first lower core support mark **566** can be partially overlapped. In such case, the connecting portion **313** receives a strong force from the resin when performing insert molding. However, deformation of the connecting portion **313** can be prevented from occurring at the first lower core support mark **566**.

The shape of each support mark formed at the resin portion **33** is not limited to a hole shape. For example, it can be a notch-like shape which is provided on the edge, such as the outer circumference or the inner circumference of the rotor core **31**. It is unnecessary for the inner circumferential resin portion **333** to cover the entire inner circumferential surface of the rotor core **31**. It is sufficient if at least a part of the inner circumferential surface is covered. The resin portion **333** can be connected to only one of the upper resin portion **331** and the lower resin portion **332**.

The upper bearing **41** and the lower bearing **41** can be alternately exchanged. That is, the inner cylindrical resin portion **334** may be connected to the lower resin portion **332**, and thereby the resin large-diameter portion **571** can be connected to the upper resin portion **331**. This structure is substantially identical to the structure illustrated in FIG. **2**, the only difference is that the upper bearing **41** and the lower bearing **41** are not alternately exchanged, and the upper resin portion **331** and the lower resin portion **332** are alternately exchanged. As long as the gate hole **561** and the first lower core support mark **566** exist on an opposite side from the rotor core **31**, the position or the shape of a support mark can be variously modified.

In the motor **1**, the shaft **23** is fixed to the stationary unit **2**. However, a rotating shaft structure can also be employed. In this case, the shaft would be fixed to, for example, the inner circumferential resin portion. Also in this case, as described above, since the precision of the inner diameter of the inner circumferential resin portion can be easily enhanced, the manufacturing costs of the rotary unit **3** can be reduced. Regardless of whether the shaft is provided in a fixed feature or in a rotating feature, by providing the inner circumferential resin portion, a bearing mechanism (in case the bearing mechanism includes a plurality of bearings, at least a part of the bearing mechanism) or the shaft can be accurately retained at the inner circumferential resin portion.

The structure of retaining the bearing or the shaft at the inner circumferential resin portion may be separated from the technique of installing the support mark in a more radially inner side than the outer core element **541**, and employed in a variety of types of motors. Likewise, the technique of installing an opening **214** for ventilation to the cover **212** may be separated from installing the support mark in a more radially inner side than the outer core element **541**, and employed in a variety of types of motors. Of course, the structure of retaining the bearing or the shaft at the inner circumferential resin portion and the technique of installing the opening **214** for ventilation to the cover **212** may be separated from each other, and employed in a variety of types of motors.

The respective elements shown in the preferred embodiments and the modification may be appropriately combined with each other as long as contradiction does not occur.

The motor according to the present disclosure can be used as a driving source for a variety of purposes.

12

While preferred embodiments of the present invention have been described above, it is to be understood that variations and modifications will be apparent to those skilled in the art without departing from the scope and spirit of the present invention. The scope of the present invention, therefore, is to be determined solely by the following claims.

What is claimed is:

1. A motor, comprising:

a rotary unit which rotates on a vertical center axis;
a stationary unit which is disposed around the rotary unit;
a bearing mechanism which rotatably supports the rotary unit relative to the stationary unit; and

a shaft which is rotatably supported relatively with respect to the bearing mechanism, wherein the rotary unit comprises:

a plurality of magnets arranged in a circumferential direction;

a rotor core provided with a plurality of magnetic steel plates laminated in an axial direction; and

a resin portion covering the plurality of magnets and the rotor core,

when seen from above, a radial length of each of the plurality of magnets is longer than its circumferential length,

the rotor core comprises:

a ring-shaped inner core portion disposed on a radially inner side of the plurality magnets;

an outer core portion disposed on a radially outer side of the inner core portion; and

a plurality of connecting portions connecting the outer core portion and the inner core portion in a radial direction,

the outer core portion having a plurality of outer core elements which are connected to the inner core portion through the plurality of connecting portions,

the resin portion comprises:

an upper resin portion covering at least a part of the top surface of a rotor core and at least a part of a top surface of each magnet; and

a lower resin portion covering at least a part of a bottom surface of the rotor core and at least a part of a bottom surface of each magnet,

the resin portion further comprising a ring-shaped inner circumferential resin portion which covers the inner circumferential surface of the rotor core,

the upper resin portion and the lower resin portion being continuously connected with the inner circumferential resin portion,

the bearing mechanism or the shaft being retained by the inner circumferential resin portion,

the stationary unit is provided with a shaft, the bearing mechanism is provided with an upper bearing and a lower bearing,

the resin portion further comprises a ring-shaped inner circumferential resin portion which covers at least a portion of the inner circumferential surface of the rotor core,

the inner circumferential resin portion is continuously connected to at least one of the upper resin portion and the lower resin portion,

one of the upper bearing and the lower bearing is retained in the inner circumferential resin portion,

the inner circumferential portion of the rotor core includes a core large-diameter portion and a core small-diameter portion,

the inner circumferential resin portion comprises:

13

a resin large-diameter portion which covers the core large-diameter portion;
 a resin small-diameter portion which covers the core small-diameter portion; and
 a resin stepped portion between the resin large-diameter portion and the resin small-diameter portion, and the one of the upper bearing and the lower bearing is retained in the resin large-diameter portion, and is in contact with the resin stepped portion.

2. The motor according to claim 1, wherein the diameter of the inner circumferential portion of the rotor core is constant, the inner circumferential resin portion comprising:
 a resin large-diameter portion which covers the inner circumferential portion of the rotor core;
 a resin small-diameter portion which covers the inner circumferential portion of the rotor core, and has an inner diameter smaller than the inner diameter of the resin large-diameter portion; and
 a resin stepped portion between the resin large-diameter portion and the resin small-diameter portion, and wherein the one of the bearings is retained in the resin large-diameter portion, and is in contact with the resin stepped portion.

3. The motor according to claim 2, wherein the resin portion has a cylindrical shape having its center on the center axis, and further comprises a cylindrical resin portion which protrudes away from the rotor core, and one of the upper bearing and the lower bearing is retained in the cylindrical resin portion.

4. The motor according to claim 3, wherein the resin portion is provided with an attachment portion around the cylindrical resin portion for attaching an impeller cup.

5. The motor according to claim 4, further comprising a circuit board disposed perpendicularly to the center axis, wherein an end portion of the one bearing of the shaft is supported by the stationary unit, and thereby the circuit board axially faces the end portion of the shaft.

6. The motor according to claim 3, further comprising a circuit board disposed perpendicularly to the center axis, wherein an end portion of the one bearing of the shaft is supported by the stationary unit, and thereby the circuit board axially faces the end portion of the shaft.

7. The motor according to claim 2, further comprising a circuit board disposed perpendicularly to the center axis, wherein an end portion of the one bearing of the shaft is supported by the stationary unit, and thereby the circuit board axially faces the end portion of the shaft.

8. The motor according to claim 1, wherein the resin portion has a cylindrical shape having its center on the center axis, and further comprises a cylindrical resin portion which protrudes away from the rotor core, and one of the upper bearing and the lower bearing is retained in the cylindrical resin portion.

9. The motor according to claim 8, wherein the resin portion further comprises another cylindrical resin portion which covers the outer circumference of the cylindrical resin portion, and

14

the cylindrical resin portion and the other cylindrical resin portion are connected by a plurality of rib portions in the radial direction.

10. The motor according to claim 9, wherein the resin portion is provided with an attachment portion around the cylindrical resin portion for attaching an impeller cup.

11. The motor according to claim 10, further comprising a circuit board disposed perpendicularly to the center axis, wherein an end portion of the one bearing of the shaft is supported by the stationary unit, and thereby the circuit board axially faces the end portion of the shaft.

12. The motor according to claim 9, further comprising a circuit board disposed perpendicularly to the center axis, wherein an end portion of the one bearing of the shaft is supported by the stationary unit, and thereby the circuit board axially faces the end portion of the shaft.

13. The motor according to claim 8, wherein the resin portion is provided with an attachment portion around the cylindrical resin portion for attaching an impeller cup.

14. The motor according to claim 13, further comprising a circuit board disposed perpendicularly to the center axis, wherein an end portion of the one bearing of the shaft is supported by the stationary unit, and thereby the circuit board axially faces the end portion of the shaft.

15. The motor according to claim 8, further comprising a circuit board disposed perpendicularly to the center axis, wherein an end portion of the one bearing of the shaft is supported by the stationary unit, and thereby the circuit board axially faces the end portion of the shaft.

16. The motor according to claim 1, wherein the resin portion has a cylindrical shape having its center on the center axis, and further comprises a cylindrical resin portion which protrudes away from the rotor core, and one of the upper bearing and the lower bearing is retained in the cylindrical resin portion.

17. The motor according to claim 16, wherein the resin portion is provided with an attachment portion around the cylindrical resin portion for attaching an impeller cup.

18. The motor according to claim 17, further comprising a circuit board disposed perpendicularly to the center axis, wherein an end portion of the one bearing of the shaft is supported by the stationary unit, and thereby the circuit board axially faces the end portion of the shaft.

19. The motor according to claim 16, further comprising a circuit board disposed perpendicularly to the center axis, wherein an end portion of the one bearing of the shaft is supported by the stationary unit, and thereby the circuit board axially faces the end portion of the shaft.

20. The motor according to claim 1, further comprising a circuit board disposed perpendicularly to the center axis, wherein an end portion of the one bearing of the shaft is supported by the stationary unit, and thereby the circuit board axially faces the end portion of the shaft.

21. The motor according to claim 1, further comprising a circuit board disposed perpendicularly to the center axis, wherein an end portion of the one bearing of the shaft is supported by the stationary unit, and thereby the circuit board axially faces the end portion of the shaft.