

(12) **United States Patent**
Sayyar-Rodsari et al.

(10) **Patent No.: US 10,067,485 B2**
(45) **Date of Patent: Sep. 4, 2018**

(54) **INTEGRATED OPTIMIZATION AND CONTROL FOR PRODUCTION PLANTS**

(56) **References Cited**

(71) Applicant: **ROCKWELL AUTOMATION TECHNOLOGIES, INC.**, Mayfield Heights, OH (US)

(72) Inventors: **Bijan Sayyar-Rodsari**, Austin, TX (US); **Carl Anthony Schweiger**, Round Rock, TX (US)

(73) Assignee: **Rockwell Automation Technologies, Inc.**, Mayfield Heights, OH (US)

(*) Notice: Subject to any disclaimer, the term of this patent is extended or adjusted under 35 U.S.C. 154(b) by 416 days.

(21) Appl. No.: **14/860,367**

(22) Filed: **Sep. 21, 2015**

(65) **Prior Publication Data**
US 2016/0011572 A1 Jan. 14, 2016

Related U.S. Application Data

(63) Continuation of application No. 12/609,785, filed on Oct. 30, 2009, now Pat. No. 9,141,098.

(51) **Int. Cl.**
G05B 13/04 (2006.01)

(52) **U.S. Cl.**
CPC **G05B 13/04** (2013.01)

(58) **Field of Classification Search**
CPC **G05B 13/04**
See application file for complete search history.

U.S. PATENT DOCUMENTS

5,486,995 A 1/1996 Krist et al.
5,666,297 A 9/1997 Britt et al.
5,781,432 A * 7/1998 Keeler G05B 13/0285
700/44

6,038,540 A 3/2000 Krist et al.
(Continued)

OTHER PUBLICATIONS

Tosukhowong, Thidarat, "Dynamic Real-Time Optimization and Control of an Integrated Plant", Thesis, Georgia Tech, Dec. 2006.
(Continued)

Primary Examiner — Nathan L Laughlin
(74) *Attorney, Agent, or Firm* — Fletcher Yoder, P.C.

(57) **ABSTRACT**

The present invention provides novel techniques for optimizing and controlling production plants using parametric multifaceted models. In particular, the parametric multifaceted models may be configured to convert a first set of parameters (e.g., control parameters) relating to a production plant into a second set of parameters (e.g., optimization parameters) relating to the production plant. In general, the first set of parameters will be different than the second set of parameters. For example, the first set of parameters may be indicative of low-level, real-time control parameters and the second set of parameters may be indicative of high-level, economic parameters. Utilizing appropriate parameterization may allow the parametric multifaceted models to deliver an appropriate level of detail of the production plant within a reasonable amount of time. In particular, the parametric multifaceted models may convert the first set of parameters into the second set of parameters in a time horizon allowing for control of the process plant by a control system based on the second set of parameters.

17 Claims, 6 Drawing Sheets

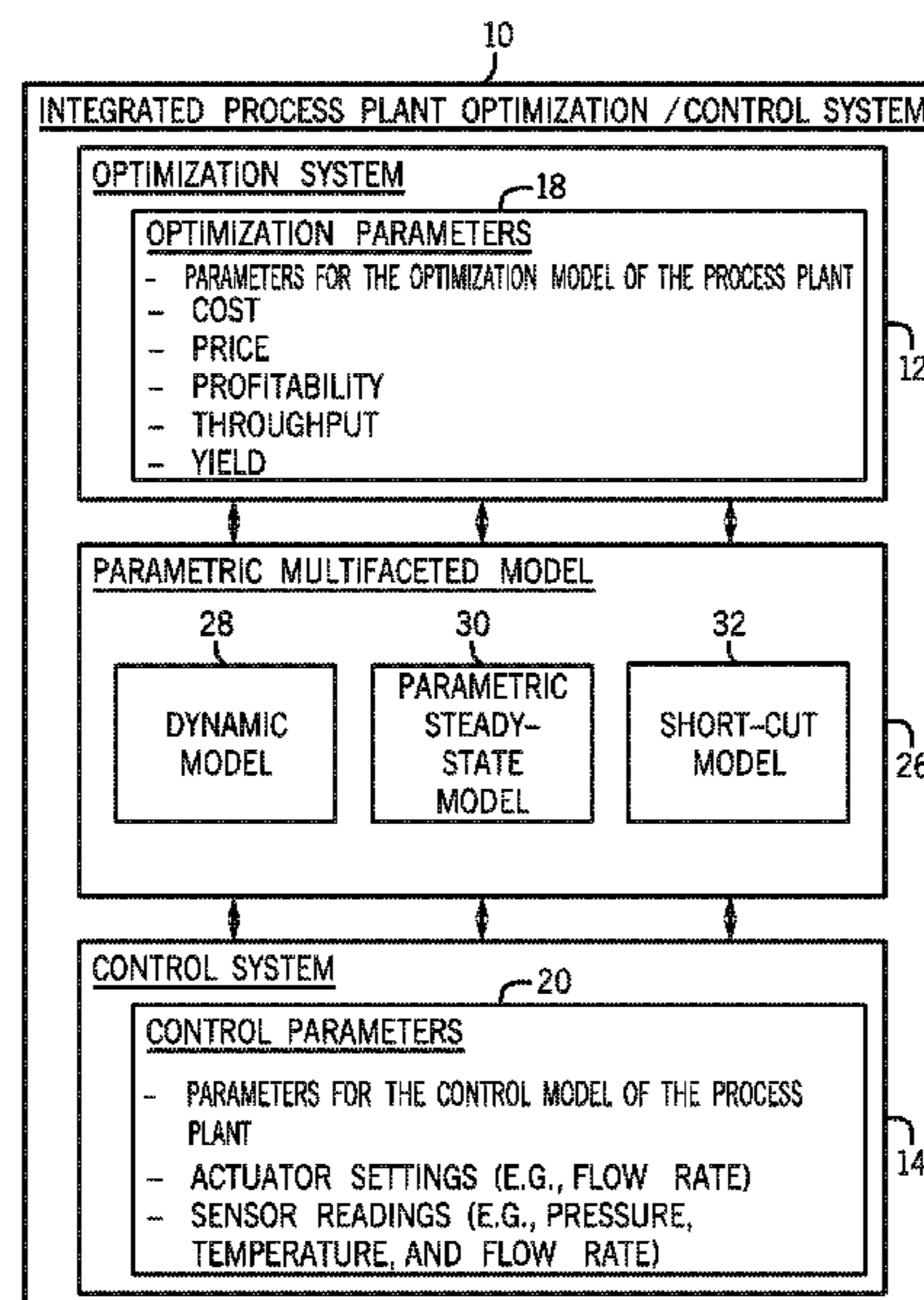

(56)

References Cited

U.S. PATENT DOCUMENTS

6,122,555	A	9/2000	Lu
6,381,505	B1	4/2002	Kassmann et al.
6,434,435	B1	8/2002	Tubel et al.
6,442,513	B1	8/2002	Cheng et al.
7,050,863	B2	5/2006	Mehta et al.
7,194,318	B2	3/2007	Attarwala
7,257,451	B2	8/2007	Carpency et al.
7,330,767	B2	2/2008	Thiele et al.
7,337,022	B2	2/2008	Wojsznis et al.
7,376,472	B2	5/2008	Wojsznis et al.
2003/0097194	A1	5/2003	Gade et al.
2003/0097243	A1	5/2003	Mays et al.
2005/0187643	A1	8/2005	Sayyar-Rodsari et al.
2007/0156288	A1	7/2007	Wroblewski et al.
2008/0108048	A1	5/2008	Bartee et al.

OTHER PUBLICATIONS

Yliniemi, LEENA: "Advanced Control of a Rotary Dryer"; Department of Process Engineering, University of Oulu, Oulu, Finland, May 1999.

Extended European Search Report for related European Application No. 10189335.2, dated Feb. 11, 2011, 6 pgs.

* cited by examiner

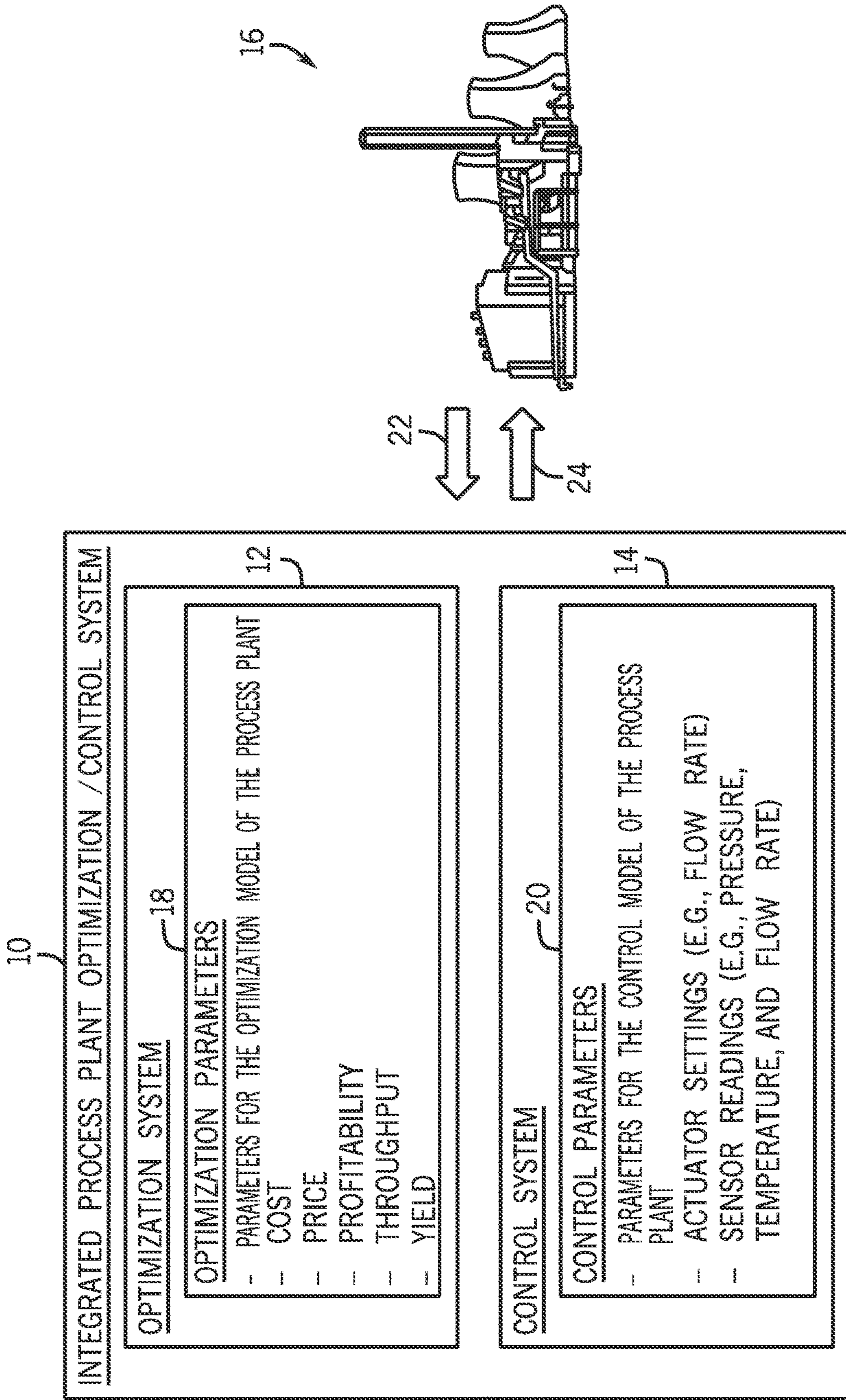

FIG. 1

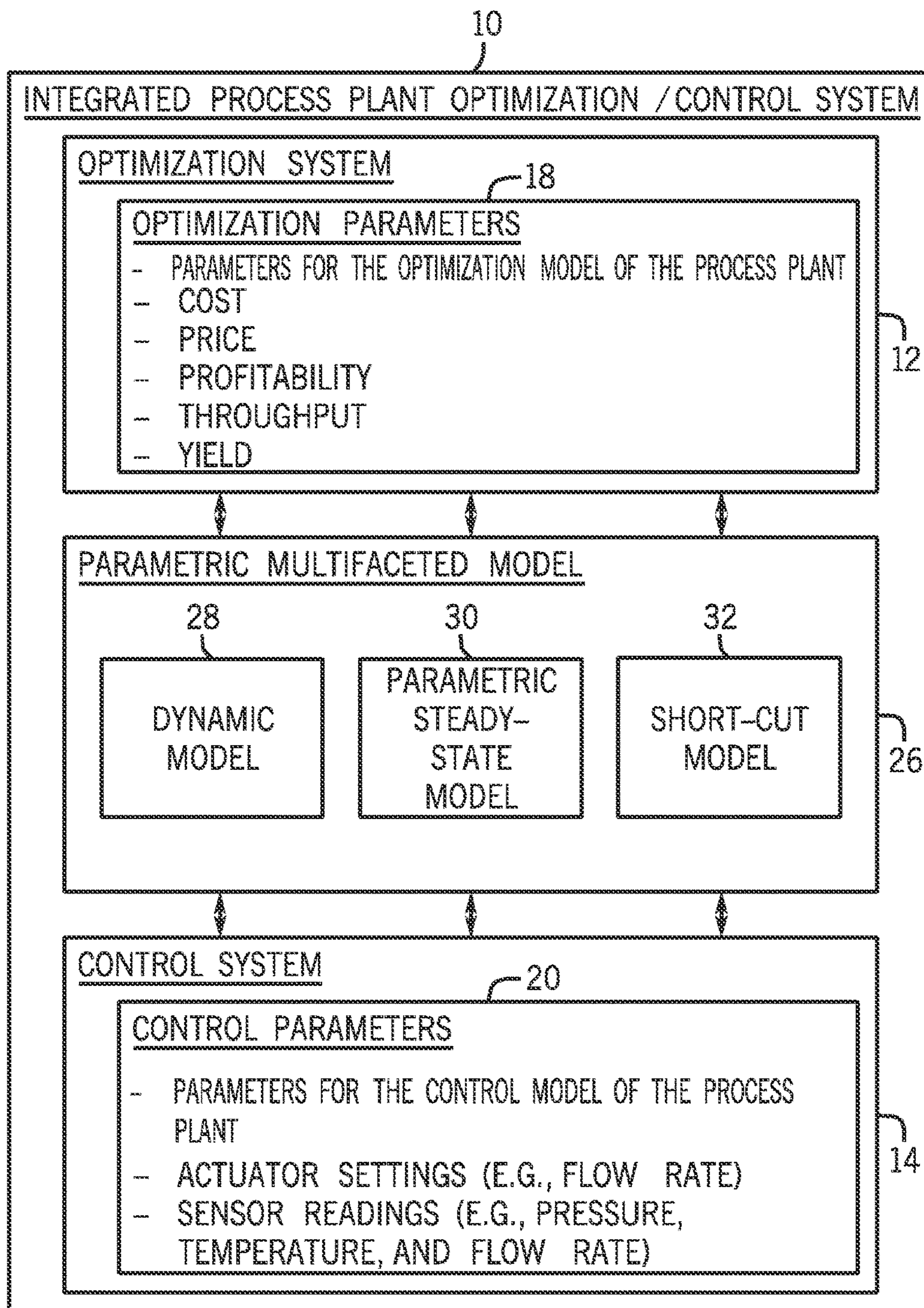

FIG. 2

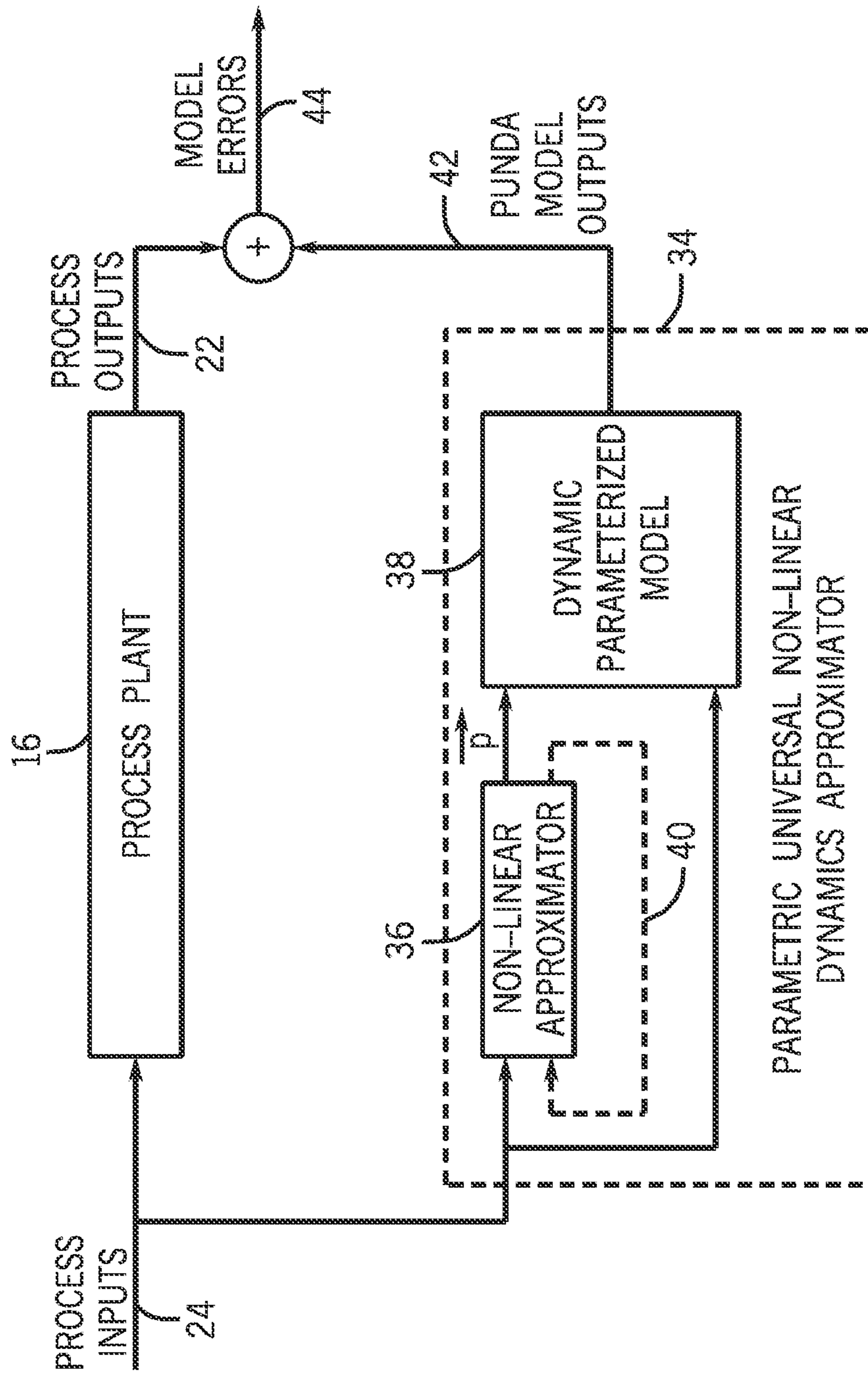

FIG. 3

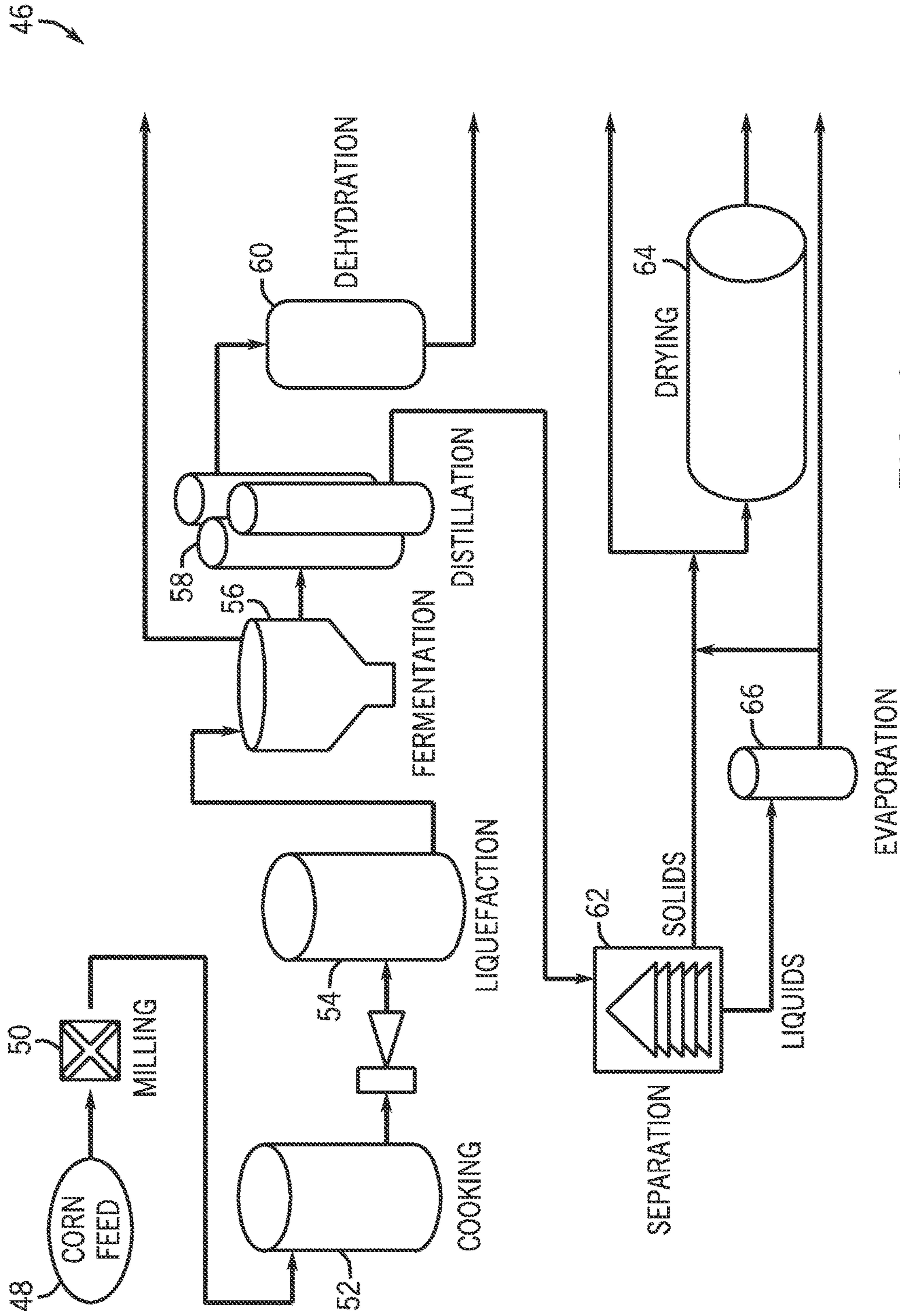

FIG. 4

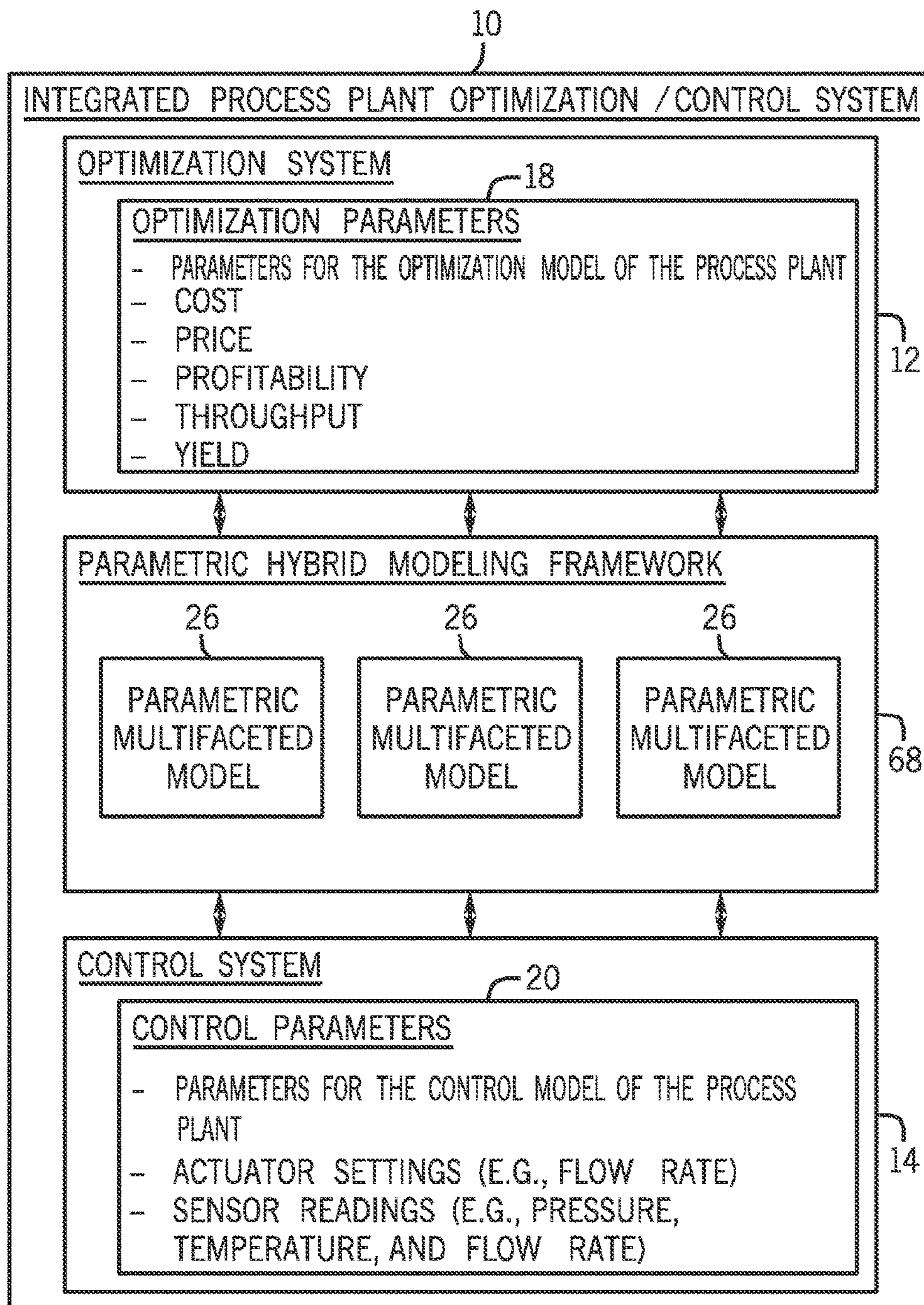

FIG. 5

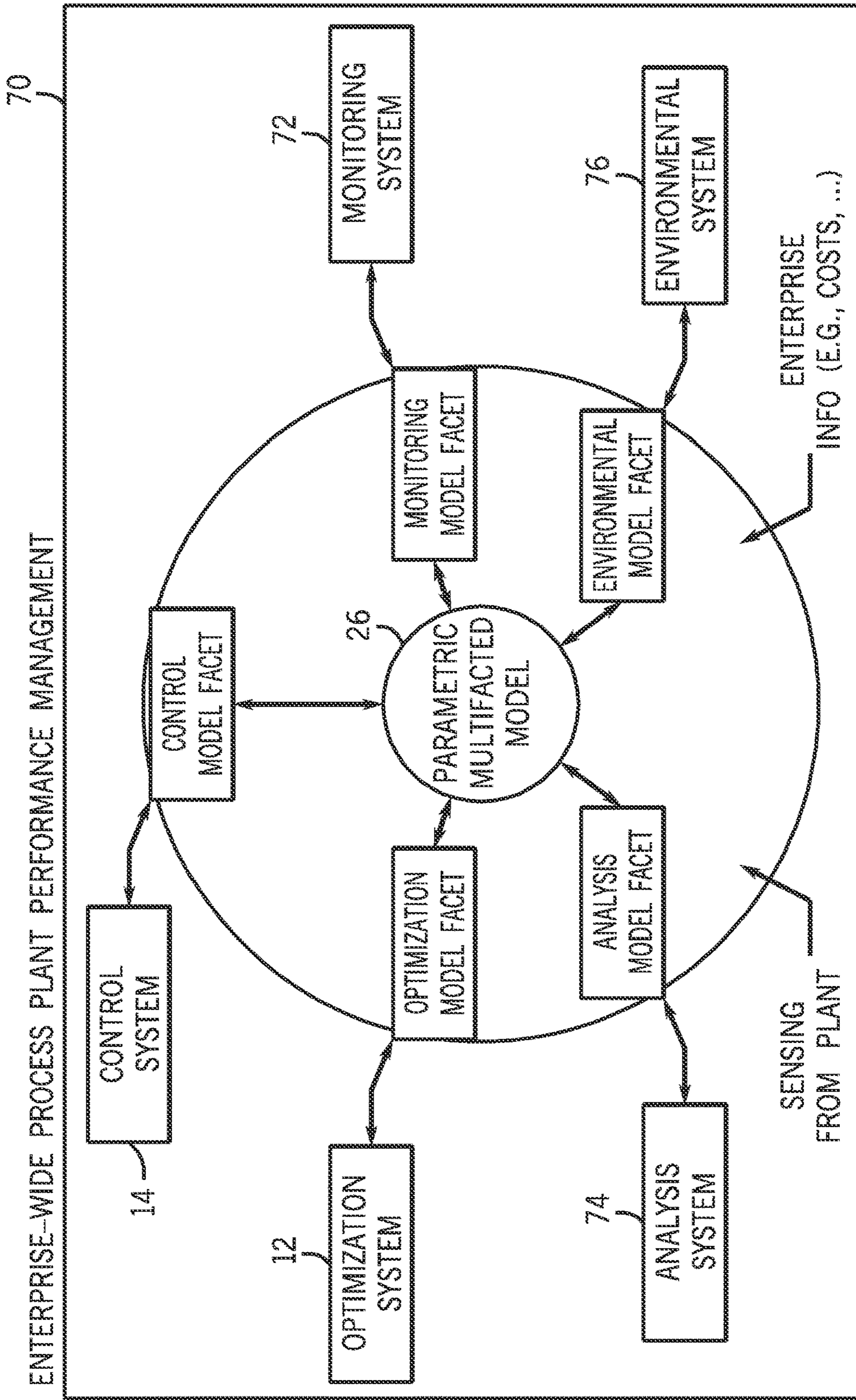

FIG. 6

1**INTEGRATED OPTIMIZATION AND
CONTROL FOR PRODUCTION PLANTS****CROSS-REFERENCE TO RELATED
APPLICATION**

This application is a continuation of U.S. patent application Ser. No. 12/609,785, which was filed on Oct. 30, 2009, which is incorporated by reference herein in its entirety for all purposes.

BACKGROUND

The present invention relates generally to control systems and, more particularly, to integrated optimization and control for production plants using parametric multifaceted models.

Integrated optimization and control of process plants has long been of interest due to the potential economic benefits that such an approach could offer. A number of solutions have been proposed in the past and some commercially available software offerings have attempted to meet the enormous demand for such solutions. However, some key technological challenges to the implementation of such solutions have persisted, including: (1) inconsistencies between plant optimization and plant control solutions, (2) computational complexity of the integrated optimization and control solution, and (3) scalability and maintainability of the integrated solution for complex process plants.

BRIEF DESCRIPTION

The present invention provides novel techniques for optimizing and controlling production plants using parametric multifaceted models. In particular, the parametric multifaceted models may be configured to maintain the consistency of a first set of parameters (e.g., parameters of a dynamic model used for control) relating to a production plant with a second set of parameters (e.g., parameters of an economic model used for economic optimization) relating to the production plant. In general, the first set of parameters will be different than the second set of parameters. For example, the first set of parameters may be indicative of low-level, real-time control parameters and the second set of parameters may be indicative of high-level, economic parameters. Utilizing appropriate parameterization may allow the parametric multifaceted models to deliver an appropriate level of detail of the production plant for the decision-making context within a reasonable amount of time. In particular, the parametric multifaceted models may map the first set of parameters into the second set of parameters in a time horizon allowing for control of the process plant by a control system based on the second set of parameters. In certain embodiments, the mapping may be a function of current and/or anticipated operating conditions of the process plant.

DRAWINGS

These and other features, aspects, and advantages of the present invention will become better understood when the following detailed description is read with reference to the accompanying drawings in which like characters represent like parts throughout the drawings, wherein:

FIG. 1 is a block diagram of an exemplary embodiment of an integrated process plant optimization and control system;

2

FIG. 2 is a block diagram of an exemplary embodiment of the integrated process plant optimization and control system of FIG. 1 having a parametric multifaceted model;

FIG. 3 is a block diagram of an exemplary embodiment of a parametric non-linear dynamic approximator (PUNDA) model, coupled to a physical process or a representation thereof, for purposes of training the PUNDA model for use with the parametric multifaceted model of FIG. 2;

FIG. 4 is a block diagram of an exemplary embodiment of an ethanol production plant, which may use the integrated process plant optimization and control system of FIG. 1;

FIG. 5 is a block diagram of an exemplary embodiment of the integrated process plant optimization and control system having a parametric hybrid modeling framework for managing the various parametric multifaceted models of FIG. 2; and

FIG. 6 is a block diagram of an exemplary enterprise-wide process plant architecture, within which the integrated process plant optimization and control system of FIG. 1 may be utilized.

DETAILED DESCRIPTION

Turning now to the drawings, and referring first to FIG. 1, an integrated process plant optimization and control system 10 is illustrated. The integrated process plant optimization and control system 10 may include both an optimization system 12 and a control system 14. The optimization system 12 may generally be used to optimize the operations of one or more process plants 16 of the integrated process plant optimization and control system 10. For example, the optimization system 12 may typically be used by plant managers, regional managers, and other high-level executives to optimize the operations of the one or more process plants 16. As such, the optimization parameters 18 typically used in conjunction with the optimization system 12 may include cost data (e.g., of material inputs), price data (e.g., of manufactured outputs), profitability of individual plants, overall profitability, throughput constraints of individual plants, overall throughput constraints, yield models of individual plants, overall yield models, equipment efficiency, and so forth. Conversely, the control system 14 may generally be used to control the operations of the one or more process plants 16 of the integrated process plant optimization and control system 10. As such, the control parameters 20 typically used in conjunction with the control system 14 may include parameters of the process plant 16 model (e.g. reaction rates for a fermentation process, process gains, process residence times, and so forth) that may depend on process plant measurements (e.g. sensor readings, such as measurements of temperatures, pressures, flow rates), actuator settings, and so forth.

In other words, the optimization system 12 and the control system 14 may function on two different levels. For example, the optimization system 12 may be concerned with optimizing the performance of the one or more process plants 16. As such, the optimization system 12 may receive process outputs 22 and process inputs 24 from the one or more process plants 16, to modify the optimization parameters 18 of an appropriate model of the process plants 16, which is used by the optimization system 12. These optimization parameters 18 may then be used to optimize the one or more process plants 16 by, for instance, modifying process inputs 24 which may be sent to the one or more process plants 16. Conversely, the control system 14 may be concerned with low-level, real-time control of the one or more process plants 16. As such, the control system 14 may

receive the process outputs **22** and process inputs **24** from the one or more process plants **16**, to modify the control parameters **20**. These control parameters **20** may then be used to control the one or more process plants **16** by, for instance, modifying the process inputs **24** which may be sent to the one or more process plants **16**. The consistency of the decisions by the optimization system **12** and the control system **14**, as described in greater detail below, may be more effectively maintained if the control parameters **20** and the optimization parameters **18** remain consistent. The parametric multifaceted model described herein maintains this consistency by treating the optimization parameters **18** and the control parameters **20** as different facets of an underlying multifaceted model, where the mapping between various facet parameters is an integral part of the multifaceted model.

It should be noted that, although the disclosed embodiments focus on parameterization between the optimization system **12** and the control system **14**, the disclosed embodiments may be extended to parameterization between any number of systems utilizing different facets of a multifaceted model. Indeed, multiple levels of parameterization (e.g., parameterization between a first and second sets of parameters, parameterization between the second set of parameters and a third set of parameters, parameterization between the third set of parameters and a fourth set of parameters, and so forth) may be utilized by the integrated process plant optimization and control system **10**.

A main objective of the integrated process plant optimization and control system **10** is to enable real-time, integrated optimization and control of a complex process plant **16**, and to address the real-world challenges that have hindered successful deployment of such solutions in process plants **16**. As discussed above, in the past, some of the key technological challenges to the implementation of the integrated process plant optimization and control system **10** were: (1) inconsistencies between the optimization system **12** and the control system **14**, (2) computational complexity of the integrated process plant optimization and control system **10**, and (3) scalability and maintainability of the integrated process plant optimization and control system **10** for complex process plants **16**.

Inconsistencies between the optimization system **12** and the control system **14** may be a problem in that the optimization system **12** may often produce solutions that the control system **14** finds infeasible to execute. Several factors may contribute to these inconsistencies. For instance, as described above, the models for optimization and control may be fundamentally different, and may be deployed in complete isolation from one another. For example, a detailed dynamic model used by the control system **14** (e.g., a first principles model of the physical interactions of the process plant **16**) may not be particularly relevant to the optimization system **12**, which may only be interested in optimizing, for example, economic attributes of the process plant **16**. A framework for generating and maintaining a consistent set of models for appropriate contexts is provided by the disclosed embodiments to address these inconsistencies.

Furthermore, when a process plant **16** includes batch-type processing, the modeling challenge may be further complicated by the fact that, oftentimes, the real measure of batch success or failure may only be assessed at the termination of the batch process. However, the batch outcome may be influenced by how the batch progresses over the duration of the batch process. In other words, the optimization system **12** may only be able to identify success or failure of the batch process once the batch process is complete. However,

the control system **12** may need to monitor and control the batch process during the entire batch process. As such, the continuous measurement of the batch process should correlate with the eventual batch outcome. The disclosed embodiments enable different processes throughout the process plant **16** to be optimized and controlled based on parameterized information appropriate for both the particular level of optimization and control and differing time constraints.

In addition, outdated and inaccurate operation constraints will be minimized by the disclosed embodiments. The correct communication of constraint information is not simply a matter of timely communication of information. Rather, process plants **16** are dynamic entities, and proper optimization of the process operation setpoints requires adequate handling of the process plant dynamics. For example, the process plant dynamics may vary as a function of operating conditions of the process plant **16**, and failure to properly account for this variation could lead to infeasible targets for the completion of tasks, adversely affecting the overall performance of the integrated process plant optimization and control system **10**.

Computational complexity of the integrated process plant optimization and control system **10** may be a problem due to the highly complex nature of process plants **16**. As such, process plant optimization and control generally cannot be carried out using a single formulation. In particular, attempting to do so may yield a computationally infeasible optimization solution given the complexity of process plants **16** and the requirements for timely conclusion of the optimization. More specifically, the problem description for economic optimization of the process plant **16** used by the optimization system **12** may typically be expressed as a linear programming problem with integer decision variables whereas the control problem used by the control system **14** may typically include non-linear programming (containing quadratic costs, time-varying non-linear dynamics, and potentially time-varying constraints) with continuous decision variables. The disclosed embodiments accommodate appropriate problem description at each level, enable programmatic modification of the models, and enable the inclusion of appropriate solver technology.

The scalability and maintainability of the integrated process plant optimization and control system **10** for complex process plants **16** may be affected by several main considerations. For example, the enormous size of the mathematical representations of the process plant **16** used by the control system **14**, the diversity of the model types (e.g. first-principles and empirical models, dynamic and steady-state models, mass and energy balance equations) used by the control system **14**, and the diversity of objectives and constraints used by the optimization system **12** present significant challenges. The disclosed embodiments enable manageable integration, modification, and consolidation of the diverse models.

In addition, the need for timely results from the optimization system **12** for online deployment of the integrated process plant optimization and control system **10** makes computational efficiency a critical requirement. Maintaining this computational efficiency as the problem size grows is critical for a viable solution in any real process plant **16**.

FIG. **2** is a block diagram of an exemplary embodiment of the integrated process plant optimization and control system **10** of FIG. **1** having a parametric multifaceted model **26**, which is configured to address the technological challenges discussed above. The parametric multifaceted model **26** may be for an individual process plant **16** or multiple process plants **16** which may be optimized by the optimized system

12. Using the parametric multifaceted model 26, the integrated process plant optimization and control system 10 may always have appropriate modeling available for the specific process. The parametric multifaceted model 26 may be stored on a machine readable memory medium of a computer system, and executed by a processor using program instructions to implement the operations described herein.

In particular, a main challenge addressed by the parametric multifaceted model 26 is the compromise between accuracy and computational efficiency within the context of the relevant optimization problem. For example, while a detailed non-linear dynamic model of a reactor may be required by the control system 14 for a control strategy to work for the reactor, the details of the non-linear dynamics are not necessarily required by the optimization system 12 when one determines the production level at which the reactor must operate. Therefore, the parametric multifaceted model 26 may be used to represent an appropriate level of detail for the process plant 16, depending on the particular optimization or control function.

For example, the parametric multifaceted model 26 for a process plant 16 may include a detailed dynamic model 28 of the process plant 16. The dynamic model 28 may, for instance, be suitable for use by a model predictive control (MPC) controller. The parametric multifaceted model 26 may also include a parametric steady-state model 30 of the process plant 16. The parametric steady-state model 30 may, for instance, be suitable for use in a set-point/what-if scenario analysis. The parametric multifaceted model 26 may also include a "short-cut" model 32, which may, for instance, be a parametric mass and energy balance model in the form of an open-equation that is suitable for process plant optimization. Each model may be treated as a view into the underlying process and the consistency between the different views may be maintained by a parametric multifaceted mapping in a hybrid modeling framework, as described in greater detail below.

In a simplified scenario, the process plant 16 would have a single model representing its dynamic model 28, parametric steady-state model 30, and short-cut model 32. For example, a simple gain, time constant, time-delay description of a vessel (e.g., a tank) or other piece of equipment in a process plant 16 may provide appropriate information for the dynamic model 28, the parametric steady-state model 30, and the short-cut model 32 of the vessel. However, this simplified scenario may not be applicable and/or desirable in all circumstances. In this instance, the dynamic models 28, parametric steady-state models 30, and short-cut models 32 may be tied to each other via parametric multifaceted mapping in a multi-faceted model. In other words, the parametric multifaceted mappings may be secondary models which relate the primary models to each other.

A key advantage of the parametric multifaceted model 26 is the ability to systematically build consistent models for various optimization contexts of interest for a process plant 16. The parametric multifaceted model 26 may be a key enabling technology for the integration of planning, scheduling, sequencing, and control in a manufacturing enterprise. For example, the parametric multifaceted model 26 may be capable of generating relevant parameters for the optimization system 12 over a time horizon enabling optimization of the process plant 16 in a timely manner.

Parametric non-linear dynamic approximator (PUNDA) models may be used as an accurate and computationally efficient representation for the complex dynamic behavior of the process plant 16. The fundamental concepts of PUNDA models can be found in U.S. Patent Application Number

2005/0187643, which is hereby incorporated by reference. In particular, FIG. 3 is a high-level block diagram of an exemplary embodiment of a PUNDA model 34, coupled to the process plant 16 or a representation thereof, for the purpose of training the PUNDA model 34 for use with the parametric multifaceted model 26 of FIG. 2. The PUNDA model 34 may be stored on a memory medium of a computer system, and executed by a processor using program instructions to implement the operations described herein.

In the embodiment illustrated in FIG. 3, the PUNDA model 34 includes a non-linear approximator 36 coupled to a dynamic parameterized model 38 in series. In certain embodiments, the non-linear approximator 36 may be a support vector machine, neural network, statistical model, parametric description, Fourier series model, or any other type of empirical or data based model. The non-linear approximator 36 may be a universal non-linear approximator, such that any type of non-linear mapping may be implemented. The non-linear approximator 36 operates to provide parameters \vec{p} to the dynamic parameterized model 38, as shown. As indicated, in certain embodiments, the non-linear approximator 36 may also include a feedback loop 40, whereby the output of the non-linear approximator 36 is provided as further input to itself, thus supporting dependencies of the output upon prior output of the non-linear approximator 36. In certain embodiments, the dynamic parameterized model 38 may be a multi-input, multi-output (MIMO) dynamic model implemented with a set of difference equations (e.g., a set of discrete time polynomials), an example of which is provided below. Thus, the dynamic parameterized model 38 may receive its parameters \vec{p} from the non-linear approximator 36, and operate accordingly.

As illustrated in FIG. 3, the PUNDA model 34 may be coupled to the process plant 16 or a representation of the process plant 16. Process inputs 24 may be provided to the process plant 16 and to the PUNDA model 34 as inputs. The process plant 16 produces process outputs 22, which may be combined or used with PUNDA model outputs 42 to determine model errors 44, as shown. These model errors 44 may then be provided back to the PUNDA model 34 and used (e.g., with an optimizer) to train the PUNDA model 34. The PUNDA model 34 is described herein in terms of a series combination of a non-linear model and a set of MIMO difference equations that can be used to model any complex non-linear dynamic system with any desired degree of accuracy. Although, as noted above, other non-linear approximators and dynamic parameterized models are also contemplated.

For example, in various embodiments, the process plant 16 of FIG. 3 may be described or represented by the process plant 16 itself, a first principles model, empirical data, or a combination thereof, among others. Examples of first principles models include a state space description of the process plant 16 in the form of $x_{k+1}=F_k(x_k, u_k, p_k)$, $y_k=G_k(x_k, u_k, p_k)$, or input/output difference equations in the form of $y_k=G_k(y_{k-1}, \dots, y_{k-N}, u_k, \dots, u_{k-M}, p_k)$. Here, x_k is the state vector, u_k is the input vector (manipulated or disturbance variables), p_k is the parameter vector, and y_k is the output vector for the process plant 16. Examples of empirical data include test data for all process inputs and outputs 24, 22, or correlated measurements from normal operation of the process plant 16 for certain input and output pairs. Other representations are also contemplated including, for example, statistical models, parametric descriptions, Fourier series models, and empirical models, among others.

The PUNDA model **34** allows the empirical information and/or the first principles knowledge available about the process plant **16** to be systematically used in building a computationally favorable (i.e., efficient) model of the process plant **16** that is suitable for online optimization and control of the process plant **16**. In other words, the computations may be made in substantially real time. Additionally, the PUNDA model **34** may be capable of approximating the non-linear process plant **16** with any desired degree of accuracy, as will be described in detail below.

It is noted that partial first principle models that, by themselves, are not sufficient to fully describe the process plant **16** could be used to build a representative model of the process plant **16** with the PUNDA model **34**. The non-linear approximator **36** in the PUNDA model **34** may be trained while it is serially connected to the dynamic parameterized model **38** and hence, in general, the output of the non-linear approximator **36** may not be directly available. It is expected that the complexities of the real world process plant **16** may dictate the need for the training of the non-linear approximator **36** in a majority of the applications.

A preferred methodology for training the non-linear approximator **36** within the PUNDA architecture of FIG. **3** is to formulate the training of the parameters as a constrained non-linear programming problem. This constrained non-linear programming problem may then be solved with any appropriate non-linear programming solver.

The present modeling approach focuses on successful optimization and control by accurately capturing both process gains and dynamics. To ensure the high fidelity of the PUNDA model **34** for optimization and control, the constrained non-linear programming problem for the training of the non-linear approximator **36** may include constraints on the derivatives (of any desired order) of the process outputs **22** with respect to the process inputs **24**. Other constraints, for example, mass and energy balances, may also be included. Potential sources of information for such constraints include first principle models and operator knowledge. A variety of techniques may be used to translate such information into constraints for the non-linear programming problem. For example, one approach is to use software to derive analytical expressions for the first (or higher order) derivatives of the outputs with respect to the inputs in extremely sophisticated first principle models. The derived expressions may then be included in the constraint set for the non-linear programming problem of training. In addition to the derivative constraints (e.g., gain constraints), the training of the PUNDA model **34** may be constrained to ensure desired dynamic behavior for the PUNDA model **34**. For example, a time constant in the system may be bounded to a certain range based on prior knowledge about the physics of the process plant **16**.

In the PUNDA model **34**, the notion of decomposing the non-linear dynamic behavior of the process plant **16** into linear (or even non-linear) dynamics and static input/output mappings is avoided. Rather, in the PUNDA model **34**, the identification of the dynamic behavior of the process plant **16** and the input/output static mappings (i.e. gain relationships) are performed simultaneously. The non-linear approximator **36** in the PUNDA model **34** specifies how the parameters of the dynamic parameterized model **38** (e.g., the MIMO difference equation block) may vary as a function of process operating conditions, and gain and dynamic behavior of the PUNDA model **34** is a global property of the entire PUNDA model **34**. Therefore, a desired gain behavior may

be enforced on the training of the PUNDA model **34** in precisely the same way that a desired dynamic behavior is enforced.

Returning now to FIG. **2**, the output of the PUNDA model **34** will be one or more facets of parametric multifaceted models **26** which enable the integrated process plant optimization and control system **10** always to function using an appropriate level of detail for the process plant **16**, depending on the particular function. For example, in some instances, the integrated process plant optimization and control system **10** may only need a less-detailed view of the process plant **16**, which may be provided by a short-cut model **32**. Whereas, in other instances, the integrated process plant optimization and control system **10** may need a more detailed view of the process plant **16**, which may be provided by a dynamic model **28**. As such, the parametric multifaceted models **26** may always be capable of functioning using an appropriate level of detail within a time horizon which may, for example, enable control of the process plant **16** by the control system **14**.

The following is an illustrative example of the types of models generated as part of the parametric multifaceted models **26**. The techniques described herein may be applied to various process plants **16**, both upon initial commissioning, and as a retrofit. For example, FIG. **4** is a block diagram of an exemplary embodiment of an ethanol production plant **46**, which may use the integrated process plant optimization and control system **10** of FIG. **1**. There are currently approximately 134 ethanol production plants in the United States with a production capacity of nearly 7.2 billion gallons per year, with an additional 6.2 billion gallons per year capacity under construction. Approximately two-thirds of these are dry-mill production facilities.

In the ethanol production plant **46**, corn feed **48** is provided to milling and cooking processes **50**, **52** where it is broken down chemically to increase the surface area to volume ratio. This increase in surface area allows for sufficient interaction with water to achieve a solution of fermentable sugars, known as beer mash. The beer mash is heated to promote an increase in the amount of biomass-water contact in solution and to increase the separation of carbohydrate biomass from the non-carbohydrate biomass. Enzymes, such as alpha-amylase, are typically added in a liquefaction process **54** to promote further breakdown of long-chained carbohydrate polymers. The beer mash is then sent to a fermentation process **56**, where several fermentation tanks operate to ferment the beer mash slurry.

The beer mash is typically pumped into the fermentation tanks along with a propagation mixture consisting of yeast, a second enzyme (e.g., glucoamylase), a nitrogen source, and an antibiotic. While in the fermentation tanks, the glucoamylase converts dextrans to dextrose, which the yeast then converts to primary products of ethanol, carbon dioxide, and heat. A number of fermentation tanks are used on a rotating basis, providing a continuous flow through the ethanol production plant **46**. The batch time in each fermentation tank is determined by the beer mash flow through the ethanol production plant **46**.

The output from the fermentation process **56** is sent to a distillation process **58** to separate ethanol from water, carbon dioxide, and non-fermentable solids (i.e. stillage). The ethanol is further dehydrated in dehydration units **60** to moisture levels less than 5% by a particular processing unit called a molecular sieve. The final 200-proof ethanol is then processed to ensure it is denatured and not used for human consumption.

Stillage (e.g., non-fermentable solids and yeast residue), the heaviest output of the distillation process **58**, is sent to stillage processing units **62** for further processing of co-products from the ethanol production plant **46**. The stillage processing units **62** separate additional water from the cake solids and recycle the water back to the milling and cooking units **50**, **52**. Centrifuges are used to remove excess water (e.g., thin stillage) from the distillers grain and this product can be sold as wet cake consisting of approximately 65% moisture. The wet cake can be further processed by dryers **64** to approximately 10% moisture and sold as dried distillers grain.

A portion of the thin stillage liquids may be recycled back to the fermentation process **56**. However, the bulk of the flow is generally sent to evaporator units **66**, where more liquid is separated from the liquid stream, causing the liquid stream to concentrate into syrup, which may then be sent to a syrup tank. The syrup can be processed in various ways. For example, it may be sprayed into the dryers **64** to a specified color or moisture. Further, it may be added to the partially dried stillage product, or it may be sold as a liquid product.

An energy center supplies energy to the various processing units, for instance, the milling and cooking units **50**, **52**, the distillation and mole-sieve units **58**, and the stillage processing units **62**. The energy center typically constitutes a thermal oxidizer unit and heat recovery steam generator that provides steam to the processing units. The energy center is typically the largest source of heat in the ethanol production plant **46**.

To demonstrate the use of parametric multifaceted models **26** for the integrated process plant optimization and control system **10**, the focus will be on the dryers **64** of the ethanol production plant **46**. The dryer dynamics for control purposes may be described as follows:

$$\frac{\partial X_{s,out}}{\partial t} + \frac{V_s(X_{s,out} - X_{s,in})}{L} = -R_w \quad (\text{Eq. 1})$$

$$C_s \left(\frac{\partial T_{s,out}}{\partial t} \right) + \frac{V_s C_s (T_{s,out} - T_{s,in})}{L} = \left(\frac{U_v V_v}{F_s} \right) (T_{g,out} - T_{s,out}) - \lambda R_w \quad (\text{Eq. 2})$$

$$C_g \left(\frac{\partial T_{g,out}}{\partial t} \right) + \frac{V_g C_g (T_{g,out} - T_{g,in})}{L} = - \left(\frac{U_v V_v}{F_g} \right) (T_{g,out} - T_{s,out}) - \lambda \left(\frac{F_s}{F_g} \right) R_w \quad (\text{Eq. 3})$$

where $X_{s,out}/X_{s,in}$ is the solid moisture at the exit/entrance of the dryers **64**, V_s is the linear velocity of the solids in an axial direction, L is the dryer length, R_w is the drying rate, $T_{s,out}/T_{s,in}$ is the solid temperature at the exit/entrance of the dryers **64**, C_s is the heat capacity of the solids, U_v is the volumetric heat transfer coefficient, V_v is the drum volume per unit length, F_s is the linear density of the solids, λ is the heat vaporization of the water, $T_{g,out}/T_{g,in}$ is the drying air temperature at the exit/entrance of the dryers **64**, C_g is the heat capacity of the drying air, and F_g is the linear density of the drying air. It should be noted that R_w is a non-linear function of solid characteristics and drying air temperature.

Historically, the control of the dryers **64** has proven to be difficult due to the long time delays involved. In particular, disturbances in input moisture content, temperature, or flow of the solids will disturb the process for long periods of time, and the disturbances are usually not observable until they are measured at the exit of the dryers **64**. Therefore, the control scheme often includes both feedback and feedforward com-

ponents. The most common control loop is the control of fuel flow based on the moisture content of the output solids. A combined feedforward and feedback control strategy may include loops for fuel flow, residence time, rotational speed of the drum, drying air flow, and mass flow, among others.

For the economic optimization of the ethanol production plant **46**, however, the main variable of interest may be the moisture content of the solids at the exit of the dryers **64** and the production rate of the final dried distillers grain. The energy consumption that is associated with this level of production and drying, along with the specification and price for the wet versus dried solids, contribute to the optimum solution for the dryers **64**. More specifically, a shortcut model **32** for economic optimization of the ethanol production plant **46** may include the following mass balance equations for the water and ethanol content of the solids entering/exiting the dryers **64**:

$$\text{Exit_WaterComponent} = (1 - \epsilon_{H2O}) \text{Input_Water} \quad (\text{Eq. 4})$$

$$\text{Exit_EthanolComponent} = (1 - \epsilon_{eth}) \text{Input_Ethanol} \quad (\text{Eq. 5})$$

where ϵ_{H2O} and ϵ_{eth} are the coefficients that depend on the controller performance in removing the water and ethanol from the solids.

A parametric multifaceted model **26** may systematically relate the shortcut models **32** for economic optimization (e.g., Equations 4 and 5) to the detailed dynamic models **28** for control (e.g., Equations 1-3) by explicitly modeling ϵ_{H2O} and ϵ_{eth} as functions of the manipulated variables that control $X_{s,out}/X_{s,in}$ in Equation 1 (e.g., as a function of fuel flow and/or mass flow). In general, more complex relationships may be needed to properly represent the controller performance in the economic optimization of the ethanol production plant **46**. It should be noted that the controller constraints in the achievable moisture level in the exit of the dryers **64** (e.g., due to the temperature constraints) may be easily reflected in constraints on ϵ_{H2O} and ϵ_{eth} and, hence, may maintain the consistency of the economic optimization with the dryer controller performance.

As described above, there may be more than one parametric multifaceted model **26** used for a specific process plant **16** or series of process plants **16**. As such, a framework for managing the various parametric multifaceted models **26** may be used. FIG. **5** is a block diagram of an exemplary embodiment of the integrated process plant optimization and control system **10** having a parametric hybrid modeling framework **68** for managing the various parametric multifaceted models **26** of FIG. **2**. While the context of the optimization system **12** generally determines the appropriate model type, the ability to consistently define, update, and maintain relevant models in the proper context may present a significant challenge. This parametric hybrid modeling framework **68** may include a software framework in which various parametric multifaceted models **26** are defined, modified, deployed (e.g., in a variety of contexts that include offline simulation, software online analysis, and online optimization), and maintained.

More specifically, the parametric hybrid modeling framework **68** accommodates efficient definition of parametric multifaceted models **26** in a manner that is intuitive for the particular model type (i.e., dynamic model **28**, parametric steady-state model **30**, or short-cut model **32**). The software enables the user to view, probe, and deploy various views of the parametric multifaceted model **26** and allows for programmatic tracing of a specific view of the parametric

multifaceted model **26** wherever it is used (e.g., a combined model, a deployed optimization solution, or a simulation model).

The parametric hybrid modeling framework **68** also accommodates easy and seamless online and offline modification of parametric multifaceted models **26**. Robust online modification of the parameters of each model may prove to be instrumental to the successful implementation of the integrated process plant optimization and control system **10**. The parametric hybrid modeling framework **68** may allow for constrained modification of the parameters of the parametric multifaceted models **26** where the constraints are modifiable programmatically via the parametric hybrid modeling framework **68**. Of particular significance may be logical constraints that the parametric hybrid modeling framework **68** correctly includes in the optimization problem statements.

The parametric hybrid modeling framework **68** also enables combining parametric multifaceted models **26** into parametric multifaceted models **26** for proper optimization and control contexts. The connectivity information in the combined model may be maintained in a transparent manner. The ability to build a transparent hierarchy of parametric multifaceted models **26** may prove beneficial to the success of the integrated process plant optimization and control system **10**. This is in part due to the fact that, in certain applications, oftentimes the sheer size of the process plant model may pose a significant challenge in model management.

One of the beneficial aspects of the disclosed embodiments is constrained modification of the parametric multifaceted models **26** for optimization and control computations. Process plants **16** are typically extremely dynamic entities. The behavior of process plant optimization and control modules may vary as a function of dynamic process plant operating conditions. Changing market conditions will affect the cost of raw material, the cost of energy, the demand for the products, the price of the goods sold, and so forth. The integrated process plant optimization and control system **10** is equipped to handle this dynamic nature of process plants **16**. In particular, the disclosed embodiments enable constrained modification of the optimization system **12**, which may include models for process plant modules, models of operation constraints, and operation priorities and objectives, among others. The constrained modification may be accomplished in both an adaptive manner (e.g., via modification of a present time representation of the process plant **16**) and a predictive manner (e.g., via modification of a representation of the process plant **16** over a relevant decision/prediction horizon). The constrained modification may be based on both the current state of the process plant **16** and an anticipated and/or planned profile over a decision horizon. A representative example of the need for constrained modification of process plant models for the integrated process plant optimization and control system **10** is the case where the optimization system **12** determines a new production level within a given time frame in a polymer process and needs to correctly account for the potentially large variation in delays as a function of production level.

Another beneficial aspect of the disclosed embodiments is the ability to provide a computationally efficient solution of the optimization and control problems in a relevant time horizon through systematic model order reduction and coordinated modular optimization. In the past, timely conclusion of the computations involved in optimization and control of process plants **16** has proven to be an obstacle to the successful deployment of integrated optimization and con-

rol solutions. The disclosed embodiments address this challenge by providing efficient model order reduction using the parametric multifaceted models **26** such that the resulting optimization problems are of considerably lower dimension allowing, for instance, optimization parameters to be generated in a time horizon allowing for substantially real-time control of the process plant **16** by the control system **14**. One example is the use of a model for steady-state representation of a complex process plant **16** where a combination of actual and artificially-generated process plant data are used to consolidate the steady-state view of the complex process plant **16** into a computationally efficient steady-state model that will serve as one view of the combined parametric multifaceted model **26** for the complex process plant **16**.

In addition, the disclosed embodiments address the computational efficiency challenge posed by the scale of integrated optimization and control problems by, among other things: (1) allowing simultaneous use of multiple solver technologies for various optimization problems, (2) enabling timely communication of models and constraints among various optimization problems through appropriately defined parameters in each model, and (3) enabling traceability for the constraints and parameter modifications throughout various optimization problems as a result of the transparent manner by which the parametric multifaceted models **26** are maintained by the parametric hybrid modeling framework **68**. The ability of the parametric hybrid modeling framework **68** to programmatically identify proper model types, relevant constraint sets, solver types, and initial guesses for the solution are a key feature of the disclosed embodiments. In fact, the disclosed embodiments provide a framework for the implementation of a distributed integrated process plant optimization and control system **10** throughout a complex process plant **16**, since the parametric hybrid modeling framework **68** will maintain and manage the integrated process plant optimization and control system **10**, including the models, problem descriptions, solvers, and initial conditions.

The disclosed embodiments may prove beneficial in a wide variety of real world applications including, but not limited to, economically-driven process plant operation, optimal execution of a production plan, and integrated optimization and control of multiple process plants **16**. With respect to economically-drive process plant operation, the optimization system **12** may determine setpoints for the control system **14** based on economic objectives of the process plant **16**. For example, the product type and production level for each product may be determined by the optimization system **12** given the cost of raw materials, energy cost, price of the product in the market, and so forth. With respect to optimal execution of a production plan, a given number of products may be planned for production by the process plant **16** by a given deadline. In this case, the optimization system **12** may determine the optimal production sequence for the process plant **16** given production capability and constraints of the process plant **16**. With respect to integrated optimization and control of multiple process plants **16**, multiple production facilities may be viewed as assets for enterprise-wide optimization of manufacturing operations.

The integrated process plant optimization and control system **10** may be a part of a broader enterprise-wide architecture for managing process plants **16**. For instance, FIG. **6** is a block diagram of an exemplary enterprise-wide process plant architecture **70**, within which the integrated process plant optimization and control system **10** of FIG. **1** may be utilized. As illustrated, in addition to the optimiza-

13

tion system 12 and the control system 14 discussed above, the enterprise-wide process plant architecture 70 may also include a monitoring system 72, an analysis system 74, and an environmental system 76, among others. As illustrated, each of these systems may include their own respective parametric multifaceted model facets. The monitoring system 72 may be used to monitor the operations of the process plants 16 as well as monitoring the other systems of the enterprise-wide process plant architecture 70 to ensure that they are receiving accurate information and adequately acting upon the information. The analysis system 74 may be somewhat related to the other systems of the enterprise-wide process plant architecture 70 in that the analysis system 74 may provide some of the analysis used by these systems. The environmental system 76 may include software for ensuring that the process plants 16 comply with environmental regulatory conditions. The illustrated systems of the enterprise-wide process plant architecture 70 are merely exemplary and not intended to be limiting. All of the illustrated systems of the enterprise-wide process plant architecture 70 may be modular and may include combinations of software and hardware solutions. Furthermore, in certain embodiments, these systems may be digitally linked together.

While only certain features of the invention have been illustrated and described herein, many modifications and changes will occur to those skilled in the art. It is, therefore, to be understood that the appended claims are intended to cover all such modifications and changes as fall within the true spirit of the invention.

The invention claimed is:

1. A system comprising:

a parametric multifaceted model of a plurality of process plants configured to receive inputs from the process plants, and to map between a first set of parameters relating to a first facet of the parametric multifaceted model of the process plants and a second set of parameters relating to a second facet of the parametric multifaceted model of the process plants;

an optimization system configured to optimize integrated operation of the process plants using the second set of parameters and a first parameterized input/output control model, wherein the first parameterized input/output control model comprises a short-cut model; and

a control system configured to control integrated operation of the process plants using the first set of parameters and a second parameterized input/output control model, wherein the second parameterized input/output control model comprises a detailed dynamic model,

wherein the first set of parameters is different than the second set of parameters and mapping between the first set of parameters and the second set of parameters facilitates maintaining consistency between the first parameterized input/output control model and the second parameterized input/output control model, wherein the mapping between the first set of parameters and the second set of parameters is a function of current and/or anticipated operating conditions of the process plants and occurs over a time horizon during operation of the process plants to facilitate control of the process plants; and

wherein the parametric multifaceted model comprises a parametric non-linear dynamic approximator and a dynamic parameterized model coupled in series.

2. The system of claim 1, wherein the first set of parameters comprise control parameters used by the control system and the second set of parameters comprise optimization parameters used by the optimization system.

14

3. The system of claim 2, wherein the optimization parameters comprise production facility constraints, throughput limits, equipment efficiency, or a combination thereof.

4. The system of claim 2, wherein the control parameters comprise reaction rates, process gains, process residence times, sensor readings, actuator settings, or a combination thereof.

5. The system of claim 1, wherein the parametric multifaceted model is configured to map the second set of parameters into the first set of parameters.

6. The system of claim 1, wherein the plurality of process plants comprises an ethanol production plant.

7. A system comprising:

a parametric multifaceted model of a process plant configured to receive inputs from the process plant, and to map between a first set of parameters relating to a first facet of the parametric multifaceted model of the process plant and a second set of parameters relating to a second facet of the parametric multifaceted model of the process plant;

an environmental system configured to determine whether a process plant is operating in compliance with environmental regulatory conditions using the first set of parameters;

a control system configured to control operation of the process plant using the second set of parameters and a first parameterized input/output control model;

an optimization system configured to optimize operation of the process plant using a third set of parameters and a second parameterized input/output control model;

wherein the first set of parameters is different than the second set of parameters and mapping between the first set of parameters and the second set of parameters facilitates maintaining consistency between the environmental system and the control system, wherein the mapping between the first set of parameters and the second set of parameters is a function of current and/or anticipated operating conditions of the process plant and occurs over a time horizon during operation of the process plant to facilitate control of the process plant; and

wherein the first parameterized input/output control model comprises a short-cut model and the second parameterized input/output control model comprises a detailed dynamic model.

8. The system of claim 7,

wherein the parametric multifaceted model is configured to map between the first set of parameter, the second set of parameters, and the third set of parameters, wherein the first set of parameters, the second set of parameters, and the third set of parameters are each different from one another, mapping between the first set of parameters, the second set of parameters, and the third set of parameters facilitates maintaining consistency between control system, the optimization system, and the environmental system, and the mapping between the first set of parameters, the second set of parameters, and the third set of parameters is a function of current and/or anticipated operating conditions of the process plant and occurs over a time horizon during operation of the process plant to facilitate controlling the process plant.

9. The system of claim 7, comprising:

an analysis system configured to provide analysis used by the environmental system, the control system, or both using a third set of parameters;

15

wherein the parametric multifaceted model is configured to map between the first set of parameter, the second set of parameters, and the third set of parameters, wherein the first set of parameters, the second set of parameters, and the third set of parameters are each different from one another, mapping between the first set of parameters, the second set of parameters, and the third set of parameters facilitates maintaining consistency between control system, the analysis system, and the environmental system, and the mapping between the first set of parameters, the second set of parameters, and the third set of parameters is a function of current and/or anticipated operating conditions of the process plant and occurs over a time horizon during operation of the process plant to facilitate controlling the process plant.

10. The system of claim 7, wherein:

a monitoring system configured to monitor operation of the process plant, the environmental system, the control system, or any combination thereof using a third set of parameters;

wherein the parametric multifaceted model is configured to map between the first set of parameter, the second set of parameters, and the third set of parameters, wherein the first set of parameters, the second set of parameters, and the third set of parameters are each different from one another, mapping between the first set of parameters, the second set of parameters, and the third set of parameters facilitates maintaining consistency between control system, the monitoring system, and the environmental system, and the mapping between the first set of parameters, the second set of parameters, and the third set of parameters is a function of current and/or anticipated operating conditions of the process plant and occurs over a time horizon during operation of the process plant to facilitate controlling the process plant.

11. The system of claim 7, wherein the parametric multifaceted model comprises a detailed dynamic model, a steady-state model, and a short-cut model.

12. The system of claim 7, wherein the parametric multifaceted model comprises a parametric non-linear dynamic approximator and a dynamic parameterized model coupled in series.

13. The system of claim 7, wherein the process plant is an ethanol production plant.

14. A tangible, non-transitory, computer-readable medium configured to store instructions executable by a processor of a process plant, wherein the instructions comprise instructions to:

map, using the processor, between a first set of parameters relating to a first facet of a parametric multifaceted model of the process plant and a second set of parameters relating to a second facet of the parametric multifaceted model of the process plant, wherein the first set of parameters is different than the second set of parameters;

map, using the processor, between a third set of parameters relating to a third facet of the parametric multifaceted model of the process plant, the first set of parameters, and the second set of parameters, wherein the third set of parameters is different than the first set of parameters and the second set of parameters;

optimize, using the processor, operation of the process plant using the second set of parameters and a first parameterized input/output control model with an opti-

16

mization system, wherein the first parameterized input/output control model comprises a short-cut model; determine, using the processor, whether the process plant is operating in compliance with environmental regulatory conditions using the third set of parameters with an environmental system; and

control, using the processor, operation of the process plant using the first set of parameters and a second parameterized input/output control model with a control system, wherein the second parameterized input/output control model comprises a detailed dynamic model, wherein:

mapping between the first set of parameters and the second set of parameters facilitates maintaining consistency between the first parameterized input/output control model and the second parameterized input/output control model;

mapping between the first set of parameters and the second set of parameters is a function of current operating conditions of the process plant, anticipated operating conditions of the process plant that occur over a time horizon during operation of the process plant, or both; and

mapping between the first set of parameters, the second set of parameters, and the third set of parameters facilitates maintaining consistency between the control system, the optimization system, and the environmental system.

15. The computer-readable medium of claim 14, comprising instructions to:

map, using the processor, between a third set of parameters relating to a third facet of the parametric multifaceted model of the process plant, the first set of parameters, and the second set of parameters;

determine, using the processor, analysis used by an enterprise system using the third set of parameters with an analysis system;

wherein the first set of parameters, the second set of parameters, and the third set of parameters are each different from one another; and mapping between the first set of parameters, the second set of parameters, and the third set of parameters facilitates maintaining consistency between the control system, the optimization system, and the analysis system.

16. The computer-readable medium of claim 14, comprising instructions to:

map, using the processor, between a third set of parameters relating to a third facet of the parametric multifaceted model of the process plant, the first set of parameters, and the second set of parameters;

monitor, using the processor, operation of the process plant using the third set of parameters with a monitoring system;

wherein the first set of parameters, the second set of parameters, and the third set of parameters are each different from one another; and mapping between the first set of parameters, the second set of parameters, and the third set of parameters facilitates maintaining consistency between the control system, the optimization system, and the monitoring system.

17. The computer-readable medium of claim 16, wherein the instructions to optimize integrated operation of the process plant comprises instructions to determine produce type, production level, or both of the process plant.

* * * * *