



US010029891B1

(12) **United States Patent**
Barnett

(10) **Patent No.:** **US 10,029,891 B1**
(45) **Date of Patent:** **Jul. 24, 2018**

(54) **TRENCH ROLLER LIFTING ADAPTER**

(71) Applicant: **Ames Barnett**, Washington, GA (US)

(72) Inventor: **Ames Barnett**, Washington, GA (US)

(*) Notice: Subject to any disclaimer, the term of this patent is extended or adjusted under 35 U.S.C. 154(b) by 0 days.

(21) Appl. No.: **14/950,045**

(22) Filed: **Nov. 24, 2015**

(51) **Int. Cl.**
B66C 1/10 (2006.01)

(52) **U.S. Cl.**
CPC **B66C 1/10** (2013.01)

(58) **Field of Classification Search**
CPC B66C 1/10
USPC 294/82.1, 82.13, 82.18, 89, 215, 901;
52/125.1, 125.2, 125.4, 125.5; 404/117
See application file for complete search history.

(56) **References Cited**

U.S. PATENT DOCUMENTS

- 691,081 A * 1/1902 Stroth et al. A01B 43/00
294/82.1
- 1,368,647 A 2/1921 Myers
- 1,713,586 A * 5/1929 Wright B66D 3/06
254/404
- 2,382,718 A * 8/1945 Hickenlooper B66C 1/62
294/82.1
- 2,412,488 A * 12/1946 Austin B66C 1/10
294/81.3
- 2,842,822 A * 7/1958 Bennett F16B 45/06
24/370
- 3,001,634 A * 9/1961 Bauder B65G 9/002
104/89
- 3,167,345 A 1/1965 Dukes

- 3,194,598 A * 7/1965 Goldfuss B64D 1/22
24/599.8
- 3,827,514 A * 8/1974 Bradley B66C 1/40
177/147
- 4,173,334 A * 11/1979 Lombard B66C 1/28
294/67.1
- 4,207,693 A * 6/1980 Hemphill E02F 3/3604
37/195
- 4,371,203 A * 2/1983 Munro B66C 1/64
294/103.1
- 4,429,526 A * 2/1984 Rehbein F16G 15/06
294/82.1
- 4,810,016 A * 3/1989 Greenhow B66C 1/24
294/67.21

(Continued)

FOREIGN PATENT DOCUMENTS

- GB 2336398 10/1999
- WO 2008/118066 10/2008
- WO 2010/085155 7/2010

Primary Examiner — Paul T Chin

(74) *Attorney, Agent, or Firm* — Withers & Keys, LLC

(57) **ABSTRACT**

A trench roller lifting adapter is for inserting/removing a trench roller into/from a trench absent intervention with the trench roller within the trench by a worker and saves time required for compacting dirt in the trench. The adapter has an upper portion configured for interaction with a hook attached to a cable dangling from a crane, excavator, tractor, or other type of construction equipment used to insert/remove the trench roller into/from a trench. The upper portion has a front portion and an opposed back portion with a pin and gap extending therebetween. Each of the front and back portions include respective guide members adapted for guiding the hook toward and into engagement with the pin. The adapter also has a lower portion depending from the upper portion that is configured for secure coupling to the trench roller to be moved into or out of the trench.

10 Claims, 7 Drawing Sheets

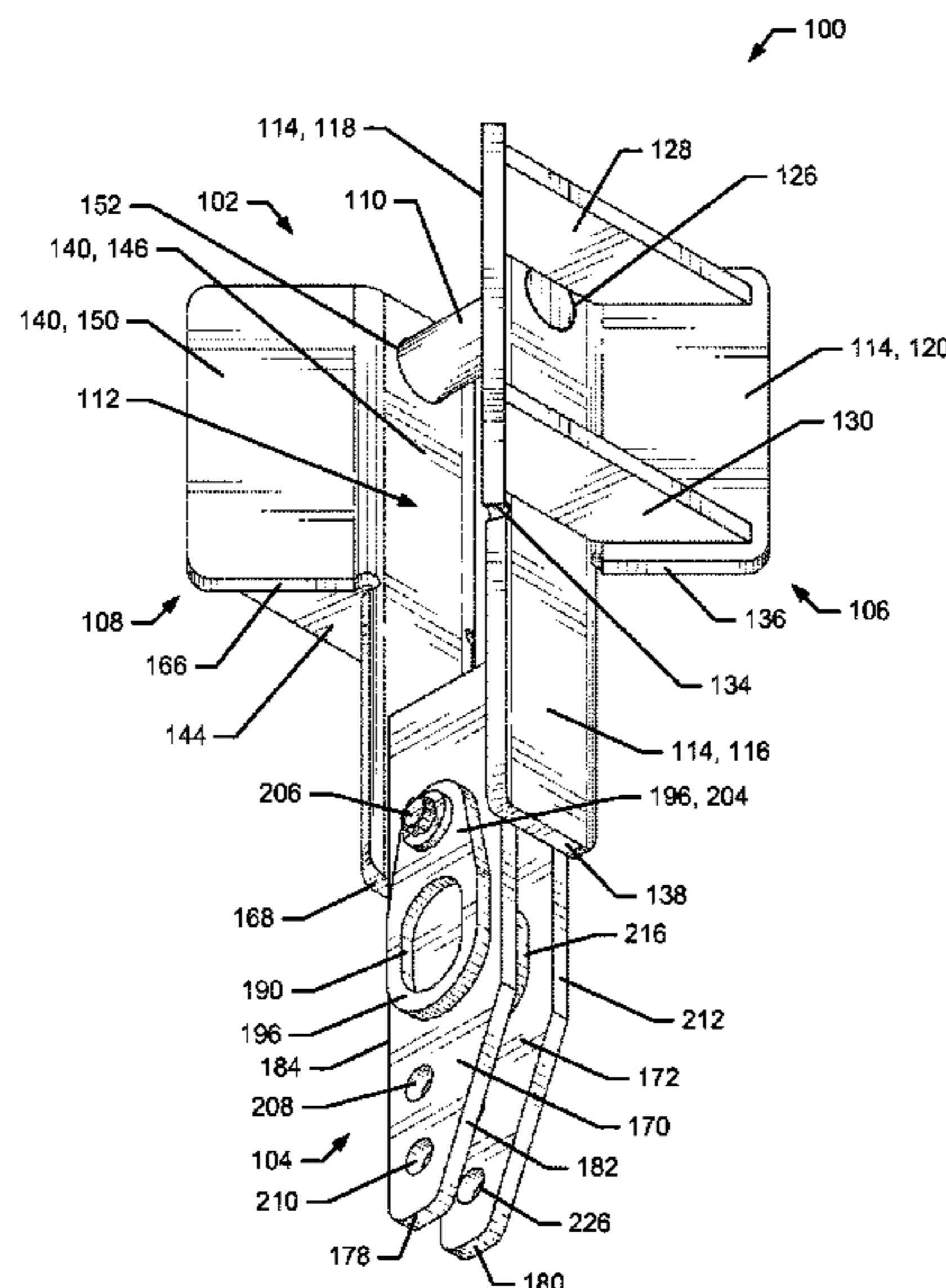

(56)

References Cited

U.S. PATENT DOCUMENTS

4,919,465 A * 4/1990 Gembarosky B66C 1/24
267/140
4,948,187 A 8/1990 Blaseck
5,037,151 A 8/1991 Rameyama et al.
5,152,567 A * 10/1992 Raber B66C 1/64
294/82.35
5,596,846 A * 1/1997 Kelly E04G 21/142
52/125.2
5,613,721 A * 3/1997 Mullins F41B 5/1465
294/217
5,735,642 A * 4/1998 Barringer B66C 1/66
294/67.1
6,089,634 A * 7/2000 Verhey B66C 1/66
294/82.35
6,581,996 B1 * 6/2003 Fromelius E04G 21/142
294/82.1
6,662,681 B2 * 12/2003 Crane E02F 3/3613
248/200
7,000,292 B2 * 2/2006 Beaudoin E05F 11/54
24/116 A
7,032,943 B1 * 4/2006 Marler B66C 1/34
294/82.31
7,506,907 B1 * 3/2009 Marler B66C 1/34
294/75
8,684,634 B2 * 4/2014 Belich E02F 3/3636
405/147
8,746,766 B2 * 6/2014 Lewkoski B66C 1/36
294/33

* cited by examiner

FIG. 2

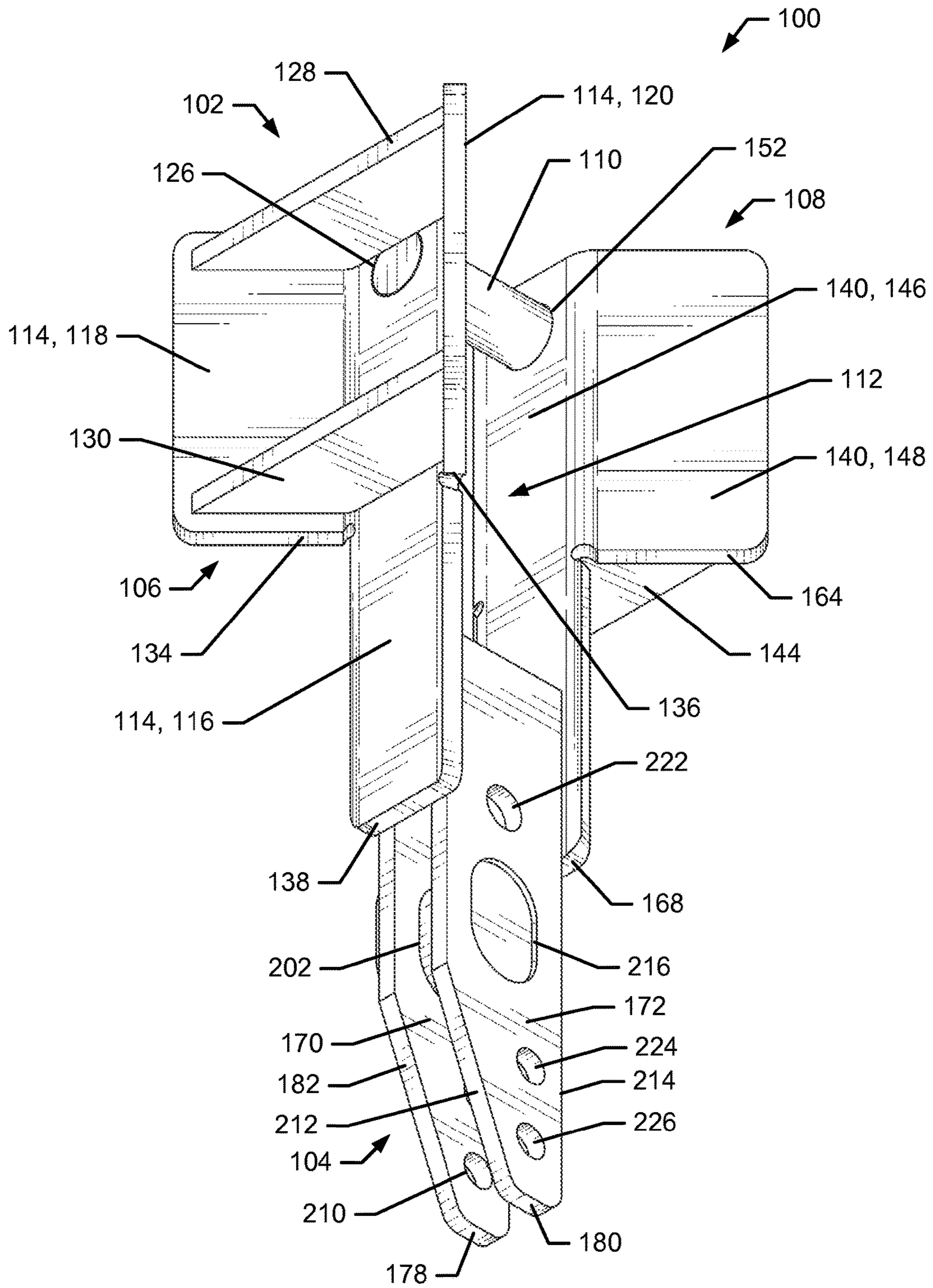

FIG. 3

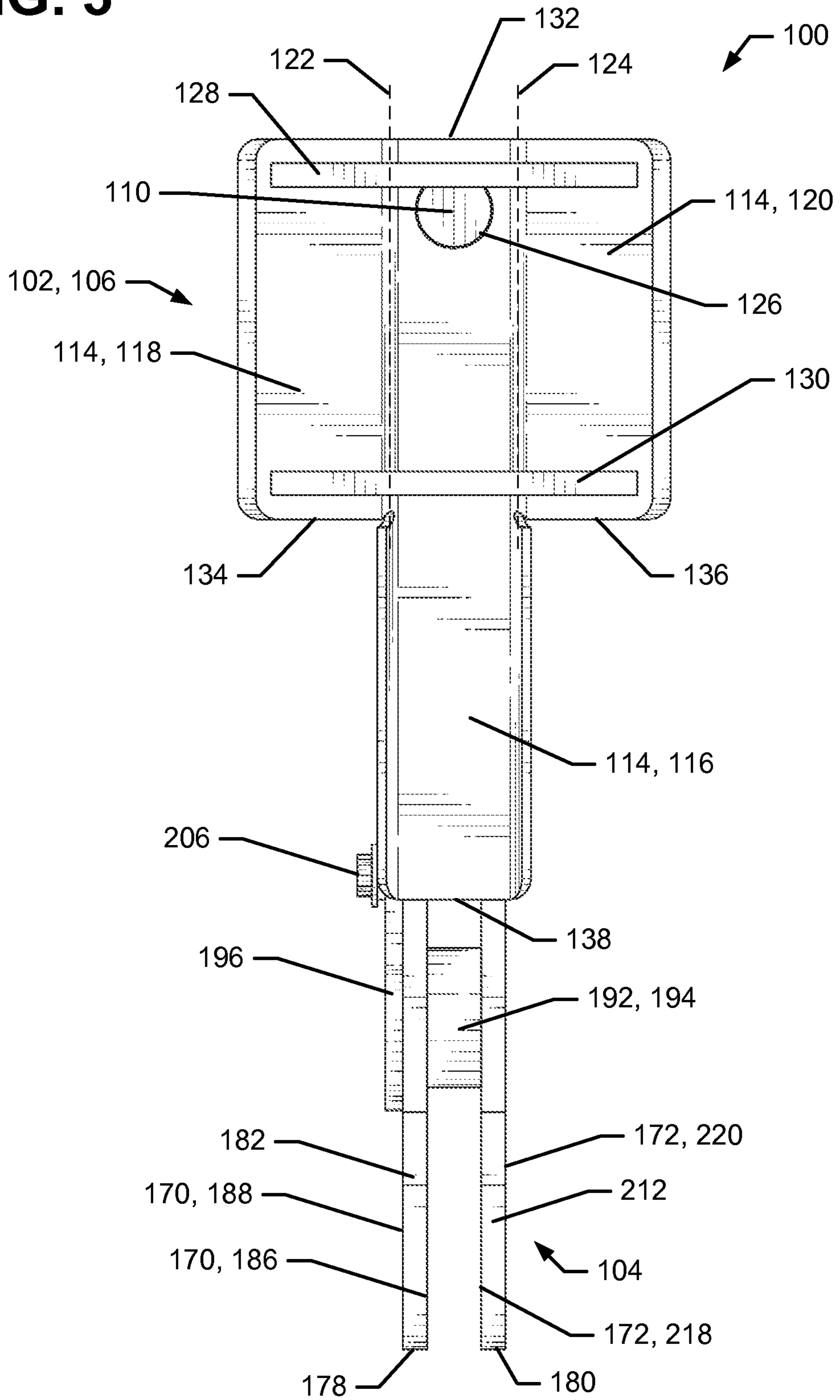

FIG. 4

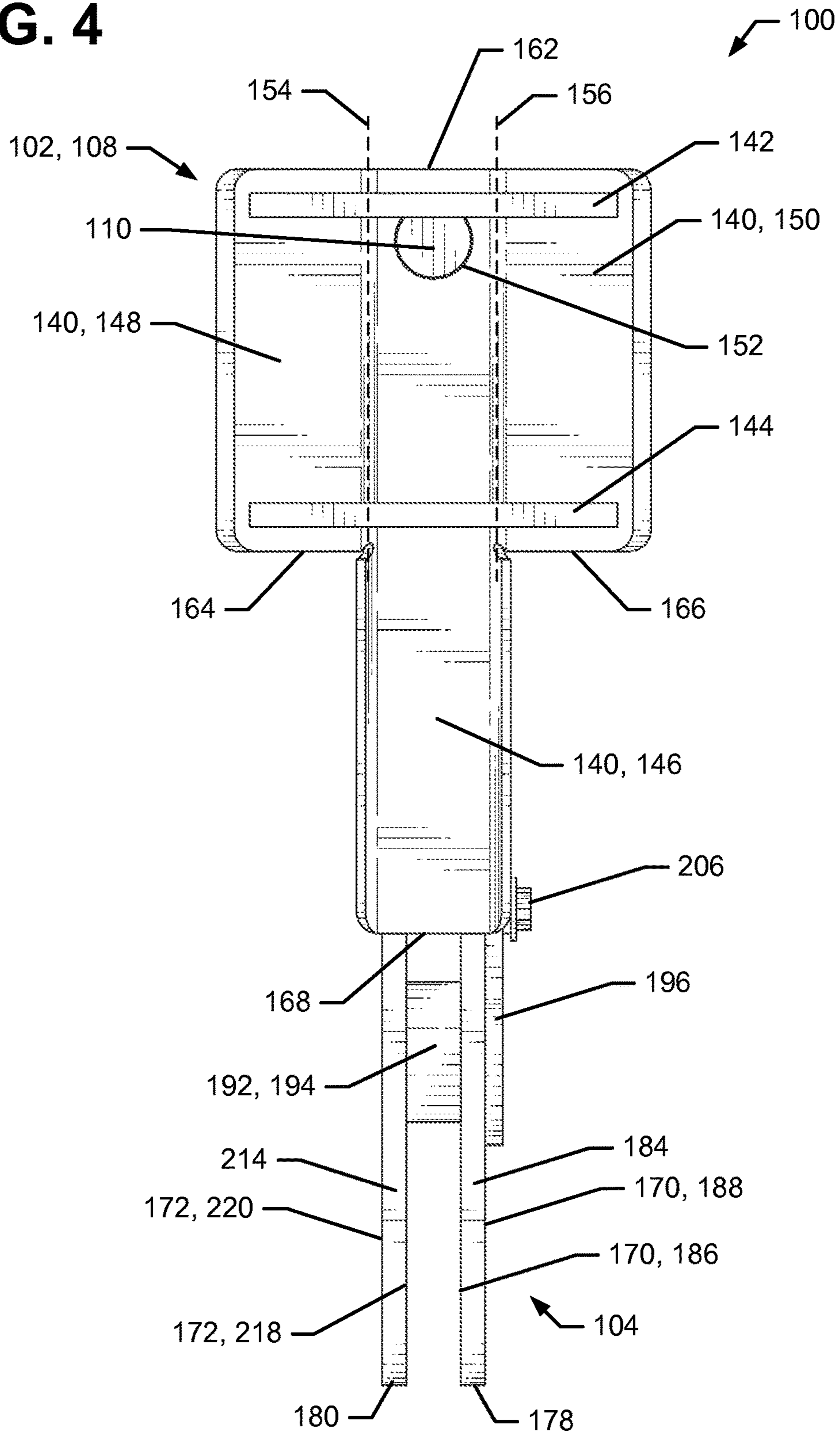

FIG. 7

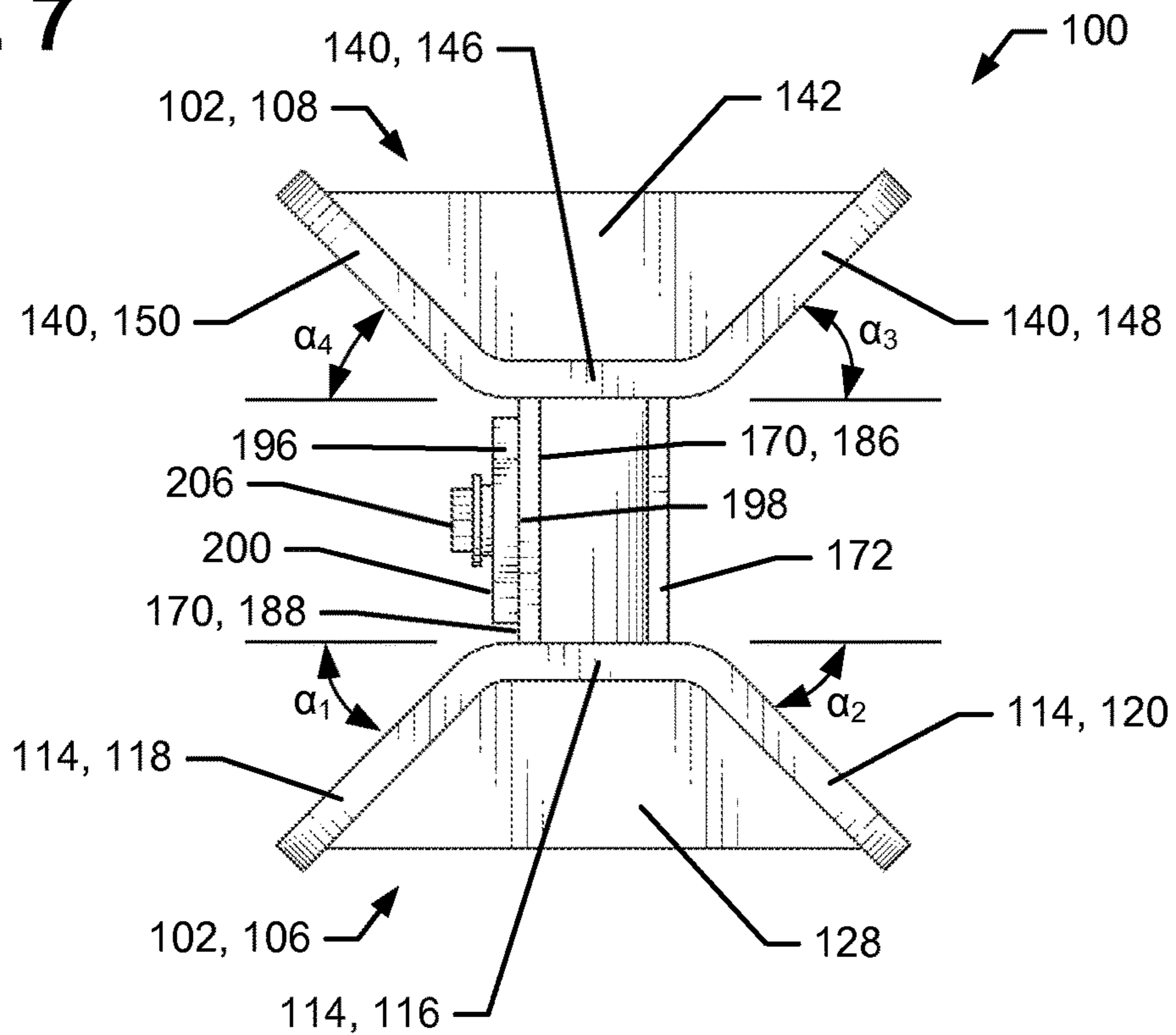
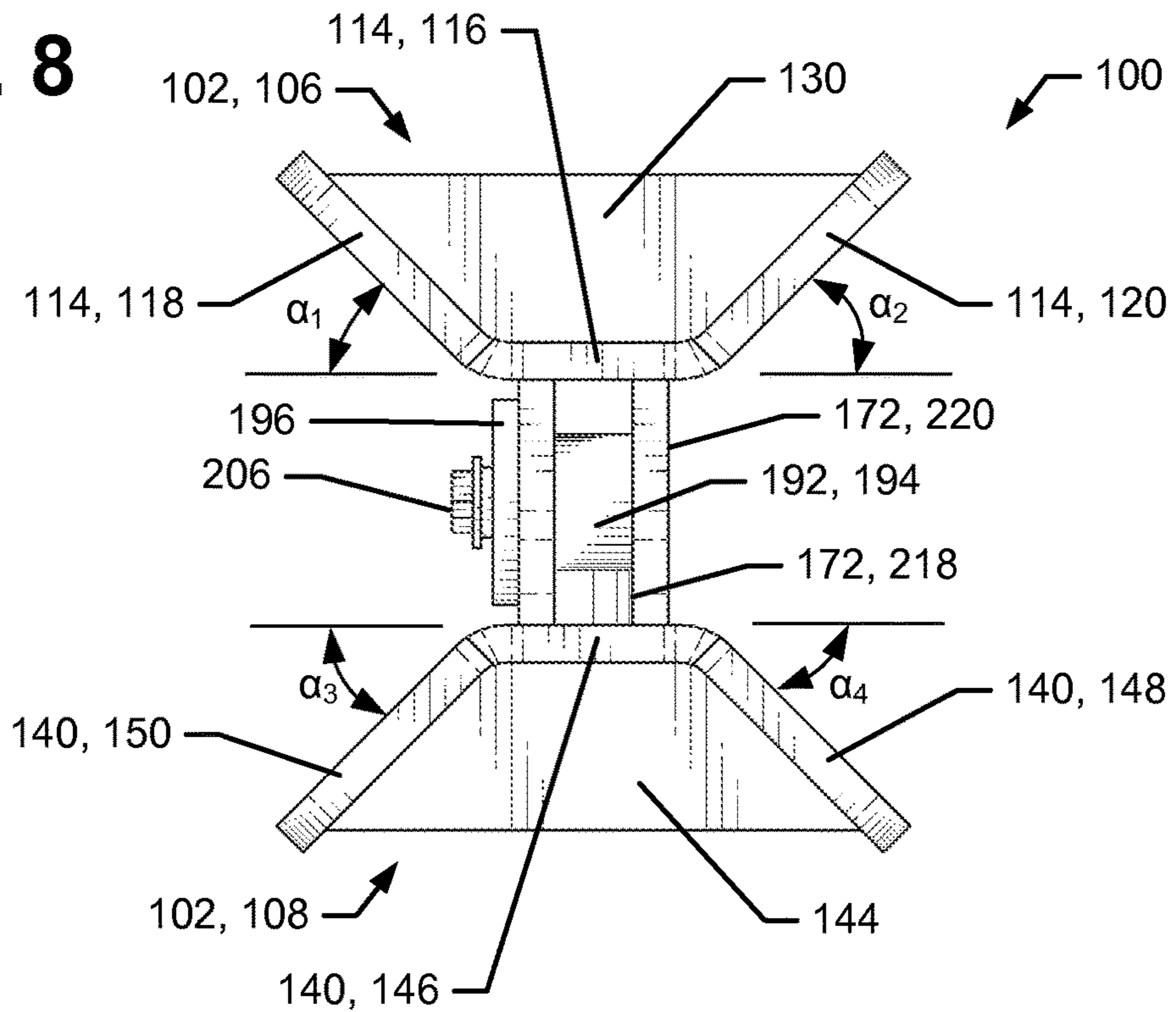

FIG. 8



1

TRENCH ROLLER LIFTING ADAPTER

FIELD OF THE INVENTION

The present invention relates, generally, to the field of construction equipment, including, but not limited to, trench rollers and apparatuses and methods for moving trench rollers into and out of trenches.

BACKGROUND OF THE INVENTION

Many construction projects require the installation of underground piping, conduit, cable, and other similar items. Typically, such installation involves the digging of a trench along a desired path using an excavator, trencher, tractor, or other construction equipment to remove dirt to form the trench and temporarily set aside the removed dirt. After the pipe, conduit, cable or other item is laid within the trench, the trench is backfilled with the removed dirt. However, to reduce adverse effects sometimes caused by the settling of the replaced dirt over time, the backfilling operation is often performed in series of sequentially repeated stages until the trench is entirely backfilled. Each stage includes the return of a portion of the previously removed dirt to the trench followed by compacting or packing of the returned dirt using a compactor or packer sometimes referred to as a "trench roller" that is designed and sized to compact or pack dirt within the trench.

In the past, construction workers had to get into the trenches in order to operate the trench rollers. Unfortunately, many construction workers were injured or killed as a result of trench cave-ins that occurred while the trench rollers were in use. To reduce the possibility of injury or death to construction workers due to trench cave-ins, today's trench rollers are remotely operated or controlled by construction workers via remote control devices such that construction workers no longer need to get into trenches to operate the trench rollers. However, trench rollers are, typically, repeatedly inserted into and removed from trenches during the stages of backfilling through the use of cables attached to the trench rollers at one end and to a crane or, frequently, the bucket of an excavator at the other end. To allow use of the trench rollers after insertion into trenches, construction workers must get into the trenches to detach the cables. And, to permit removal of the trench rollers from the trenches, construction workers must again get into the trenches to attach the cables. Because the construction workers are present within trenches during detachment and re-attachment of the cables, the construction workers are subjected to the possibility of trench cave-ins and to the corresponding possibility of injury or death resulting from such cave-ins.

Therefore, there is a need in the industry for apparatuses and methods that allow a trench roller to be inserted into, used, and removed from a trench absent intervention within the trench by a construction or other worker, and that solve these and other problems, deficiencies, and shortcomings of the present apparatuses and methods.

SUMMARY OF THE INVENTION

Broadly described, the present invention comprises an apparatus and methods for inserting a trench roller into a trench and for removing a trench roller from a trench, absent intervention within the trench by a construction or other worker. According to an example embodiment described herein, the apparatus comprises a trench roller lifting adapter having an upper portion configured for interaction with a

2

hook attached to a cable (or other lifting implement) secured to and dangling from a crane, excavator, tractor, or other type of construction equipment used to insert a trench roller into a trench or to remove a trench roller from a trench. The upper portion has a front portion and an opposed back portion with a pin and a gap extending therebetween. Each of the front and back portions include respective guide members adapted for guiding a hook dangling from a crane toward and into engagement with the pin. The trench roller lifting adapter also has a lower portion depending from the upper portion that is configured for secure coupling to a trench roller to be moved into or out of a trench. During use in accordance with a method of the present invention, the trench roller lifting adapter is connected to a trench roller before insertion of the trench roller into a trench. Then, to insert the trench roller into a trench or to remove the trench roller out of the trench, a hook connected to an excavator, tractor or other construction equipment is lowered near the lifting adapter's pin and is guided into engagement with the pin by the guiding members. After the hook engages the pin and the hook is raised, the trench roller lifting adapter and, hence, the trench roller itself are also raised and the trench roller may be moved into or out of the trench by subsequent raising or lowering of the hook. Thus, movement of the trench roller into or out of the trench is accomplished without the necessity of a human entering the trench to couple the hook to the trench roller as has been done in the past.

Advantageously, the trench roller lifting adapter allows movement of a trench roller into or out of a trench absent a human having to enter the trench, thereby substantially eliminating the possibility of injury or death of a construction worker resulting from a cave-in during movement of the trench roller into or out of the trench. Also advantageously, because the trench roller lifting adapter eliminates the need to attach and detach cables to/from a trench roller in order to lift the trench roller into or out of a trench, a significant amount of time is saved when moving the trench roller and, hence, during compaction or packing of dirt within the trench.

Other uses, advantages and benefits of the present invention may become apparent upon reading and understanding the present specification when taken in conjunction with the appended drawings.

BRIEF DESCRIPTION OF THE DRAWINGS

FIG. 1 displays a front, right side perspective view of a trench roller lifting adapter in accordance with an example embodiment of the present invention.

FIG. 2 displays a front, left side perspective view of the trench roller lifting adapter of FIG. 1.

FIG. 3 displays a front elevation view of the trench roller lifting adapter of FIG. 1.

FIG. 4 displays a back elevation view of the trench roller lifting adapter of FIG. 1.

FIG. 5 displays a left side elevation view of the trench roller lifting adapter of FIG. 1.

FIG. 6 displays a right side elevation view of the trench roller lifting adapter of FIG. 1.

FIG. 7 displays a top plan view of the trench roller lifting adapter of FIG. 1.

FIG. 8 displays a bottom plan view of the trench roller lifting adapter of FIG. 1.

DETAILED DESCRIPTION OF THE DRAWINGS

Referring now to the drawings in which like numerals represent like elements or steps throughout the several

views, FIGS. 1 and 2 display respective front right and front left side perspective views of a trench roller lifting adapter **100** in accordance with an example embodiment of the present invention. The trench roller lifting adapter **100** (also sometimes referred to herein as the “lifting adapter **100**” or “adapter **100**”) comprises an upper portion **102** and a lower portion **104** secured to and depending from the upper portion **102**. The upper portion **102** is configured for interaction with a hook attached to a cable secured to and dangling from a crane, excavator, tractor, or other type of construction equipment used to insert a trench roller into a trench or to remove a trench roller from a trench. The lower portion **104** is configured for secure coupling to a trench roller to be moved into or out of a trench. Such coupling may be permanent if, after the lifting adapter **100** is installed on a trench roller, there is no intention to move or use it with a different trench roller. Alternatively, such coupling may be non-permanent or temporary if the lifting adapter **100** is installed on a trench roller only for so long as needed to move the trench roller into and out of a trench, and is subsequently removed for use with another trench roller. It should be understood and appreciated that while the trench roller lifting adapter **100** is described herein as an individual component separable from and not a part of a trench roller, the lifting adapter **100** may be built into a trench roller as an integral and non-separable part thereof in another example embodiment. It should also be understood and appreciated that the trench roller lifting adapter **100** is further operable with a lifting implement other than a hook dangling from a crane, excavator, tractor, or other type of construction equipment to lift or lower a trench roller into or out of a trench.

The upper portion **102** of the trench roller lifting adapter **100** comprises a front portion **106**, an opposed back portion **108**, and a pin **110** extending therebetween. In accordance with the example embodiment, the front portion **106** and back portion **108** are substantially mirror images of one another. Together, the front portion **106** and back portion **108** define a gap **112** therebetween and are configured for receiving and guiding a hook (or other similar implement or device used to lift and move a trench roller) into engagement and interaction with the pin **110** absent human intervention such that the hook extends partially around and beneath the pin **110**. When so positioned during lifting and movement of a trench roller via the lifting adapter **100**, the hook exerts a force on the pin **110** sufficient to support the weight of the trench roller and to overcome the force of gravity as is necessary to lift and move the trench roller. According to the example embodiment, the pin **110** has a generally cylindrical shape and extends in a substantially horizontal direction between the lifting adapter’s front and back portions **106**, **108**.

The trench roller lifting adapter’s front portion **106** includes a guide member **114** having a generally rectangular first section **116** (as seen in the front elevation view of FIG. 3) extending predominantly in a substantially vertical direction and generally rectangular second and third sections **118**, **120** extending from the first section **116** in directions away from the first section **116** and gap **112**. More particularly, the second and third sections **118**, **120** each define respective angles, α_1 and α_2 , relative to the first section **116** (see FIGS. 7 and 8). According to the example embodiment, the angles, α_1 and α_2 , each have an angular measure of forty-five degrees (45°), but it should be understood and appreciated that the angle, α_1 and α_2 , may have a different angular measure in other example embodiments and that the second and third sections **118**, **120** may form angles, α_1 and α_2 , of different measures relative to the first section **116** in still

other example embodiments. Also according to the example embodiment, the guide member **114** is formed from a substantially planar blank with the profiles of the first, second and third sections **116**, **118**, **120** being cut from the blank, followed by bending of the second and third sections **118**, **120** relative to the first section **116** along longitudinally and vertically extending bend lines **122**, **124** to form angles α_1 and α_2 . The guide member’s first section **116** defines a hole **126** near the top thereof that is adapted to receive a part of pin **110** therein. The pin **110** is fixedly secured within hole **126** such as by welding of the pin **110** to the guide member’s first section **116** around hole **126**, but may be secured by other methods that will not permit the pin **110** to move relative to the guide member **114**.

The lifting adapter’s front portion **106** also includes a pair of vertically opposed ribs **128**, **130** fixedly secured between the guide member’s first, second and third sections **116**, **118**, **120**. The ribs **128**, **130** limit flexing and rotation of the guide member’s second and third sections **118**, **120** about bend lines **122**, **124** during use of the lifting adapter **100**. Rib **128** is configured in a substantially horizontal plane near the top edge **132** of the guide member **114**, while rib **130** is configured in a substantially horizontal plane near respective bottom edges **134**, **136** of the guide member’s second and third sections **118**, **120**. So configured and as illustrated in the front elevation view of FIG. 3, rib **130** is located approximately midway between the top and bottom edges **132**, **138** of the guide member’s first section **116** with a part of the guide member’s first portion **116** extending in a generally downward vertical direction from the location at which rib **130** is secured to the first portion **116**. According to the example embodiment, each rib **128**, **130** comprises a generally planar member having a trapezoidal shape when viewed in top plan or bottom plan view (see FIGS. 7 and 8) and is secured to and between the guide member’s first, second and third sections **116**, **118**, **120** by welding. It should be understood and appreciated that in other example embodiments, the ribs **128**, **130** may have a different shape or be configured differently and may be secured to one or more of the guide member’s first, second and third sections **116**, **118**, **120** by another method that substantially prevents movement of the second and third sections **118**, **120** about bend lines **122**, **124**.

As briefly described above, the trench roller lifting adapter **100** has a back portion **108** opposed to the front portion **106** defining gap **112** (seen most clearly in the left and right side elevation views of FIGS. 5 and 6) therebetween. The front portion **106** is positioned at a distance, A, relative to the back portion **108** such that gap **112** is configured and sized to easily receive a hook or other similar device between the front and back portions **106**, **108** and to do so without requiring a human to guide the hook or device into the gap **112**. The pin **110** extends through the gap **112** in a generally front-to-back horizontal direction.

The back portion **108** of lifting adapter’s upper portion **102**, as also briefly described above, is substantially a mirror image of the front portion **106**. As such, the trench roller lifting adapter’s back portion **108** includes a guide member **140** and a pair of vertically opposed ribs **142**, **144** substantially similar to the guide member **114** and ribs **128**, **130** of the front portion **106**. Guide member **140** has first, second and third sections **146**, **148**, **150** with the first section **146** having a generally rectangular shape when viewed in the back elevation view of FIG. 4. The first section **146** extends predominantly in a substantially vertical direction and defines a hole **152** near the top thereof that is adapted to receive a part of pin **110** fixedly secured therein such as by

5

welding of the pin 110 to the guide member's first section 146 around hole 152. It should be understood and appreciated that pin 110 may be secured within hole 152 by other methods that will not permit the pin 110 to move relative to the guide member 140.

The second and third sections 148, 150 of guide member 140 have a generally rectangular shape when viewed normal thereto and extend from the first section 146 in directions away from the first section 146 and gap 112. Similar to the first, second and third sections 116, 118, 120 of guide member 114, the second and third sections 148, 150 of guide member 140 each define respective angles, α_3 and α_4 , relative to the first section 146 (see FIGS. 7 and 8). In accordance with the example embodiment, each of the angles, α_3 and α_4 , has an angular measure of forty-five degrees (45°). However, it should be understood and appreciated that each angle, α_3 and α_4 , may have a different angular measure in other example embodiments and that the second and third sections 148, 150 may form angles, α_3 and α_4 , of different measures relative to the first section 146 in still other example embodiments. Also, in accordance with the example embodiment and similar to guide member 114, the guide member 140 is formed from a substantially planar blank with the profiles of the first, second and third sections 146, 148, 150 being cut from the blank and with the second and third sections 148, 150 being bent relative to the first section 146 along longitudinally and vertically extending bend lines 154, 156 to form angles α_3 and α_4 .

Again similar to the lifting adapter's front portion 106, the pair of vertically opposed ribs 142, 144 of the back portion 108 of the lifting adapter's upper portion 102 are fixedly secured between the first, second and third sections 146, 148, 150 of guide member 140. Ribs 142, 144 restrict flexing and rotation of the guide member's second and third sections 148, 150 about bend lines 154, 156 during use of the lifting adapter 100. Rib 142 is configured in a substantially horizontal plane near the top edge 162 of the guide member 140, while rib 144 is configured in a substantially horizontal plane near respective bottom edges 164, 166 of the guide member's second and third sections 148, 150. Seen in the back elevation view of FIG. 4, rib 144 is located generally at the midpoint between the top and bottom edges 162, 168 of the guide member's first section 146 such that a part of the guide member's first section 146 extends in a generally downward vertical direction from the location at which rib 144 is secured to the first portion 146. Similar to ribs 128, 130, each rib 142, 144 comprises a generally planar member having a trapezoidal shape when viewed in top plan or bottom plan view (see FIGS. 7 and 8) and is secured to and between the guide member's first, second and third sections 146, 148, 150 by welding. It should be understood and appreciated that in other example embodiments, the ribs 142, 144 may have a different shape or be configured differently and may be secured to one or more of the guide member's first, second and third sections 146, 148, 150 by another method that substantially prevents movement of the second and third sections 148, 150 about bend lines 154, 156.

The lower portion 104 of the trench roller lifting adapter 100, as described above, depends from the lifting adapter's upper portion 102 and is connectable to a trench roller so that, in use, the entire lifting adapter 100 extends predominantly in an upward vertical direction from the trench roller with the upper portion 102 being visible and generally accessible from above the trench roller and the lower portion 104 being less visible and generally less accessible from above the trench roller. The lower portion 104 comprises a

6

right leg 170 and an opposed left leg 172 extending downward in a generally vertical direction and partially between and perpendicular to the first sections 116, 146 of guide members 114, 140 of the lifting adapter's upper portion 102.

As seen in FIGS. 5 and 6, the right and left legs 170, 172 have respective first ends 174, 176 and distant second ends 178, 180. The right and left legs 170, 172 are positioned with their first ends 174, 176 at a vertical distance, B, from pin 110. The first ends 174, 176 of the right and left legs 170, 172 define the usable lower extent of the gap 112. According to the example embodiment, the distance, B, is selected to make gap 112 sufficiently large in the vertical direction to easily receive a hook or other similar device and to permit such hook or device to move in and out of the gap 112 beneath pin 110 and between the opposed first sections 116, 146 of guide members 114, 140 absent human intervention.

The right leg 170 comprises a substantially planar member extending predominantly in the vertical longitudinal direction between first and second ends 174, 178. The right leg 170 has a front edge 182 and back edge 184, each extending between the leg's first end 174 and second end 178. The first end 174 of right leg 170 is positioned between the first sections 116, 146 of the guide members 114, 140 such that a portion of the leg's front edge 182 is in contact with and fixedly secured to the first section 116 of guide member 114 and a portion of the leg's back edge 184 is in contact with and fixedly secured to the first section 146 of guide member 140. The portions of the leg's front and back edges 182, 184 are, according to the example embodiment and respectively, fixedly secured to guide members 114, 140 by welding. However, it should be understood and appreciated that in other example embodiments, the portions of the leg's front and back edges 182, 184 may be fixedly secured, respectively, to the first sections 116, 146 of guide members 114, 140 by a method that rigidly attaches the right leg 170 to the guide members 114, 140 and that provides sufficient strength for the lifting adapter 100 to used in moving a trench roller into and out of a trench.

As seen in FIG. 6, the lower portion of the right leg's front edge 182 (nearest the leg's second end 178) defines an angle, β , relative to the upper portion of the right leg's front edge 182 (nearest the leg's first end 176) such that the right leg 170 tapers front-to-back and is narrower at the leg's second end 178 than at the leg's first end 176. The measure of angle, β , is selected in conjunction with the dimensions of the right leg 170 so as to provide tapering of the right leg 170 sufficient to enable greater ease of connection and disconnection of the trench roller lifting adapter 100 to/from a trench roller. The angle, β , has a measure of thirty degrees (30°) according to the example embodiment, but it should be understood and appreciated that the angle, β , may have other measures in other example embodiments with angle, β , most likely having a measure in the range of fifteen degrees (15°) to seventy-five degrees (75°).

The right leg 170 has inboard and outboard surfaces 186, 188 (see FIGS. 7 and 8) and defines a bore 190 for receiving a pin 192 therein to releasably couple the trench roller lifting adapter 100 to a trench roller. The bore 190 extends through the right leg 170 and between the inboard and outboard surfaces 186, 188. The pin 192 has a shank 194 and a flange 196 fixedly secured to and about an end of the shank 194. The pin's shank 194 and bore 190 are cooperatively shaped and sized so as to permit the pin's shank 194 to be snugly received within the bore 190, yet be slidable into and out of the bore 190 in a lateral direction generally perpendicular to inboard and outboard surfaces 186, 188 during attachment and detachment of the trench roller lifting adapter 100

to/from a trench roller. The pin's shank **194** is also shaped and sized to withstand shear and other forces acting on the pin's shank **194** during use of the trench roller lifting adapter **100**. According to the example embodiment and as viewed in the right side elevation view of FIG. 6, the bore **190** and pin's shank **194** have a stadium or discorectangle cross-sectional shape with their long cross-sectional axes being substantially parallel to the vertical longitudinal direction. It should be understood and appreciated that the bore **190** and pin's shank **194** may have other shapes, sizes and configurations in other example embodiments.

The pin's flange **196** has an inboard surface **198** and opposed outboard surface **200**, and defines a bore **202** extending between the inboard and outboard surfaces **198**, **200**. The bore **202** is cooperatively shaped and sized with the pin's shank **194** and receives an end of the pin's shank **194** therein. The pin's flange **196** and shank **194** are fixedly secured to one another such as by welding or other method suitable for permanently connecting the flange **196** and shank **194**. The flange **196** has a lobe portion **204** and defines a hole (not visible) in such lobe portion **204** extending between the pin's inboard and outboard surfaces **198**, **200**. The hole in the lobe portion **204** aligns coaxially with a hole (not visible) extending between the leg's inboard and outboard surfaces **186**, **188**. A fastener **206** extends into the holes and releasably secures the pin **192** to the right leg **170** of the lifting adapter's lower portion **104** with the flange's inboard surface **198** in contact with the leg's outboard surface **188** and the pin's shank **194** within the leg's bore **190**.

The right leg **170** additionally defines a pair of vertically-disposed holes **208**, **210** near the leg's second end **178** extending through the right leg **170** between the leg's inboard and outboard surfaces **186**, **188**. The holes **208**, **210** are configured to receive fasteners extending therethrough when the trench roller lifting adapter **100** is attached to a trench roller to further secure the lifting adapter **100** to the trench roller.

As briefly described above, the lower portion **104** of the trench roller lifting adapter **100** includes a left leg **172** having a first end **176** and a distant second end **180**. The left leg **172** is substantially similar to the right leg **170** and comprises a substantially planar member extending predominantly in the vertical longitudinal direction between the leg's ends **176**, **180** and generally parallel to the right leg **170**. A front edge **212** and back edge **214** extend between the left leg's first and second ends **176**, **180**. The left leg's first end **176** is positioned between the first sections **116**, **146** of the guide members **114**, **140** with a portion of the leg's front edge **212** in contact with and fixedly secured to the first section **116** of guide member **114** and a portion of the leg's back edge **214** in contact with and fixedly secured to the first section **146** of guide member **140**. In accordance with the example embodiment, the portions of the leg's front and back edges **212**, **214** are fixedly secured by welding to guide members **114**, **140**. It should, however, be understood and appreciated that such portions of the leg's front and back edges **212**, **214** may be fixedly secured, respectively, to the first sections **116**, **146** of guide members **114**, **140** by a method that rigidly attaches the left leg **172** to the guide members **114**, **140** and that provides sufficient strength for the lifting adapter **100** to be used in moving a trench roller into and out of a trench.

Similar to the right leg **170** and as seen in FIG. 5, the left leg **172** tapers from front-to-back near the leg's second end **180** and is narrower at the leg's second end **180** than at the leg's first end **176**. So that the left leg **172** is generally a

mirror image of the right leg **170**, the lower portion of the left leg's front edge **212** (nearest the leg's second end **180**) defines an angle, Θ , relative to the upper portion of the left leg's front edge **212** (nearest the leg's first end **176**) that has a measure equal to the angle, β , described above with respect to the right leg **170**. The tapering of the left leg **172**, like the tapering of the right leg **170**, enables greater ease of connection and disconnection of the trench roller lifting adapter **100** to/from a trench roller.

The left leg **172** defines a bore **216** extending there-through between inboard and outboard surfaces **218**, **220** (see FIGS. 7 and 8). The bore **216** is coaxially aligned with bore **190** of the first leg **170** and is configured to match the size and shape of bore **190** such that bore **216** is adapted to snugly receive the shank **194** of pin **192** therein and to allow the shank **194** to slide into and out of the bore **216** in a lateral direction generally perpendicular to inboard and outboard surfaces **218**, **220** during attachment and detachment of the trench roller lifting adapter **100** to/from a trench roller. The left leg **172** also defines a hole **222** extending between the leg's inboard and outboard surfaces **218**, **220** for receiving a fastener in the event the pin's shank **194** is alternatively inserted through bores **190**, **216** with the pin's flange **196** in contact with the outboard surface **220** of the left leg **172**.

Additionally and similar to the right leg **170**, the left leg **172** defines a pair of vertically-disposed holes **224**, **226** near the leg's second end **180** extending through the left leg **172** between the leg's inboard and outboard surfaces **212**, **214**. The holes **224**, **226** are coaxially aligned with holes **208**, **210** of the right leg **170** and are configured to receive fasteners extending therethrough when the trench roller lifting adapter **100** is attached to a trench roller to further secure the lifting adapter **100** to the trench roller.

Together, the right and left legs **170**, **172** of the lifting adapter's lower portion **104** form a fork-like or clevis-like structure for receiving a tang-like portion of a trench roller therebetween. The tang-like portion defines a bore configured similarly to bores **190**, **216** such that when the tang-like portion is present between the lifting adapter's right and left legs **170**, **172** during use, the shank **194** of pin **192** extends through the bore in the tang-like portion and through the bores **190**, **216** of the legs **170**, **172**. Acting similarly to a clevis pin and in conjunction with fasteners secured through holes **208**, **210** of the right leg **170** and holes **224**, **226** of the left leg **172**, the pin **192** couples the tang-like portion of the trench roller (and, hence, the trench roller) to the trench roller lifting adapter **100**. Once so coupled, the trench roller may be lifted into or out of a trench through use of the trench roller lifting adapter **100** and without requiring a human to enter the trench to connect the trench roller for lifting and movement.

During use, the trench roller lifting adapter **100** is secured to a trench roller by positioning the lifting adapter **100** relative to the trench roller with a cooperative tang-like portion of the trench roller received between the right and left legs **170**, **172** of the lifting adapter's lower portion **104**. Then, the shank **194** of pin **192** is inserted into and received through bore **190** of leg **170**, through the bore in the tang-like portion, and through the bore **216** of leg **172**. Fasteners are next inserted into and received through holes **208**, **210** of the right leg **170** and holes **224**, **226** of the left leg **172**. With pin **192** securely held in position, the tang-like portion of the trench roller (and, hence, the trench roller) is releasably coupled to the trench roller lifting adapter **100**.

To lift the trench roller, whether into or out of a trench, a hook dangling from an excavator, tractor or other type of construction equipment is positioned near the upper portion

102 of the trench roller lifting adapter 100. The hook is moved toward pin 110 at an elevation slightly below the elevation of the pin 110 by the equipment operator. Typically, the hook moves around in a somewhat uncontrollable manner while being moved in a direction predominantly toward pin 110 and may strike the second sections 118, 148 of guide members 114, 140 or the third sections of 120, 150 of guide members 114, 140. Because the second sections 118, 148 of guide members 114, 140 and the third sections of 120, 150 of guide members 114, 140 are angled relative to the first sections 116, 146 of guide members 114, 140, the hook is directed and guided by the guide members 114, 140 into gap 112 as the hook moves toward pin 110. Upon further movement of the hook toward pin 110, the hook contacts pin 110 and through a slight movement of the hook in the upward vertical direction, the hook engages pin 110. In response to further movement in the upward vertical direction, the hook exerts a force on pin 110 causing pin 110 and, hence, the lifting adapter 100 and trench roller to be moved in the upward vertical direction. With the lifting adapter 100 and trench roller suspended from the hook, the lifting adapter 100 and trench roller may be moved into or out of a trench, as the case may be.

After movement of the trench roller into or out of the trench and to render the trench roller ready for subsequent use or movement, the hook is disengaged from the trench roller. To do so, the hook is moved by the equipment operator in a generally downward vertical direction to disengage the hook from pin 110. Further movement of the hook by the equipment operator in a direction generally away from pin 110 moves the hook out of gap 112 and away from the trench roller lifting adapter 100. The trench roller is then ready for use or additional movement, such as away from the trench to another area of the construction site or onto a flatbed truck or trailer for movement elsewhere.

Whereas the present invention has been described in detail above with respect to an example embodiment thereof, it should be appreciated that variations and modifications might be effected within the spirit and scope of the present invention.

What is claimed is:

1. An apparatus for use in lifting a trench roller into or out of a trench, said apparatus comprising:

a first portion adapted for connection to a trench roller; and

a second portion extending from said first portion and adapted for interaction with a hook of an implement used to lift the trench roller,

wherein the second portion comprises a first guide member and an opposed second guide member defining a gap therebetween, the first guide member and the second guide member being configured to direct the implement into the gap, and

wherein the first guide member has a section and the second guide member has a section opposed to the section of the first guide member, and wherein the section of the first guide member has multiple surfaces and includes a first planar surface having a largest surface area of the section of the first guide member and wherein the section of the second guide member includes multiple surfaces and has a first planar surface having a largest surface area of the section of the second guide member, wherein a plane defined by the first planar surface of the section of the first guide member and a plane defined by the first planar surface of the section of the second guide member form an angle therebetween.

2. The apparatus of claim 1, wherein the second portion further comprises a pin extending within the gap between the first guide member and the second guide member.

3. The apparatus of claim 2, wherein the pin is adapted to be received at least partially by the hook.

4. The apparatus of claim 2, wherein the first guide member and second guide member are further configured to direct at least part of the hook under the pin.

5. The apparatus of claim 1, wherein the first portion has a clevis configured to receive a tang protruding from the trench roller for secure connection of the first portion to the trench roller.

6. An apparatus for use in lifting a trench roller into or out of a trench, the apparatus comprising:

an upper portion adapted for connection with an implement for lifting the trench roller; and

a lower portion depending from the upper portion, the lower portion comprising at least one leg extending from the upper portion and a pin extending perpendicular to a longitudinal direction of the leg with the pin being configured for coupling to the trench roller,

wherein the upper portion comprises a pin for connection with the implement,

wherein the upper portion is configured to guide the implement toward the pin during connection of the upper portion and the implement, and

wherein the upper portion comprises a first section and a second section for guiding the implement toward the pin, wherein the first section has multiple surfaces and includes a first planar surface having a largest surface area of the first section, wherein the second section has multiple surfaces and includes a first planar surface having a largest surface area of the second section, wherein the first section and the second section extend away from the pin, and wherein the first planar surface of the first section diverges from the first planar surface of the second section while extending away from the pin.

7. The apparatus of claim 6, wherein the upper portion comprises a third section and a fourth section for guiding the implement toward the pin, wherein the third section and the fourth section extend away from the pin, and wherein the third section diverges from the fourth section while extending away from the pin.

8. The apparatus of claim 7, wherein the first section and the second section extend away from the pin generally in a first lateral direction, and wherein the third section and the fourth section extend away from the pin generally in a second lateral direction.

9. The apparatus of claim 6, wherein the lower portion comprises a first leg and a second extending from the upper portion to form a clevis configured to receive a tang protruding from the trench roller for secure connection of the first portion to the trench roller and wherein the pin is configured to pass through a bore of the tang.

10. An apparatus for use in lifting a trench roller into or out of a trench, the apparatus comprising:

a first guide member for directing an implement used to lift the trench roller;

a second guide member for directing the implement, the second guide member being positioned opposed to the first guide member;

a pin extending between the first guide member and the second guide member, the pin being adapted for interaction with the implement such that the first guide member and the second guide member direct the implement to the pin; and

a portion configured for coupling to the trench roller, the portion being connected to at least one of the first guide member or the second guide member,
wherein the first guide member and the second guide member define a gap therebetween, and wherein the first guide member and the second guide member are nearest together in the vicinity of the pin, and
wherein the first guide member comprises a section and the second guide member comprises a section for guiding the implement toward the pin, wherein the section of the first guide member has multiple surfaces and includes a first planar surface having a largest surface area of the section of the first guide member, wherein the section of the second guide member has multiple surfaces and includes a first planar surface having a largest surface area of the section of the second guide member, wherein the section of the first guide member and the section of the second guide member extend away from the pin, and wherein the first planar surface of the section of the first guide member diverges from the first planar surface of the section of the second guide member while extending away from the pin.

* * * * *