



US010029818B2

(12) **United States Patent**
Kelly et al.

(10) **Patent No.:** **US 10,029,818 B2**
(45) **Date of Patent:** **Jul. 24, 2018**

(54) **METHOD OF PACKAGING A FREE
STANDING MACHINE USING A
MULTI-COMPONENT BASE STRUCTURE**

(71) Applicant: **Daniel Kelly**, Medford, NJ (US)

(72) Inventors: **Daniel Kelly**, Medford, NJ (US); **John
A. Spadavecchia**, Red House, VA (US);
James Favaron, Columbia, SC (US)

(73) Assignee: **Daniel Kelly**, Medford, NJ (US)

(*) Notice: Subject to any disclaimer, the term of this
patent is extended or adjusted under 35
U.S.C. 154(b) by 440 days.

(21) Appl. No.: **14/946,152**

(22) Filed: **Nov. 19, 2015**

(65) **Prior Publication Data**

US 2016/0075457 A1 Mar. 17, 2016

(51) **Int. Cl.**

B65B 25/00 (2006.01)
B65D 85/64 (2006.01)
B65D 85/68 (2006.01)
B65D 19/00 (2006.01)
B65D 19/06 (2006.01)
B65D 19/44 (2006.01)

(52) **U.S. Cl.**

CPC **B65D 19/0004** (2013.01); **B65B 25/00**
(2013.01); **B65D 19/0067** (2013.01);
(Continued)

(58) **Field of Classification Search**

CPC B65B 25/00; B65B 27/00; B65D 19/0004;
B65D 19/0053; B65D 19/0055; B65D
19/0057; B65D 19/0059; B65D 19/0067;
B65D 19/0071; B65D 19/0073; B65D
19/0075; B65D 19/06; B65D 19/44;
(Continued)

(56) **References Cited**

U.S. PATENT DOCUMENTS

1,333,658 A * 3/1920 Huseby B65D 85/64
217/53
2,321,063 A * 6/1943 Bohnke B65D 85/64
206/320

(Continued)

FOREIGN PATENT DOCUMENTS

DE 2258097 A1 * 5/1974 B65D 61/00
EP 0457118 A1 11/1991

(Continued)

OTHER PUBLICATIONS

International Search Report and Written Opinion dated Sep. 2, 2013
in connection with International Application No. PCT/US2013/
048503 (10 pages).

Primary Examiner — Stephen F Gerrity

(74) *Attorney, Agent, or Firm* — Massina Pat & TM Law

(57) **ABSTRACT**

A pallet base structure including a center deck defining a
support surface extending between opposed sides and hav-
ing at least two lugs extending from each of the opposed
sides. A pair of base side members are positioned along
respective sides of the center deck. Each base side member
has first and second spaced apart base legs and a support
member extending between the base legs with at least two
corresponding lug receiving slots defined in the support
member. The respective lugs are received in the respective
lug receiving slots such that the center deck support surface
is aligned with an upper surface of each support member to
define a planar pallet surface. A packaging system incorpo-
rating the pallet base structure is also described.

4 Claims, 14 Drawing Sheets

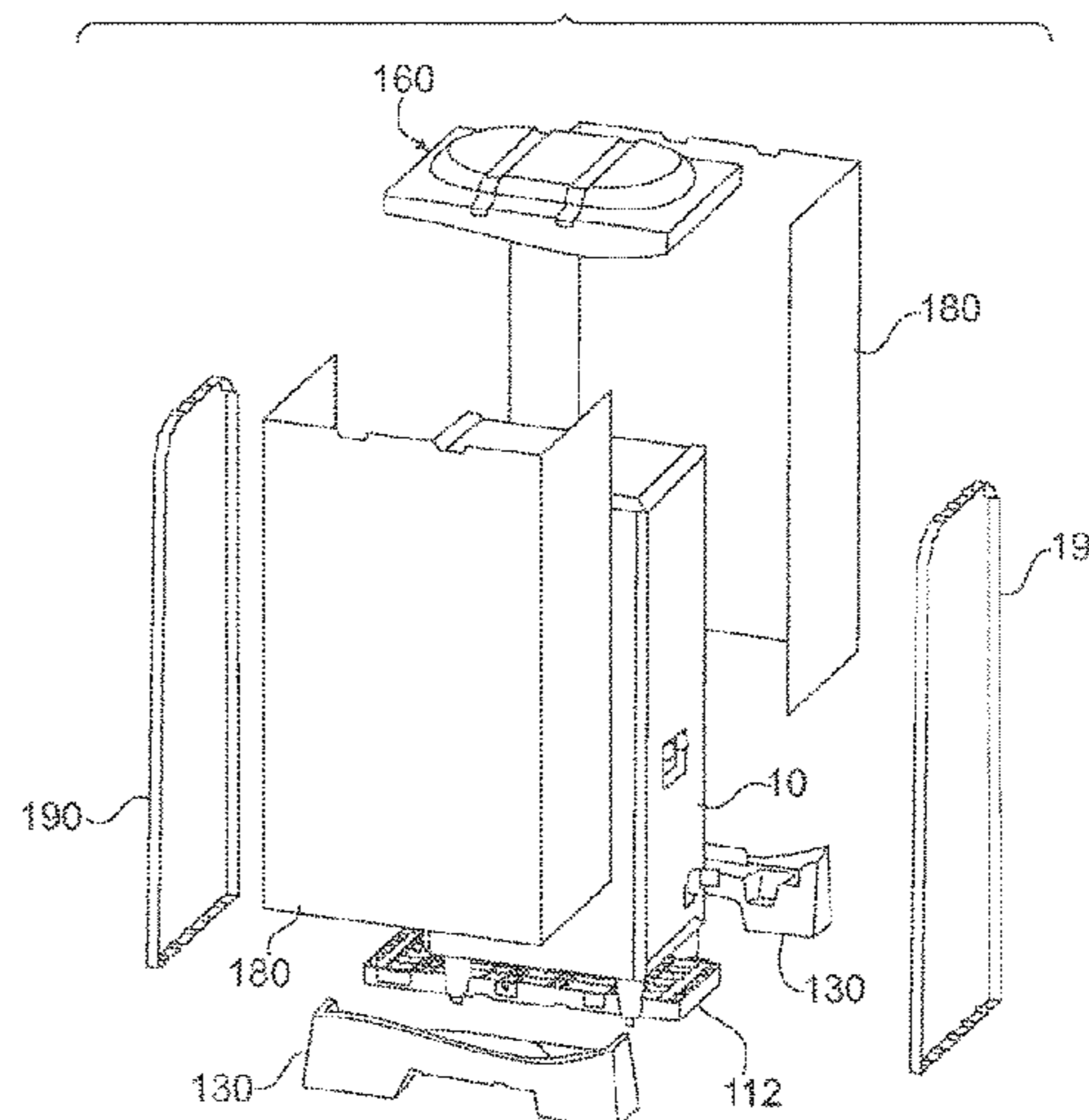
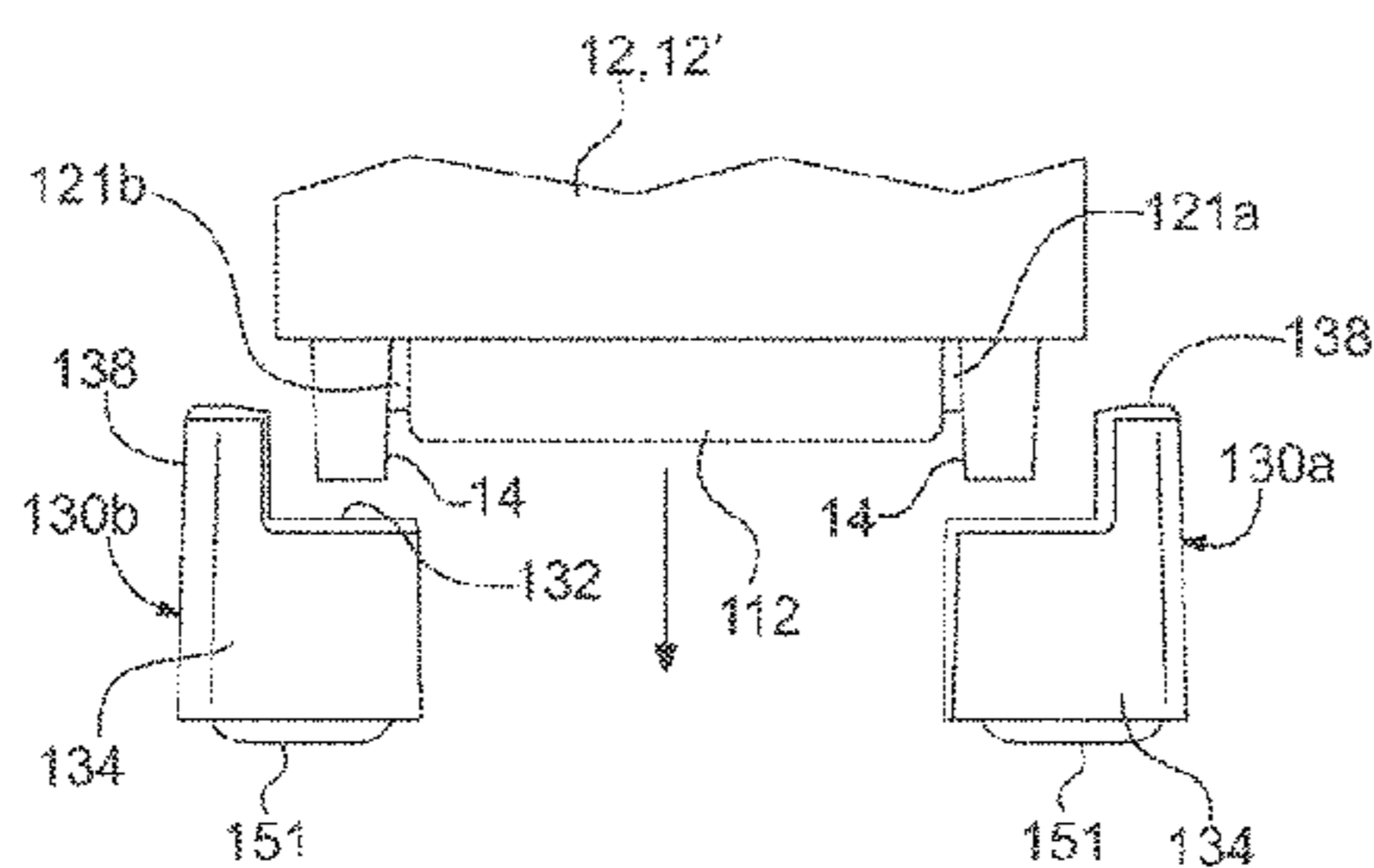

(52) **U.S. Cl.**
 CPC **B65D 19/06** (2013.01); **B65D 19/44**
 (2013.01); **B65D 85/64** (2013.01); **B65D**
85/68 (2013.01); **B65D 2519/00034** (2013.01);
B65D 2519/00273 (2013.01); **B65D**
2519/00288 (2013.01); **B65D 2519/00293**
 (2013.01); **B65D 2519/00308** (2013.01); **B65D**
2519/00323 (2013.01); **B65D 2519/00333**
 (2013.01); **B65D 2519/00497** (2013.01); **B65D**
2519/00567 (2013.01); **B65D 2519/00621**
 (2013.01); **B65D 2519/00661** (2013.01); **B65D**
2519/00711 (2013.01)

(58) **Field of Classification Search**
 CPC B65D 85/64; B65D 85/68; B65D
 2519/00034; B65D 2519/00273; B65D
 2519/00288; B65D 2519/00293; B65D
 2519/00308; B65D 2519/00323; B65D
 2519/00333; B65D 2519/00497; B65D
 2519/00557; B65D 2519/00567; B65D
 2519/00621; B65D 2519/00661; B65D
 2519/00711; B65D 2519/0081; B65D
 2519/00815; B65D 2585/64; B65D
 2585/68; B65D 2585/6897
 USPC 53/399, 449, 176, 580, 582; 108/51.11,
 108/56.3; 206/320, 597, 599
 See application file for complete search history.

(56) **References Cited**
 U.S. PATENT DOCUMENTS

3,253,379 A * 5/1966 Foradora B65B 11/585
 53/399
 3,471,116 A * 10/1969 De Cherrie B65D 19/00
 206/320

3,661,318 A * 5/1972 Miller et al. B65D 5/5035
 206/320
 4,811,840 A * 3/1989 Muyskens B65D 85/68
 206/320
 4,969,307 A * 11/1990 Winans et al. B65D 19/44
 53/399
 5,249,678 A * 10/1993 Traina B65D 85/64
 206/320
 5,911,179 A * 6/1999 Spiczka B65D 19/44
 108/51.11
 6,286,805 B1 * 9/2001 Bunn et al. F16F 15/0232
 108/57.12
 6,357,587 B1 * 3/2002 Melms, Jr. B65D 85/64
 206/320
 7,219,609 B1 * 5/2007 Utz et al. B65D 19/44
 108/55.3
 8,061,521 B1 * 11/2011 Lowry et al. B65D 19/44
 206/576
 2004/0000259 A1 * 1/2004 Taft B65D 19/0073
 108/57.25
 2007/0131147 A1 6/2007 Brubaker et al.
 2007/0256614 A1 * 11/2007 Chen B65D 19/0069
 108/153.1

FOREIGN PATENT DOCUMENTS

JP 03187868 A * 8/1991
 JP 05338689 A * 12/1993
 JP 06115564 A * 4/1994
 JP 2002-053194 A 2/2002
 JP 2011-255927 A 12/2011
 KP 10-1999-0039123 6/1999

* cited by examiner

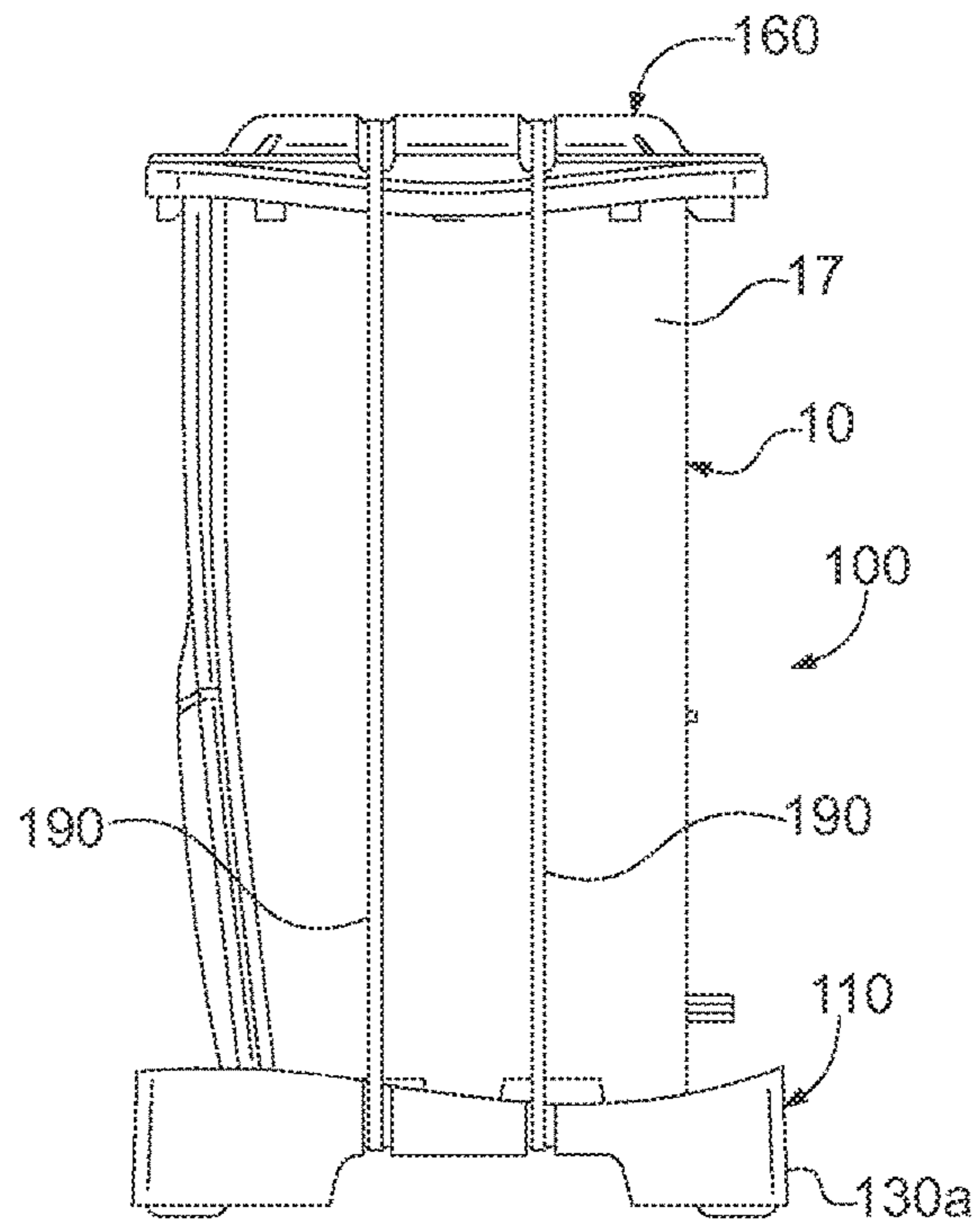
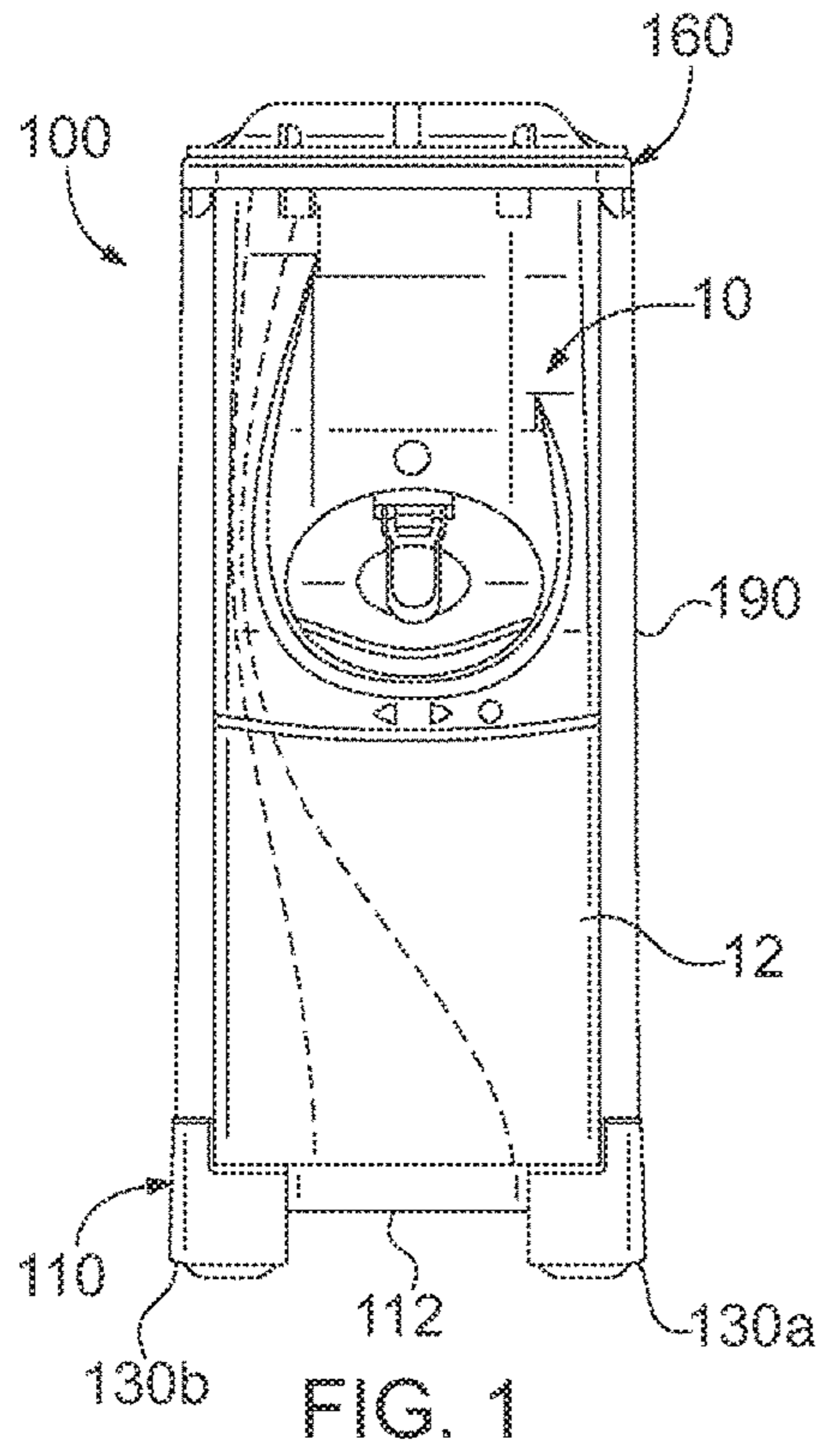

FIG. 2

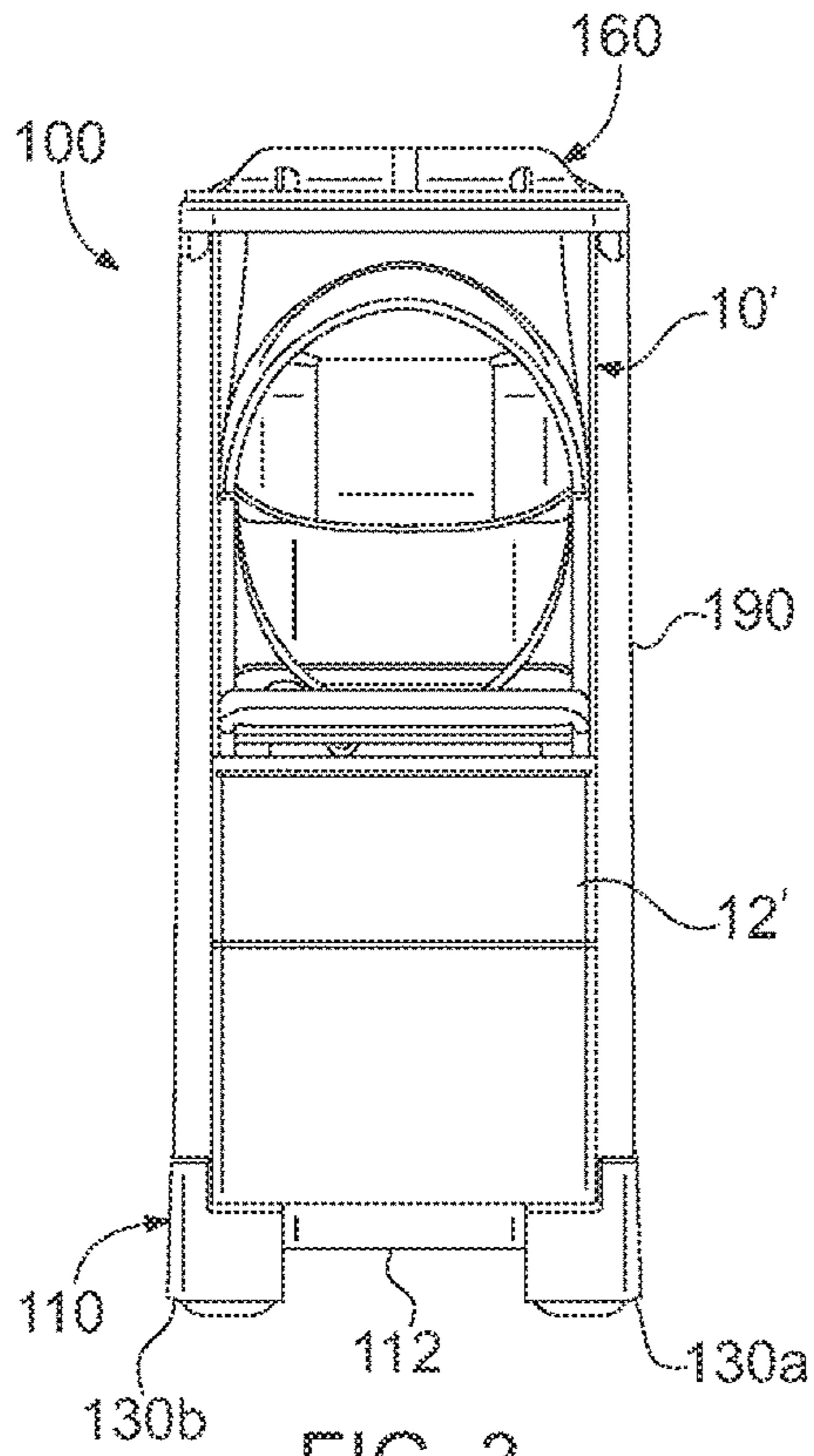

FIG. 3

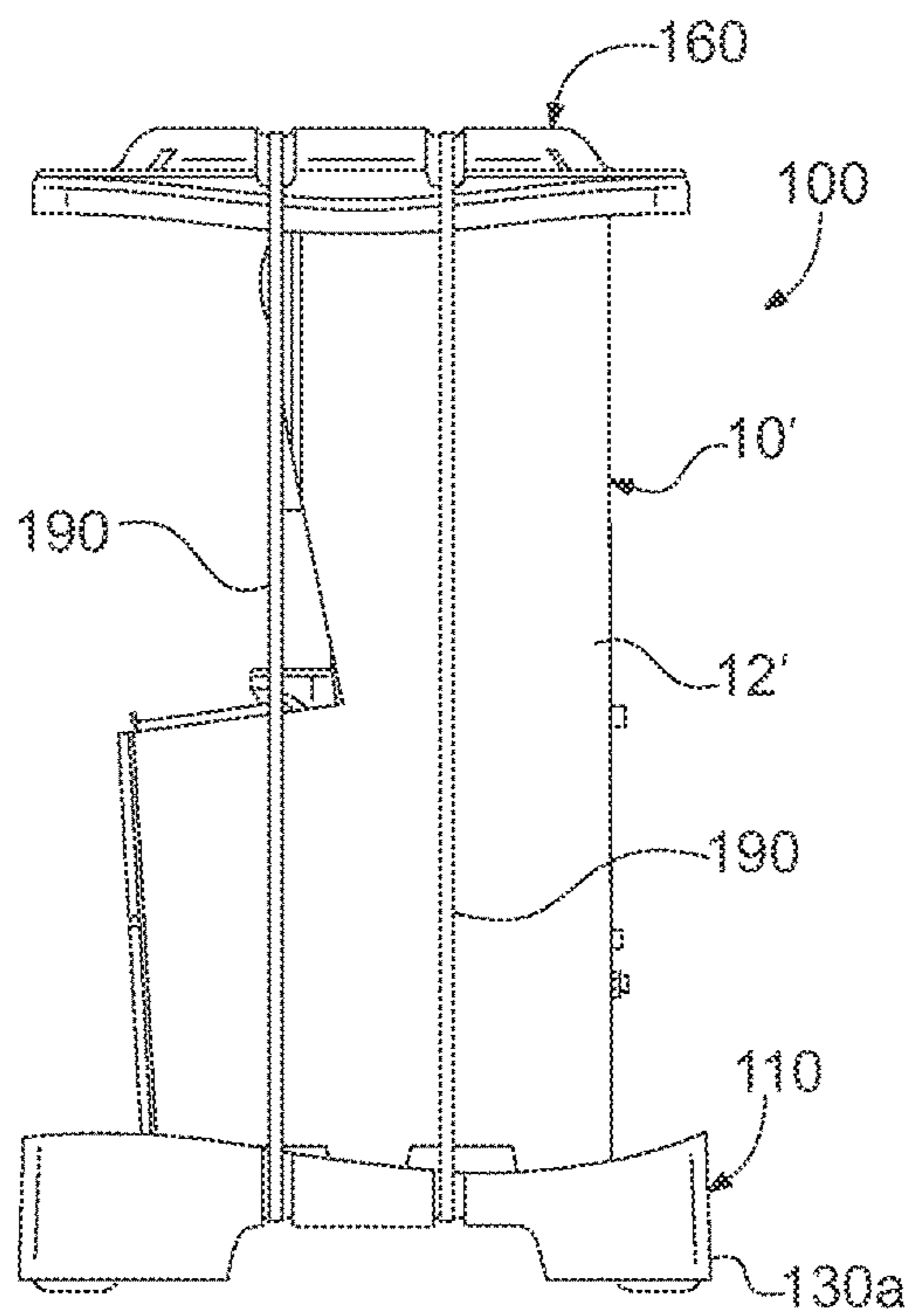

FIG. 4

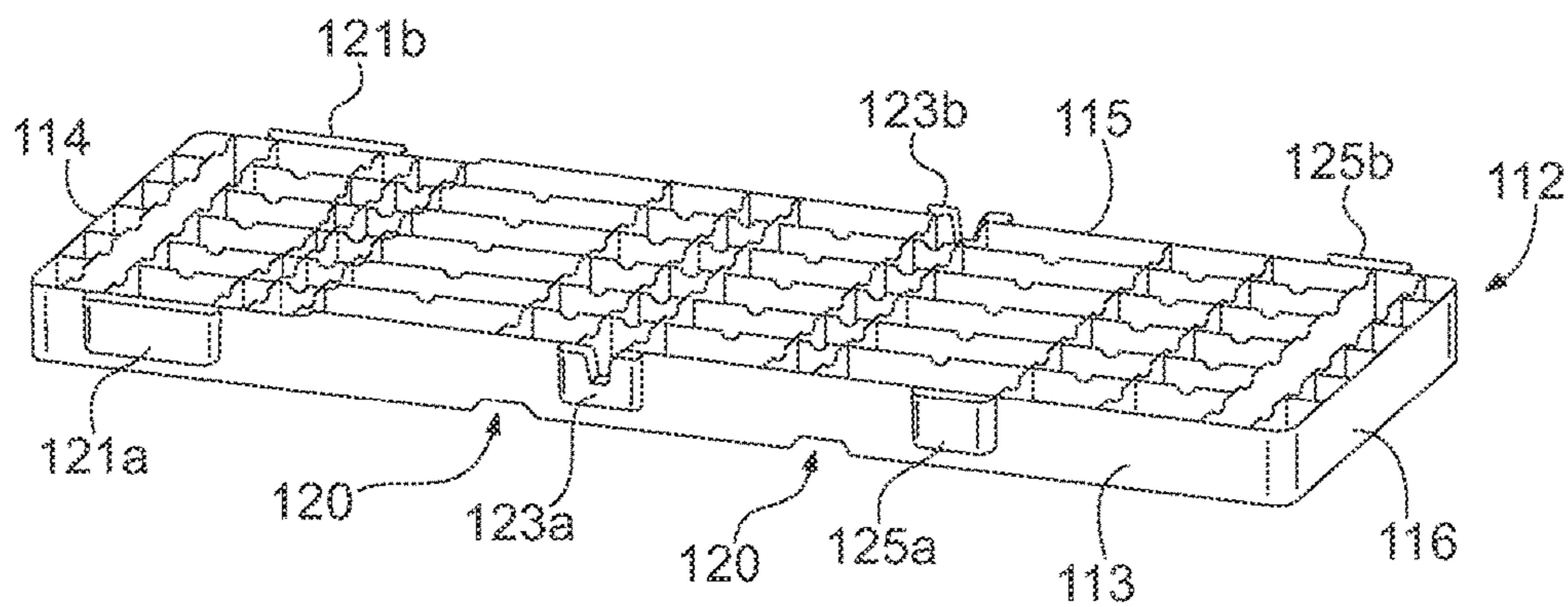

FIG. 5

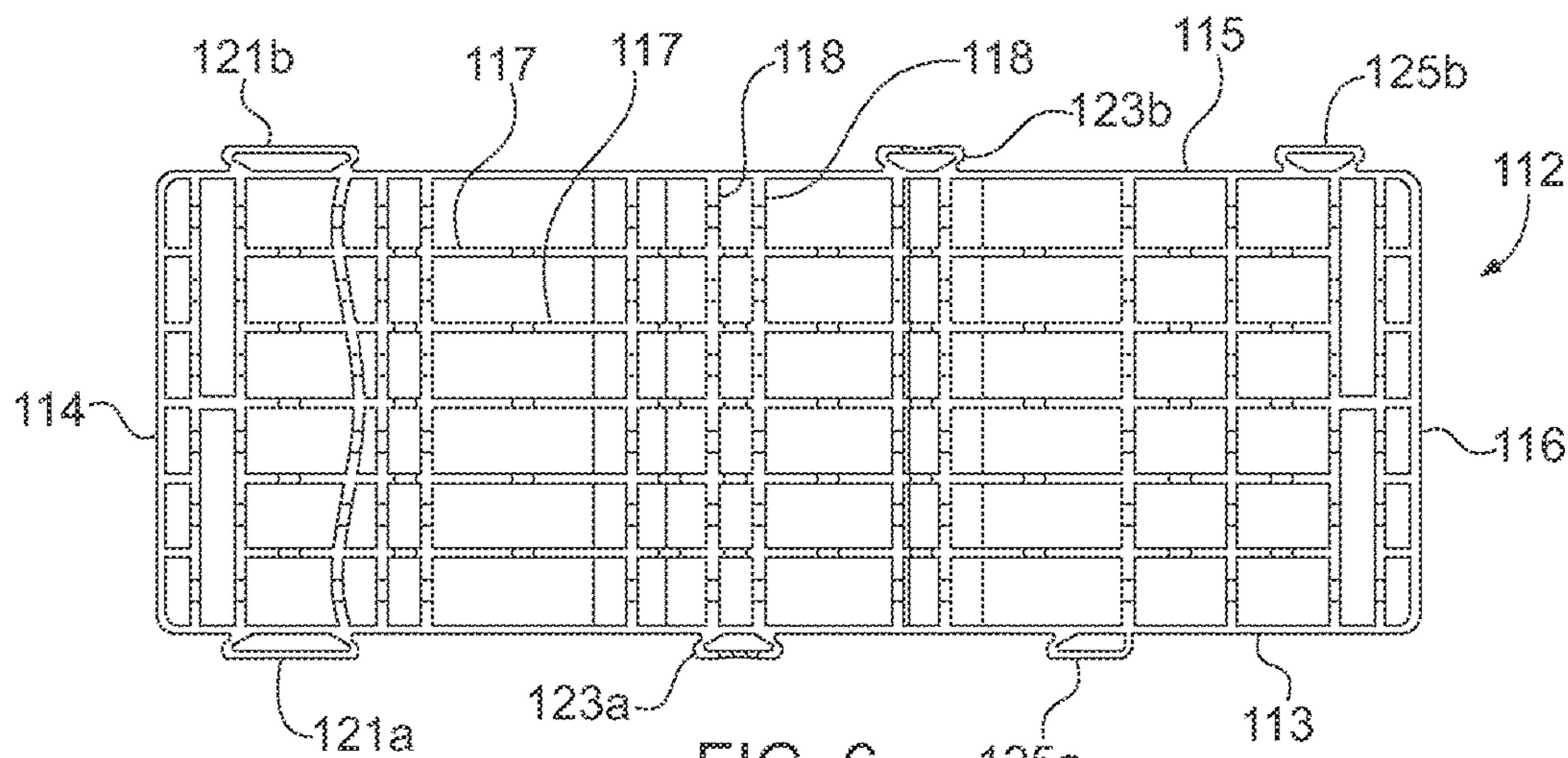

FIG. 6

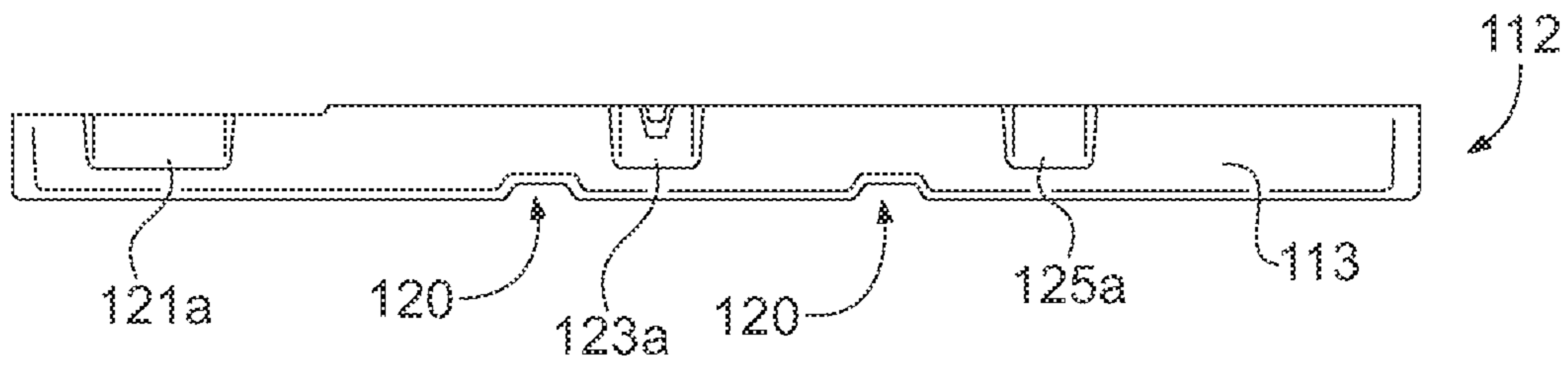

FIG. 7

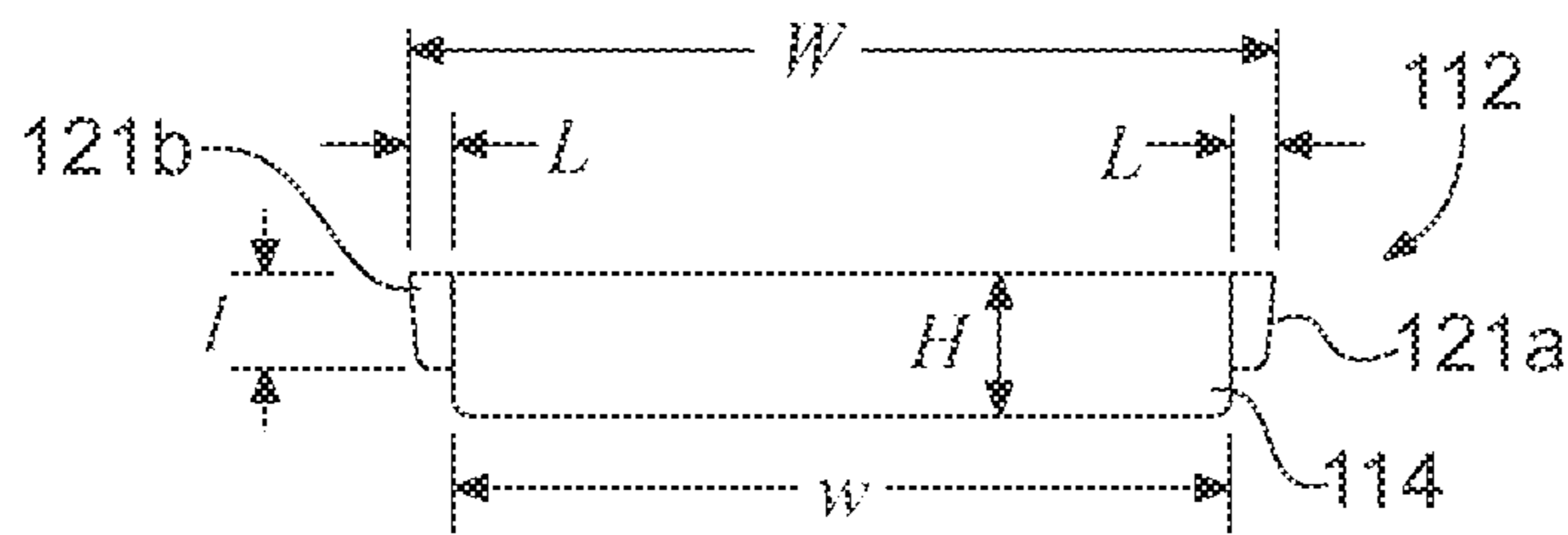
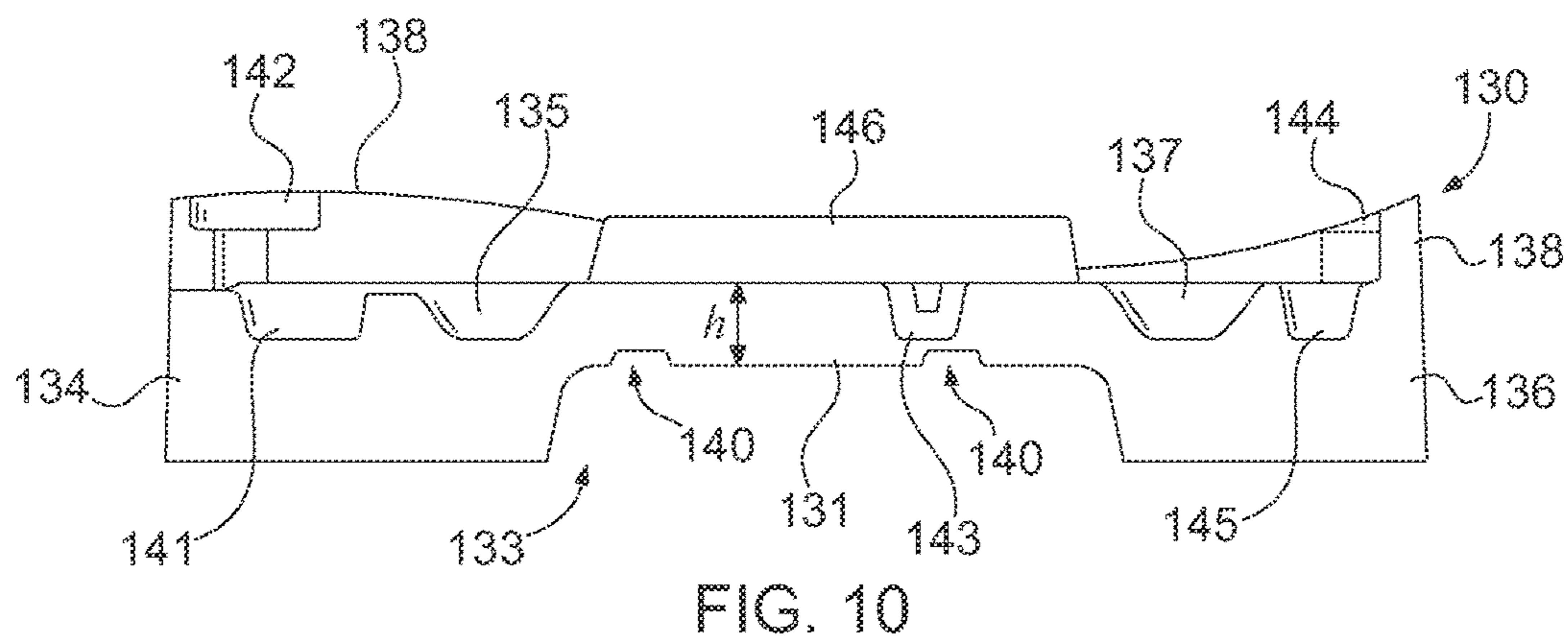
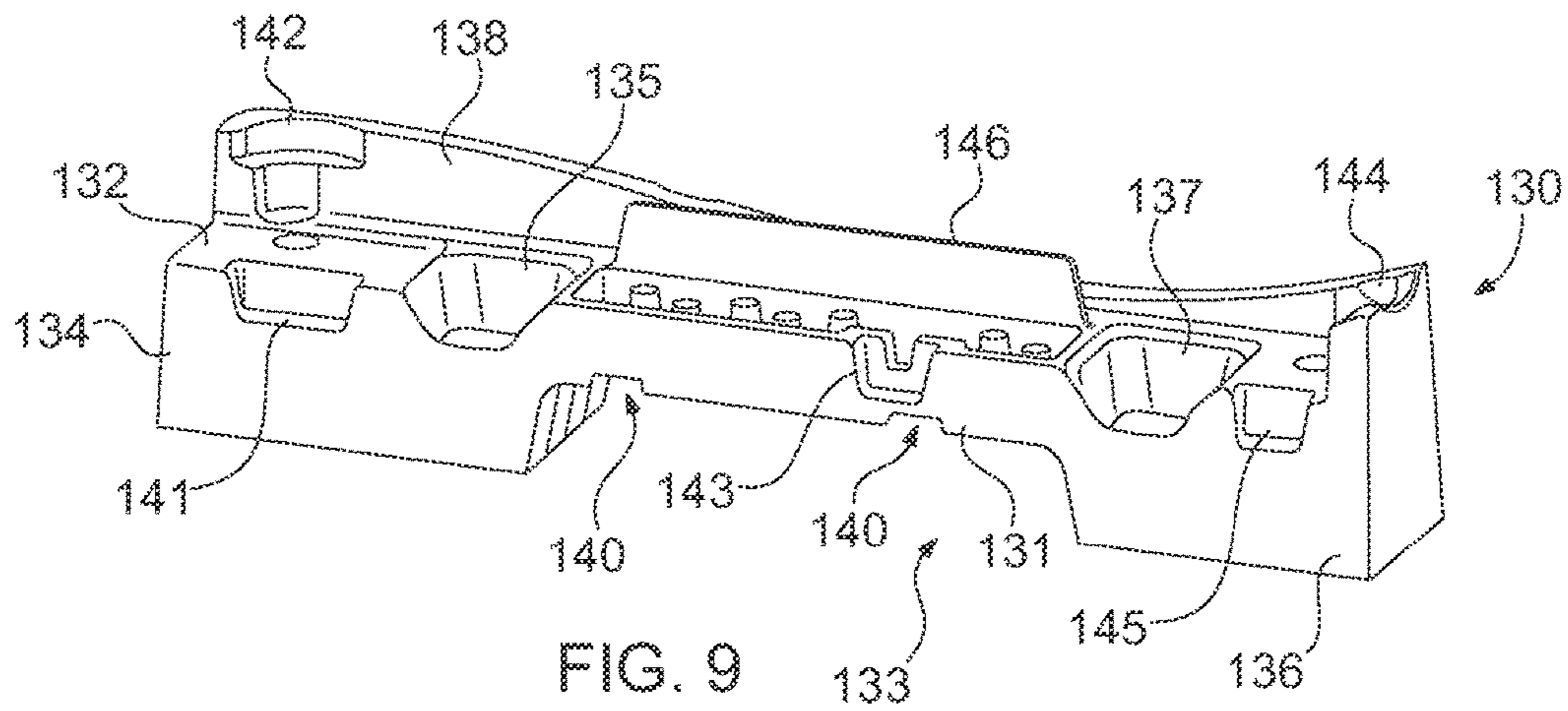

FIG. 8



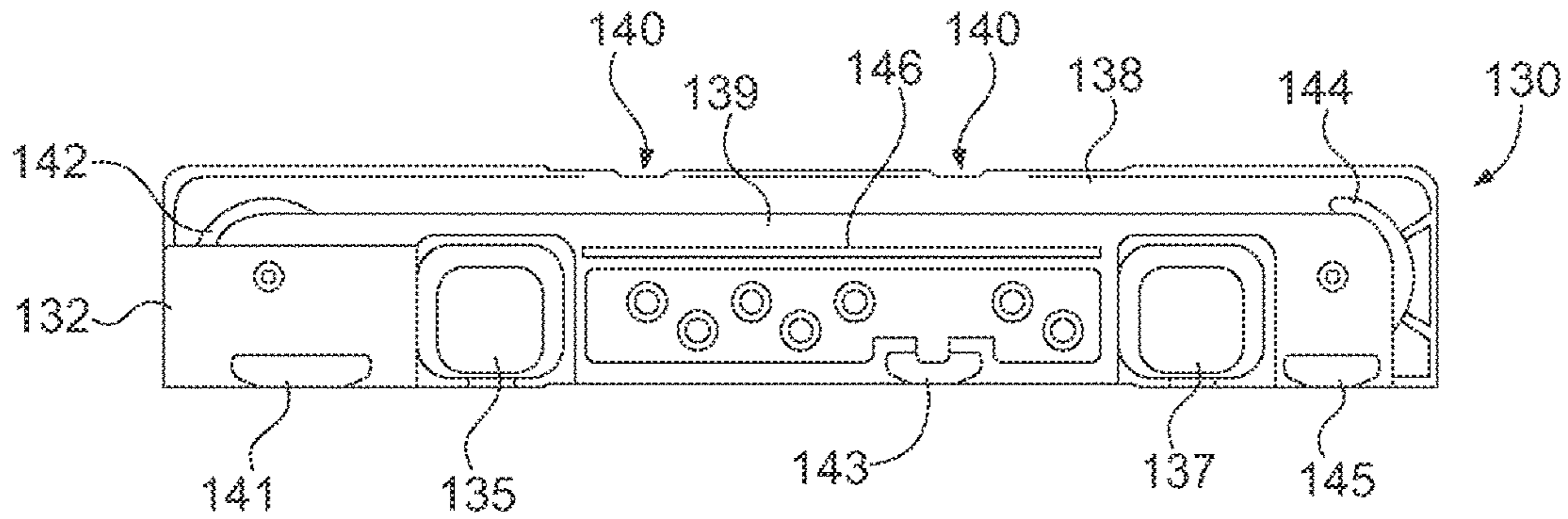

FIG. 11

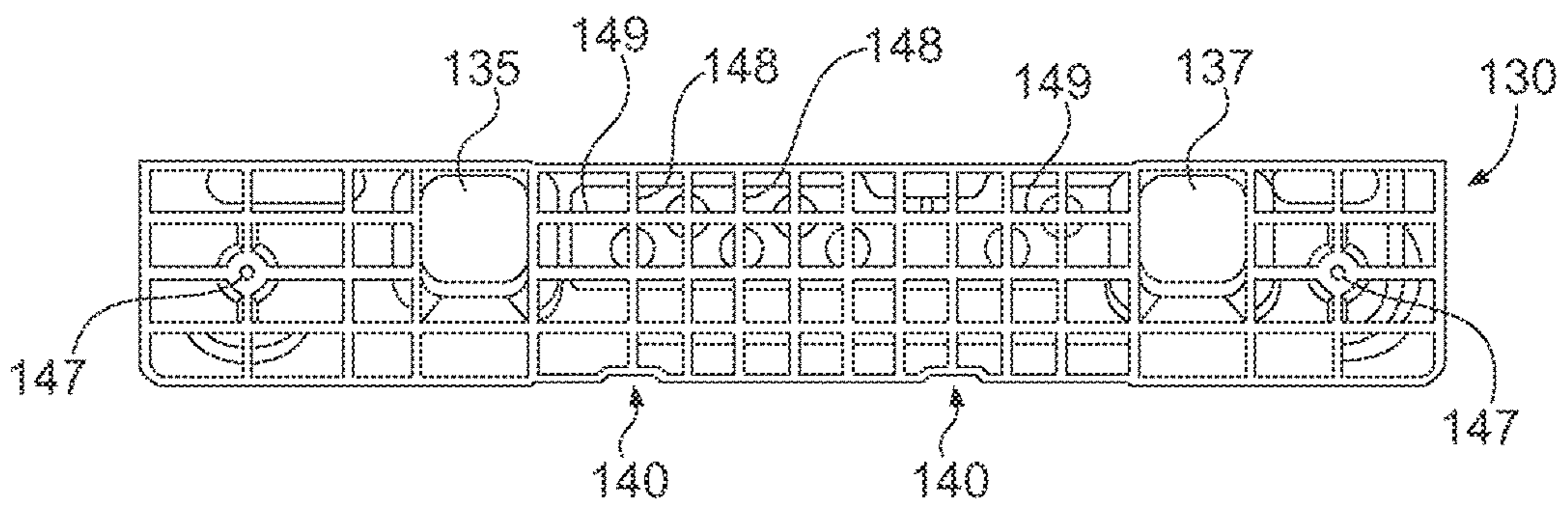
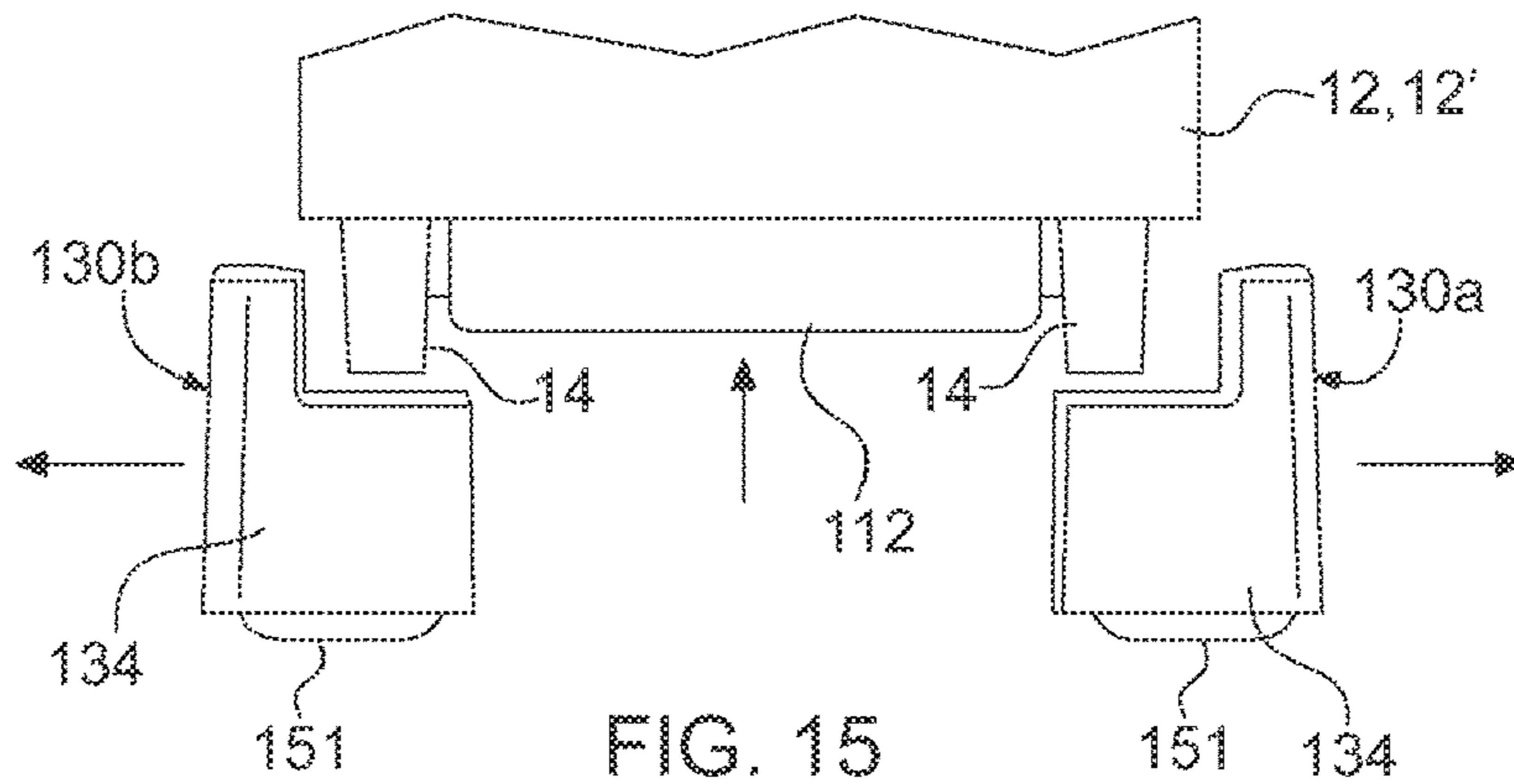
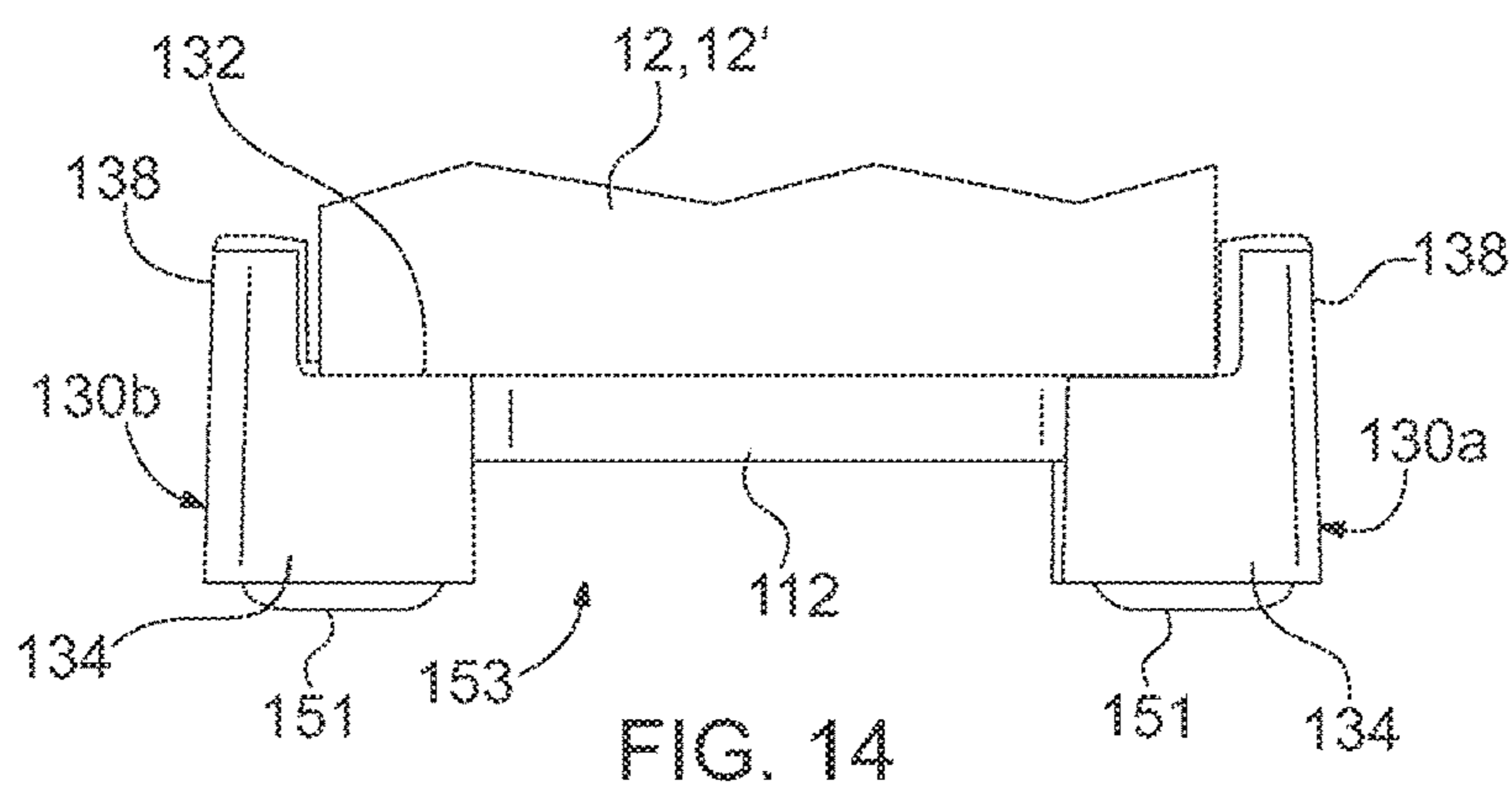
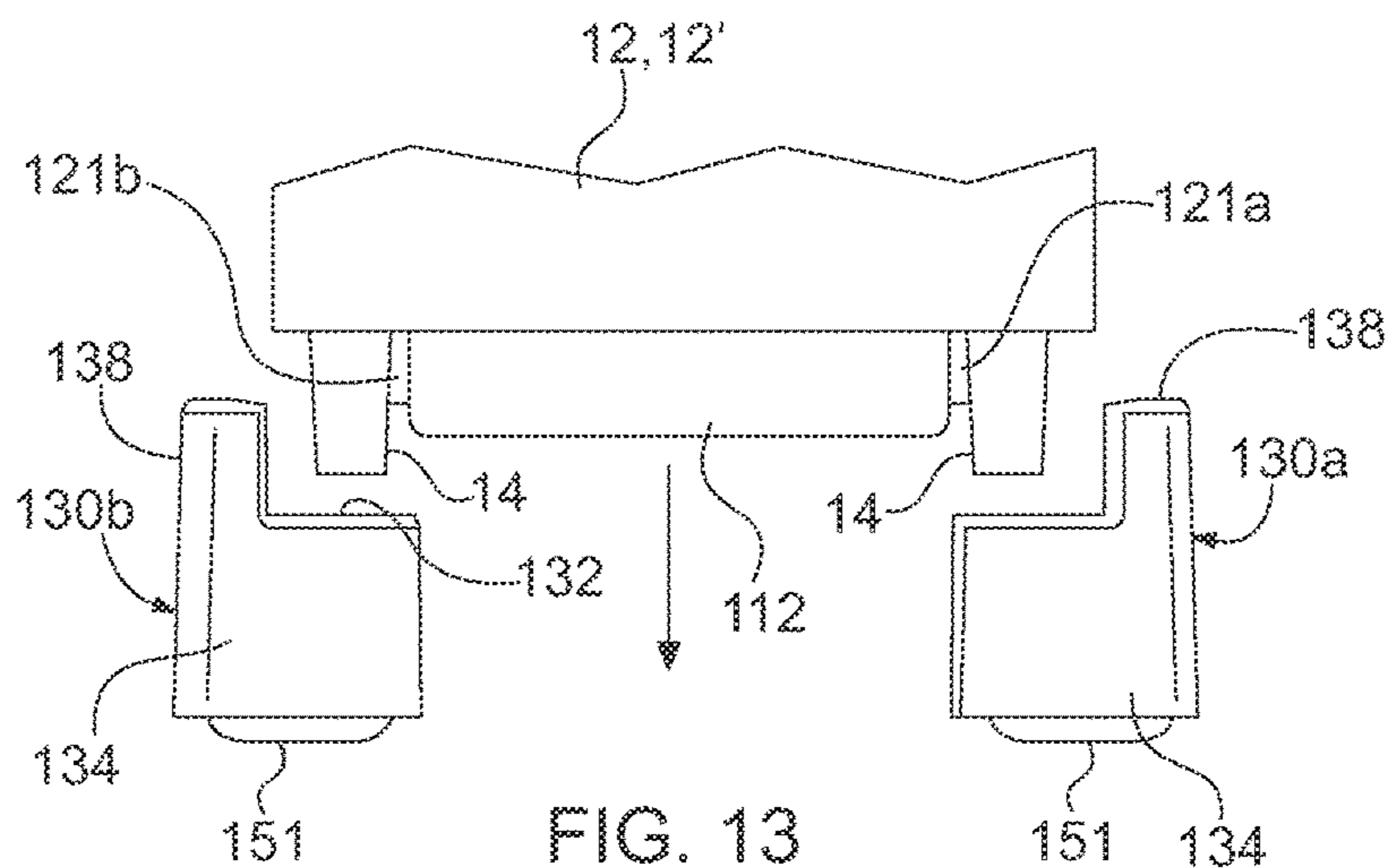

FIG. 12



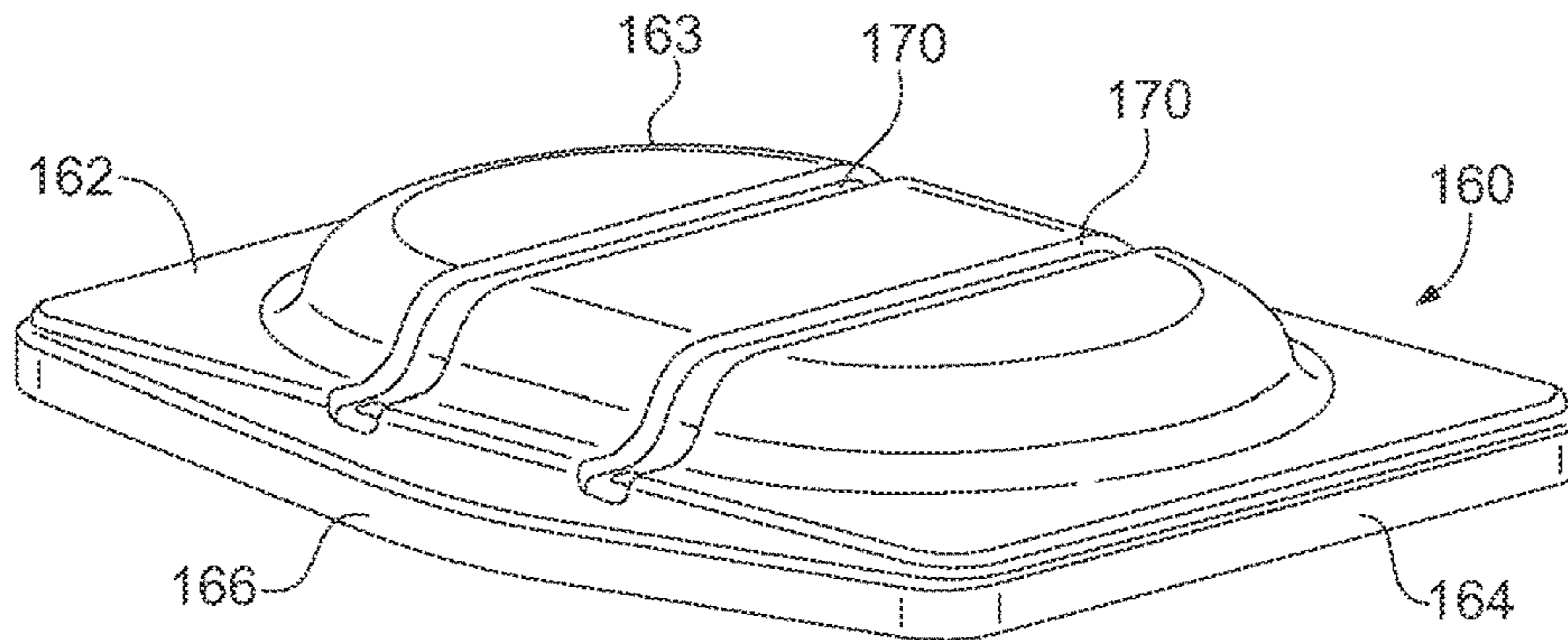

FIG. 16

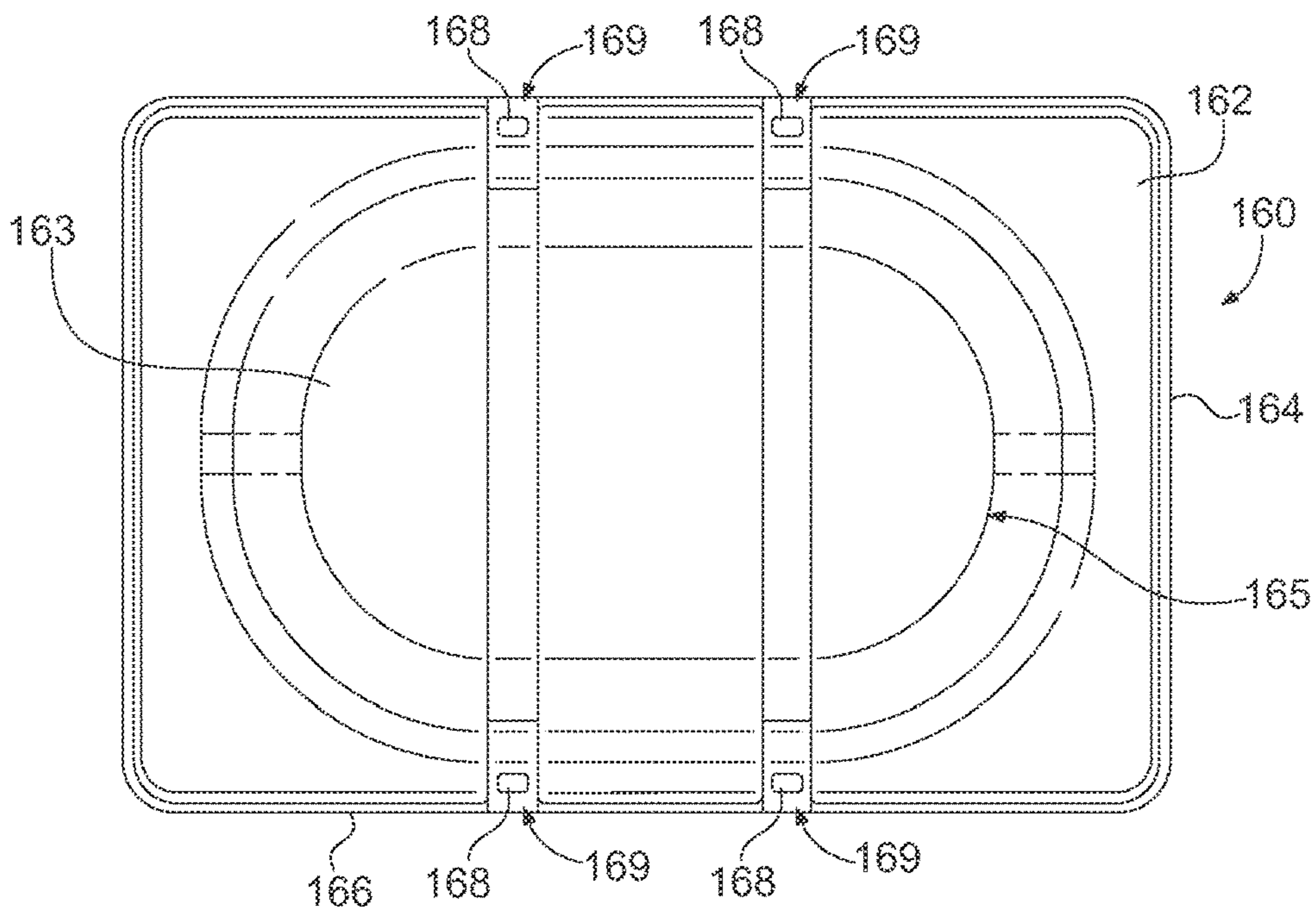

FIG. 17

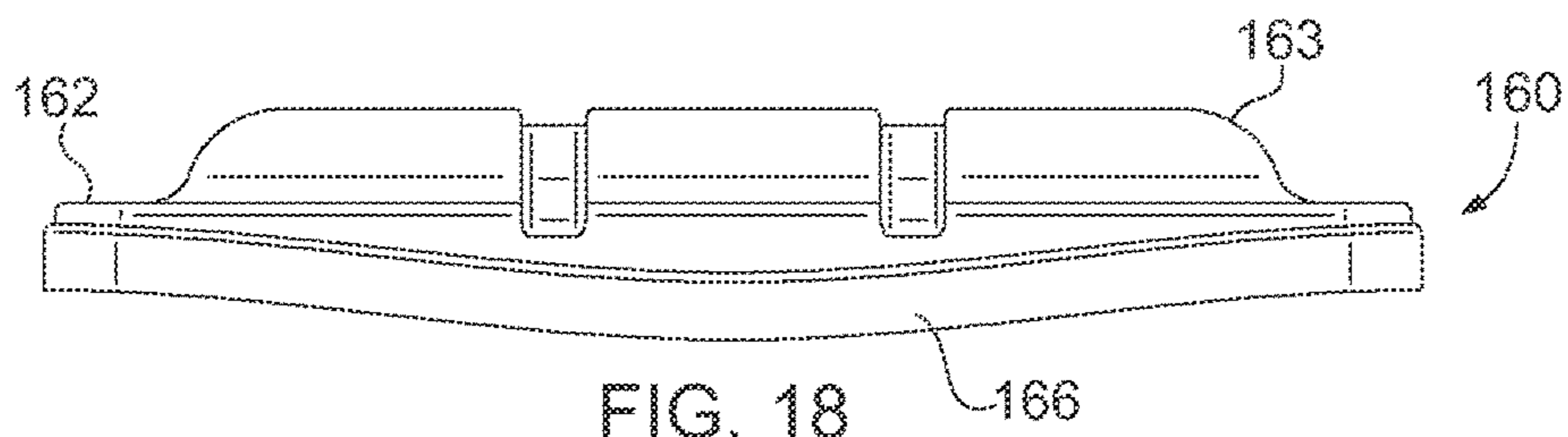
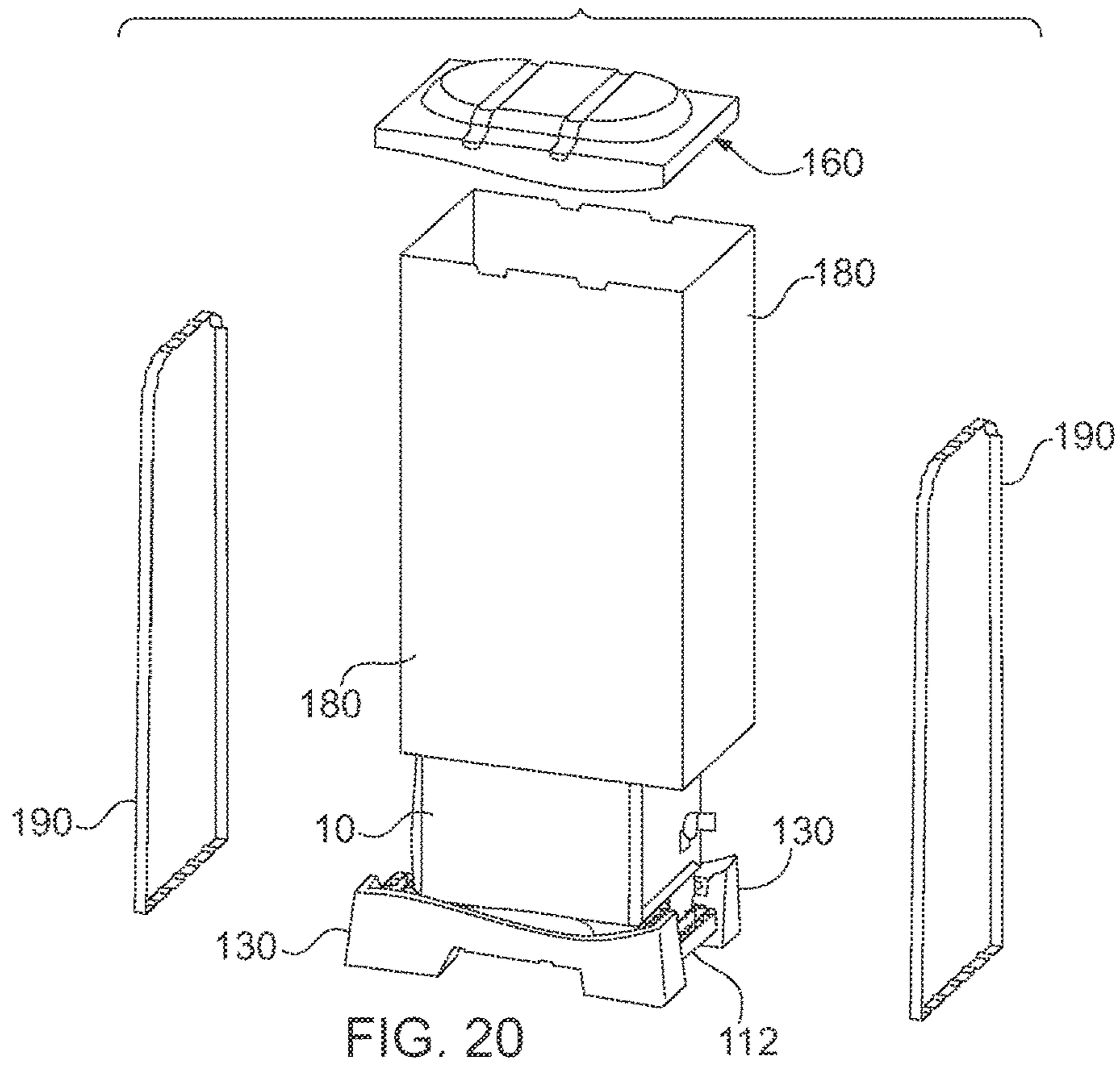
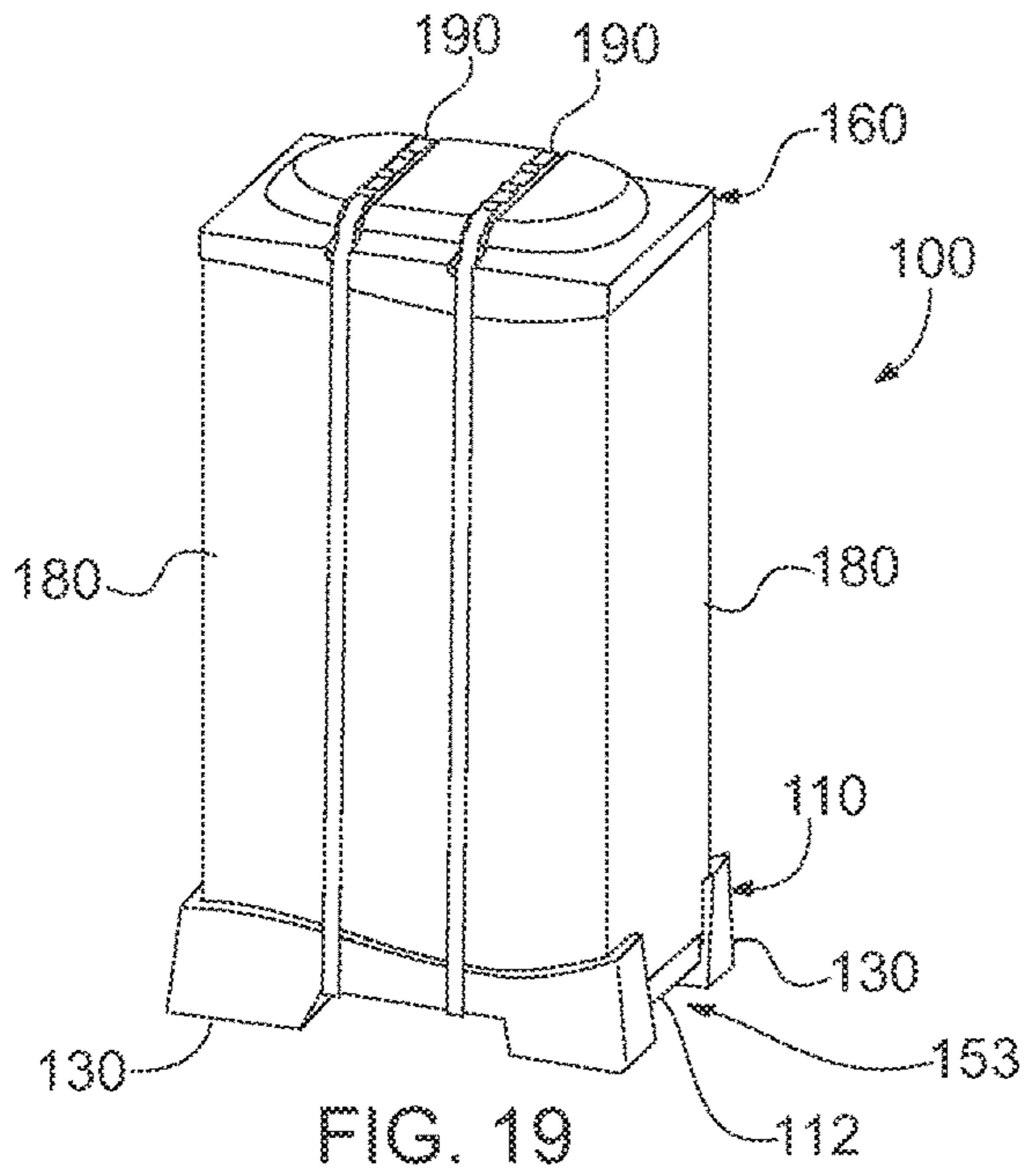

FIG. 18



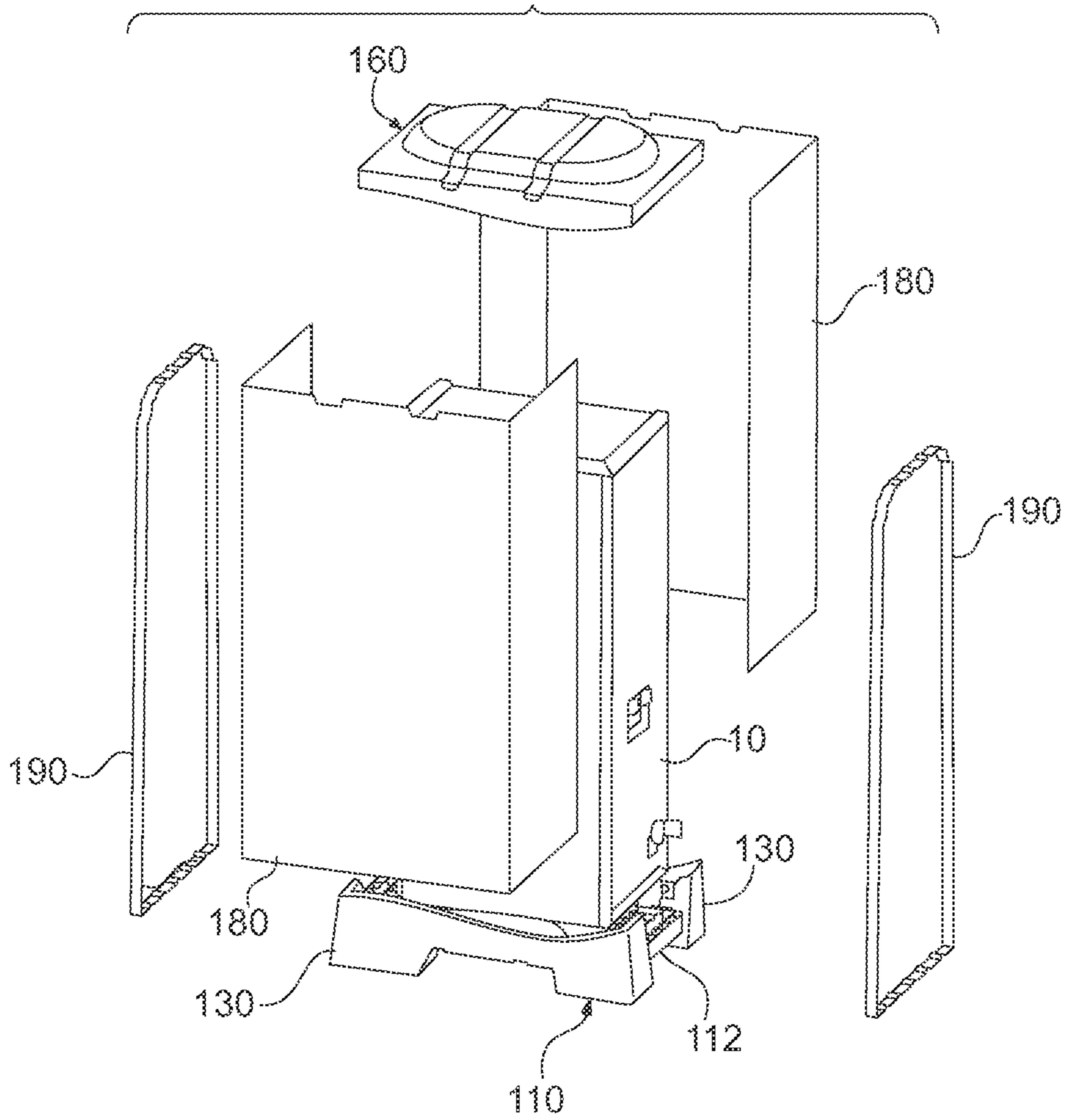

FIG. 21

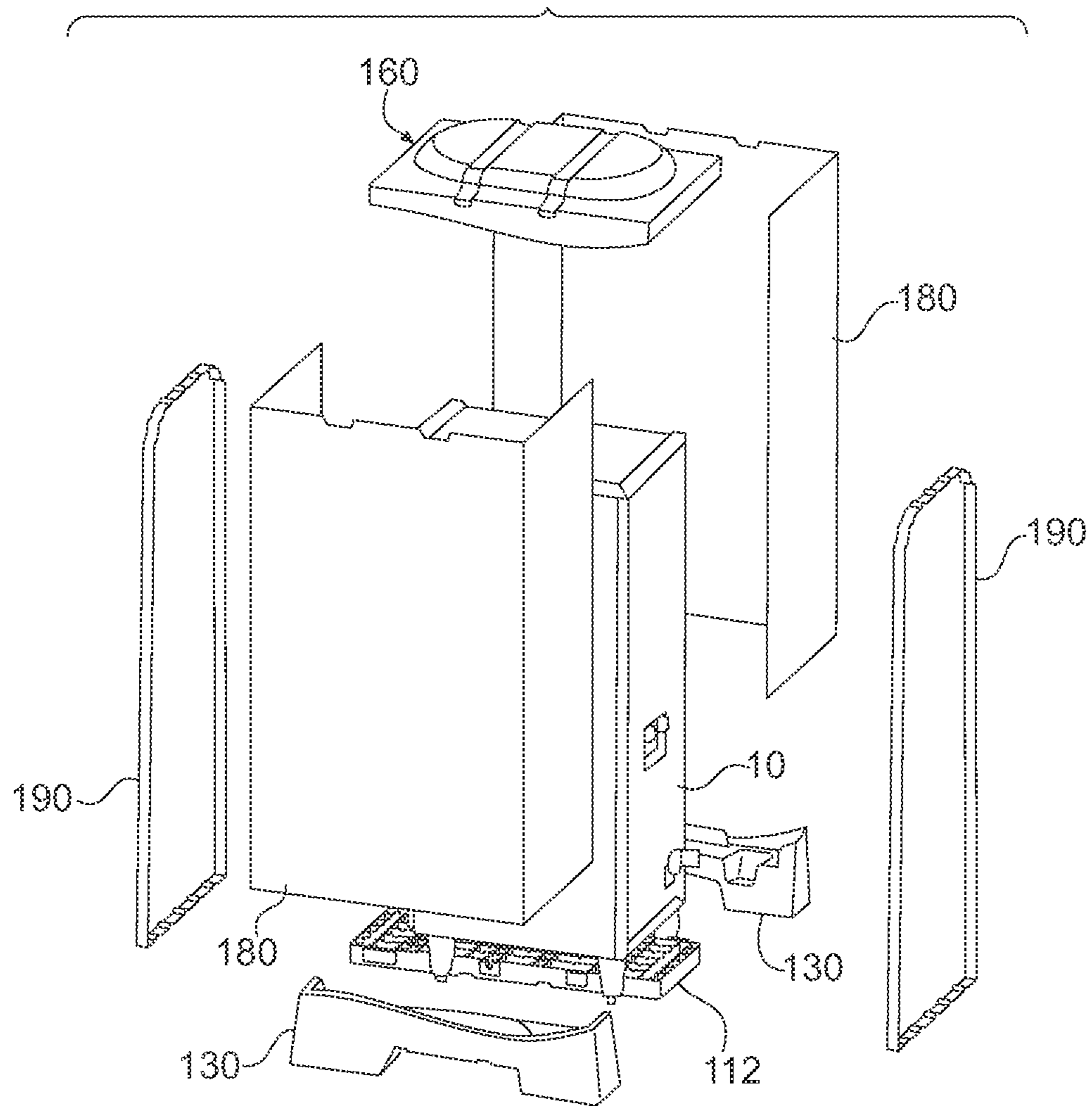

FIG. 22

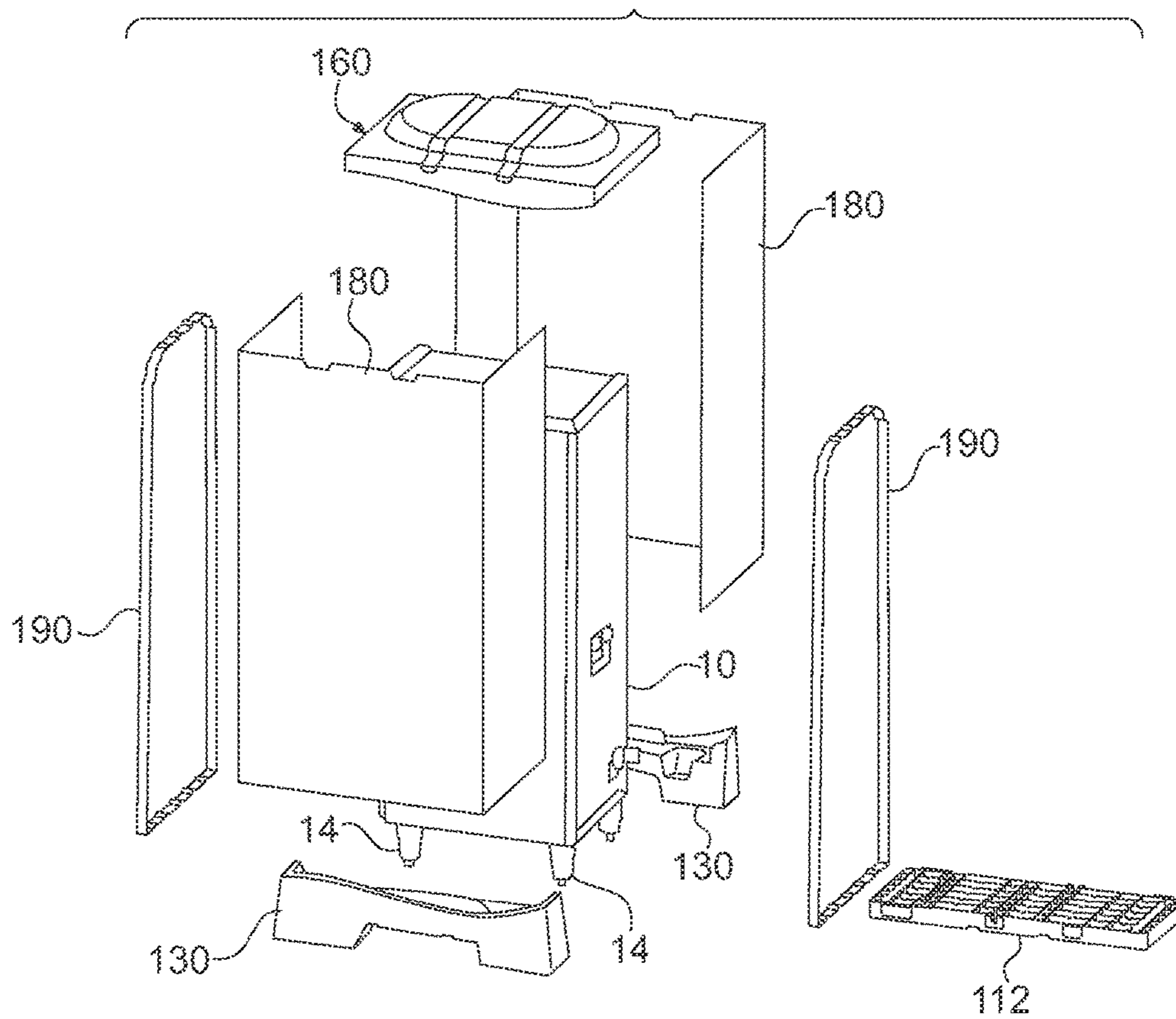

FIG. 23

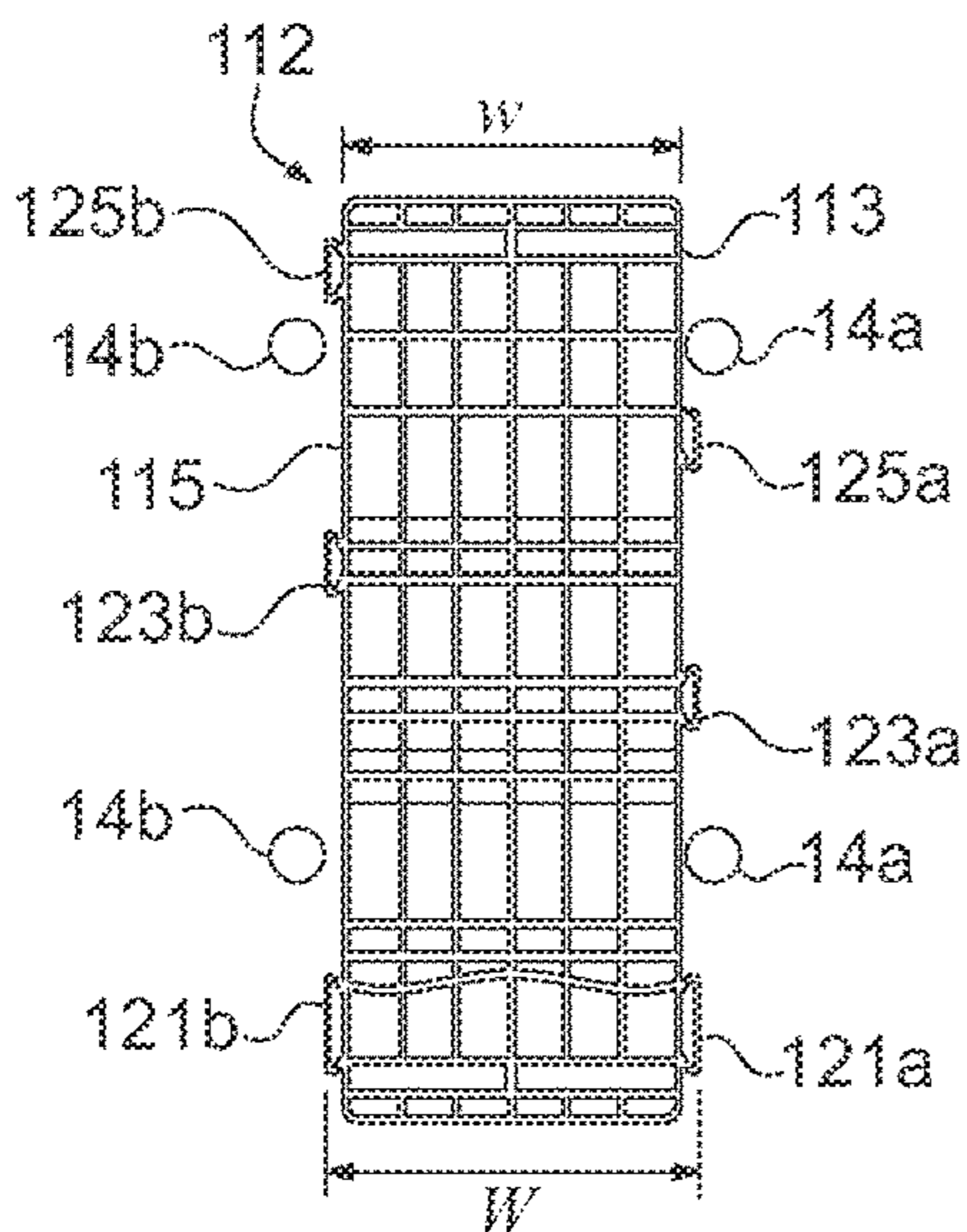

FIG. 24A

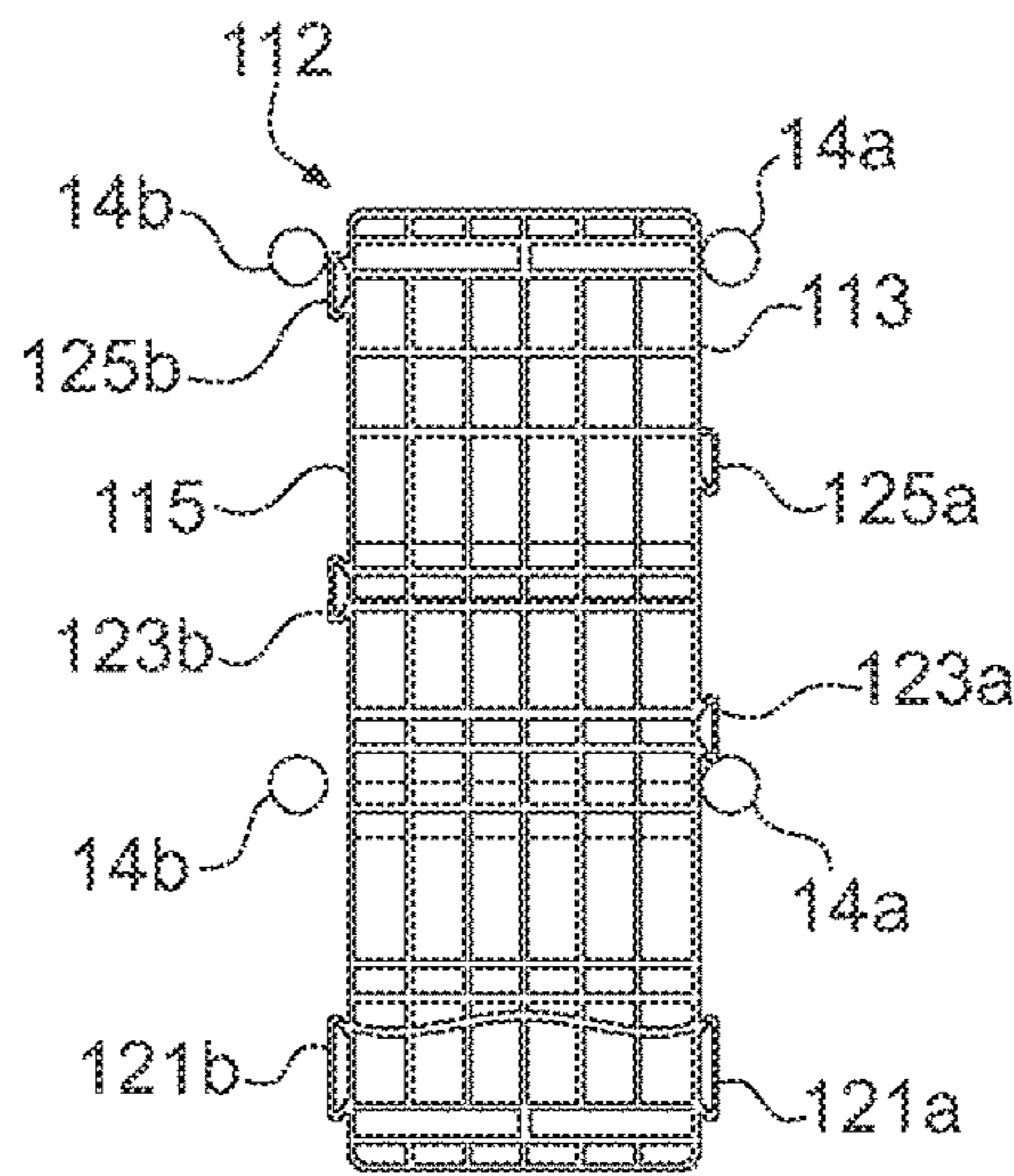

FIG. 24B

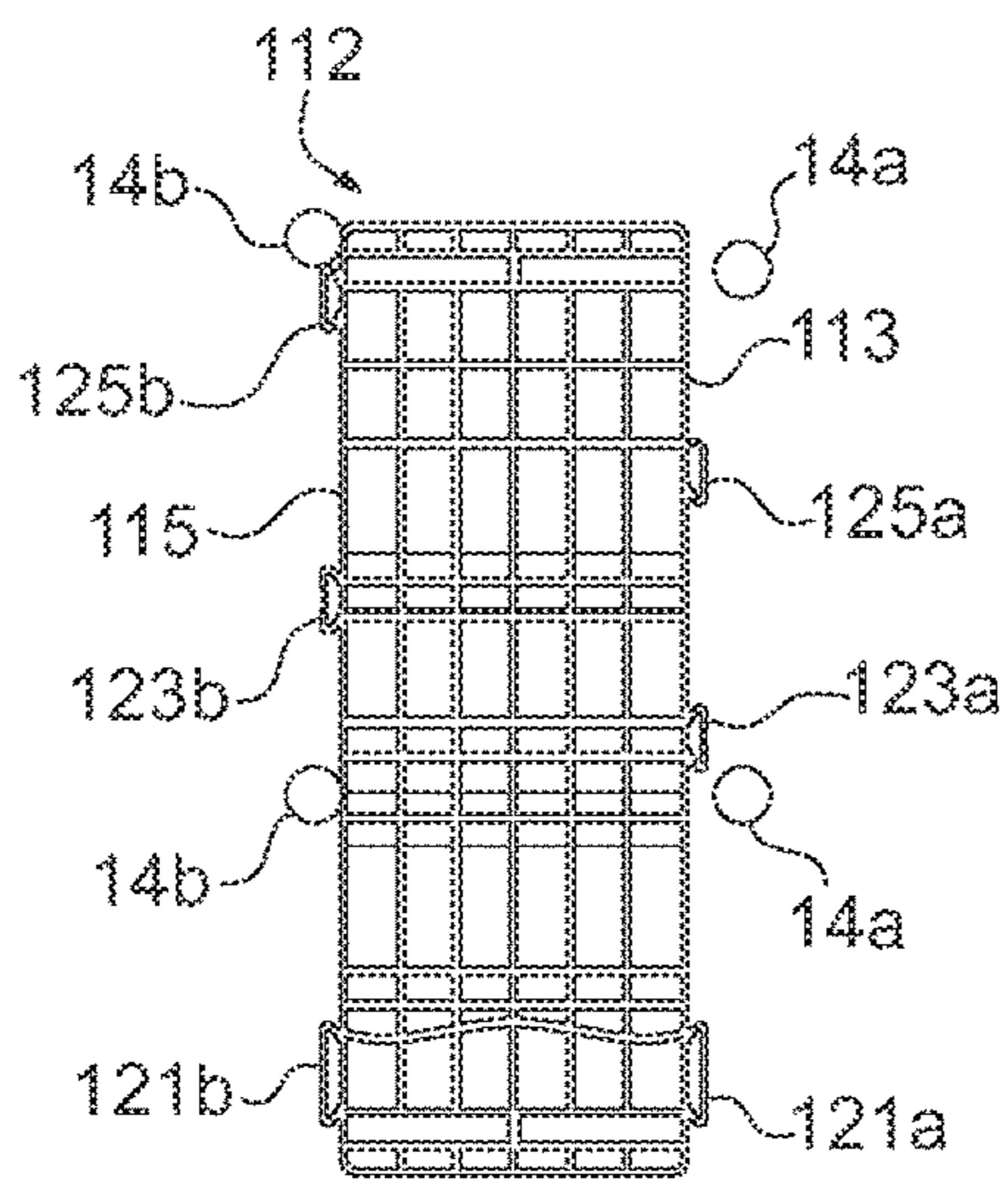

FIG. 24C

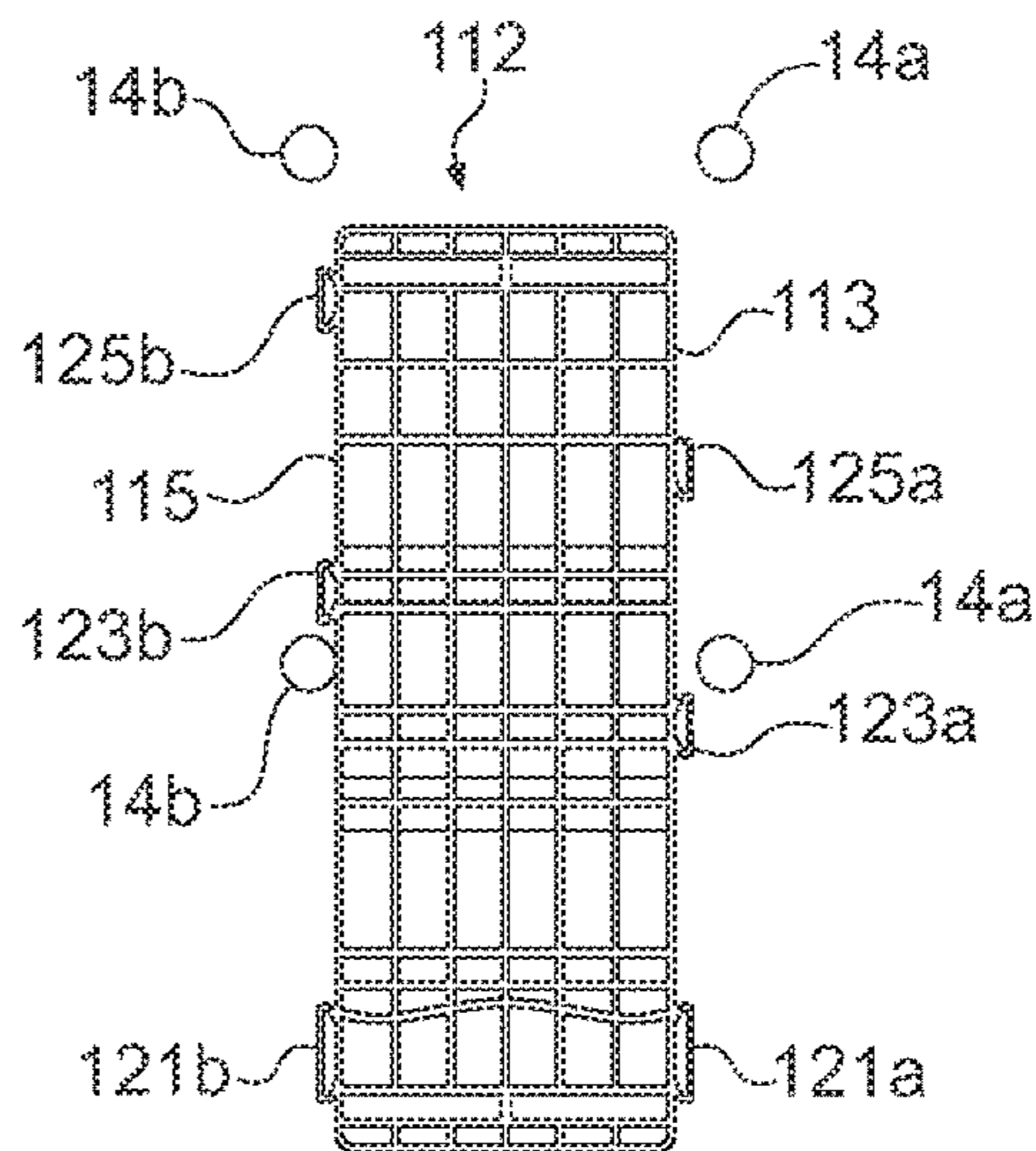
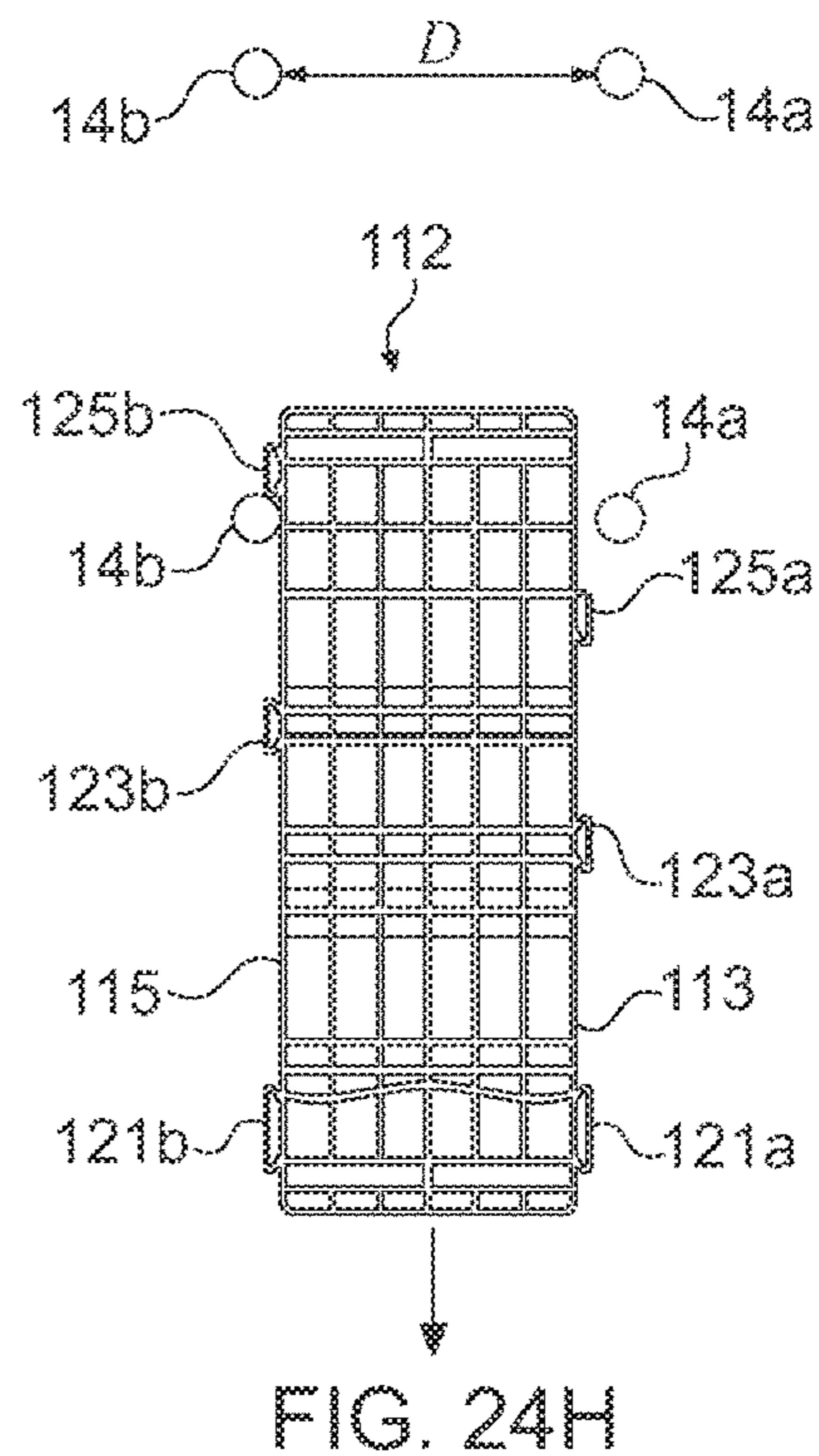
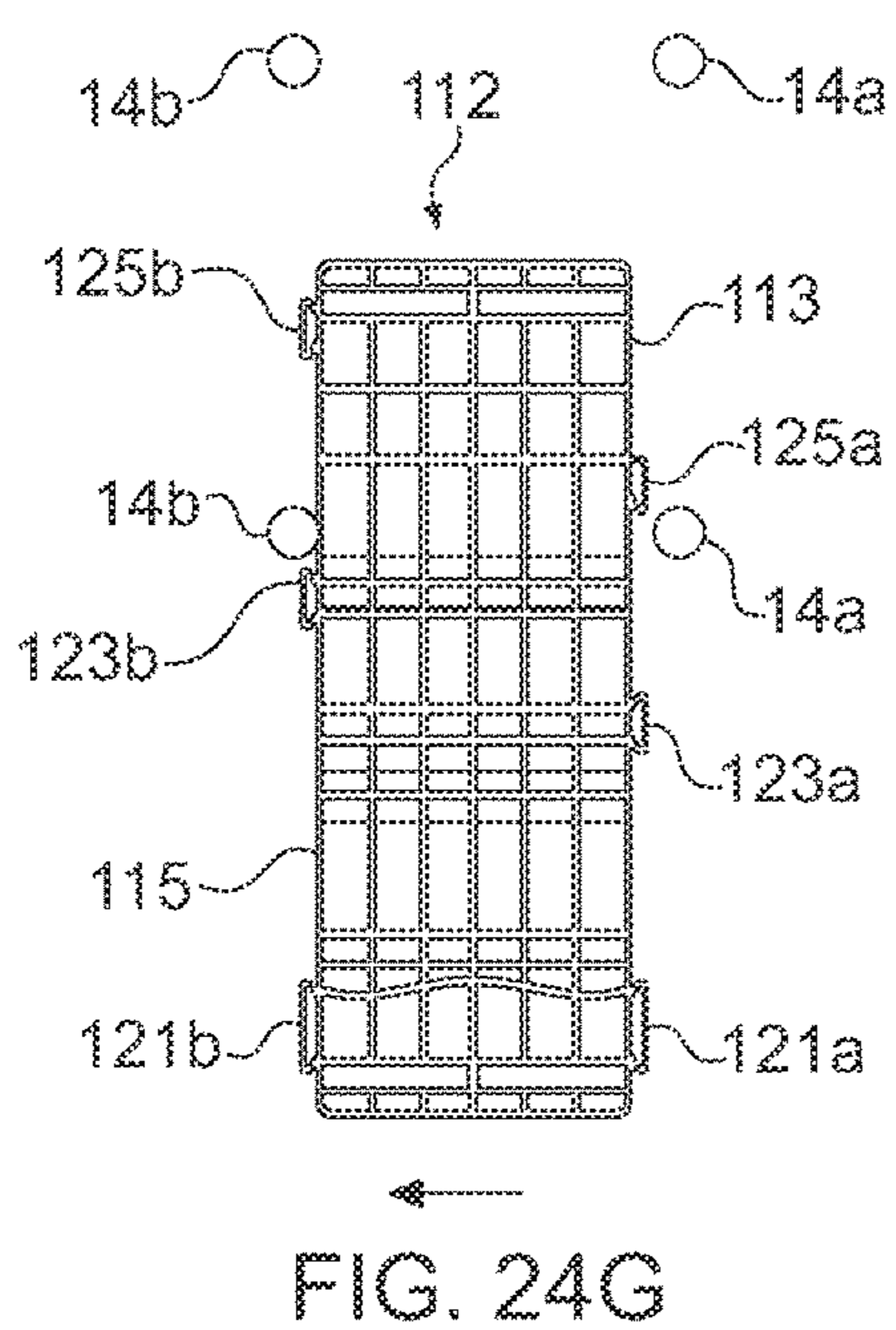
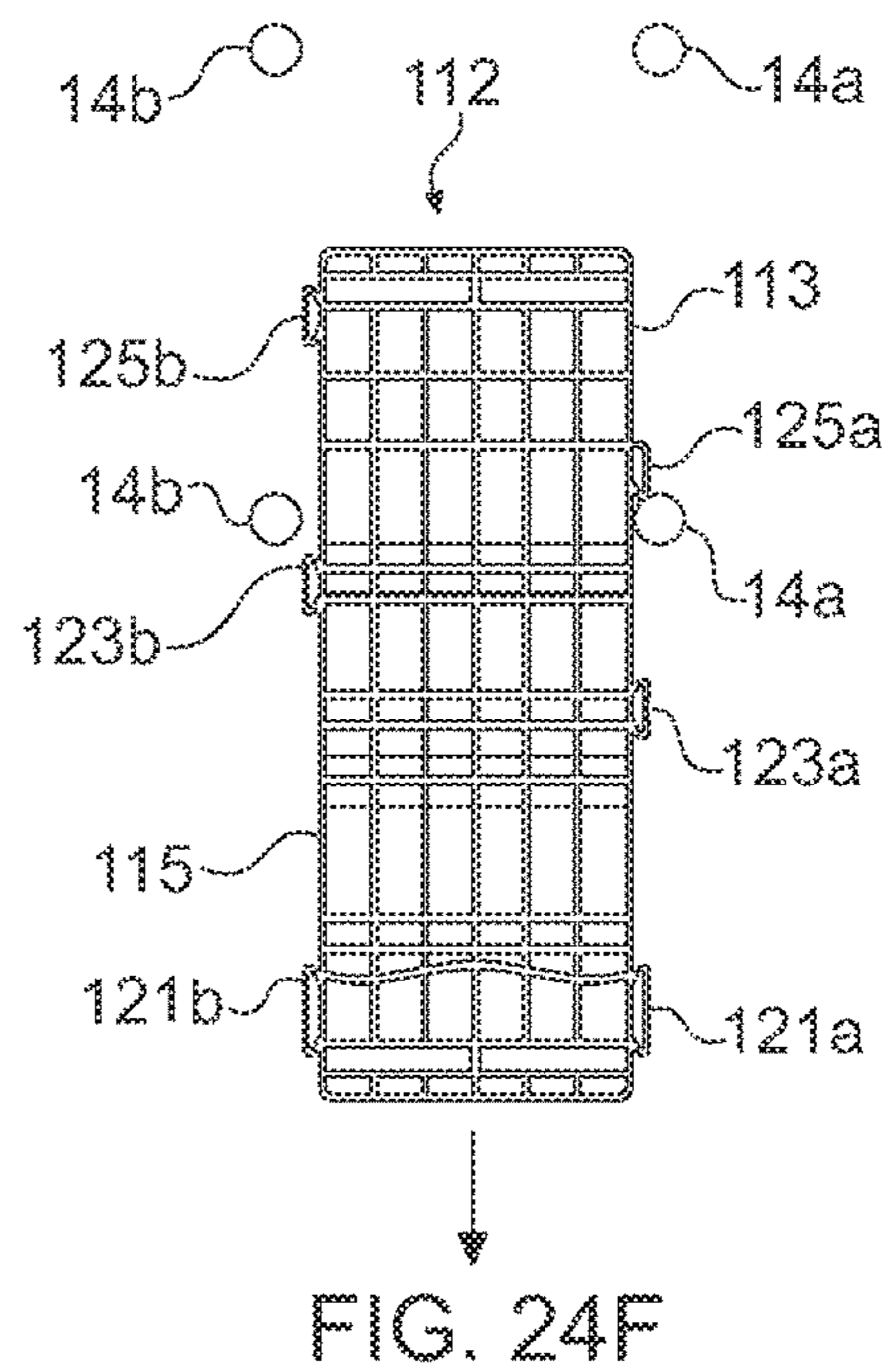
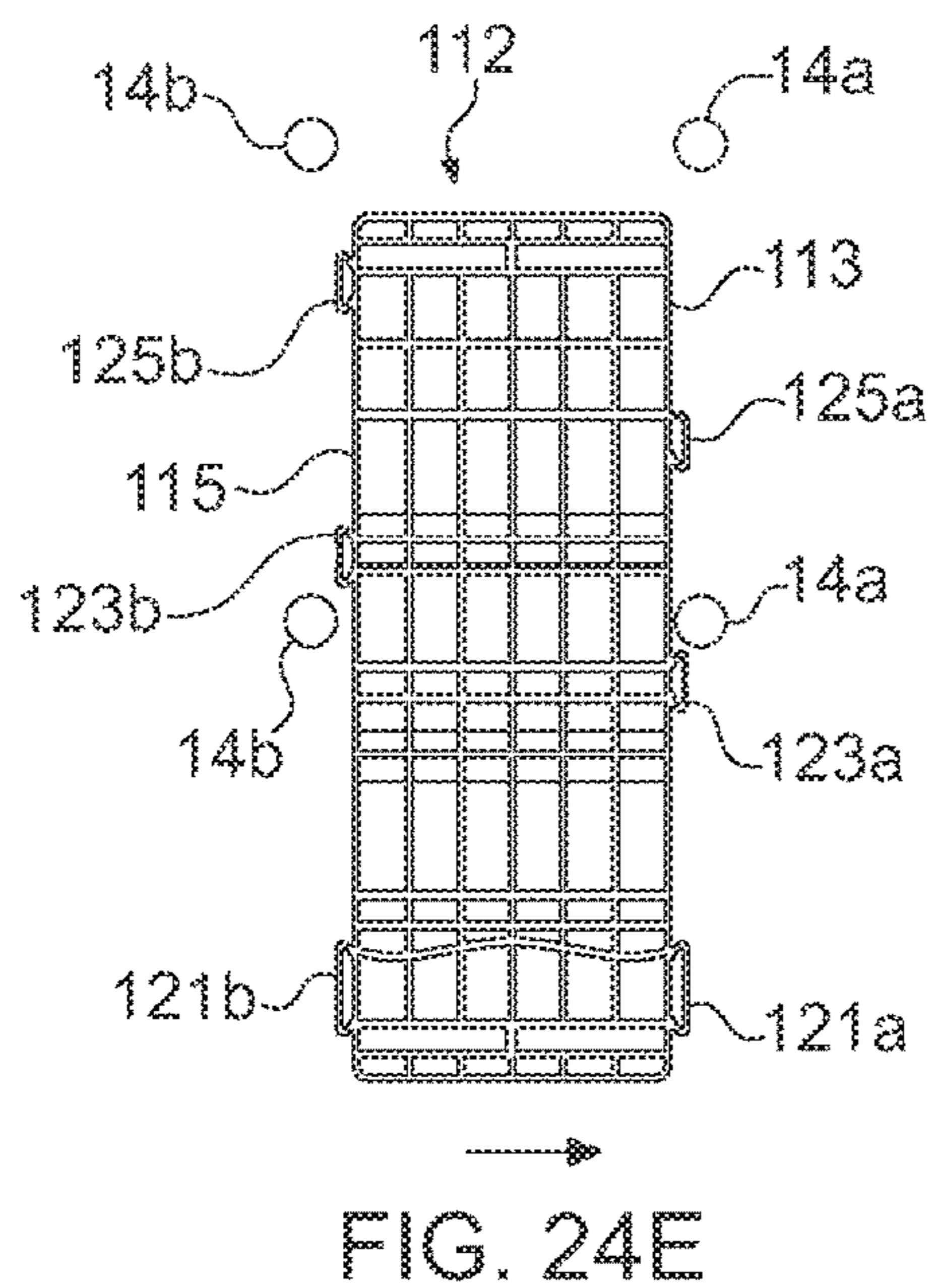

FIG. 24D



1

**METHOD OF PACKAGING A FREE
STANDING MACHINE USING A
MULTI-COMPONENT BASE STRUCTURE**

CROSS REFERENCE TO RELATED
APPLICATION

This application is a divisional of U.S. patent application Ser. No. 13/826,033 filed on Mar. 14, 2013, which claims the benefit of U.S. Provisional Appln. No. 61/665,336 filed on Jun. 28, 2012, the contents of which are incorporated herein by reference.

FIELD OF THE INVENTION

This invention relates to a packaging system for moving freestanding devices. In particular, this invention relates to a packaging system including a multi-component base structure with a center deck configured such that it can be utilized to support the freestanding device during movement.

BACKGROUND OF THE INVENTION

Freestanding devices are utilized in many industries. The devices include a housing supported on a number of legs, typically four, which depend from the housing. The housing encloses equipment for a given application, for example, food or beverage vending equipment, computer kiosks, automated teller assemblies, or rental equipment as a few examples. A specific example is a freestyle fountain vending machine which has a beverage dispenser, touch-screen input, computer controller, and fountain beverages all housed within the housing. FIGS. 1-4 illustrate two exemplary freestyle fountain vending machines packaged within a packaging system in accordance with the present invention. The exemplary freestyle fountain vending machines each include four legs (not shown) which support the housing a given distance off the floor or other support system.

The freestanding devices are typically manufactured by a manufacturer in a manufacturing facility with all of the equipment assembled into the housing such that the device requires minimal setup once delivered to a use location. Additionally, the housing is often finished with a desired look, for example, company branding or matching the décor of the use location. The freestanding device is delivered from the manufacturing facility to the use location, is set in position, and final connections, for example connection to a power supply and/or network, are made to activate the device.

Since the housing is often finished and houses potentially delicate equipment, it is desirable to deliver the freestanding device in a secure manner which protects the housing and the equipment inside thereof. It is also desirable to utilize packaging which allows easy transport of the device. It is further desirable to utilize packaging which is easy to remove without significant effort.

SUMMARY OF THE INVENTION

Briefly, the present invention provides a packaging system including a multi-component base structure with a center deck configured such that it can be utilized to support the freestanding device during movement.

In one aspect, the invention provides a pallet base structure including a center deck defining a support surface extending between opposed sides and having at least two

2

lugs extending from each of the opposed sides. A pair of base side members are positioned along respective sides of the center deck. Each base side member has first and second spaced apart base legs and a support member extending between the base legs with at least two corresponding lug receiving slots defined in the support member. The respective lugs are received in the respective lug receiving slots such that the center deck support surface is aligned with an upper surface of each support member to define a planar pallet surface.

In another aspect, the invention provides a packaging system incorporating a pallet base structure including a center deck defining a support surface extending between opposed sides and having at least two lugs extending from each of the opposed sides. A pair of base side members are positioned along respective sides of the center deck. Each base side member has first and second spaced apart base legs and a support member extending between the base legs with at least two corresponding lug receiving slots defined in the support member. The respective lugs are received in the respective lug receiving slots such that the center deck support surface is aligned with an upper surface of each support member to define a planar pallet surface. A cover member is configured to be positioned spaced from the pallet base structure and at least one strap member is configured to extend about the pallet base structure and the cover member such that the pallet base structure and the cover member are an interconnected unit.

BRIEF DESCRIPTION OF THE DRAWINGS

The accompanying drawings, which are incorporated herein and constitute part of this specification, illustrate the presently preferred embodiments of the invention, and, together with the general description given above and the detailed description given below, serve to explain the features of the invention. In the drawings:

FIG. 1 is a front elevation view of a packaging system in accordance with an embodiment of the present invention positioned about an exemplary freestanding device.

FIG. 2 is a side elevation view of the assembly of FIG. 1.

FIG. 3 is a front elevation view of a packaging system in accordance with an embodiment of the present invention positioned about another exemplary freestanding device.

FIG. 4 is a side elevation view of the assembly of FIG. 3.

FIG. 5 is a perspective view of an exemplary base center deck in accordance with an embodiment of the invention.

FIG. 6 is a top plan view of the exemplary base center deck of FIG. 5.

FIG. 7 is a left side elevation view of the exemplary base center deck of FIG. 5.

FIG. 8 is a front elevation view of the exemplary base center deck of FIG. 5.

FIG. 9 is a perspective view of an exemplary right base side member in accordance with an embodiment of the invention.

FIG. 10 is an elevation view of the exemplary right base side member of FIG. 9.

FIG. 11 is a top plan view of the exemplary right base side member of FIG. 9.

FIG. 12 is a bottom plan view of the exemplary right base side member of FIG. 9.

FIG. 13 is a perspective view of an exemplary cover member in accordance with an embodiment of the invention.

FIG. 14 is a top plan view of the exemplary cover member of FIG. 13.

FIG. 15 is a side elevation view of the exemplary cover member of FIG. 13.

FIG. 16 is a front elevation view illustrating positioning of the exemplary base center deck relative to the exemplary base side members.

FIG. 17 is a front elevation view similar to FIG. 16 and illustrating the base center deck and the freestanding device thereon positioned relative to the base side members.

FIG. 18 is a front elevation view similar to FIG. 16 illustrating removal of the base side members.

FIG. 19 is a perspective view illustrating an assembled packaging system in accordance with an embodiment of the invention.

FIGS. 20-23 are perspective views similar to FIG. 19 illustrating the sequential disassembly of the packaging system relative to the freestanding device positioned therein.

FIG. 24a-24h are top views illustrating sequential removal of the base center deck relative to the freestanding device legs in accordance with an exemplary embodiment of the invention.

DETAILED DESCRIPTION OF THE INVENTION

In the drawings, like numerals indicate like elements throughout. Certain terminology is used herein for convenience only and is not to be taken as a limitation on the present invention. For example, the terms front, back, left and right are utilized herein to assist with understanding of relative positioning, but are not intended to be limiting to an orientation of use of the device. The following describes a preferred embodiment of the present invention. However, it should be understood, based on this disclosure, that the invention is not limited by the preferred embodiment described herein.

Referring to FIGS. 1-4, an exemplary embodiment of a packaging system 100 is shown positioned relative to exemplary freestanding devices 10, 10'. The packaging system 100 of the present embodiment generally includes a base structure 110, a cover member 160 and a pair of straps 190. In the illustrated assembled condition, the freestanding device 10, 10' is positioned with its legs (not shown) positioned within the base structure 110 and the cover member 160 is positioned on top of the housing 12, 12'. As shown, the housings 12, 12' may have varying configurations, with the base structure 110 and the cover member 160 configured to correspond to the specific housing 12, 12' structure. The straps 190 extend about the base structure 110 and the cover member 160 and secure them as a unit in the assembled condition. As illustrated in FIGS. 1-4, the housing 12, 12' preferably has a length and width less than that of the base structure 110 and cover member 160 such that the housing 12, 12' is recessed from the edges of the packaging system 100, thereby protecting the device 10, 10' from bumps or the like during transport. As illustrated in FIGS. 20-23, wall structures 180 may also be utilized to further protect the devices 10, 10' as described in more detail hereinafter.

Referring to FIGS. 5-8, an exemplary base center deck 112 will be described. The base center deck 112 includes side walls 113, 115 extending between a front wall 114 and a rear wall 116. A series of longitudinal and lateral ribs 117, 118 extend between the walls 113-116 to define the deck structure. A pair of strap guide slots 120 extend along the bottom surface of the deck 112 in the lateral direction. The rib structure is preferably manufactured from a polymeric material to provide a light weight yet sufficiently strong

structure, however, other materials may be utilized. Additionally, while the deck 112 is illustrated with an open rib structure, other structures, for example, a solid structure, a plank structure or a planar structure may be utilized. Similarly, while the exemplary deck 112 has a rectangular configuration, other configurations may be utilized.

A series of lugs 121a, 123a, 125a extend from the left side wall 113 and a series of lugs 121b, 123b, 125b extend from the right side wall 115. The lugs 121a, 123a, 125a are configured to be received in corresponding slots 141, 143, 145 in the left base side member 130a and the lugs 121b, 123b, 125b are configured to be received in corresponding slots 141, 143, 145 in the left base side member 130b as described in more detail below. The illustrated lugs 121, 123, 125 have a dovetail configuration, narrowing moving from the top surface of the deck 112 toward the bottom surface thereof, however, they may have other configurations. The lugs 121, 123, 125 have a height l which is preferably less than the height H of the deck 112. While lugs and corresponding receiving slots are described herein for releasably interconnecting the center deck 112 with the base members 130a, 130b, the invention is not limited to such and other releasable connection members, for example, clamps, screws, pegs, dowels or the like may be used.

As indicated in FIG. 8, the deck 112 has a width w between the side walls 113, 115 which is less than the overall width W of the deck 112. The overall width W of the deck 112 is equal to the width w plus the distance L the lugs 121-125a, 121-125b extend from the side walls 113, 115. In the illustrated embodiment, the front lugs 121a and 121b are longitudinally aligned while the mid lugs 123a and 123b are longitudinally offset and the rear lugs 125a and 125b are longitudinally offset. The relationship of the offsets and the widths w , W to the configuration of the device 10, 10' will be described with reference to FIGS. 5-8 and 24a-h.

FIG. 24a illustrates the longitudinal position of the deck 112 relative to the legs 14a, 14b of a freestanding device 10, 10' as the deck 112 would be positioned during transport. The legs 14a on one side of the device 10, 10' are laterally spaced from the legs 14b on the opposite side of the device 10, 10' by a distance D as indicated in FIG. 24h. In a preferred embodiment, the distance D is smaller than the total width W , but larger than the width w plus the distance l of one of the lugs 121, 123, 125. With such a configuration, including the lug offsets, the deck 112 provides as great as possible of a support width w while still being slidable in a longitudinal direction to be removed from between the legs 14a, 14b. Such slidability allows the center deck 112 to be removed with the legs 14a, 14b already positioned on a support surface, i.e., the housing 12, 12' does not have to be lifted to remove the center deck 112. Alternatively, the total width W can be made to be smaller than the distance D , whereby the deck 112 may be easily slid out from between the legs 14a, 14b, however, such a configuration reduces the support width w of the center deck 112. It is noted that since the forward lugs 121a, 121b are already forward of the front legs 14a, 14b, the lugs 121a, 121b of the illustrated embodiment are longitudinally aligned without concern for passage between the legs 14a, 14b.

Removal of the illustrated center deck 112 will be described with reference to FIGS. 24a-24h. In the initial step illustrated in FIG. 24a, the deck 112 is moved laterally such that the side 113 contacts the legs 14a. In this position, the opposite lugs 123b and 125b are laterally clear of the legs 14b. The deck 112 is moved forward as indicated by the arrow in FIG. 24b until the mid lug 123a contacts the forward leg 14a. The deck 112 is then moved laterally as

indicated by the arrow in FIG. 24c until the side 115 contacts the legs 14b. In this position, the opposite lugs 123a and 125a are laterally clear of the legs 14a. The deck 112 is moved forward as indicated by the arrow in FIG. 24d until the mid lug 123b contacts the forward leg 14b, with the lug 123a clearing the legs 14a. The deck 112 is then moved laterally as indicated by the arrow in FIG. 24e such that the side 113 contacts the legs 14a. In this position, the opposite lugs 123b and 125b are laterally clear of the legs 14b. The deck 112 is moved forward as indicated by the arrow in FIG. 24f until the rear lug 125a contacts the forward leg 14a, with the lug 123b clearing the legs 14b. The deck 112 is then moved laterally as indicated by the arrow in FIG. 24g until the side 115 contacts the legs 14b. In this position, the opposite lug 125a is laterally clear of the legs 14a. The deck 112 is moved forward as indicated by the arrow in FIG. 24h until the rear lug 125b contacts the forward leg 14b, with the lug 125a clearing the legs 14a. With one last lateral movement and forward movement (not shown), the lug 125b is clear of the legs 14b and the center deck 112 is removed. The center deck 112 is positioned under a device by reversing this procedure.

Referring to FIGS. 9-15, the base side members 130 and the interconnection of the center deck 112 therewith will be described. FIGS. 9-12 show the right base side member 130a, with the left base side member 130b preferably being a mirror image thereof. The base side member 130 includes a support member 132 extending longitudinally from front to back. The support member 123 is supported by a front base leg 134 and a rear base leg 136 with a longitudinal space 133 therebetween. A bridge portion 131 of the support member 132 bridges between the legs 134, 136 over the longitudinal space 133. Support strap slots 140 extend laterally along the lower surface of the bridge portion 131 and are configured to longitudinally align with the strap slots 120 of the base center deck 112. The bridge portion 131 preferably has a height h which is equal to a height H of the deck 112 to further align the slots 120, 140. An upper wall 138 extends upward from the support member 132 along the side and rear edges thereof. The slots 140 may extend along the outer surface of the wall 138. As illustrated in FIG. 12, the support member 132, the base legs 134, 136 and the wall 138 are supported by a series of lateral and longitudinal ribs 148, 149. Again, while a rib structure is defined, the invention is not limited to such.

Each base side member 130 includes a series of lug receiving slots 141, 143, 145 defined along the support member 132. The slots 141, 143, 145 are longitudinally positioned such that they align with and receive the respective lugs 121a, 123a, 125a or 121b, 123b, 125b. The illustrated slots 141, 143, 145 have a dovetail configuration corresponding to that of the lugs 121, 123, 125, however, they may have other configurations. The slots 141, 143, 145 have a depth such that the lugs 121, 123, 125 are received and stopped with the upper surface of the center deck 112 flush with the upper surface of the support member 132.

A pair of leg receiving openings 135 and 137 are defined into the support member 132. Each opening 135, 137 is preferably longitudinally positioned within a respective leg 134, 136 such that legs 14 received in the openings 135, 137 remain clear of the base side member longitudinal space 133. The openings 135, 137 are preferably tapered inward to assist in guiding the legs 14 into the openings 135, 137 which also assists in aligning the lugs 121, 123, 125 with the respective slots 141, 143, 145. As illustrated in FIGS. 13 and 14, the center deck 112 is preferably positioned under the device housing 12, 12' and lifted using a pallet jack or the

like. The base side members 130a, 130b are moved into position relative to the raised housing 12, 12' and legs 14. The upper wall 138 may contact the legs 14 to provide an initial macro positioning. As the center deck 112 is lowered, the legs 14 enter the openings 135, 137 with the taper of the openings 135, 137 causing the base side members 130a, 130b to move into a more precise alignment. As the deck 112 is continued to be lowered, the dovetail configuration of the slots 141, 143, 145 and the corresponding lugs 121, 123, 125 guide the deck 112 into final mating position with the base side members 130a, 130b. The deck 112 is lowered until the lugs 121, 123, 125 are fully received in the slots 141, 143, 145 as illustrated in FIG. 14. The openings 135, 137 preferably have a depth approximately equal to the height of the legs 14 such that the legs 14 contact the bottom of the openings 135, 137 at the same time the housing 12, 12' contacts the upper surface of the deck 112 and support members 132. The base structure 110 is thereby fully assembled with a lateral space 153 between the base side members 130a, 130b.

In this configuration, the device 10, 10' may be moved by positioning a pallet jack or the like laterally through the longitudinal opening 133, however, it is preferred that the cover member 160 is secured with the straps 190 before movement. To remove the base structure 110 from the device 10, 10', a pallet jack or the like is positioned longitudinally through the lateral opening 153 and the center deck 112 is lifted until the legs 14 clear the openings 135, 137, at which point the lugs 121, 123, 125 have already cleared the slots 141, 143, 145, and the base side members 130a, 130b are removed as indicated in FIG. 15. The center deck 112 is then lowered and removed in the manner described with reference to FIGS. 24a-24h.

Referring to FIGS. 9-11, the base side members 130a, 130b preferably define a wall receiving configuration. In this regard, an inner wall guide 146 extends upward from the bridge portion 131 opposite the upper wall 138 such that a wall receiving slot 139 is defined therebetween. A lower portion of a wall 180, see FIG. 21, is received within the slot 139 and the inner wall guide 146 prevents the wall 180 from pressing against the device housing 12, 12' when the straps 190 are attached.

Referring to FIGS. 13-15, the base side members 130 may be provided with shock dampeners 151 along the lower surface of each base leg 134, 136. Holes 147 may be provided in each base leg 134, 136 for securing the dampeners 151, although other connection mechanisms may be utilized. The shock dampeners 151 have an elastomeric structure which helps to reduce shock and vibration experienced by the device 10, 10' when being transported. The shock dampeners 151 may have various configurations, for example, they may be solid structures manufactured from an elastomeric material or fluid filled which is either sealed or fillable. Referring to FIGS. 9-11, in the illustrated embodiment, the upper wall 138 includes recesses 142, 144 configured to receive the shock dampeners 151 of a base side member 130 which may be stacked thereon, for example, during storage.

Referring to FIGS. 16-18, an exemplary cover member 160 will be described. The exemplary cover member 160 includes a planar portion 162 with a raised center portion 163. The raised center portion 163 defines a concave internal space 165 configured to receive the upper portion of the device housing 12, 12'. The raised center portion 163 may have a stepped configuration to facilitate use with different housing configurations. A pair of strap slots 170 extend

laterally across the raised center portion **163** and are positioned to align with the strap slots **120**, **140** upon assembly.

A rim **164** depends from the perimeter of the planar portion **162**, with the lateral sides of the rim **164** defining an extended portion **166**. Inside the extended portion **166**, a number of wall projections **168** extend from the inside surface of the planar portion **162** such that a wall receiving slot **169** is defined between the projections **168** and the inside surface of the extended portion **166**. An upper portion of the wall **180**, see FIG. **21**, is received within the slot **169**.

When a freestanding device **10**, **10'** is ready for transport, the device is first positioned with respect to the base structure **110** as described with reference to FIGS. **13** and **14**. If utilized, the wall **180** is positioned such that the lower portion of the wall **180** is received in the slots **139** defined by the base side members **130**. The cover member **160** is then positioned on top of the device housing **12**, **12'** with the upper portion thereof received in the concave internal space **165** and the upper portion of the wall **180** is received within the slot **169**. Straps **190** are secured around the base structure **110** and the cover member **160**, received in the respective slots **120**, **140**, **170**. The freestanding device is thereby secured within the packaging system **100** as illustrated in FIG. **19**. The device can be delivered with reduced chance of damage and can be moved proximate to its final use location via a pallet jack positioned through the lateral space **153**.

Once delivered, the freestanding device **10**, **10'** may be easily unpacked from the packaging system **100** in the manner illustrated in FIGS. **20-23**. First, as illustrated in FIG. **20**, the straps **190** are released, for example, by cutting which allows the cover member **160** to be lifted off and the walls **180** lifted out of the slots **139** in the base side members **130**. The walls **180** are then separated and removed as illustrated in FIG. **21**. The freestanding device **10** is simply supported by the base structure **110**. A pallet jack or the like is then used to lift the center deck **112** as previously described with reference to FIG. **15**. Once the legs **14** clear, the base side members **130** are easily removed and the device **10** lowered until the legs **14** are on the floor as illustrated in FIG. **22**. Referring to FIG. **23**, the center deck **112** is then removed. The process described with reference to FIGS. **24a-24h** may be utilized if necessary. The device **10** is easily unpackaged without any tools other than a tool used to remove the straps **190**.

These and other advantages of the present invention will be apparent to those skilled in the art from the foregoing

specification. Accordingly, it will be recognized by those skilled in the art that changes or modifications may be made to the above-described embodiments without departing from the broad inventive concepts of the invention. It should therefore be understood that this invention is not limited to the particular embodiments described herein, but is intended to include all changes and modifications that are within the scope and spirit of the invention as defined in the claims.

What is claimed is:

1. A method of packaging a free standing machine, the machine comprising a housing supported on a plurality of spaced apart legs such that a lower housing surface is supported spaced from a ground surface upon which the legs are supported, the method comprising:

positioning a center deck below the lower housing surface between the machine legs, the center deck having a support surface extending between opposed sides;

raising the center deck such that the center deck contacts the lower housing surface and raises the housing until the machine legs are spaced from the ground surface;

aligning a base side member adjacent each of the center deck opposed sides, each base side member having first and second spaced apart base legs and a support member extending between the base legs;

lowering the center deck until the center deck support surface is aligned with an upper surface of each support member to define a planar pallet surface; and

releasably connecting each base side member to the center deck such that the relative position of the center deck support surface to the upper surface of each support member is maintained and the machine legs are maintained spaced from the ground surface.

2. The method of claim **1** wherein each support member defines one or more machine leg receiving openings and during the lowering step, each of the machine legs is received in a respective machine leg receiving opening.

3. The method of claim **1** further comprising:

positioning a cover on a top surface of the machine housing; and

securing at least one strap about the cover, the center deck and each base side member.

4. The method of claim **3** further comprising positioning a wall system between the cover and the base side members before securing the at least one strap.

* * * * *