



US010029679B2

(12) **United States Patent**
Nava

(10) **Patent No.:** **US 10,029,679 B2**
(45) **Date of Patent:** **Jul. 24, 2018**

(54) **CONTROLLING SKIDDING VEHICLES**

USPC 701/41
See application file for complete search history.

(71) Applicant: **Ford Global Technologies, LLC**,
Dearborn, MI (US)

(56) **References Cited**

(72) Inventor: **Ivan Nava**, Metepec (MX)

U.S. PATENT DOCUMENTS

(73) Assignee: **FORD GLOBAL TECHNOLOGIES, LLC**, Dearborn, MI (US)

5,058,018 A * 10/1991 Kuwana B60T 8/1764
303/149

(*) Notice: Subject to any disclaimer, the term of this patent is extended or adjusted under 35 U.S.C. 154(b) by 9 days.

5,089,967 A 2/1992 Haseda
7,374,014 B2 5/2008 Yasui
(Continued)

FOREIGN PATENT DOCUMENTS

(21) Appl. No.: **15/232,124**

WO WO-2014148979 A1 9/2014
WO WO-2016035665 A1 3/2016

(22) Filed: **Aug. 9, 2016**

(65) **Prior Publication Data**

OTHER PUBLICATIONS

US 2018/0043883 A1 Feb. 15, 2018

Interview: Talking Autonomous Cars and Driver-Assist Advances With Ford's Greg Stevens, Feb. 2, 2016, by Mark Lelinwalla Tech Times.

(51) **Int. Cl.**
B60W 30/045 (2012.01)
G05D 1/00 (2006.01)
G05D 3/20 (2006.01)
G08G 1/16 (2006.01)

Primary Examiner — Atul Trivedi
(74) *Attorney, Agent, or Firm* — David R. Stevens;
Stevens Law Group

(Continued)

(52) **U.S. Cl.**
CPC **B60W 30/045** (2013.01); **G05D 1/0061** (2013.01); **G05D 1/0223** (2013.01); **G05D 1/0236** (2013.01); **G05D 3/206** (2013.01); **G05D 13/62** (2013.01); **G08G 1/166** (2013.01); **B60W 2420/52** (2013.01); **B60W 2520/26** (2013.01); **B60W 2540/04** (2013.01); **B60W 2550/00** (2013.01); **B60W 2710/18** (2013.01); **B60W 2720/106** (2013.01); **B60W 2720/125** (2013.01); **B60W 2720/24** (2013.01)

(57) **ABSTRACT**
The present invention extends to methods, systems, and computer program products for controlling skidding vehicles. In general, a vehicle adjusts its configuration to mitigate the skidding. The vehicle can recognize dynamic skid situations and apply strategies to avoid an accident. In response to a signal that a vehicle is in a specified type of skid, the vehicle's configuration can be automatically changed to recover from the skid. Different configuration changes can be used to recover from different skid types, including: oversteer, understeer and counter steer. Changing vehicle configuration can include utilizing vehicle systems such as, for example, steering, braking, cruise control, lane keeping, etc.

(58) **Field of Classification Search**
CPC B60W 30/045; B60W 2420/52; B60W 2520/26; B60W 2540/04; B60W 2550/00; B60W 270/18; B60W 2720/106; B60W 2720/125; B60W 2720/24; G05D 1/0061; G05D 1/0223; G05D 1/0236; G05D 3/206; G05D 13/62; G08G 1/166

15 Claims, 6 Drawing Sheets

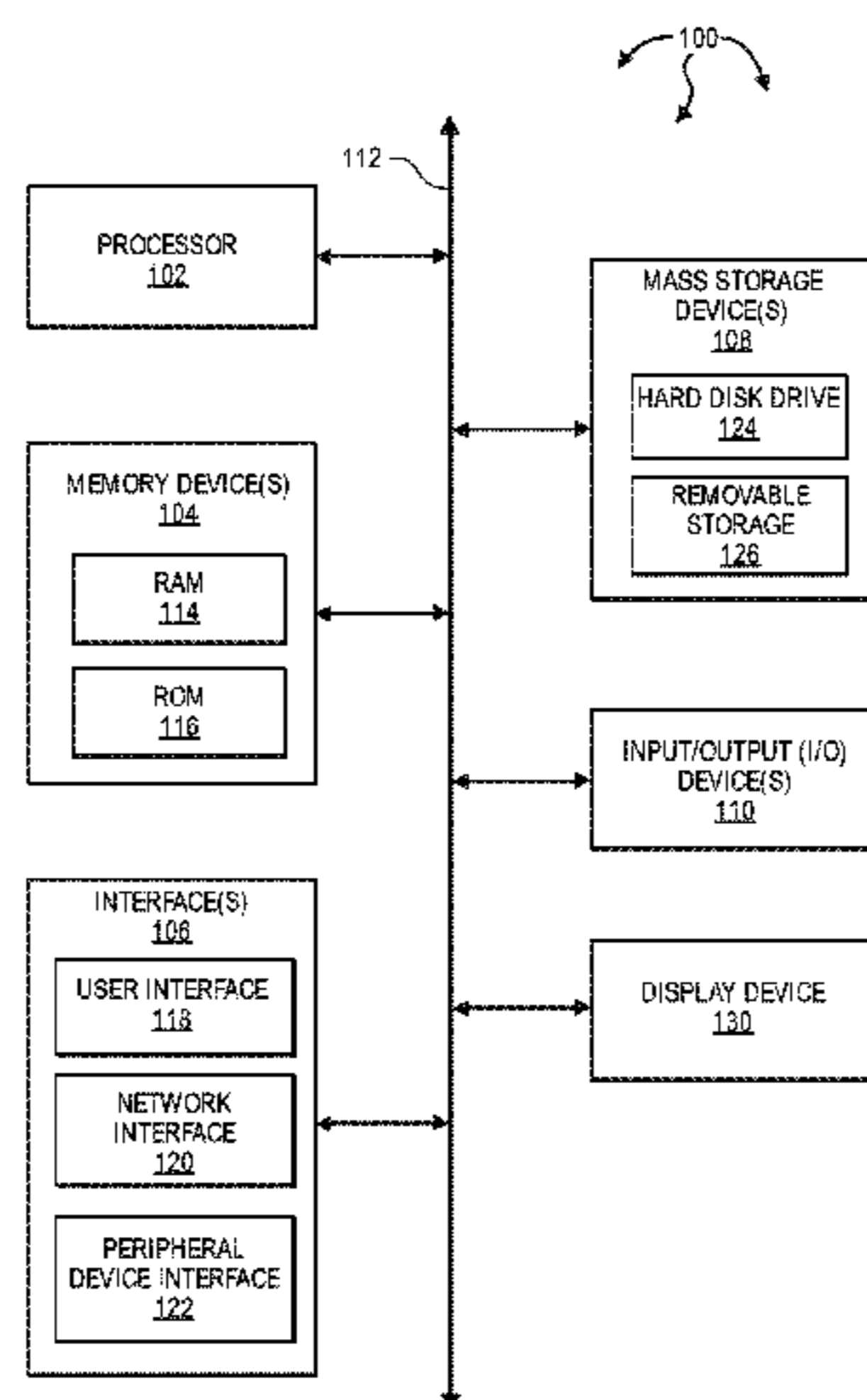

- (51) **Int. Cl.**
G05D 1/02 (2006.01)
G05D 13/62 (2006.01)

(56) **References Cited**

U.S. PATENT DOCUMENTS

8,521,349	B2	8/2013	Yu	
8,554,414	B2 *	10/2013	Koto B60T 8/17554 280/5.5
2006/0265114	A1 *	11/2006	Thumrugoti B60T 8/17554 701/71
2010/0106374	A1 *	4/2010	Miyajima B60T 8/1755 701/41
2011/0202241	A1 *	8/2011	Le B60R 21/0134 701/46
2011/0241299	A1 *	10/2011	Harada B60T 8/1755 280/5.513
2014/0022070	A1 *	1/2014	Golomb B60Q 1/0082 340/475
2015/0224845	A1 *	8/2015	Anderson B60G 17/019 701/37

* cited by examiner

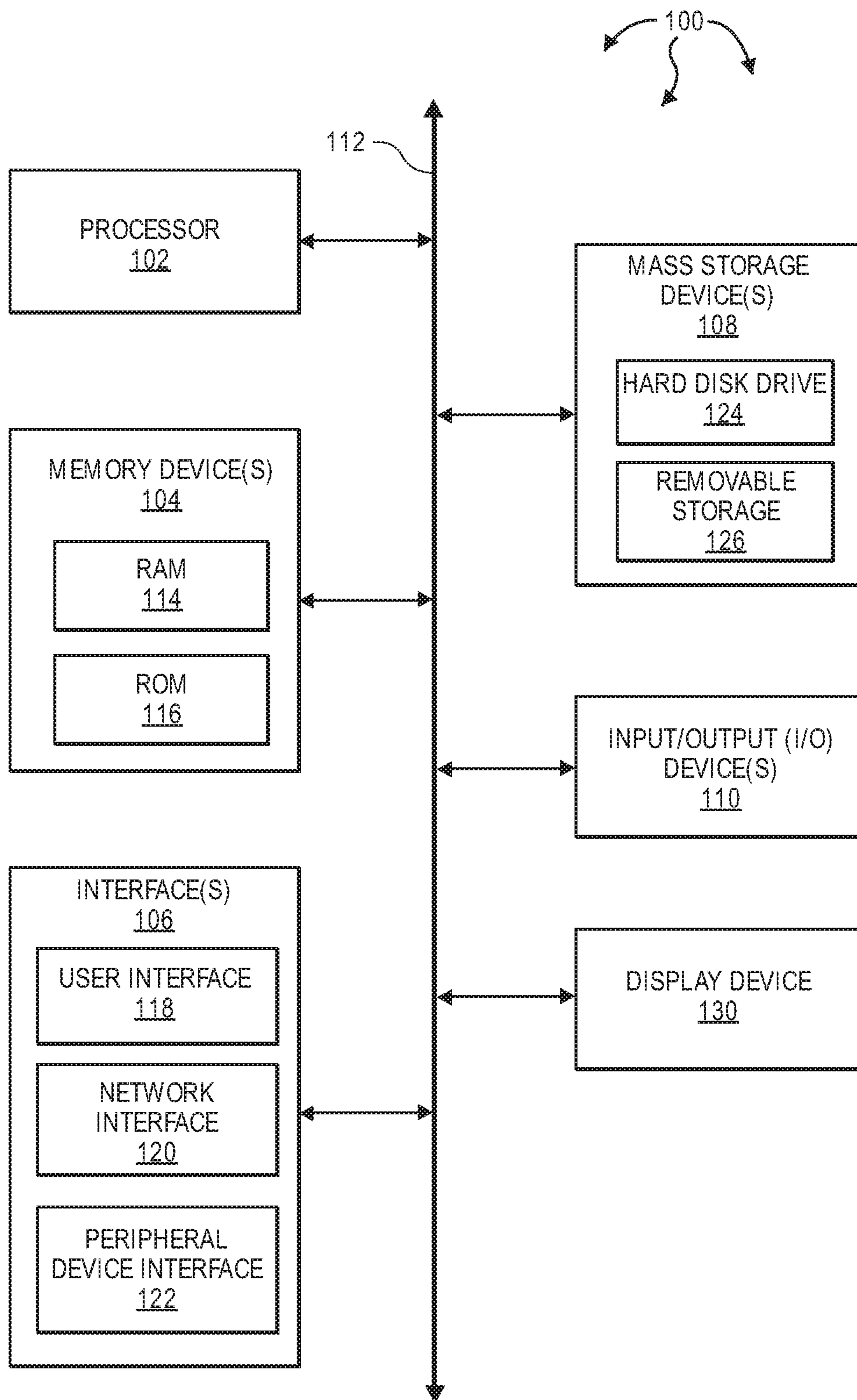

FIG. 1

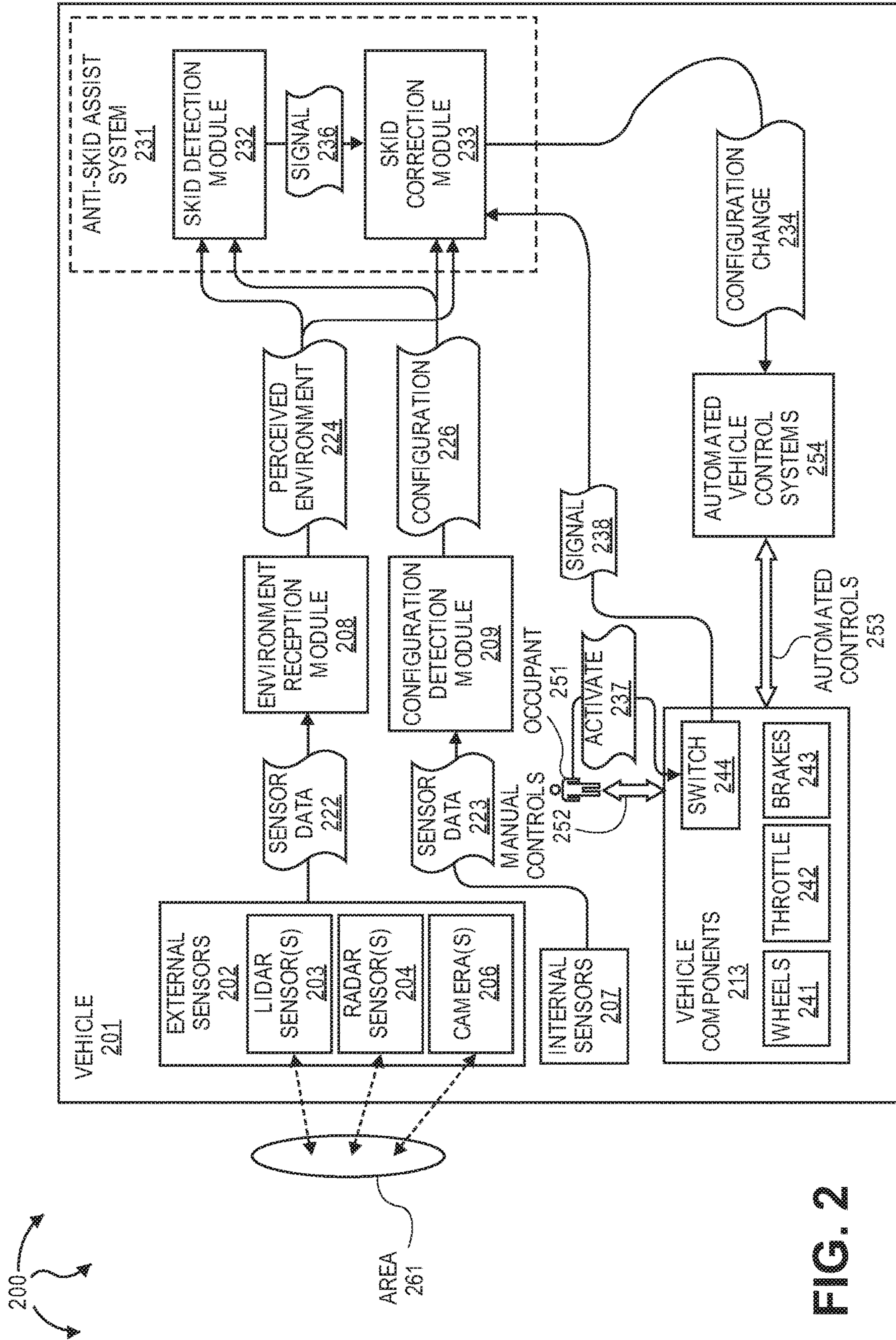

FIG. 2

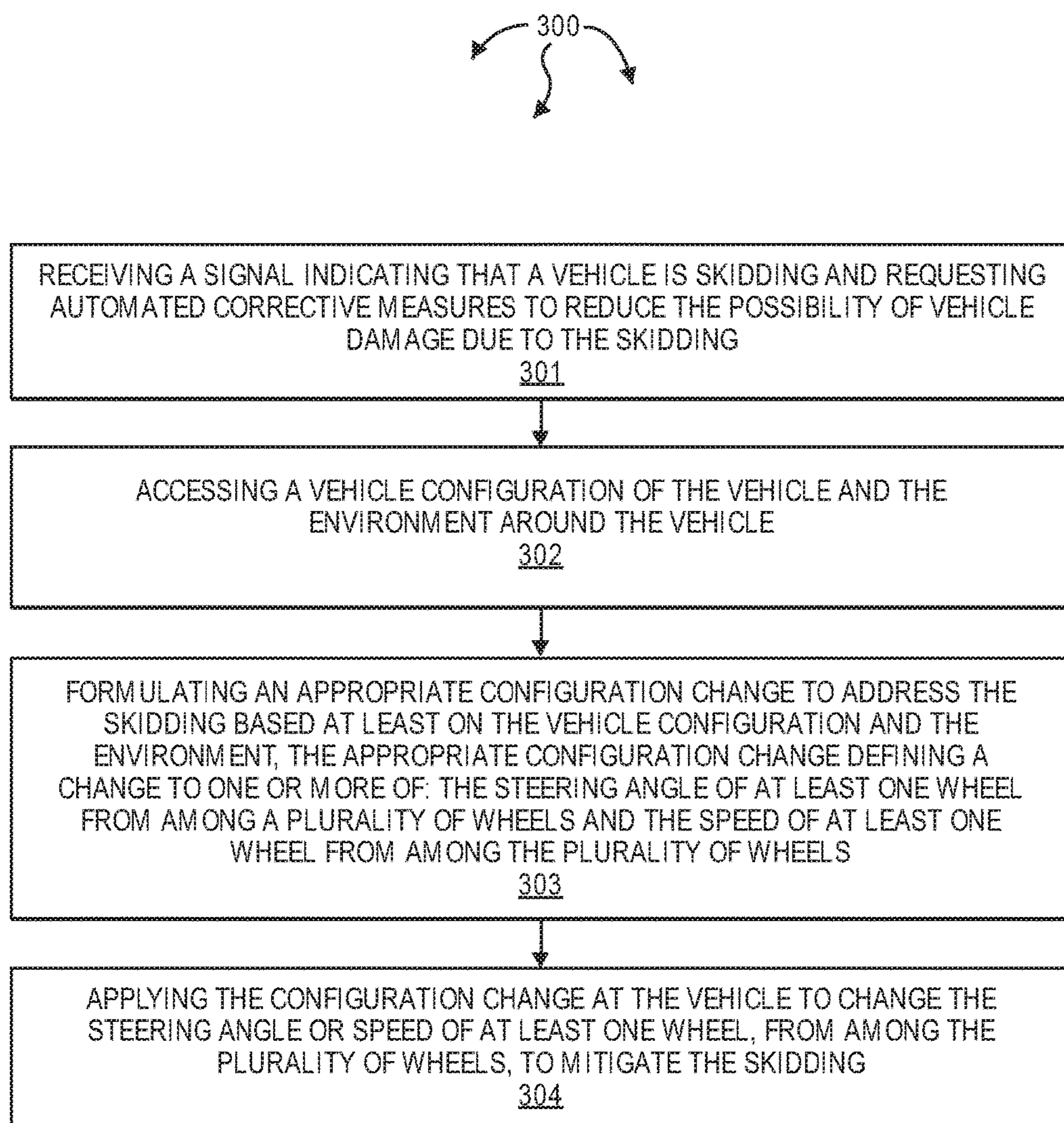
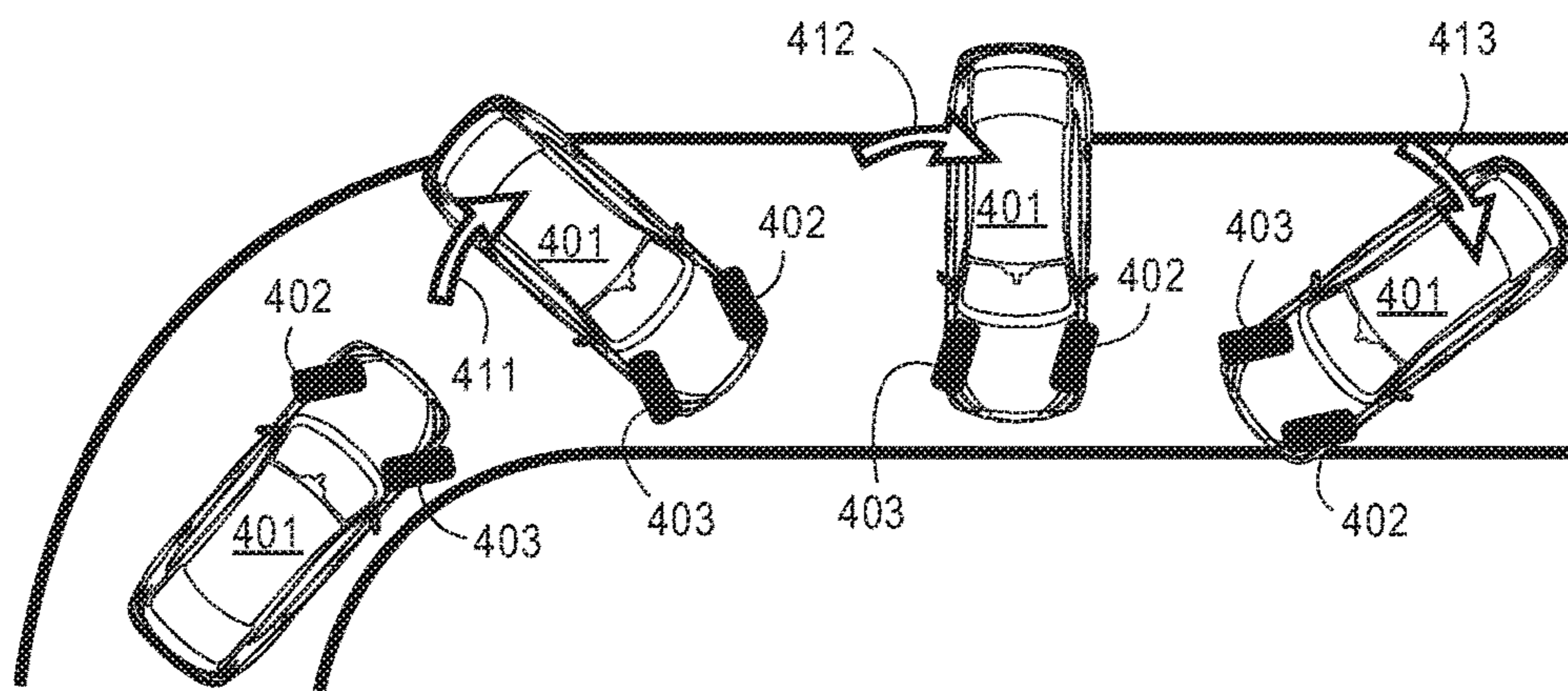

FIG. 3



(OVERSTEER)

FIG. 4A

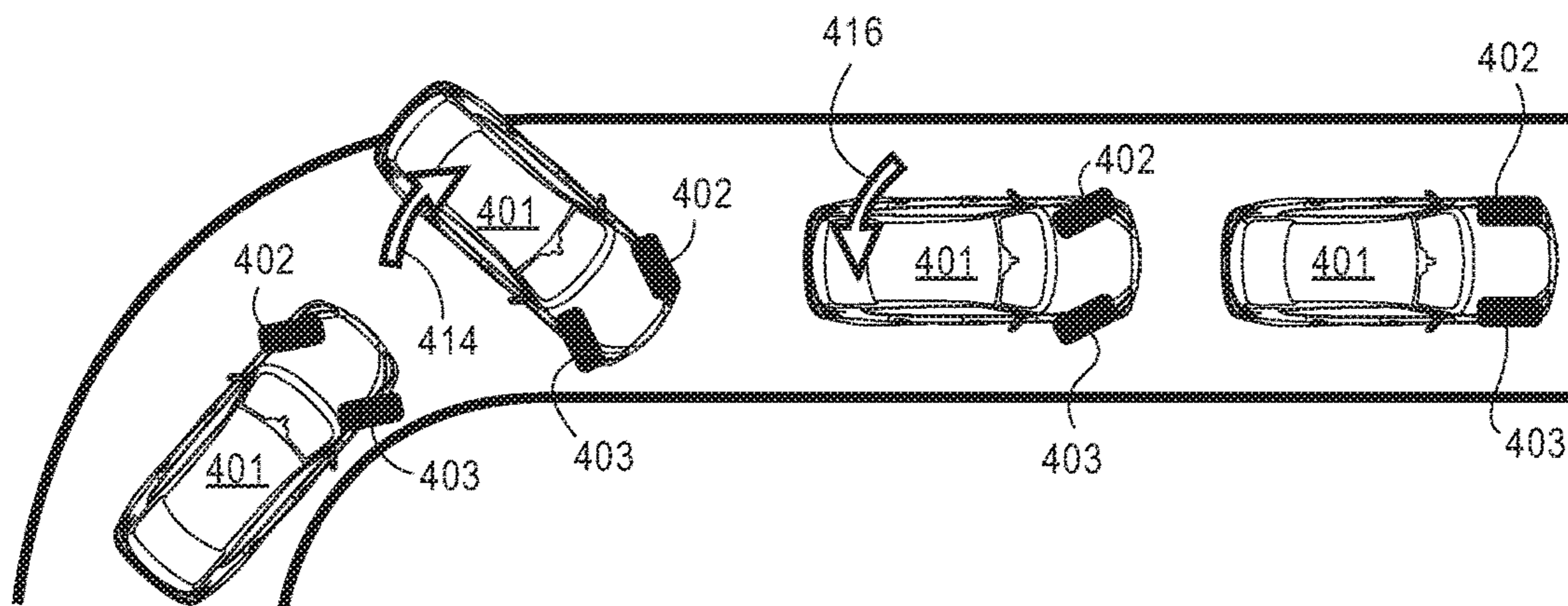
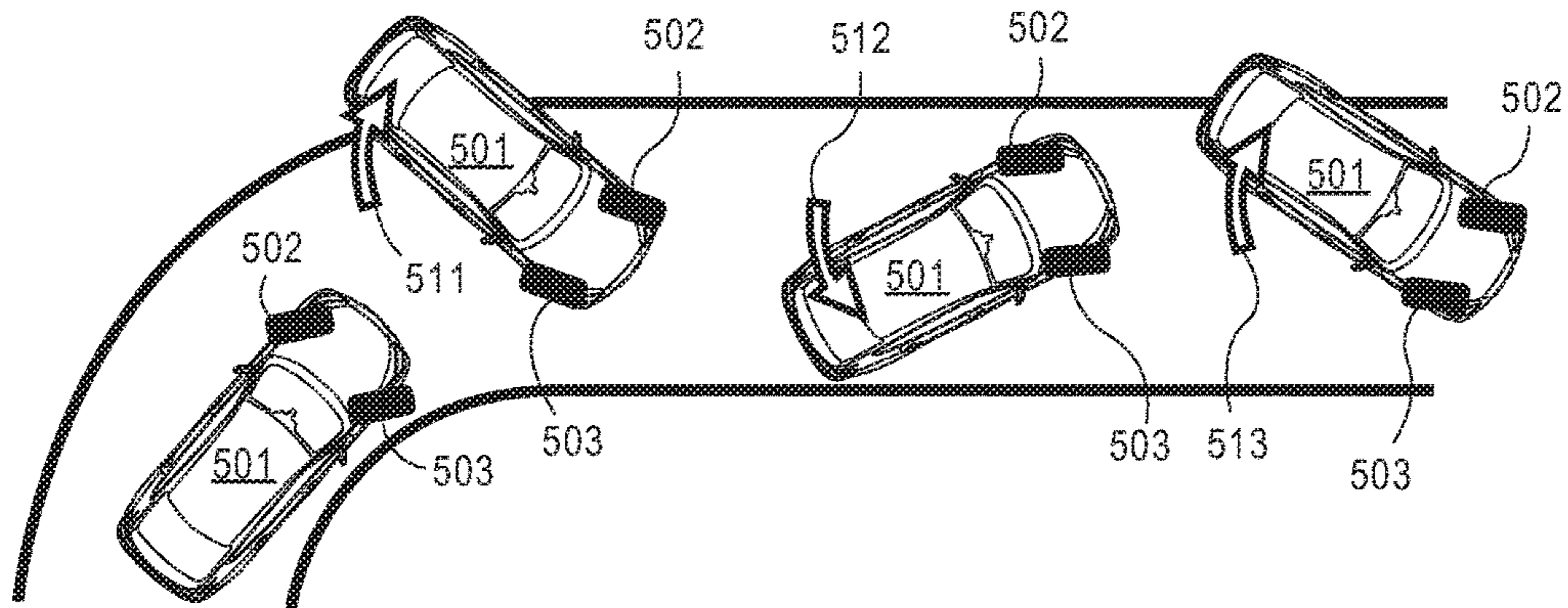

FIG. 4B



(FISHTAIL)

FIG. 5A

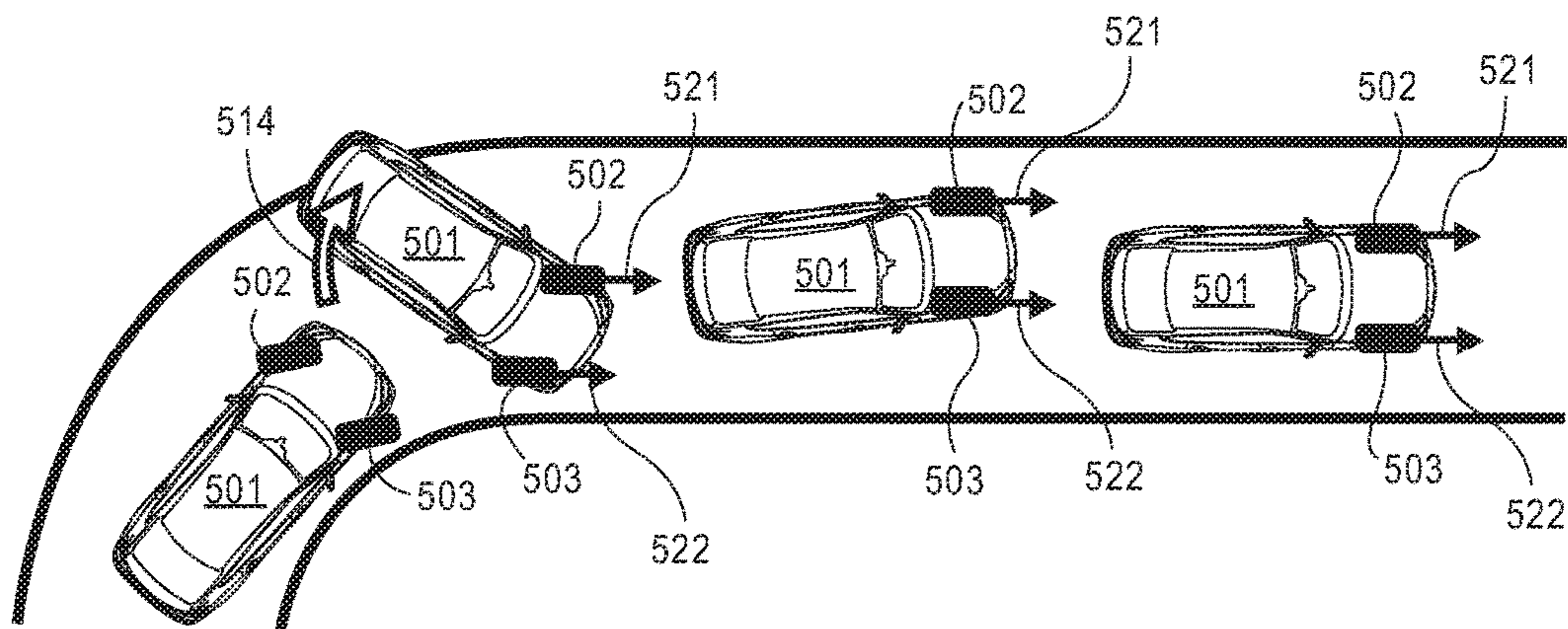
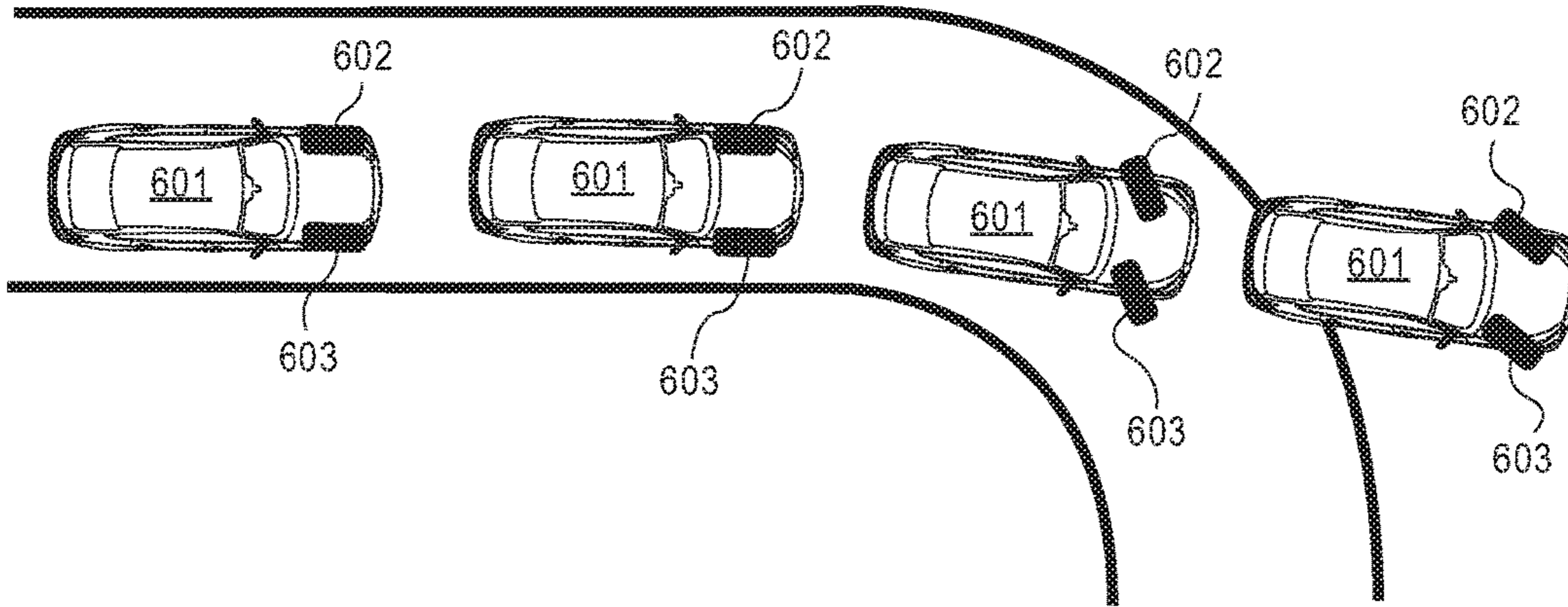

FIG. 5B



(UNDERSTEER)

FIG. 6A

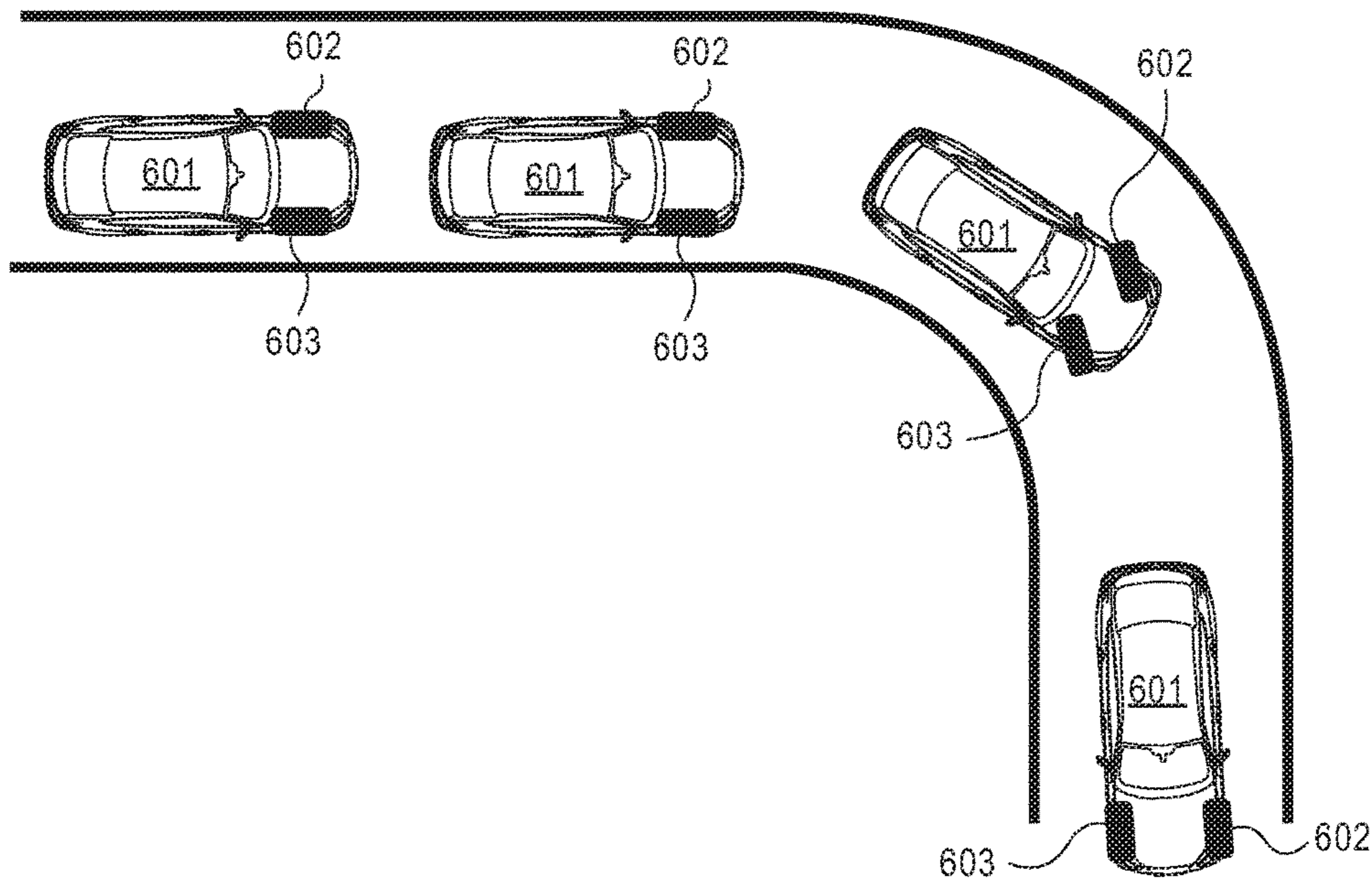

FIG. 6B

CONTROLLING SKIDDING VEHICLESCROSS-REFERENCE TO RELATED
APPLICATIONS

Not applicable.

BACKGROUND

1. Field of the Invention

This invention relates generally to the field of antiskid systems, and, more particularly, to controlling skidding vehicles.

2. Related Art

Accidents due to vehicle skidding are common. Skidding can occur under a variety of circumstances including when a driver oversteers or understeers going into a corner. Road conditions can also contribute to vehicle skidding. For example, vehicles are more susceptible to skidding in winter driving conditions where snow reduces visibility and ice makes roads slippery. Many drivers lack the necessary skills to properly handle vehicle skidding.

BRIEF DESCRIPTION OF THE DRAWINGS

The specific features, aspects and advantages of the present invention will become better understood with regard to the following description and accompanying drawings where:

FIG. 1 illustrates an example block diagram of a computing device.

FIG. 2 illustrates an example environment that facilitates controlling a skidding vehicle.

FIG. 3 illustrates a flow chart of an example method for controlling a skidding vehicle.

FIGS. 4A and 4B illustrate an example of an unmitigated oversteer skid and a corresponding mitigated oversteer skid.

FIGS. 5A and 5B illustrate an example of an unmitigated counter steer skid (fishtail) and a corresponding mitigated counter steer skid.

FIGS. 6A and 6B illustrate an example of an unmitigated understeer skid and a corresponding mitigated understeer skid.

DETAILED DESCRIPTION

The present invention extends to methods, systems, and computer program products for controlling skidding vehicles.

In general, a vehicle adjusts its configuration to mitigate the skidding. In one aspect, a vehicle is equipped with a trigger on the steering wheel (or other adjacent location in the vehicle's cabin). The trigger allows the driver to manually pass control to the vehicle so that the vehicle can take automated measures to attempt (self) recovery from a skid. A driver can activate the trigger when he or she is unable to recover from a skid (e.g., lacks the driving skill) and/or when he or she simply desires for the vehicle handle a skid (even if the driver has the driving skill to regain control). In another aspect, the vehicle automatically detects when a skid is potentially uncontrollable and then takes automated measures to attempt (self) recovery from the skid.

The two mechanisms can also operate together. A vehicle can automatically detect a skid. The vehicle can allow some

amount of time for the driver to correct the skid. If after a specified amount of time the skid is not corrected and/if the skid becomes more dangerous, the vehicle can take automated measures to attempt (self) recovery from the skid. At any time before the vehicle automatically takes over, the driver can activate the trigger to manually pass control to the vehicle. In response to trigger activation, the vehicle can take automated measures to attempt (self) recovery from the skid.

Automated mechanisms for skid recovery can include using various sensors, including LIDAR, to evaluate the vehicle's current configuration (e.g., acceleration, speed, wheel angles, etc.) and environment. Some of the sensors can sense out to a range of up to 200 meters, providing a relatively substantial view on the vehicle's environment (e.g., obstacles, other vehicles, pedestrians, lane lines, etc.). Depending on the vehicle's current configuration and environment, the vehicle's configuration can be automatically changed to recover from a skid.

In one aspect, the vehicle detects a type of skid, such as, an oversteer skid, a counter steer skid, or an understeer skid. Based on the detected skid type, the vehicle's configuration can be automatically changed to recover from a skid. Different configuration changes can be used to recover from different skid types. Changing configuration can include utilizing other vehicle systems such as, for example, steering, braking, cruise control, lane keeping, etc.

Accordingly, a vehicle can recognize dynamic skid situations and automatically apply strategies to avoid an accident.

Aspects of the invention can be implemented in a variety of different types of computing devices. FIG. 1 illustrates an example block diagram of a computing device **100**. Computing device **100** can be used to perform various procedures, such as those discussed herein. Computing device **100** can function as a server, a client, or any other computing entity. Computing device **100** can perform various communication and data transfer functions as described herein and can execute one or more application programs, such as the application programs described herein. Computing device **100** can be any of a wide variety of computing devices, such as a mobile telephone or other mobile device, a desktop computer, a notebook computer, a server computer, a handheld computer, tablet computer and the like.

Computing device **100** includes one or more processor(s) **102**, one or more memory device(s) **104**, one or more interface(s) **106**, one or more mass storage device(s) **108**, one or more Input/Output (I/O) device(s) **110**, and a display device **130** all of which are coupled to a bus **112**. Processor(s) **102** include one or more processors or controllers that execute instructions stored in memory device(s) **104** and/or mass storage device(s) **108**. Processor(s) **102** may also include various types of computer storage media, such as cache memory.

Memory device(s) **104** include various computer storage media, such as volatile memory (e.g., random access memory (RAM) **114**) and/or nonvolatile memory (e.g., read-only memory (ROM) **116**). Memory device(s) **104** may also include rewritable ROM, such as Flash memory.

Mass storage device(s) **108** include various computer storage media, such as magnetic tapes, magnetic disks, optical disks, solid state memory (e.g., Flash memory), and so forth. As depicted in FIG. 1, a particular mass storage device is a hard disk drive **124**. Various drives may also be included in mass storage device(s) **108** to enable reading

from and/or writing to the various computer readable media. Mass storage device(s) **108** include removable media **126** and/or non-removable media.

I/O device(s) **110** include various devices that allow data and/or other information to be input to or retrieved from computing device **100**. Example I/O device(s) **110** include cursor control devices, keyboards, keypads, barcode scanners, microphones, monitors or other display devices, speakers, printers, network interface cards, modems, cameras, lenses, radars, CCDs or other image capture devices, and the like.

Display device **130** includes any type of device capable of displaying information to one or more users of computing device **100**. Examples of display device **130** include a monitor, display terminal, video projection device, and the like.

Interface(s) **106** include various interfaces that allow computing device **100** to interact with other systems, devices, or computing environments as well as humans. Example interface(s) **106** can include any number of different network interfaces **120**, such as interfaces to personal area networks (PANs), local area networks (LANs), wide area networks (WANs), wireless networks (e.g., near field communication (NFC), Bluetooth, Wi-Fi, etc., networks), and the Internet. Other interfaces include user interface **118** and peripheral device interface **122**.

Bus **112** allows processor(s) **102**, memory device(s) **104**, interface(s) **106**, mass storage device(s) **108**, and I/O device(s) **110** to communicate with one another, as well as other devices or components coupled to bus **112**. Bus **112** represents one or more of several types of bus structures, such as a system bus, PCI bus, IEEE 1394 bus, USB bus, and so forth.

FIG. 2 illustrates an example environment **200** that facilitates automatically controlling skidding vehicles. Environment **200** includes vehicle **201**, such as, for example, a car, a truck, or a bus. Vehicle **201** can contain one or more occupants, such as, for example, occupant **251** (which may be a driver or passenger). Environment **200** also includes area **261**. Area **261** can be an area around vehicle **201**. Area **261** can include roadway markings (e.g., lane boundaries), pedestrians, other vehicles, signs, or any other types of objects.

Vehicle **201** includes external sensors **202**, internal sensors **207**, environment perception module **208**, configuration detection module **209**, vehicle components **213**, anti-skid assist system **231**, and automated vehicle control systems **254**.

External sensors **202** include one or more of: LIDAR sensors **203**, radar sensor(s) **204**, and camera(s) **206**. External sensors **202** may also include other types of sensors (not shown), such as, for example, acoustic sensors, ultrasonic sensors, and electromagnetic sensors. In general, external sensors **202** can sense and/or monitor objects in area **261**. External sensors **202** can output sensor data **222** indicating the position and optical flow (i.e., direction and speed) of monitored objects.

From the sensor data **222**, environment perception module **208** can perceive an environment in area **261**. Perception module **208** can receive sensor data for objects within area **261**. Perception module **208** can process the sensor data to identify objects of interest within area **261**. Perception module **208** can use one or more perception algorithms to classify objects. Object classifications can include: lane boundaries, cross-walks, signs, control signals, cars, trucks, pedestrians, etc. Some object classifications can have sub-classifications. For example, a sign can be classified by sign

type, such as, a stop sign, a yield sign, a school zone sign, a speed limit sign, etc. Perception module **208** can also determine the location of an object within area **261**. If an object is moving, perception neural network module **208** can also determine a likely path of the object.

In one aspect, perception module **208** includes a neural network architected in accordance with a multi-layer (or “deep”) model. A multi-layer neural network model can include an input layer, a plurality of hidden layers, and an output layer. A multi-layer neural network model may also include a loss layer. For classification of sensor data (e.g., an image), values in the sensor data (e.g., pixel-values) are assigned to input nodes and then fed through the plurality of hidden layers of the neural network. The plurality of hidden layers can perform a number of non-linear transformations. At the end of the transformations, an output node yields a perceived environment for objects within area **261**.

Vehicle components **213** includes components of vehicle **201**, such as, for example, wheels **241**, throttle **242**, brakes **243**, switch **244**, etc. For a car or truck, wheels **241** can include four or more wheels. Each wheel can have an attached tire that contacts the road surface. Vehicle components **213** can also include any of a plurality of other components found in vehicles, such as, for example, an engine, a transmission, exhaust, a battery (and other electrical system components), environmental control components, media system components, etc. In one aspect, switch **244** is a manually activated trigger (e.g., on a steering wheel) for passing control of the vehicle from occupant **251** to vehicle **201**.

In general, internal sensors **207** are configured to monitor vehicle components **213**. Internal sensors **207** can output sensor data **223** indicating settings for each of vehicle components **213**. From the sensor data **223**, configuration detection module **209** can detect a configuration for vehicle **201**. A vehicle configuration can include vehicle acceleration/deceleration (via throttle **242**), vehicle speed, vehicle direction of travel, steering angle for each of wheels **241**, wheel rotation for each of wheels **241**, application of brakes **243**, etc.

Anti-skid assist system **231** includes skid detection module **232** and skid correction module **233**. Based on a perceived environment and vehicle configuration, skid detection module **232** can detect if vehicle **201** is skidding. When skidding is detected, skid detection module **232** can also can classify the type of skid (e.g., wheel lockup, understeer, oversteer, counter steer skid (fishtailing), etc.).

In one aspect, skid detection module **232** includes a neural network architected in accordance with a multi-layer (or “deep”) model. A multi-layer neural network model can include an input layer, a plurality of hidden layers, and an output layer. A multi-layer neural network model may also include a loss layer. For classification of a perceived environment and vehicle configuration, values in the perceived environment and vehicle configuration are assigned to input nodes and then fed through the plurality of hidden layers of the neural network. The plurality of hidden layers can perform a number of non-linear transformations. At the end of the transformations, an output node yields a value indicating whether or not vehicle **201** is skidding and, if so, the type of skid inferred by skid detection module **232**.

When skid detection module **232** detects that vehicle **201** is skidding, skid detection module **232** can send a signal **236** indicating the type of skid to skid correction module **233**. Skid correction module **233** can receive the signal **236** from skid detection module **232**.

Occupant **251** (e.g., a driver) can use manual controls **252** to control vehicle components **213** when driving. For example, occupant **251** can use an acceleration pedal to control throttle **242**, a steering wheel to control a steering angle for wheels **241**, and a brake pedal to control brakes **243**.

It may be that occupant **251** operates vehicle **201** in a manner that causes vehicle **201** to skid. If occupant **251** perceives recovery from skidding to be unlikely based his or her driving skill, occupant **251** can activate switch **244**. In turn, switch **244** can send a signal **238** to skid correction module **233**. Skid correction module **233** can receive the signal **238** from switch **244**. The signal **238** indicates to skid correction module **233** that vehicle **201** is skidding and occupant **251** has requested assistance recovering from the skidding.

Skid correction module **233** can request the type of skid from skid detection module **232**. Based on the request from skid correction module **233**, skid detection module **232** can infer a type of skid (as previously described). Skid detection module **232** can send a signal **236** indicating the type of skid back to skid correction module **233**.

Skid correction module **233** can include algorithms for addressing different types, severity, and durations of skidding (e.g., wheel lockup, over steer, under steer, counter skid (fishtailing), etc.). Addressing skidding for vehicle **201** can include formulating a configuration change to change the configuration of vehicle **201**. Based on a perceived environment in area **261** and a vehicle configuration for vehicle **201**, skid correction module **233** can formulate a configuration change to mitigate an indicated type of skid. Mitigating skidding reduces the possibility of damage to vehicle **201**.

Automated vehicle control systems **254** include systems for automatically controlling vehicle components **213**. Automated vehicle control systems **254** can use automated controls **253** to control vehicle components **213**. For example, a cruise control system can be used to control throttle **242**, a collision avoidance system can be used to control brakes **243**, etc. In one aspect, vehicle **201** includes systems for fully autonomous driving. Switch **244** can be activated to switch from manual driving mode to autonomous driving mode (which in addition to mitigating skids can perform a variety of other driving functions). In autonomous driving mode, automated vehicle control systems **254** essentially have complete control of vehicle components **213**.

Skid correction module **233** can send a configuration change **234** to mitigate skidding to automated vehicle control systems **254**. Automated vehicle control systems **254** can receive the configuration change **234** from skid correction module **233**. Automated vehicle control systems **254** can use automated controls **253** to change one or more of vehicle components **213** to implement the configuration change. A configuration change can include reducing throttle **242**, increasing throttle **242**, releasing brakes **243**, reducing brakes **243**, increasing brakes **243**, changing steering angle for one or more of wheels **241**, etc.

In some aspects, either of switch **244** or skid detection module **232** can request that skid correction module **233** provide automated assistance to mitigate skidding. Based on driving skill, occupant **251** may be able to mitigate various types and/or severity of skids by changing the configuration of vehicle components **213** with manual controls **252**. If at any time occupant **251** feels he or she lacks the driving skill to mitigate skidding, occupant **251** can activate switch **244** to request automated assistance to mitigate the skidding.

Skid detection module **232** can be configured to automatically intervene to mitigate skids when skid severity exceeds

a specified severity and/or skid duration last longer than a specified period of time (even if switch **244** is not activated). When skid detection module **232** detects skidding, skid detection module **232** can monitor the skidding to determine if skid severity exceeds the specified severity. If so, skid detection module **232** signals skid correction module **233** to provide automated assistance to mitigate the skidding.

If not, skid detection module **232** continues to monitor the skidding at designated intervals. At each designated interval, skid detection module **232** determines if skid severity is increasing or decreasing. If skid severity does not begin to decrease (e.g., occupant **251** begins to get the skidding under control) within the specified period of time, skid detection module **232** signals skid correction module **233** to provide automated assistance to mitigate the skidding. Alternately, if skid duration exceeds the specified period of time, skid detection module **232** signals skid correction module **233** to provide automated assistance to mitigate the skidding. Additionally, if at any time during monitoring, the skid severity increases to exceed the specified severity, skid detection module **232** signals skid correction module **233** to provide automated assistance to mitigate the skidding.

On the other hand, if skid severity begins to decrease within the specified period of time and does not exceed the specified severity, occupant **251** is permitted to mitigate the skidding using manual controls **252** (if he or she desires to do so).

FIG. 3 illustrates a flow chart of an example method **300** for controlling a skidding vehicle. Method **300** will be described with respect to the components and data of environment **200**.

Method **300** includes receiving a signal indicating that the vehicle is skidding and requesting automated corrective measures to reduce the possibility of vehicle damage due to the skidding (**301**). For example, skid correction module **233** can receive signal **238**. During operation of vehicle **201**, occupant **251** can determine that vehicle **201** is skidding and that he or she lacks the driving skill to mitigate the skidding. Occupant **251** can activate switch **244**. Activation of switch **244** sends signal **238** to skid correction module **233**. Signal **238** indicates to skid correction module **233** that vehicle **201** is skidding and that an occupant has requested automated corrective measures to reduce the possibility of damage to vehicle **201** due to the skidding.

Alternately or in combination, external sensors **202** can acquire sensor data **222** from area **261**. For example, LIDAR sensor(s) **203** can scan an area 360 degrees around vehicle **201** out to a distance of up to 200 meters. Environment perception module **208** can perceive perceived environment **224** within area **261**.

Additionally, internal sensors **207** can acquire sensor data **223** from vehicle components **213**. Configuration detection module **209** can detect configuration **226** from sensors data **223**.

From perceived environment **224** and configuration **226**, skid detection module **232** can determine that vehicle **201** is skidding. Further, skid detection module **232** can determine that the severity of the skid exceeds a specified severity and/or that vehicle **201** has been skidding for longer than a specified period to time. In response, skid detection module **232** can send signal **236** to skid correction module **233**. Signal **236** indicates to skid correction module **233** that vehicle **201** is skidding and that automated corrective measures are requested to reduce the possibility of damage to vehicle **201** due to the skidding. Signal **236** can also indicate a skid type to skid correction module **233**.

In one aspect, in response to receiving signal **238**, skid correction module **233** requests a skid type from skid detection module **232**. As such, skid correction module **233** can obtain a skid type (e.g., wheel lockup, understeer, oversteer, counter steer skid (fishtailing), etc.) when skid detection module **232** has not otherwise intervened.

Method **300** includes accessing a vehicle configuration of the vehicle and the environment around the vehicle (**302**). For example, skid correction module **233** can access perceived environment **224** from environment perception module **208**. Skid correction module **233** can also access configuration **226** from configuration detection module **209**.

Method **300** includes formulating an appropriate configuration change to address the skidding based at least on the vehicle configuration and the environment, the appropriate configuration change defining a change to one or more of: the steering angle of at least one wheel from among a plurality of wheels and the speed of at least one wheel from among the plurality of wheels (**303**). For example, based on configuration **226** and perceived environment **224**, skid correction module can formulate configuration change **234** to address the skidding of vehicle **201**. Configuration change **234** can define a change to one or more of: the steering angle of at least one of wheels **241** and the speed of at least one of wheels **241**.

Skid correction module **233** can send configuration change **234** to automated vehicle control systems **254**. Automated vehicle control systems **254** can receive configuration change **234** from skid correction module **233**.

Method **300** includes applying the configuration change at the vehicle to change the steering angle or speed of at least one wheel, from among the plurality of wheels, to mitigate the skidding (**304**). For example, automated vehicle control systems **254** can use automated controls **253** to apply configuration change **234** to vehicle components **213**. Applying configuration change **234** can change the steering angle or speed of at least one of wheels **241** to mitigate the skidding of vehicle **201**. Changing a steering angle of at least one of wheels **241** can include changing the configuration of a steering wheel. Changing the speed of at least one of wheels **241** can include one or more of: increasing throttle **242**, decreasing throttle **242**, releasing brakes **243**, reducing brakes **243**, or increasing brakes **243**.

Skid correction module **233** can formulate different configuration changes based on one or more of: skid type, skid severity, skid duration, vehicle type (e.g., front wheel drive, rear wheel drive, all-wheel drive, 4-wheel drive, car, truck, etc.) etc. Skid correction module **233** can formulate a plurality of different configuration changes (based on different skid recovery strategies) throughout a skid duration to attempt to bring vehicle **201** under control. Skid correction module **233** can dynamically change/update configuration changes throughout a skid duration based on changes in the perceived environment. In some aspects, during a skid, other systems of vehicle **201** can also have access to change vehicle components **213**. Thus, skid correction module **233** can also dynamically change/update configuration changes throughout a skid duration based on other changes to vehicle components **213**.

Oversteer occurs when a vehicle is going too fast for conditions and applies brakes while turning a corner. The braking shifts weight off of the rear tires and onto the front tires. The rear tires can skid due to the weight reduction. Oversteer can also happen going downhill around corners.

FIGS. **4A** and **4B** illustrate an example of an unmitigated oversteer skid and a corresponding mitigated oversteer skid. In FIG. **4A**, vehicle **401** attempts to turn right (as indicated

by front wheels **402** and **403**) but is going too fast. As such, the brakes are applied to slow before making the turn. However, application of the brakes shifts additional weight off of the rear wheels of vehicle **401** and onto wheels **402** and **403**. With less weight on the rear wheels, tires mounted to the rear wheels lose grip causing the rear of vehicle **401** to move as indicated by arrows **411**, **412**, and **413**.

A strategy for mitigating an oversteering skid can include releasing the brakes and possibly a small amount of acceleration to put weight back on the rear wheels to stop them from sliding. In FIG. **4B**, vehicle **401** includes components similar to those of vehicle **201**. For example, vehicle **401** can include a skid correction module configured to implement a strategy for mitigating an oversteer skid. Thus, if a driver of vehicle **401** lacks the driving skill to implement the strategy, the skid correction module can assist (or even intervene) to mitigate the oversteer skid.

In FIG. **4B**, similar to FIG. **4A**, vehicle **401** attempts to turn right (as indicated by front wheels **402** and **403**) but is going too fast. As such, the brakes are applied to slow before making the turn. Application of the brakes shifts additional weight off of the rear wheels of vehicle **401** and onto front wheels **402** and **403**. With less weight on the rear wheels, the rear tires lose grip causing the rear of vehicle **401** to move as indicated by arrow **414**. However, the skid correction module changes the configuration of vehicle **401** to return weight to the rear wheels and change the steering angle of wheels **402** and **403**. For example, the skid correction module can apply slight acceleration to return weight to the rear wheels. The change in configuration permits the driver to regain control of vehicle **401** as indicated by arrow **416**.

A counter steer skid (fishtail) can occur when a driver has met with oversteer and failed to appropriately correct. The rear end of the vehicle can skid back and forth, potentially building momentum with each swing. If not corrected on the first or second skid, subsequent skids can be more violent and difficult to recover from. Counter steer skids can occur when drivers correct late, overcorrect, and repeat the mistake.

FIGS. **5A** and **5B** illustrate an example of an unmitigated counter steer skid (fishtail) and a corresponding mitigated counter steer skid. In FIG. **5A**, vehicle **501** attempts to turn right (as indicated by front wheels **502** and **503**) but is going too fast. As such, the brakes are applied to slow before making the turn. However, application of the brakes shifts additional weight off of the rear wheels of vehicle **501** and onto front wheels **502** and **503**. With less weight on the rear wheels, the rear tires lose grip causing the rear of vehicle **501** to move as indicated by arrows **511**. The driver of vehicle **501** fails to compensate appropriately causing the rear of vehicle **501** to move in the other direction as indicated by arrow **512**. The driver of vehicle **501** again fails to compensate appropriately causing the rear of vehicle **501** to move in the other direction as indicated by arrow **513**.

A strategy for mitigating counter steer is to limit corrective steering to point the front tires in the direction the car is to go. The wheel is straightening as the vehicle straightens so that the wheels are also pointed down the road. In FIG. **5B**, vehicle **501** includes components similar to those of vehicle **201**. For example, vehicle **501** can include a skid correction module configured to implement the strategy for mitigating counter steer skids. Thus, if a driver of vehicle **501** lacks the driving skill to implement the strategy, the skid correction module can assist (or even intervene) to mitigate counter steer skidding.

In FIG. **5B**, similar to FIG. **5A**, vehicle **501** attempts to turn right (as indicated by front wheels **502** and **503**) but is

going too fast. As such, the brakes are applied to slow before making the turn. Application of the brakes shifts additional weight off of the rear wheels of vehicle **501** and onto front wheels **502** and **503**. With less weight on the rear wheels, the rear tires lose grip causing the rear of vehicle **501** to move as indicated by arrow **514**. However, the skid correction module changes the configuration of vehicle **501** to return weight to the rear wheels. The skid correction module also maintains the steering angle of wheels **502** and **503** to remain pointed down the roadway as indicated by arrows **521** and **522**. The change in configuration permits the driver to regain control of vehicle **501**.

In one aspect, a skid detection module at vehicle **501** monitors skid type, skid severity, and skid duration for vehicle **501**. The skid detection module may initially permit the driver of vehicle **501** to attempt corrective action to mitigate the counter steer skidding. For example, skid detection module can monitor the skids indicated by arrows **511** and **512**. However, after monitoring the skid indicated by arrow **512**, the skid detection module signals the skid correction module to intervene (even if the driver has not requested assistance with the counter steer skids via a manual switch).

Understeer occurs when front tires lose grip and a vehicle is unable to turn a corner. Understeer can occur when a vehicle approaches a turn going too fast. Spinning the front tires or locking the front tires in a corner can also cause understeer.

FIGS. **6A** and **6B** illustrate an example of an unmitigated understeer skid and a corresponding mitigated understeer skid. In FIG. **6A**, vehicle **601** attempts to turn right (as indicated by front wheels **602** and **603**) but is going too fast based on roadway conditions. As such, front wheels **602** and **603** lose grip with the roadway, causing vehicle **601** to miss the turn.

A strategy for mitigating understeer is to let off the accelerator and gently apply the brakes. Applying the brakes shifts some weight off the rear wheels onto the front wheels. The additional weight on the front tires can help the front tires better grip the roadway. In FIG. **6B**, vehicle **601** includes components similar to those of vehicle **201**. Vehicle **601** can include a skid correction module configured to implement the strategy for mitigating understeer skids. Thus, if a driver of vehicle **601** lacks the driving skill to implement the strategy, the skid correction module can assist (or even intervene) to mitigate understeer skidding.

In FIG. **6B**, similar to FIG. **6A**, vehicle **601** attempts to turn right (as indicated by front wheels **602** and **603**) but is going too fast. Vehicle **601** starts an understeer skid. However, the skid correction module changes the configuration of vehicle **501** to shift weight to front wheels **602** and **603**. For example, the skid correction module can apply the brakes to shift additional weight onto front wheels **602** and **603**. With additional weight on front wheels **602** and **603**, the front tires (mounted to front wheels **602** and **603**) are better able to grip the roadway. As such, the change in configuration permits the driver to regain control of vehicle **601**. Vehicle **601** remains on the roadway and makes the turn.

In one aspect, one or more processors are configured to execute instructions (e.g., computer-readable instructions, computer-executable instructions, etc.) to perform any of a plurality of described operations. The one or more processors can access information from system memory and/or store information in system memory. The one or more processors can transform information between different formats, such as, for example, sensor data, perceived environ-

ments, vehicle configurations, switch activations, signals, configuration changes, skid types, skid severity, skid duration, etc.

System memory can be coupled to the one or more processors and can store instructions (e.g., computer-readable instructions, computer-executable instructions, etc.) executed by the one or more processors. The system memory can also be configured to store any of a plurality of other types of data generated by the described components, such as, for example, sensor data, perceived environments, vehicle configurations, switch activations, signals, configuration changes, skid types, skid severity, skid duration, etc.

In the above disclosure, reference has been made to the accompanying drawings, which form a part hereof, and in which is shown by way of illustration specific implementations in which the disclosure may be practiced. It is understood that other implementations may be utilized and structural changes may be made without departing from the scope of the present disclosure. References in the specification to “one embodiment,” “an embodiment,” “an example embodiment,” etc., indicate that the embodiment described may include a particular feature, structure, or characteristic, but every embodiment may not necessarily include the particular feature, structure, or characteristic. Moreover, such phrases are not necessarily referring to the same embodiment. Further, when a particular feature, structure, or characteristic is described in connection with an embodiment, it is submitted that it is within the knowledge of one skilled in the art to affect such feature, structure, or characteristic in connection with other embodiments whether or not explicitly described.

Implementations of the systems, devices, and methods disclosed herein may comprise or utilize a special purpose or general-purpose computer including computer hardware, such as, for example, one or more processors and system memory, as discussed herein. Implementations within the scope of the present disclosure may also include physical and other computer-readable media for carrying or storing computer-executable instructions and/or data structures. Such computer-readable media can be any available media that can be accessed by a general purpose or special purpose computer system. Computer-readable media that store computer-executable instructions are computer storage media (devices). Computer-readable media that carry computer-executable instructions are transmission media. Thus, by way of example, and not limitation, implementations of the disclosure can comprise at least two distinctly different kinds of computer-readable media: computer storage media (devices) and transmission media.

Computer storage media (devices) includes RAM, ROM, EEPROM, CD-ROM, solid state drives (“SSDs”) (e.g., based on RAM), Flash memory, phase-change memory (“PCM”), other types of memory, other optical disk storage, magnetic disk storage or other magnetic storage devices, or any other medium which can be used to store desired program code means in the form of computer-executable instructions or data structures and which can be accessed by a general purpose or special purpose computer.

An implementation of the devices, systems, and methods disclosed herein may communicate over a computer network. A “network” is defined as one or more data links that enable the transport of electronic data between computer systems and/or modules and/or other electronic devices. When information is transferred or provided over a network or another communications connection (either hardwired, wireless, or a combination of hardwired or wireless) to a computer, the computer properly views the connection as a

transmission medium. Transmissions media can include a network and/or data links, which can be used to carry desired program code means in the form of computer-executable instructions or data structures and which can be accessed by a general purpose or special purpose computer. Combinations of the above should also be included within the scope of computer-readable media.

Computer-executable instructions comprise, for example, instructions and data which, when executed at a processor, cause a general purpose computer, special purpose computer, or special purpose processing device to perform a certain function or group of functions. The computer executable instructions may be, for example, binaries, intermediate format instructions such as assembly language, or even source code. Although the subject matter has been described in language specific to structural features and/or methodological acts, it is to be understood that the subject matter defined in the appended claims is not necessarily limited to the described features or acts described above. Rather, the described features and acts are disclosed as example forms of implementing the claims.

Those skilled in the art will appreciate that the disclosure may be practiced in network computing environments with many types of computer system configurations, including, an in-dash or other vehicle computer, personal computers, desktop computers, laptop computers, message processors, hand-held devices, multi-processor systems, microprocessor-based or programmable consumer electronics, network PCs, minicomputers, mainframe computers, mobile telephones, PDAs, tablets, pagers, routers, switches, various storage devices, and the like. The disclosure may also be practiced in distributed system environments where local and remote computer systems, which are linked (either by hardwired data links, wireless data links, or by a combination of hardwired and wireless data links) through a network, both perform tasks. In a distributed system environment, program modules may be located in both local and remote memory storage devices.

Further, where appropriate, functions described herein can be performed in one or more of: hardware, software, firmware, digital components, or analog components. For example, one or more application specific integrated circuits (ASICs) can be programmed to carry out one or more of the systems and procedures described herein. Certain terms are used throughout the description and claims to refer to particular system components. As one skilled in the art will appreciate, components may be referred to by different names. This document does not intend to distinguish between components that differ in name, but not function.

It should be noted that the sensor embodiments discussed above may comprise computer hardware, software, firmware, or any combination thereof to perform at least a portion of their functions. For example, a sensor may include computer code configured to be executed in one or more processors, and may include hardware logic/electrical circuitry controlled by the computer code. These example devices are provided herein purposes of illustration, and are not intended to be limiting. Embodiments of the present disclosure may be implemented in further types of devices, as would be known to persons skilled in the relevant art(s).

At least some embodiments of the disclosure have been directed to computer program products comprising such logic (e.g., in the form of software) stored on any computer useable medium. Such software, when executed in one or more data processing devices, causes a device to operate as described herein.

While various embodiments of the present disclosure have been described above, it should be understood that they have been presented by way of example only, and not limitation. It will be apparent to persons skilled in the relevant art that various changes in form and detail can be made therein without departing from the spirit and scope of the disclosure. Thus, the breadth and scope of the present disclosure should not be limited by any of the above-described exemplary embodiments, but should be defined only in accordance with the following claims and their equivalents. The foregoing description has been presented for the purposes of illustration and description. It is not intended to be exhaustive or to limit the disclosure to the precise form disclosed. Many modifications and variations are possible in light of the above teaching. Further, it should be noted that any or all of the aforementioned alternate implementations may be used in any combination desired to form additional hybrid implementations of the disclosure.

What is claimed:

1. A method for controlling a vehicle that is skidding, the method comprising:

receiving a request for automated corrective measures to control the skidding from an operator of the vehicle through an operator actuated switch dedicated to invoking the automated corrective measures to control the skidding;

formulating a configuration change for changing the configuration of at least one vehicle component in response to the request; and

applying the configuration change at the vehicle to change the configuration of the at least one vehicle component to mitigate the skidding.

2. The method of claim 1, wherein formulating a configuration change for changing the configuration of at least one vehicle component comprises formulating a configuration change to address one of: an oversteer skid, an understeer skid, or a counter steer skid.

3. The method of claim 1, wherein formulating a configuration change for changing the configuration of at least one vehicle component comprises formulating a configuration change based on a perceived environment surrounding the vehicle, the perceived environment inferred from sensor data acquired from one or more LIDAR sensors.

4. The method of claim 1, wherein applying the configuration change at the vehicle to change the configuration of the at least one vehicle component comprises applying the configuration change to change one or more of: the steering angle of a wheel of the vehicle, braking at the vehicle, and acceleration at the vehicle.

5. A vehicle, the vehicle comprising:
one or more sensors for sensing operation of the vehicle and sensing the environment surrounding the vehicle out to a specified range;

a plurality of wheels;

one or more processors;

a manually actuated switch dedicated to invoking automated corrective measures to control the skidding, the manually actuated switch being mounted to a steering wheel of the vehicle;

system memory coupled to one or more processors, the system memory storing instructions that are executable by the one or more processors;

the one or more processors configured to execute the instructions stored in the system memory to control the vehicle in a skid, including the following:

receive a signal from the manually actuated switch indicating that a user has actuated the switch;

13

access a vehicle configuration of the vehicle and the environment around the vehicle;

formulate an appropriate configuration change to address the skidding based at least on the vehicle configuration and the environment, the appropriate configuration change defining a change to one or more of: the steering angle of at least one wheel from among the plurality of wheels and the speed of at least one wheel from among the plurality of wheels; and

apply the configuration change at the vehicle to change the steering angle or speed of at least one wheel, from among the plurality of wheels, to mitigate the skidding.

6. The vehicle of claim 5, further comprising the one or more processors configured to execute the instructions stored in the system memory to:

detect the vehicle configuration from sensor data, the sensor data acquired from sensors monitoring components of the vehicle; and

perceive the environment around the vehicle from other sensor data, the other sensor data acquired from sensors monitoring an area around the vehicle.

7. The vehicle of claim 6, wherein the one or more processors configured to execute the instructions stored in the system memory to perceive the environment around the vehicle from other sensor data comprise the one or more processors configured to execute the instructions stored in the system memory to perceive the environment around the vehicle from other sensor data acquired from one or more LIDAR sensors.

8. The vehicle of claim 5, wherein the one or more processors configured to execute the instructions stored in the system memory to formulate an appropriate configuration change to address the skidding comprise the one or more processors configured to execute the instructions stored in the system memory to formulate an appropriate configuration change address one of: an oversteer skid, an understeer skid, or a counter steer skid.

9. The vehicle of claim 5, wherein the one or more processors configured to execute the instructions stored in the system memory to access a vehicle configuration of the vehicle comprise the one or more processors configured to execute the instructions stored in the system memory to access an indication that the duration of the skidding has exceed a specified period of time.

10. The vehicle of claim 5, wherein the one or more processors configured to execute the instructions stored in the system memory to access a vehicle configuration of the

14

vehicle comprise the one or more processors configured to execute the instructions stored in the system memory to access an indication that the severity of the skidding has exceed a threshold severity.

11. The vehicle of claim 10, wherein the one or more processors configured to execute the instructions stored in the system memory to apply the configuration change at the vehicle comprise the one or more processors configured to execute the instructions stored in the system memory to override manual operation of the vehicle to apply the configuration change at the vehicle.

12. The vehicle of claim 10, wherein the one or more processors configured to execute the instructions stored in the system memory to apply the configuration change at the vehicle comprise the one or more processors configured to execute the instructions stored in the system memory to change one of: acceleration at the vehicle or braking at the vehicle.

13. A method for automatically controlling a skidding vehicle, the vehicle including a plurality of wheels, the method comprising:

receiving a signal from a manually actuated switch dedicated to invoking automated corrective measures to control the skidding, the signal indicating that the vehicle is skidding and requesting automated corrective measures to reduce the skidding;

accessing a vehicle configuration of the vehicle and the environment around the vehicle by evaluating input from the one or more sensors;

formulating an appropriate configuration change to address the skidding based at least on the vehicle configuration and the environment, the appropriate configuration change defining a change to one or more of: the steering angle of at least one wheel from among the plurality of wheels and the speed of at least one wheel from among the plurality of wheels; and

applying the configuration change at the vehicle to change the steering angle or speed of at least one wheel, from among the plurality of wheels, to mitigate the skidding.

14. The method of claim 13, wherein formulating an appropriate configuration change to address the skidding comprises formulating an appropriate configuration change to address one of: oversteer skidding, understeer skidding, or counter steer skidding.

15. The method of claim 13, wherein applying the configuration change at the vehicle comprises changing one of: acceleration at the vehicle or braking at the vehicle.

* * * * *