



US010020585B2

(12) **United States Patent**
Muesse et al.

(10) **Patent No.:** **US 10,020,585 B2**
(45) **Date of Patent:** ***Jul. 10, 2018**

- (54) **SOLDIER-MOUNTED ANTENNA**
- (71) Applicant: **Trivec-Avant Corporation**, Huntington Beach, CA (US)
- (72) Inventors: **Allen R. Muesse**, San Clemente, CA (US); **Steven R. Mills**, Mission Viejo, CA (US); **John E. Fenick**, Aliso Viejo, CA (US); **Fernando J. Navarro**, Chino, CA (US); **David F. Macy**, Mission Viejo, CA (US)
- (73) Assignee: **Trivec-Avant Corporation**, Huntington Beach, CA (US)

(*) Notice: Subject to any disclaimer, the term of this patent is extended or adjusted under 35 U.S.C. 154(b) by 0 days.

This patent is subject to a terminal disclaimer.

(21) Appl. No.: **15/640,219**

(22) Filed: **Jun. 30, 2017**

(65) **Prior Publication Data**
US 2017/0310013 A1 Oct. 26, 2017

Related U.S. Application Data
(63) Continuation of application No. 13/762,836, filed on Feb. 8, 2013, now Pat. No. 9,711,859.
(60) Provisional application No. 61/597,621, filed on Feb. 10, 2012.

(51) **Int. Cl.**
H01Q 11/08 (2006.01)
H01Q 1/12 (2006.01)
H01Q 1/27 (2006.01)

(52) **U.S. Cl.**
CPC **H01Q 11/086** (2013.01); **H01Q 1/1235** (2013.01); **H01Q 1/273** (2013.01)

(58) **Field of Classification Search**
CPC ... H01Q 11/086; H01Q 1/1235; H01Q 1/273; H01Q 1/288; H01Q 1/362
See application file for complete search history.

(56) **References Cited**
U.S. PATENT DOCUMENTS
3,055,003 A 9/1962 Marston et al.
3,913,109 A 10/1975 Owen
4,053,896 A 10/1977 Bitter, Jr. et al.
4,780,727 A 10/1988 Seal et al.
(Continued)

OTHER PUBLICATIONS
Memry Corporation, Fabrication and Heat Treatment of Nitinol, <http://www.memry.com/nitinol-iq/nitinol-fundamentals/fabrication-heat-tr...>, (accessed Jan. 30, 2013) 1 page, 2012.
(Continued)

Primary Examiner — Robert Karacsony
(74) *Attorney, Agent, or Firm* — Knobbe Martens Olson & Bear LLP

(57) **ABSTRACT**
Embodiments of a wide band multi-polarization antenna system are described, which can be attached to the back or front of a soldier's vest or backpack. The antenna system can allow for release of pre-shaped integral radiating elements that spring into a geometric configuration suitable for circular polarization radiation or linear polarization over a desired band of frequencies. The antenna system can provide, when collapsed, linear polarized line-of sight capability over a wide band of frequencies. In a collapsed low-profile state, the antenna system can remain on the soldier, but out of the way for maneuvering.

30 Claims, 32 Drawing Sheets

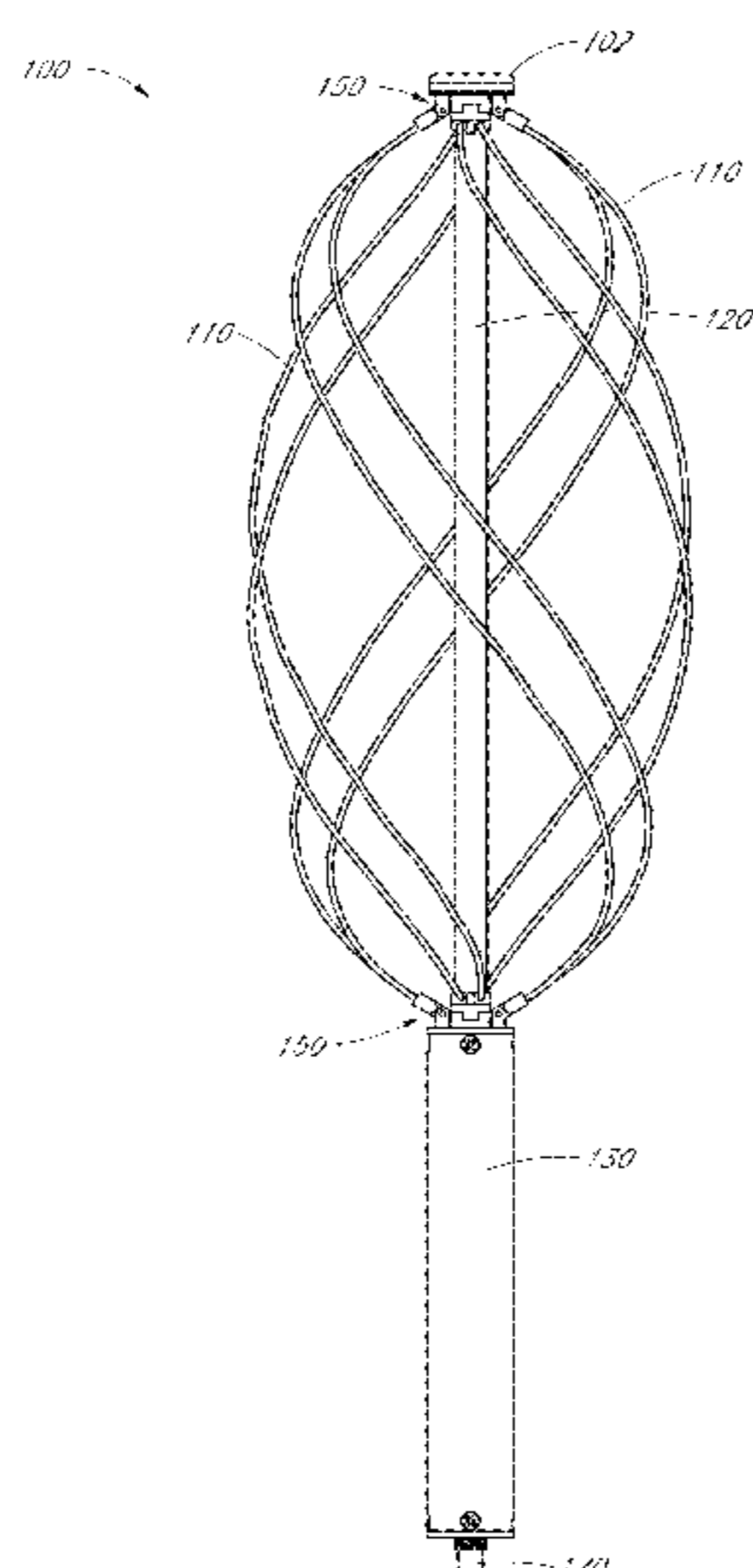

(56)

References Cited

U.S. PATENT DOCUMENTS

5,191,352 A * 3/1993 Branson H01Q 1/362
343/850

5,668,565 A 9/1997 Robinson
5,963,180 A 10/1999 Leisten
5,977,932 A 11/1999 Robinson
6,094,178 A * 7/2000 Sanford H01Q 1/242
343/860

6,150,984 A 11/2000 Suguro et al.
6,339,408 B1 * 1/2002 Edvardsson H01Q 1/242
343/702

6,906,683 B2 6/2005 Ikeda et al.
7,236,681 B2 6/2007 Moheb et al.
7,667,651 B2 2/2010 McKivergan
8,339,326 B2 12/2012 Guler et al.
9,711,859 B1 * 7/2017 Muesse H01Q 1/273

2005/0237256 A1 10/2005 Regala
2008/0094307 A1 4/2008 Cowles
2010/0102931 A1 4/2010 Nikitin et al.
2010/0260076 A1 10/2010 Corman et al.

2012/0026937 A1 2/2012 Chang
2012/0280869 A1 * 11/2012 Kirkham H01Q 1/084
343/718

2015/0333391 A1 * 11/2015 Pryor H01Q 1/08
343/718

OTHER PUBLICATIONS

Instruction Manual for P/N AV 2125-() UHF Satcom Antenna System, Document No. 2125-103 (retrieved Feb. 2, 2012) 2 pages.
Antenna Book, 21st Edition, Chapter 2, (retrieved Jan. 17, 2012) 6 pages.
The Quadrifilar Helix Antenna, Chapter 22, www.electroda.pl/rtvforum/download.php?id=291305, last accessed on Feb. 15, 2013, pp. 22-1-22-20.
Johnson Matthey Engineering Reference, Nitinol Products, 65 pages, 2004.
The ARRL Antenna Book, 21st Edition, Chapter 19, May 1, 2007, pp. 19-2-19-4.

* cited by examiner

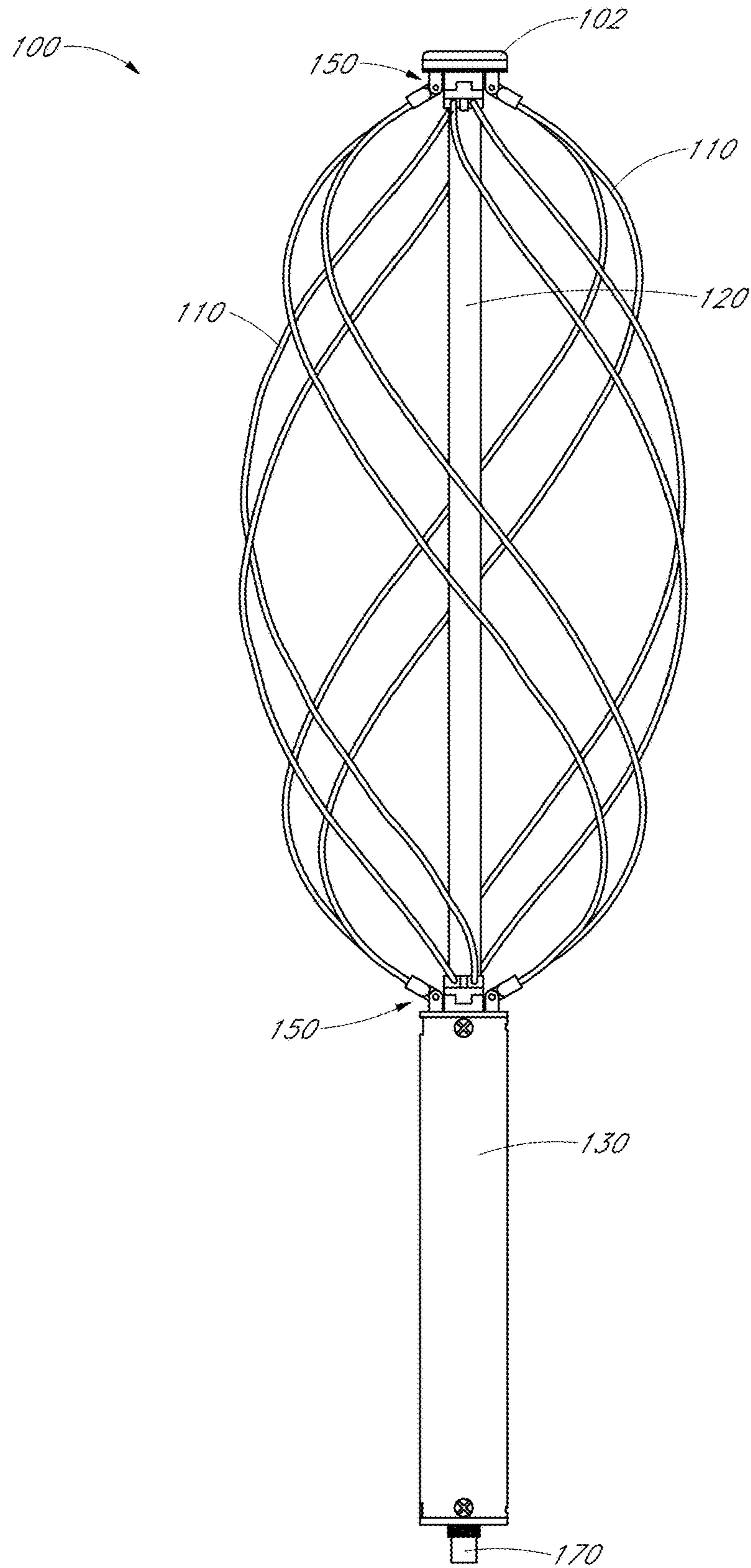

FIG. 1

100

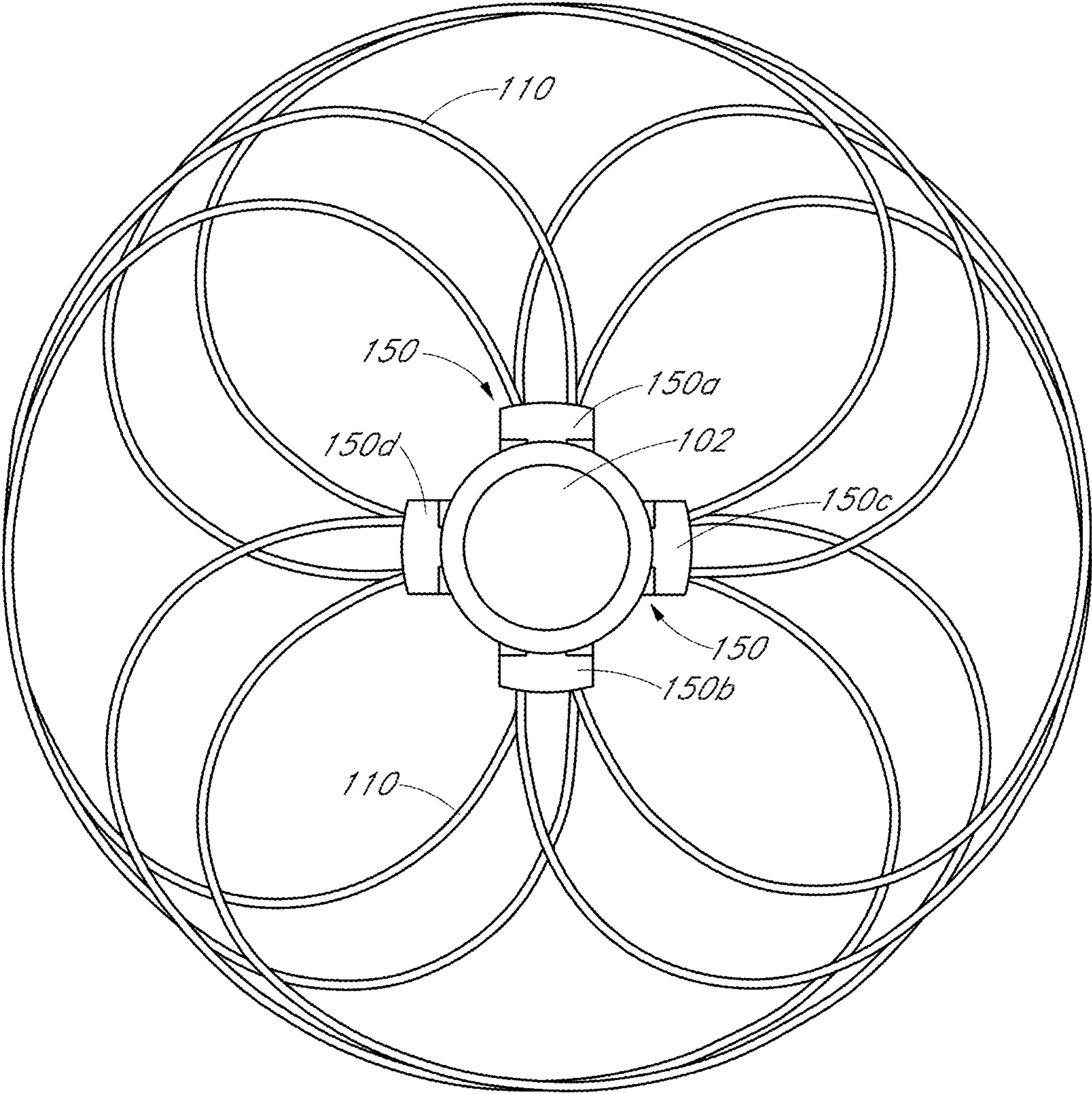

FIG. 2

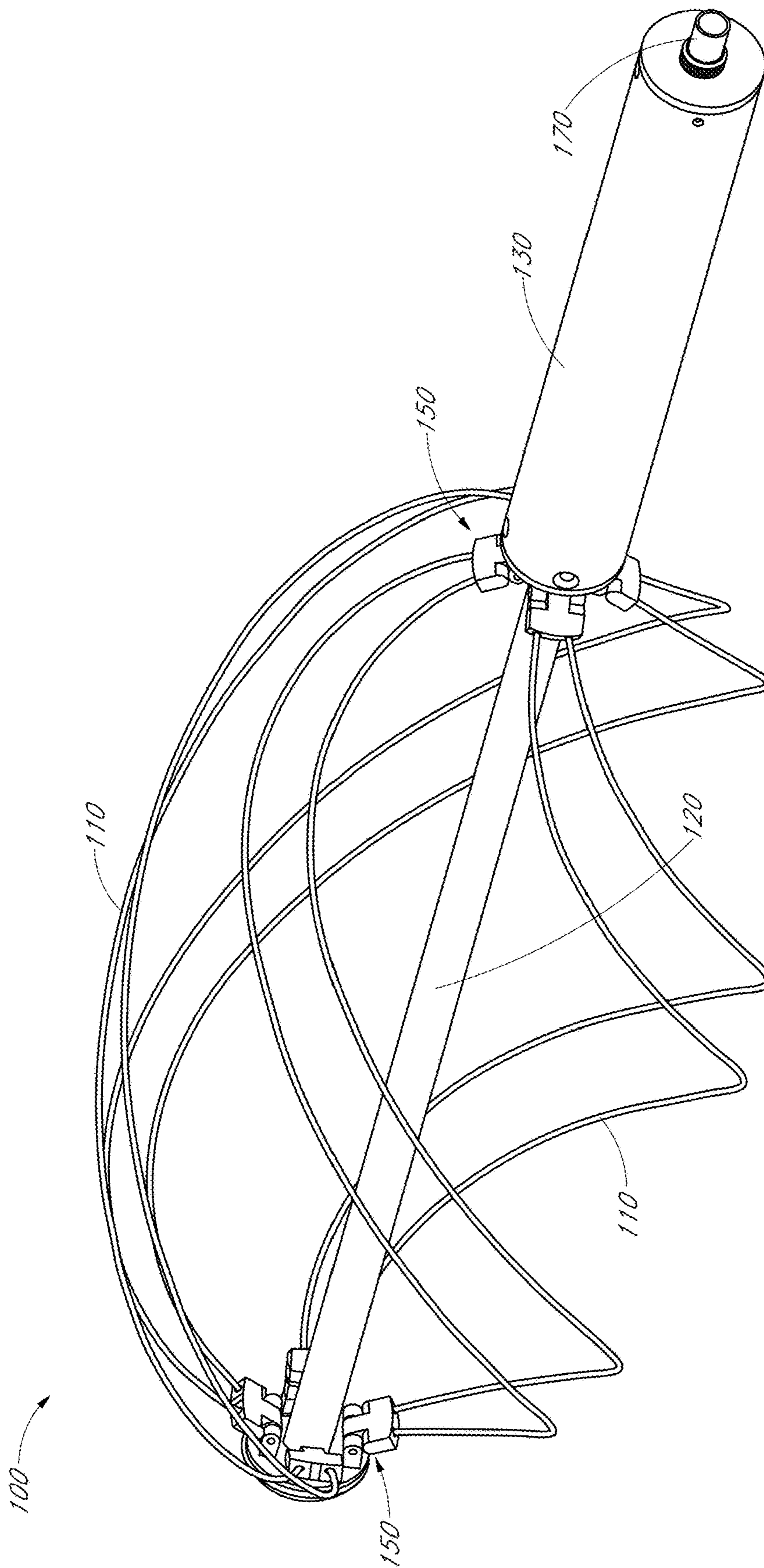

FIG. 3

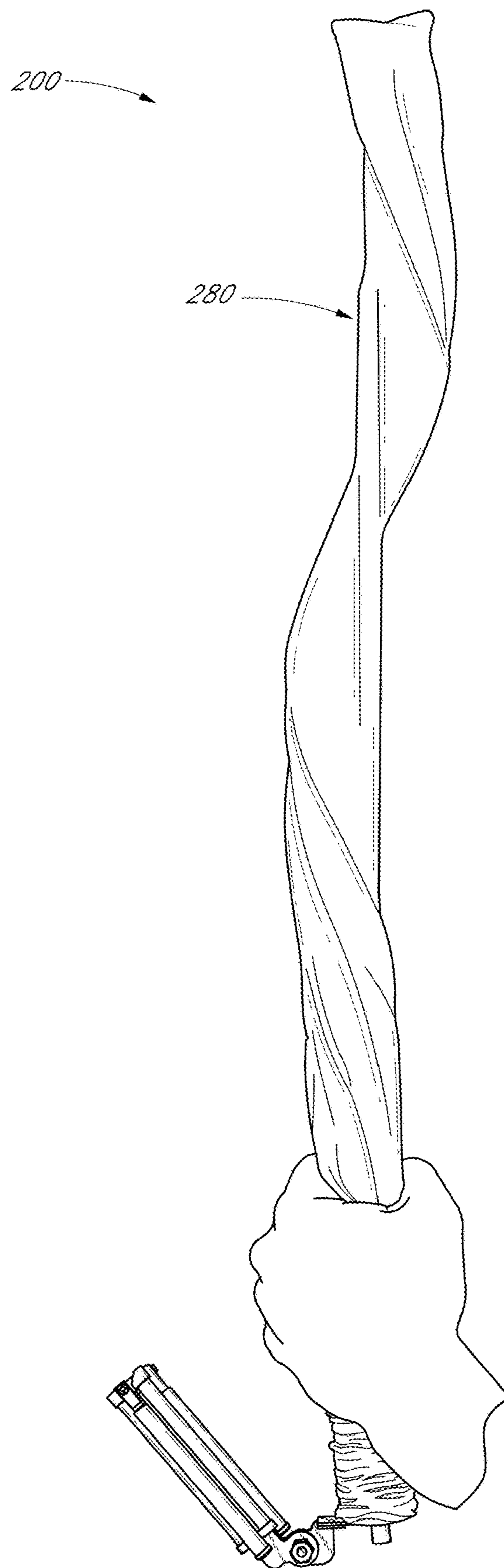

FIG. 4

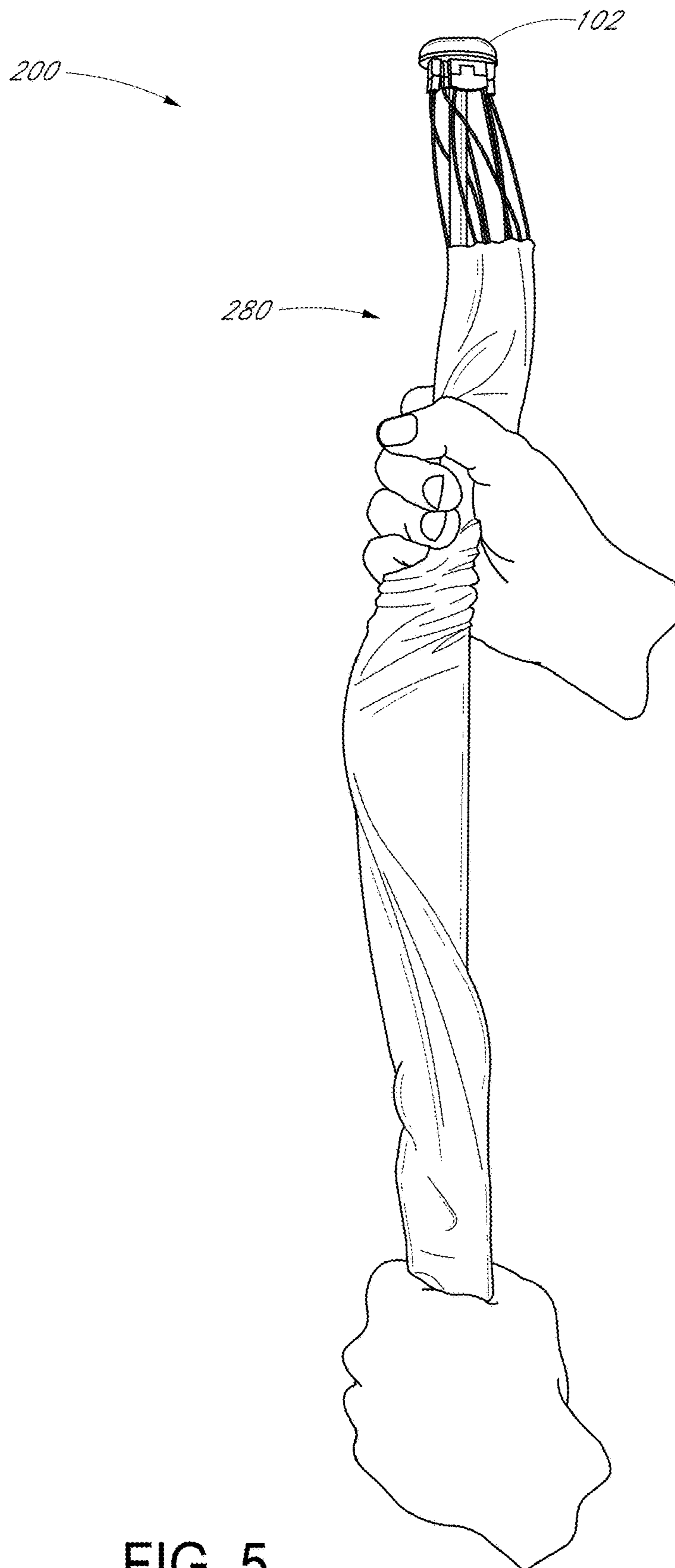

FIG. 5

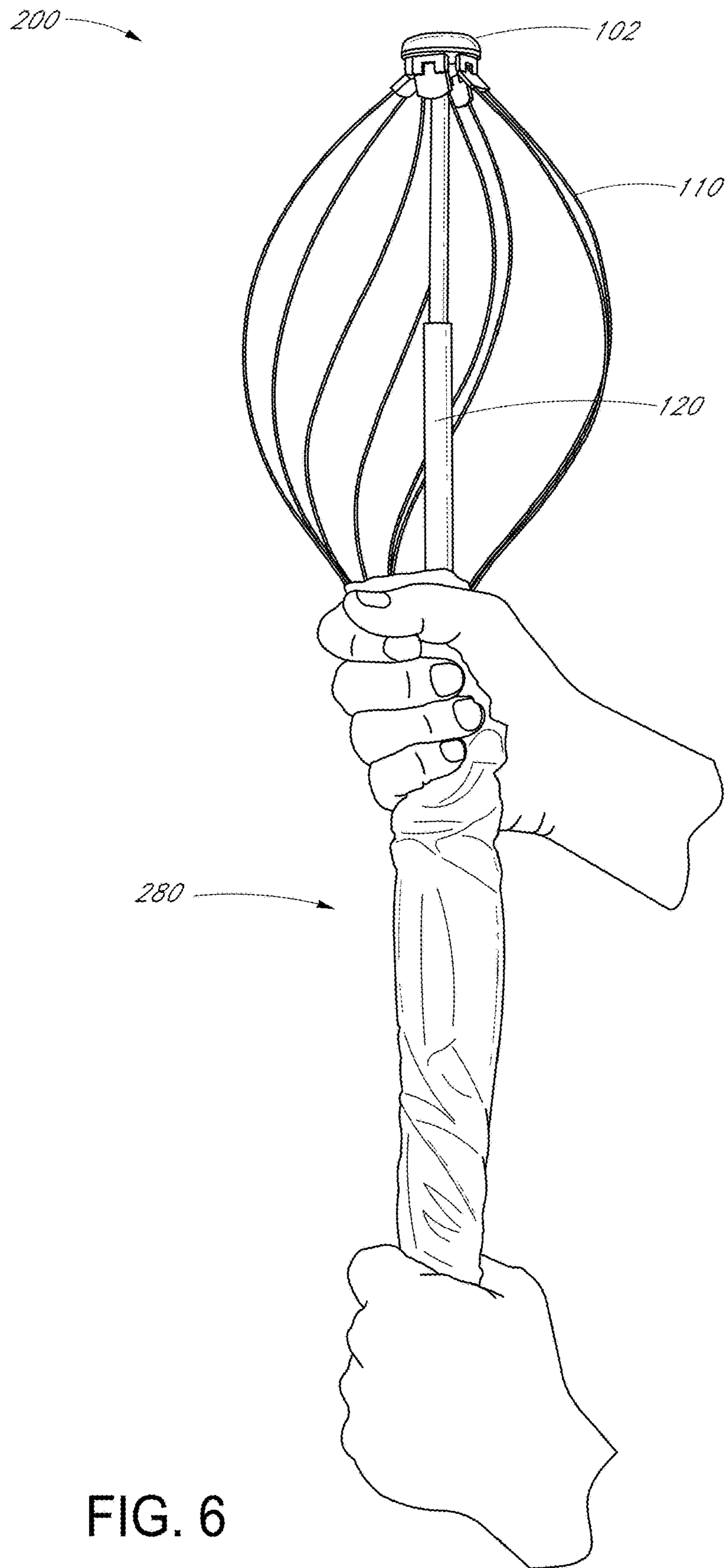

FIG. 6

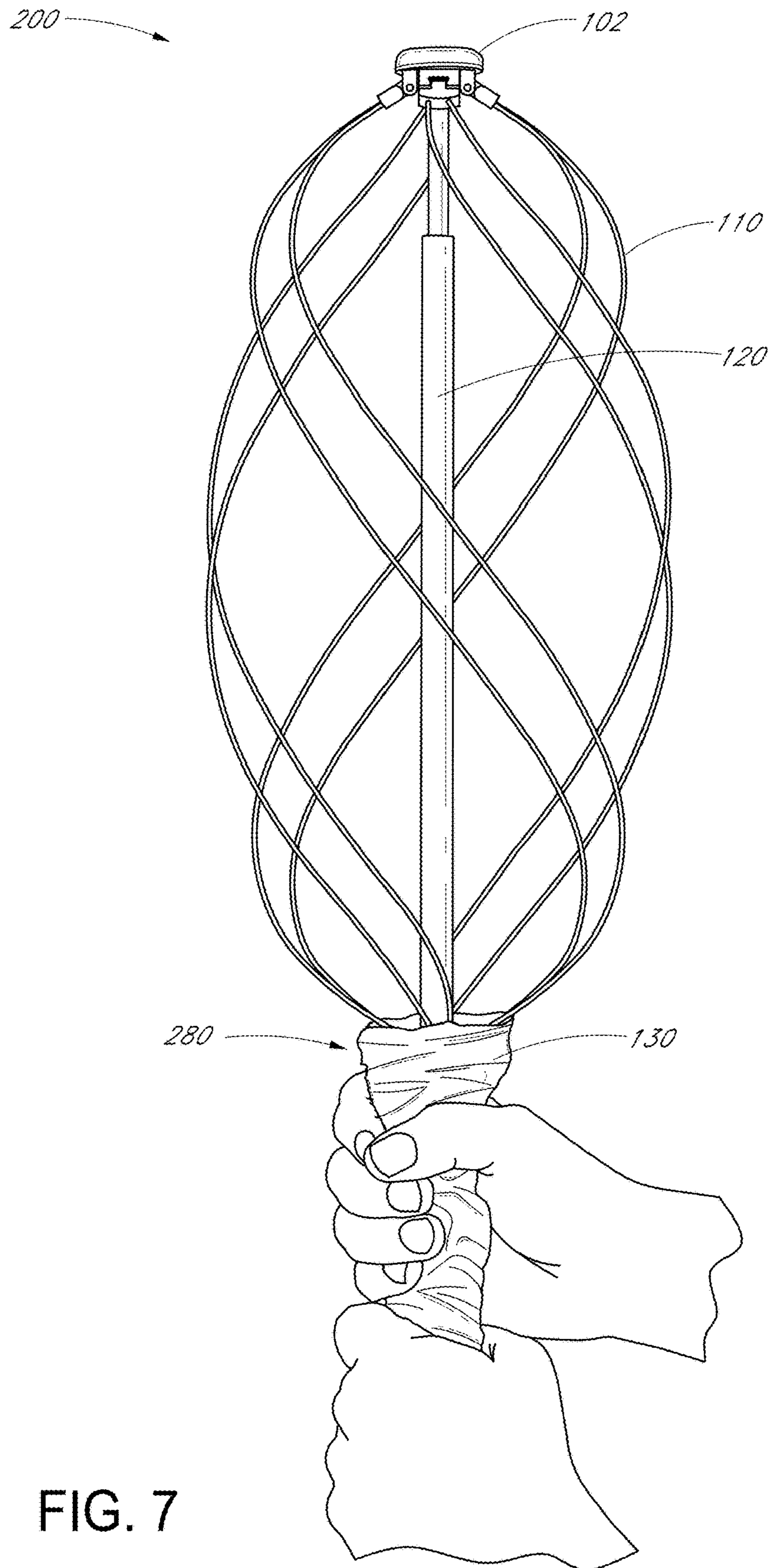

FIG. 7

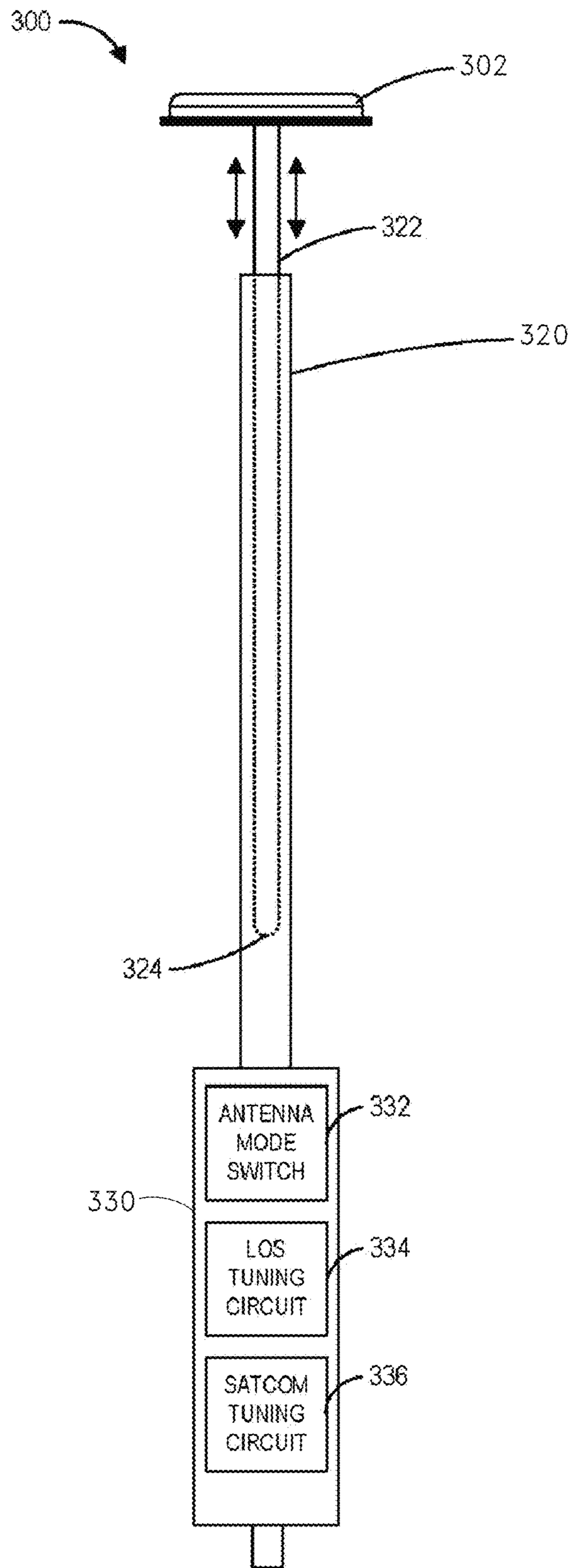

FIG. 8

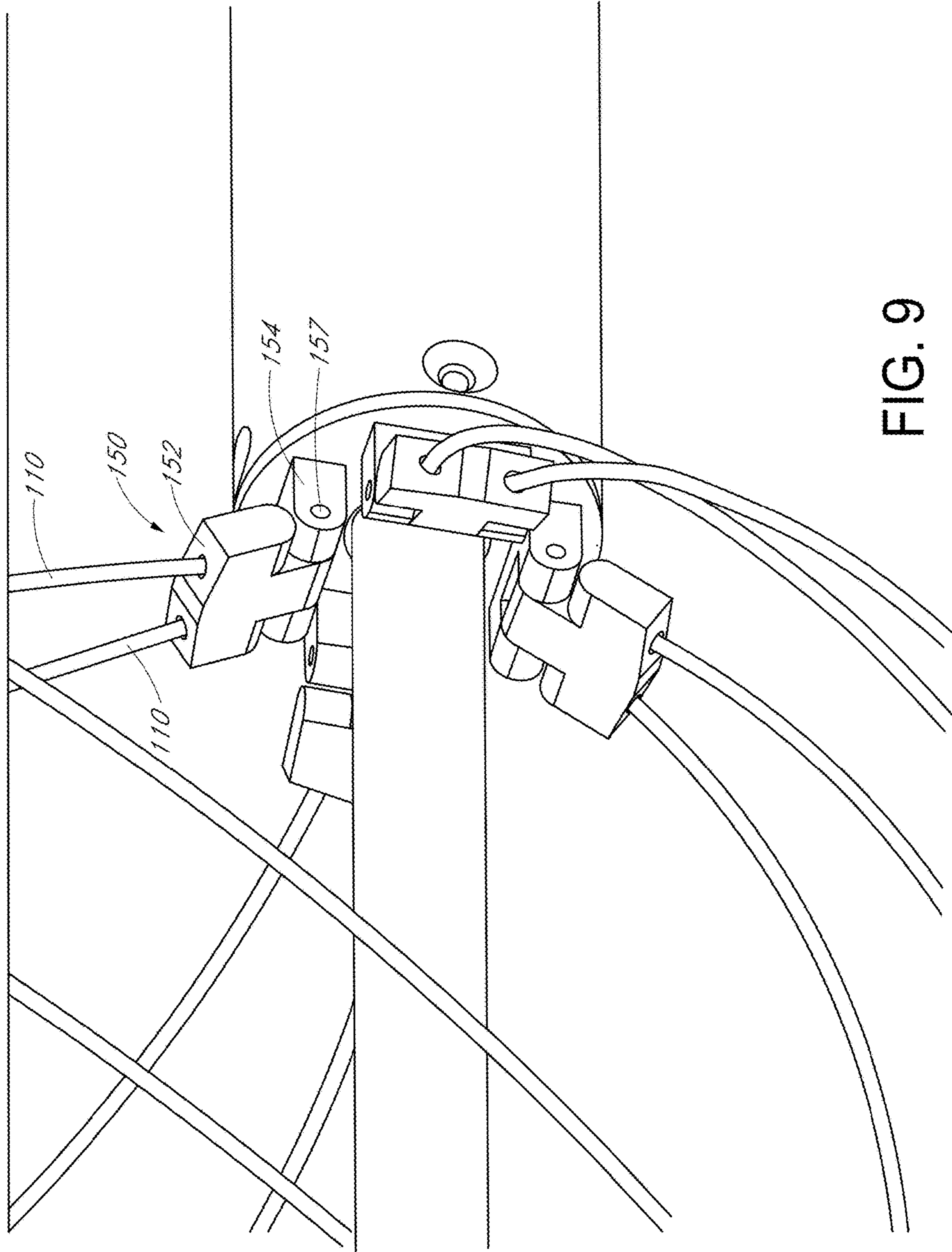

FIG. 9



FIG. 10

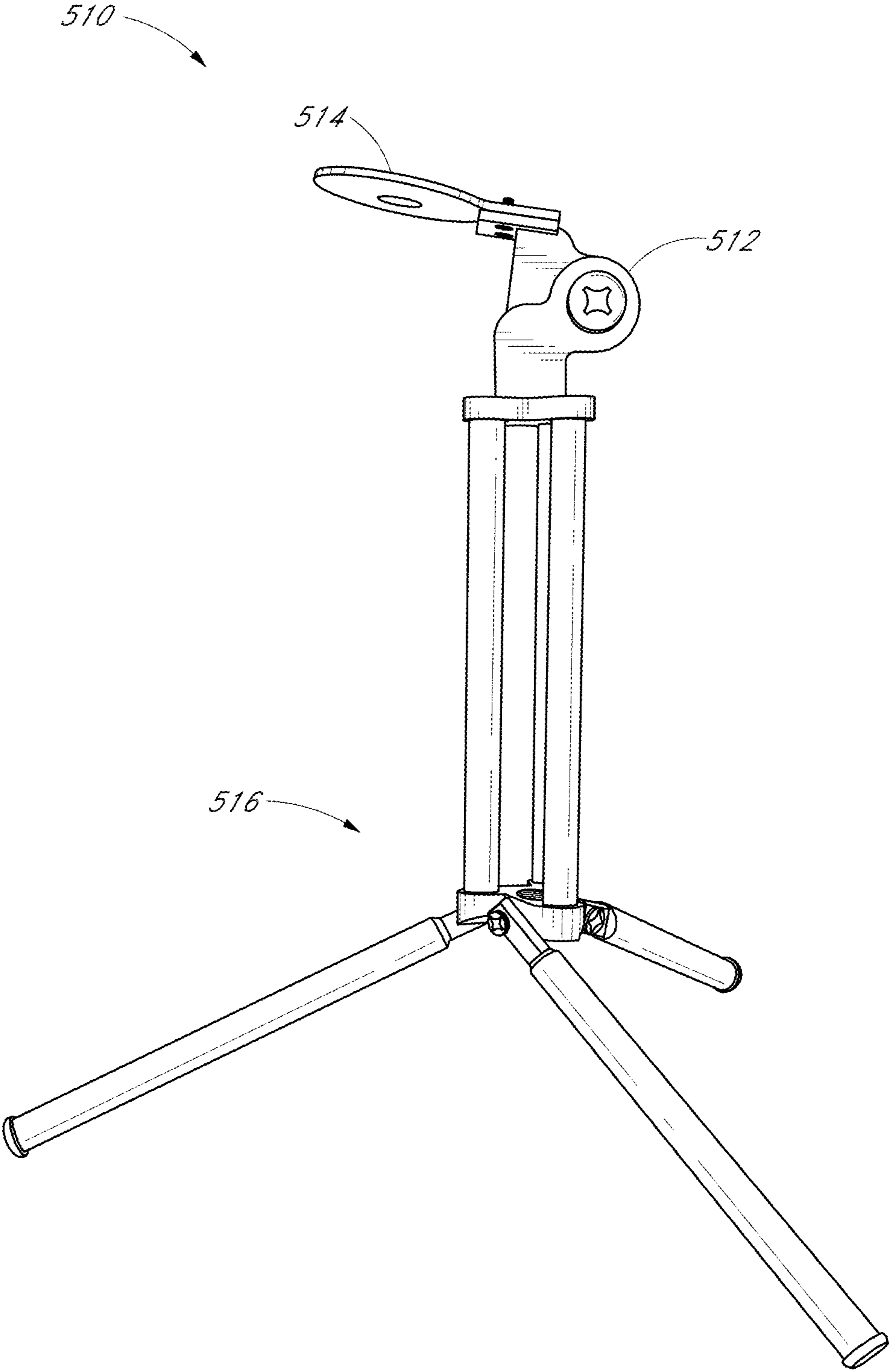

FIG. 11

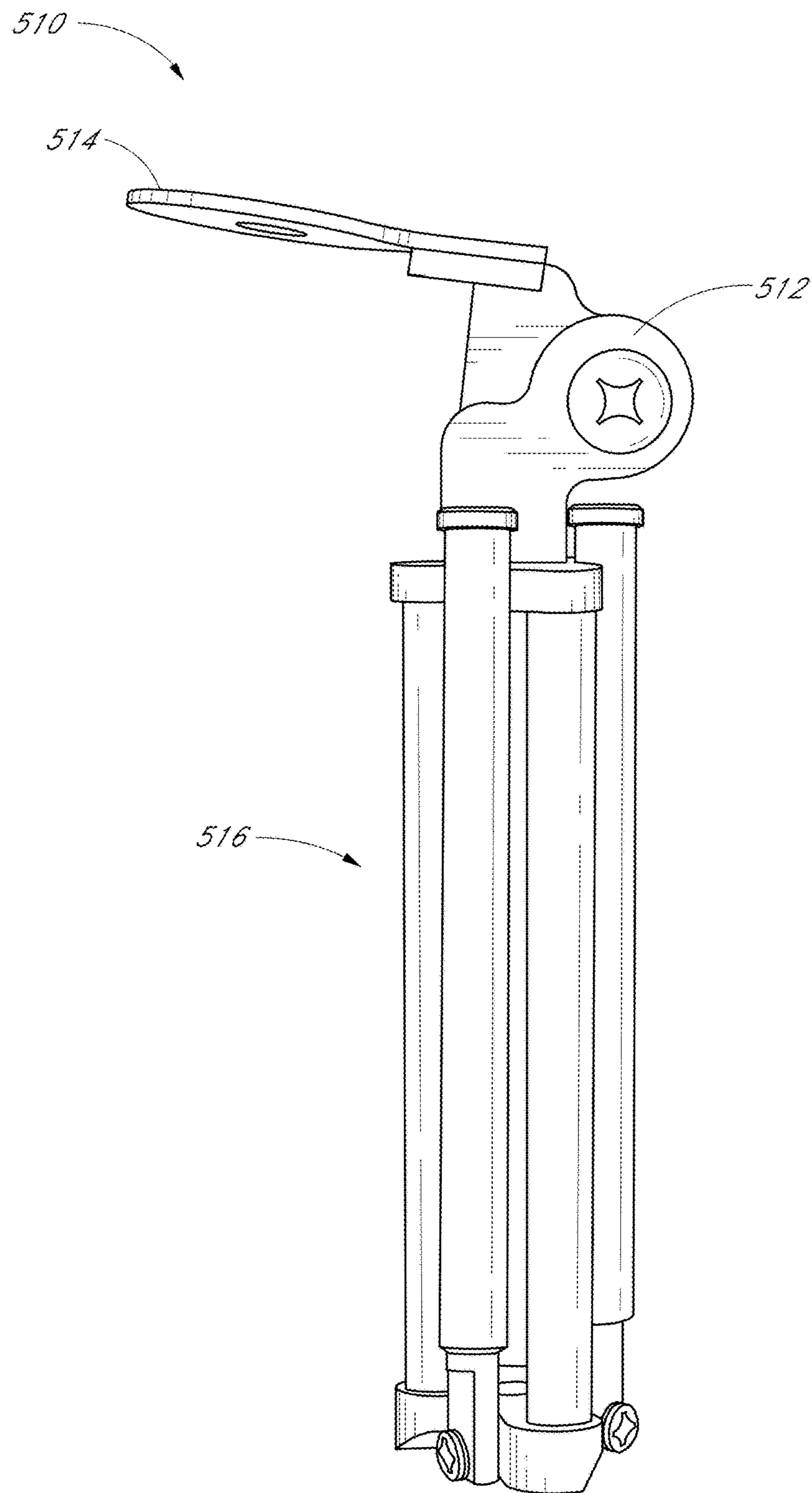

FIG. 12

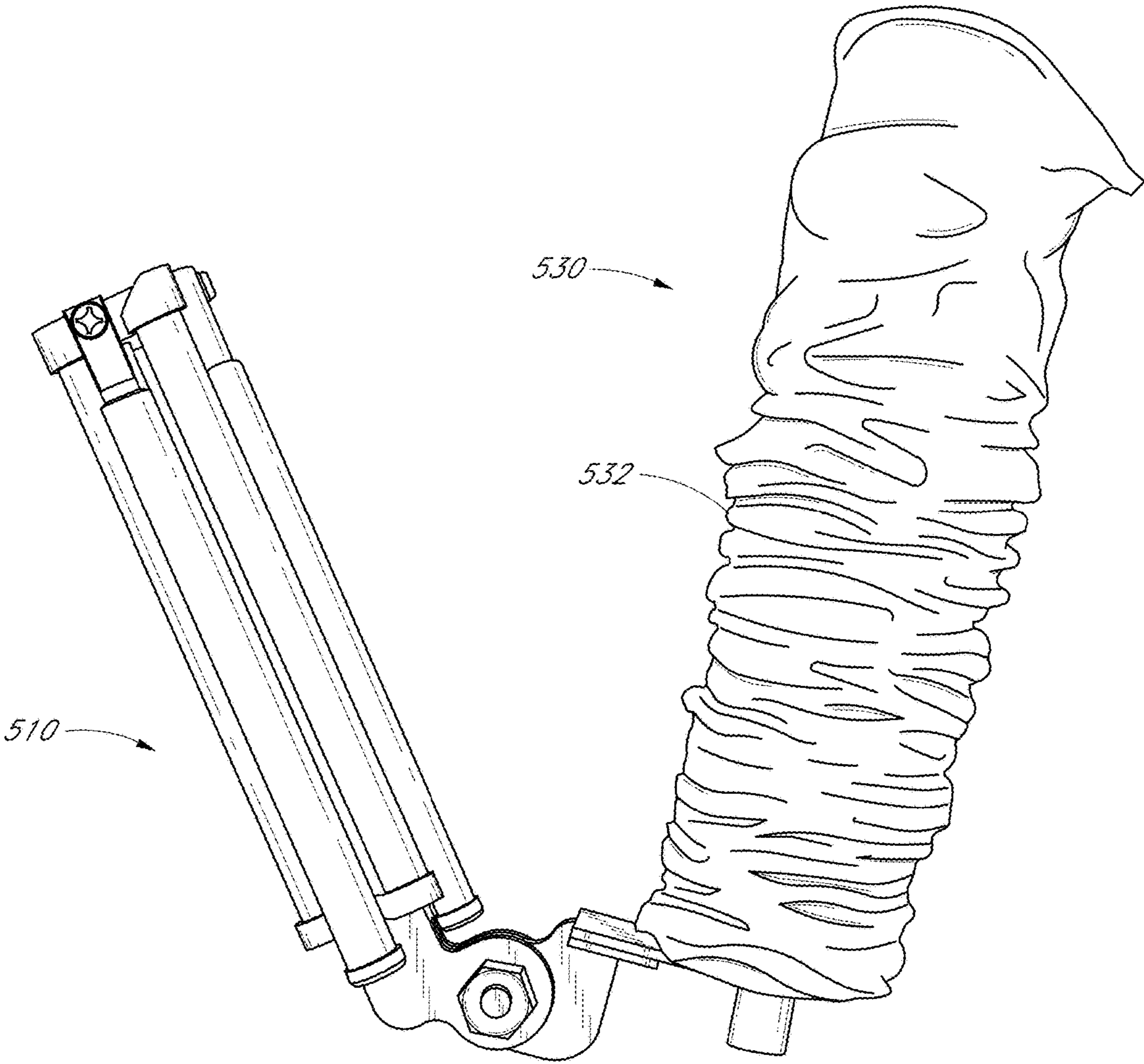

FIG. 13

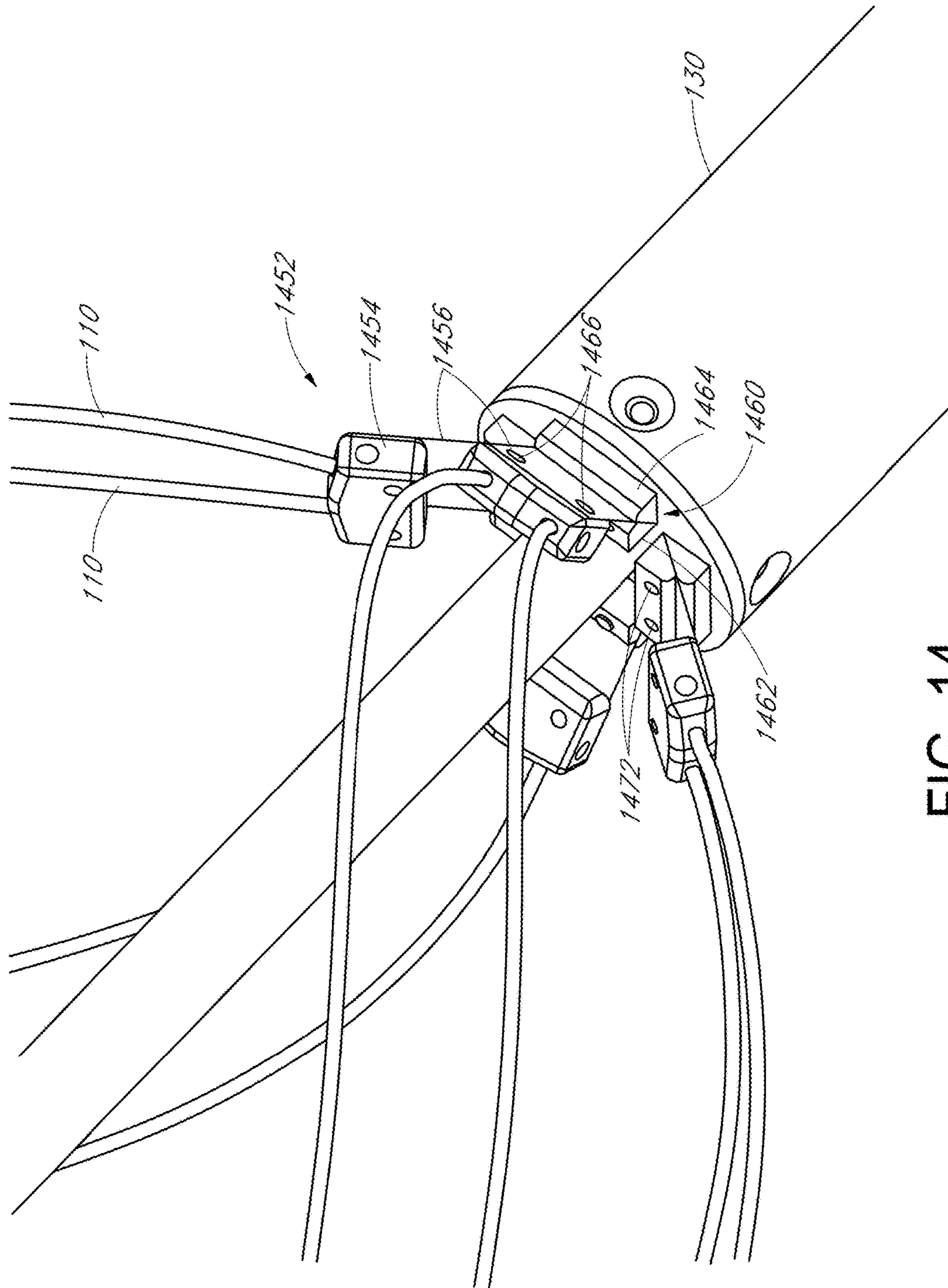

FIG. 14

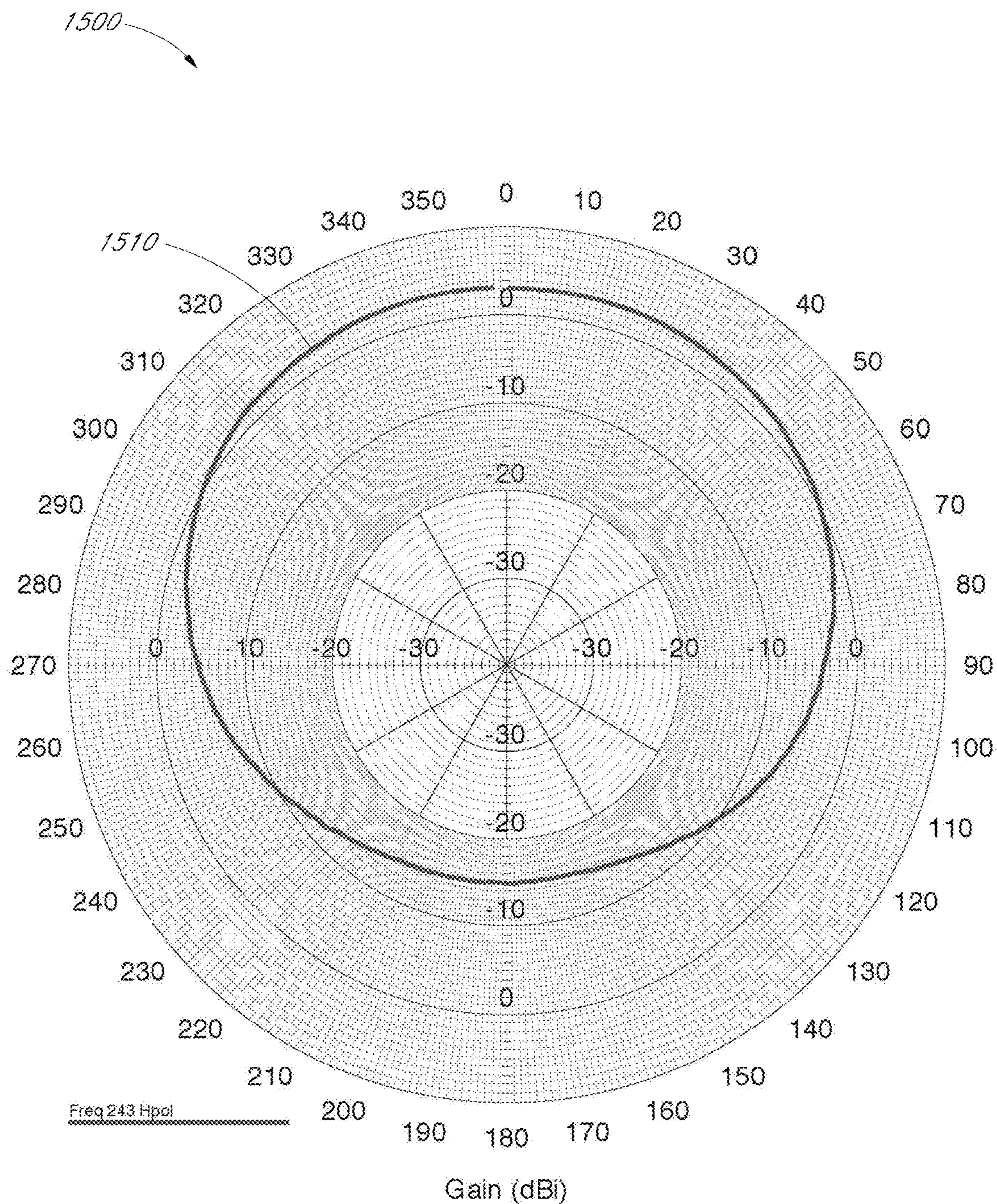

FIG. 15

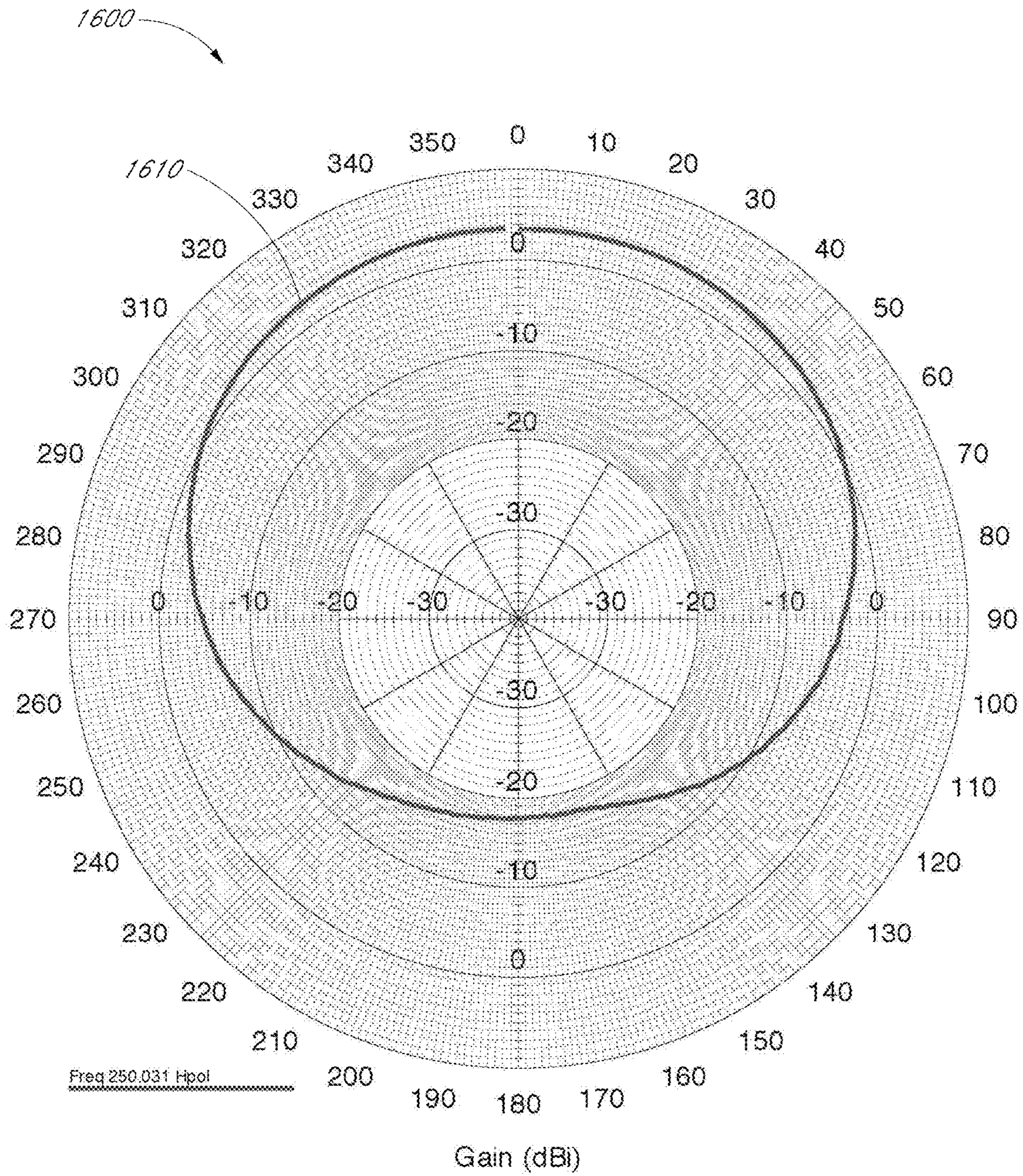

FIG. 16

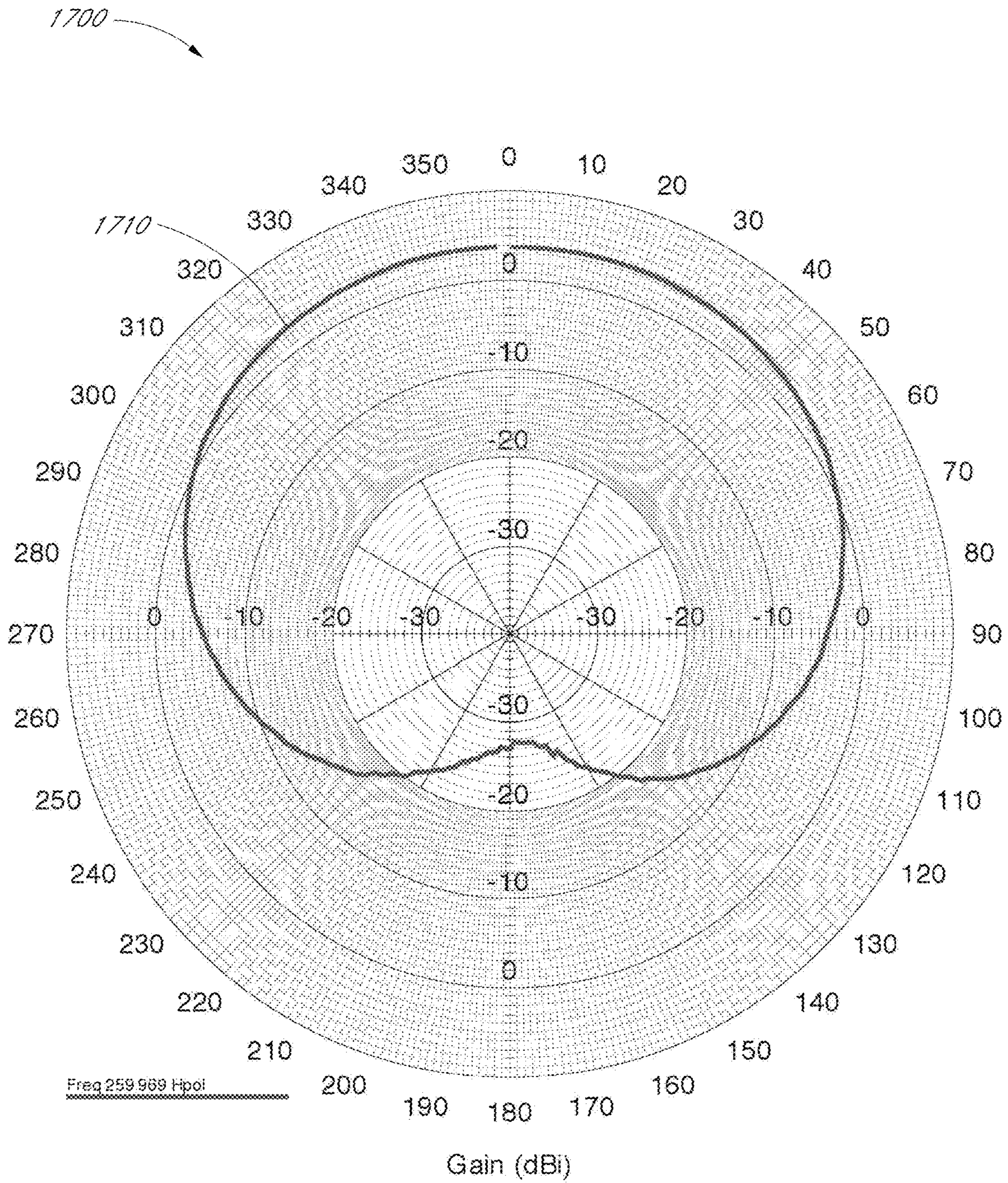

FIG. 17

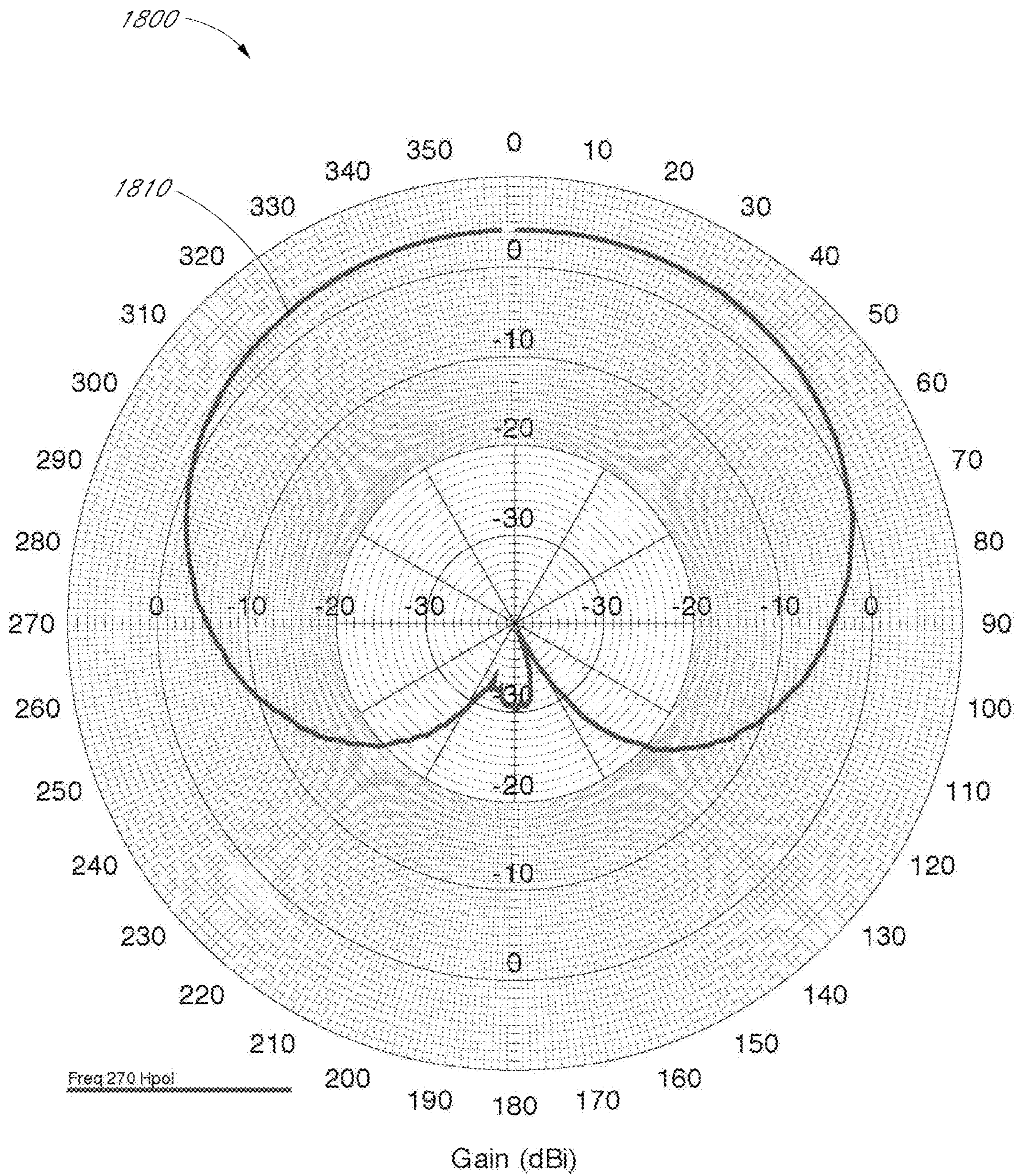

FIG. 18

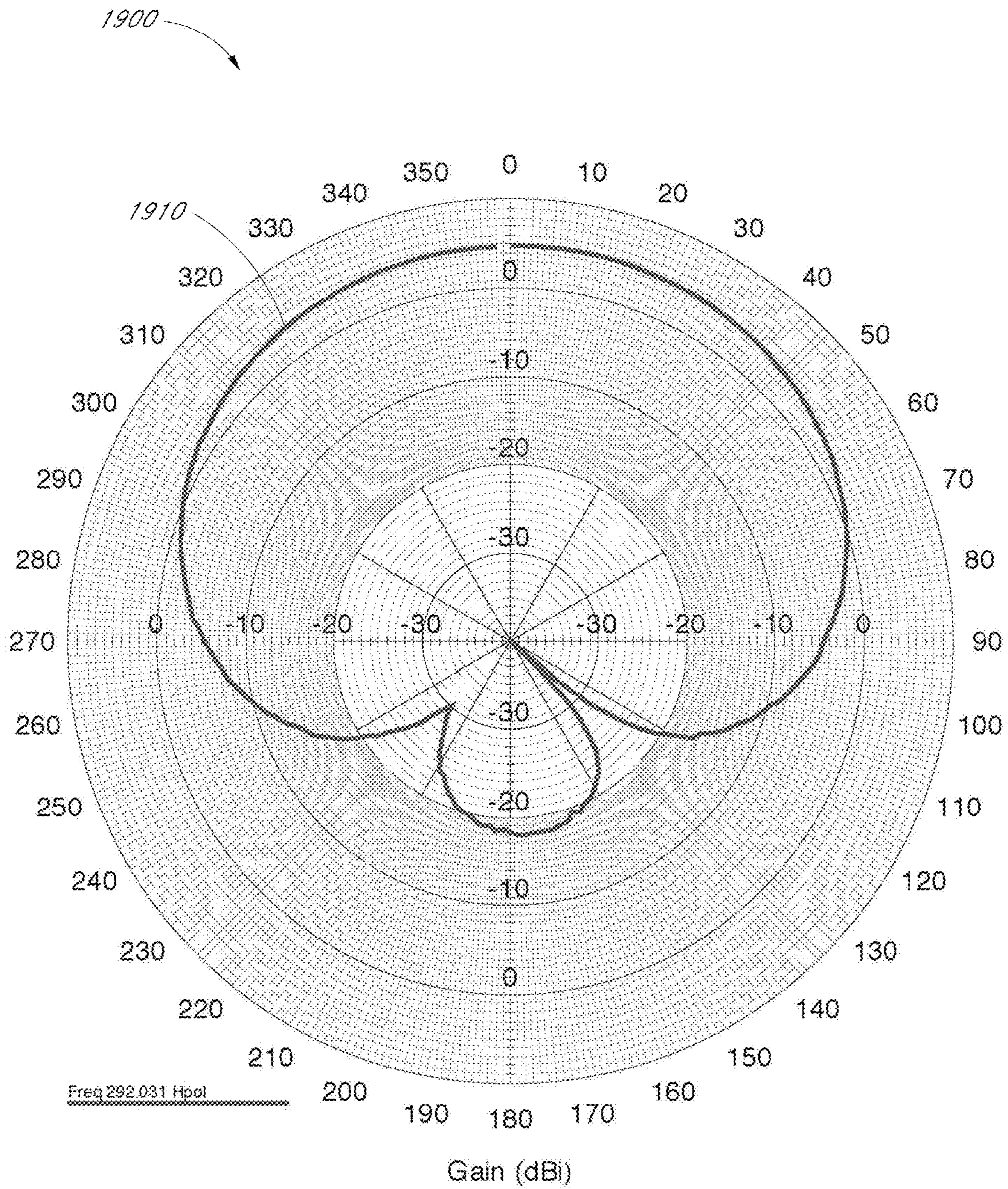

FIG. 19

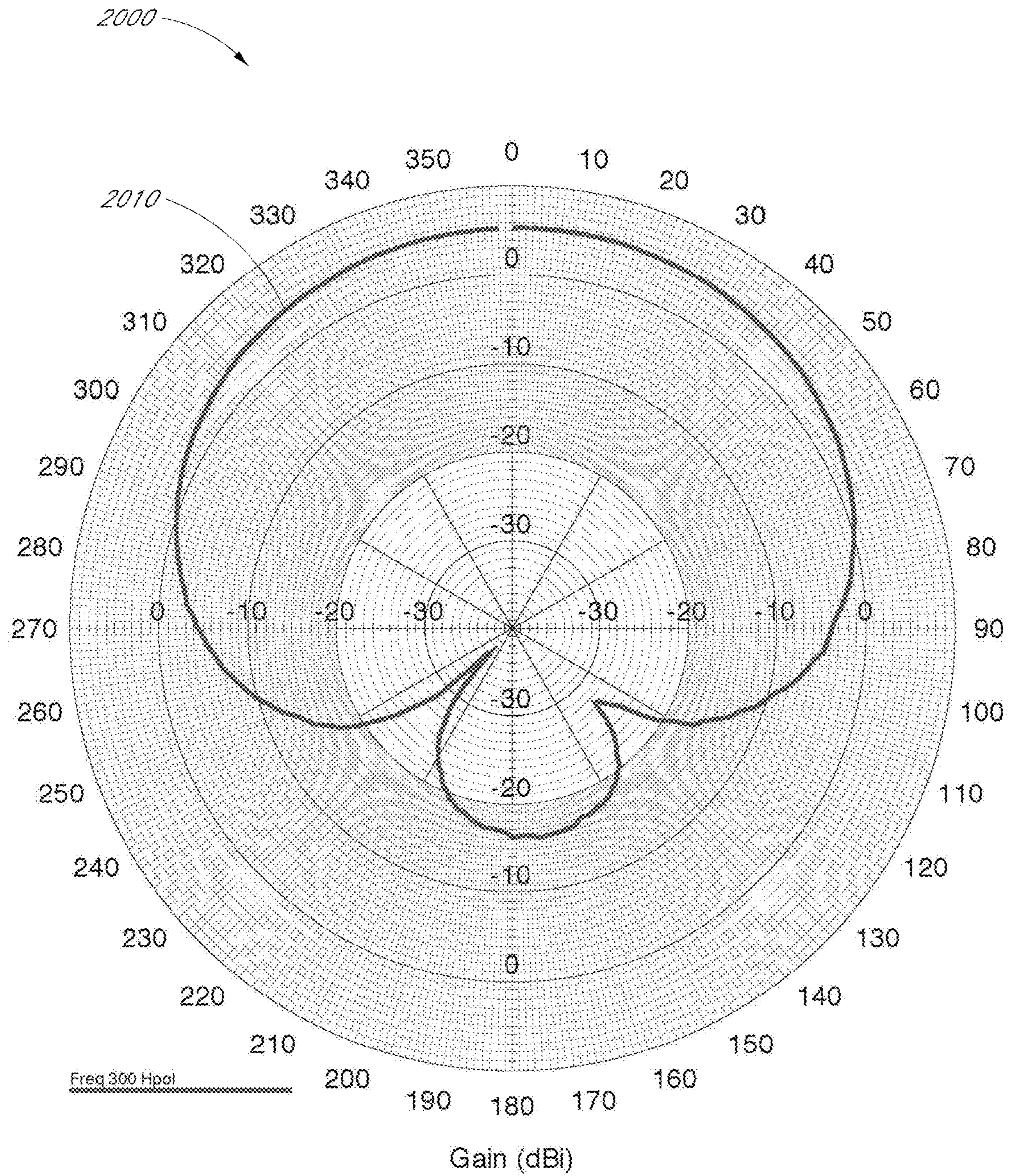

FIG. 20

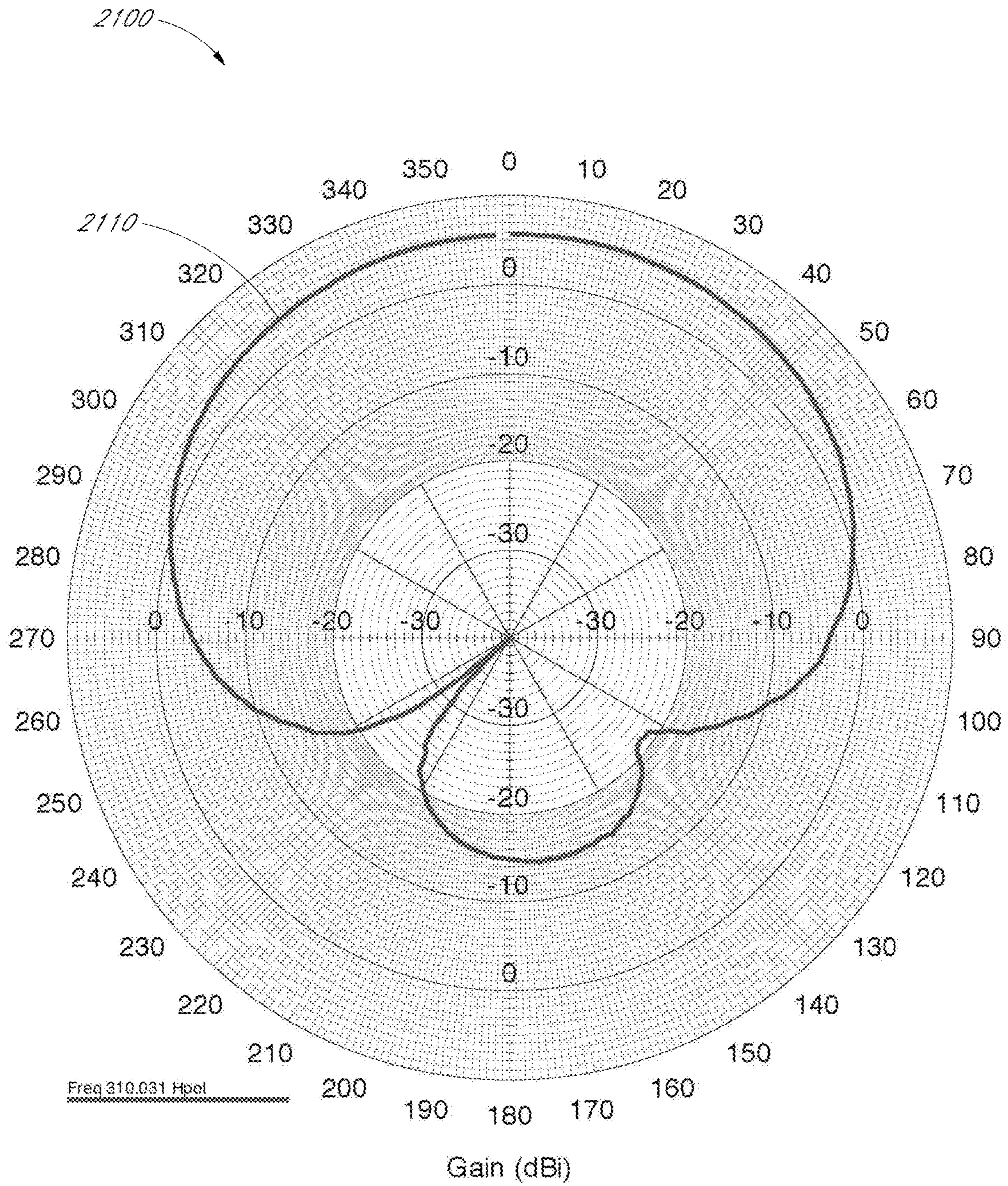

FIG. 21

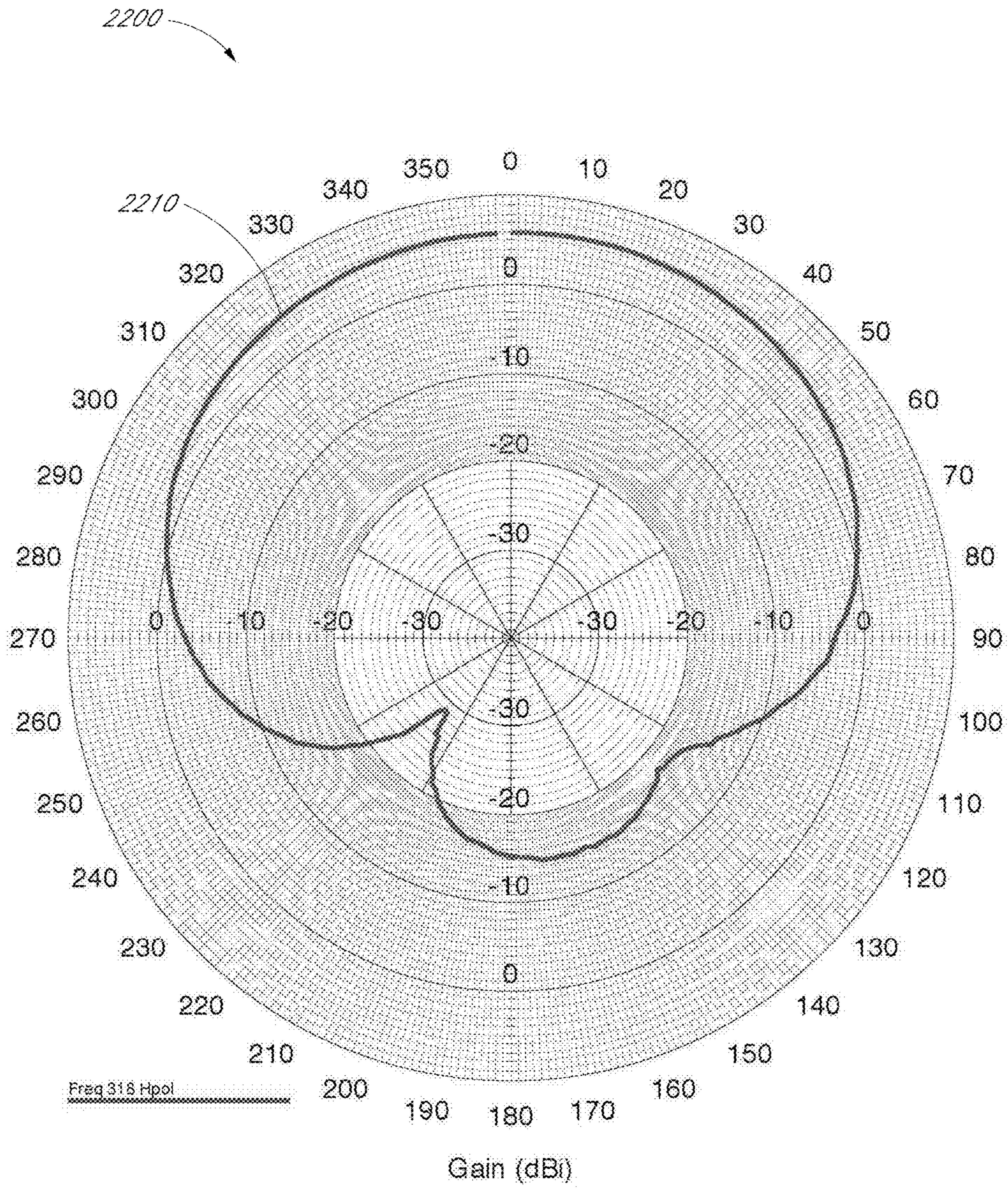

FIG. 22

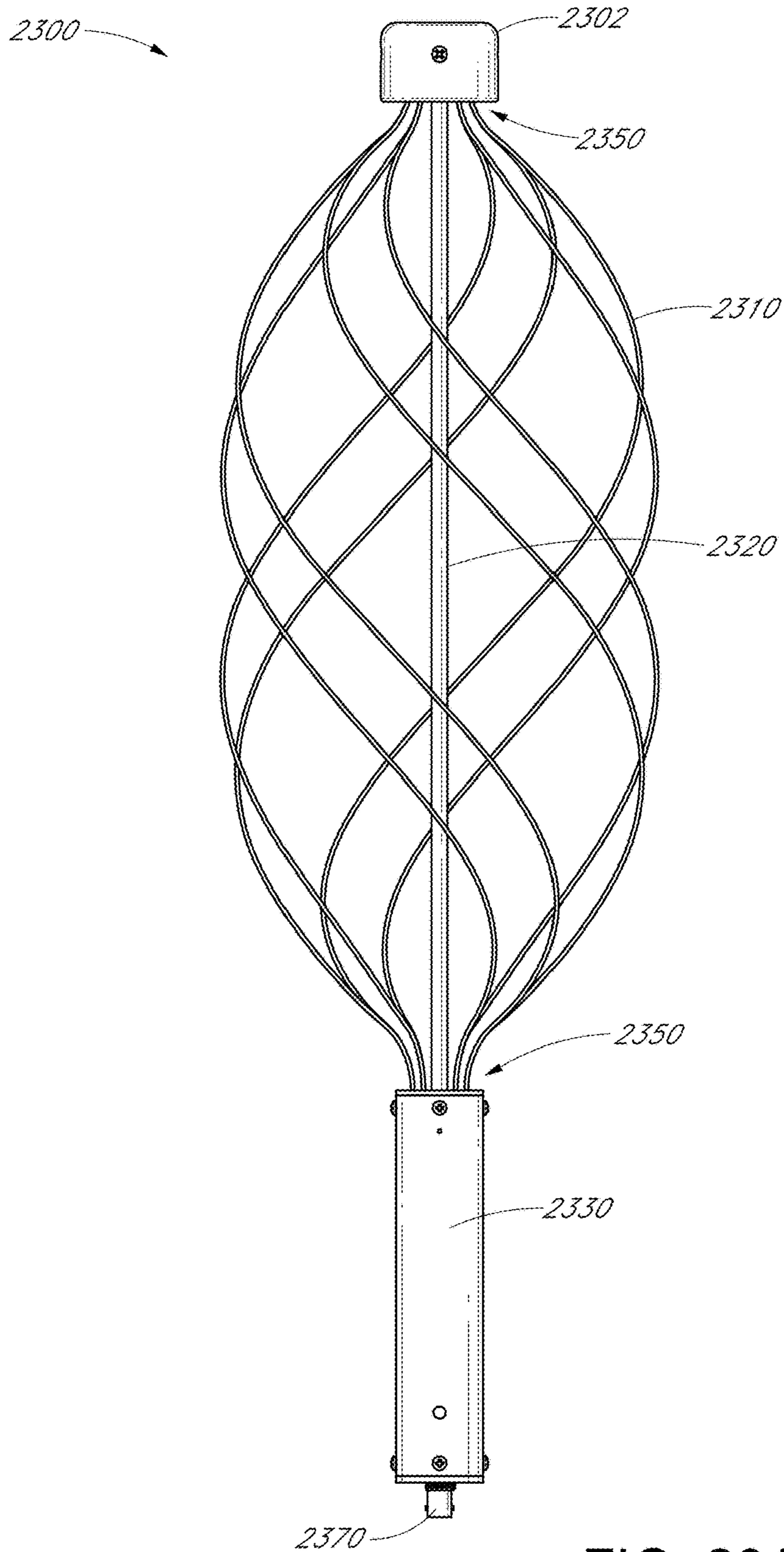

FIG. 23A

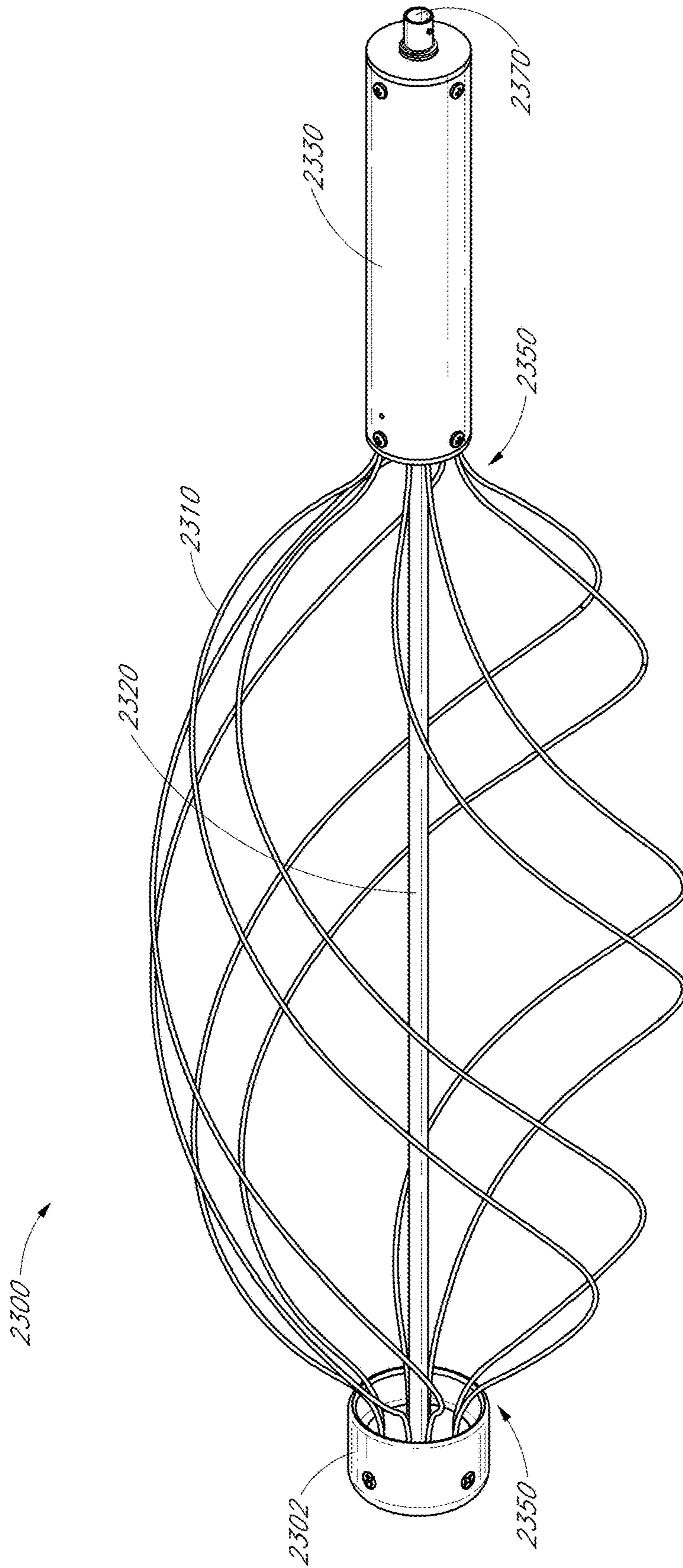

FIG. 23B

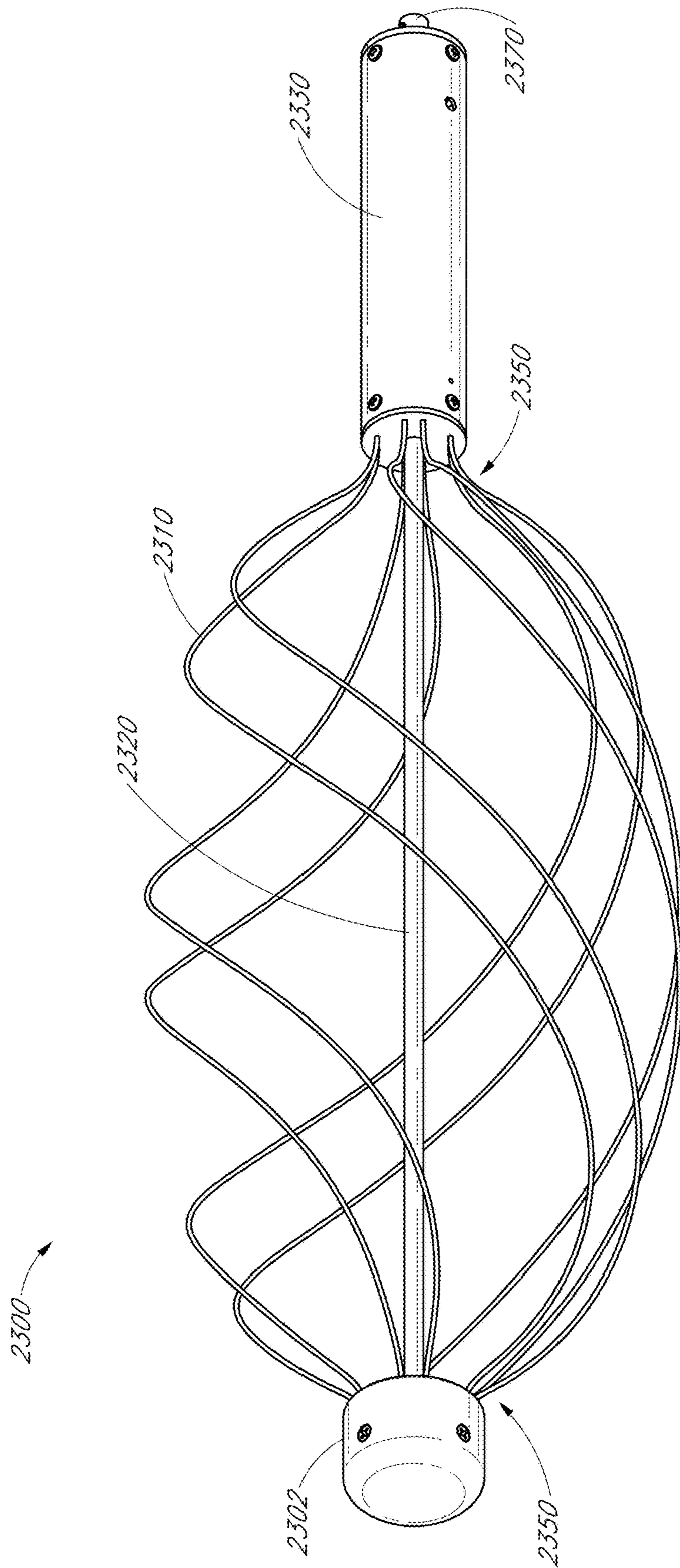

FIG. 23C

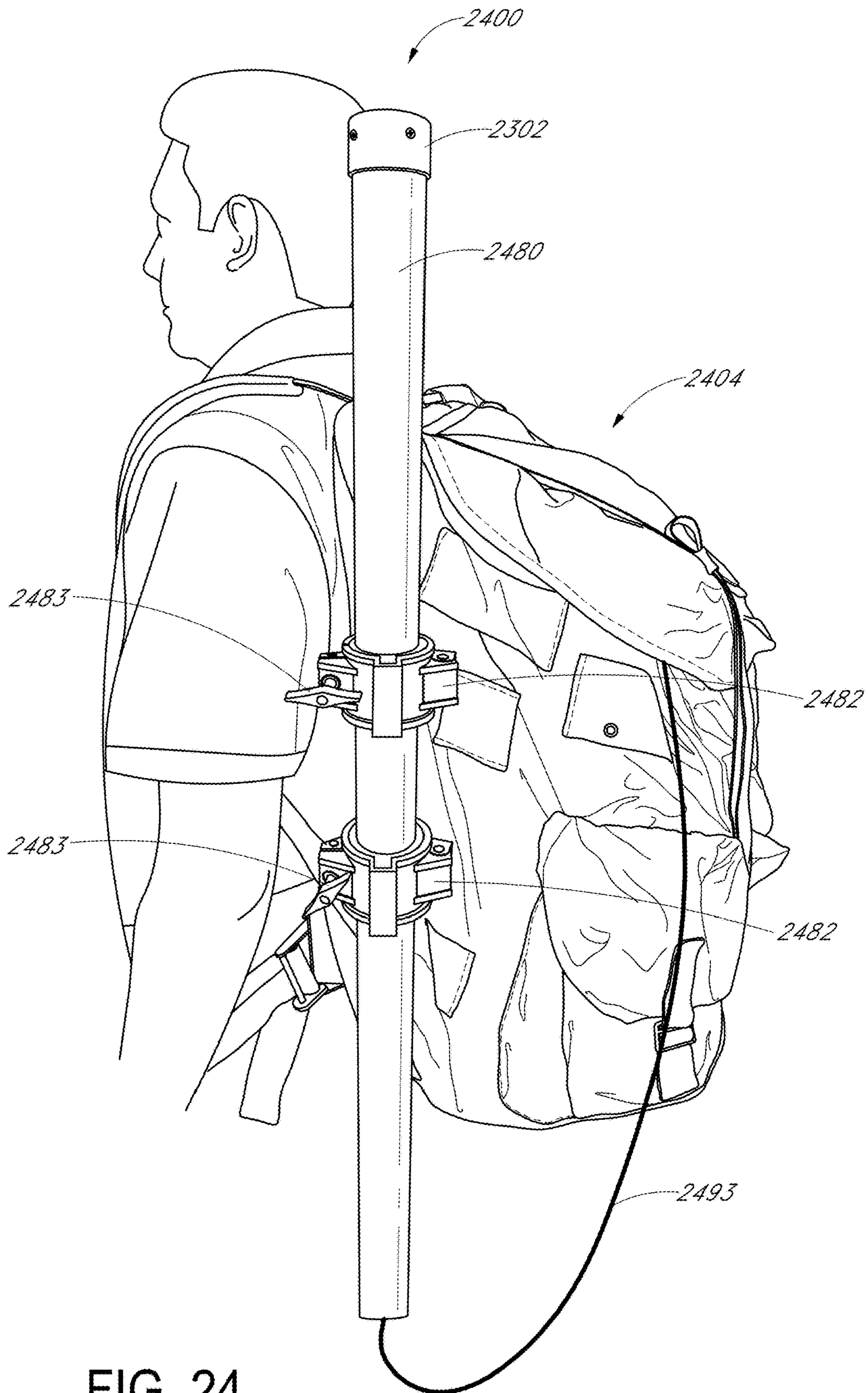
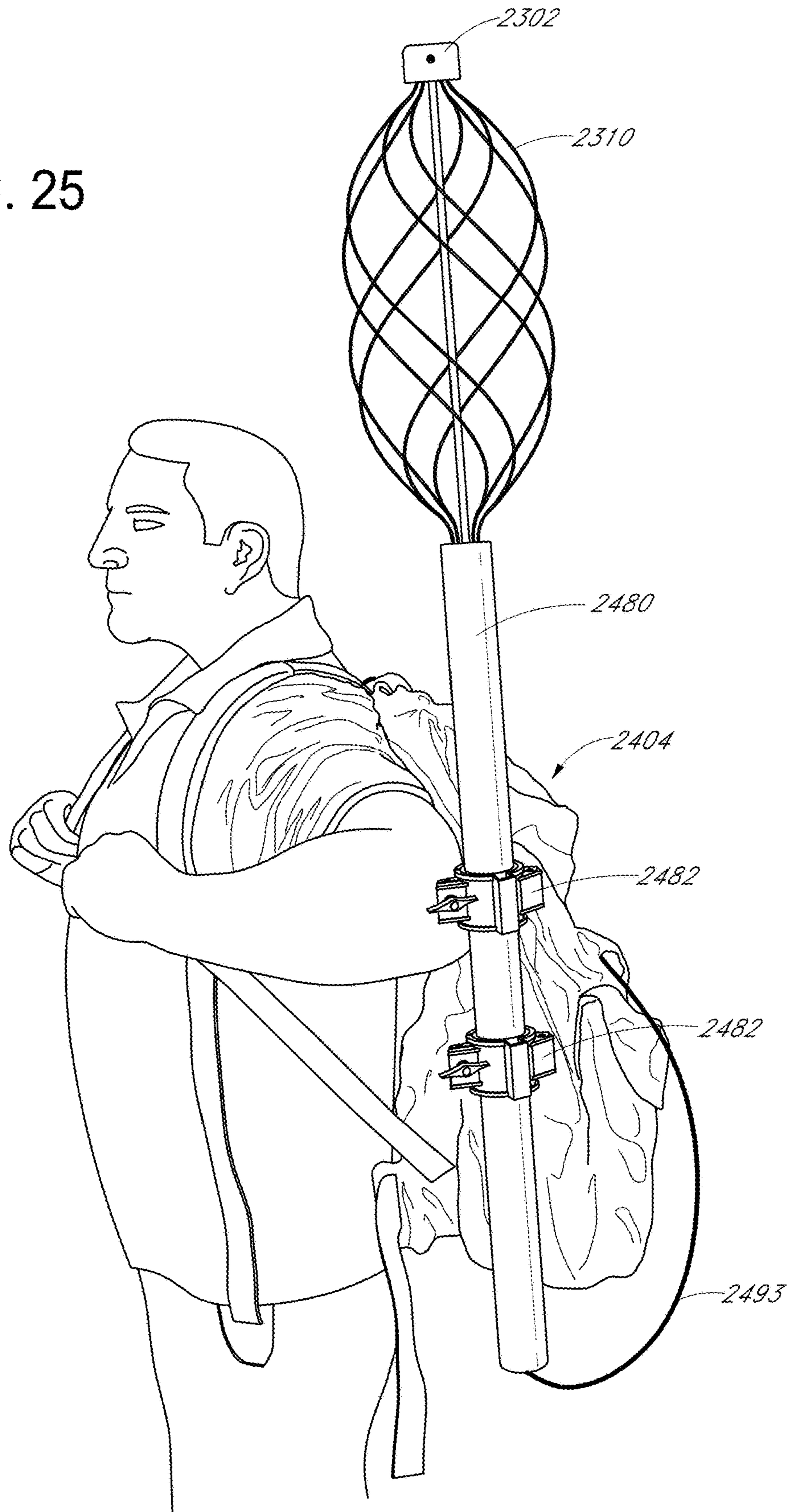

FIG. 24

FIG. 25



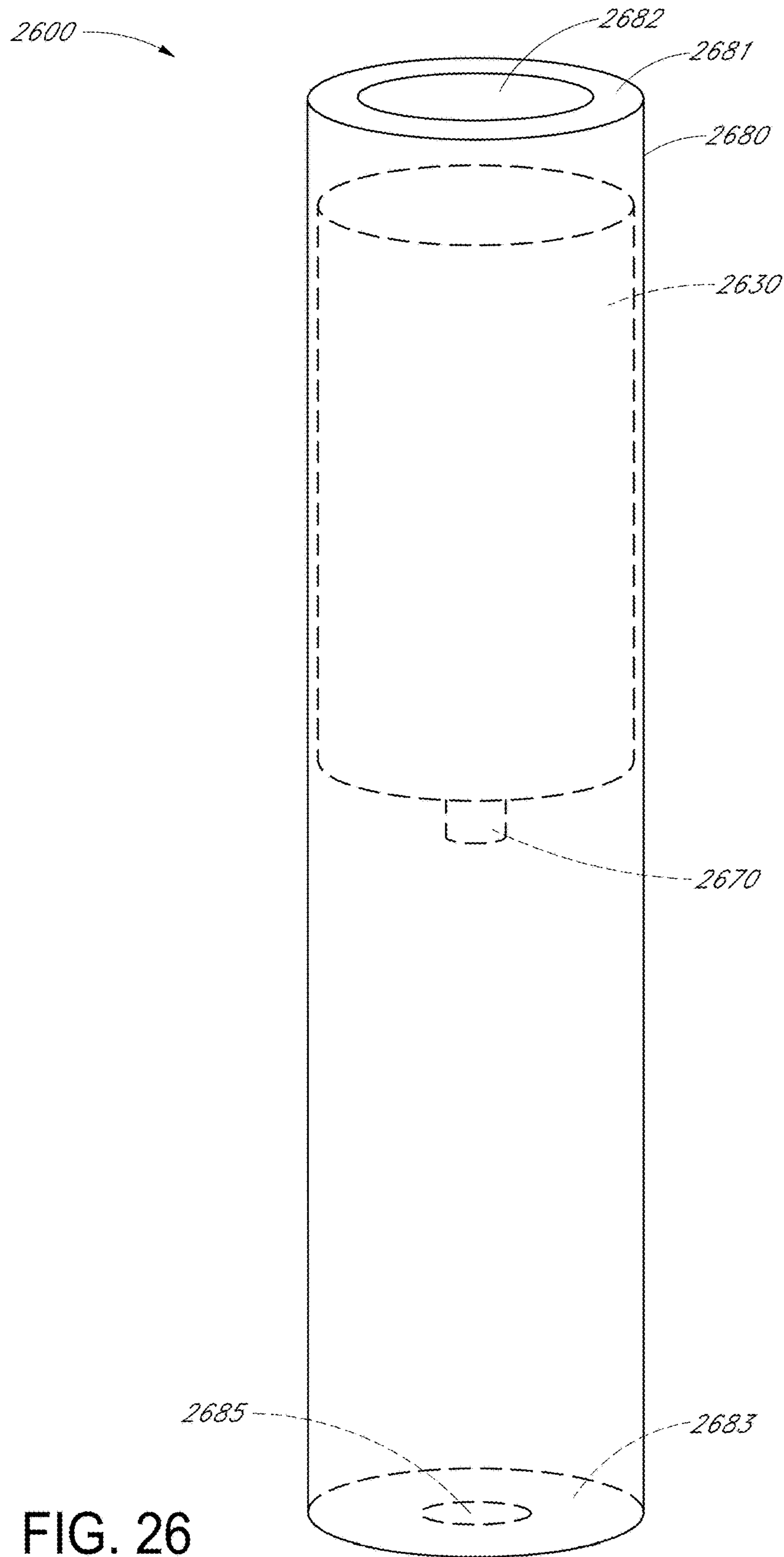

FIG. 26

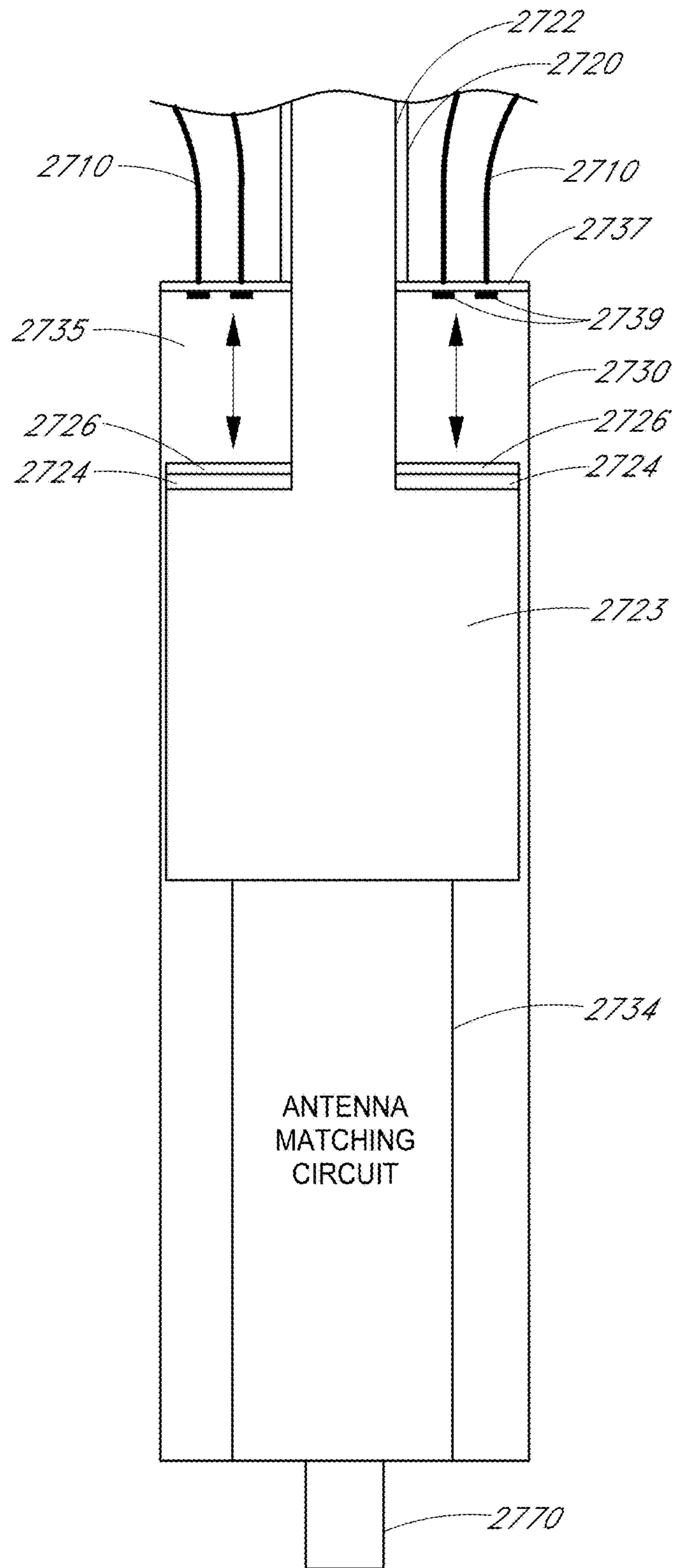

FIG. 27

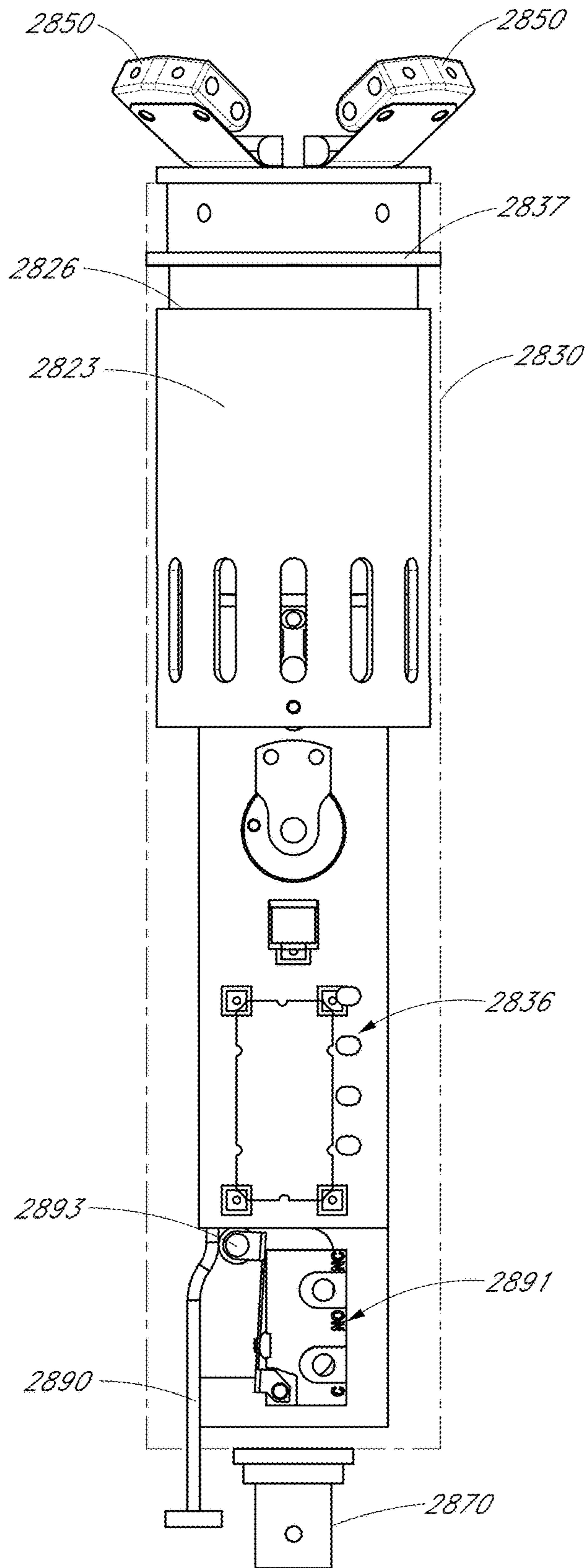

FIG. 28A

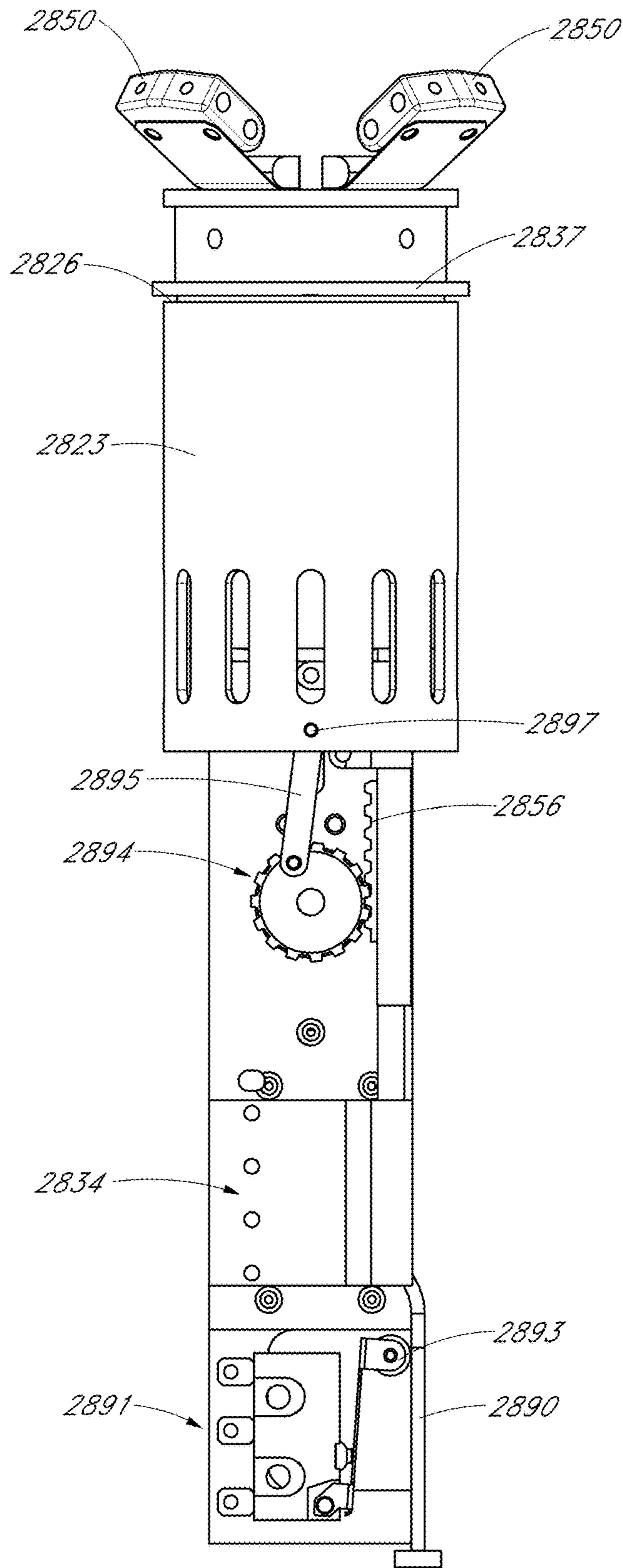

FIG. 28B

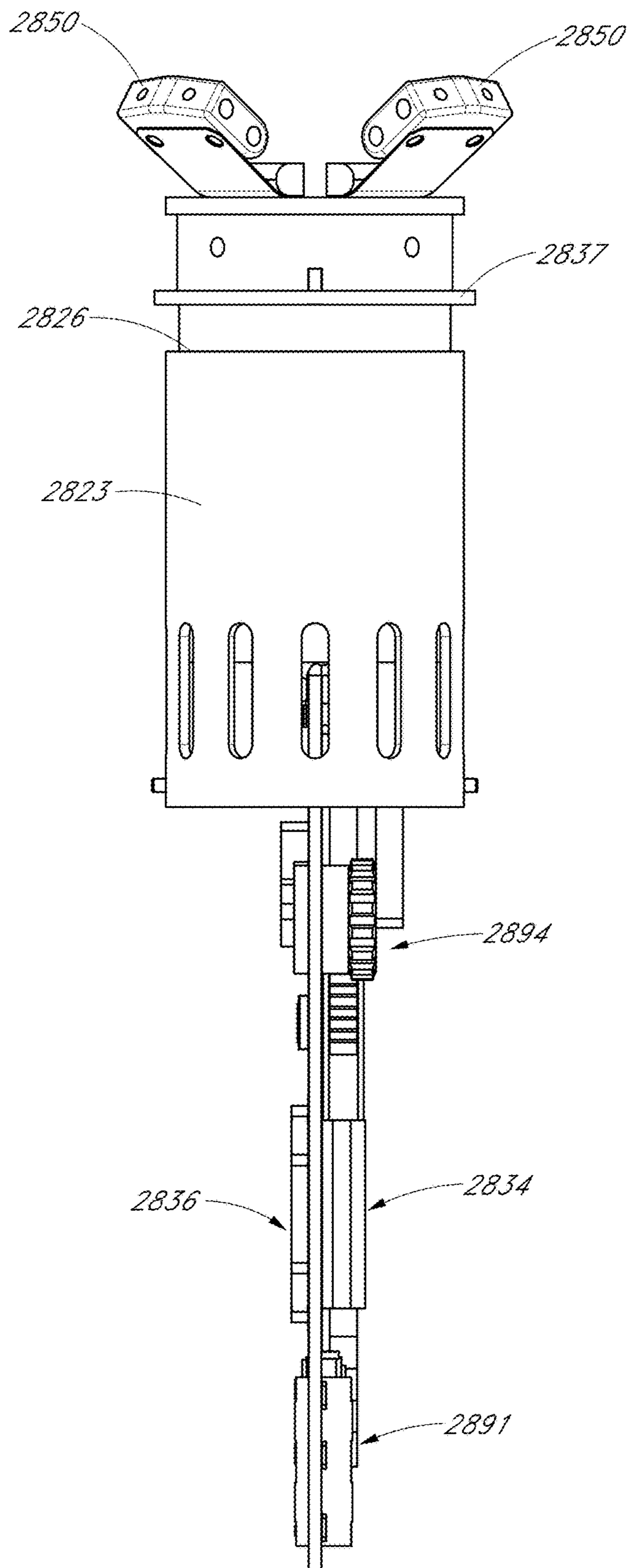

FIG. 28C

SOLDIER-MOUNTED ANTENNA

RELATED APPLICATION

This application is a continuation of U.S. patent application Ser. No. 13/762,836, entitled "SOLDIER-MOUNTED ANTENNA" and filed on Feb. 8, 2013, which is a non-provisional application of and claims priority to U.S. Provisional Application No. 61/597,621, filed Feb. 10, 2012, both of which are hereby incorporated by reference herein in their entireties.

BACKGROUND

Wireless communication using radios can be used for communications on land, in the air, at sea, or on opposite sides of the world. Communication from point to point on the ground is commonly accomplished with antennas such as monopoles or dipoles. A dipole, for example, has two elements approximately a quarter wave in length, arranged in a shared axial alignment configuration with a small gap between the two elements. Each element of the dipole can be fed with a current 180 degrees out of phase from the other element. A monopole has one element approximately a quarter wave in length, and operates in conjunction with a ground plane, which mimics the missing second element.

Monopoles and dipoles are generally used for line-of-sight (LOS) communications. Obstructions such as mountains, or long distances, relative to the curve of the earth's surface between the transmitter and receiver, can prevent the reception of LOS electromagnetic signals. The relative positions and heights of the transmitter and receiver, as well as the power output of the transmitter and sensitivity of the receiver determine the total successful communication distance for LOS.

To overcome LOS communication distance limitations, satellite communications (SATCOM) has been developed. Orbiting satellites have transceivers that can relay communications back and forth from the earth's surface or to other satellites, allowing communication virtually anywhere in the world.

SUMMARY

For purposes of summarizing the disclosure, certain aspects, advantages and novel features of the inventions have been described herein. It is to be understood that not necessarily all such advantages can be achieved in accordance with any particular embodiment of the inventions disclosed herein. Thus, the inventions disclosed herein can be embodied or carried out in a manner that achieves or optimizes one advantage or group of advantages as taught or suggested herein without necessarily achieving others.

In certain embodiments, an antenna includes a support structure and a plurality of spring-loaded antenna elements coupled with the support structure. The antenna elements can be movable from a collapsed first configuration to a deployed second configuration. In the first configuration, the antenna elements can radiate a substantially linearly-polarized electromagnetic radiation pattern, and in the second configuration the antenna elements can radiate a substantially circularly-polarized electromagnetic radiation pattern. As a result, the antenna can communicate line-of-site in the first configuration and with a satellite in the second configuration. Further, the antenna elements can expand in the deployed second configuration.

In certain embodiments, an antenna includes a support structure and a plurality of antenna elements supported by the support structure. The antenna elements can be expandable from a collapsed first configuration to an expanded second configuration. In the first configuration, the antenna elements can radiate a first radiation pattern, and in the second configuration the antenna elements can be expanded into a quadrifilar helix that can radiate a second radiation pattern different from the first radiation pattern.

In certain embodiments, an antenna can include a support structure and a plurality of spring-loaded antenna elements coupled with the support structure. The plurality of spring-loaded antenna elements can be movable from a collapsed first configuration to an expanded second configuration. In the first configuration, the antenna elements can radiate substantially linearly-polarized electromagnetic radiation, and in the second configuration the antenna elements can radiate substantially circularly-polarized or elliptically-polarized electromagnetic radiation.

BRIEF DESCRIPTION OF THE DRAWINGS

Throughout the drawings, reference numbers can be reused to indicate correspondence between referenced elements. The drawings are provided to illustrate embodiments of the inventions described herein and not to limit the scope thereof.

FIG. 1 is a front view of an embodiment of a dual-polarized antenna shown in a deployed configuration.

FIG. 2 is a top view of an embodiment of the dual-polarized antenna of FIG. 1.

FIG. 3 is a side perspective view of an embodiment of the dual-polarized antenna of FIG. 1.

FIG. 4 is a front view of an embodiment of the dual-polarized antenna shown in a collapsed linearly-polarized configuration.

FIGS. 5 through 7 illustrate conversion of the dual-polarized antenna from a collapsed linearly-polarized configuration to a deployed circularly-polarized or linearly-polarized configuration.

FIG. 8 illustrates an embodiment of a support structure that can be used by the dual-polarized antenna.

FIG. 9 illustrates a close-up view of an embodiment of a structure that can be used to connect movable elements of the antenna to a fixed portion of the antenna.

FIG. 10 illustrates an embodiment of the dual-polarized antenna mounted on a soldier in a collapsed LOS mode.

FIG. 11 illustrates an embodiment of a tripod base in an expanded configuration, which can be attached to a base of the dual-polarized antenna for use in certain embodiments when not deployed on a soldier.

FIG. 12 illustrates another embodiment of the tripod base of FIG. 11, in a collapsed configuration.

FIG. 13 illustrates an embodiment of the tripod base of FIGS. 11 and 12, connected to a base of the dual-polarized antenna.

FIG. 14 illustrates a close-up view of another embodiment of a structure that can be used to connect movable elements of the antenna to a fixed portion of the antenna.

FIGS. 15 through 22 illustrate example antenna radiation patterns that can be produced by embodiments of the dual-polarized antenna in SATCOM mode.

FIGS. 23A through 23C depict another embodiment of a dual-polarized antenna.

FIG. 24 depicts an embodiment of a tube case configured to cover the dual-polarized antenna, mounted on a soldier in a collapsed LOS mode.

FIG. 25 depicts the dual-polarized antenna in the tube of FIG. 24, mounted on a soldier in an expanded SATCOM mode.

FIG. 26 depicts another embodiment of a tube for the dual-polarized antenna.

FIG. 27 depicts an embodiment of a base of the dual-polarized antenna.

FIGS. 28A, 28B, and 28C depict another embodiment of a base of the dual-polarized antenna.

DETAILED DESCRIPTION

I. Introduction

One of the characteristics of electromagnetic wave transmission relates to polarization. Wave polarization describes what physical plane the electromagnetic wave is being transmitted in. A dipole or monopole oriented in a vertical position (e.g., perpendicular to the earth's surface) radiates electromagnetic waves with a vertical polarization. For a second antenna to receive strong signal strength, it too can have a vertical orientation. As the receiving antenna is rotated away from vertical, its receive power diminishes until the antenna reaches a horizontal orientation (perpendicular to the transmit antenna orientation), at which time the received signal strength can be reduced to a null. This condition can be referred to as cross-polarization.

As satellites orbit the earth, their attached antennas transmit and receive electromagnetic waves to and from multiple directions with various antenna orientations. To compensate for the unknown relative orientations between ground and satellite antennas, satellite antennas are often designed to transmit and receive electromagnetic waves that are circularly polarized. The polarization of a transmitted radio wave is determined in general by the transmitting antenna physical shape (geometry) and feed type and its orientation. A circularly polarized electromagnetic wave signal is transmitted in a continuous right-hand or left-hand rotating orientation. One form of circularly polarized antenna has two dipoles arranged orthogonal to one another. The dipoles can be each equally driven by the radio with one driven by the waveform that is 90 degrees out of phase with the other. When viewed on a three-dimensional time vs. polarization graph, the circularly polarized signal resembles a spiral helix.

Due to the above-mentioned problem of cross-polarization, a linearly polarized ground antenna can suffer from a 50% signal loss when transmitting or receiving a satellite circularly polarized communication signal. To solve this signal loss problem, the ground antenna can advantageously also be a circularly polarized antenna to increase efficiency when used to transmit to or receive from a satellite.

Soldiers wish to communicate reliably and efficiently with others on land, in the air, at sea, or on opposite sides of the world. For such purposes, soldiers typically carry small tactical radios. Such tactical radios are mobile radios designed to be carried or worn on a person. Currently, soldier radios are used both on the move and at halt. These radios can have capabilities to utilize both a circular polarized antenna for satellite communication (SATCOM) and a linear polarized antenna for line of site (LOS) communications.

As described above, both linearly polarized antennas and circularly polarized antennas are known. However, carrying two separate antennas is cumbersome, especially for a soldier. Disconnection of the LOS antenna and connection of the SATCOM antenna is burdensome. Also, most SAT-

COM antennas require significant time for assembly or disassembly and are not suitable for use on the soldier on the move.

In the interests of convenience, utility and cost, it can be beneficial to provide a portable, lightweight, dual polarization, LOS/SATCOM antenna in the form of a single unit that can be soldier mounted and rapidly deployed from LOS configuration to the SATCOM configuration in the field.

Embodiments of antennas described herein can be mounted multi-purpose antennas for soldier (or civilian) use. These antennas may be transported or utilized in a compact configuration as a linear polarized omnidirectional LOS antenna and then quickly re-configured to be in a geometric shape for a circular polarized omnidirectional antenna for use for SATCOM. It should be understood that as used herein, the term "omnidirectional," in addition to having its ordinary meaning, when applied to antennas can refer to a pattern of radiation that has substantially low directivity and not necessarily an isotropic radiator. For example, a dipole or monopole LOS antenna may radiate in all or substantially all directions in an azimuthal plane perpendicular to the dipole and thus radiate "omnidirectionally," although a null may exist at the zenith of the radiation pattern. Similarly, embodiments of an antenna in a SATCOM configuration also radiate circular polarization omnidirectionally or substantially omnidirectionally, including in the zenith direction.

Such antennas can provide a soldier with a mountable, portable, easily transformable, dual polarization radio antenna. The dual-polarization antenna can be quickly deployed to either a circular polarization (CP) mode or a linear polarization (LP) mode. The antenna can include elements that can be expanded to achieve CP or LP mode. In the expanded configuration, the elements can radiate in the CP or LP mode, whereas in the collapsed configuration, the elements can radiate in an LP mode.

These and other purposes are achieved in certain embodiments by a portable supporting structure for a multi-element antenna formed by multiple folding elements pivotally connected to the mast. The mast base can be supported by an attachment structure that can be held into place by one or more fabric loops or pockets typically sewn to the backpack or vest webbing (among other possible attachment points). The fabric loops can allow for holding items such as the antenna support structure. The antenna system can then be fixed in a specific orientation or pointing in a satellite direction while mounted on the soldier. Alternatively, the antenna system can be held in a soldier's hand. The mast base may optionally connect to a tripod for deploying the antenna on the ground or other surface.

Embodiments of the antenna described herein can be considered either a dipole or a monopole in LP mode. In one embodiment, the antenna acts electrically like a dipole in which the radiating elements (deployed or collapsed) act as a monopole while other aspects of the antenna (such as the handle), the cable, and/or the radio or user act as a counterpoise to the monopole. Furthermore, in certain embodiments, the antenna described herein is not two antennas, but a single antenna having two (or more) communication modes.

II. Dual-Polarized Antenna Overview

Referring to the Figures, FIGS. 1 through 3 illustrate aspects of an embodiment of a dual-polarized antenna 100. In particular, FIG. 1 illustrates a front view of the antenna 100, FIG. 2 illustrates a top view of the antenna 100, and

5

FIG. 3 illustrates a side perspective view of the antenna 100. The antenna 100 may be connected to an article of clothing, such as a soldier's vest or backpack, or may be handheld. Advantageously, the antenna 100 can be quickly and easily switched by a soldier on the move to radiate with substantially linear polarization or substantially circular (or elliptical) polarization.

The example antenna 100 shown includes a support structure having an end cap 102, a mast 120, and a base 130 (among possibly other components). Antenna elements 110 are attached to the support structure via pivot elements 150. In the example configuration shown, the antenna elements 110 can radiate with circular polarization, suitable for satellite communications. For convenience, this configuration is referred to herein as the deployed configuration. The antenna elements 110 can be collapsed or folded against the mast 120 to be transformed into a linearly polarized antenna, suitable for line-of-site communications (see, e.g., FIG. 4). In some cases, described below, the deployed configuration can also be suitable for LOS as well as SATCOM (at potentially some performance penalty over the collapsed LOS mode).

The antenna elements 110 can be collapsed and folded against the mast 120 due in part to pivoting action of the pivot elements 150 and stored against the mast 120 by application of a slip cover of a larger diameter than the base 130 (refer to FIGS. 4 through 6) or other mechanism (see, e.g., FIGS. 23A through 23C). The antenna elements 110 can remain positioned closely or relatively closely around the mast 120 while the antenna is in the collapsed configuration. The pivot elements 150 allow the antenna elements 110 to pivot when the elements 110 are moved toward or away from the mast 120, thereby enabling the antenna 100 to change from a collapsed configuration to a deployed configuration and vice versa.

The antenna elements 110 can be spring-loaded or manually-shaped by a user. Spring-loaded antenna elements 110, however, can advantageously allow for easier deployment of the collapsed elements 110 and holding of the deployed elements 110 in a geometric shape suitable for circular polarization. As seen in FIG. 1, in some embodiments, the antenna elements 110 are formed in a quadrifilar helix shape. Unlike existing quadrifilar helix antennas, however, the antenna elements 110 of the antenna 100 do not necessarily terminate in 90-degree angles at the top and base of the elements in some embodiments. Instead, the antenna elements 110 curve into the pivot elements 150, forming (together as a group) an ellipsoid, ovaloid, or football-like shape. This shape can advantageously provide excellent circular polarization characteristics while also allowing easier collapsing of the antenna elements 110 into the LOS configuration. Quadrifilar elements with 90-degree angles, in contrast, would be difficult to collapse against the mast 120. However, such 90-degree elements can be used in some embodiments, optionally with hinges or other flexure elements (such as springs) at the 90-degree angle points to facilitate collapsing the elements.

The quadrifilar antenna 100 shown can provide ease of use and comfort advantages over other circularly polarized antennas, such as crossed Yagis. Crossed Yagis can be more difficult or slower to deploy, with some antennas having separate parts that must be assembled. Crossed Yagis typically have reflector elements that can make for difficulty in mounting the antenna on the soldier. The quadrifilar antenna 100 can avoid these assembly problems, as the antenna 100 can be carried preassembled by a soldier. In addition, the antenna 100 can be lightweight and compact in the collapsed

6

position, which may be a welcome change for soldiers who already typically carry 50-60 pounds of equipment. Further, crossed Yagi elements held by a soldier or attached to a soldier's clothing can snag on the soldier's clothing or dig into the soldier's body. In contrast, the elements 110 of the antenna 100 may be less prone to snag and have no elements that may protrude uncomfortably into a soldier.

Radiation from a quadrifilar helix antenna can be circularly or elliptically polarized. In some embodiments, the quadrifilar antenna elements 110 include two bifilar helical loops oriented in mutually orthogonal relation on a common axis (e.g., the mast 120). In some embodiments of SATCOM mode, the terminals or ends of each loop can be fed with signal current that is 180° out of phase, and the current in the two loops can be in phase quadrature (e.g., 90° out of phase). In contrast, in the LOS mode, each of the pairs of elements 110 can be driven together in phase as if the elements 110 were one lumped conductor, thereby achieving a dipole configuration (see, e.g., FIGS. 27 through 28C).

By selecting the appropriate shape of the helical loops in SATCOM mode, a wide range of radiation pattern shapes is available. In various embodiments, the geometric shape of each antenna element 110 may be a wire spiral helix element following the surface of an ellipsoid, a cylinder, a sphere, or an ovaloid. In some embodiments, the antenna elements 110 may each comprise a pair of closely spaced thin metal spiral helix elements following the surface of an ellipsoid, a cylinder, a sphere, or an ovaloid. In other embodiments, the antenna elements 110 may each comprise two, four, six, eight, or other number of pairs of closely spaced thin metal spiral helix elements. The spiral helix elements can be configured to spiral through an amount of twist of about 90° to about 270° over the ellipsoid, cylindrical, or spherical surfaces. An odd number of antenna elements may be used in some configurations of the antenna 100.

The pair of wires in each antenna element 110 can be driven together, in phase, in certain embodiments. For example, each wire in a pair can be electrically connected to the other wire in the pair. Using pairs of wires for the antenna elements 110 can have advantages over other configurations. The parallel or substantially parallel wires can effectively act as a larger conductor, thereby having a lower Q factor than a single, smaller conductor. This lower Q factor can facilitate easier impedance matching over a wider range of frequencies than if a single or smaller conductor were used for each element. Having a wide frequency range can facilitate using the antenna 100 in both LOS and SATCOM modes over a wide range of military (or other) frequencies. However, in other embodiments, blade conductors or single wires can be used in place of the paired wire antenna elements 110.

Additional practical benefits of using conductor pairs instead of larger conductors (such as blades) can include reduced carrying weight and lower visibility, both useful attributes for soldiers. The visibility of the antenna 100 can further be reduced by painting the antenna 100 (including the elements 110) black or camouflage.

In various embodiments, the antenna elements 110 may be produced using pre-shaped or shapeable nickel titanium (NiTi or nitinol) alloy memory metal. An example process for shaping the memory metal is described in greater detail below. Using such materials, the antenna elements 110 can be stored in a minimal profile geometric configuration when collapsed along the mast and can hold the SATCOM or LOS geometric configuration when deployed out from the mast 120. In some embodiments, the material used to produce the antenna elements 110 may include copper, iron, niobium,

hafnium, cobalt, nickel-titanium cobalt, combinations of the same, or the like. In other embodiments, the material may also include alloys of superelastic memory metal, such as any combination of the following: AgCd, AuCd, CuAlNi, CuSn, CuZn, InTi, NiAl, FePt, MnCu, and FeMnSi. In yet other embodiments, the material may also include spring steel or beryllium-copper. In another embodiment, the material can be or include piano wire. Any combination of the materials described herein can be used to produce the antenna elements **110**.

The base **130** can include a switch mechanism (not shown), which can be used to select impedance matching for either LOS or SATCOM (see, e.g., FIGS. **8**, **27**, and **28**) when the antenna elements **110** are expanded from the mast **120**. The switch mechanism can be configured to switch between two antenna impedance matching circuits based on desired use: one matching circuit for the circularly polarized configuration and one matching circuit for the linear polarization configuration. An electrical connector **170** at the bottom of the base **130** can be connected by a cable, such as a coax cable, to a radio for transmission/reception. One example type of electrical connector **170** that can be used is a BNC connector, although other connector types may also be employed. The electrical connector **170** may also be placed in another location of the base **130** other than the bottom thereof.

The mast **120** may be made of a rigid or semi-rigid material to support the antenna. In some embodiments, however, the mast **120** is omitted as the antenna elements **110** may be rigid enough to substantially hold their shape in either the collapsed or deployed configuration. The antenna elements can be designed to have sufficient thickness to provide enough rigidity to hold their shape in either configuration.

As mentioned above, FIG. **4** depicts an embodiment of the antenna (**200**) shown in a collapsed linearly-polarized LOS configuration. In this embodiment, the antenna **200** includes a slip cover **280** that covers or at least partially covers the antenna elements **110** and mast **120** shown in FIGS. **1-3**. With the slip cover **280** covering the antenna elements **110**, the elements **110** are collapsed against the mast **120** and therefore form a substantially cylindrical structure that can radiate with linear or substantially linear polarization.

The slip cover **280** may be attached to the base **130**, for example, at the bottom of the base **130**, and optionally extend up to the top of the antenna **100** above the end cap **102**. The slip cover **280** may cover less than the full length of the antenna **100** in some embodiments. Further, the slip cover **280** may be detached from the antenna **100** or attached at the top of the antenna (e.g., at the end cap **102**) in other embodiments. The slip cover **280** is an example of a tube, and in particular, a soft tube or fabric tube, that can at least partially cover the antenna elements **110**. The slip cover **280** can be a nylon material or other material that is water resistant in some embodiments. An example hard tube that can cover the elements **110** is described below with respect to FIGS. **24** through **26**. In some embodiments, the covering of the antenna elements **110** (and optionally base **130**) can include any combination of materials, hard and soft, and can be considered a cover, tube, sheath, case, or the like.

The antenna elements shown in FIG. **4** are twisted and collapsed against the mast **120** and therefore bear some resemblance to a dipole or monopole. However, the twisted shape of the elements **110** around the mast **120** also has some differences from the appearance of a straight dipole. Regardless of these differences in appearance, the antenna elements can still act electrically as a dipole (or monopole), radiating

a pattern similar to that of a dipole (or monopole). Thus, in addition to having their ordinary meaning, terms such as “dipole” and “monopole,” as used herein, can refer to antenna structures that have similar radiation patterns (or polarization) to a dipole or monopole even though their mechanical structure differs in some respects from some dipoles or monopoles.

III. Collapsed LOS to Deployed LOS OR SATCOM Mode Conversion

The slip cover **280** shown in FIG. **4** can be slipped off of or otherwise removed from the antenna elements **110** to allow the antenna elements **110** to resume a quadrifilar helical shape. The antenna elements **110** can automatically assume the quadrifilar helical shape in some embodiments because the elements **110** are spring-loaded and pivotably attached to the support structure via pivot elements **150**. However, the pivot elements **150** are also optional in some embodiments (see, e.g., FIGS. **23A** through **23C**). FIGS. **5** through **7** illustrate conversion of the antenna **200** from a collapsed linearly-polarized LOS configuration to a deployed circularly-polarized SATCOM (or also optionally linearly polarized) configuration.

Referring to FIG. **5**, the slip cover **280** is shown being pulled down from the antenna by a user's hands, exposing the end cap **102** of the antenna **200**. As the slip cover **280** is pulled farther down toward the base **130**, the antenna elements **110** and mast **120** are also exposed. Further, the antenna elements **110** expand as the slip cover **280** is uncovers them in certain embodiments. In FIG. **7**, the slip cover has been substantially removed from the antenna elements **110**, thereby allowing the antenna elements **110** to spring open into a quadrifilar helical shape. The slip cover **280** can also be completely removed from the base **130** of the antenna **100** as well in some embodiments. In other embodiments, the slip cover **280** is attached to the base **130** to avoid loss of the slip cover **280**.

Advantageously, in some embodiments, the slip cover **280** can be removed extremely rapidly, allowing for easy and rapid conversion from the collapsed to deployed configuration. The process can be reversed to switch from deployed to collapsed configuration by pulling the slip cover **280** over the antenna elements **110**, causing the antenna elements **110** to collapse against the mast and form the LOS configuration shown in FIG. **4**.

IV. Detailed Example Antenna Components

FIG. **8** illustrates an embodiment of a support structure **300** that can be included in an antenna, such as any of the antennas **100**, **200** described above. Like the support structure described above with respect to FIG. **1**, the support structure **300** includes an end cap **302**, a mast **320**, and a base **330**. Additional aspects of the support structure **300** are illustrated in order to detail example operation of the antenna **100**, **200**. More detailed embodiments of the base **330** are described below with respect to FIGS. **27** and **28**.

For example, the mast **320** (which can be formed as a tube or the like) includes a sliding rod **322** that can slide up and down within the mast **320**. A portion of the sliding rod **322** is illustrated in phantom to depict its position inside the mast **320**. The sliding rod **322** is connected to the end cap **302**, which as shown in FIGS. **1** through **3**, can be pivotably attached to the antenna elements **110**. Thus, as the end cap **302** moves up, the antenna elements collapse against the mast **320**, and as the end cap **302** moves down, the antenna

elements **110** expand into quadrifilar shape. The sliding rod **322** can facilitate the compression and expansion of the spring-loaded antenna elements **110** by sliding and thereby allowing the mast **320** to change size while maintaining rigid or semi-rigid support for the antenna elements **110**.

Various example components are also illustrated in the base **330**, including an antenna mode (e.g., internal) switch **332**, a LOS tuning circuit **334**, and a SATCOM tuning circuit **336**. The antenna mode switch **332** can be an electromechanical switch that selects between the LOS tuning circuit **334** and the SATCOM tuning circuit **336** for antenna tuning. In one embodiment, the antenna mode switch **332** is actuated mechanically by a tip **324** of the sliding rod **322** coming into contact with the antenna mode switch **332**. In one embodiment, as the antenna elements **110** expand into the quadrifilar shape, the tip **324** of the sliding rod **322** moves toward the base **330** and actuates the antenna mode switch **332**, causing the antenna mode switch **332** to select the SATCOM tuning circuit **336** to properly tune the antenna in SATCOM mode. If the antenna elements **110** are then collapsed toward the mast **320**, the tip **324** of the sliding rod **322** is pulled away from the antenna mode switch **332**, causing the antenna mode switch **332** to select the LOS tuning circuit **334** to properly tune the antenna in LOS mode.

In another embodiment, the antenna mode switch **332** is actuated by the soldier using a mechanical switch (e.g., a slide switch), which may be attached to the base **130**. In response to a soldier sliding the antenna mode switch **332** to a first position, the SATCOM tuning circuit **336** can be selected to properly tune the quadrifilar antenna in SATCOM mode. In response to sliding the antenna mode switch **332** to a second position, the antenna mode switch **332** selects the LOS tuning circuit **334** to properly tune the antenna in LOS mode. A drive circuit may also be included in either tuning circuit.

FIG. **9** illustrates a close-up view of an embodiment of the pivot elements **150** (see FIGS. **1-3** above). The pivot elements **150** shown connect an embodiment of the antenna elements **110** mechanically and electrically to the base **130**. An alternative embodiment of the antenna elements **110** that does not have pivot elements **150** is described below with respect to FIG. **23**.

The pivot elements **150** can be hinged or otherwise flexural members having an antenna element receptacle **152** and a base connection member **154**. A hinge pin **157** or the like connects the base connection member **154** with a corresponding antenna element receptacle **152**. The antenna element receptacle **152** can hold the antenna elements **110** in place with a friction fit, an adhesive, a set screw, combinations of the same, or the like. The antenna element receptacles **152** and base connection members **154** of the pivot elements **150** can be made of metal, allowing current to pass from the circuitry in the base **130** to the antenna elements **110**. In some embodiments, a small gap may exist between the antenna element receptacles **152**, the base connection members **154**, and the hinge pin **157**. Regardless, capacitive coupling between the various components **152**, **154**, **157** can allow RF signals to pass between the antenna elements **110** and circuitry in the base **130**. The base connection members **154** can be electrically connected to the circuitry in the base **130** in a variety of ways, such as by solder joints, screws connected to the members **154** and circuitry, combinations of the same, or the like. In one embodiment, the pivot elements **150** are anodized black or camouflage for concealment purposes, except that the pin **157** and holes in the elements **150** are not anodized to allow current to pass through.

The pivot elements **150** that connect the antenna elements **110** to the end cap **102** are not shown in detail but can have the same or a similar structure as the pivot elements **150**. However, the end cap **102** can include electrical connections (e.g., on a circuit board or through wiring) between antenna elements **110**. In one embodiment, opposing antenna elements connect to each other. For example, referring to FIG. **2**, pairs of antenna elements **110** connected to opposing pivot elements **150a**, **150b** can be connected in (or about) the end cap **102**. Likewise, pairs of antenna elements **110** connected to opposing pivot elements **150c**, **150d** can be connected in (or about) the end cap **102**. Each opposing pair of antenna elements **110** can therefore form a loop in the SATCOM expanded configuration.

FIG. **14** illustrates an embodiment of flexure elements **1452**, which can be used in place of the pivot elements **150** described above. While the flexure elements **1452** are shown connecting the antenna elements **110** to the base **130**, similar flexure elements (or variations thereof) can also be used to connect the antenna elements **110** to the end cap **102**. The flexure elements **1452** can advantageously flex by virtue of a leaf spring **1456** in each element **1452**, thereby allowing the antenna elements **110** to move from one configuration to another.

As shown, the flexure elements **1452** can include element receptacles **1454**, leaf springs **1456**, and mounting members **1460**. Each element receptacle **1454** attaches an antenna element **110** to a leaf spring **1456**. The element receptacle **1454** is attached to the leaf spring **1456** by fasteners **1466** via holes in the receptacle **1454** and leaf spring **1456**. Any suitable fastener or fasteners can be used, such as screws, bolts, pins, rivets, or the like. The leaf spring **1456** is in turn fastened between two portions **1462**, **1464** of the mounting members **1460** by fasteners **1472**, which can be any suitable fastener as described above. Each of the element receptacles **1454**, leaf springs **1456**, and mounting members **1460** may be made of metal so as to be conductive. Like the pivot elements **150**, any gaps in the flexure elements **1452** can produce capacitive coupling, which can allow RF signals to pass to and from the antenna elements **110**. In one embodiment, the flexure elements **1452** are anodized for concealment purposes, except that at least a portion of the leaf spring **1456** and holes in the elements **1452** are not anodized to allow current to pass through.

V. Example SATCOM Radiation Patterns

FIGS. **15** through **22** illustrate plots **1500-2200** of example electromagnetic radiation patterns **1510-2210** for the CP/SATCOM mode of the dual-polarized antenna. The example patterns **1510-2210** are shown for different transmit/receive frequencies. As shown, the patterns **1510-2210** are substantially omnidirectional with radiation predominantly in elevation angles (0 to 90 deg), while the patterns **1510-2210** indicate substantially attenuated radiation in the reverse direction (90 to 180 deg). In one embodiment, these substantially omnidirectional patterns allow the antenna to communicate in a vertical orientation with almost any satellite, without having to point the antenna at the satellite. Thus, a soldier or other user can simply mount the antenna vertically on his or her person or other equipment to achieve satellite communication. Users therefore do not need to know where satellites are positioned to communicate with them.

Advantageously, this omnidirectional or substantially omnidirectional upper hemispherical pattern is achieved in certain embodiments because the antenna elements are

twisted in the opposite orientation than the elements are driven electrically. For example, the antenna elements can be twisted with a left-hand orientation and be driven with right-hand circularly-polarized (RHCP) radiation. Alternatively, the antenna can be twisted with a right-hand orientation and driven with LHCP radiation to achieve the same or similar radiation patterns.

In some embodiments, driving the antenna in the expanded quadrifilar mode in the same polarization as the direction of twist (e.g., RHCP and right-hand twist) can cause the antenna to emit a narrow, high gain beam off the top of and along the axis of the antenna. In contrast, driving the antenna with the opposite polarization as the direction of twist can provide a wider, lower gain (e.g., omnidirectional or substantially omnidirectional) pattern as described above.

The antenna driving circuitry can switch between polarizations while the antenna is deployed in SATCOM mode to enable a soldier to communicate in a LOS mode without collapsing the antenna (e.g., to avoid detection by avoiding movement or sound). LOS performance in the expanded mode of the antenna may or may not be degraded relative to the collapsed LOS mode of the antenna. A switch in the base **130** may be provided for making the change from SATCOM to LOS mode. In another embodiment, the polarization need not be changed when communicating in SATCOM and LOS modes while the antenna is deployed, although performance may be degraded.

VI. Soldier Mounting and Tripod Base

There are many ways that the antenna can be used by soldiers or other users, one of which is illustrated in FIG. **10** (other options are described below with respect to FIGS. **24** and **25**). In FIG. **10**, an embodiment of the antenna, namely the antenna **400**, is connected to a vest **404** of a soldier **402**. An attachment mechanism **410** can be connected to a support tube attached to fabric loops sewn on the back of the vest **404**, slipped into a pocket of the vest **404**, or otherwise attached to the vest **404**. This attachment mechanism **410**, described in greater detail below, can include a pivot that allows the antenna **400** to pivot downwards (e.g., toward the soldier's **402** chest or back) to move the antenna **400** out of the way of trees, other equipment, etc. The antenna **400** can still work in this position, but may also be pivoted upwards in the vertical or substantially vertical position shown for better reception in some embodiments.

For illustrative purposes, the antenna **400** is shown in the collapsed LOS configuration. As the antenna **400** is vertical with respect to the soldier **402** (and the ground), the antenna **400** is vertically polarized. When the antenna **400** is in the deployed SATCOM configuration, the soldier **402** can pivot the antenna **400** in an orientation to generally point in the direction of low-earth orbit (LEO) or geosynchronous orbiting (GEO) satellites.

FIG. **11** illustrates a more detailed embodiment of the attachment mechanism **410** of FIG. **10**, namely an example attachment mechanism **510**. This attachment mechanism **510** includes a pivot member **512** and a base attachment plate **514**. The base attachment plate **514** can attach to the bottom of the base (e.g., **130**) of any of the antennas described herein. The tripod **516** provides a stable support platform for the antenna to be placed on the ground or other surface, and the pivot member **512** allows the antenna to be pointed in substantially any direction.

The tripod **516** is collapsible, as shown for example in FIG. **12**. Legs **518** of the tripod are collapsed against a support structure **522** of the tripod **516**. In this configuration,

the collapsed tripod **516** can be inserted into a vest pocket or backpack or strapped onto another article of clothing, vehicle, building, etc. In addition, the collapsed tripod **516** can be held in a soldier's hand. To place the tripod **516** in context, an example connection of the tripod **516** to a base **530** (corresponding to the base **130**) of an antenna is shown in FIG. **13**. For ease of illustration, the remainder of the antenna is not shown, although it may be attached to the base **530**. The base **530** is also illustrated with a slip cover **532** covering the base. The base attachment plate **514** attaches the attachment mechanism **510** to the base **530**. A hole in the base attachment plate **514** (see FIG. **11**) allows an electrical connector **570** to pass through for connection to a radio. The tripod and/or base can act as a handle of the antenna.

VII. Example Hingeless Antenna and Hard Case

FIGS. **23A** through **23C** depict another embodiment of a dual-polarized antenna **2300**. The antenna **2300** includes many of the features of the antenna **100** described above, such as an end cap **2302**, antenna elements **2310**, a base **2330**, and an electrical connector **2370**. Each of these components can have any of the features described above (or below). A difference between the antenna **2300** and the antenna **100** is that the antenna **2300** does not have pivot elements **150** or flexure elements **1452**. Instead, the antenna elements **2310** are shaped to create bends **2350** in the elements **2310** near the base **2330** and end cap **2302**, which facilitate the ends of the elements **2310** being inserted directly into the base **2330** and end cap **2302**. The bends **2350** in the elements **2310** can be more rigid and stable than the pivot and flexure elements described above, with fewer points of failure in some embodiments.

FIG. **24** depicts an embodiment of a case or tube **2480** configured to cover the dual-polarized antenna, mounted on a soldier in a collapsed LOS mode. Either the antenna **100** or **2300** can be disposed in the tube **2480**. For convenience, the remainder of this description will refer to the antenna **2300**, although it should be understood that the antenna **100** may be used interchangeably.

In the depicted embodiment, the tube **2480** is a hard, cylindrical tube, as opposed to the soft, fabric cylindrical sleeve tube described above. The tube **2480** can be made of plastic, nylon, or any other suitable radiation-permeable material. The antenna **2300** is mostly enclosed by the tube **2480**, although the end cap **2302** of the antenna **2300** sticks out above the top of the tube **2480**. The antenna **2300** is therefore collapsed inside the tube **2480** and may operate in LOS mode in this configuration. The end cap **2302** can be grabbed and pulled by the user to pull the antenna elements at least partially out of a top opening of the tube to cause the antenna elements to expand for SATCOM operation, as shown in FIG. **25**. A hook or other handle can be connected to the end cap **2302** in an embodiment for easy pulling by a soldier.

With continued reference to FIGS. **24** and **25**, a cable **2493** attached to the electrical connector **2370** at the base **2330** of the antenna **2300** protrudes through a bottom opening of the tube **2480**. The user of FIG. **25** can pull on the cable **2493** to retract the antenna elements **2310** into the tube **2480** to achieve the LOS configuration of FIG. **24**. A motorized antenna retraction and deployment mechanism can also be included in the tube **2480** in some embodiments.

The tube **2480** is connected to a backpack **2404** of the user via clamps **2482** that clamp both around the tube **2480** and around a metal tubular frame of the backpack **2404** (not shown). Wing nuts **2483** allow the clamps **2482** to be opened

so that the tube 2480 may be removed from the backpack. The tube 2480 could, in other embodiments, be connected directly to an article of clothing of the user, to a vehicle, or to any structure.

FIG. 26 depicts another embodiment of a tube 2680 for the dual-polarized antenna. In this embodiment, the tube 2680 is drawn schematically and includes a portion of the antenna 2300 disposed therein, namely a base 2630 of the antenna. The base 2630 is drawn in phantom to indicate its presence inside of the tube 2680 and would normally not be seen from the current view when inside the tube 2680. An electrical connector 2670 is shown at the bottom of the base 2630.

The tube 2680 allows the base 2630 to move slidably up and down within the tube to effectuate the deploying and collapsing of the antenna elements, respectively. In some embodiments, it is desirable to not allow the antenna 2300 to come completely out of the tube 2680. Accordingly, a lip 2681 is provided at the top of the tube 2680 that engages with and prevents a top surface 2631 of the base 2630 from protruding outside of the tube 2680. Although the base 2680 cannot be removed in this depiction, antenna elements connected to the base 2630 (not shown) can protrude through a hole 2682 defined by the lip 2681 of the tube 2680. Similarly, the bottom surface of the base 2630 is blocked from protruding at the bottom of the tube 2680 by a lip 2683 that defines a hole 2685 having a smaller diameter than the diameter of the tube 2680.

In other embodiments, the inside surface of the top and/or bottom of the tube 2680 can include one or more detents (or a detent ring) that prevents the base 2630 from protruding outside of the tube unless sufficient force is supplied to move the base 2630 over the detent. A leaf spring may be used in place of a detent to obtain a similar effect.

VIII. Example Antenna Base Features

FIG. 27 depicts an embodiment of an interior of a base 2730 of the dual-polarized antenna. As mentioned above with respect to FIG. 8, the sliding rod 322 within the mast 120 of the antenna can actuate an antenna mode switch 332 in the base of the antenna. In the base 2730 of FIG. 27, the actuation of a sliding rod 2722 within a mast 2720 also facilitates switching antenna modes.

In FIG. 27, the sliding rod 2722 is connected to a sliding cylinder 2723 that moves slidably up and down within the base 2730 (as indicated by arrows within the base 2730). The sliding cylinder 2723 is also in communication with an antenna matching circuit 2734. The sliding action of the sliding cylinder 2723 can actuate the antenna matching circuit 2734 to switch between SATCOM matching and LOS matching. A more detailed mechanical mechanism for performing this switching is described below with respect to FIG. 28.

The sliding action of the cylinder 2723 also facilitates shorting the antenna elements 2710 together to enter LOS mode. As described above, the antenna elements 2710 can be driven separately (e.g., at different phases) in SATCOM mode while being driven together as a lumped element or single conductor in LOS mode. The cylinder 2723 can short all (or some of) the elements 2710 together in the LOS mode. When in the LOS mode, the sliding rod 2722 of the mast 2720 is pulled upwards to cause the antenna elements 2710 to collapse against the mast 2720. This upward pulling of the sliding rod 2722 also pulls the sliding cylinder 2723

upward within an annular void 2735 of the base 2730 until the sliding cylinder 2723 is in contact with the top of the interior of the base 2730.

A conductive layer 2726 of material is disposed at the top of the sliding cylinder 2723. This conductive layer 2726 may be an annular film or layer. When pulled against the interior top of the base 2730 by action of the sliding rod 2722 and cylinder 2723, this conductive layer 2726 can come into contact with conductive pads 2739 disposed on the bottom of a circuit board 2737 to which the antenna elements 2710 are affixed. The conductive layer 2726 can therefore short the conductive pads 2739 together so that the antenna matching circuit 2734 can drive the antenna elements 2710 as a single, LOS conductor. A compressive layer 2724 made of foam or other compressible material disposed underneath the conductive layer 2726 and on top of the sliding cylinder 2723 can facilitate compression of the conductive layer 2726 against the conductive pads 2739.

Sliding the sliding rod 2722 downwards within the mast 2720 can push the cylinder 2723 and therefore conductive layer 2726 away from the conductive pads 2739, thereby allowing the antenna elements 2710 to be driven separately in SATCOM mode.

FIGS. 28A, 28B, and 28C depict a more detailed embodiment of an interior of a base 2830 of the dual-polarized antenna. In FIG. 28A, the exterior wall of the base 2830 is shown, but this exterior wall is absent in FIGS. 28B and 28C. This embodiment depicts the base 2830 connected to the flexure elements 2850, which in turn may attach to antenna elements (not shown). However, pivotal elements or bent antenna elements (as in FIG. 23) may be used in place of the flexure elements 2850 in other embodiments.

Like the base 2730, the base 2830 includes a sliding cylinder 2823 that can move slidably up and down to selectively come into engagement with a printed circuit board 2837. The top surface 2826 of the sliding cylinder 2823 can include a conductive material that shorts out pads (not shown) on the bottom of the circuit board 2837 when the cylinder 2823 is engaged with the circuit board 2837. Likewise, the top surface 2826 of the sliding cylinder 2823 can include the compressive layer 2724 of FIG. 27. The sliding rod, although not shown, can be connected to the sliding cylinder 2823 to effectuate the up and down movement of the cylinder 2823.

Referring to FIG. 28B, the sliding cylinder 2823 is connected to a rack 2856 and pinion 2894 via an armature 2895 (connected to the pinion). As the cylinder 2823 slides up and down within the base 2830, the pinion 2894 moves along the rack 2856 due to the pinion 2894 being connected to the armature 2895. The rack 2856 and pinion 2894 provides friction resistance to the movement of the cylinder 2823 in some embodiments, thereby causing the cylinder 2823 to be firmly engaged with the circuit board 2837. In one embodiment, sliding the sliding cylinder 2823 upwards causes the armature 2895 to move to the right (with respect to the FIGURE) of the center of the pinion 2894. As a result, shock and vibration cannot easily reverse the position of the pinion 2894 and cause the cylinder 2823 to move downwards away from the circuit board 2837. Downward pressure on the armature 2895 from shock or vibration may cause the armature 2895 to push down on the pinion 2894, such that the pinion 2894 would attempt to rotate upwards (toward the sliding cylinder 2823) along the rack 2856. However, this movement of the pinion 2894 would serve to tighten the sliding cylinder 2823 against the circuit board 2837. The connection between the conductive surface atop the cylinder 2823 and the pads of the circuit board 2837 can

therefore remain close or tight despite some jostling or vibration of the antenna. A user can actuate the sliding arm **2890**, which can be connected to the rack **2856**, to move the rack **2856** upwards, causing the pinion **2894** to roll in the opposite direction to movement of the rack **2856**. This movement of the pinion **2894** can move the armature **2895** over to the left of center of the pinion **2894**, effectively unlocking the cylinder **2823** to slide downwards and disengage from the circuit board **2837**.

A SATCOM switching circuit **2836** is shown on one side of the base **2830** in FIG. **28A**, and an LOS switching circuit **2834** is shown on the other side of the base **2830** in FIG. **28B**. FIG. **28C** shows an end view of the base **2830**, rotated 90 degrees from FIGS. **28A** and **28B** so that the SATCOM switching circuit **2836** is shown on the left while the LOS switching circuit **2834** is shown on the right. A microswitch **2891** is in electrical communication with both switching circuits **2834**, **2836** and can be automatically actuated by the movement of the sliding cylinder **2823** to select between use of the different switching circuits **2836**, **2834**. The microswitch **2891** includes an arm **2893** that is coupled with a sliding arm **2890** that is coupled with the rack **2856** and pinion **2894**. When the pinion **2894** moves upward with the cylinder **2823** (into LOS mode), the arm **2890** moves upward as shown in FIG. **23B**, causing the arm **2893** of the microswitch **2891** to be pulled away from the microswitch **2891** (deactivated), selecting the LOS switching circuit **2834**. Conversely, when the pinion **2894** moves downward with the cylinder **2823** (into SATCOM mode), the arm **2890** moves downward, and a bend in the arm **2890** depresses the arm **2893** of the microswitch **2891**, selecting the SATCOM switching circuit **2836**. The arm **2890** can also be manually actuated, as shown in FIG. **28A**, by being pressed or pulled by the operator/soldier.

In some embodiments, the rack **2856** and/or pinion **2894** can be exposed outside of the base **2830** (e.g., through a window in the base **2830**) for thumb-slide manual activation by a user. In yet another embodiment, the actuation arm **2890** can be connected to a solenoid in the base **2830** that is in turn in electrical communication with a radio connected to the base **2830** so that the radio can send a switching signal to actuate the solenoid when changing communications modes. A camera type cable release can also be attached to the base **2830** so that a soldier can switch from his chest area or gun support hand area, rather than by having to touch the base **2830**.

IX. Other Embodiments and Features

In addition to the embodiments shown, many other configurations of the dual-polarized antenna are possible. For instance, in some embodiments one or more spacers (such as plastic or nylon spacers) can be fastened to the pairs of antenna elements **110** to provide rigidity to the antenna elements **110**. An antenna element covering may also be provided to cover the antenna elements **110** in both the LOS and SATCOM positions. This covering can be a cloth covering or the like that can fit under the slip cover, and which may reduce potential snagging of the antenna elements on bushes, trees, or other equipment. The antenna element covering can be transparent, translucent, black, camouflage, have netting, or the like to reduce visibility of the antenna.

Although a slip cover **280** is shown as the mechanism for converting from collapsed to deployed configuration and vice versa, a different mechanism may be used to accomplish this conversion in other embodiments. For instance,

referring to FIG. **8**, a locking mechanism can be included in the support structure **300** to lock the sliding rod **322** in the mast **320** at an extended position, which can cause the antenna elements to be held collapsed against the mast **120** without a cover. An example of a locking mechanism can be a spring-loaded pin or the like that locks into place when the sliding rod **322** reaches a certain height with respect to the mast **120**. The locking mechanism can be actuated to an unlocked position. The spring-loaded antenna elements can then pull the sliding rod toward the base **130** automatically, causing the antenna to convert to the SATCOM configuration. The locking mechanism can be electronically actuated in some embodiments.

In still other embodiments, the antenna elements need not be pre-shaped but instead can be twisted into the proper shape either manually or via a mechanism in the support structure. This mechanism may be a groove, set of grooves, or the like that the sliding rod twists into as the sliding rod is pushed into the mast (e.g., by a user pushing on the end cap). The sliding rod may have screw grooves to match the grooves in the mast. As the sliding rod twists into the grooves, the end cap can twist and thereby twist the antenna elements. The sliding rod can lock into place via a locking mechanism in the mast, such as is described above, to lock the antenna in the quadrifilar SATCOM configuration. Other configurations are also possible.

Moreover, any cover or mechanism can be used that allows the antenna elements to collapse, instead of the soft and hard covers shown. For instance, the cover can be a hard plastic or metal telescoping shell, a clamshell, or a hook-and-loop fastener (e.g., Velcro™) that wraps around the antenna elements, or any combination of the same.

The base may include various types of electronic circuitry. As described above, some of this circuitry can optionally include passive (or active) analog matching networks. Matching circuitry can be omitted from the base, however, if a separate antenna tuner is connected to the antenna or is provided in an attached radio. Functionally, the base can include any analog or digital circuitry, including optionally one or more microprocessors for performing various functions. Further, the base can include electromechanical components, such as motors, relays, or other actuators or switches. Several examples of base features will now be described, although it should be understood that the described examples are not exhaustive. Furthermore, the circuitry described herein can be attached to another component of the antenna other than the base in some embodiments.

In one embodiment, the base includes a diplexer that can facilitate half or full-duplex communications with a remote device. This diplexer can facilitate radio communications with the Mobile User Objective System (MUOS) of GEO satellites, among other systems. In another embodiment, the base includes a transmit/receive sensing module. This electronic module can detect when a signal is sent from a radio to the antenna for transmit and automatically select a matching network efficient for transmission. At other times when the antenna is not transmitting, the antenna can switch to or default to a matching network that is more efficient for receiving. The matching networks can be selected to match for different frequencies, for example. In yet another embodiment, the base includes an automatic antenna tuning circuit or module that detects a frequency of transmission and automatically tunes the antenna to match that frequency. Such a tuning module can advantageously enable better antenna matching in frequency hopping and spread-spectrum communications.

Another feature that can be included in the antenna in certain embodiments is an automatic mode change module. The mode change module can include an electric motor, one or more actuators, and associated circuitry that can automatically change the antenna from SATCOM configuration to LOS configuration and vice versa. In one embodiment, the mode change module can automatically change the antenna from one configuration to another based on a frequency dialed in by a user on a radio, or by a frequency of transmission detected, or by some option selected by a user from a user interface in the base or radio. This feature can be especially useful if the antenna is vehicle-mounted or building-mounted. The base can also include a full radio in some embodiments, which may optionally have a screen or other user interface. Thus, the antenna can be a self-contained communications system in some embodiments.

It should be noted that in some embodiments, when the antenna is in an expanded configuration, the elements can be driven together to achieve LOS mode and driven separately to achieve SATCOM mode. With the expanded configuration of the antenna able to radiate in either LOS or SATCOM mode, as described above, the antenna enables a soldier to use LOS and SATCOM communications without having to alternately collapse and expand the antenna. Moreover, in some embodiments, the sleeve or other collapsing mechanism can be omitted entirely. Further, the antenna can be designed with a fixed mast such that the antenna is fixed in the expanded configuration.

The electronics (such as antenna matching and/or drive circuitry) described herein as residing in the base may be disposed in the end cap or mast in some embodiments, instead of the base. Alternatively, portions of the electronics can be disposed in any combination of the end cap, mast, and base. In some embodiments, the base may be shortened substantially or substantially omitted entirely (e.g., a very thin structure for holding the antenna elements may be used in place of the base if the electronics in the base are instead in the mast or end cap).

X. Example Process of Fabricating Superelastic Wire Elements

As described above, the antenna elements may be made of memory metal or superelastic wire in some embodiments.

Metal alloys that have the shape memory effect include binary metals and ternary metals, such as some of the example metals described herein. The most common shape memory effect alloy utilized is the binary metal of nickel and titanium in close to equal amounts. The basis of the shape memory effect is that these alloys undergo a change in their crystal structure as they are cooled and heated through a temperature called the transformation temperature TTR. Extreme elasticity or superelasticity occurs at temperatures above the transformation temperature because the crystal structural transformation can be caused by stress. As the deformation occurs, a structural transformation happens, but then reverses as the stress is reduced and the structural transformation reverses. The type of transformation is known as a thermoelastic martensitic transformation and changes the material from the higher temperature form called austenite.

In other words, superelasticity can occur when shear stress is applied to an austenitic alloy to cause it to transform to deformed martensite in a way that relieves the applied stress. When the stress is relieved, the material reverts back to austenite. This is repeatable because the deformation in the martensite mode is non-damaging to the crystal struc-

ture. In normal metal alloys, deformation by atomic slip has no memory and does not reverse itself and results in work hardening.

For a given alloy, with a specific heat treating process, under specific stress conditions, this transformation temperature (TTR) occurs at a repeatable temperature and superelasticity occurs over a repeatable temperature range. The temperature that superelasticity occurs and the range of temperature that superelasticity is exhibited over can depend on the composition of the alloy, how it is worked, and how it is heat treated during shape forming.

An ingot of the metal alloy material with a very low TTR can be made by a number of metal foundries. From this type of ingot, the antenna element wire can be drawn, which can result in typically 40% cold worked wire material. This cold worked wire material may show very poor or non-existent shape memory or superelasticity until it is heat-treated. This wire material can then be placed in a shaping form, such as a spiral, that holds the wire in the desired shape as the temperature is increased from room temperature to between about 300 degrees C. to about 600 degrees C. for between about 1 minute to about 10 minutes. The formed wire can be quenched rapidly back to room temperature using cool water or cool air. The result can be a shape-formed wire that has superelastic properties.

XI. Terminology

Many other variations than those described herein will be apparent from this disclosure. For example, depending on the embodiment, certain acts, events, or functions of any of the processes described herein can be performed in a different sequence, can be added, merged, or left out all together (e.g., not all described acts or events are necessary).

Certain illustrative logical blocks and modules described in connection with the embodiments disclosed herein can be implemented or performed by analog circuitry or a digital machine, such as a general purpose processor, a digital signal processor (DSP), an application specific integrated circuit (ASIC), a field programmable gate array (FPGA) or other programmable logic device, discrete gate or transistor logic, discrete hardware components, or any combination thereof designed to perform the functions described herein. A general purpose processor can be a microprocessor, but in the alternative, the processor can be a controller, microcontroller, or state machine, combinations of the same, or the like. A processor can also be implemented as a combination of computing devices, e.g., a combination of a DSP and a microprocessor, a plurality of microprocessors, one or more microprocessors in conjunction with a DSP core, or any other such configuration.

The steps of a method, process, or algorithm described in connection with the embodiments disclosed herein can be embodied directly in hardware, in a software module executed by a processor, or in a combination of the two. A software module can reside in memory or any other form of non-transitory computer-readable storage medium or media. An exemplary storage medium can be coupled to the processor such that the processor can read information from, and write information to, the storage medium. In the alternative, the storage medium can be integral to the processor.

Conditional language used herein, such as, among others, "can," "might," "may," "e.g.," and the like, unless specifically stated otherwise, or otherwise understood within the context as used, is generally intended to convey that certain embodiments include, while other embodiments do not include, certain features, elements and/or states. Thus, such

19

conditional language is not generally intended to imply that features, elements and/or states are in any way required for one or more embodiments or that one or more embodiments necessarily include logic for deciding, with or without author input or prompting, whether these features, elements and/or states are included or are to be performed in any particular embodiment. The terms “comprising,” “including,” “having,” and the like are synonymous and are used inclusively, in an open-ended fashion, and do not exclude additional elements, features, acts, operations, and so forth. Also, the term “or” is used in its inclusive sense (and not in its exclusive sense) so that when used, for example, to connect a list of elements, the term “or” means one, some, or all of the elements in the list.

While the above detailed description has shown, described, and pointed out novel features as applied to various embodiments, it will be understood that various omissions, substitutions, and changes in the form and details of the devices or algorithms illustrated can be made without departing from the spirit of the disclosure. As will be recognized, certain embodiments of the inventions described herein can be embodied within a form that does not provide all of the features and benefits set forth herein, as some features can be used or practiced separately from others.

What is claimed is:

1. An antenna comprising:
 - a support structure comprising:
 - a mast comprising a top end and a bottom end,
 - an end cap attached to the top end of the mast, and
 - a base attached to the bottom end of the mast; and
 - an antenna element comprising a first end and a second end, the antenna element configured to expand from a collapsed first configuration to a deployed second configuration, the first end coupled to the end cap of the support structure in the first configuration and in the second configuration and the second end coupled to the base of the support structure in the first configuration and in the second configuration;
 - wherein in the first configuration the antenna element is collapsed toward the mast; and
 - wherein in the second configuration the antenna element is moved away from the mast.
2. The antenna of claim 1, further comprising a tube configured to cover the antenna element in the collapsed first configuration.
3. The antenna of claim 2, wherein the tube comprises one or more of a hard cover or a soft cover.
4. The antenna of claim 2, further comprising an attachment mechanism configured to affix the tube to a backpack.
5. The antenna of claim 1, wherein the antenna element comprises one of pre-shaped nickel titanium alloy memory metal or shapeable nickel titanium alloy memory metal.
6. The antenna of claim 1, wherein the antenna element comprises at least one of copper, iron, niobium, hafnium, cobalt, nickel-titanium cobalt, an alloy of superelastic memory metal, spring steel, beryllium-copper, or piano wire.
7. The antenna of claim 6, wherein the alloy of superelastic memory metal comprises at least one of AgCd, AuCd, CuAlNi, CuSn, CuZn, InTi, NiAl, FePt, MnCu, or FeMnSi.
8. The antenna of claim 1, wherein the antenna element and a second antenna element in the antenna are configured to expand to a substantially ellipsoid shape or spherical shape in the second configuration.

20

9. The antenna of claim 1, wherein the antenna element and a second antenna element in the antenna are configured to expand into a substantially quadrifilar helix configuration in the second configuration.

10. The antenna of claim 9, wherein the antenna element has an amount of twist between about 90 degrees to about 270 degrees.

11. The antenna of claim 1, wherein the antenna element comprises a pair of wires, each wire in the pair being driven together with the other wire in the pair.

12. The antenna of claim 11, wherein the pair of wires and another pair of wires associated with a second antenna element form a loop in the second configuration.

13. An antenna comprising:

- a support structure comprising:
 - a mast comprising a top and a bottom;
 - an end cap attached to the top of the mast; and
 - a base attached to the bottom of the mast, an electrical connector coupled to the bottom of the base configured to be in electrical communication with a radio; and

at least four antenna elements shaped in a twisted quadrifilar helix, the antenna elements in electrical communication with the electrical connector in the base;

wherein the sole mechanical connections of the at least four antenna elements with the support structure are at the base and at the end cap, such that the at least four antenna elements are spaced from the mast, and wherein each of the at least four antenna elements comprises a first end and a second end that permit each of the at least four antenna elements to collapse against the mast in a stowed configuration; and

wherein the at least four antenna elements are configured to radiate one or both of linearly-polarized radiation and circularly-polarized radiation.

14. The antenna of claim 13, wherein each first end is connected to the base and each second end is connected to the end cap, and wherein each first end is perpendicular to the base and wherein each second end is perpendicular to the end cap.

15. The antenna of claim 13, wherein the at least four antenna elements are configured to radiate linearly-polarized radiation and circularly-polarized radiation at separate times.

16. The antenna of claim 13, wherein each first end is connected to the end cap and each second end is connected to the base.

17. The antenna of claim 16, wherein each first end comprises a first bend and each second end comprises a second bend, the first and second bends configured to permit each of the at least four antenna elements to collapse toward the mast in the stowed configuration.

18. The antenna of claim 13, wherein the at least four antenna elements comprise memory metal.

19. The antenna of claim 13, wherein the at least four antenna elements comprise at least one of nitinol, copper, iron, niobium, hafnium, cobalt, nickel-titanium, nickel-titanium cobalt, an alloy of superelastic memory metal, spring steel, beryllium-copper, or piano wire.

20. The antenna of claim 13, wherein the base comprises a diplexer.

21. The antenna of claim 13, wherein the bottom of the base is coupled to a flexible attachment mechanism.

22. An antenna comprising:

- a support structure comprising:
 - a mast comprising a top end and a bottom end,
 - an end cap attached to the top end of the mast, and

21

a base attached to the bottom end of the mast; and
 an antenna element comprising a first end and a second
 end, the first end coupled to the end cap of the support
 structure and the second end coupled to the base of the
 support structure, the antenna element configured to
 expand from a collapsed first configuration to a
 deployed second configuration, wherein the antenna
 element comprises one of pre-shaped nickel titanium
 alloy memory metal or shapeable nickel titanium alloy
 memory metal;

wherein in the first configuration the antenna element is
 collapsed toward the mast; and

wherein in the second configuration the antenna element
 is moved away from the mast.

23. An antenna comprising:

a support structure comprising:

a mast comprising a top end and a bottom end,
 an end cap attached to the top end of the mast, and
 a base attached to the bottom end of the mast; and

an antenna element comprising a first end and a second
 end, the first end coupled to the end cap of the support
 structure and the second end coupled to the base of the
 support structure, the antenna element configured to
 expand from a collapsed first configuration to a
 deployed second configuration, wherein the antenna
 element comprises at least one of copper, iron, niobium,
 hafnium, cobalt, nickel-titanium cobalt, an alloy
 of superelastic memory metal, spring steel, beryllium-
 copper, or piano wire, and wherein the alloy of super-
 elastic memory metal comprises at least one of AgCd,
 AuCd, CuAlNi, CuSn, CuZn, InTi, NiAl, FePt, MnCu,
 or FeMnSi;

wherein in the first configuration the antenna element is
 collapsed toward the mast; and

wherein in the second configuration the antenna element
 is moved away from the mast.

24. An antenna comprising:

a support structure comprising:

a mast comprising a top end and a bottom end,
 an end cap attached to the top end of the mast, and
 a base attached to the bottom end of the mast; and

an antenna element comprising a first end and a second
 end, the first end coupled to the end cap of the support
 structure and the second end coupled to the base of the
 support structure, the antenna element configured to
 expand from a collapsed first configuration to a
 deployed second configuration, wherein the antenna
 element and a second antenna element in the antenna
 are configured to expand to a substantially ellipsoid
 shape or spherical shape in the second configuration;

wherein in the first configuration the antenna element is
 collapsed toward the mast; and

wherein in the second configuration the antenna element
 is moved away from the mast.

25. An antenna comprising:

a support structure comprising:

a mast comprising a top end and a bottom end,
 an end cap attached to the top end of the mast, and
 a base attached to the bottom end of the mast; and

an antenna element comprising a first end and a second
 end, the first end coupled to the end cap of the support
 structure and the second end coupled to the base of the
 support structure, the antenna element configured to
 expand from a collapsed first configuration to a
 deployed second configuration, wherein the antenna
 element and a second antenna element in the antenna

22

are configured to expand into a substantially quadrifilar
 helix configuration in the second configuration;

wherein in the first configuration the antenna element is
 collapsed toward the mast; and

wherein in the second configuration the antenna element
 is moved away from the mast.

26. The antenna of claim **25**, wherein the antenna element
 has an amount of twist between about 90 degrees to about
 270 degrees.

27. An antenna comprising:

a support structure comprising:

a mast comprising a top end and a bottom end,
 an end cap attached to the top end of the mast, and
 a base attached to the bottom end of the mast; and

an antenna element comprising a first end and a second
 end, the first end coupled to the end cap of the support
 structure and the second end coupled to the base of the
 support structure, the antenna element configured to
 expand from a collapsed first configuration to a
 deployed second configuration, wherein the antenna
 element comprises a pair of wires, each wire in the pair
 being driven together with the other wire in the pair;
 wherein in the first configuration the antenna element is
 collapsed toward the mast; and

wherein in the second configuration the antenna element
 is moved away from the mast.

28. The antenna of claim **27**, wherein the pair of wires and
 another pair of wires associated with a second antenna
 element form a loop in the second configuration.

29. An antenna comprising:

a support structure comprising:

a mast comprising a top and a bottom;
 an end cap attached to the top of the mast; and
 a base attached to the bottom of the mast, an electrical
 connector coupled to the bottom of the base config-
 ured to be in electrical communication with a radio;
 and

at least four antenna elements shaped in a twisted quadri-
 filar helix, the antenna elements in electrical commu-
 nication with the electrical connector in the base,
 wherein each of the at least four antenna elements
 comprises a first end and a second end, wherein the first
 end is connected to the end cap and the second end is
 connected to the base, and wherein the first end com-
 prises a first bend and the second end comprises a
 second bend, the first and second bends configured to
 permit the antenna to collapse against the mast in a
 stowed configuration;

wherein the sole mechanical connections of the at least
 four antenna elements with the support structure are at
 the base and at the end cap, such that the at least four
 antenna elements are spaced from the mast; and

wherein the at least four antenna elements are configured
 to radiate one or both of linearly-polarized radiation
 and circularly-polarized radiation.

30. An antenna comprising:

a support structure comprising:

a mast comprising a top and a bottom;
 an end cap attached to the top of the mast; and
 a base attached to the bottom of the mast, an electrical
 connector coupled to the bottom of the base config-
 ured to be in electrical communication with a radio;
 and

at least four antenna elements shaped in a twisted quadri-
 filar helix, the antenna elements in electrical commu-

nication with the electrical connector in the base,
wherein the at least four antenna elements comprise
memory metal;
wherein the sole mechanical connections of the at least
four antenna elements with the support structure are at 5
the base and at the end cap, such that the at least four
antenna elements are spaced from the mast; and
wherein the at least four antenna elements are configured
to radiate one or both of linearly-polarized radiation
and circularly-polarized radiation. 10

* * * * *