

A. LUNDGREN.

BOOT HOLDER.

APPLICATION FILED NOV. 14, 1910.

999,382.

Patented Aug. 1, 1911.

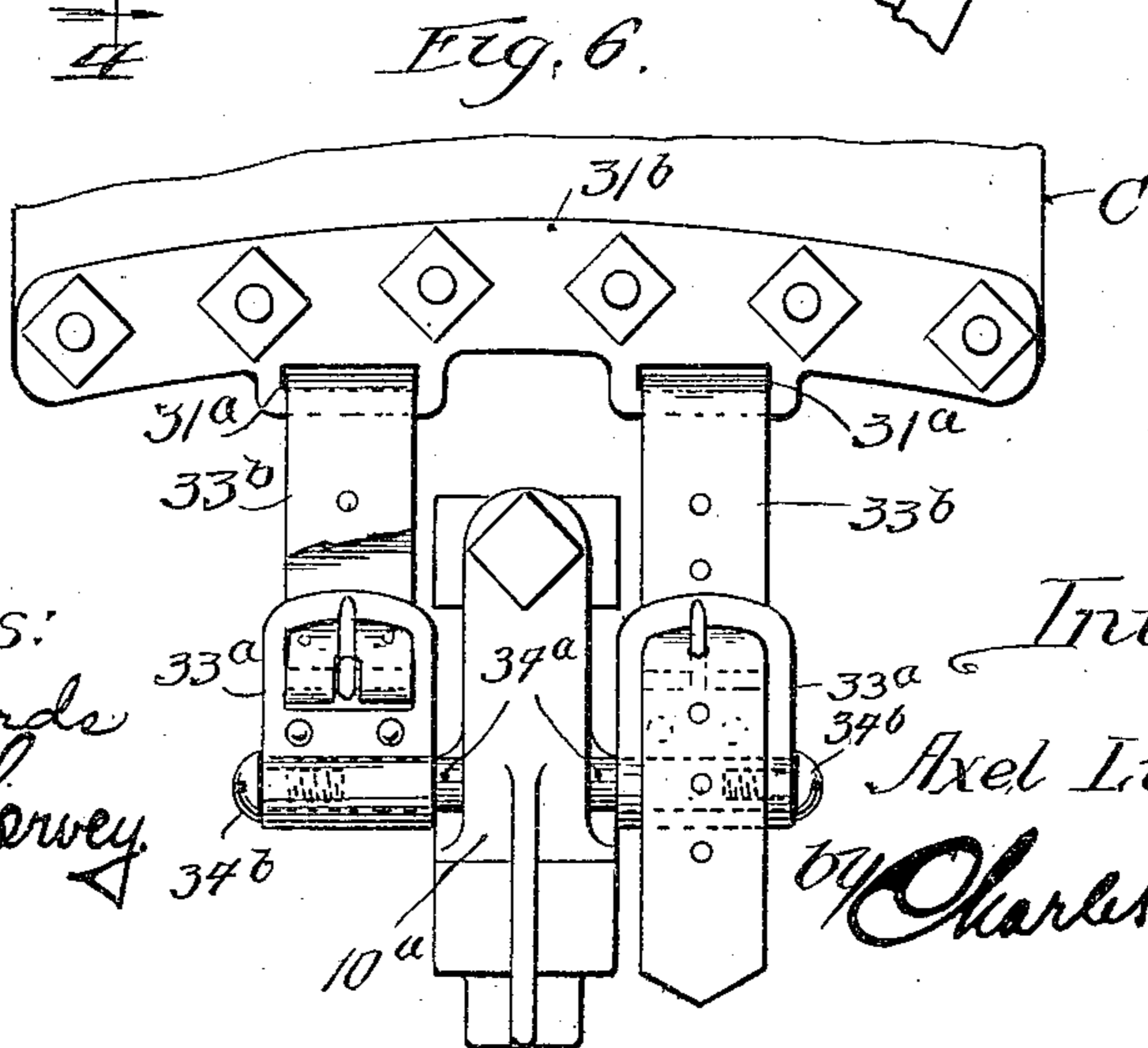
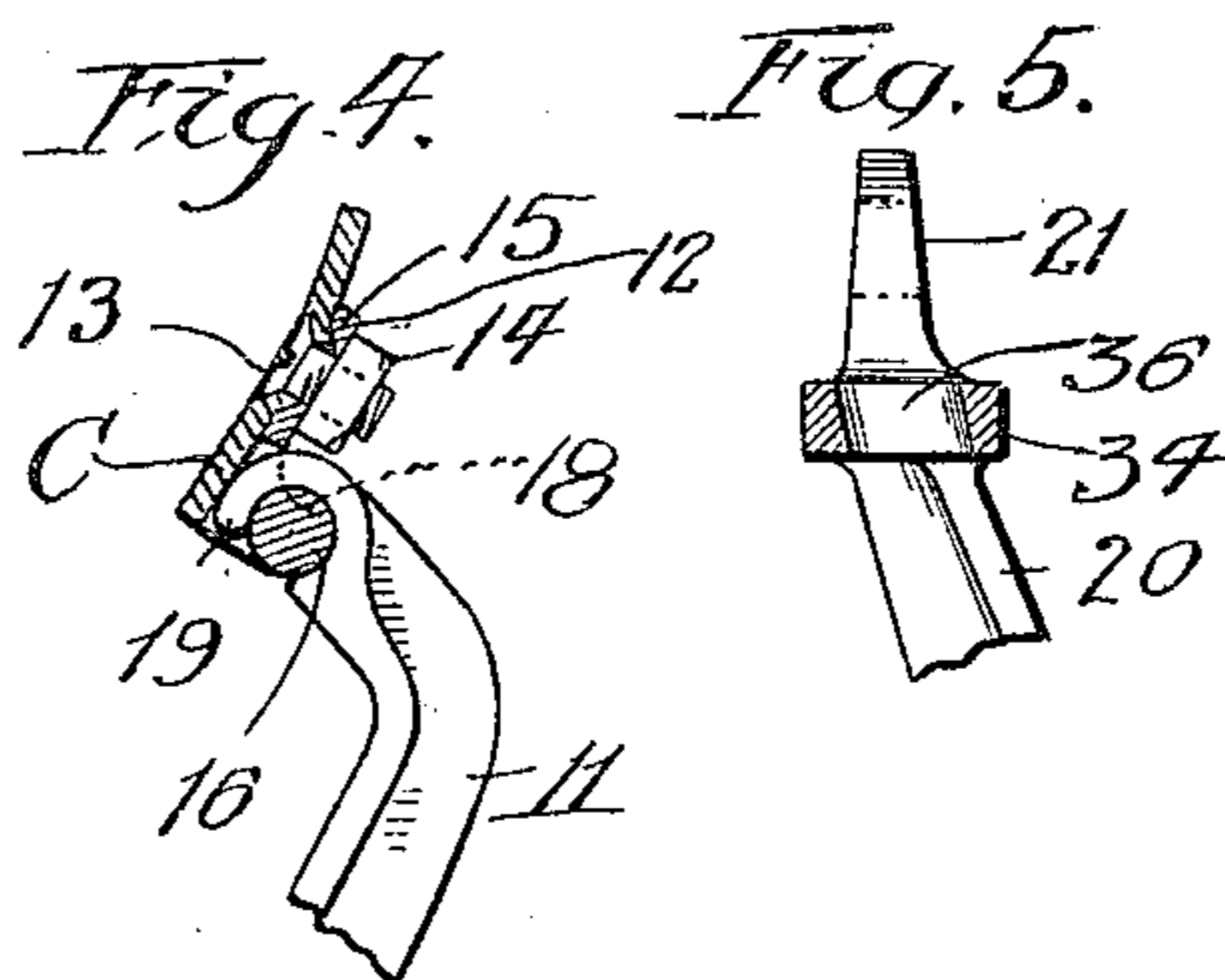
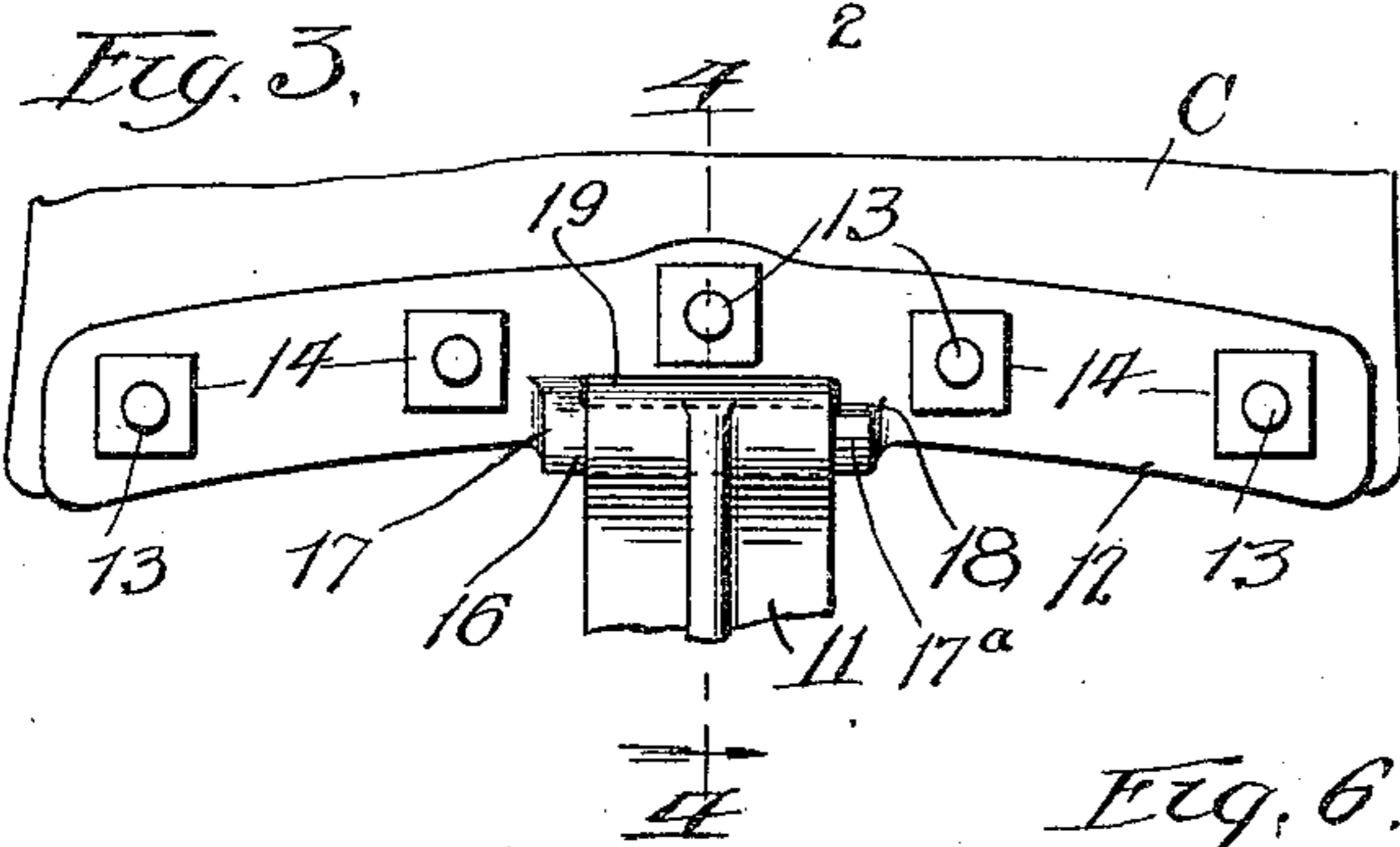
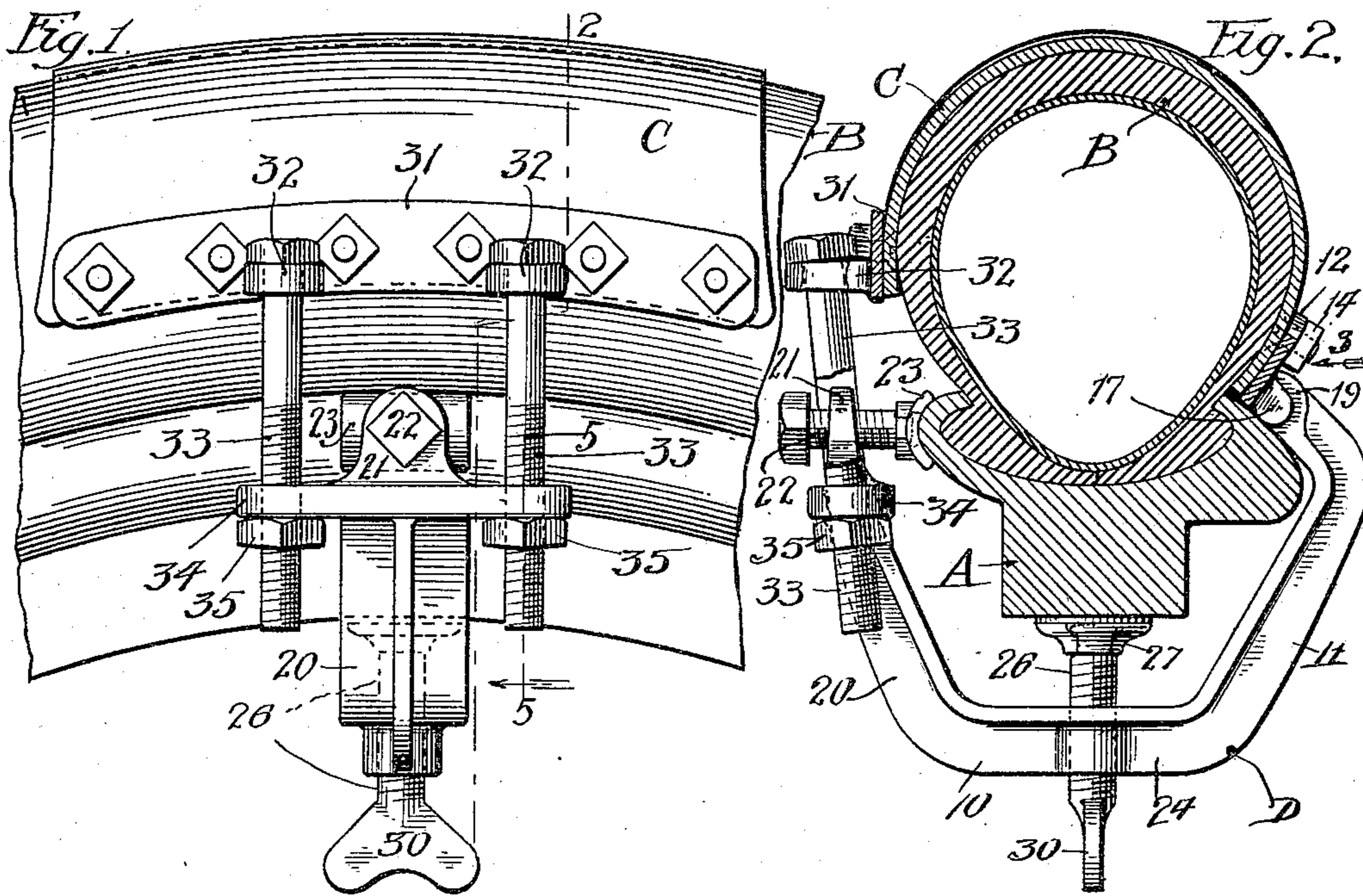

Witnesses:
James F. Richards
Charles A. Shervey

Inventor:
Axel Lundgren,
by Charles O. Shervey
his Atty.

UNITED STATES PATENT OFFICE.

AXEL LUNDGREN, OF CHICAGO, ILLINOIS.

BOOT-HOLDER.

999,382.

Specification of Letters Patent. Patented Aug. 1, 1911.

Application filed November 14, 1910. Serial No. 592,138.

To all whom it may concern:

Be it known that I, AXEL LUNDGREN, a citizen of the United States, residing at Chicago, in the county of Cook and State of Illinois, have invented a new and useful Improvement in Boot-Holders, of which the following is a specification.

This invention relates to boot holders of that class adapted for detachably securing a boot or blow out protector upon inflatable tires.

One of the objects of this invention is to provide a comparatively cheap, simple and efficient holder for firmly and securely holding the boot upon the tire.

Another object is to provide a holder which may be readily secured upon the rim of the wheel by clamping means, independent of the devices for tightening the boot upon the tire.

Another object is to provide a boot holder with an abutment member adapted to press against the rim so that when the tightening mechanism is drawn up, the pressure will be partly borne by the rim.

Another object is to provide a boot in which the breakable portions may be easily detached from the remaining parts and others substituted in their place.

Other objects and advantages will appear in the course of this specification and to such ends this invention consists in the several novel features of construction, arrangement and combination of parts hereinafter set forth in detail, and particularly pointed out in the claims.

The invention is clearly illustrated in the drawing furnished herewith in which:

Figure 1 is a side elevation of a fragment of a wheel rim having an inflated tire secured thereon and showing a boot and my improved boot holder applied thereto, Fig. 2 is a vertical cross section taken on the line 2—2 of Fig. 1, a tightening bolt being partly broken away to illustrate parts which would otherwise be hidden from view, Fig. 3 is a side elevation of a fragment of the boot and part of the holder, the view being taken in the direction indicated in the arrow 3, in Fig. 2, Fig. 4 is a detail vertical cross section taken on the line 4—4 of Fig. 3, Fig. 5 is a detail vertical cross section taken on the line 5—5 of Fig. 1, with the tightening bolt removed, and Fig. 6 is a side elevation of a slightly modified form of the invention.

Referring to said drawing, a wheel rim of ordinary construction is seen at A, said rim having detachably secured thereon an inflatable tire B. The construction of the rim and tire is well known to those skilled in the art and needs no further description. In case of a "blow out" or a weak spot in the tire, it has been customary to apply a boot or other removable protector thereto and to secure the same upon the tire by means of laces or mechanical devices for drawing it snugly down upon the same. Considerable time is necessarily spent in lacing the boot upon the tire and there is always the danger of the boot "creeping" along the tire in the use of the same. My improved holder has been designed to overcome this and other difficulties usually attendant in devices of this kind and will now be described.

A boot of ordinary construction is seen at C, and the same is usually made of some strong material such as leather or fabric and said boot is held in place upon the tire by the holder, D. In its preferred form the holder has a yoke shaped member 10, arranged to extend from side to side of the rim, as clearly shown in Fig. 2. One arm 11, of the yoke member 10, has detachably secured upon its end a plate 12, which is preferably curved to fit the general contour of the wheel and said plate is secured to the boot C, at one edge, as for instance by means of screws 13, and nuts 14, threaded thereon. The plate 12, is perforated to receive the screws and is countersunk as at 15, so that the heads of the screws may force the surrounding material of the boot into the countersunk portion in order that the heads of the screws may remain flush with or countersunk in the boot. The nuts bear against the outer faces of the plate and detachably secure the boot thereto. One form of means for detachably fastening the plate 12, to the yoke member 10, comprises a pivotal connection, here shown as a pivot pin 16, extending parallel with the plate 12, and offset therefrom by means of lugs 17, 17^a, the latter being notched as at 18, to permit the plate and yoke member to be separated. The end of the arm 11, is formed with a knuckle 19, arranged to hook over the pin 16, as shown in Fig. 4, and a gap is left in the knuckle to facilitate the detachment of the plate from the arm. By swinging the arm around until the gap registers with the

narrow portion of the lug 17^a, the arm may be slid sidewise to disconnect the parts.

The parts are preferably so arranged that the edge of the boot, which is connected with the plate 12, may rest in the angle between the tire and rim as shown in Fig. 2. The opposite arm 20, of the yoke member 10, has a head or cross bar 34, formed thereon and said arm may be extended up in the form of a lug 21, through which extends a set screw 22, adapted to clamp the holder upon the rim. Said screw preferably bears a plate 23, upon its end, which plate impinges upon the side of the rim A; the plate preferably being shaped to conform with the contour of the edge of the rim. It is evident that by tightening up the set screw 22, the yoke may be clamped upon the rim. To oppose the pulling action of the tightening screws, hereafter described, an adjustable abutment member is provided between the base member 24, of the yoke and the inner side of the rim. As shown in the drawing the abutment member may comprise a screw 26, threaded in the base member 24, of the yoke 10, and having a head 27, bearing against the inner side of the rim, a washer 28, preferably of rubber, usually being interposed between the faces of the head 27, and rim A. The screw 26, is provided with means whereby it may be turned and as shown may be formed with wings 30.

Secured upon the edge of the boot, opposite the edge bearing the plate 12, is a second plate 31, preferably curved to fit the general contour of the wheel as shown in Fig. 1, and said plate is attached to the boot by means of bolts and nuts in the same manner as is the plate 12. Projecting out from said plate 31, are a plurality of ears 32, through which extend tightening bolts 33, that pass through the head 34, of the yoke member 10, said bolts having nuts 35, threaded upon their lower ends and bearing against the underside of said head. The holes 36, in the ears 32, and head 34, are preferably elongated and inclined outward as seen in Fig. 5, so that the bolts may have a free tilting movement therein, because the tightening up of the nuts 35, causes the heads of the bolts 33, to move toward the vertical middle line of the tire after the plate 31, passes the horizontal center line thereof.

In the modified form shown in Fig. 6 the yoke 10^a, is provided with laterally projecting studs 34^a, upon which are secured buckles 33^a, which have straps 33^b, secured to them, that pass through openings 31^a, in the plate 31^b, the ends of the straps being brought back into locked engagement with the buckles. Screws 34^b, are provided upon the studs for holding the buckles against removal. In place of the straps chains may be substituted therefor, which may be suitably fastened to the yoke member and plate.

In applying the preferred form of the device to a wheel, the bolts 33, are first removed and the connecting yoke member 10, plate 12, and boot C, placed in the angle between the tire and rim. The yoke member is then swung under the rim, brought up into operative position, with the screw 22, in place in front of the rim, and said screw turned up against the rim to clamp the latter between the free ends of the yoke arms 20, 11, after which the screw 26, may be turned up to bear against the inner side of the rim. The device is now securely fastened upon the rim with the boot lapping over the tread of the tire. The bolts 33, may now be inserted through the openings in the ears 32, and head 34, and the nuts 35, screwed up on the bolts. If the device is placed upon the tire while the latter is in its inflated condition, the nuts should be tightened up until the boot is stretched taut upon the tire. If the device is placed upon the wheel while the tire is in a deflated condition, the nuts may be partly screwed up, allowing the expansion of the tire to stretch the boot into place. The nuts 35, should, however, be tightened up if the expansion is not sufficient to stretch the boot taut.

In the modified form the straps 33^b, are inserted through the holes 31^a, in the plate 31^b, drawn down to stretch the boot taut upon the tire, and afterward fastened in place in the buckles.

I am aware that various alterations and modifications of this device are possible without departing from the spirit of my invention, and I do not therefore desire to limit myself to the exact form of construction shown and described.

I claim as new and desire to secure by Letters Patent:

1. A boot holder of the class described, comprising in combination a boot arranged to be placed over the tire of a wheel, a boot holding member, one end of which is secured to one end of said boot, and arranged to bear against one side of a wheel rim, boot tightening means secured to the other ends of said boot and boot holding member, and a screw, threaded in said boot holding member at a point between the ends of said boot tightening means and arranged to bear against the side of the rim, opposite to the side engaged by said boot holding member.

2. A boot holder of the class described, comprising in combination, a boot a yoke piece, a plate secured to said boot and having a hinged connection with one arm of the yoke piece, and a boot tightening device upon the other arm of the yoke piece for putting tension upon the boot.

3. A boot holder of the class described, comprising in combination, a boot a yoke piece having a knuckle, a plate detachably secured to said boot and having a pivot pin

pivoted in said knuckle, and boot tightening means carried by the other arm of said yoke piece and arranged for connection with the boot.

- 5 4. A boot holder of the class described, comprising in combination, a boot a yoke piece, a plate adapted to be secured to said boot and pivotally connected with one arm of said yoke piece clamping means upon
10 the other arm for securing the holder upon a wheel rim, and boot tightening means carried by said second named arm and engaging with the boot, whereby the latter may be put under tension over a tire.
- 15 5. A boot holder of the class described, comprising a yoke piece arranged to be detachably secured upon a wheel rim, a boot, one edge of which is secured to one arm of said yoke piece and having laterally projecting lugs on its edge opposite the one
20 secured to said arm, and bolts extending through said lugs and adjustably connected with the second named arm of the yoke piece.
- 25 6. A boot holder of the class described, comprising in combination, a boot a yoke piece having an arm attached to said boot and arranged to bear against the side of a wheel rim, a set screw threaded in the
30 other arm of the yoke piece and adapted to bear against the opposite side of the wheel rim, a set screw threaded in said yoke and adapted to bear against the inner edge of the wheel rim, and bolts and nuts for connecting said boot and second named arm of

the yoke piece, whereby tension may be placed upon the boot by turning up the nuts.

7. A boot holder of the class described, comprising a yoke piece, a boot detachably
40 secured to one arm thereof, a plate secured to a free edge of said boot, and having ears extending out therefrom, a cross bar upon the other arm of the yoke piece, bolts passing through said ears and cross piece and
45 nuts threaded upon the bolts, substantially as and for the purpose set forth.

8. In a patching device for pneumatic tires, the combination with a rim and a tire mounted thereon, of a flexible patching strap
50 extending over the tread portion of said tire; and means for tightening said strap about said tire, said means comprising a clamp detachably clamped upon said rim, a jointed connection between one side of said
55 clamp and one end of said strap, connecting members having jointed connections with the other end of said strap and passing through slots in the opposite side of said clamp, and means threaded upon said con-
60 necting members for tightening said strap about said tire, substantially as described.

In witness whereof, I have hereunto set my hand at Chicago, Cook county, Illinois, this 10th day of November 1910.

AXEL LUNDGREN,

Witnesses:

CHARLES O. SHERVEY,
FANNIE F. RICHARDS.