

C. G. SCHMIDT & C. NAEGELEN.

MEAT ROLLER PRESS.

APPLICATION FILED NOV. 13, 1908.

965,336.

Patented July 26, 1910.

2 SHEETS—SHEET 1.

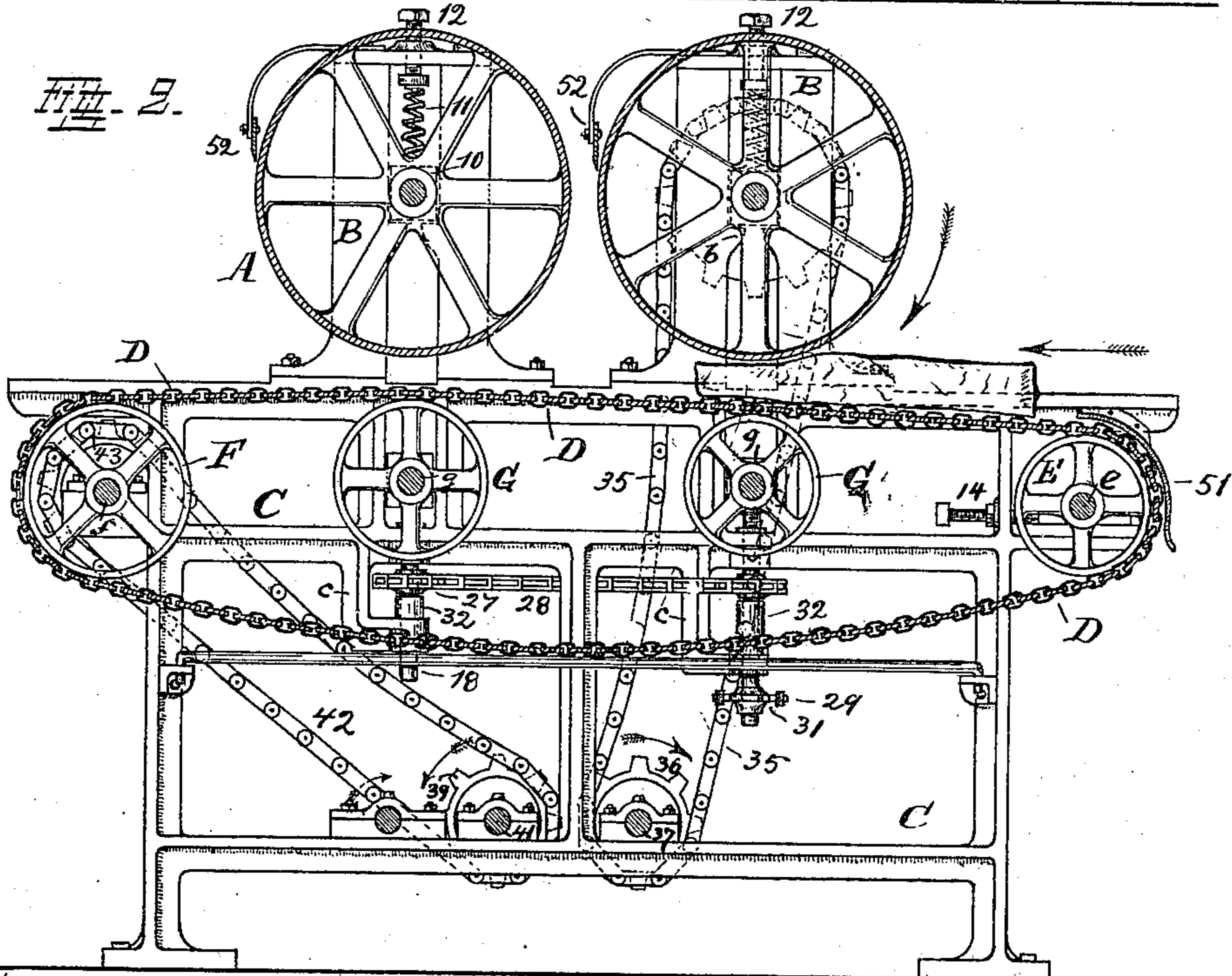
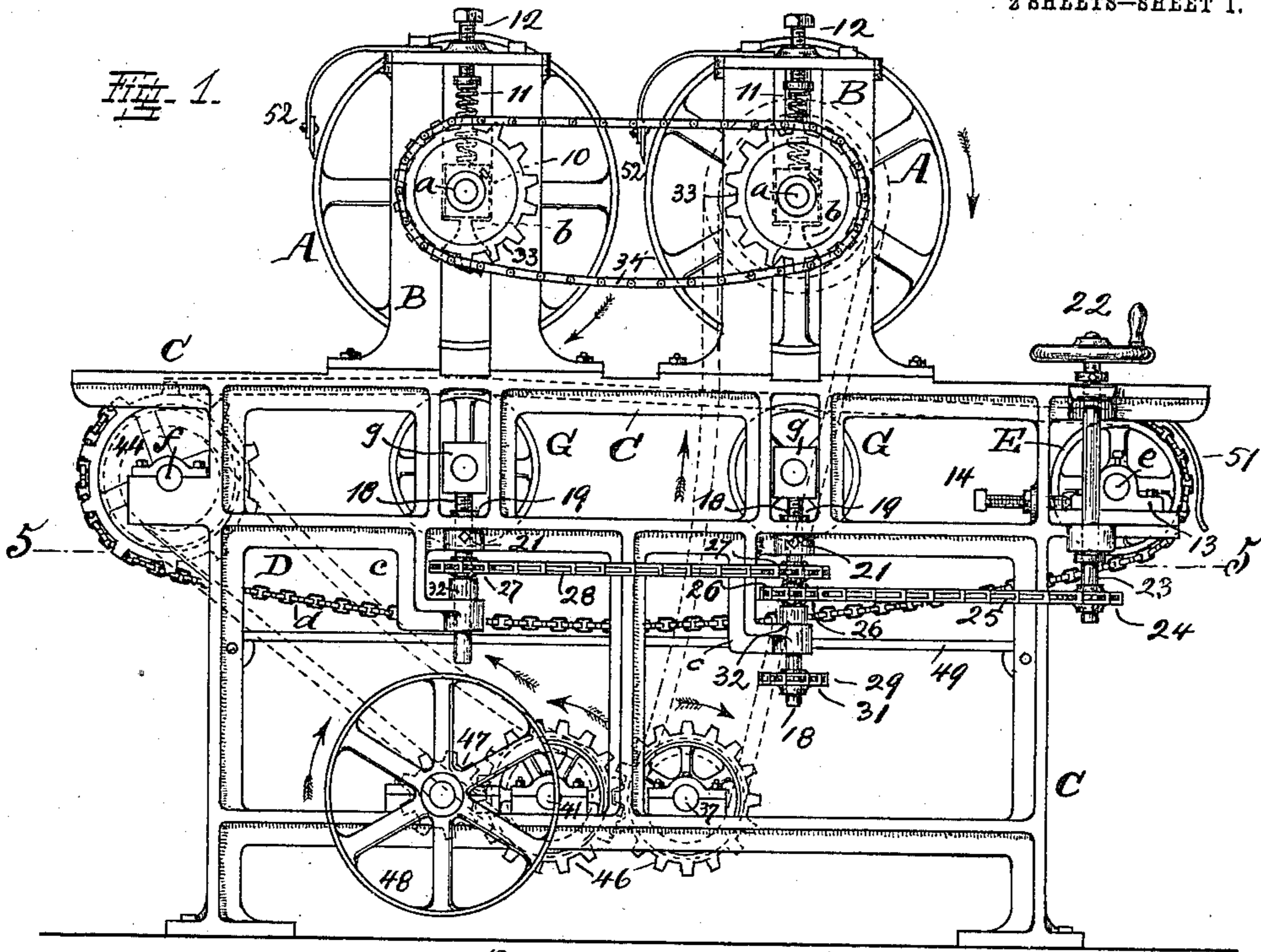

Witnesses.  
T. Lebeau.  
James H. ...

Inventors.  
Charles G. Schmidt  
Charles Nagelen  
by C. Spengel Atty.

C. G. SCHMIDT & C. NAEGELEN.

MEAT ROLLER PRESS.

APPLICATION FILED NOV. 13, 1908.

965,336.

Patented July 26, 1910.

2 SHEETS—SHEET 2.

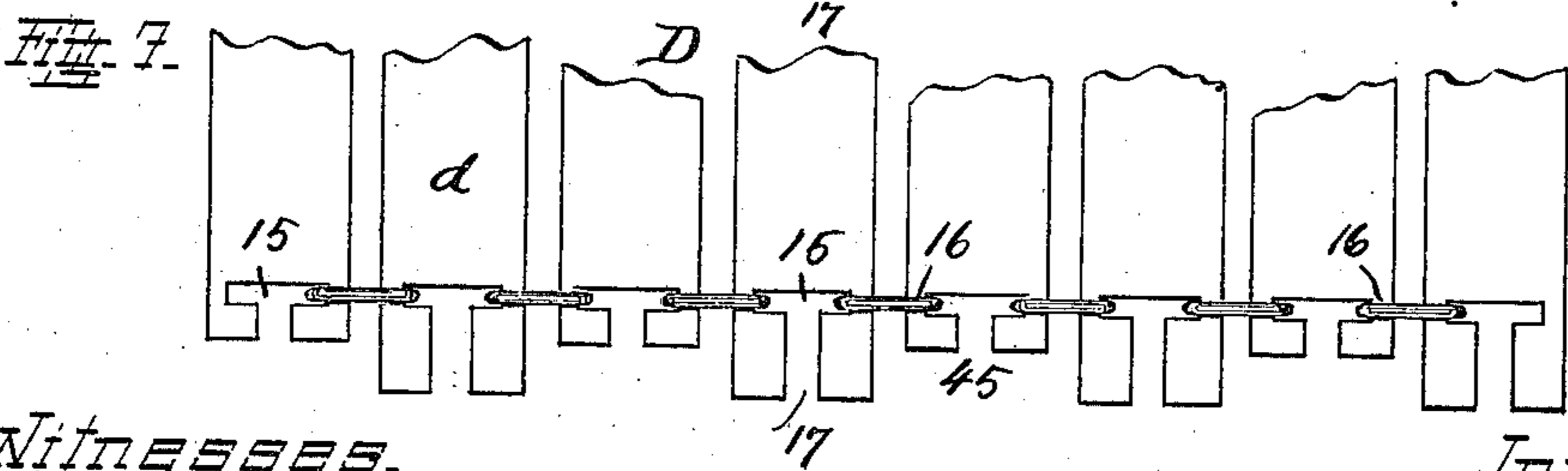
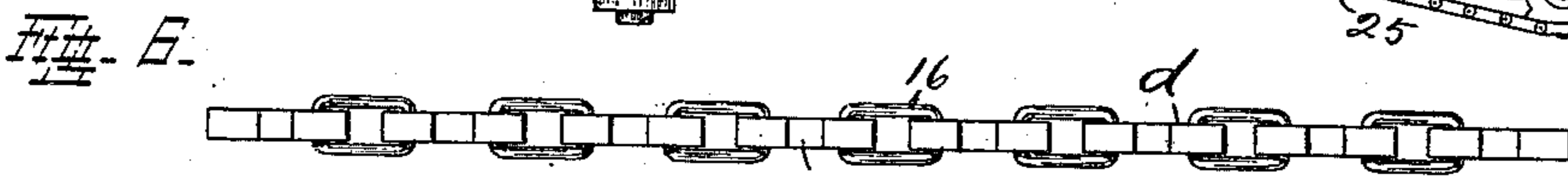
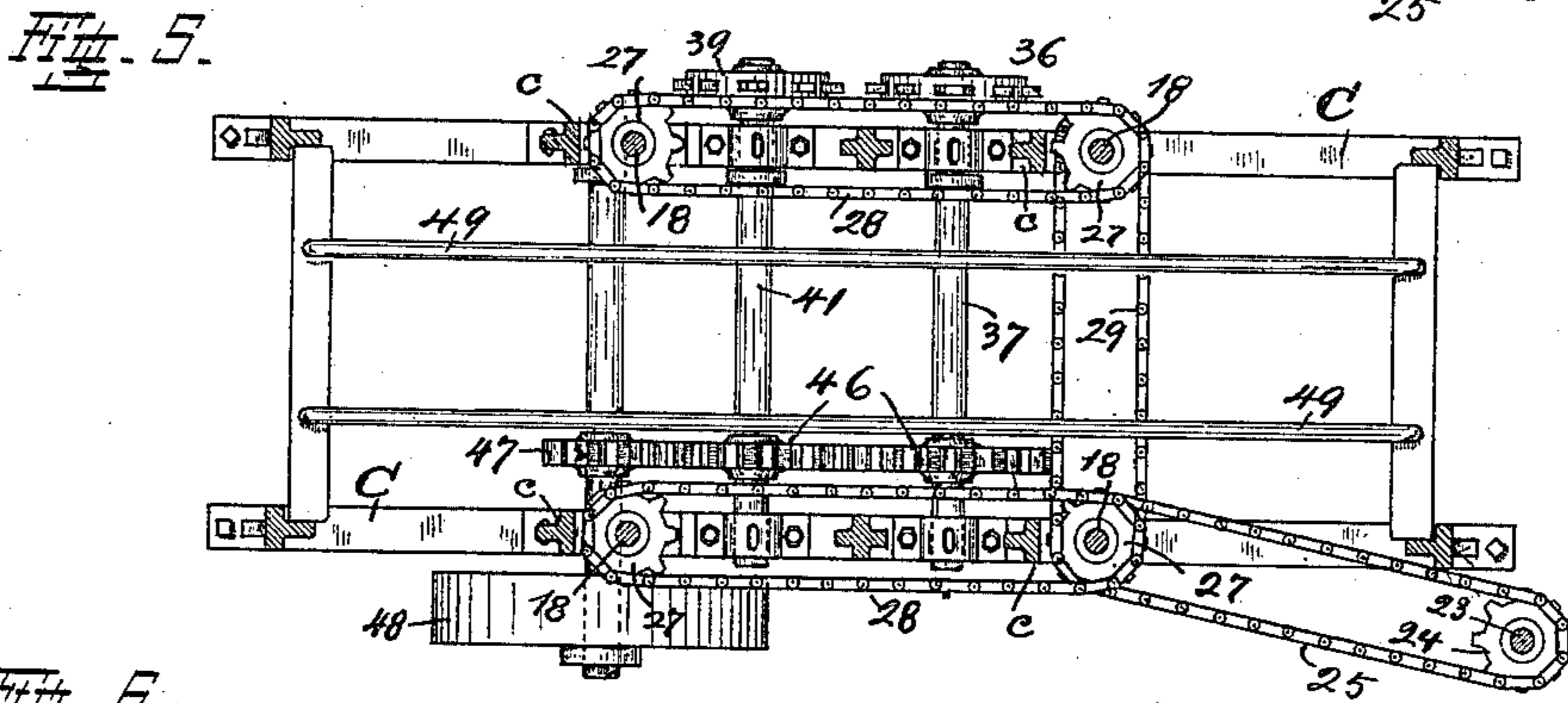
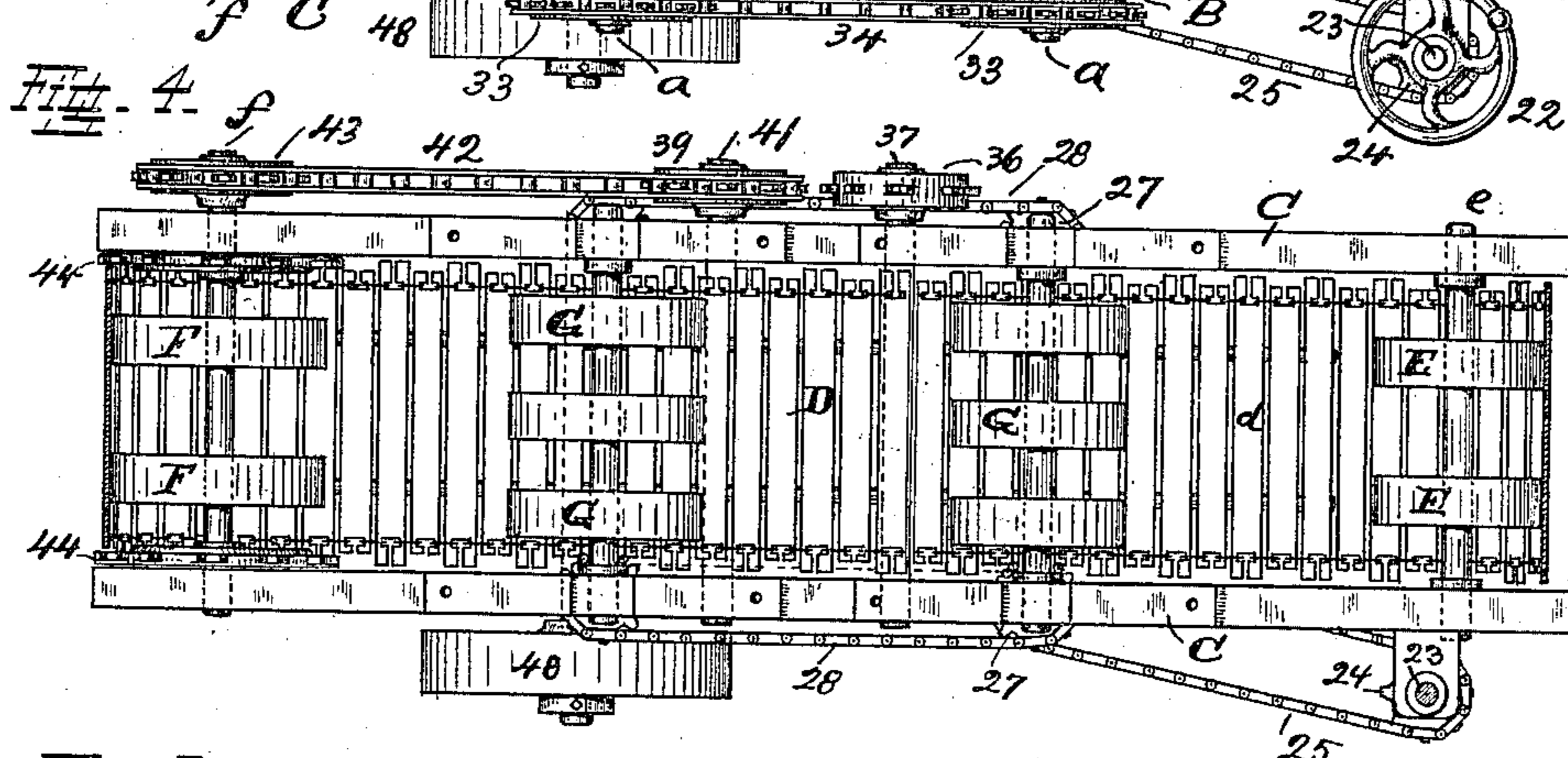
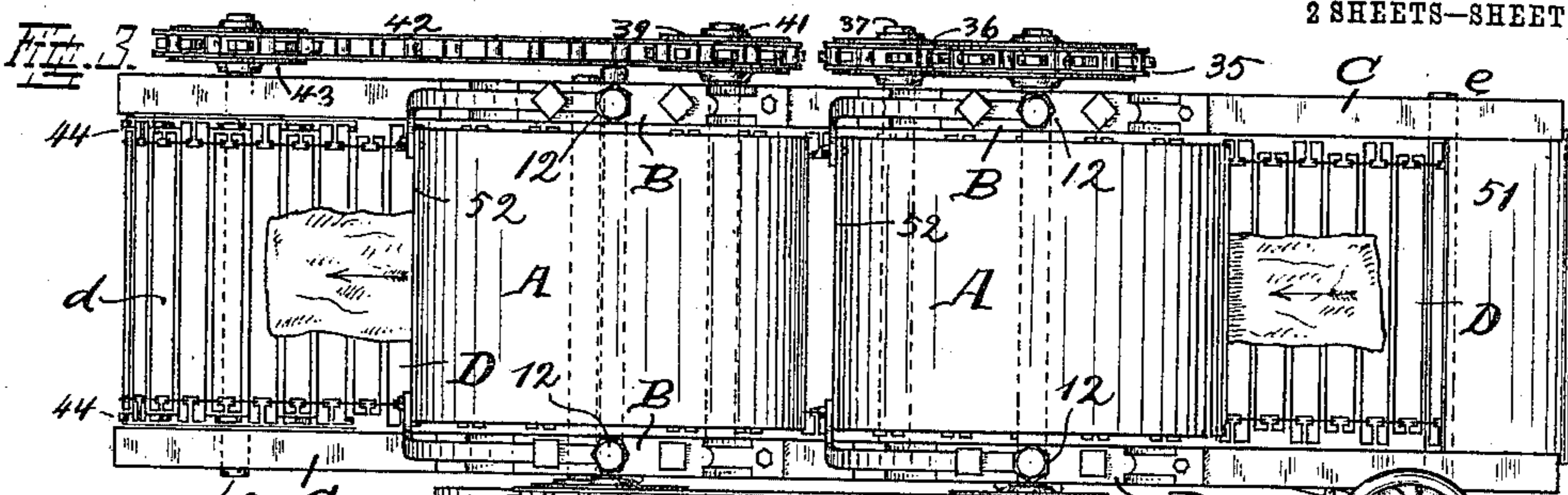

Witnesses.  
T. LeBeau.  
James Hickler

Inventors.  
Charles G. Schmidt  
Charles Nagelen  
by C. Spengel Atty.

# UNITED STATES PATENT OFFICE.

CHARLES G. SCHMIDT AND CHARLES NAEGELEN, OF CINCINNATI, OHIO, ASSIGNORS  
TO THE CINCINNATI BUTCHERS SUPPLY COMPANY, OF CINCINNATI, OHIO, A COR-  
PORATION OF OHIO.

MEAT ROLLER-PRESS.

965,336.

Specification of Letters Patent. Patented July 26, 1910.

Application filed November 13, 1908. Serial No. 462,384.

*To all whom it may concern:*

Be it known that we, CHARLES G. SCHMIDT and CHARLES NAEGELEN, both citizens of the United States, and residents of Cincinnati, Hamilton county, State of Ohio, have invented a certain new and useful Meat Roller-Press; and we do declare the following to be a clear, full, and exact description of the invention, attention being called to the accompanying two sheets of drawings, with the reference characters marked thereon, which form also a part of this specification.

This invention relates to an improved machine for reducing meat, like a side of bacon for instance, to uniform thickness, the action being by pressure.

The object is to smoothen the opposite surfaces of pieces of meat, to flatten them to facilitate packing for shipping and to improve the appearance of the meat. The desired effect is obtained by the application of pressure by means of rolls, a feed-device being used to move the meat through a contracted space the side of which is controlled by the rolls.

The invention consists of the particular construction as hereinafter described and claimed and as illustrated in the accompanying two sheets of drawings, in which:—

Figure 1, is a side-elevation of the machine. Fig. 2, is a longitudinal, vertical section of the same, taken behind the side-frame appearing in Fig. 1. Fig. 3, is a top-view of the machine. Fig. 4, is a similar view with the upper rolls and the upper part of the endless conveyer removed. Fig. 5, is a horizontal section of the machine taken on line 5—5 of Fig. 1, no part of the lower branch of the conveyer being shown. Fig. 6, is an enlarged edge-view of the conveyer. Fig. 7, is a top-view of the conveyer, showing a portion of it near one of its edges.

A, A, are two pressure-rolls of cylindrical shape. They have journals *a, a* at opposite ends and are mounted in boxes 10 for rotation. These boxes are supported in slotted housings B, B, and occupy a normally lowest position in them by resting upon shoulders *b, b* projecting from opposite sides of the slots provided in said housings. Springs 11—11 are provided above these boxes and resist yieldingly any action to lift a roll. The resistance exercised by the pressure of

these springs may be adjusted by means of screws 12—12, seated in the upper part of the housings. These latter are supported on two side-frames C, C, spaced parallel from each other and of suitable shape and dimensions to provide bearings and supports for the various machine-elements to be presently described.

D is a movable table or apron rendered flexible by being composed of a number of slats *d*, spaced parallel and linked together by articulated joints to form an endless conveyer. This conveyer or apron is supported below pressure rolls A A, and is of sufficient length to permit placing of the meat in front of these rolls that is opposite the face of one of them and to convey it through below them. For the purpose of so supporting the apron, guide-rollers are mounted at opposite ends of the machine and properly spaced to carry the apron around where it makes the turns. Sufficient surface is provided by the faces of these pulleys, to properly support the apron transversely between its edges, and this surface may be provided by pulleys of sufficient width of the face, one at each end, or by a number of them at each end laterally spaced apart. We use a plurality of them at each end, there being two rollers E, E, at one end mounted upon a shaft *e*, and two rollers F, F, at the other end mounted upon a shaft *f*.

Suitable means are provided to hold the apron at proper tension, a preferable way being by supporting one set of these rollers adjustable to or from the other set. For such purpose boxes 13 in which shaft *e* is mounted, are supported to be movable on the machine-frame, screws 14 being used to adjust their position. Slats *d* are made of metal and the manner of joining them to each other, to make up the endless conveyer, is best illustrated in Figs. 6 and 7. They have perforations, one close to each of their ends as shown at 15, the openings being sufficiently elongated to permit insertion of links 16, whereby they are connected. These links are of a shape which does not require special manufacture like sprocket-chains and may be hand-forged.

To facilitate assembling of the slats, we use a construction whereby these links may be completed and closed before being placed in position between two adjacent slats. For

such purpose perforations 15 at the ends of the slats are rendered open outwardly by notching all slats endwise at both ends as shown at 17, which notches communicate with these perforations. It will now be understood that these links may be readily placed in position within openings 15, by entering them through notches 17. They find and maintain their proper position in opposite ends of these openings, as soon as the conveyer is stretched by means of screws 14. The advantage of this arrangement is that an apron may be readily made up to proper length, and again, if the range of adjustment made possible by screws 14, is insufficient to take out for instance an excess of slack, a number of the slats may be taken out. This is readily done in view of the construction shown, which permits links 16 to be taken out through notches 17, the tension in the apron having first been reduced if necessary, by moving screws 14, accordingly. Additional slats may be inserted in a similar manner if the conveyer is too short.

The conveyer may move in either direction, and as shown in the drawing, it moves in the direction of the arrows, rotary parts revolving accordingly.

The meat is carried through under rolls A, A, while resting upon the upper branch of the conveyer, as shown in Figs. 2 and 3, and is thus compressed between them. The movement of the meat is a positive one and due to the fact that the slats are spaced apart in a manner which permits the meat to enter these spaces to an extent sufficient to permit the edge of the slats to engage the meat to move it. In order to sustain the conveyer unyieldingly opposite rolls A A, and to relieve any strain tending to stretch it, we provide supporting means below the same, and opposite rolls A A in form of additional rolls G, G, having journals at opposite ends whereby they are supported in boxes *g, g*. There may be one roll G, of sufficient width under each roll A, or a plurality of pulley-shaped wheels as shown in Fig. 4.

As will be seen in Fig. 2, a side of meat is carried by apron D, first under one roll A, and then under the other one. In constructing this part of the machine, we arrange that the amount of compression a piece of meat is subjected to, is divided between the rolls, that is to say while passing under the first roll a side of meat is compressed to a certain extent, after which additional compression is applied while passing under the second roll. For such purpose the space between the first roll and the conveyer is larger than the space between this latter and the second roll. This effect may be obtained by arranging the diameter of the co-acting, that is opposite rolls correspond-

ingly, and it is done here by making rolls G, under the first roll A smaller in diameter than the other roll G.

The compression space below rolls A A, is adjusted by positive means to suit the thickness of the meat to be passed through. For such purpose we provide for the vertical adjustment of rolls G, which is done by supporting boxes *g g*, in which they are mounted movable in frame C. Screws 18 are provided upon which these boxes rest and which screws are fitted to nuts 19. These nuts may be formed in frames C, or they may be inserted into them, in which case they are held against rotation by set-screws 21, or by other equivalent means. It is obvious that if these screws are rotated, they will move vertically in their nuts, and move boxes *g g* accordingly. It is desirable that for such adjustment, at least the two boxes supporting one roll may be moved together, and by preference those of the other roll are also moved at the same time, so that any desired adjustment may be had by one manipulation. For such purpose screws 18 are extended downwardly to form shafts and supported at their lower ends in bearings formed by suitable brackets *c c*, which may be attached to frame C, or form parts thereof. Certain machine-elements are mounted upon these four screw-shafts and operatively connected in a manner so that if one of them is positively rotated, they all rotate. This positive rotation is obtained by manipulating a handle or hand-wheel 22, mounted upon a shaft 23, the latter being operatively connected to one of the four-screw-shafts. We use chain-wheels for this purpose, there being one 24 connected by a chain 25, to a chain-wheel 26 on one of the four-screw-shafts. Additional chain wheels 27, are mounted, one each on the other screw-shafts, and by means of two chains 28, these four chain-wheels, two by each chain, are operatively connected. An additional chain 29 is used whereby from one set of two operatively connected shafts, the other set of the two shafts is rotated. One shaft in each of the two connected sets is for such purpose made longer and provided with a chain-wheel 31. It will now be seen that when hand-wheel 22 is operated, all four screw-shafts move in their nuts, and either raise or lower boxes *g g*. Only chain-wheels 31 are rigidly connected to their respective screw-shafts, the other chain-wheels are by preference mounted for rotation only, but permit the screw-shafts to move vertically in either direction. The well known spline, or key and groove connection, is for such purpose resorted to, the groove by preference being in the screw-shafts. Sleeves or spacing collars 32 are interposed to maintain the chain-wheels in proper position horizontally. The extent of the adjusting movement be-

ing the same for each of the lower rolls, it follows that the particular relation of the compressing spaces, the space under the first roll A, being larger than the space under the other roll, is always maintained. That is to say the first compressing space is always larger than the other space, no matter to which particular position the lower rolls have been adjusted.

Positive movement is imparted to the apron and to the upper rolls only. Of these latter one roll drives the other, chain-wheels 33 being mounted on their journals, which latter are extended on one side, and a chain 34 is used to connect them, (see Fig. 1). On the other end of one of the rolls there is also a chain-wheel driven by means of a chain 35, from a chain-wheel 36, mounted on a shaft 37 as shown in Fig. 2. Another chain-wheel 39 on a shaft 41 drives by means of a chain 42, another chain-wheel 43, on one of the shafts at the ends of the conveyer, shaft *f* being so used and driven. Toothed wheels 44, see Figs. 1 and 3, are mounted on this shaft and so spaced thereon as to engage apron D at its edges. The teeth of these wheels enter spaces 45 between alternate slats *d*, said spaces being obtained by shortening the intermediate slats, see also Figs. 6 and 7.

It will be observed that conveyer D is adapted to be directly engaged by wheels 44, to be moved by them without the intervention of any other means. Of the shafts 37 and 41, one moves the other, intermeshing gear-wheels 46 being mounted at their other ends. One of these is driven by a pinion 47, power being applied to a pulley 48, mounted on the pinion-shaft. Auxiliary devices like chain tighteners may be applied wherever required.

Guards 49 in form of two rods are supported on the machine-frame and below the conveyer. Their object is to prevent any parts of the conveyer in case of a break, from dropping onto any of the moving parts below.

51 is a shield at the feed-end of the conveyer to protect the attendant thereat while placing the meat.

52 are scrapers in yielding contact with the rolls serving to keep them clean.

Obviously the form of conveyer shown may be used in connection with pressing means arranged differently from those shown. Thus for instance one upper roll only may be used.

Having described our invention, we claim as new:

1. In a meat roller-press, the combination of a plurality of press-rolls, a meat conveyer arranged to pass below them with a space between, rolls to support the conveyer opposite each press-roll, boxes for the journals of

these rolls, screw-shafts vertically supported below these boxes and upon the upper ends of which these boxes rest, chain-gear whereby all these screw-shafts are connected for simultaneous rotation and means to actuate one of these screw-shafts.

2. In a meat-press, the combination of an endless meat conveyer having notches which extend opposite each other inwardly from its edges, pressing means arranged above the same, and toothed wheels mounted for rotation below the notched edges of the conveyer and adapted to engage them for the purpose of moving the conveyer with reference to the pressing means.

3. In a meat-press, the combination of a conveyer formed of slats arranged parallel to each other, with spaces between them and linked together to form an endless apron, pressing means arranged adjacent to this apron and toothed driving-wheels, the teeth of which are adapted to enter the spaces between the slats and by engaging these latter edgewise, serve to move the apron past the pressing means.

4. A conveyer suitable for use in a pressing-device and formed of slats, arranged parallel to each other and linked together, alternate slats being shorter at both ends to produce spaces between the slats adjoining them, combined with wheels mounted for rotation and having teeth adapted to enter the spaces between the slats mentioned to engage the longer slats for the purpose of moving the conveyer with reference to the pressing means.

5. A conveyer suitable for use in a pressing-device and formed of slats having perforations at their opposite ends and arranged parallel to each other, links which occupy these perforations and thereby connect the slats to form an endless apron, the slats being notched endwise, which notches communicate with the perforations mentioned to render them open to permit insertion or removal of the links.

6. In a meat-press, the combination of pressing-means, a meat-conveyer consisting of linked members, means to move the same with respect to the pressing means, mechanism arranged below the conveyer for adjusting the position of the operating parts, a frame on which all these parts are mounted and guards supported on the frame and below the conveyer and between it and the operating mechanism mentioned.

In testimony whereof, we hereunto affix our signatures in the presence of two witnesses.

CHARLES G. SCHMIDT.  
CHARLES NAEGELEN.

Witnesses:

C. SPENGLER,  
T. LE BEAN.