

900,951.

O. S. PROCTOR.
TUNNELING MACHINE.

APPLICATION FILED FEB. 17, 1908.

Patented Oct. 13, 1908.

4 SHEETS—SHEET 1.

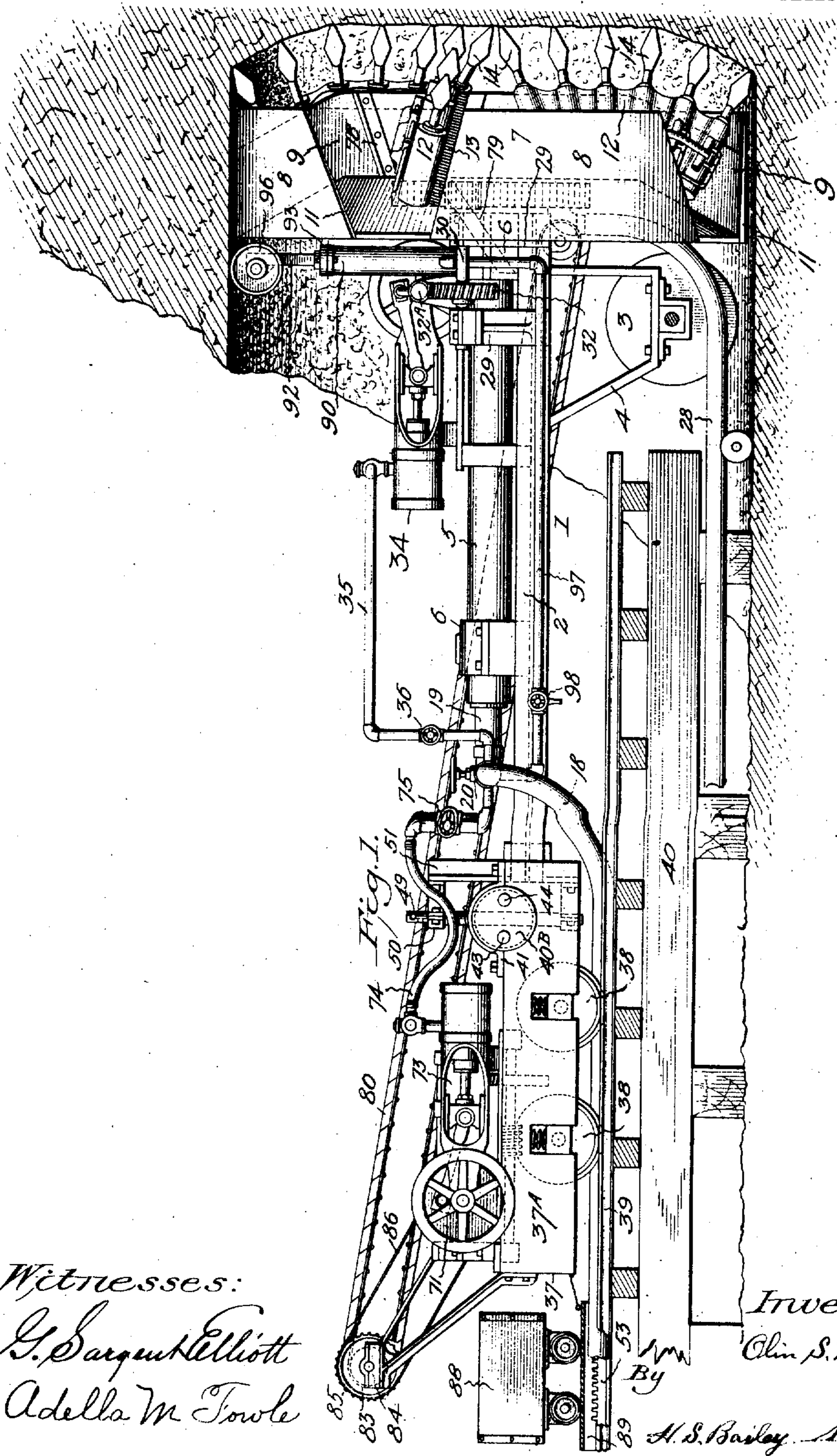

Witnesses:
G. Sargent Elliott
Adella M. Towle

Inventor:
Olin S. Proctor

By
A. S. Bailey Attorney

900,951.

O. S. PROCTOR.
TUNNELING MACHINE.

APPLICATION FILED FEB. 17, 1908.

Patented Oct. 13, 1908.

4 SHEETS—SHEET 2.

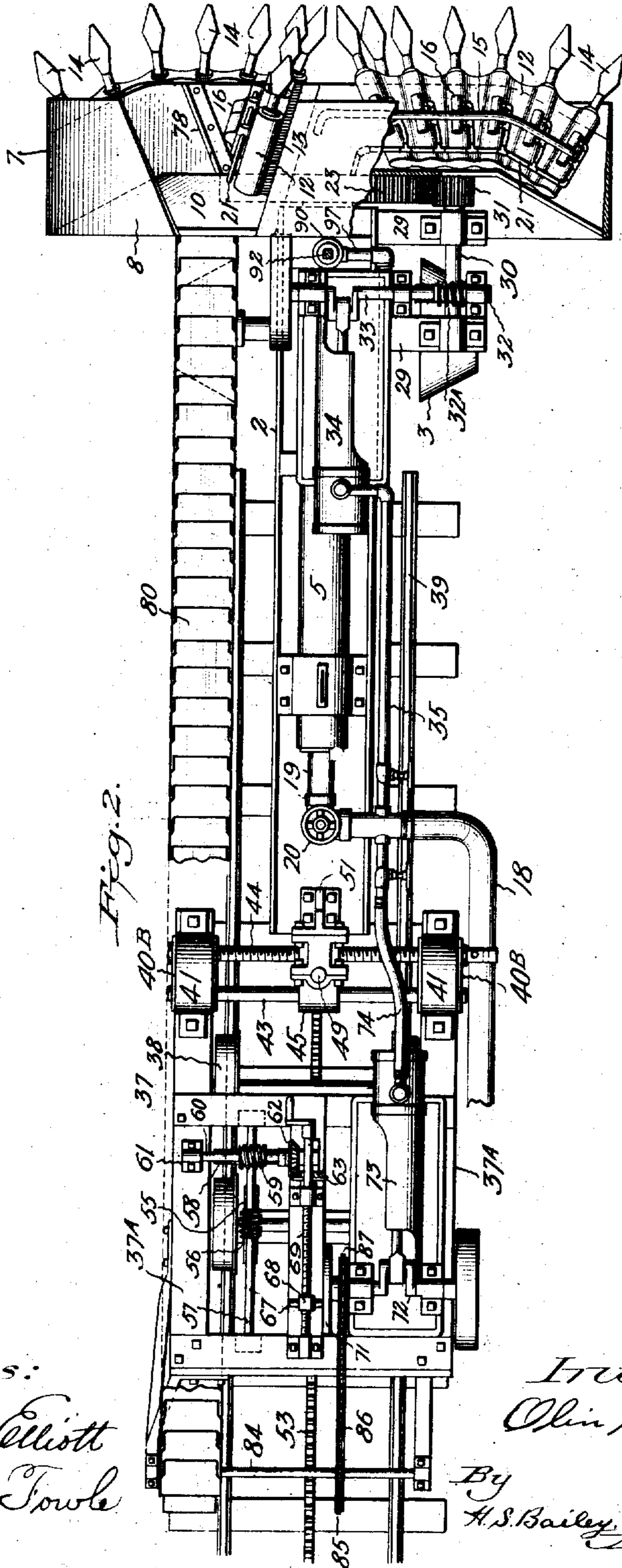

Witnesses:
G. Sargent Elliott
Adella M. Towle

Inventor:
Olin S. Proctor.

By
H. S. Bailey, Attorney.

O. S. PROCTOR.
TUNNELING MACHINE.

APPLICATION FILED FEB. 17, 1908.

900,951.

Patented Oct. 13, 1908.

4 SHEETS—SHEET 3.

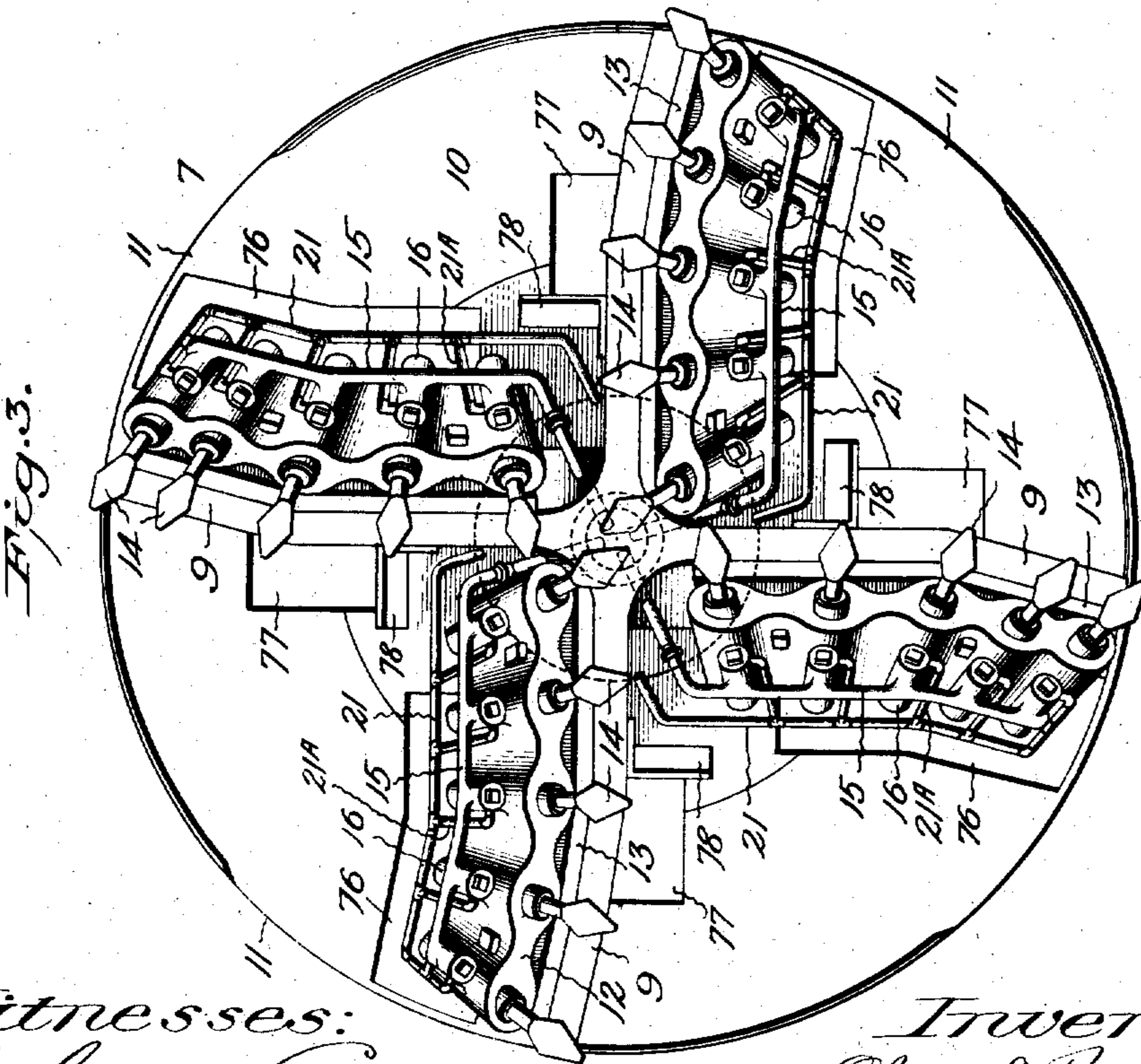
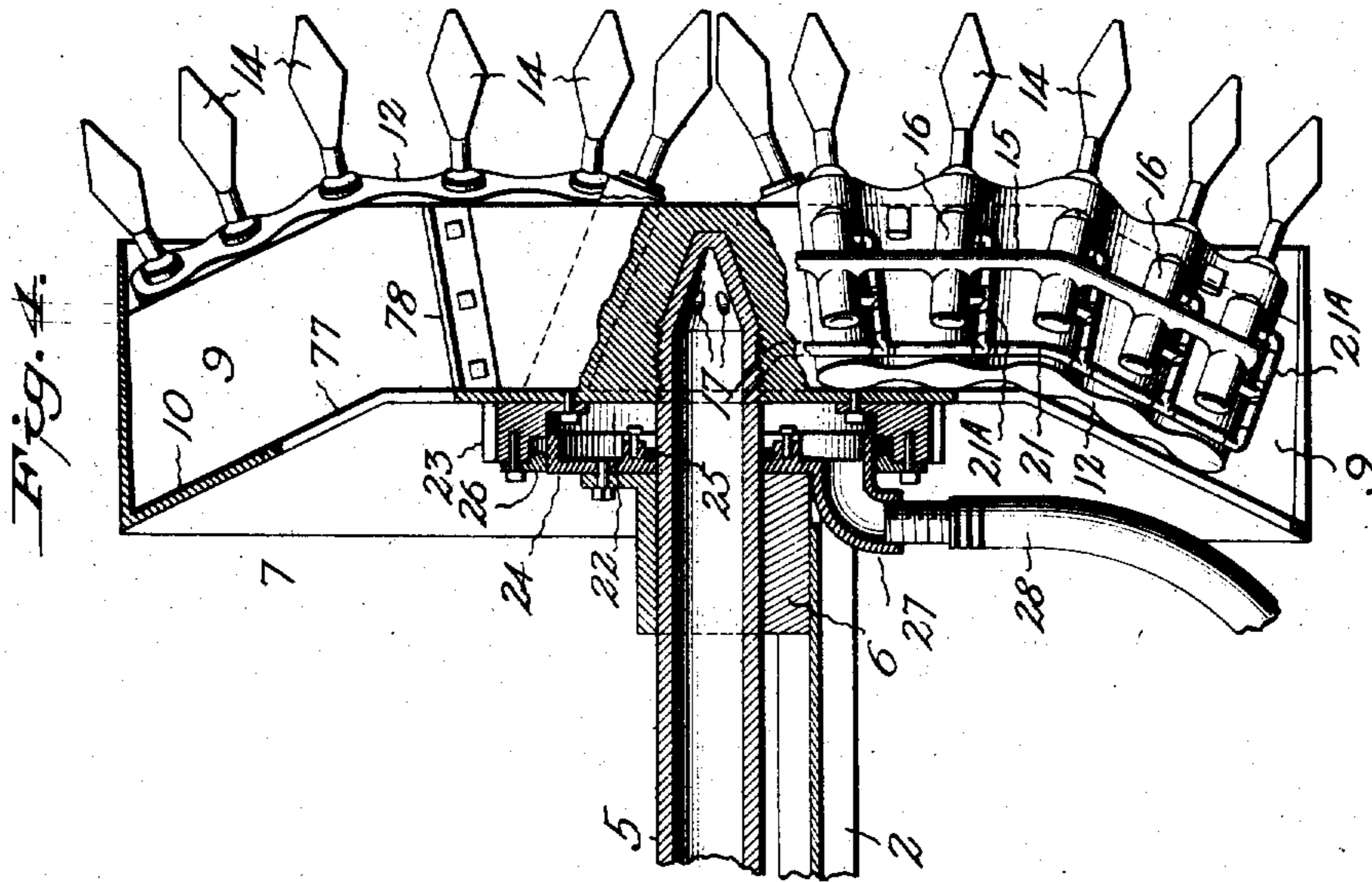

Witnesses:
G. Sargent Elliott
Adella M. Towle

Inventor.
Olin S. Proctor

By
H. S. Bailey, Attorney.

O. S. PROCTOR.
 TUNNELING MACHINE.
 APPLICATION FILED FEB. 17, 1908.

900,951.

Patented Oct. 13, 1908.
 4 SHEETS—SHEET 4.

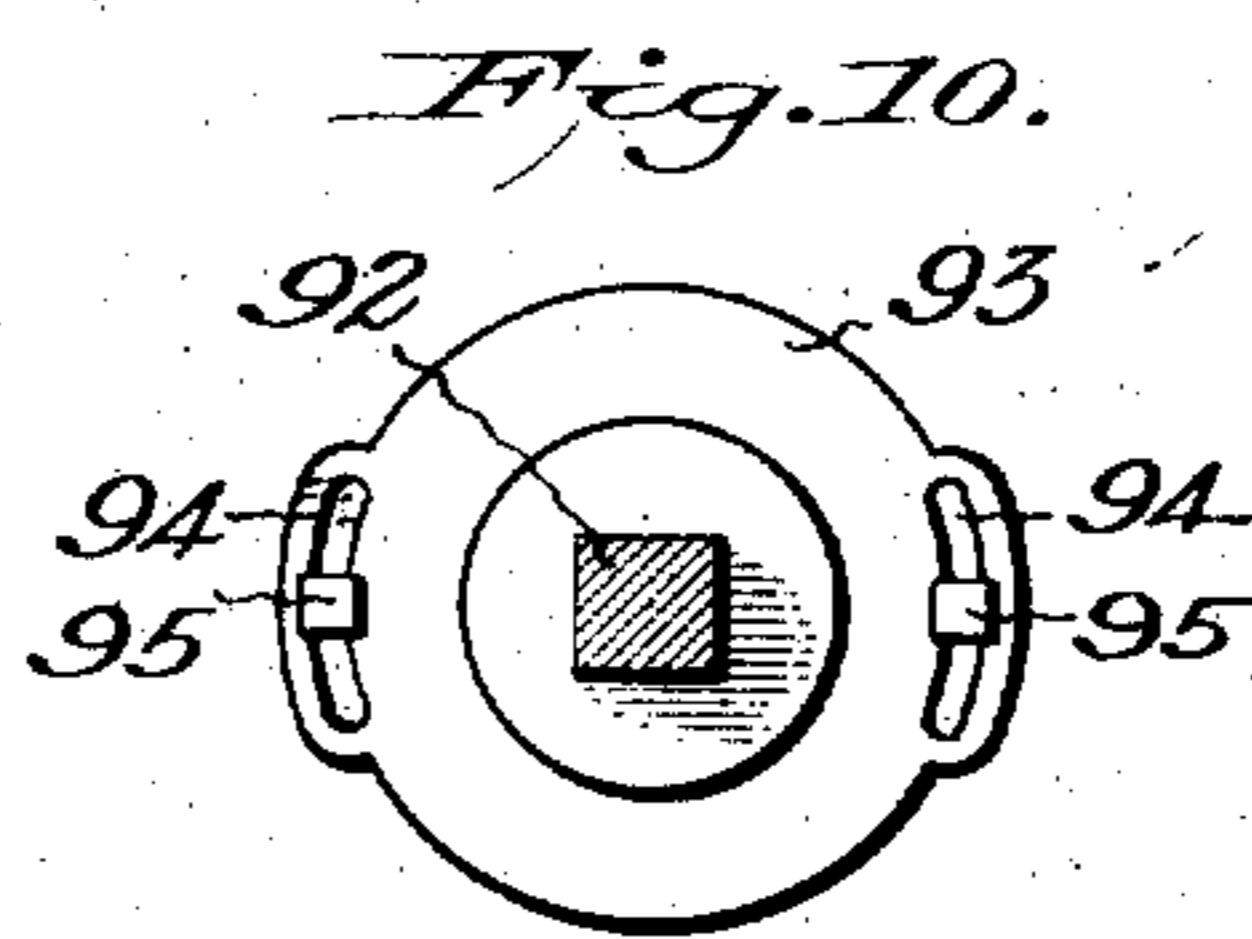
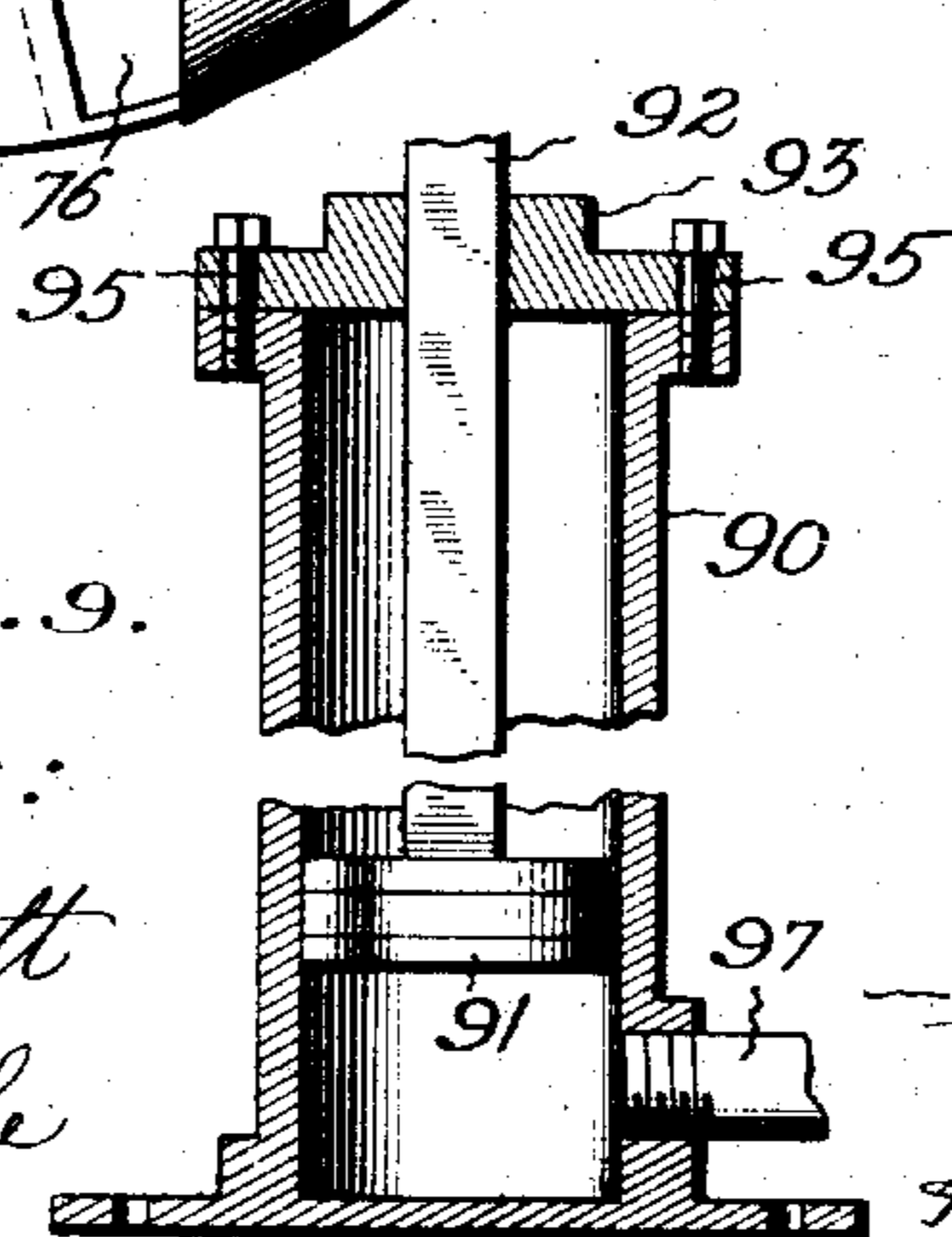
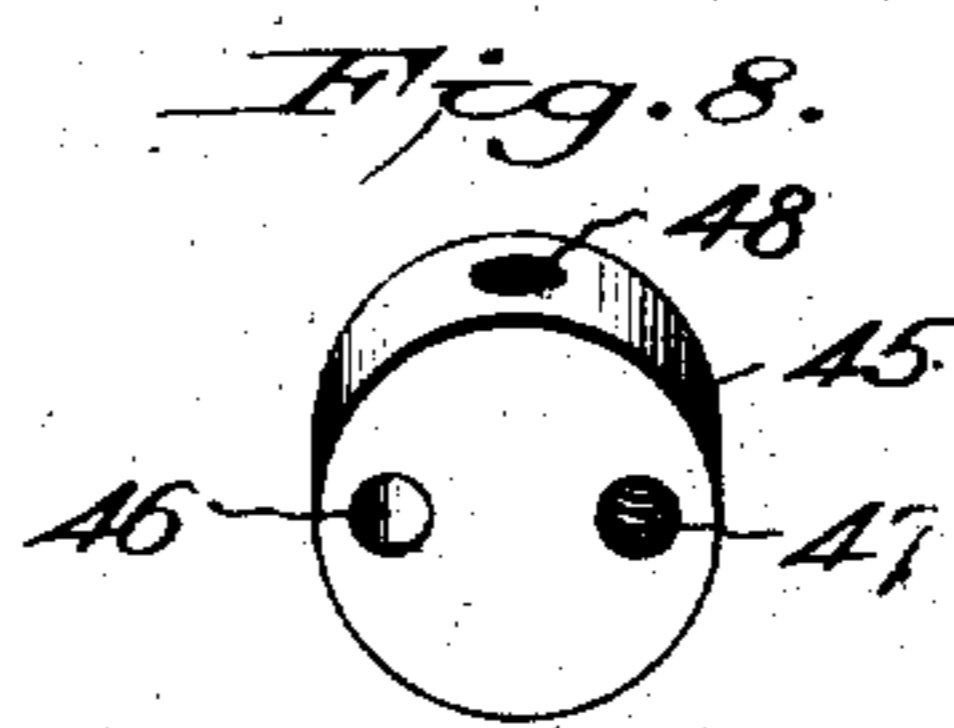
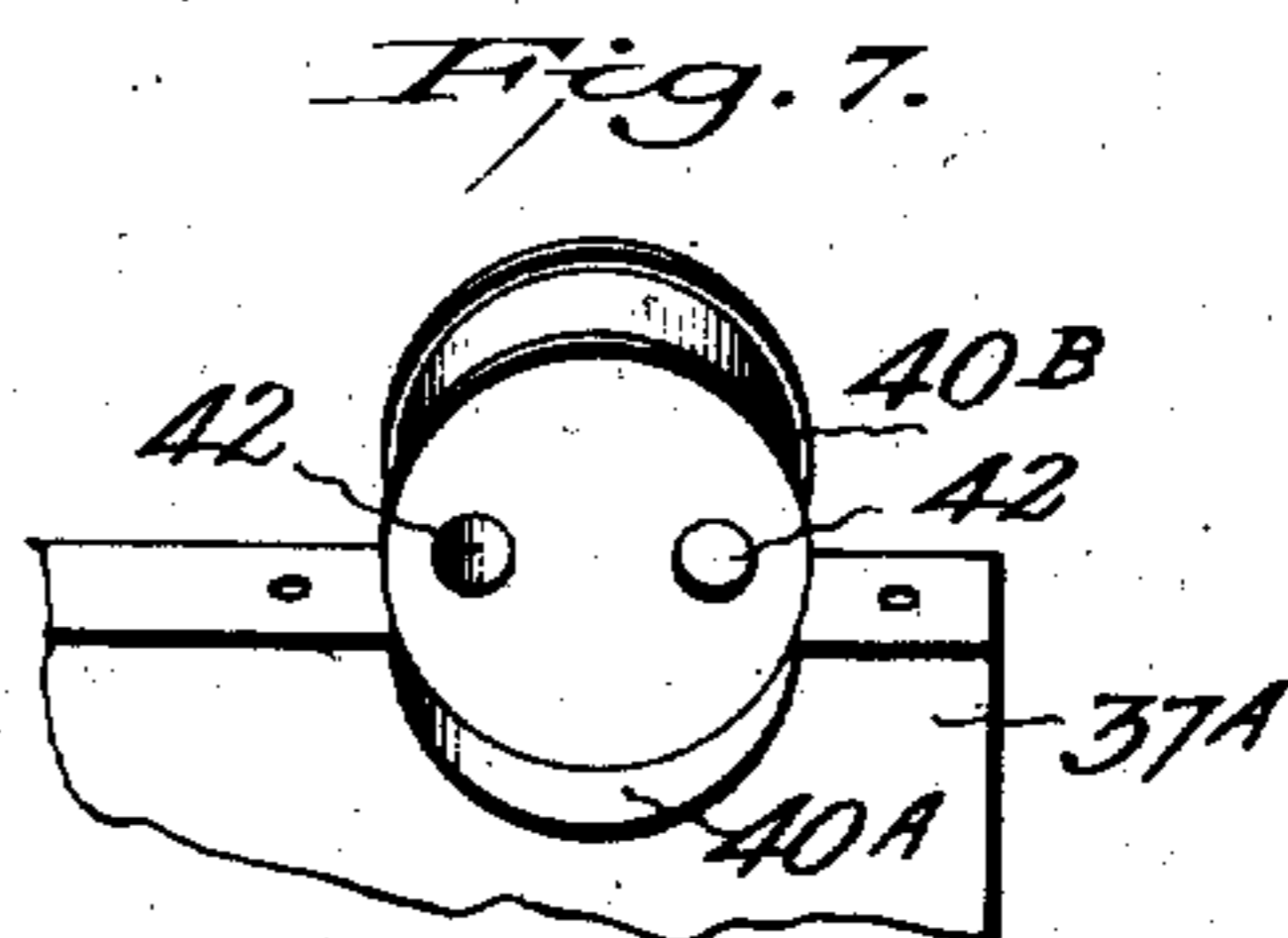
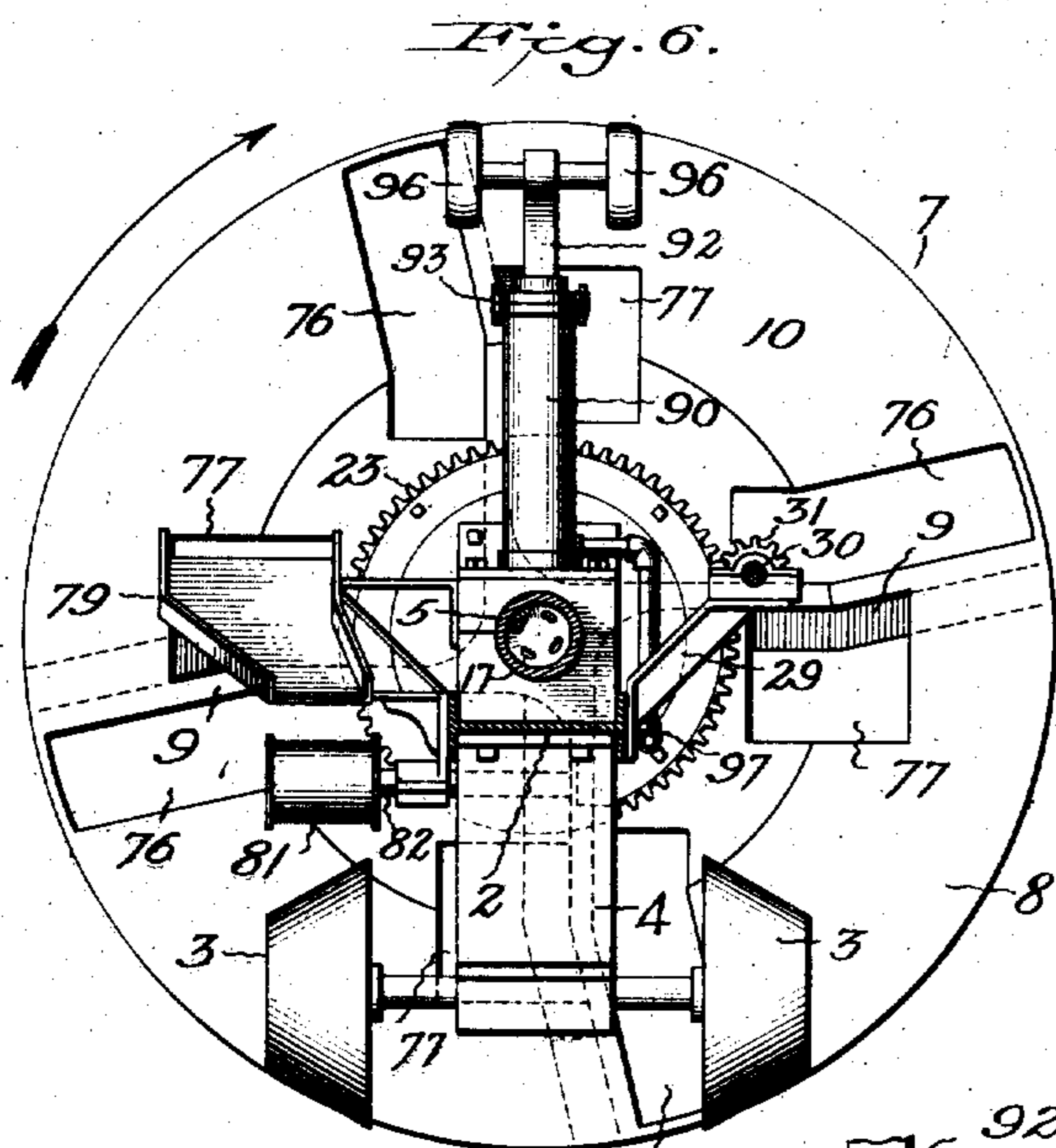
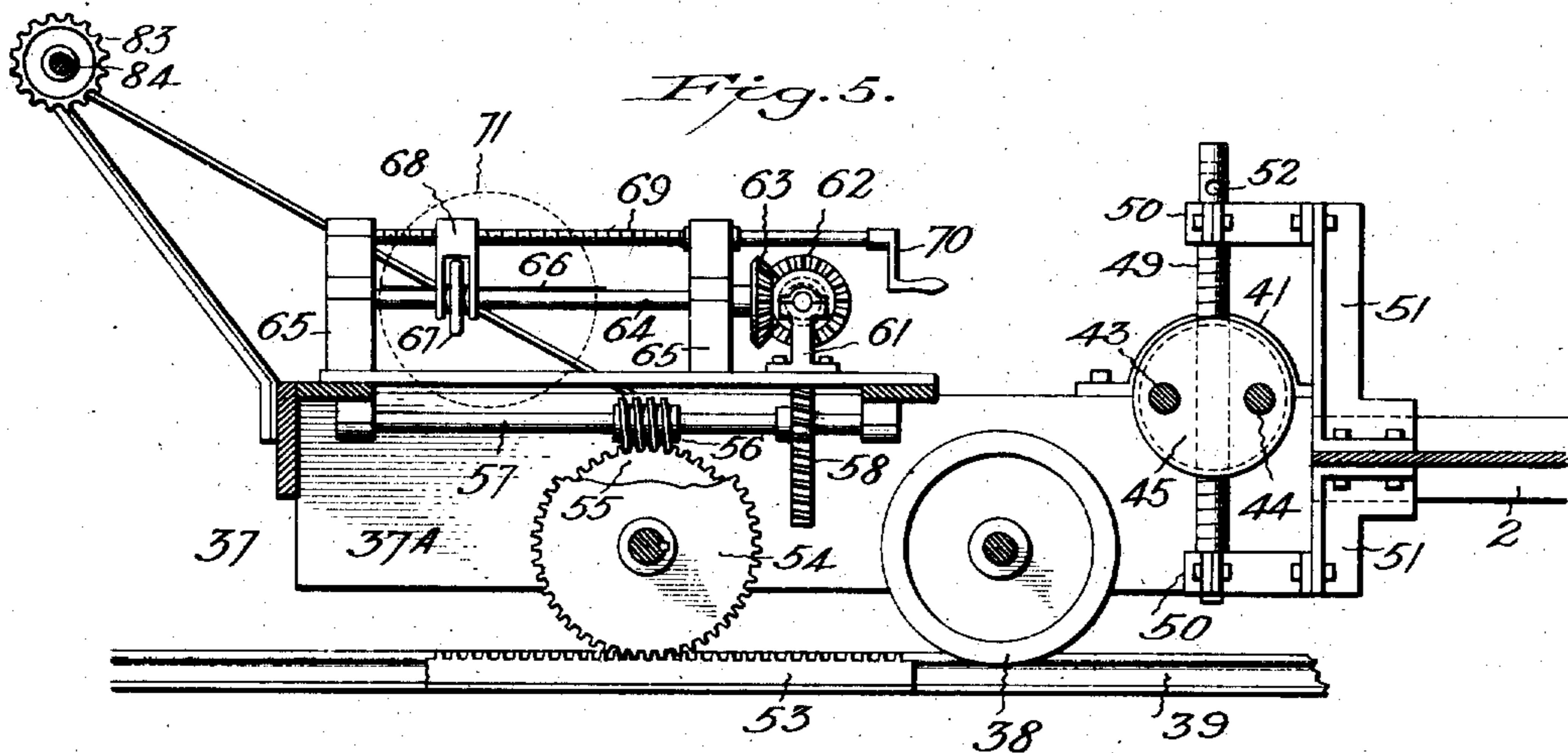

Witnesses:
 G. Dargent Elliott
 Adella M. Towle

Inventor:
 Olin S. Proctor.
 By
 H. S. Bailey, Attorney.

UNITED STATES PATENT OFFICE.

OLIN S. PROCTOR, OF DENVER, COLORADO, ASSIGNOR, BY MESNE ASSIGNMENTS, TO THE TERRY, TENCH & PROCTOR TUNNELING MACHINE COMPANY, A CORPORATION OF NEW YORK.

TUNNELING-MACHINE.

No. 900,951.

Specification of Letters Patent.

Patented Oct. 13, 1908.

Application filed February 17, 1908. Serial No. 416,374.

To all whom it may concern:

Be it known that I, OLIN S. PROCTOR, a citizen of the United States of America, residing in the city and county of Denver and State of Colorado, have invented a new and useful Tunneling-Machine, of which the following is a specification.

My invention relates to improvements in tunneling machines.

The objects of the invention are: First, to provide a tunneling machine comprising a rotatable head carrying a plurality of drilling machines or engines operated by fluid under pressure, which are adapted to cut away the breast of the tunnel as the head revolves, means being employed for supporting the said head and for feeding the same forward against the tunnel breast as the drills cut away the surface of the same. Second, to provide a tunneling machine comprising a rotatable head carrying a plurality of drilling machines provided with drills or moils arranged in groups, and so positioned that the drills or moils in one group travel in a different area or circular path from those in the preceding group, the drills of each group radiating from a common point, and being set at an angle towards the direction of rotation of the head, means being provided for moving the machine against the breast of the tunnel, as the moils cut away the surface thereof, and for removing the muck or rock chippings continuously during the operation of the machine. And third, to provide means for conveying the exhaust when steam is used as the actuating fluid, from the tunneling machine out of the tunnel. These objects are accomplished by the mechanism illustrated in the accompanying drawings, in which:

Figure 1, is a side elevation of the improved tunneling machine as it appears when in operation, the moils being arranged in groups of six in number. Fig. 2, is a plan view of the machine partly broken away in places for the sake of clearer illustration. Fig. 3, is an enlarged, front elevation of the revoluble cutter head, showing the manner of disposing the moils in order that they shall operate upon the whole surface of the tunnel breast between the innermost and outermost moils, the moils in this instance being arranged in groups of five each. Fig. 4, is an enlarged, vertical, sectional view of the revoluble head, showing particularly the manner of convey-

ing the exhaust from the drilling machines. Fig. 5, is an enlarged, vertical, longitudinal, sectional view of the car by which the cutter head and its supporting carriage are propelled either forward or backward, the adjustable connection between the said car and carriage being clearly shown. Fig. 6, is a rear elevation of the revoluble cutter head and carriage, showing the openings through the end of the head, through which access may be had to the drilling machines (omitted), and also the openings through which the muck is discharged upon a chute attached to the carriage, by which it is conveyed to an endless carrying belt. Fig. 7, is a perspective view—slightly enlarged—of one of the bearing spools, that forms a part of the carriage steering and guiding mechanism of the car. Fig. 8, is an enlarged view of a cylindrical nut forming an element of the adjusting means. Fig. 9, is a vertical, sectional view of a pressure cylinder. And Fig. 10, is a plan view of the said cylinder.

Similar letters of reference refer to similar parts throughout the several views.

Referring to the accompanying drawings: The numeral 1, designates a carriage comprising an I beam 2, supported at its forward end by a pair of wheels 3, the axles of which are journaled in a bearing carried by a bracket 4, which is secured to the under side of the I beam. The tread of each wheel is beveled, as shown, to conform to the rotundity of the tunnel, and the treads are broad in order to support the weight upon them without cutting into the surface of the tunnel. A hollow shaft 5, is supported in bearings 6, secured to the upper side of the I beam, and upon the forward end of this shaft is rigidly mounted, in any suitable manner, a circular cutter head 7, which comprises a band or rim 8, supported by four spokes 9, which are formed integral with the band, and which are connected by an integral hub. The rear end of the head is closed by a plate 10, which is in the form substantially of the frustum of a cone, and comprises a flat, circular portion, and an outwardly flared portion, which is integrally connected to the rear edge of the band. The band, spokes, and end plate, constitute an integral structure, and gaps or recesses 11 are formed in the band, beginning at each spoke, and extending rearward to a point, about half the distance to the next spoke, thus dividing the rim into sections,

the terminal edges of which are at an incline. The spokes 9, are in the form of flat bars, which are turned edgewise to stand at an angle, or so that each spoke inclines from its rear edge toward the direction of rotation of the head, and from the hub they extend at right angles to the axis of the head, for about half their length, while the remaining portions extend back at an angle corresponding to the flared portion of the end plate 10.

Upon the rear side of each spoke, is secured a plurality of rock drilling machines, and these may be independent rock drilling engines, such as are in common use, or a single casting 12, may be employed, as illustrated, in which is formed the desired number of hammer piston cylinders, and one of these castings is securely bolted to each spoke of the head, a cushioning medium 13, being interposed between the casting and the spoke to absorb the jar occasioned by the contact of the cutting bits with the tunnel breast. By employing a single casting with a plurality of hammer piston cylinders, a great saving of time and expense is effected, as it is apparent that the casting can be more quickly and easily secured in position than could a plurality of independent drills. The cylinders are formed within the casting to radiate from a common point, and they are of the usual type, and are each provided with the usual fluid operated hammer piston. In place of the common type of drill bit, moils 14, such as illustrated, are preferably employed, and the outermostmoil in each group extends slightly beyond the periphery of the head, and these outer moils cut a circle slightly greater than the diameter of the head, so as to give clearance to the said head, and enable it to revolve freely.

The moils of one group are designed to revolve in circles or paths between those of another group, and thus the whole surface of the tunnel breast is acted upon, and as the moils of each group radiate from a common point, and also incline toward the direction of rotation of the head, the rock is given a slanting blow similar to that imparted by a manually operatedmoil, and the rock is more easily and effectively chipped away.

Fluid under pressure is admitted to each group of cylinders, through a common pipe 15, which communicates with the valve chambers 16, of each cylinder, and with the forward end of the hollow shaft 5, which shaft enters the hub of the head, and is provided with apertures 17 which register with similar apertures in the hub, into which the free end of the pipes 15 are secured. Fluid under pressure is admitted to the shaft 5, through a supply pipe 18, which connects with a source of supply, and with a nipple 19, in the rear end of the shaft 5, which has a fluid tight connection with the shaft, but such as to allow the shaft to turn independently of it. A

valve 20, at the end of the nipple, controls the entrance of the actuating fluid.

The exhaust fluid from the drilling cylinders escapes through pipes 21 and 21^A, which connect with the valve chambers 16, of the drilling cylinders, and with an annular chamber 22, on the rear of the head. This chamber is formed by a band gear wheel 23, which is rigidly secured to the end plate of the head, and a flanged disk 24, which extends partially into the band gear so as to close the chamber. This disk 24, has an axial hole through which the shaft 5, passes, and a suitable packing box 25 is formed on the disk to surround the shaft. A packing ring 26, also surrounds the periphery of the disk 24, where it enters the band gear, and the exhaust fluid is thus prevented from escaping either around the shaft or at the periphery of the disk. The disk is held stationary by being bolted either to the I beam, or the forward shaft bearing 6, and an outlet nipple 27 is formed upon the said disk, preferably in position to lie beneath the I beam, and to this nipple is secured one end of a hose 28, which extends rearward beneath the carriage and car, and conveys the exhaust without the tunnel. This arrangement is especially desirable and even essential, where steam is used in operating the machine.

The head is revolved in the following manner: In suitable bearings, supported upon brackets 29, secured to the I beam, is journaled a shaft 30, having a pinion 31, on its forward end in mesh with the band gear 23. A worm gear 32 is also secured upon this shaft, and meshes with a worm pinion 32^A, on the crank shaft 33, of a suitable engine 34, supported on brackets which are secured to the I beam. Actuating fluid is admitted to the engine through a pipe 35, which connects with the supply pipe 18, and which is provided with a valve 36, for regulating and cutting off the actuating fluid. The carriage and its cutter head are propelled by a power driven car or truck 37, which is connected to the carriage in such a manner as to permit of the lateral and vertical adjustment of the rear end of the said carriage, as will presently appear. The car 37, comprises heavy side castings 37^A, which are connected by cross bars, and which are mounted on flanged track wheels 38, adapted to run upon tracks 39, which are laid on bed timbers 40, the tracks and timbers being extended, as the machine advances. The side castings are formed with semi-circular bearing recesses 40^A, near their forward ends, in which are seated circular flanged blocks 40^B, which are held in the semi-circular slots, but so as to be capable of being turned therein, by strap irons 41, which lie between the flanges of the blocks and are bolted to the side castings. Each of these blocks is provided with a pair of diametrically opposite apertures 42, which

support a pair of rods 43 and 44 respectively, which connect the two blocks. The rod 43 may be rigidly connected to the two blocks, and has a finished surface, while the rod 44 is threaded between the two blocks and is arranged to turn freely in them, suitable means being employed to prevent longitudinal movement of the rod within the blocks. One end of this rod extends out beyond the adjacent block, and is provided with one or more transverse holes through which any suitable implement, such as a bar or rod, may be passed for the purpose of turning the rod. Upon these rods is mounted a circular nut 45 (see Fig. 8), having diametrically opposite apertures 46 and 47, one of which is smooth and receives the rod 43, and the other is threaded and receives the threaded rod 45. Thus, by turning the rod 44, in the manner above mentioned, the nut 45, is moved laterally thereon, being held against rotation by the rod 43, upon which it slides freely. Edgewise through the nut, and centrally between the apertures 46 and 47, is formed a threaded aperture 48, which receives a vertically disposed threaded rod 49, the extremities of which are smooth and are journaled in bearings 50, which are formed on or secured to vertically disposed angle bars 51, which are bolted to the rear end of the I beam 2. The upper end of the rod 49, extends beyond its bearing, and is provided with one or more transverse holes 52, in which a lever may be inserted to turn the said rod, and by turning this rod it is moved either up or down through the nut 45, thereby tilting the I beam 2, and changing the vertical angle of the cutter head.

The car 37, is propelled, and held against backward movement, while the machine is operating, in the following manner: A cog track 53, is laid upon the bed timbers, between the car tracks 39, and upon the rear axle of the car is rigidly mounted a gear wheel 54, which meshes with the cog track. On the same axle is also rigidly mounted a worm gear wheel 55, which is actuated by a worm pinion 56, on a shaft 57, suitably supported in bearings attached to the under side of the cross bars of the car. A worm gear 58 is also rigidly mounted on the shaft 57, and is actuated by a worm pinion 59, on a shaft 60, mounted in bearings 61, secured to the car.

Upon the inner end of the shaft 60, is mounted a beveled gear wheel 62, which is actuated by a similar beveled gear 63, on a shaft 64, mounted in bearings 65 upon the car. The shaft 64 has a feather 66 extending a portion of its length, and upon the feathered portion is mounted a friction wheel 67, which is moved back or forth upon the shaft by a yoke-shaped follower block 68, which is mounted on a threaded shaft 69, journaled in the upper ends of the bearings 65. The shaft 69, is

provided at one end, with a crank handle 70, and when the shaft is turned thereby the follower block will be moved either forward or backward, carrying with it the friction wheel 67, which is engaged by the yoked portion of the said follower block. The friction wheel 67, is actuated by a friction disk 71, on the crank shaft 72, of a suitable engine 73, which is supplied with actuating fluid through a flexible pipe 74, connecting with the general supply pipe 18. The pipe 74 is provided with a cut off valve 75, as shown.

It will be apparent that when the wheel 67 is on one side of the axial center of the disk 71, and engaged thereby, it will be turned in one direction, and that when it is on the opposite side of the axial center of the disk and engaged thereby, it will be turned in the opposite direction, and that contact with the disk adjacent to its periphery imparts to the wheel the highest degree of speed relatively to the diameter of the disk, while the speed of the wheel is gradually diminished as it approaches the axial center of the disk. Thus, by contact of the disk 71 with the wheel 67, motion is imparted to the car through the train of bevel and worm gearing, which turns the gear 54 in mesh with the cog track. The speed as well as the direction of movement of the car is determined by the proper manipulation of the shaft 69, and consequent movement of the friction wheel 67.

The end plate 10, of the revoluble head 7, is provided with openings 76, adjacent to the rear ends of the drilling engine castings 12, through which access may be had to the said castings from the rear of the head. These openings permit the removal of a casting for any purpose, when the machine is in the tunnel, thereby avoiding the necessity of backing the machine out. The end plate 10, is also provided with openings 77, which occur about midway of the length of the spokes, and at their forward sides, and through these openings the rock chippings or muck is discharged, as the head revolves. Plates 78 are secured to the spokes of the head to project at right angles therefrom, and these plates are positioned at the inner edges of the discharge openings 77, and their function is to receive the muck as it slides down the spokes, and guide it through the discharge openings 77, whence it falls upon a chute 79, which is attached to the carriage (see Fig. 6), which delivers it upon an endless belt 80, of any preferred type, the forward end of which lies beneath the said chute. The belt 80, is mounted on suitably drums or sprocket wheels, as the case may be, according to the style of belt. As illustrated, a drum 81, on a shaft 82, suitably secured to the I beam, supports the belt at the forward end of the carriage, and a sprocket drum 83, on a shaft 84, supported in brackets attached to the car, supports the belt at its rear end. The shaft 84,

also carries a sprocket wheel 85, which is connected by a chain 86, with a sprocket wheel 87, on the crank shaft 72, of the rear engine 73, and thus the belt is operated to carry away the muck as it falls from the chute 79. A car 88, receives the muck as it falls from the belt, and this car rests upon a platform 89, which rests upon the tracks 39, and which is attached to the main propelling car, so that it with the car may always stand beneath the discharge end of the belt, as the machine moves forward.

The recesses 11, in the band portion of the head, occur at the outer ends of the drilling engine castings 12, and the band or rim sections, formed by the recesses 11, serve as scrapers which gather up the muck, as the head revolves. In order to steady the cutter head, and prevent twisting of the carriage during the operation of the machine, I support a pressure cylinder 90 in any suitable manner on the forward end of the carriage. This cylinder is provided with a piston 91 on the lower end of a piston rod 92, which is preferably rectangular in cross section, and extends out through a similarly shaped aperture in the upper cylinder head 93. This cylinder head is formed with diagonally opposite concentric slots 94, through which bolts or cap screws 95 are inserted and screwed into lugs formed on the upper end of the cylinder 90. By loosening these bolts, the cylinder head 93 may be turned axially, which movement of the head also turns the piston rod 92, and when the bolts 95 are screwed down, the head 93 and piston rod are held against axial movement. Upon the upper end of this piston rod is mounted a pair of wheels or rollers 96, which are designed to contact with the top of the tunnel, and from the lower end of the cylinder 90, a pipe 97 extends to the main supply pipe 18. This pipe 97, is provided with an ordinary three way valve 98, which when properly manipulated admits actuating fluid to the cylinder 90, below the piston 91, whereby the wheels 96 are forced against the top of the tunnel, and by turning the valve to another position the supply is cut off between the valve and pipe 18, and the fluid exhausts from the cylinder, allowing the piston to drop. Should the carriage have a tendency to work to one side, owing to the excessive weight upon the side of the cutter head which gathers the muck, it is only necessary to set the wheels 96 at a slight opposing angle to the direction in which the carriage is being moved, and this tendency on the part of the carriage will be overcome, and it will move forward without swerving from a true course.

The operation of the improved tunneling machine is as follows: The bed timbers 40, and tracks 39, having been laid, as well as the cog track 53, the machine is assembled

and placed upon the tracks, as illustrated in Fig. 1. Actuating fluid is admitted to the rear engine 73, which operates the friction disk 71, and thereby communicates motion to the gear wheel 54, in mesh with the cog track 53, as follows: The disk 71, actuates the friction wheel 67, and shaft C 4, by which the beveled gear 63 on said shaft is turned. The beveled gear 63, actuates a similar beveled gear 62, on the shaft 60, upon which is also mounted a worm pinion 59 in mesh with a worm gear 58, on a shaft 57, and this shaft carries a worm pinion 56, which actuates a worm gear 55, on the rear axle of the car 37, and this axle carries the gear 54, in mesh with the cog track. In this manner the machine is moved against the rock breast to be operated upon, and the valve 20 is opened, admitting air to the hollow shaft 5, whence it passes through the outlets 17, in the ends of the shaft, and through the several supply pipes 15, to the cylinders of the drilling engines. At the same time, air is admitted to the forward engine 34, the crank shaft 33 of which carries the worm pinion 32^A, in mesh with the worm gear 32, on shaft 30, which shaft also carries the pinion 31, which actuates the band gear 23, and thereby revolves the head. As the head revolves, the moils act upon the rock, chipping its surface away in a manner similar to the action of a manually operated drill ormoil, as all the moils incline toward the direction of the rotation of the head, and the moils of each group radiate with respect to each other. By delivering a slanting blow, as accomplished by the inclination of the drilling engines, the rock is more easily and effectually chipped away, and the arrangement of the groups of moils causes the whole area of rock within the radius of the moils to be acted upon.

The band sections of the head scrape up the muck as it falls to the bottom of the tunnel, and from the head it discharges through the openings 77 onto the belt 80, which delivers it to the car 88. The threaded rods 44 and 49, are operated to give the desired inclination to the head, which is steadied and held in a true course by the contact of the wheels 96 with the top of the tunnel.

Some of the elements of this invention are shown in my pending application for improvements in tunneling machines Serial Number 359,533, filed February 26, 1907, said prior application disclosing the supporting main and supplementary frames consisting of the beam and the track-wheeled frame and the adjustable joint between the two, together with the rotary cutter head, provided with a plurality of independent drilling engines and a muck moving conveyer.

Having described the invention, what I claim as new and desire to secure by Letters Patent, is:

1. In a tunneling machine, a supporting

carriage, a circular head carrying a plurality of independent drilling machines, and means for rotating said head; a power driven car; an adjustable connection between the head and
5 car; and a conveyer supported on said car and connected to said carriage and arranged to receive muck from said head and adapted to convey the muck from said head to the rear of the machine as it advances.

10 2. In a tunneling machine, a circular head; a plurality of drilling machines in the head provided with moils which are set at an angle to the axis of the head; a power driven car; a carriage supporting the head; adjustable
15 means connecting the carriage and car; and means connected with the carriage and car for removing the muck as the machine advances.

20 3. In a tunneling machine, a rotatable head, comprising a circular band, and a plurality of spokes which incline edgewise toward the direction of rotation of the head; a plurality of drilling machines on each of said
25 spokes, provided with moils which incline in accordance with the incline of the spokes, the moils on each spoke also radiating from a common point; a hollow shaft upon which said head is mounted, connected with a source
30 of fluid under pressure; a carriage upon which the shaft is mounted; and means for adjusting the rear end of the carriage both vertically and horizontally; supply pipes connecting the hollow shaft with the drilling machines; means for rotating the head; and
35 means connected with the machine for removing the muck as the machine advances.

40 4. In a tunneling machine, the combination with a carriage, which is laterally and vertically adjustable at its rear end, of a hollow shaft mounted on said carriage, connected with a source of fluid under pressure; a rotatable head on the shaft, comprising a band and spokes and a hub in which the said
45 shaft is secured; a gear wheel on the head; a power driven pinion in mesh with said gear wheel, for turning the head; a group of fluid actuated drilling engines on each spoke, each of said groups being inclined towards the direction of rotation of the head, while the engines of each group radiate from a common
50 point, and are provided with moils; supply pipes connecting the engines of each group with the hollow shaft; pipes for conveying the exhaust from the engines; and means connected with the machine for removing the
55 muck as the machine advances.

60 5. In a tunneling machine, the combination with a carriage, laterally and vertically adjustable at its rear end, of a hollow shaft mounted on the carriage, which is connected at one end with a source of fluid under pressure; a rotatable head on the shaft, comprising a band, and a plurality of spokes, which are inclined edgewise, toward the direction
65 of rotation of the head; a group of fluid op-

erated rock drilling engines, on each of said spokes, which incline in accordance with the spokes, the engines of each group radiating from a common point, and being provided with moils; supply pipes connecting the en- 70 gines of each group with the hollow shaft, and pipes for conveying the exhaust from said engines; a gear wheel on the head; a pinion in mesh with the gear wheel; and an engine on the carriage connected with a source of power for operating the pinion to turn the head; and a power driven endless belt on the carriage, operating in connection with the head, for removing the muck as the machine
75 advances.

80 6. In a tunneling machine, the combination with a carriage, laterally and vertically adjustable at its rear end, of a hollow shaft mounted on the carriage, which is connected at one end with a source of fluid under pres- 85 sure; a circular cutter head mounted on the shaft, having a plurality of groups of fluid actuated drilling engines connected with the hollow shaft, the engines of each group being arranged at an angle towards the direction 90 of rotation of the head, and being provided with moils; an end plate closing the rear of the cutter head, having openings in line with the rear ends of the drilling engines, and openings for the discharge of muck; means 95 for rotating the head; means whereby the muck is gathered and discharged through the said discharge openings as the head revolves; and an endless conveyer supported by the carriage for receiving the muck. 100

7. In a tunneling machine, the combination of a power operated car; a carriage adjustably connected at its rear end to said car; a hollow shaft on said carriage, connected at one end with a source of fluid under pres- 105 sure; a circular rotatable cutter head on the shaft, having a plurality of fluid operated drilling engines, connected with the hollow shaft and provided with moils, said engines being arranged in groups which incline to- 110 ward the direction of rotation of the head; a diaphragm on the rear end of the cutter head having discharge openings; means whereby the muck is collected and discharged through said openings as the head rotates; and a 115 power driven endless conveyer supported by said car and carriage for catching and conveying away the muck as it discharges from the cutter head.

8. In a tunneling machine, the combina- 120 tion with a power driven car; a carriage having a shaft journaled thereon provided with a rotatable cutter head; of an adjustable coupling for connecting the car and carriage, comprising a pair of oppositely disposed cir- 125 cular blocks pivotally mounted in the sides of the car; a pair of rods extending from one block to the other, and mounted therein, one of said rods being threaded on the portion of its surface lying between the blocks, and hav- 130

ing an extended end adapted to receive a lever; a circular nut mounted upon the said rods, having a threaded aperture through which the threaded rod passes, and an un-
 5 threaded aperture through which the un-
 threaded rod passes, and a threaded aperture
 extending through the nut between the other
 two openings and at right angles to them; a
 10 threaded rod in the last mentioned aperture;
 and standards secured to the rear end of the
 carriage, having boxes in which the ends of
 the said threaded rod are pivotally mount-
 ed, one of said ends being extended to re-
 ceive a lever.

15 9. In a tunneling machine, the combina-
 tion with a carriage having a rotatable power
 driven cutter head mounted thereon, and a
 power driven car; of means for adjustably
 connecting the rear end of the carriage with
 20 the car, comprising a pair of oppositely dis-
 posed circular flanged blocks pivotally
 mounted in semi-circular recesses in the sides
 of the car; and means for securing them with-
 in the recesses; a smooth rod and a threaded
 25 rod uniting the blocks, the threaded rod be-
 ing extended beyond one of the blocks and
 provided with lever receiving apertures; a
 nut mounted on the two rods, and provided
 with a smooth and with a threaded aperture
 30 to receive the respective rods, and with a
 vertically disposed threaded aperture ex-
 tending between the other two apertures; a
 threaded rod extending through the vertical
 aperture; standards on the rear end of the
 35 carriage, having bearings in which the ends
 of the said rod are journaled, one of said
 ends being provided with lever-receiving
 apertures; and means connected with the
 car and carriage for removing the muck as
 40 the car advances.

10. In a tunneling machine, the combina-
 tion with a power driven car, of a carriage
 adjustably connected at its rear end to said
 45 car; a hollow shaft mounted on the carriage,
 and connected at one end with a source of
 actuating fluid; a rotatable head mounted on
 said shaft, having a plurality of groups of
 fluid operated drilling engines connected
 50 with said shaft, the engines of each group
 being radially disposed while the groups in-
 cline towards the direction of rotation of the
 head; a gear wheel on the head; a shaft hav-
 ing a pinion in mesh with the gear wheel; a
 worm gear on said shaft; a crank shaft hav-
 55 ing a worm pinion in mesh with the worm
 gear; an engine on said carriage connected
 with a source of actuating fluid, for operating
 said crank shaft; and means connected with
 the machine for collecting and discharging
 60 the muck as the machine advances.

11. In a tunneling machine, the combina-
 tion with a carriage, of a hollow shaft
 mounted thereon, connected with a source
 of actuating fluid; a rotatable head mounted
 65 on the shaft, having a plurality of groups of

fluid operated drilling engines connected
 with the hollow shaft; a gear wheel on the
 head; an engine on the carriage, connected
 with a source of actuating fluid; a crank shaft
 operated by said engine having a pinion; a
 70 system of gears connecting the pinion and the
 gear wheel on the head; a power driven car,
 adjustably connected to the rear end of the
 carriage; and means connected with the ma-
 75 chine for automatically collecting and dis-
 charging the muck as the machine advances.

12. In a tunneling machine, a carriage
 having a hollow shaft mounted thereon, con-
 nected with a source of actuating fluid; a ro-
 tatable head mounted on the shaft, compris-
 80 ing a hub portion provided with a plurality
 of spokes, a plurality of radially disposed
 fluid actuated drilling engines on the rear
 side of each spoke, and a cushioning medium
 interposed between the said engines and
 85 spokes, the engines being connected with the
 hollow shaft.

13. In a tunneling machine, the combina-
 tion with a power driven car, and a carriage
 adjustably attached at its rear end to said
 90 car; of a hollow shaft mounted on the car-
 riage and connected with a source of actu-
 ating fluid; a circular head mounted on the
 shaft, having a rim divided by gaps or re-
 cesses into shovel sections; spokes attached
 95 to the shovel sections and uniting in a hub
 which receives the end of the hollow shaft;
 an end plate on the rear of the head having
 discharge openings on a plane with the
 spokes; fluid actuated drilling engines con-
 100 nected with the hollow shaft, and arranged
 in radial form on said spokes; a chute on the
 carriage in the radius of the discharge open-
 ings; a power driven conveyer beneath the
 chute; and means for rotating the head. 105

14. In a tunneling machine, the combina-
 tion with a rotatable power driven circular
 head, having a rim divided by gaps or re-
 cesses into shovel sections; spokes attached
 110 to the shovel sections and uniting to form a
 central hub; a carriage; a hollow shaft
 mounted on the carriage, one end of which is
 connected with a source of fluid under pres-
 sure, while the other end enters the hub of
 the head and supports the same; a group of
 115 fluid actuated drilling machines secured upon
 each spoke at an angle of inclination toward
 the direction of rotation of the wheel, the en-
 gines of each group being radially disposed
 and connected with the hollow shaft; an end
 120 plate on the rear of the head, having dis-
 charge openings; and a chute on the carriage
 projecting into the path of the discharge
 openings; of a car connected to the rear end
 of the carriage by an adjustable connection;
 125 and means for propelling the car; and a
 power driven endless conveyer supported at
 one end by the carriage so as to lie beneath
 the chute and at the opposite end by the car.

15. In a tunneling machine, the combina- 130

tion with a carriage, and means for propelling the same; of a hollow shaft mounted on the carriage connected at one end with a source of actuating fluid; a rotatable head 5 mounted on the other end of the shaft, having a plurality of groups of fluid actuated drilling machines inclined at varying angles and connected by pipes with the interior of the hollow shaft; a band gear wheel on the 10 rear of the head; a power driven pinion in mesh with said gear; a stationary circular flanged plate mounted axially on the hollow shaft, which projects into the band gear and closes its rear end to form a chamber in said 15 gear; packing boxes around the axial hole of the plate and around its periphery; exhaust pipes leading from the said engines, and connecting with the chamber in the gear; an outlet pipe connecting with the chamber through 20 the stationary plate, and leading away from the machine; and means connected with the head whereby the muck is collected and conveyed away as the machine advances.

16. A rotary tunneling machine, comprising a revoluble cutter head; a supporting 25 beam for said cutter head; an abutment car or truck for said cutter head, and its support-

ing beam; and a universal joint connecting said cutter head and its supporting beam to said car, said connecting joint being arranged 30 to permit any desired degree of inclination to be given to said beam and cutter head relative to the longitudinal axis of said car.

17. A rotary tunneling machine, comprising a revoluble cutter head; a supporting 35 beam for said cutter head; an abutment car or truck for said cutter head, and its supporting beam; a universal joint connecting said cutter head and its supporting beam to said car, said connecting joint being arranged to 40 permit any desired degree of inclination to be given to said beam and cutter head relative to the longitudinal axis of said car; and diametrically arranged radial adjustable 45 roller abutment supports on said beam adjacent to said cutter head for supporting said cutter head in predetermined positions relative to the longitudinal axis of said car.

In testimony whereof I affix my signature in presence of two witnesses.

OLIN S. PROCTOR.

Witnesses:

G. SARGENT ELLIOTT,
ADELLA M. FOWLE.