

No. 896,563.

PATENTED AUG. 18, 1908.

O. R. MILLER.
WASHING MACHINE.
APPLICATION FILED SEPT. 28, 1907.

2 SHEETS—SHEET 1.

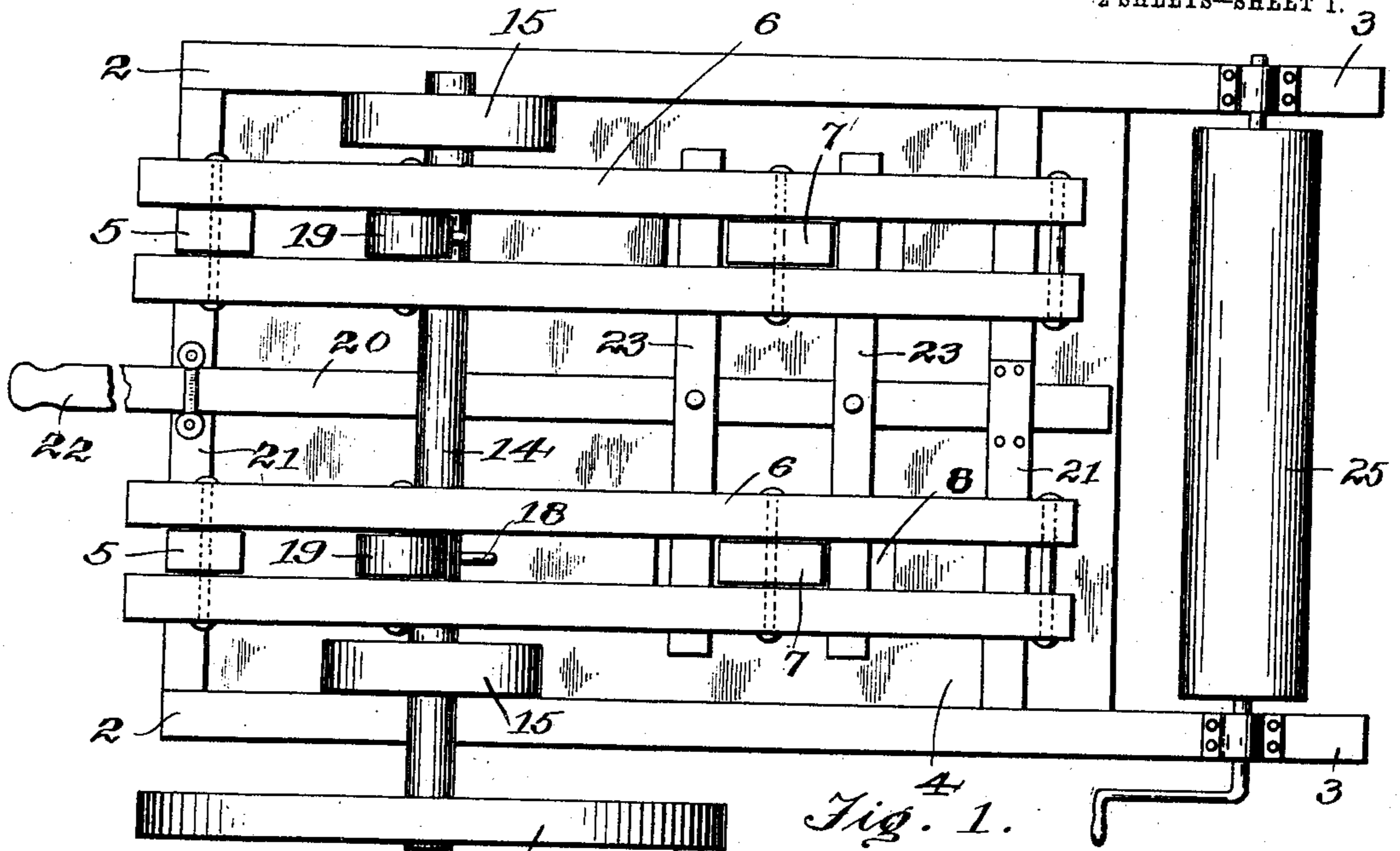

Fig. 1.

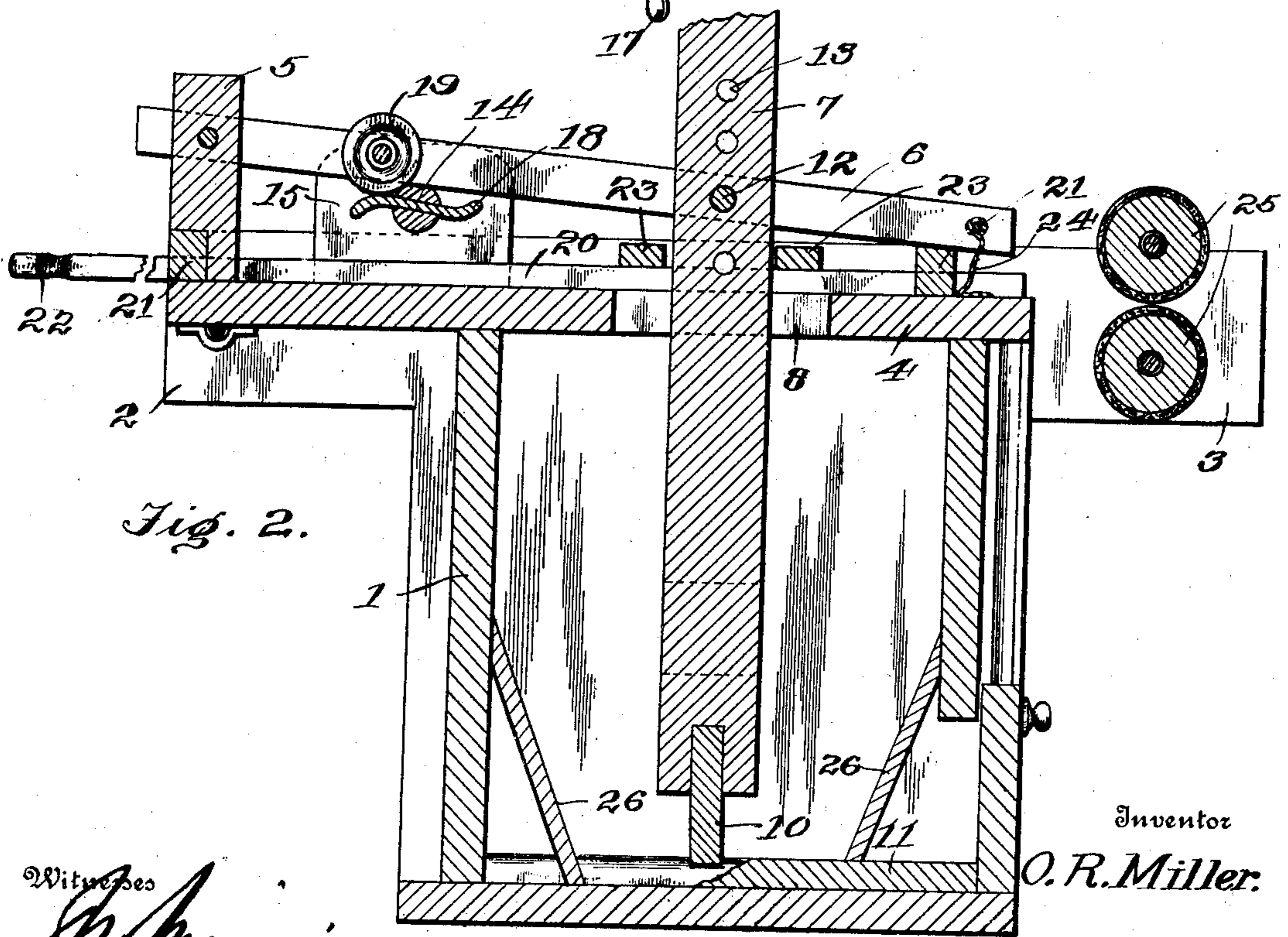

Fig. 2.

Inventor
O. R. Miller.

Witnesses

Johnnie W. Woodson

By

Ph. M. Macy, Attorneys

No. 896,563.

PATENTED AUG. 18, 1908.

O. R. MILLER.
WASHING MACHINE.
APPLICATION FILED SEPT. 28, 1907.

2 SHEETS—SHEET 2.

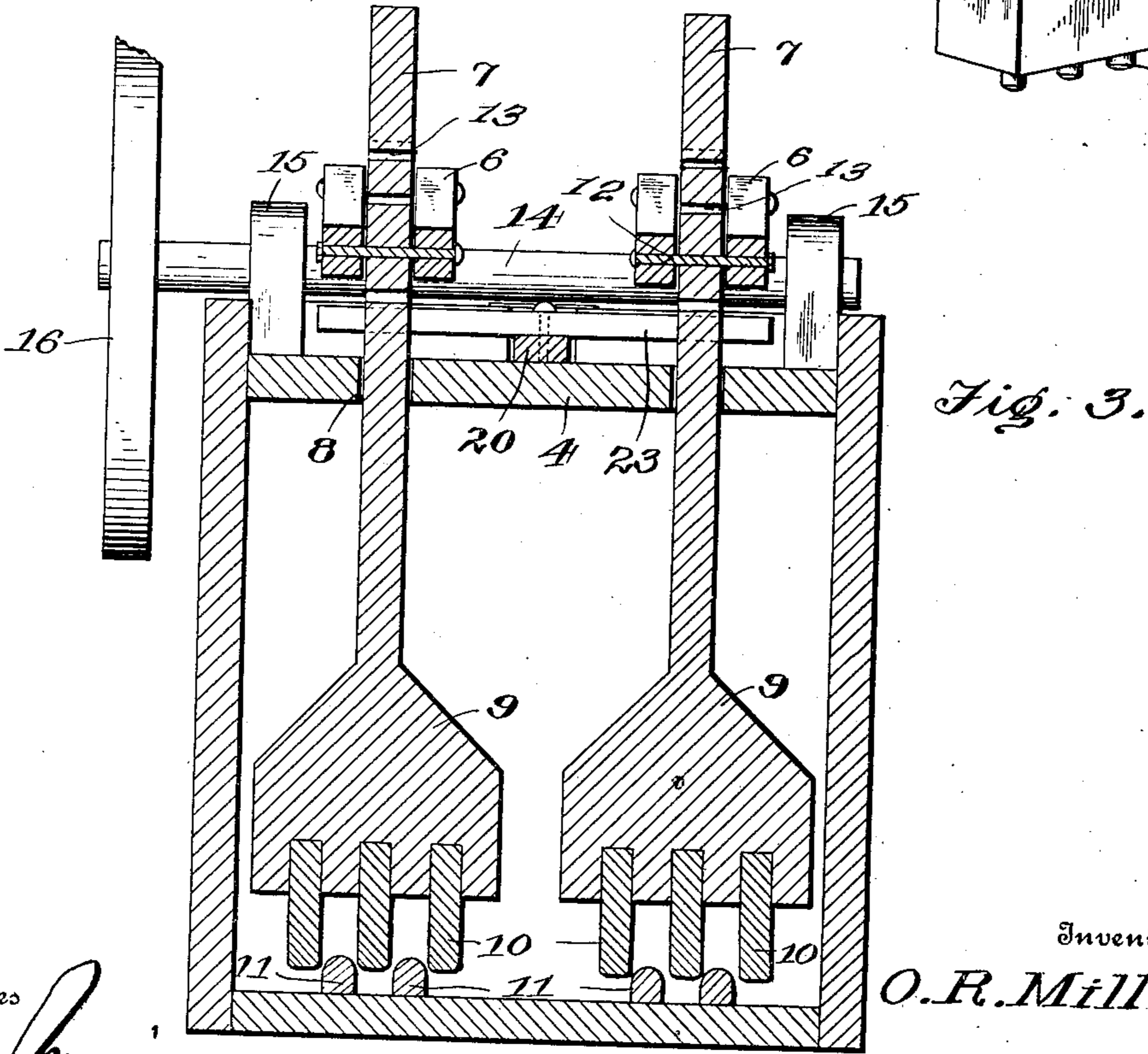
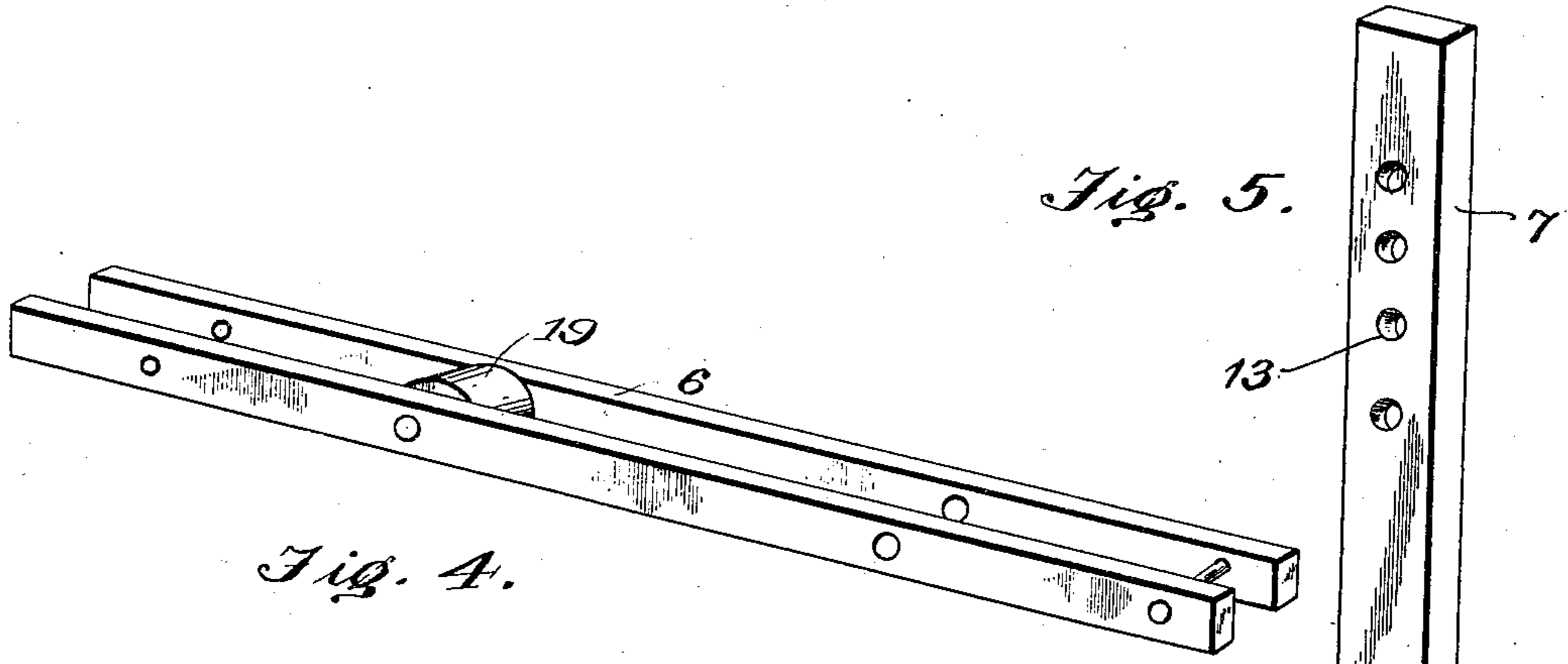

Inventor
O. R. Miller.

Witnesses
J. Miller
W. A. Woodson

By
R. A. Bailey, Attorneys

UNITED STATES PATENT OFFICE.

OTTO R. MILLER, OF ESBON, KANSAS.

WASHING-MACHINE.

No. 896,563.

Specification of Letters Patent.

Patented Aug. 18, 1908.

Application filed September 28, 1907. Serial No. 395,013.

To all whom it may concern:

Be it known that I, OTTO R. MILLER, citizen of the United States, residing at Esbon, in the county of Jewell and State of Kansas, have invented certain new and useful Improvements in Washing-Machines, of which the following is a specification.

The present invention is in the nature of an improved washing machine and aims to provide a device of this character embodying a novel construction whereby any clothes placed within the machine can be quickly and thoroughly cleansed.

A further object of the invention is to design a washing machine which can be readily manipulated by a single person and operates uniformly throughout the entire interior of the machine.

For a full description of the invention and the merits thereof and also to acquire a knowledge of the details of construction and the means for effecting the result, reference is to be had to the following description and accompanying drawings, in which:

Figure 1 is a top plan view of a washing machine embodying the invention. Fig. 2 is a longitudinal sectional view through the same. Fig. 3 is a transverse sectional view through the same. Fig. 4 is a detail view of one of the operating levers. Fig. 5 is a similar view of one of the plungers.

Corresponding and like parts are referred to in the following description and indicated in all the views of the drawings by the same reference characters.

The reservoir constituting the body portion of the machine and indicated at 1 is shown as rectangular in formation, the opposite sides of the reservoir being provided at their upper portions with two pair of projections 2—2 and 3—3. The cover 4 for the reservoir or tub 1 is pivotally mounted between the projections 2—2 and is designed to be swung upwardly to permit ready access to be had to the interior of the machine. A pair of standards 5 project upwardly from the hinged end of the cover 4 and have the levers 6 pivotally mounted thereon, the said levers extending along the cover 4 toward the swinging end thereof. In the present instance it will be observed that each of the levers 6 comprises a pair of spaced strips receiving the standards 5 between the same. Pivotaly connected to the levers 6 are the plungers 7 which extend through slots 8 in the cover 4 and project within the tub 1 ad-

acent the bottom thereof. The head 9 of each of the plungers 7 is laterally enlarged and is provided at its extremity with the teeth 10 received between longitudinal ribs 11 upon the tub body and moving between the said ribs as the plungers are swung back and forth upon their pivotal connection with the levers 6.

In the preferred embodiment of the invention the plungers 7 have their upper ends received between the spaced strips constituting the levers 6 and are adjustably connected thereto by means of the pins or bolts 12 passing through any one of a selected number of openings 13 in the said plungers. A transverse shaft 14 is journaled upon bearings 15 projecting from the cover 4, one end of the said shaft extending beyond the body portion of the machine and having a fly wheel 16 keyed thereon, the said fly wheel being provided with the usual handle 17. The portion of the shaft 14 under each of the levers 6 is provided with the oppositely extending lateral arms 18 designed to engage rollers 19 mounted upon the levers. It will thus be apparent that as the shaft 14 is rotated the lateral arms 18 will successively engage the rollers 19 so as to swing the levers 6 upwardly and then drop the same. In this manner a reciprocating movement is imparted to the plungers 7 and the lateral arms 18 for operating the two levers are preferably arranged alternately so that one plunger will be lifted while the opposite plunger is being dropped. For the purpose of swinging the plungers 7 upon their pivotal connection with the levers 6 so as to cause the same to operate in an effective manner throughout the entire interior of the tub 1, a slide bar 20 is mounted upon the cover 4, the said slide bar being guided in its movements by transverse strips 21 secured to the opposite ends of the cover. One end of the slide bar 20 extends beyond the cover and terminates in a handle 22, while cross bars 23 are applied to the slide so as to embrace the plungers 7. With this construction it will be obvious that by manipulating the slide bar 20 the plungers 7 can be swung back and forth within the interior of the tub so as to cooperate in an effective manner with the entire surface of the bottom thereof. In the present instance the swinging ends of the levers 6 are shown as connected to one of the transverse strips 21 by means of the cords or flexible members 24, the said cords serving to limit the out-

ward swinging movement of the levers. A pair of wringer rollers 25 are shown as journaled between the opposite set of projections 3—3 of the tub 1 and these rollers are preferably covered with canvas since the same is found to be equally as good as rubber and much more durable in use.

In the operation of the washing machine the cover 4 is swung upwardly to permit the clothes to be placed within the tub 1. The cover is then moved into normal position and the transverse shaft 14 rotated through the medium of the fly wheel 16 and handle 17. This rotation of the shaft alternately swings the two levers 6 upward and then permits the same to drop and thereby imparts a reciprocating movement to the pounders. At the same time the pounders can be swung upon their pivotal connection with the levers 6 through the medium of the slide 20 and the pounders thereby caused to cooperate effectively with the entire surface of the bottom of the tub.

If found desirable as shown in Fig. 2 boards 26 may be applied to the opposite corners of the body portion 1 of the machine for the purpose of preventing the clothes from lodging in the corners where they can not be acted upon effectively by the pounders. It may also be mentioned that the rollers 25 are designed to be employed either as a wringer, or as a mangle when dry to save the ironing of towels and the like.

Having thus described the invention, what is claimed as new is:

1. In a washing machine, the combination of a body portion, a pounder operating within the body portion, a lever having a pivotal connection with the pounder, a shaft journaled under the lever and provided with means for swinging the same to reciprocate the pounder, and a slide loosely engaging the pounder for swinging the same about its pivotal connection with the lever.

2. In a washing machine, the combination of a body portion, a cover therefor, a swinging lever mounted upon the cover, a pounder operating within the body portion and connected to the lever, means upon the cover for swinging the lever to reciprocate the pounder, and a slide mounted upon the cover and loosely engaging the pounder for swinging the same laterally within the body portion.

3. In a washing machine, the combination of a body portion, a cover therefor, a plurality of levers pivotally mounted upon the cover, a plurality of pounders operating within the body portion and having a pivotal connection with the respective levers, means cooperating with the levers to reciprocate the pounders, a slide mounted upon the cover, and cross bars applied to the slide and engaging the pounders to swing the same about their pivotal connection with the levers.

In testimony whereof I affix my signature in presence of two witnesses.

OTTO R. MILLER. [L. S.]

Witnesses:

W. H. LOOMIS,
E. C. HOFFHINES.