

No. 870,789.

PATENTED NOV. 12, 1907.

P. W. LYON.  
ORDER BLANK HOLDER.  
APPLICATION FILED JUNE 17, 1907.

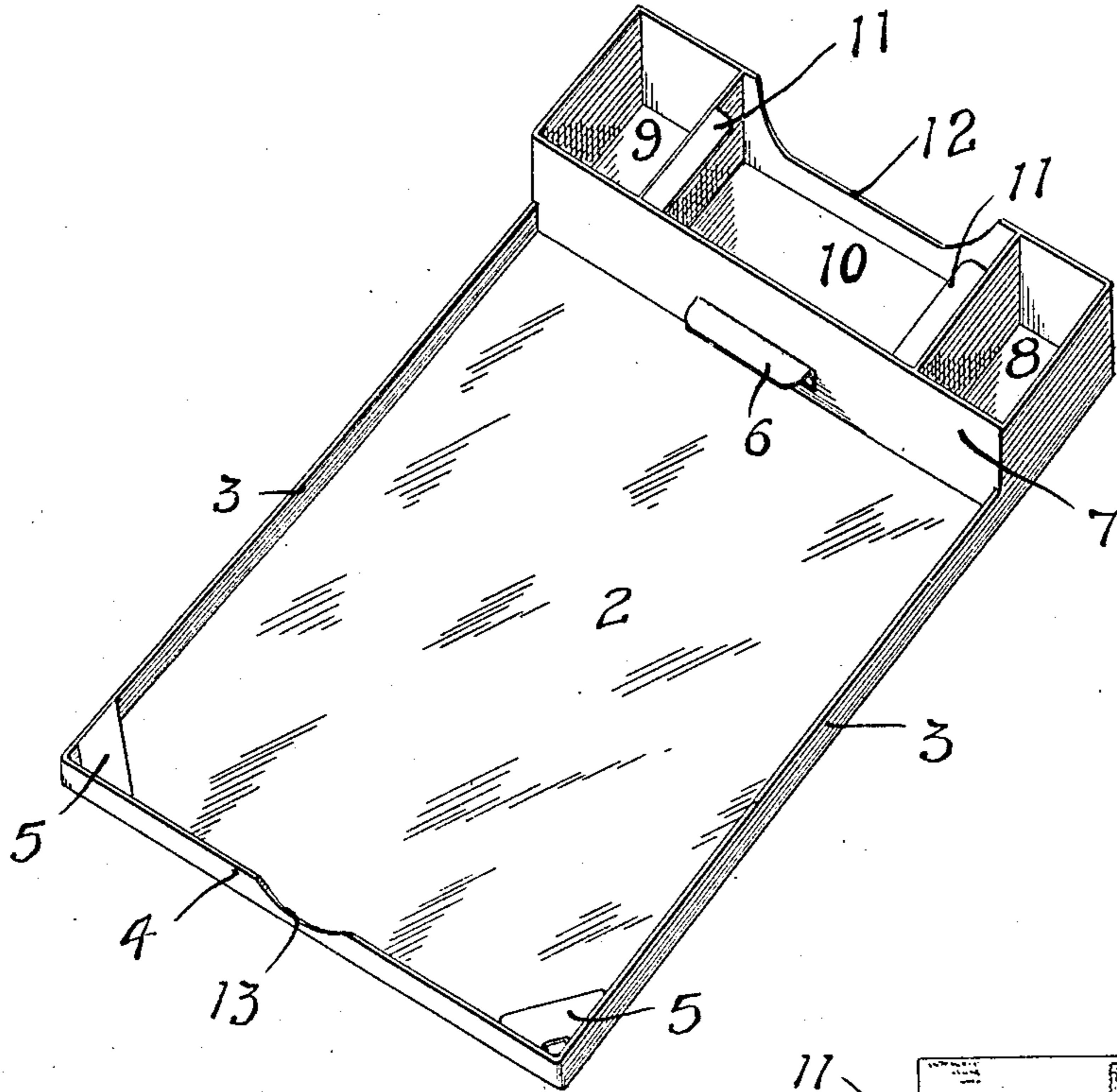

Fig 1.

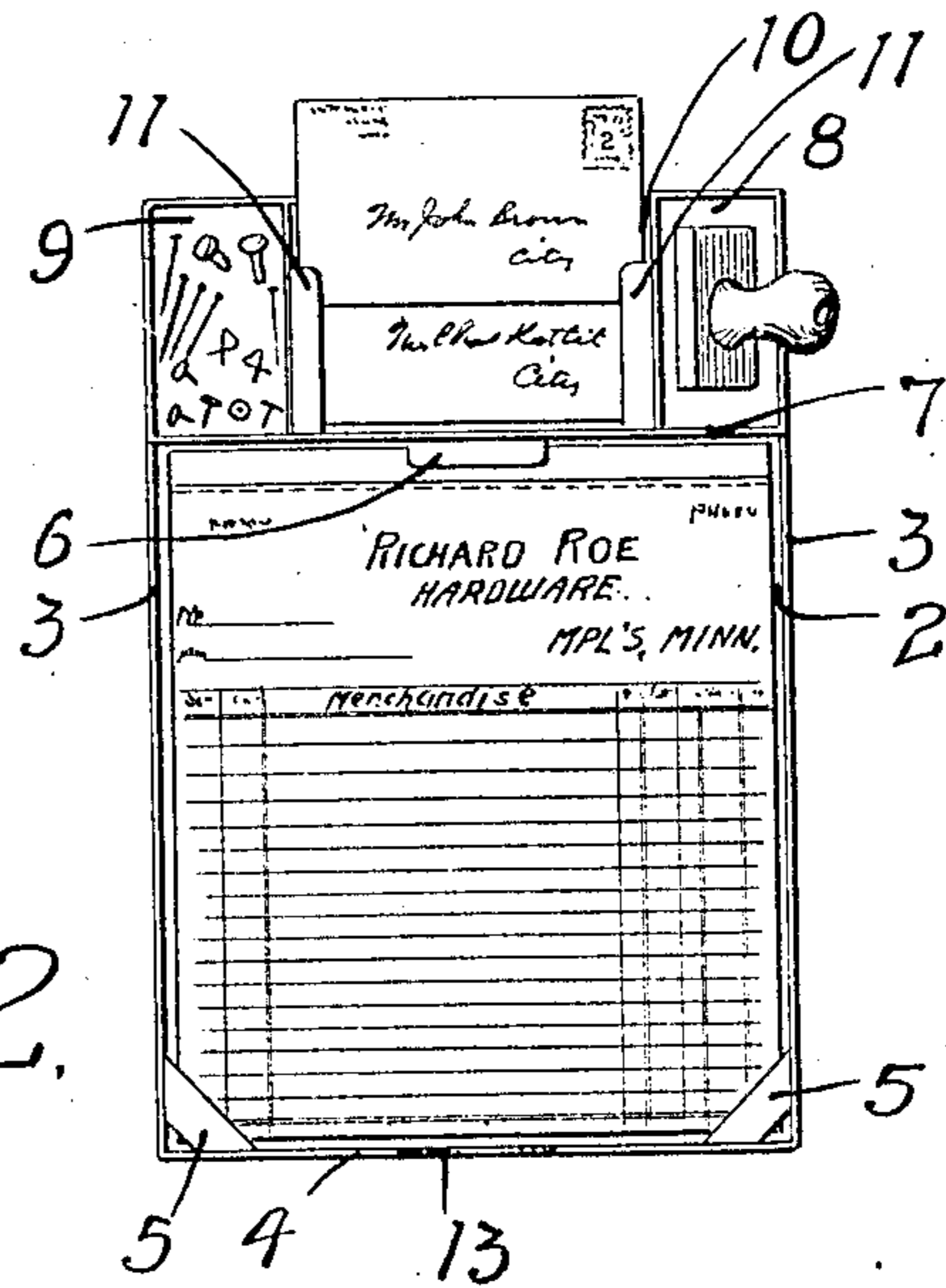

Fig 2.

WITNESSES  
*M. Walstrom*  
*J. B. Era.*

INVENTOR  
PLATT W. LYON  
BY *Paul & Paul*  
HIS ATTORNEYS

# UNITED STATES PATENT OFFICE.

PLATT W. LYON, OF MINNEAPOLIS, MINNESOTA.

## ORDER-BLANK HOLDER.

No. 870,789.

Specification of Letters Patent.

Patented Nov. 12, 1907.

Application filed June 17, 1907. Serial No. 379,413.

*To all whom it may concern:*

Be it known that I, PLATT W. LYON, of Minneapolis, Hennepin county, Minnesota, have invented certain new and useful Improvements in Order-Blank Holders, of which the following is a specification.

The object of my invention is to provide a device adapted to hold order blanks and envelopes for mailing the same, to the end that orders may be conveniently written and despatched with but little labor and without waste of time.

The invention consists generally in various constructions and combinations, all as hereinafter described and particularly pointed out in the claims.

In the accompanying drawings, forming part of this specification, Figure 1 is a perspective view of an order blank holder embodying my invention. Fig. 2 is a plan view of the same.

In the drawing, 2 represents the back of the holder having side flanges 3 and an end flange 4 with corner plates 5 connecting the side and end flanges and under which the corners of the pad of blanks are placed. A lip 6 is provided at one end of the holder on a cross-wall 7 and is adapted to overhang the end of the pad. The wall 7 incloses a rectangular space divided into pockets 8 and 9 which may be utilized for postage or other stamps, pins or paper fasteners and a centrally arranged pocket 10 having flanges 11 on the walls thereof under which a bunch of envelopes may be kept within convenient reach of the person using the holder. A recess 12 is provided in the outer portion of the wall opposite the wall 7 for convenience in inserting the bunch of envelopes in the holder or removing them one at a time. A recess 13 is also formed in the flange 4 to permit convenient access to the lower edge of the pad.

As indicated in Fig. 2, the order blanks are slipped into the holder under the corner plates 5 and the lip 6 and will be held thereby while the clerk or salesman is making out the order. The top blank may be conveniently removed from the holder and the envelopes addressed and the order mailed.

I prefer to make the holder of sheet metal as it will be less bulky made in that way and the back will be sufficiently rigid to render the device suitable as a support in writing on the blanks. The back will also be stiffened by the flanges or walls extending around the edges thereof. The holder may be made in different sizes according to the various sizes of blanks used.

I claim as my invention:

1. An order blank holder comprising a flat back plate, side flanges mounted on the longitudinal edges of said plate, an end flange connecting said side flanges at one end of said plate, a wall connecting said side flanges near the opposite end of said plate, the space between said flanges on said plate being adapted to receive order blanks, corner plates provided at one end of said holder and between which corner plates and said bottom plate the corners of the blanks are slipped, and means on said wall for overhanging the opposite ends of the blanks, substantially as described.

2. An order blank holder comprising a back plate having side and end flanges thereon between which the order blanks are placed, an envelop receptacle provided at one end of said holder and having parallel walls extending transversely of said holder and cross walls between which and said parallel walls the envelopes are held, and flanges provided on said cross walls and adapted to overhang the bunch of envelopes, substantially as described.

3. An order blank holder comprising a back plate and side and end flanges therefor, plates provided at the corners of said flanges and between which and said bottom plate the blanks are held, walls extending transversely of said back plate, a flange mounted on one of said walls and adapted to overhang the end of the blank, cross walls connecting said first named walls and forming therewith a series of compartments, one of said compartments being adapted to contain envelopes, and flanges mounted on said cross walls and arranged to overhang the envelopes in said compartment.

4. An order blank holder comprising a back plate, side and end flanges provided on said plate, a wall connecting said side flanges near one end of said plate, the space between said wall and the contiguous end of said plate being adapted to receive envelopes, corner plates provided at the opposite end of said holder and between which corner plates and the bottom plate the corners of the blanks are slipped, substantially as described.

5. An order blank holder comprising a back plate, means provided on the edges of said plate and between which means order blanks are placed, retaining devices adapted to overhang the corners of the blanks at one end of said plate, a cross wall near the opposite end of said plate, a flange mounted thereon and adapted to overhang one end of the blanks and a compartment being provided between said cross wall and the end of said plate and adapted to receive envelopes placed one above another therein.

In witness whereof, I have hereunto set my hand this 13th day of June 1907.

PLATT W. LYON.

Witnesses:

J. B. ERA,

J. H. BALDWIN.