

J. M. BROWNING.  
AUTOMATIC FIREARM.  
APPLICATION FILED AUG. 18, 1905.

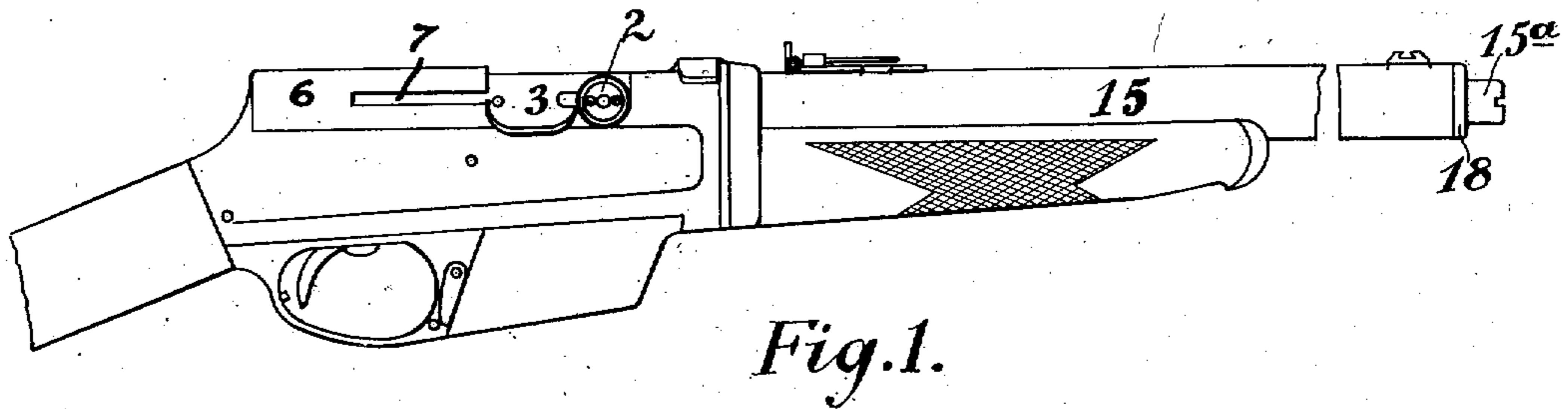
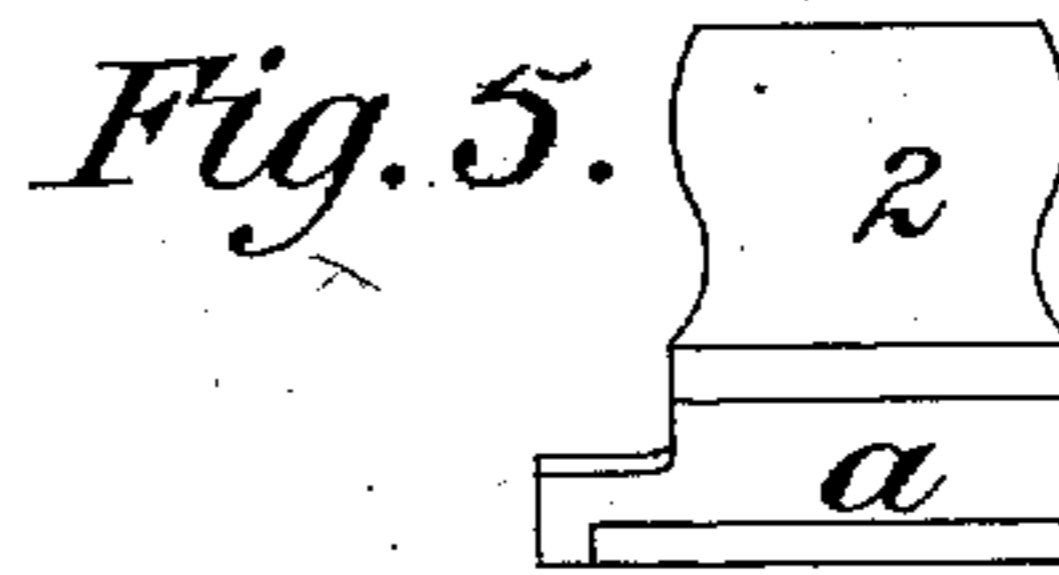
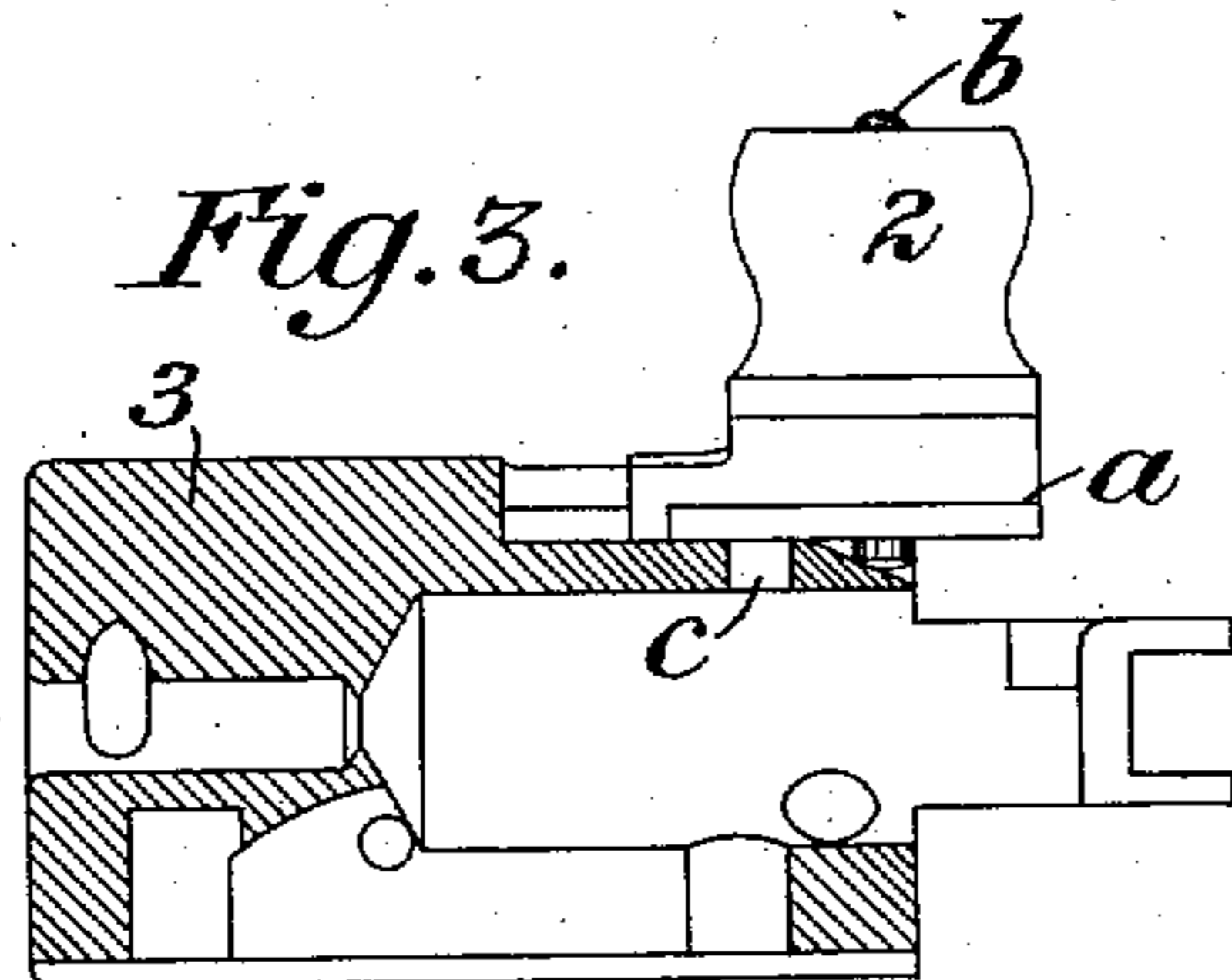
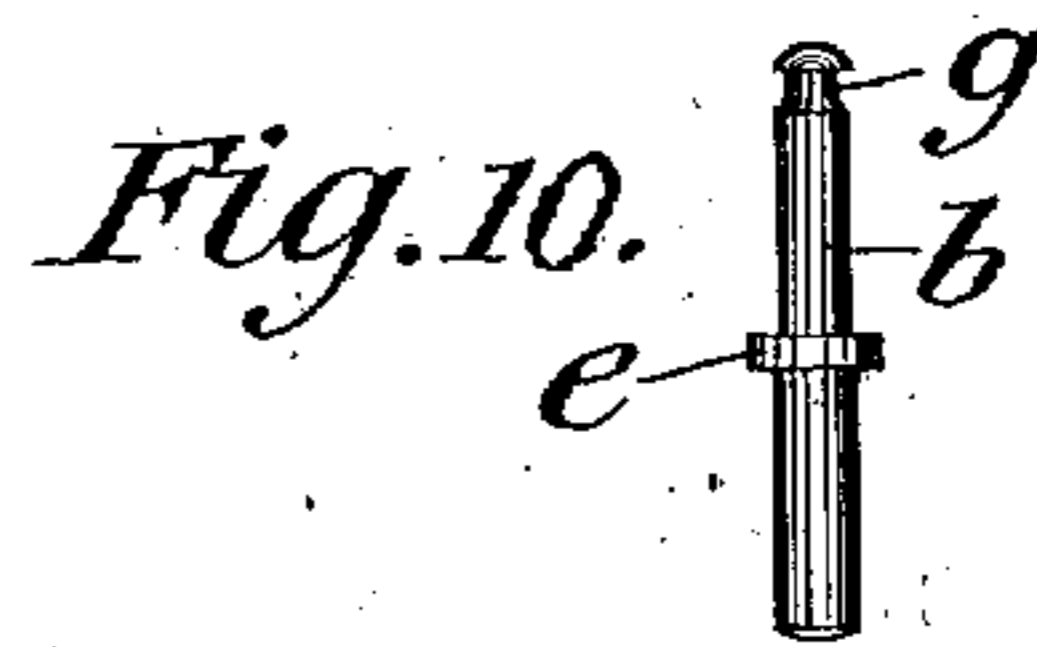
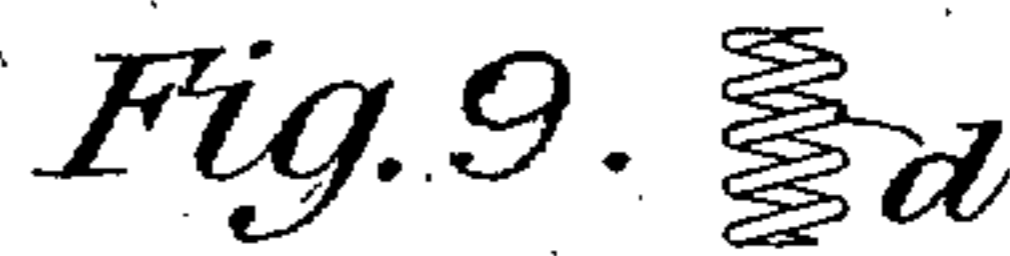
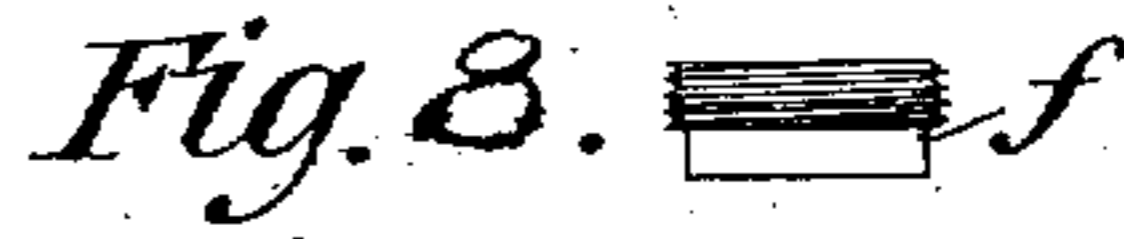
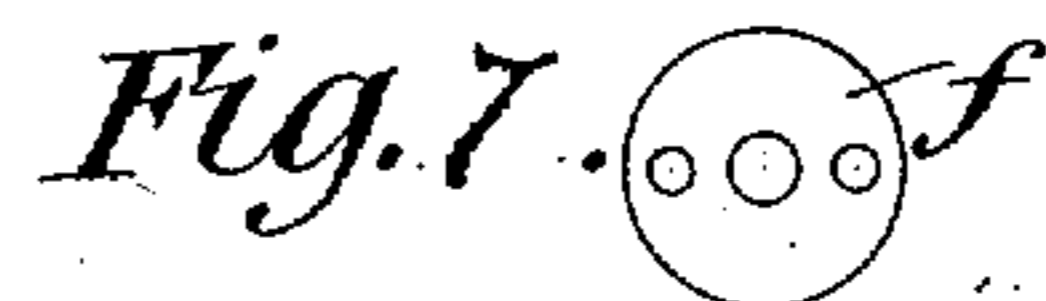
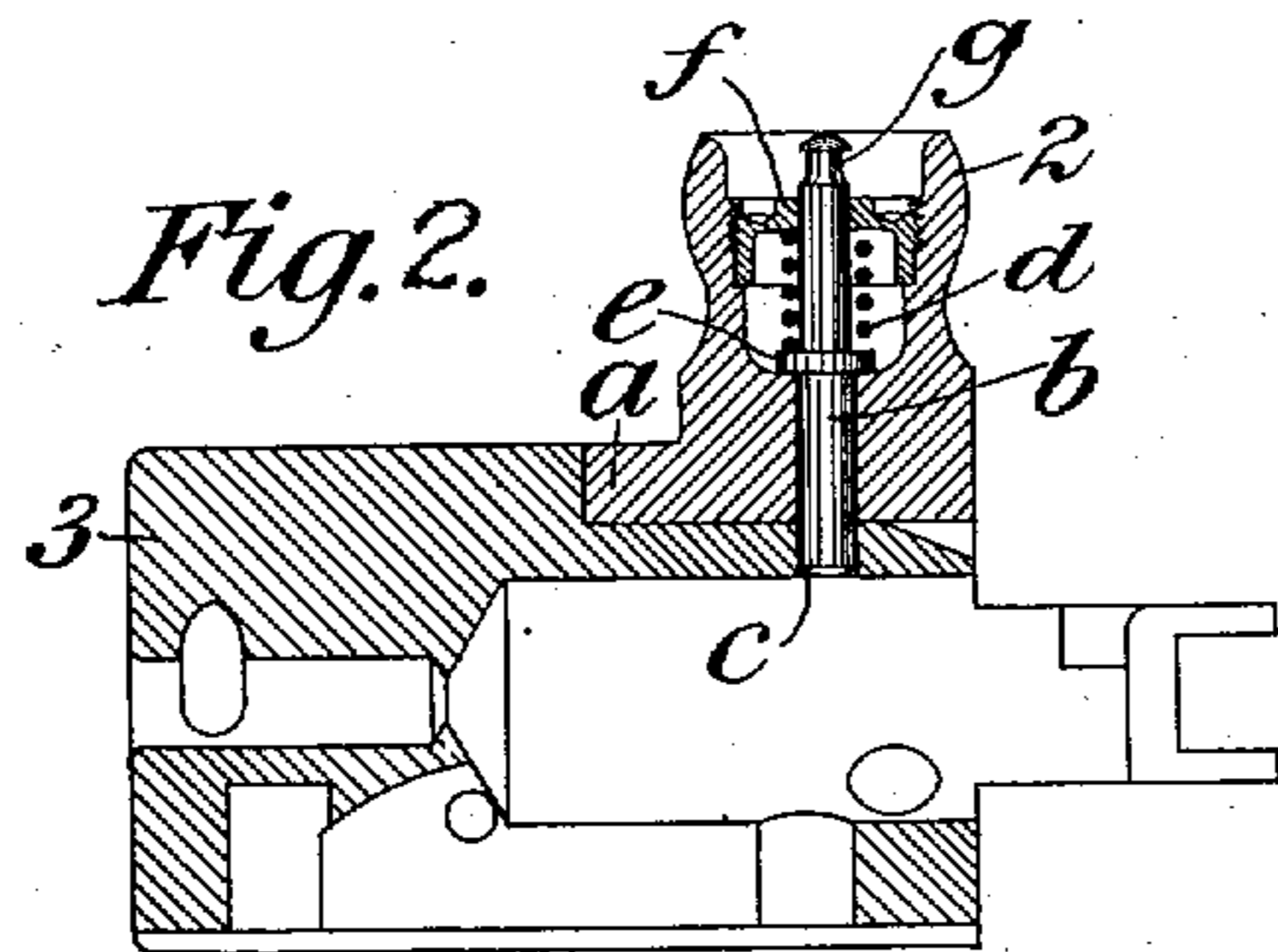
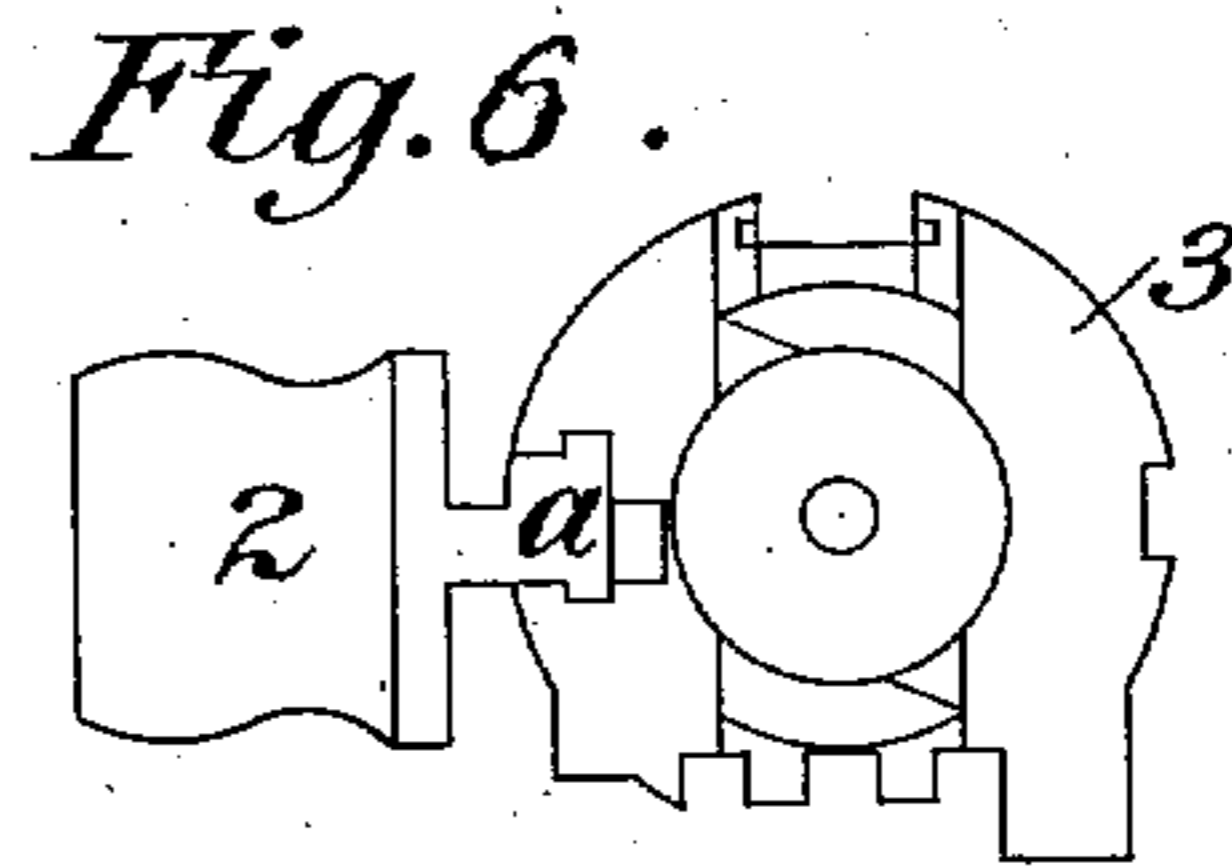
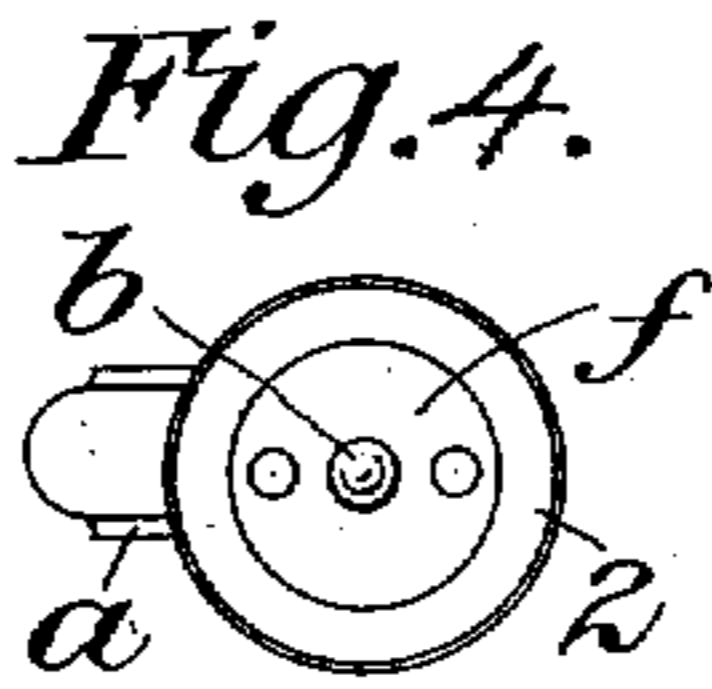

Witnesses  
Lucius E. Varney  
Roy Knowl.

Inventor  
John M. Browning  
By his Attorneys  
Redding Kiddle Hubley.

# UNITED STATES PATENT OFFICE.

JOHN M. BROWNING, OF OGDEN, UTAH.

## AUTOMATIC FIREARM.

No. 853,438.

Specification of Letters Patent.

Patented May 14, 1907.

Application filed August 18, 1905. Serial No. 274,689.

*To all whom it may concern:*

Be it known that I, JOHN M. BROWNING, a citizen of the United States, and a resident of the city of Ogden, in the county of Weber and State of Utah, have invented certain new and useful Improvements in Automatic Firearms, of which the following is a specification, reference being had to the accompanying drawing, forming a part hereof.

10 This invention relates to automatic firearms such, for instance, as are shown and described in Letters Patent of the United States No. 659,786, issued to me October 16, 1900; and the general object of the invention is to improve in certain particulars the arm shown and described in said Letters Patent, although the improvements are capable of being applied to other firearms of like general character.

20 The invention concerns the taking down of the gun. In doing this, the handle upon the bolt mechanism by means of which the gun is manually opened and which handle works in a slot in the receiver, has to be removed before the bolt and its associated parts can be pushed out from the forward end of the receiver. This handle therefore, in accordance with the present invention, is fastened to the bolt mechanism in such a way as to be readily attached and detached as required.

The invention will be more fully described with reference to the accompanying drawing in which the improvements are illustrated in a convenient and practical embodiment.

35 In said drawing: Figure 1 is a view in side elevation of an arm to which the improvement may be applied; Figs. 2 and 3 are sectional views of the bolt carrier, Fig. 2 showing the handle and its parts in section, and Fig. 3 showing the handle in elevation; Figs. 4 and 5 are respectively an end view and a view in side elevation of the handle; Fig. 6 is a view in front elevation of the bolt mechanism; Figs. 7 and 8 are respectively a top view and a side view of the nut in the handle; and Figs. 9 and 10 are respectively a view in elevation of the spring and a view in elevation of the pin in the handle.

50 The bolt mechanism, as in the Letters Patent above referred to, includes a bolt carrier 3 which moves backward in the receiver 6 together with the barrel upon each recoil, and then moves forward again and closes the breech. During this operation the handle 2 upon the carrier works in a slot 7 as will be

obvious from Fig. 1 and as has already been described in said Letters Patent.

In accordance with the present invention, the handle and carrier are formed with a sliding connection such as a dove-tail connection, whereby the handle, when the gun is to be taken apart, may be slid out from the carrier and removed from the carrier and whereby the carrier may then be pushed forward out of the receiver. In the present case, the handle is shown to have a T-shaped portion *a* and the carrier a correspondingly shaped groove in which this T-shaped portion is adapted to slide. In order to secure the handle within the groove in the carrier in such a way that it may be readily attached and detached therefrom, means such as a pin *b* extending through the handle so as to be accessible from the exterior thereof is provided. This pin is adapted to engage a recess *c* in the carrier and thereby to hold the handle firmly within the groove in the carrier.

In order to keep the pin *b* in the recess *c*, any suitable means may be employed, such, for instance, as a spring *d*, one end of which may abut against the shoulder *e* upon the pin while the other end of which rests against a nut *f* threaded in the end of the handle. In this way the pin is normally held in its recess and may be quickly and easily removed by the finger. If desired, a groove *g* may be provided upon the outer end of the pin in order that the end of the pin may be the more conveniently grasped.

Various changes in the construction shown and described herein may be made without departing from the spirit of the invention, and the improvements are not limited therefore to the present embodiment thereof. Furthermore, as was stated at the outset, the improvements are not limited in application to the gun mechanism shown and described in the present case nor to the mechanism shown and described in the Letters Patent above referred to.

I claim as my invention:—

1. In a fire arm, the combination with the receiver and breech mechanism, of a handle detachably secured to the said mechanism and working in a slot in the receiver, and means in the handle whereby the handle may be secured to and detached from the bolt mechanism.

2. In a fire arm, the combination with the receiver and breech bolt mechanism, of a

handle detachably secured to said mechanism and working in a slot in the receiver and a pin extending through the handle whereby the handle may be secured to and detached  
5 from the bolt mechanism.

3. In a fire arm, the combination with the receiver and breech bolt mechanism, of a handle for moving said mechanism, said handle working in a slot in the receiver and  
10 having a sliding connection with the bolt mechanism, and a spring actuated pin adapted to fasten the handle to the bolt mechanism and accessible from the exterior of the handle whereby the handle may be secured  
15 to and detached from the bolt mechanism.

4. In a fire arm, the combination with the receiver, breech bolt and breech bolt carrier, of a handle having a sliding connection with the carrier and working in a slot in the receiver, a pin extending through the handle  
20 and adapted to engage a recess in the carrier to lock the handle thereto, and a spring to hold the pin normally in the recess.

This specification signed and witnessed this 14th day of August, 1905.

JOHN M. BROWNING.

Signed in the presence of—  
HENRY J. WELLENKAMP.  
THEO. D. W. MOORE.