

No. 822,851.

PATENTED JUNE 5, 1906.

A. BURGESS.
AUTOMATIC GUN.
APPLICATION FILED NOV. 3, 1904.

2 SHEETS—SHEET 1.

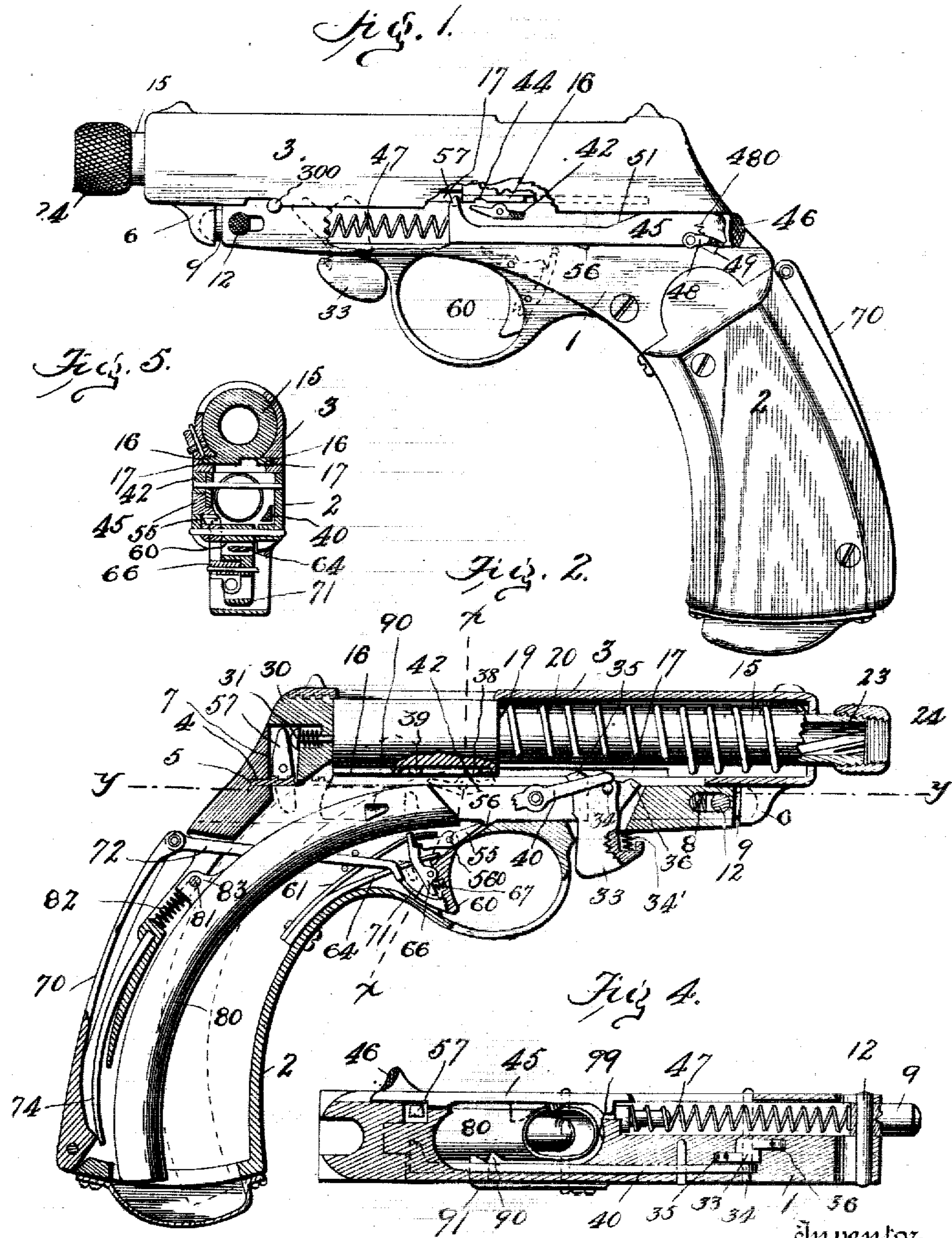

Witnesses
Chas. H. Davis.
Robt. W. Leib

Inventor
A. Burgess
By
W. A. Bartlett
Attorney

No. 822,851.

PATENTED JUNE 5, 1906.

A. BURGESS.
AUTOMATIC GUN.
APPLICATION FILED NOV. 3, 1904.

2 SHEETS—SHEET 2

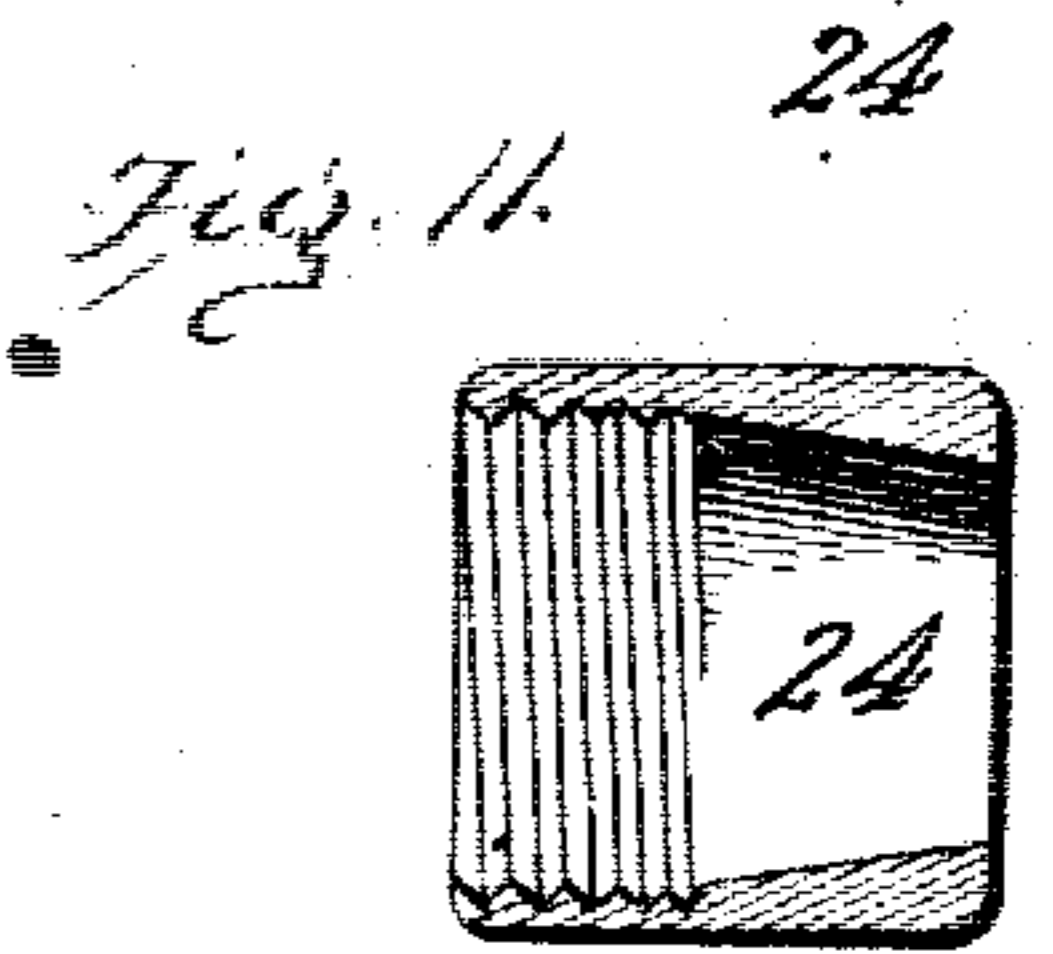
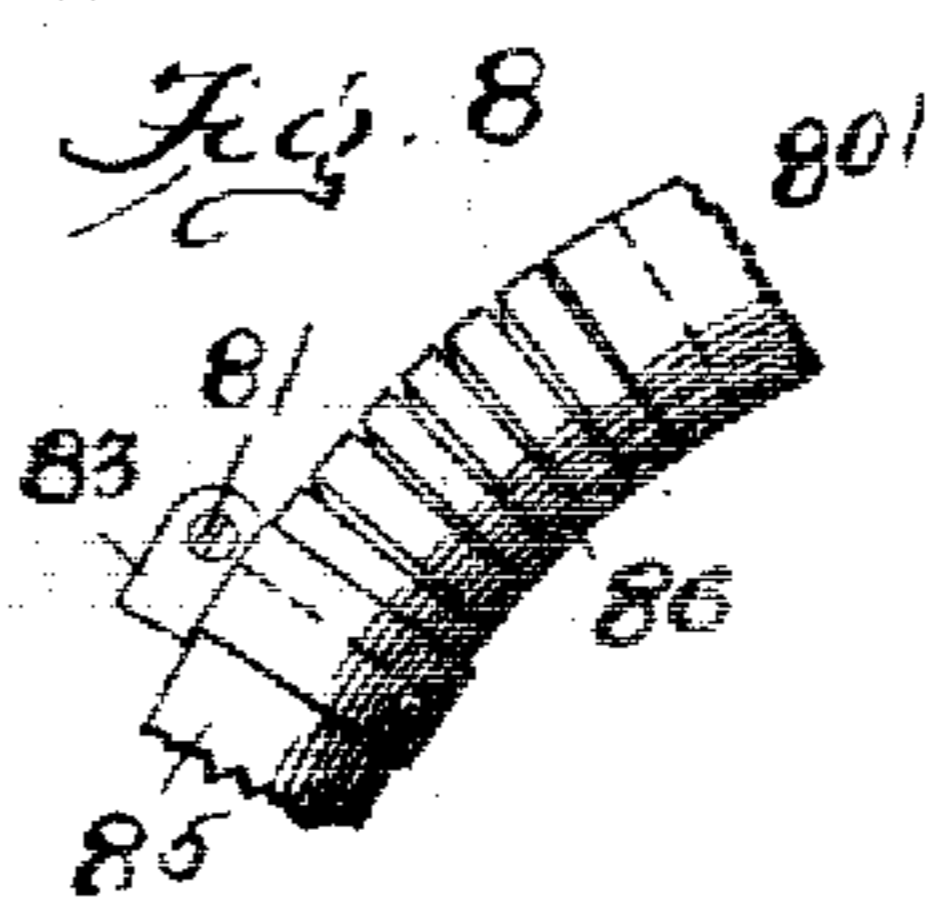
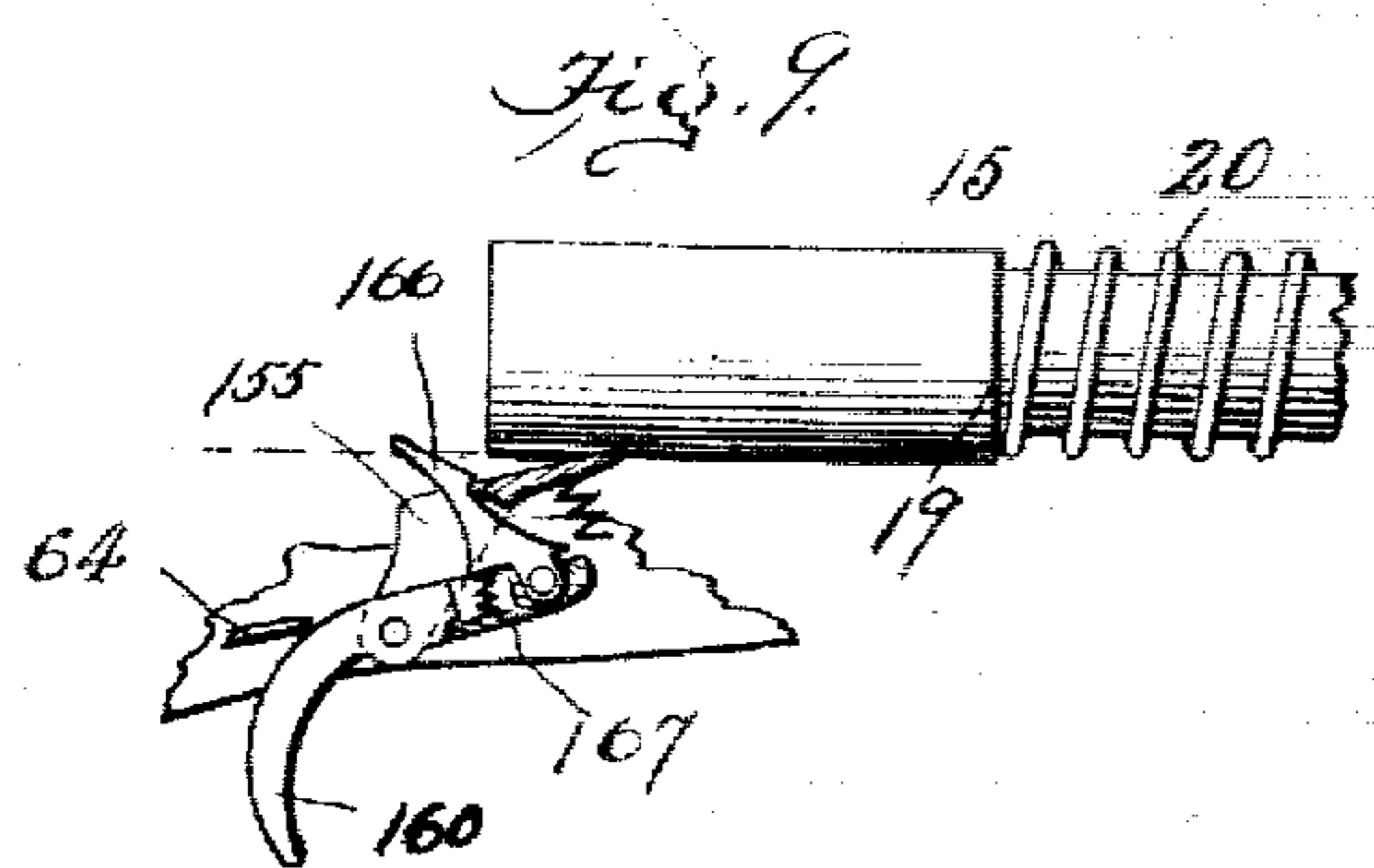
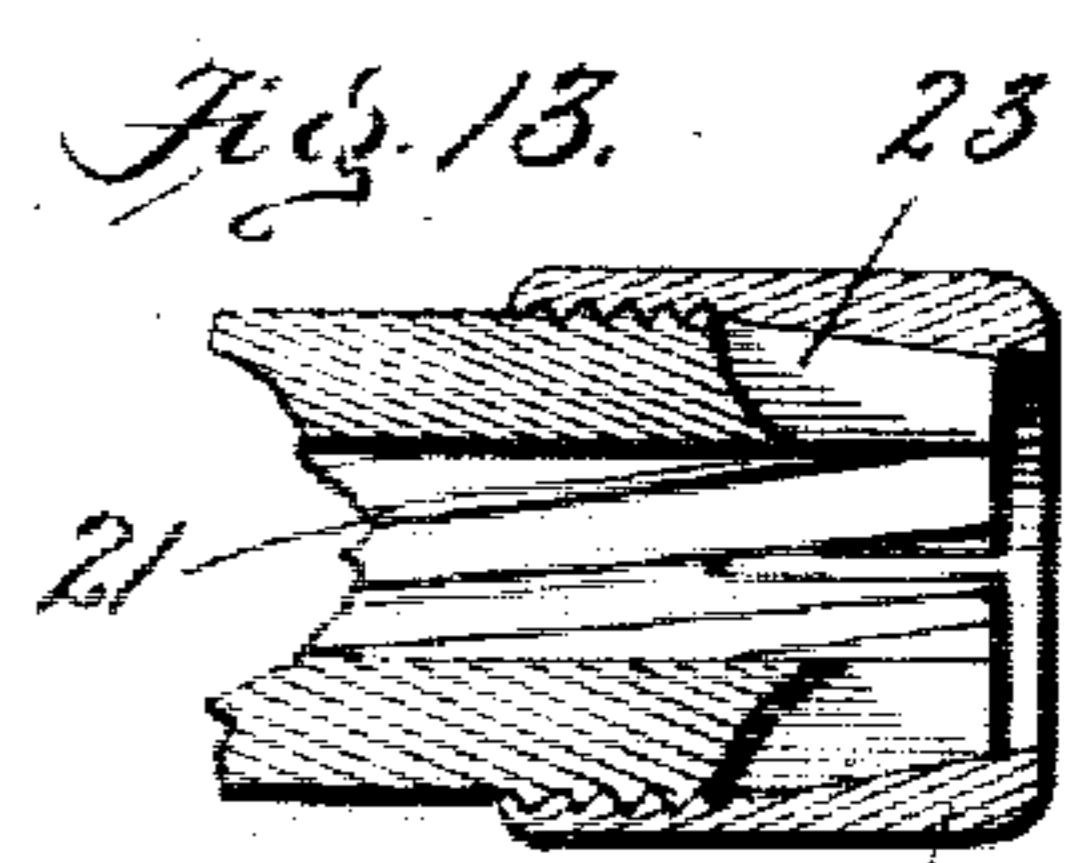
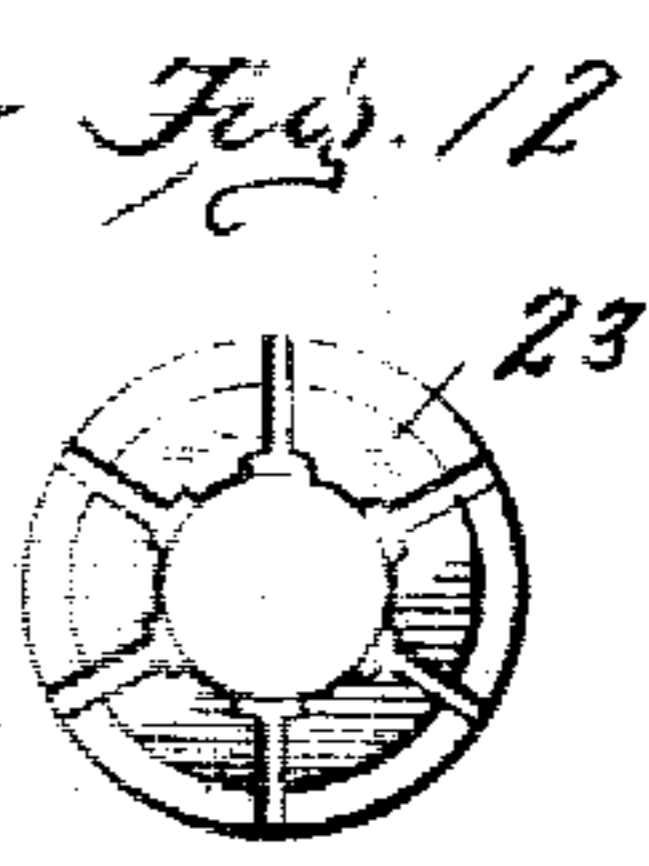
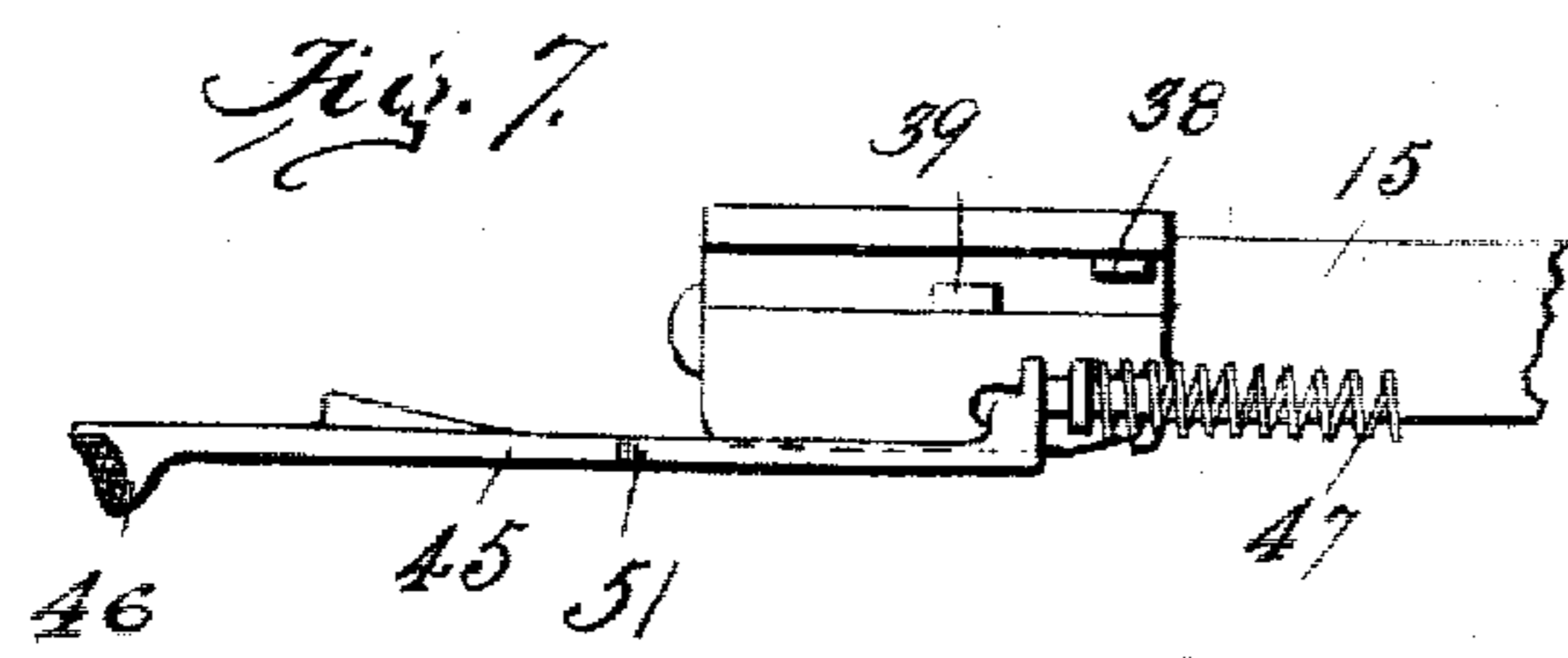
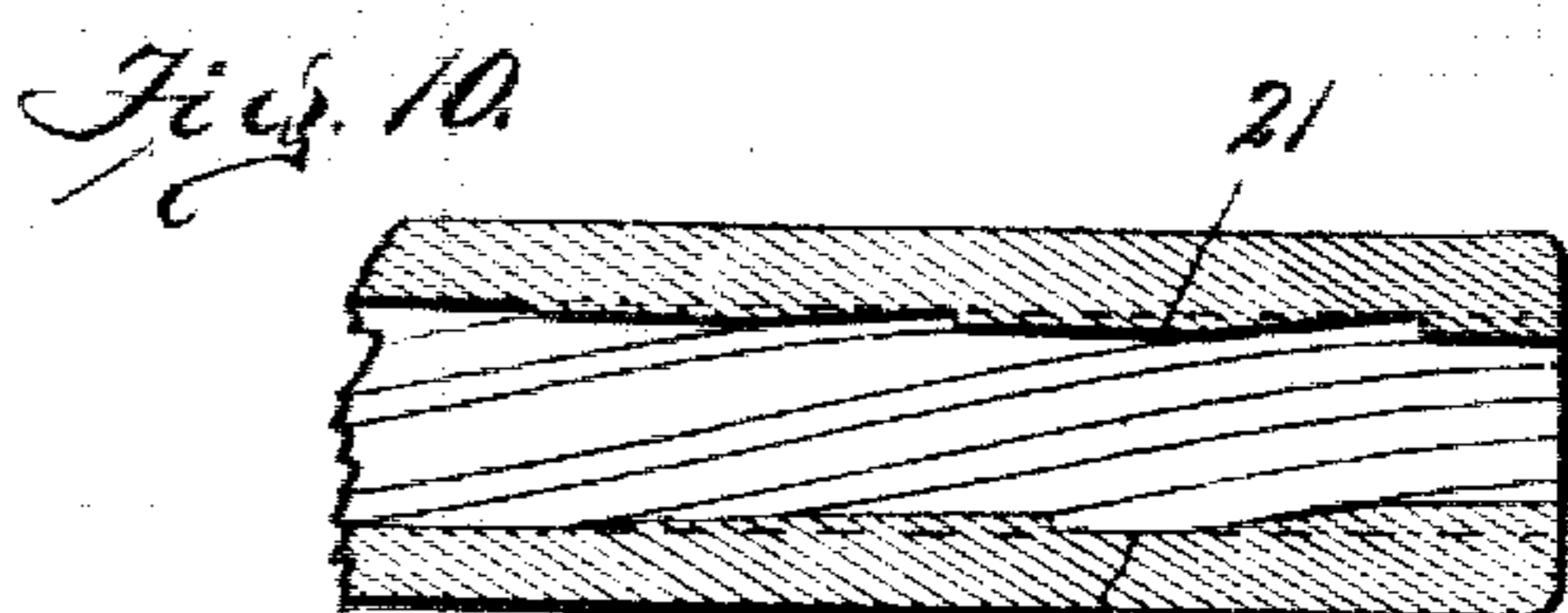
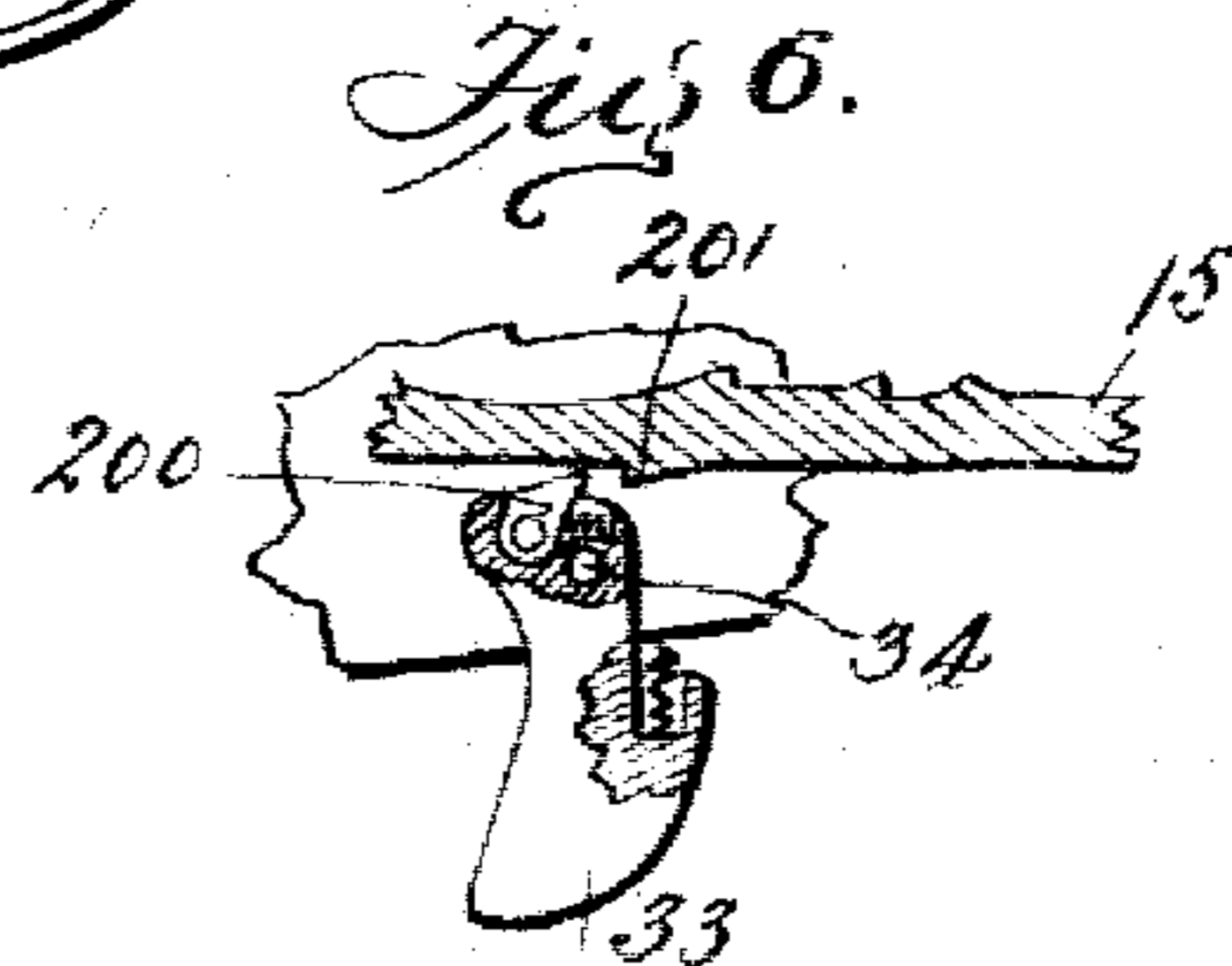
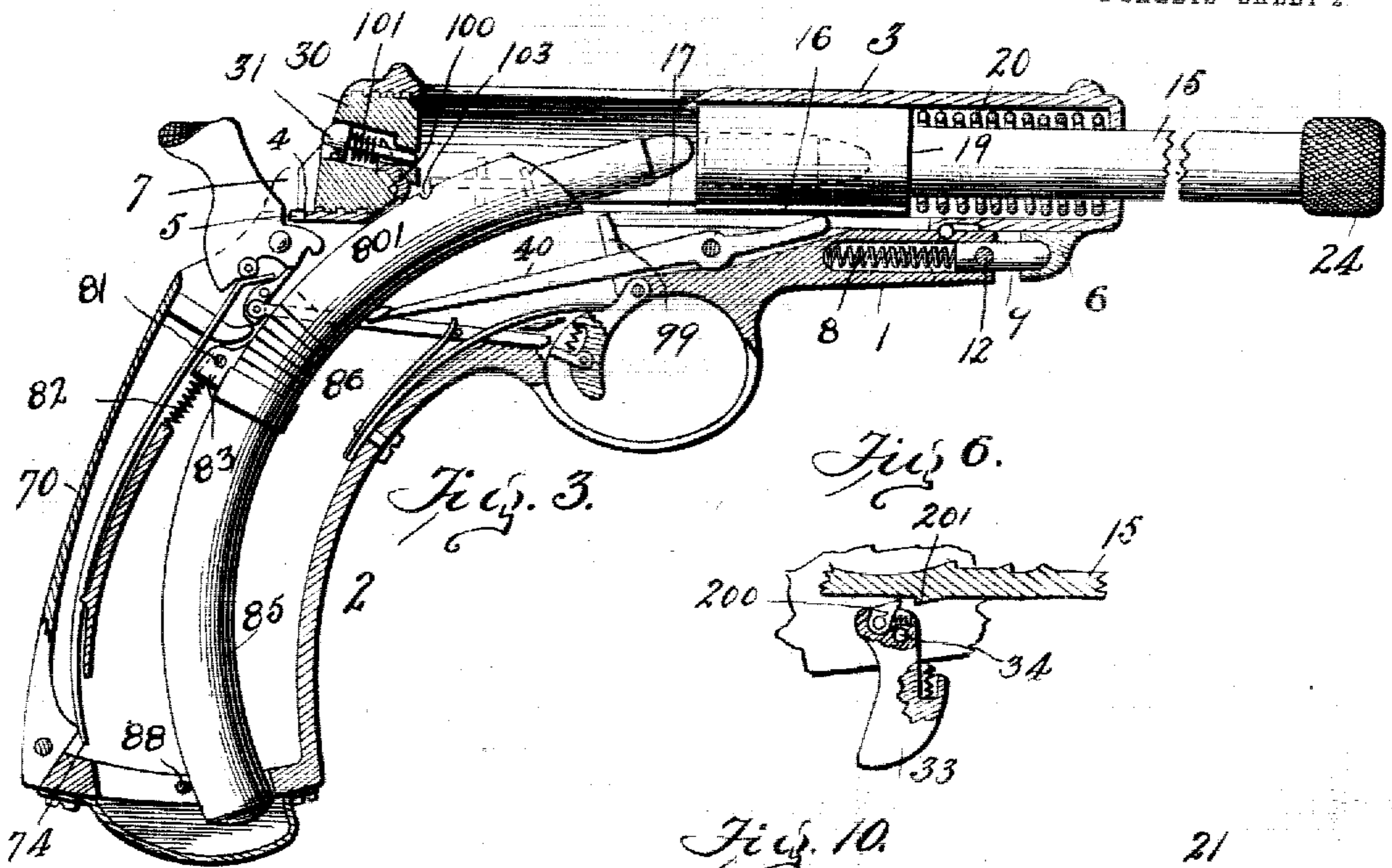

Witnesses
Chas. K. Davis
P. H. W. Smith

Inventor
A. Burgess
By *W. A. Bartlett*
Attorney

UNITED STATES PATENT OFFICE.

ANDREW BURGESS, OF OWEGO, NEW YORK.

AUTOMATIC GUN.

No. 222,851.

Specification of Letters Patent.

Patented June 5, 1906.

Application filed November 3, 1904. Serial No. 231,279.

To all whom it may concern:

Be it known that I, ANDREW BURGESS, a citizen of the United States, residing at Owego, in the county of Tioga, and State of New York, have invented certain new and useful Improvements in Automatic Guns, of which the following is a specification.

My invention relates to automatic guns.

The object of the invention is to make an automatic gun or pistol which is compact, convenient, and safe to carry in a holster or pocket.

The invention consists of certain improved constructions and combinations whereby an automatically-opening gun can be controlled as to movement of barrel and breech; also of means to bring the barrel opening and cocking mechanism into such interrelation that one may on occasion control the other; also to improve the barrel-mount; also to improve the firing mechanism and to place the operation of firing well under control of the trigger; also to improve the magazine, the safety mechanism, and various parts of the firearm, as will be hereinafter claimed.

Figure 1 is a side elevation, partly in section or broken away, of a pistol involving the principles of my invention. Fig. 2 is a longitudinal section, with parts in elevation, of the pistol with breech closed. Fig. 3 is a similar section with breech open, some parts being modified. Fig. 4 is a section on line *y y*, Fig. 2, looking downward. Fig. 5 is a section on line *x x*, Fig. 2. Fig. 6 is a broken detail, partly in elevation and partly in section, of the inertia-brake or barrel-retarder modified. Fig. 7 is a bottom plan of the barrel, hammer, and mainspring. Fig. 8 is a broken detail elevation of a portion of a flexible magazine. Fig. 9 is a view of a modification of the barrel, trigger, and sear. Fig. 10 is a longitudinal section of the front portion of a barrel contracted forward. Figs. 11, 12, and 13 are different views of a caliber-reducing mechanism for the front of the gun.

Let 1 indicate the frame of a gun, which may have a pistol-stock 2 or any other approved stock. The frame 1, with the stock, contains most of the movable parts of the weapon.

The barrel-casing 3 is a metallic shell, which is preferably attached in removable manner to the frame. In Fig. 2 the barrel-casing 3 has a rearward extension 4 from its lower sur-

face, and this extension 4 enters a recess 5 in the frame when the casing is in place thereon. The barrel-casing is bored from the rear with an opening at the front through which the front portion of the barrel slides. The rear end of the casing is closed by a removable piece 30. The barrel and casing are held against forward movement by a pin or catch 300 in the frame passing through a notch in the casing, as shown in Fig. 1

At the front of the barrel-casing there is a rigid downwardly-projecting lug 6, in which there is a recess or depression. An opening in the frame, preferably of cylindrical form, contains a coiled spring 8, which spring presses the pin 9 outwardly into the recess or depression in the lug 6, thus holding the barrel-casing locked to the frame.

When it is desired to remove the barrel-casing from the frame, pin 9 may be drawn back by the thumb and finger of the operator taking hold of pin 12, which projects from pin 9 through slots in the side of the frame. The pin 9 thus acts as a spring-bolt to hold the barrel-casing locked to the frame when desirable, and the said casing and barrel can be readily removed.

A small amount of longitudinal movement may be permitted to the barrel-casing by leaving a space between lug 6 and the front end of the frame and between the rear of said casing and an abutment 7 on the frame. The spring-pressed pin 9 will hold the barrel-casing forward normally; but when the gun is fired the casing will recoil slightly as the barrel moves forward, thus reducing the kick of the gun and accelerating the opening of the barrel. It may also cock a vibrating hammer as shown in Fig. 3, by engagement of its rear projection 4.

The barrel 15 is constructed to slide lengthwise of the barrel-casing to open the breech. The rear portion of the barrel has side wings 16 16, which may be integral with the barrel, and these wing 16 enter grooves 17, made in the barrel-casing to receive them. (See Figs 2, 3, and 5.) The barrel has a shoulder 19, against which spring 20 bears to close the breech, said spring having its front bearing against the casing. The barrel is opened in firing by the friction and impulse of the charge in passing through its bore.

The breech-piece 30 is preferably screwed

into the barrel-casing and contains firing-pin 31, when such is used.

With a short barrel it often happens that the friction of the bullet is not great enough to fully open the barrel on firing, or it may happen that a pistol which works perfectly with one kind of ammunition will not operate with a different ammunition. To insure that the barrel shall offer enough resistance to the bullet or charge to secure its opening, I may make the barrel with a slightly-tapered bore, as indicated in Fig. 10. Preferably the taper may be formed by the lands 21 increasing in height toward the muzzle of the gun, the grooves 22 being of uniform caliber from rear to front, although this is not essential.

The contraction in the bore may be made adjustable. A convenient means for adjustment is to provide the outside of the barrel near the muzzle with a tapered portion 23, which portion is externally screw-threaded and longitudinally slotted. A tapered screw-threaded sleeve 24, applied to this tapered portion of the barrel, will compress the same to a greater or less extent as the sleeve is screwed on. Means is thus provided for regulating the amount of friction which a passing bullet may have on the barrel, and the gun is thus adapted for use with various kinds of ammunition.

It is desirable to check the rapidity of the return-barrel movement under some conditions, so that the magazine may have time to feed a cartridge into the barrel. For the purpose of insuring sufficient time for the cartridge-feed, I provide an inertia-check piece 33, having a heavy lower portion which is pivoted in the frame at 34, Fig. 2. This piece 33 has a rear arm 35, which is inclined downwardly and rearwardly. A lug 39 on the barrel encounters this inclined arm during the forward movement of the barrel and forces said arm down, thus rocking the inertia-piece against the resistance of its own inertia, and also the resistance of spring 34', which spring is interposed between the inertia-piece and the frame.

The rocking down of arm 35 rocks up arm 36, which extends into the path of movement of and behind lug 38 on the barrel. The inertia-piece thus acts as a frictional brake or retarder as well as an inertia detaining or controlling piece during the final opening and the beginning of the closing movement of the barrel. The engagement of a projection on the barrel rocks the inertia-piece into position to be engaged by another projection as the barrel returns.

Fig. 6 shows a modification of the inertia-check in which but one spring-arm is used. The heavy portion 33 extends below and is pivoted to the frame as before. The spring-arm or "fly" 200 is hung rearward of the

pivot 34 to spring up against the bottom of the barrel or breech-closing element, as shown in Fig. 6, in which figure the breech has been fully opened and the projection 201 on the barrel has engaged the fly 200, turning its point downward, so said projection can ride over it.

As soon as the projection 201 passes the fly, as shown, said fly will be instantly turned up by its spring to then be in the path of the return movement of said projection 201, which will then check the closing of the breech, while the heavy part 33 is being moved, and the fly is turned below the path of movement of projection 201. I show the inertia-check applied to a sliding barrel; but it is obviously applicable in a like and equivalent manner to any other known sliding breech mechanism.

In my patent No. 666,084 of January 15, 1901, I show and describe an inertia-piece arranged to hold the barrel in its closed position at the instant of firing. This is quite different in function from the present invention, in which an inertia-piece checks or retards the movement of the barrel when the breech is open, so as to give more time for the cartridge movement.

The lever 40, pivoted in the frame and engaged by the shoulder 19 on the barrel, and the enlarged portion of the barrel in rear of said shoulder serves to swing the front of the magazine into feeding position when the barrel is forward.

I provide a safety-pawl 42, pivoted in the casing and having its finger-piece extending outside. This pawl can be turned by hand and is calculated to remain in the position in which it is placed, being held by friction. The barrel has a notch 44 in its lower surface. The barrel can be drawn forward a little way, and this pawl 42 swung so as to enter the notch, and thus hold the barrel forward, so that an accidental blow on the firing-pin will not explode a cartridge contained in the barrel. When the barrel is drawn fully forward, the pawl 42 can be swung so as to present its nose behind the barrel, and thus hold the breech open for loading or inspection.

The hammer which I prefer is a reciprocating hammer which slides in a groove in the side of the frame and is cocked by a forward movement. Such a hammer is shown at 45. The hammer is cocked (by hand for the first shot) by pressing forward on the thumb-piece 46, thus compressing main-spring 47. A dog 48, pivoted to the hammer, may be swung into notch 49 in the frame when the hammer has been pressed a little way forward and will act as a half-cock sear. The dog 48 may be pressed into notch 49 by a light spring 480. The backward movement of the hammer is not interrupted by such dog when the hammer strikes, as the

dog rides past on the same principle that the usual half-cock notch does not stop a firing-hammer. An inclined shoulder 51 on the hammer engages pawl 42 when the hammer is pushed forward nearly to full-cocked position, thus releasing the barrel if said barrel has been held forward by said pawl, and spring 20 will then close the barrel rearwardly. The hammer is held in full-cocked position by sear 55, which is pivoted on the same pivot 560 as the trigger, and the sear engages a shoulder 56 on the hammer when the same is full cocked. In striking to the rear the hammer engages lever 57, pivoted in the frame, and this lever communicates the blow to firing-pin 31.

Automatic cocking of the hammer is effected after the first shot by the engagement of wing 16 on the barrel with the lug 57 of the hammer. Some lost motion is allowed, so as not to move the hammer too far. Whether the hammer be moved forward by the pressure of the thumb or by the movement of the barrel the hammer will be caught by sear 55 and held cocked until the trigger 60 is pulled. The hammer should be released from the pressure of the mainspring the instant before its blow becomes effective, as is common.

The sear 55 is pivoted in the frame, and its front end is pressed toward the hammer by spring 61. The trigger 60 is preferably pivoted on the same pin 560 as the sear. The trigger carries a spring-pressed pawl 66 to couple with the rear end of the sear when the trigger is in forward position, to which it is pressed by spring 64.

On pulling the trigger the pawl 66 presses up the rear end of the sear, thus releasing the hammer. In its backward movement projection 56 of the hammer strikes the upper end or arm of pawl 66 and knocks this pawl back from under the sear, thus uncoupling these parts. The sear then moves to position to catch the hammer when it is cocked whether the trigger is released or not. The release of the trigger causes it to move forward so that its pawl 66 again catches the sear by force of the pressure of its spring 67.

In the modification, Fig. 9, the trigger 160 is pivoted in the frame and sear 155 has the same relation as before. A hook 166 is pivoted in the front end of the trigger and is pressed up by a spring 167. (In this modification the barrel itself acts as a hammer.) When the trigger is pulled, its hook pulls down the sear and as the barrel moves back it knocks the hook 166 away from the sear, when the sear is again free to rise whether the trigger be released or not. Any moving part which uncouples the movable hook or pawl of the trigger from the sear effects a like result.

The stock is provided with a grip-plate 70, which, with its connections, acts as a safety

device to block the trigger unless the handle is so grasped as to press in this grip-plate. The grip-plate 70 is pivoted near the lower part of the stock and will rest against the hand which holds the pistol in firing position.

A curved horn 71 extends back from the trigger. An arm 72 reaches forward from the grip-plate into the frame and normally the horn 71 encounters the turned-down end of this arm 72 and is locked thereby; but when the stock is firmly grasped the grip-plate, with its arm 72, is pressed forward so that the turned-down end of the arm passes from over horn 71. (See dotted lines.) The trigger may then be pulled without obstruction from arm 72. The spring 74 tends to hold back the grip-plate and also acts to cushion the hand against the shock of firing.

The magazine 80 is curved and is inclosed and pivoted in the stock, the pivot 81 passing through a lug 83 on the magazine-tube and being guided in a slot in the stock, so that the magazine may not only swing on its pivot, but may also be depressed against the pressure of spring 82, which tends to lift the lug 83 and move the top of the magazine forward.

The lever 40, pivoted in the frame, is depressed at its front end by the shoulder 19 on the barrel as the barrel moves forward, thus lifting the front of the magazine to the feeding position, Fig. 3, when the cartridge is pressed forward into the barrel by the usual spring-follower.

The front end of the magazine is inclined and is cammed down by the backward movement of the barrel. Lever 40 releases the magazine-tube soon after the barrel starts back. (Lever 40 is a spring-lever to allow a certain elasticity to the magazine movement.)

In the modification shown in Fig. 3 the magazine-tube is itself flexible, the upper part 801 being connected to the lower part 85 by a section of coiled metallic ribbon-tube 86, such flexible metallic tubing being well known. Then although the lower end of the magazine be rigidly held by the means of pin 88 the feeding part of the magazine will have sufficient mobility and less power will be required to swing the magazine, as the lower part filled with cartridges need not swing.

The magazine is loaded through the aperture shown in the top of the casing. To give more room for the loading, the magazine is made longitudinally movable.

When the barrel is drawn forward for loading, the magazine may be pressed longitudinally back or down against the spring 82. A hole 90 in the side of the magazine is thereby moved until a spring catch or pawl 91 springs into the hole and holds the magazine back. The end of the pawl 91, which enters the hole 90, is inclined and protruding through the hole serves as a cartridge-stop

as cartridges are pressed back into the magazine-tube.

In the modification in Fig. 3 the magazine 801 is pressed back against the resistance of spring 82 and a pin 100, pressed down by spring 101, enters a hole 103 in the magazine-tube. This spring-pressed pin thus serves to hold the magazine back and also serves as a cartridge-stop.

The mouth of the magazine is inclined, and when the barrel moves back the lower part of the barrel engages the magazine and rocks it down, releasing it from pin 100. When the magazine swings down, the abutment 99 on the frame serves as a cartridge-stop for the magazine. When it swings up, if the rear of the barrel be open in front of the magazine, the front cartridge moves into the barrel. If there be a cartridge or shell in the barrel, the magazine does not feed.

An extractor of usual form for this class of guns holds the fired shell against the breech-piece 30 as the barrel moves forward, and the rocking of the magazine under impulse of lever 40 serves to eject such shell through a hole in the top of the casing and move the magazine to feeding position.

I claim—

1. In an automatic gun, the combination of a frame, a barrel-casing removable therefrom and having a rear extension entering a recess in the frame, a catch for retaining said casing, and a barrel, and barrel-moving spring, substantially inclosed and reciprocating in said casing, all combined.

2. In an automatic gun, the frame, a barrel-casing having a limited longitudinal movement thereon, a barrel and its spring, substantially inclosed in said casing, a recoil-piece carried by the front of the casing, and a recoil-abutment on the frame to stop the rear of said casing.

3. The combination in an automatic gun, of a longitudinally-reciprocating barrel moved forward by the friction of the charge and having a reduced caliber or choke-bore at the muzzle, a barrel-casing having a breech-piece in rear of the barrel, and a spring adapted to close the barrel against the breech-piece.

4. The combination, in an automatic gun, of a frame and barrel casing, a longitudinally reciprocating barrel, means for closing the barrel rearwardly in the casing, and means for adjusting the muzzle-caliber of the bore of the barrel, so as to cause more or less friction on the bullet.

5. The combination of a barrel guided to longitudinal movement on the frame and sliding forward under the impulse of the charge, a spring to return the barrel rearward, and a compression-sleeve applied to the muzzle of the barrel to reduce the caliber thereof.

6. In an automatic gun, mechanism arranged to open the breech under the impulse of firing, and an inertia-piece arranged to retard the first closing movement of the breech-closing element.

7. In an automatic gun, the combination with a longitudinally-reciprocating breech-opening element, of an inertia-piece engaged by the said element at the close of its opening and beginning of its return movement, and acting as a brake and retarder.

8. In an automatic gun, the frame having a pivoted inertia-piece therein, and provided with a plurality of arms in different planes, a breech having a projection in position to engage with each arm, and a spring to close the breech, whereby the longitudinal movement of the breech brings its projections into successive engagement with the arms of the inertia-piece, thus retarding the breech.

9. In an automatic gun, the combination of a longitudinally-sliding barrel, having a notch therein, of a pawl on the frame adapted to swing into the notch and hold the barrel slightly forward, and means actuated by the cocking of hammer to release said pawl.

10. In an automatic gun, the combination of a longitudinally-sliding barrel, a pawl engaging said barrel to hold it open, and a hammer which engages said pawl during its movement and releases the barrel.

11. In a gun, the combination of a hammer which is cocked by sliding longitudinally forward, said hammer being pressed back by a spring, a firing-pin in rear of the cartridge, and a lever interposed between the hammer and firing-pin and free from both, whereby the hammer-blow drives the firing-pin forward.

12. In an automatic gun, the frame having a groove in its side, a hammer sliding forward in said groove and having a thumb-piece which may be pressed by the thumb of the hand while grasping the stock, a trigger and sear for holding the hammer cocked, and means for converting the backward blow of the hammer into a forward blow against the cartridge.

13. In a firearm, the combination of a hammer, a trigger, a sear pivoted on the trigger, and a spring-actuated coupling-piece pivoted to the trigger, and acting to bring the sear and trigger into rigid relation, and a moving part released by the pull of the trigger and acting to uncouple said parts.

14. In a magazine-gun, a magazine composed in part of a rigid tube, and in part of a flexible tube, and means for flexing the flexible portion of the tube to the desired curvature.

15. In a magazine-gun, a magazine-tube movably pivoted in the stock and having a hole therein, a spring pressing said tube forward, and a movable catch in the frame in position to enter the hole in the magazine-

tube and hold the tube against the pressure of the said spring.

16. In a magazine-gun, a movable magazine-tube having a hole therein, and a spring-catch in the frame in position to enter said hole and serve as a cartridge-stop when the magazine is in one of its positions.

In testimony whereof I affix my signature in presence of two witnesses.

ANDREW BURGESS.

Witnesses:

W. A. BARTLETT,
E. H. PARKINS.