

No. 767,972.

PATENTED AUG. 16, 1904.

J. S. STONE.

METHOD OF RECEIVING SPACE TELEGRAPH SIGNALS.

APPLICATION FILED SEPT. 10, 1902.

NO MODEL.

2 SHEETS—SHEET 1.

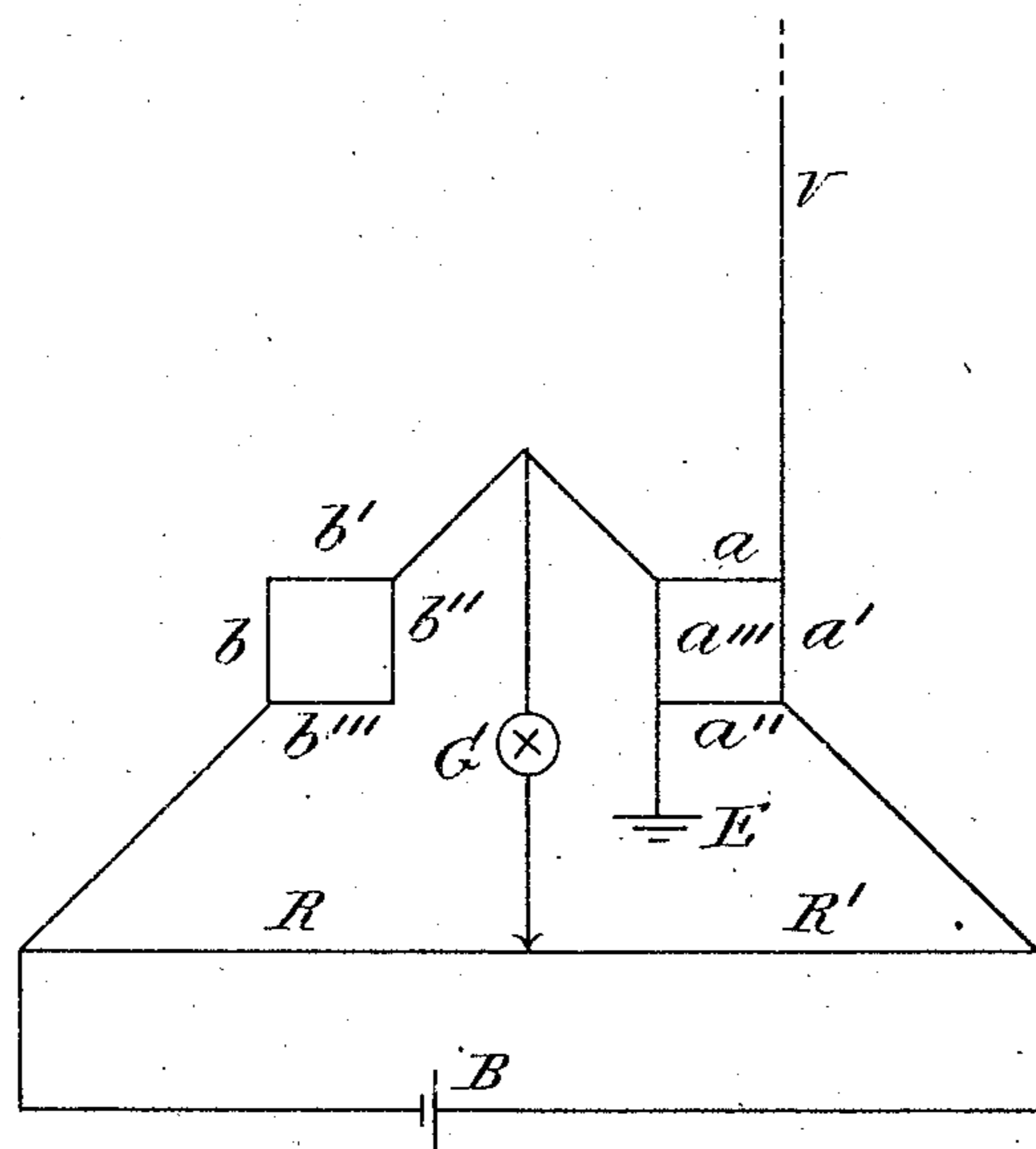

Fig. 1.

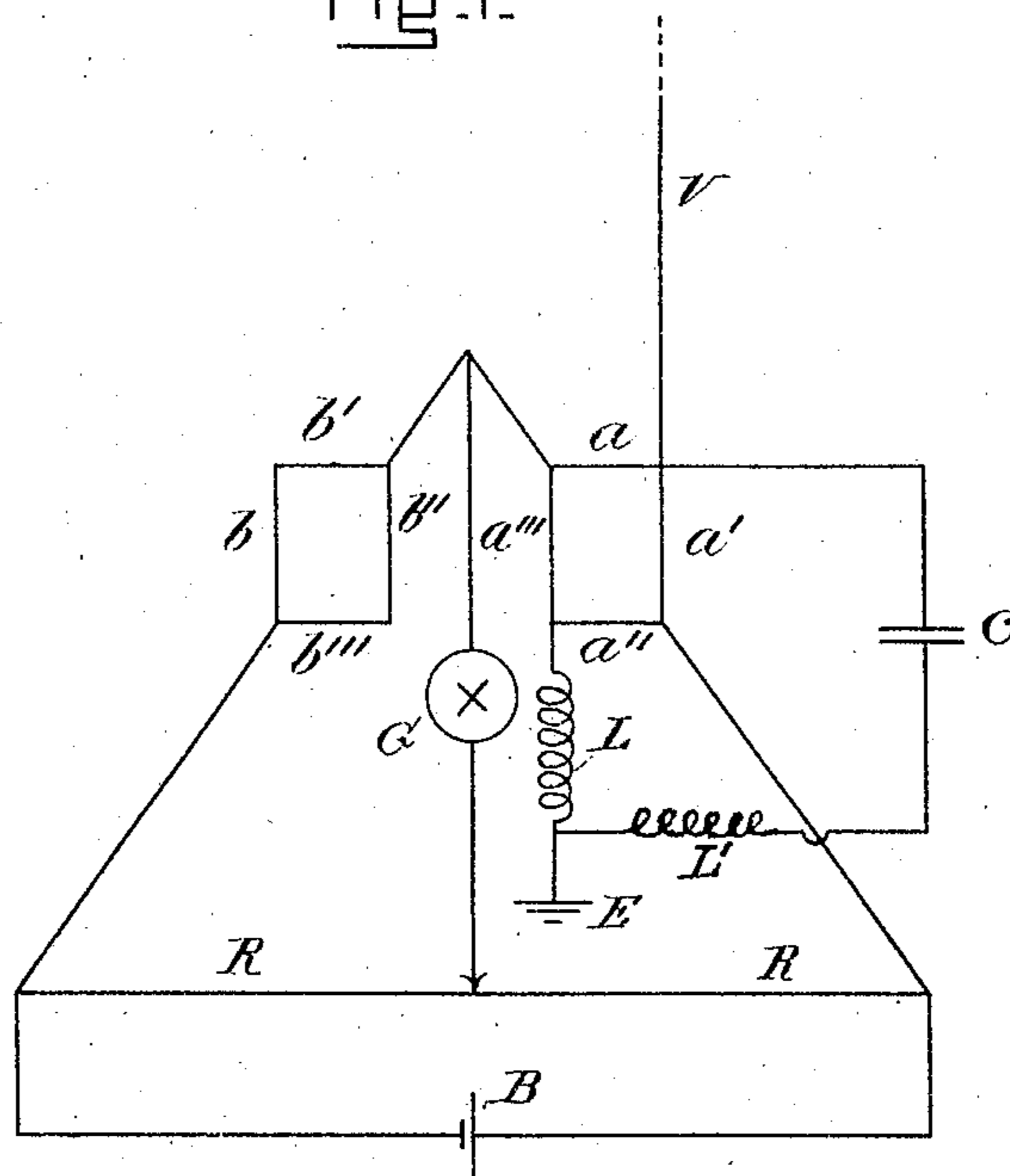

Fig. 2.

WITNESSES:

Edmund B. Tomlinson  
Jeremiah Toomey

INVENTOR:

John Stone Stone  
by Alex. P. Brown,  
att'y.

No. 767,972.

PATENTED AUG. 16, 1904.

J. S. STONE.

METHOD OF RECEIVING SPACE TELEGRAPH SIGNALS.

APPLICATION FILED SEPT. 10, 1902.

NO MODEL.

2 SHEETS—SHEET 2.

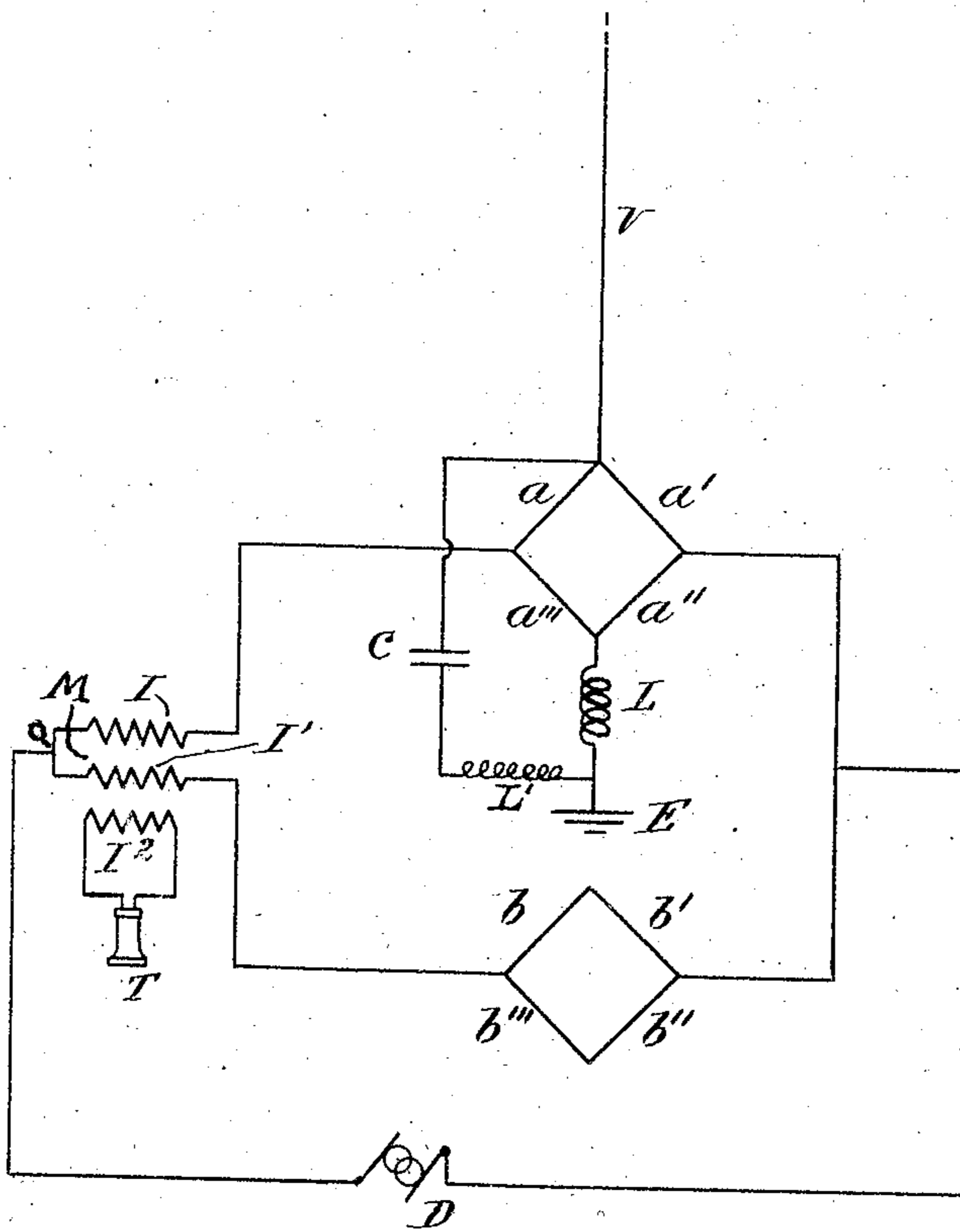

Fig. 3.

WITNESSES:

Eileen B. Tomlinson.  
Jeremiah Toomey.

INVENTOR:

John Stone Stone  
by Alex. P. Brown,  
att'y.

# UNITED STATES PATENT OFFICE.

JOHN STONE STONE, OF CAMBRIDGE, MASSACHUSETTS.

## METHOD OF RECEIVING SPACE-TELEGRAPH SIGNALS.

SPECIFICATION forming part of Letters Patent No. 767,972, dated August 16, 1904.

Original application filed August 11, 1902, Serial No. 119,211. Divided and this application filed September 10, 1902. Serial No. 122,853. (No model.)

To all whom it may concern:

Be it known that I, JOHN STONE STONE, a citizen of the United States, and a resident of Cambridge, in the county of Middlesex and State of Massachusetts, have invented certain new and useful Improvements in Methods of Receiving Space-Telegraph Signals, of which the following is a specification.

My present invention relates to electroreceptive devices for wireless or space telegraphy systems, and more particularly to such devices as depend for their operation upon the principle of the bolometer, which has for long been known and used as a means for detecting and measuring radiant energy.

In the bolometer as used by Professor Langley the change of electrical resistance of a conductor with temperature is employed to detect and measure the distribution of heat in the solar spectrum, and the development which this instrument has received at his hands has made it a far more sensitive instrument even than the thermopile both for the detection and measurement of exceedingly feeble radiation. This instrument has been so completely described in the scientific writings of Professor Langley and others that I need not take the space here to describe the instrument in its various forms and in its details of construction. Suffice it to quote here a bibliography in which the theory, construction, and sensitiveness of the instrument is more fully discussed than would be practicable in a patent specification.

*Bibliography of the Bolometer.*—Svanburg, *Pogg. Ann.*, Vol. XXIV, page 416, year 1851; Langley, *Proceedings of the American Meteorological Society*, December 23, 1880; Langley, *Proceedings of the American Academy of Arts and Sciences*, January 12, 1881, Vol. 1, Camb.; Langley, *American Journal of Science*, third series, Vol. 21, No. 123, March, 1881; Langley, *Comptes Rendus des Seances de l'Academie des Sciences*, Paris, September 11, 1882; Langley, *American Journal of Science*, Vol. 25, March, 1883; Langley, *Memoir, National Academy of Sciences*, April, 1883; Langley, *Professional Papers*

*of the Signal Service*, No. 15, War Department, December 21, 1883; Langley, *Proceedings of the American Association for the Advancement of Science*, Salem, August, 1885; Langley, *American Journal of Science*, Vol. 32, August, 1886; Langley, *American Journal of Science*, third series, Vol. 36, No. 216, December, 1886; Langley, *National Academy of Sciences*, Vol. 4, part 2, third memoir, Washington, November, 1887; Langley, *American Journal of Science*, Vol. 40, August, 1890; Langley, *Annals of the Astrophysical Observatory of the Smithsonian Institution*, Vol. 1, 1900; B. F. Snow, *The Infra-red Spectra of the Alkalies*, *Physical Review* 1, page 28, 1893; H. F. Reid, Ph.D., *Theory of the Bolometer*, *American Journal of Science*, third series, 35, page 160, 1888; O. Lummer and F. Kurlbaum, *Wied. Ann.* 46, pages 204-224, 1892; Baur, *Proc. Berlin Phys. Soc.*, March 3, 1882; Baur, *Ann. der Ph. und Ch.*, Vol. XIX, page 12, 1881.

Besides the use of the instrument for detecting radiant energy in the form of heat-waves the bolometer has been applied to the measurement of dielectric constants and to the detection and measurement of ordinary electromagnetic radiation, such as Hertz waves. (See Tachqlieeff, *Journal de la Societe Physico-Chimique Russ.*, page 115, 1890; also Rubens, Paalzow, Ritter, Arons, *Wied. Ann.* 37, page 529, 1889; 40, page 55, 1890; 42, page 154, page 581; 44, page 206; also *St. John Proc. Am. Acad.*, May 9, 1894.)

When the bolometer is to be used to detect electromagnetic radiations of wave lengths great compared to those of radiant heat, the electromagnetic waves are caused to develop a current in the bolometer wire or strip. The energy thereby converted into heat in the bolometer wire or strip raises its temperature, thereby increasing its resistance and unbalancing the bridge or induction-balance of which it forms a part.

When the bolometer is to be used as a signal-receiving device, it is necessary in order that it be quick to respond to the signals that the thermal time constant of the bolometer

wire or strip should be small, and for this reason the material of which the bolometer wire or strip is composed should be of small specific heat and that the wire or strip should be of small mass. It is also desirable for this purpose that the heat insulation of the wire or strip be not too perfect. In order to gain great sensitiveness, it is desirable that the bolometer wire or strip should be of a material having high specific resistance, a large resistance temperature coefficient, and a small specific heat.

An extended list of specific heats may be found in *Physikalisch-Chemische Tabellen* by Landolt and Bornstein, Julius Springer, Berlin, 1883. A list of the specific resistances and resistance temperature coefficients may be found in Mathiessen's tables. From these tables it will be seen that bismuth is superior to other of the commoner metals for the purpose of the bolometer wire or strip owing to its high specific resistance, high-resistance temperature coefficient, and low specific heat. It is an inconvenient material to use, however, owing to its mechanical properties being of small ductility and malleability. For this reason it is difficult to construct in fine wire or excessively thin strips for the purposes of the bolometer. For these reasons iron and platinum have been employed when from the other considerations bismuth would have been preferable, and a truly remarkable degree of sensitiveness has been obtained.

A simple method of employing the bolometer as an electric translating device in a wireless-telegraph system is illustrated in Fig. 1 of the drawings; but this method is not the preferred method, owing to the fact that in general the oscillatory current developed in the elevated conductor at a receiving-station is of small amplitude of strength, and unless the resistance of the bolometer fine wire or strips be excessively great but a small amount of energy will be dissipated in them. The response of the instrument to the signal-waves will therefore be under these conditions relatively feeble, and the rate at which the instrument can receive signals will be relatively slow. The method and apparatus shown in this drawing is, in fact, identical with the method and apparatus published by Rubens, Ritter, and others.

In order to adapt the bolometer to properly perform the functions of a receiving instrument for wireless-telegraph systems, it is necessary to so arrange the apparatus as to amplify the oscillatory current in the bolometer fine wire or strips, and means for accomplishing this end are diagrammatically illustrated in Figs. 2 and 3.

Having given reference to such printed publications as will serve to instruct those wishing

to construct and operate the bolometer as a means of detecting and measuring the oscillations which occur in wireless telegraphy, my invention may best be described by having reference to the drawings which accompany and form a part of this specification.

Similar letters of reference have, so far as may be, been employed to designate similar parts throughout the drawings of this specification.

Figure 1 illustrates diagrammatically the Rubens apparatus for detecting electrical oscillations. Fig. 2 illustrates a modification of the Rubens apparatus for detecting electrical oscillations especially adapting it to perform the functions of an electroreceptive device in a wireless-telegraph system. Fig. 3 illustrates an induction-balance operating upon the bolometer principle and having such modifications as to be especially adapted to operate as an electroreceptive device for wireless-telegraph systems.

V represents an elevated conductor, preferably vertically elevated. G represents a galvanometer or other suitable electric translating device. R and R' represent resistances. B represents a battery or other suitable source of current adapted to operate the electric translating device G. Thus if G be a galvanometer B must be a source of direct or unidirectional current, while if G be an electro-dynamometer B must be a source of either unidirectional or vibratory currents, and if G be a telephone B must be a source of rapidly-varying currents. D is a source of rapidly-varying currents.  $a a' a'' a'''$  and  $b b' b'' b'''$  are bolometer fine wires or strips adapted to be heated by the passage of a small current. E is an earth connection. T is a telephone-receiver. L is an inductance-coil. L' is a coil of inductance great as compared to the inductance of coil L. C is a condenser.

The operation of Fig. 1 is the same as that of the Rubens device. In the normal adjustment of the apparatus the branches B and G are conjugate, and there is therefore normally no current passing through G. Moreover, if we designate the resistance of the several conductors  $a a'$ , &c.,  $b b'$ , &c., by their letters of reference their normal adjustment is:  $a = a'$ ,  $a'' = a'''$ ,  $b = a$ ,  $b' = a'$ ,  $b'' = a''$ ,  $b''' = a'''$ . The preferred adjustment of the resistances of the branches  $a a'$ , &c.,  $b b'$ , &c., is:  $a = a' = a'' = a''' = b = b' = b'' = b'''$ , or, in other words, the resistances are all equal. In the reception of signals an oscillatory current is developed in the elevated conductor or oscillator V E, and this current passing through the bolometer fine wires or strips  $a a' a'' a'''$  cause a rise in temperature in these conductors. This rise in temperature in the conductors  $a a' a'' a'''$  causes a corresponding rise in resist-

ance of these conductors, and this rise in resistance unbalances the Christi balance or Wheatstone's bridge, of which these conductors form a part. A current is thereby caused to traverse the electric translating device G, which either indicates the passage of said current directly or by the closing of a local circuit adapted to operate a telegraphic sounder or recorder.

The organization shown in Fig. 2 is identical with that shown in Fig. 1 except that the bolometer fine wire or strips  $a' a'' a'''$  form part of a resonant circuit  $a' a'' a''' L L' C$  attuned to the frequency of the electromagnetic signal-waves to be received. By this means the oscillatory currents developed in the conductors  $a' a'' a'''$  are not only much amplified when the signal-waves are of the frequency to which the circuit  $a' a'' a''' L L' C$  is attuned, but the organization is rendered selective, so that it is more responsive or sensitive to waves of this particular frequency than waves of any other frequency.

The organization shown in Fig. 3 is given in this specification merely to illustrate how varied may be the forms of induction-balances or bridges employed without departing from the present invention. In this arrangement of the apparatus M is an induction-coil or transformer of which I and I' are two exactly equal primaries, forming, in fact, a continuous coil and having a terminal brought out at the neutral point  $o$ . By this construction the circuits containing the telephone-receiver T and generator D are normally rendered conjugate by making  $a = a' = a'' = a''' = b = b' = b'' = b'''$ . Under these circumstances no sound is heard in the telephone, but when signal-waves are received which correspond in frequency with the frequency to which the circuit  $a' a'' a''' a'' a' C L L'$  is made resonant the induction-balance is unbalanced and the telephone T gives forth a sound-signal.

It is obvious that B and G may interchange positions without affecting the operation of the organizations shown in Figs. 1 and 2, and it is also true that D and T may interchange positions in Fig. 3 without affecting the operation of the apparatus.

I do not claim herein an apparatus for receiving space-telegraph signals which utilizes in its operation the dissipative energy of the electric currents developed therein by electromagnetic signal-waves, such apparatus having been claimed in my application, Serial No. 119,211, filed August 11, 1902.

The special forms of bridges and induction-balances which may be used for the purpose and in the manner hereinbefore described are very great, and some of these forms are well known in the arts. I therefore wish it to be particularly understood that I do not restrict myself to any special form of bridge or balance or mode of associating a bolometer fine

wire or strip with such bridge or balance; but

I claim, broadly, as my invention—

1. The method of receiving wireless or space telegraph signals, which consists in receiving the energy of the electromagnetic signal-waves in an elevated conductor, conveying said energy to a resonant circuit including the fine wire or strip of a bolometer and attuned to the frequency of the signal-waves to be received, converting said energy into thermal energy, thereby varying the resistance of said fine wire or strip, and producing intelligible signals by such resistance variation.

2. The method of receiving wireless or space telegraph signals, which consists in receiving the energy of the signal-waves in an elevated conductor, conveying said energy to a resonant circuit including a fine wire or strip of small thermal time constant forming the variable resistance of a bolometer, converting said energy into thermal energy, thereby varying the resistance of said fine wire or strip of small thermal time constant, and producing intelligible signals by such resistance variation.

3. The method of receiving space-telegraph signals, which consists in receiving the energy of electromagnetic signal-waves in an elevated conductor, conveying or translating the energy of the resulting electric oscillations to a closed resonant circuit attuned to the frequency of the transmitted waves, converting the energy of the electric oscillations developed in said resonant circuit into thermal energy and thereby producing intelligible signals in a suitable indicating device.

4. The method of receiving space-telegraph signals, which consists in receiving the energy of electromagnetic signal-waves in an elevated conductor, conveying or translating the energy of the resulting electric oscillations to a closed resonant circuit attuned to the frequency of the transmitted waves, changing the resistance of a conductor or a plurality of conductors of small thermal time constant included in said resonant circuit by the energy of the electric oscillations developed in said resonant circuit and thereby producing intelligible signals in a suitable indicating device.

5. The method of receiving space-telegraph signals, which consists in receiving the energy of electromagnetic signal-waves in an elevated conductor, amplifying the resulting electric oscillations by means of a closed resonant circuit attuned to the frequency of the transmitted waves, and utilizing the dissipative energy of the amplified oscillations to thereby produce intelligible signals.

6. The method of receiving space-telegraph signals, which consists in receiving the energy of electromagnetic signal-waves in an elevated conductor and causing the resulting electric oscillations to change the thermal condition of

a member of small thermal time constant to thereby produce intelligible signals in a suitable indicating device.

7. The method herein described of receiving space-telegraph signals, which consists in receiving the energy of the electromagnetic signal-waves in an elevated conductor and utilizing the dissipative energy of the resulting electric oscillations to effect a change in the condition of a member of small thermal time constant to thereby produce intelligible signals in a suitable indicating device.

8. The method of receiving space-telegraph signals, which consists in absorbing the energy of electromagnetic signal-waves by an elevated conductor and changing the temperature and resistance of a sensitive element of small mass, small specific heat and imperfect heat insulation by the energy of the resulting electric oscillations to thereby produce intelligible signal indications in a suitable indicating device.

9. The method of receiving space-telegraph signals which consists in receiving the energy of electromagnetic signal-waves in an elevated conductor, amplifying the resulting electrical oscillations by means of a resonant circuit attuned to the frequency of the transmitted waves, and utilizing the dissipative energy of the amplified electrical oscillations to produce intelligible signals.

10. The method of receiving space-telegraph signals which consists in receiving the energy of electromagnetic signal-waves in an elevated conductor, amplifying the resulting electrical oscillations by means of a circuit attuned by capacity and inductance to the frequency of the transmitted waves and utilizing the dissipative energy of the amplified electrical oscillations to produce intelligible signals.

11. The method of receiving space-telegraph signals which consists in receiving the energy of electromagnetic signal-waves in an elevated conductor, thereby creating electrical oscillations in said elevated conductor, converting the energy of said electrical oscillations into thermal energy and thereby producing intelligible signals in a suitable indicating device.

12. The method of receiving space-telegraph signals which consists in receiving the energy of electromagnetic signal-waves in an elevated conductor, thereby creating electrical oscillations in said elevated conductor, utilizing the dissipative energy of said electrical oscillations to vary the condition of a sensitive element and thereby producing intelligible signals.

13. The method of receiving space-telegraph signals which consists in receiving the energy of electromagnetic signal-waves in an elevated conductor, thereby creating electrical oscillations in said elevated conductor, utilizing the dissipative energy of said electrical oscillations to effect a change in the thermal condition of a sensitive element and thereby producing intelligible signals.

14. As an improvement in the art of receiving space-telegraph signals the method herein described of utilizing the dissipative energy of the electrical oscillations developed in a space-telegraph receiving system to vary the thermal condition of a sensitive element and thereby producing intelligible signals in a suitable indicating device.

15. As an improvement in the art of receiving space-telegraph signals the method herein described which consists in converting the energy of the electrical oscillations developed in a space-telegraph receiving system into thermal energy and thereby producing intelligible signals in a suitable indicating device.

16. In the method herein described of receiving the energy of electromagnetic signal-waves, the step which consists in converting the energy of the electrical oscillations or oscillatory electric currents resulting from electromagnetic waves into thermal energy.

17. As an improvement in the art of receiving space-telegraph signals the method herein described which consists in absorbing the energy of electromagnetic waves, converting the energy of the resulting electrical oscillations or oscillatory electric currents into thermal energy and thereby producing intelligible signals.

18. As an improvement in the art of receiving space-telegraph signals the method herein described which consists in absorbing the energy of electromagnetic waves, changing or modifying by the dissipative energy of the resulting electrical oscillations the normal condition of a body of conducting matter and thereby producing intelligible signals.

19. As an improvement in the art of receiving space-telegraph signals the method herein described which consists in changing or modifying the normal condition of a conducting body of small mass and small specific heat by the energy of electromagnetic signal-waves and thereby producing intelligible signals.

20. As an improvement in the art of receiving space-telegraph signals the method herein described which consists in changing the normal condition of a homogeneous body of conducting matter by electric currents resulting from electromagnetic signal-waves and thereby producing intelligible signals.

21. The method of receiving space-telegraph signals which consists in absorbing the energy of electromagnetic signal-waves, converting the energy of said waves into thermal energy, and thereby effecting the production of intelligible signals.

In testimony whereof I have hereunto subscribed my name this 9th day of September, 1902.

JOHN STONE STONE.

Witnesses:

ALEX. P. BROWNE,  
ELLEN B. TOMLINSON.