

A. A. BAKER.
GRINDING MACHINE.
APPLICATION FILED NOV. 28, 1902.

NO MODEL.

2 SHEETS—SHEET 1.

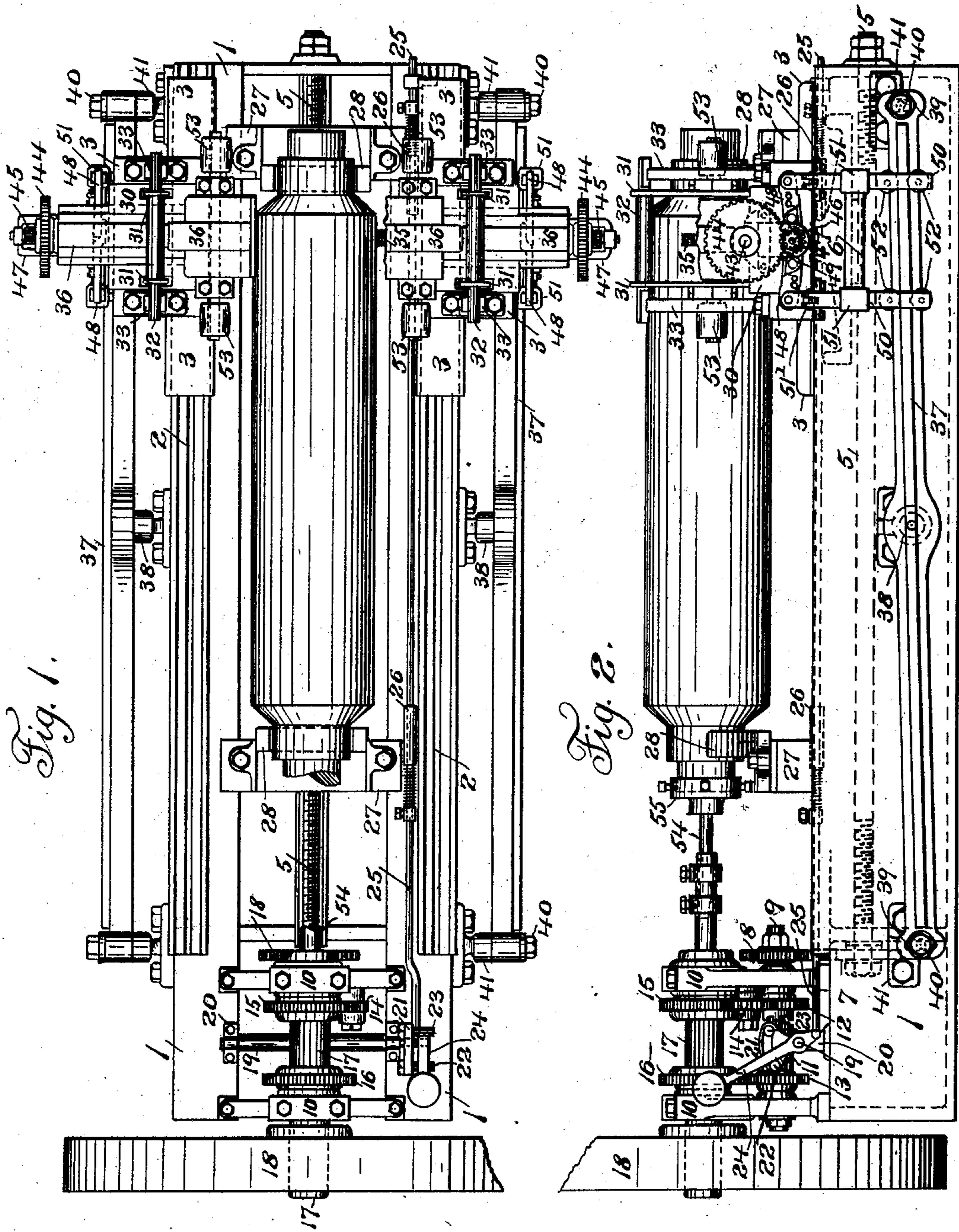

Fig. 1.

Fig. 2.

ATTEST:

A. White
Witness

INVENTOR:

Albert A. Baker
by *Phillips, Seaman, Rice & Kennedy*
ATTYS.

A. A. BAKER.
GRINDING MACHINE.
APPLICATION FILED NOV. 28, 1902.

NO MODEL.

2 SHEETS—SHEET 2.

Fig. 3.

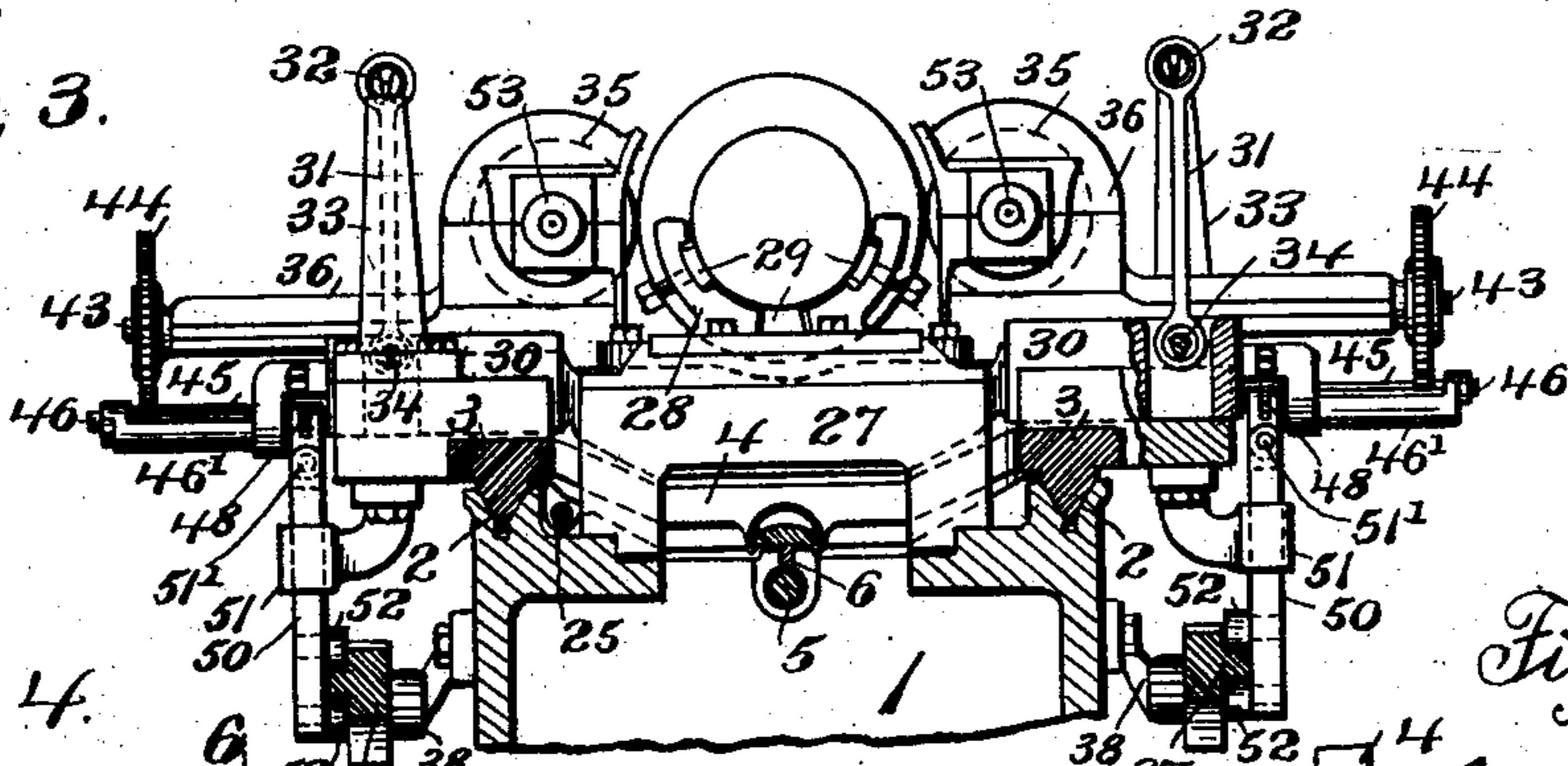

Fig. 4.

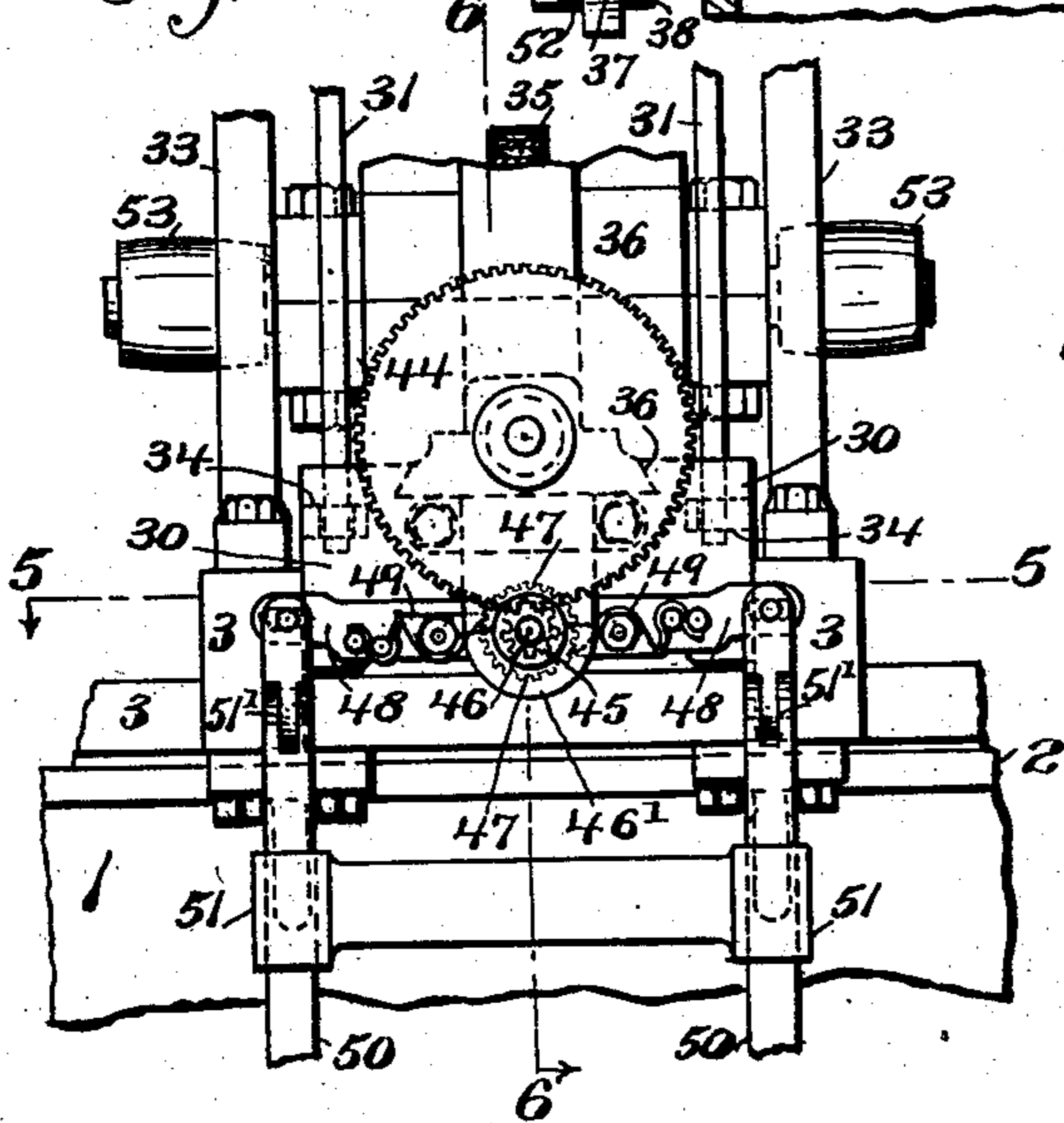

Fig. 5.

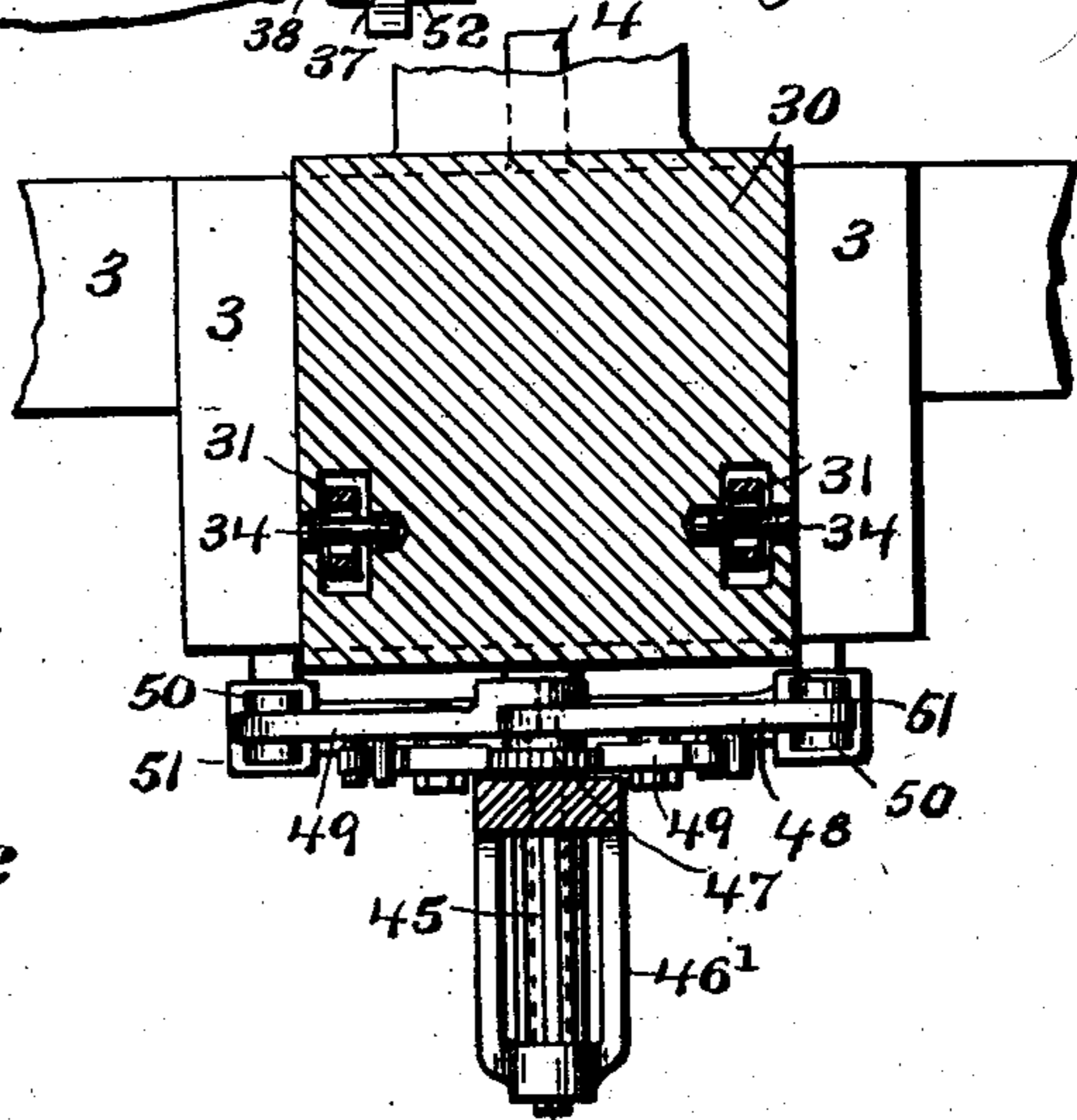
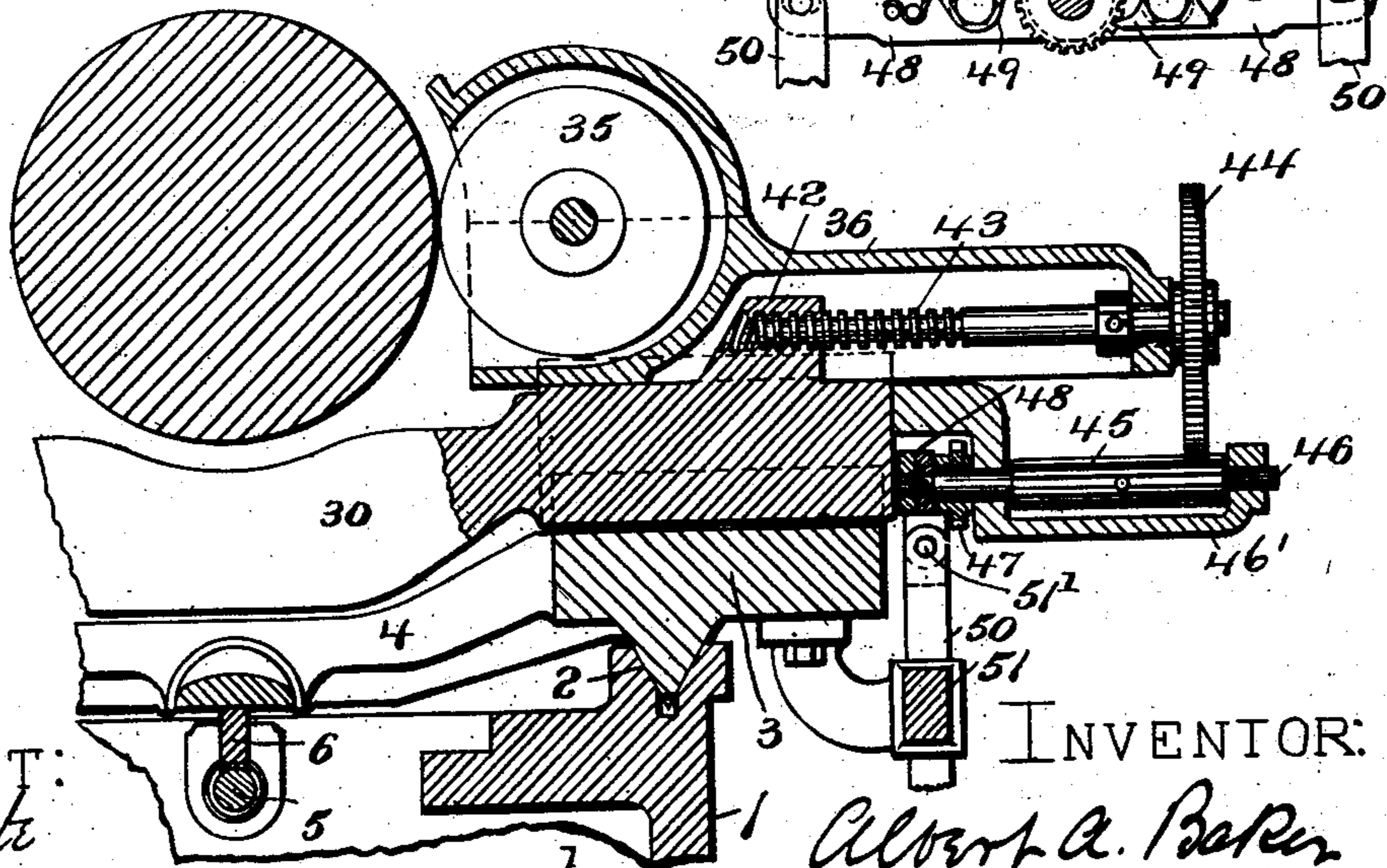

Fig. 6.



ATTEST:
A. White
W. H. Keenan

INVENTOR:
Albert A. Baker
by Philip S. Sawyer, Perc. H. Kennedy
ATTYS.

UNITED STATES PATENT OFFICE.

ALBERT A. BAKER, OF ANSONIA, CONNECTICUT, ASSIGNOR TO FARRELL
FOUNDRY AND MACHINE COMPANY, OF ANSONIA, CONNECTICUT, A
CORPORATION OF CONNECTICUT.

GRINDING-MACHINE.

SPECIFICATION forming part of Letters Patent No. 747,924, dated December 29, 1903.

Application filed November 28, 1902. Serial No. 133,078. (No model.)

To all whom it may concern:

Be it known that I, ALBERT A. BAKER, a
citizen of the United States, residing at An-
sonia, county of New Haven, and State of Con-
necticut, have invented certain new and use-
ful Improvements in Grinding - Machines,
fully described and represented in the fol-
lowing specification and the accompanying
drawings, forming a part of the same.

This invention relates to certain improve-
ments in grinding-machines.

In grinding-machines as now usually con-
structed, and more especially in those ma-
chines used for grinding rolls or similar work
in which it is necessary to produce a relative
lengthwise traveling movement between the
work and the grinding device or devices,
these devices are mounted on an adjustable
support, which is in turn mounted on a trav-
eling carriage. An attendant adjusts the
grinding devices at the beginning of the move-
ment of the carriage, giving the grinding de-
vices as strong a cut as is possible. As the
carriage travels along the work, however, the
grinding devices wear away. It follows, there-
fore, particularly in grinding long rolls, that
the grinding devices are not doing the proper
amount of cutting toward the end of the move-
ment of the carriage in each direction, since
while these devices produce a comparatively
deep cut at the beginning of the stroke the
cut decreases as the travel of the carriage
proceeds. The attendant is supposed to give
the grinding devices such an adjustment at
the beginning of each stroke as to cause them
to produce a cut which is deep enough to com-
pensate for the lightness of the cut at the end
of the preceding stroke. To give the proper
adjustment of the wheels or other grinding
devices to produce this compensating cut is
an exceedingly difficult matter and requires
great experience, and, furthermore, in grind-
ing work—such, for instance, as long cylin-
ders—since the cut is deeper as the grinding-
rolls begin their cut than it is toward the cen-
ter of the stroke of the carriage it follows that
a roll is apt to be ground so that it will be of
greater diameter in the center than at the
ends. This makes it necessary to shorten the
stroke of the carriage and subject the center

of the roll to a separate operation in order to
bring the diameter of it down to the diameter
of the ends. Inasmuch as many rolls neces-
sarily have to be ground within a ten-thou-
sandth of an inch the proper adjustment of
the grinding devices to produce this separate
grinding operation at the center of the roll is
exceedingly delicate.

It is the object of this invention to produce
an improved grinding mechanism in which
there is a relative movement between the
work and the grinding devices in order to
present fresh parts of the work to said de-
vices and in which an automatic feeding
movement is produced between the grinding
devices and the work to compensate for the
wear of the grinding devices.

A further object of the invention is to pro-
duce a grinding mechanism in which there is
a relative movement between the work and
the grinding devices in order to present fresh
parts of the work to the grinding devices and
in which a relative feeding movement is pro-
duced between the grinding devices and the
work during the grinding operation to enable
said devices to effect a uniform cut during
the entire length of the work-presenting
movement.

With these and other objects in view the
invention consists in certain constructions
and in certain parts, improvements, and com-
binations, as will be hereinafter fully de-
scribed and then specifically pointed out in
the claims hereunto appended.

In the accompanying drawings, Figure 1
is a plan view of the machine embodying the
invention. Fig. 2 is a side elevation of the
machine shown in Fig. 1. Fig. 3 is an end
elevation, partly in section. Fig. 4 is a de-
tail view, on a large scale, illustrating a part
of the feeding means for the grinding de-
vices. Fig. 5 is a section on the line 5 5 of
Fig. 4. Fig. 6 is a detail sectional elevation
on the line 6 6 of Fig. 4. Fig. 7 is a detail
view illustrating the construction of the pawl-
carriers.

In the drawings, which illustrate a pre-
ferred embodiment of the invention, 1 indi-
cates a supporting-bed. The bed is provided
with ways 2, in which is mounted a carriage,

said carriage comprising blocks 3, connected by a cross-web 4. This carriage is a traveling carriage, and in the construction shown it is arranged to reciprocate.

5 The means for reciprocating the carriage may be of any preferred construction. As shown, the bed supports a feed-screw 5, which is engaged by a feeding-nut 6, secured to the cross-web 4. The feed-screw is provided at one end (see dotted lines in Fig. 2) with a gear-wheel 7, which is in mesh with a gear 8, mounted on a short shaft 9, suitably supported in standards 10, rising from the bed. This short shaft is provided with a clutch-collar 11, which is splined on the shaft and is arranged to engage the hubs of either of the two gears 12 13, which are loosely mounted on the shaft. The gear 12 is in engagement with an intermediate 14, mounted on a stud projecting from one of the bearings 10, said intermediate being in engagement with a gear 15. The gear 13 is in direct engagement with a gear 16. The gears 15 and 16 are mounted on a short shaft 17, which is supported in suitable bearings in the standards 10. This shaft 17 has on its end a driving-pulley 18, although it may be driven in any other suitable manner. The shaft 17 always runs in the same direction; but it is apparent that the feed-screw will be rotated first in one direction and then in the other, according to whether the collar 11 is in engagement with the gear 12 or the gear 13.

35 The means for controlling the position of the clutch-collar may be of any suitable description. As shown, there is provided a short shaft 19, located in bearings 20, mounted on the bed, this shaft carrying a quadrant 21, which is fast on the shaft, said quadrant serving to support pins 22 and 23. Loosely mounted on the shaft 19 is a ball-lever 24, to one arm of which is connected a sliding rod 25. This rod passes through a perforation in the carriage (see Fig. 3) and is provided with two sliding collars 26, backed up by springs, as shown. As the carriage completes its movement in each direction it strikes one of the collars 26 and shifts the rod. This operates the ball-lever, which is thrown against one or the other of the pins 22 23, thus rocking the quadrant on the shaft 19. There is a pin connection between the quadrant and the clutch-collar, which is not shown, so that the movement of the quadrant slides the collar and causes it to engage with either one or the other of the hubs of the gears 12 13. The clutch which has just been described is a well-known construction, and any other suitable form of clutch mechanism may be substituted for it.

60 The machine is provided with a suitable work-support and with suitable means for supporting a grinding device or devices, and the construction is of course such that fresh parts of the work are being presented to the grinding devices during the grinding operation. The construction by which the work

is supported and the grinding devices are mounted so as to effect this presentation of the work to the grinding mechanism will vary according to the type or construction of the machine employed. In a machine of the type shown in the drawings, in which a reciprocating carriage is employed, either the work-support or the grinding-device support supports may be mounted on the carriage, so that a traversing movement may be effected between the work and the grinding devices. Furthermore, the construction by which the supports which are mounted on the carriage are connected to the carriage is preferably of such a description as to permit an adjustment between the carriage and the said support to compensate for inequalities.

85 In the construction shown the grinding devices are mounted on the carriage and the work-support is mounted on the bed. This work-support, which may be of any suitable character, consists of a pair of cross-bars 27, which are bolted to the bed, and since the machine which has been selected to illustrate the invention is intended for grinding rolls, these supports also are provided with bearings 28, in which the roll rests. These bearings are preferably provided with adjusting-blocks 29, as is common in such constructions, so that the roll may be trued up in the bearings.

100 The means for supporting the grinding devices may be of any suitable description and will vary according to the construction of the machine in which the invention is embodied and according to the number and nature of the grinding devices employed. It has been before stated that the construction by which the grinding device or devices are mounted on the carriage is of such a character as to permit a compensating adjustment between the grinding device or devices and the carriage, and it may be further remarked that this construction also may be varied according to the particular machine in which the invention is embodied. As shown, there is provided a block 30, which extends across the side of the machine by pairs of hangers 31. The hangers 31 are supported at their upper ends by cross-bars 32, said cross-bars being provided on their ends with knife-edges which engage suitably-formed recesses in the tops of standards 33, rising from the blocks 3, which form part of the carriage. These hangers 31 at their lower ends engage short knife-edge bearings 34, (see Fig. 5,) mounted in recesses in the block 30. By this construction the block 30 is enabled to have a swinging movement which permits the compensating adjustment before referred to.

130 The grinding devices, which, as shown, consist of wheels 35, may be mounted in any suitable manner. In the construction shown the machine is provided with sliding heads 36, in which the wheels are mounted, there being in the type of machine which has been selected

to illustrate this invention two of these heads, one located on each side of the work. These heads are supported on the block 30 and preferably move in ways therein. The means for effecting the feeding movement of the sliding heads may be widely varied and will be varied according to the type of machine in which the invention is embodied. In the preferred form of the construction a controller will be employed which may also be of any suitable construction. As shown, the controller consists of an inclined bar 37, and since the machine which has been selected to illustrate the invention employs two grinding devices there will preferably be two of these bars, one on each side of the machine. These bars may be mounted in any suitable manner. In the construction shown these bars are pivoted on brackets 38, which are secured to the sides of the bed. In the preferred form of the construction the bars will be so mounted as to enable them to be adjustable, so as to produce different depths of cut. As shown, this adjustment is effected by providing each end of each bar with a slot 39, which is engaged by a screw 40, which is tapped into a bracket 41, secured to the bed.

The connections by which the controllers produce the feeding movement of the heads will be varied according to the type of the controller and the construction of the heads. As shown, the block 30 on each side is provided with a threaded boss 42, which is engaged by a feeding-screw 43, journaled in an extension of the head. The outer end of each feed-screw is provided with a gear 44, which engages with a long pinion 45, supported on a shaft 46, journaled in a bracket 46'. The inner ends of these shafts 46 are provided with ratchet-wheels 47, and each shaft has mounted thereon a pair of pawl-carriers 48, whose pawls 49 face in opposite directions. Suitable connections are provided by which the pawl-carriers are operated from the controllers, these connections being preferably of such a character that one of the pawls will be operated on one stroke of the reciprocating carriage and the other pawl will be operated on the other stroke of the reciprocating carriage. Furthermore, these connections are preferably flexible, so as to allow for the compensating adjusting movement heretofore referred to as taking place between the carriage and the sliding heads through the medium of the swinging block 30. In the construction shown each controller-bar is engaged by a pair of jointed sliding rods 50, which move in guides 51, secured to the machine-bed. The upper ends of these rods are pivoted at 51' to the pawl-carriers, and their lower ends are provided with wheels 52, which engage on opposite sides of ribs on the controller-bars.

The grinding-wheels may be driven in any suitable manner. As shown, each of the shafts on which these wheels are mounted are

provided with driving-pulleys 53, around which belts are passed in the usual manner.

With the construction as before described it will be understood that as the carriage is reciprocated in one direction one of the sliding rods of each pair operates its corresponding pawl-carrier to turn the ratchet-wheels 47, thus feeding the heads carrying the grinding devices toward the work and amount of feed being controlled by the amount of inclination of the controller-bar. On the return stroke of the carriage the other sliding rod of each pair operates to turn the ratchet-wheel in the same direction, thus continuing the feeding movement of the head toward the work. It is obvious that the feeding movement is entirely automatic and that by properly adjusting the controller-bars the wearing away of the grinding-wheels during the grinding operation can be compensated for so that the wheels are enabled to produce a uniform cut.

When the machine is employed for grinding rolls, the rolls will be rotated during the grinding operation by means of a spindle 54, said spindle being provided with a cap 55 of the usual construction. This spindle 54 is or may be made in two parts to enable it to be adjustable and is rotated from the shaft 17.

It will be understood that while the machine shown embodies a preferred form of the invention the invention may be embodied in machines which are widely different in construction and operation. The invention is not therefore to be limited to the specific construction which has been hereinbefore described.

What is claimed is—

1. In a grinding-machine, the combination with a work-support, of means for supporting the grinding device, means for causing fresh parts of the work to be presented to the grinding device, and automatic means for producing a uniform advancing feeding movement between the work and the grinding device during the grinding operation to compensate for the wear of the grinding device, substantially as described.

2. In a grinding-machine, the combination with a work-support, of means for supporting the grinding device, means for causing fresh parts of the work to be presented to the grinding device, and automatic means for feeding the grinding device uniformly toward the work during the grinding operation to compensate for the wear of the grinding device, substantially as described.

3. In a grinding-machine, the combination with a work-support, of a grinding device, means for causing fresh parts of the work to be presented to the grinding device, a feed-controller for positively feeding the grinding device uniformly toward the work to compensate for the wear of the grinding device, and means for producing a relative traveling movement between the controller and the

grinding device during the grinding operation, substantially as described.

4. In a grinding-machine, the combination with a work-support, of a grinding-wheel, a carrier in which the wheel is mounted, means for reciprocating the carrier along the work, and means for positively and automatically feeding the wheel uniformly toward the work to compensate for the wear of the grinding device, substantially as described.

5. In a grinding-machine, the combination with a work-support, of grinding devices operating on opposite sides of the work, means for causing fresh parts of the work to be presented to the grinding devices, and automatic means for feeding the grinding devices toward the work, substantially as described.

6. In a grinding-machine, the combination with a work-support, of grinding devices operating on opposite sides of the work, means for causing fresh parts of the work to be presented to the grinding devices, and automatic means for feeding the grinding devices toward the work during the grinding operation, substantially as described.

7. In a grinding-machine, the combination with a traveling carriage, of means for supporting the work, means for supporting a grinding device, one of said supporting means being mounted on the carriage, means for permitting an adjustment between the carriage and the supporting means mounted thereon, and automatic means for producing a relative feeding movement between the work and the grinding devices, substantially as described.

8. In a grinding-machine, the combination with a traveling carriage, of means for supporting the work, means for supporting a grinding device, one of said supporting means being mounted on the carriage, means for permitting an adjustment between the carriage and the supporting means mounted thereon, and automatic means for producing a relative feeding movement between the work and the grinding devices during the grinding operation, substantially as described.

9. In a grinding-machine, the combination with a traveling carriage, of a work-support, grinding devices operating on opposite sides of the work, said devices being mounted on the carriage, means for permitting an adjustment between the grinding devices and the carriage, and means for automatically feeding the grinding devices toward the work, substantially as described.

10. In a grinding-machine, the combination with a traveling carriage, of a work-support, grinding devices operating on opposite sides of the work, said devices being mounted on the carriage, means for permitting an adjustment between the grinding devices and the carriage, and means for automatically feeding the grinding devices toward the work during the grinding operation, substantially as described.

11. In a grinding-machine, the combination with a work-support, of means for supporting the grinding device, means for producing a relative movement between the work and the grinding device whereby fresh parts of the work are presented to the grinding device, a controller, and connections whereby the controller produces an automatic feeding movement between the work and the grinding devices during the grinding operation, substantially as described.

12. In a grinding-machine, the combination with a work-support, of grinding devices operating on opposite sides of the work, means for producing a relative movement between the work and the grinding devices whereby fresh parts of the work are presented to the grinding devices, controllers for said grinding devices, and connections between each controller and its grinding device whereby the controllers feed the grinding devices toward the work during the grinding operation, substantially as described.

13. In a grinding-machine, the combination with a bed, of a traveling carriage mounted thereon, means for supporting the work and means for supporting the grinding devices, one of said supporting means being mounted on the carriage, means for permitting an adjustment between the carriage and the supporting means mounted thereon, a controller, and means including flexible connections between the controller and the supporting means on the carriage, whereby the controller produces an automatic feeding movement between the work and the grinding devices during the feeding operation, substantially as described.

14. In a grinding-machine, the combination with a bed, of a traveling carriage, means on the carriage for supporting the grinding devices, said means permitting an adjustment between the carriage and said grinding devices, a controller mounted on the bed, and means including flexible connections between the controller and the grinding-device-supporting means, whereby the grinding devices are automatically fed toward the work during the grinding operation, substantially as described.

15. In a grinding-machine, the combination with a bed, of a traveling carriage, work-supporting means, grinding devices operating on opposite sides of the work, means for supporting the grinding devices on the carriage, said means being constructed to permit an adjustment between the carriage and said grinding devices, controllers mounted on the bed, and means including flexible connections between the controllers and the grinding devices whereby the grinding devices are fed toward the work during the grinding operation, substantially as described.

16. In a grinding-machine, the combination with a bed, of a work-support, a traveling carriage, a grinding device supported thereon, a controller-bar, and connections between the

controller-bar and the grinding device whereby the controller-bar feeds the grinding device toward the work during the grinding operation, substantially as described.

5 17. In a grinding-machine, the combination with a reciprocating carriage, of a work-support, a grinding device mounted on the carriage, a controller, and connections between the controller and the grinding device where-
10 by the grinding device is fed toward the work on each stroke of the carriage, substantially as described.

15 18. In a grinding-machine, the combination with a traveling carriage, of grinding devices operating on opposite sides of the work, sliding heads mounted in the carriage on which the grinding devices are supported, controller-bars, and connections including suitable gearing between the bars and the heads,
20 whereby the sliding heads carrying the grinding devices are fed toward the work during the grinding operation, substantially as described.

25 19. In a grinding-machine, the combination with a bed, of a reciprocating carriage, a work-support, sliding heads mounted in the carriage and located on opposite sides of the work-support, grinding devices supported in the heads, a pair of controller-bars located
30 on opposite sides of the bed, and connections between each controller-bar and its corresponding head whereby the heads and the grinding devices mounted thereon are fed toward the work during each stroke of the
35 carriage, substantially as described.

40 20. In a grinding-machine, the combination with a bed, of a reciprocating carriage, a grinding device mounted in the carriage, a controller, and means including two sets of connections for feeding the grinding device toward the work during the grinding operation, one set of connections being operative on one stroke of the carriage and the other set being operative on the other stroke of the
45 carriage, substantially as described.

50 21. In a grinding-machine, the combination with a bed, of a traveling carriage, work-supporting means and grinding-device-supporting means, one of said means being mounted on the carriage, an inclined controller-bar, and connections between the controller-bar and the supporting means mounted on the carriage whereby a relative feeding movement is produced between the work and the
55 grinding device during the grinding operation, substantially as described.

60 22. In a grinding-machine, the combination with a bed, of a traveling carriage, work-supporting means and grinding-device-supporting means, one of said means being mounted on the carriage, an inclined controller-bar, means for adjusting the inclination of the bar, and connections between the controller-bar and the supporting means mounted on the carriage whereby a relative feeding movement is produced between the work and the

grinding device during the grinding operation, substantially as described.

23. In a grinding-machine, the combination with a reciprocating carriage, work-supporting means and grinding-device-supporting means, one of said means being mounted on the carriage, a controller-bar, and means including two sets of connections for producing a relative feeding movement between the
70 grinding-device-supporting means and the work-supporting means, one of said sets of connections being operative on each stroke of the carriage, substantially as described. 75

24. In a grinding-machine, the combination with a traveling carriage, of a work-support, grinding devices operating on opposite sides of the work, means for supporting said grinding devices on the carriage, said supporting means permitting an adjustment between
80 the grinding devices and the carriage, an inclined controller-bar for each grinding device, means including flexible connections between each controller-bar and the corresponding device, supporting means whereby
85 the controller-bars feed the grinding devices toward the work during the grinding operation, and means for adjusting the inclination of the controller-bars, substantially as described. 95

25. In a grinding-machine, the combination with a bed, of a work-support mounted thereon, a carriage, means for reciprocating the carriage on the bed, grinding-device-supporting heads mounted on opposite sides of the
100 work, controller-bars, feeding devices operating on the supporting-heads, and two sets of connections between each feeding device and its controller-bar, whereby the controller-bars feed the supporting-heads toward
105 the work during the grinding operation, one set of connections being operative on each stroke of the carriage, substantially as described.

26. In a grinding-machine, the combination with a bed, of a work-support mounted thereon, a carriage, means for reciprocating the carriage on the bed, grinding-device-supporting heads mounted on opposite sides of the
110 work, inclined controller-bars, means for adjusting the inclination of the bars, feeding devices operating on the supporting-heads, and two sets of connections between each feeding device and its controller-bar, whereby the controller-bars feed the supporting-
115 heads toward the work during the grinding operation, one set of connections being operative on each stroke of the carriage, substantially as described. 120

27. In a grinding-machine, the combination with a bed, of a work-support mounted thereon, a carriage, means for reciprocating the carriage, heads for supporting the grinding devices mounted on the carriage and located on opposite sides of the work, a controller-
125 bar for each head, a ratchet-wheel for each head, means whereby the ratchet-wheels pro- 130

duce a feeding movement of the heads, a pair of pawl-carriers for each ratchet-wheel whose pawls face in opposite directions, and two pawl-carrier-operating rods said rods being
5 in engagement with the controller-bars of their respective heads, substantially as described.

28. In a grinding-machine, the combination with a bed, of a work-support mounted thereon, a carriage, means for reciprocating the carriage, heads for supporting the grinding devices mounted on the carriage and located on opposite sides of the work, an inclined controller-bar for each head, means for adjusting the inclination of the bars, a ratchet-wheel for each head, means whereby the ratchet-wheels produce a feeding movement of the heads, a pair of pawl-carriers for each ratchet-wheel whose pawls face in opposite
20 directions, and two pawl-carrier-operating rods said rods being in engagement with the controller-bars of their respective heads, substantially as described.

29. In a grinding-machine, the combination with a bed, of a work-support, a carriage, means for reciprocating the carriage on the bed, sliding heads for supporting the grinding devices located on opposite sides of the work, means for supporting said heads on the carriage, said supporting means being constructed to permit an adjustment between the heads and the carriage, feeding devices for moving each head toward the work, a ratchet-wheel for operating each feeding device, a pair of pawl-carriers whose pawls face in opposite directions cooperating with each of said ratchet-wheels, a pair of controller-bars one for each head located on opposite sides of the bed, sliding rods for each pawl-carrier said rods being flexibly connected to said pawl-carriers and being in engagement with the controller-bars, substantially as described.

30. In a grinding-machine, the combination with a bed, of a work-support, a carriage, means for reciprocating the carriage on the bed, sliding heads for supporting the grinding devices located on opposite sides of the work, means for supporting said heads on the carriage, said supporting means being constructed to permit an adjustment between the heads and the carriage, feeding devices for moving each head toward the work, a ratchet-wheel for operating each feeding device, a pair of pawl-carriers whose pawls face in opposite directions cooperating with each of said ratchet-wheels, a pair of inclined controller-bars one for each head located on opposite sides of the bed, means for adjusting

the inclination of the bars, and sliding rods for each pawl-carrier said rods being flexibly connected to said pawl-carriers and being in engagement with the controller-bars, substantially as described.

31. In a grinding-machine, the combination with a bed, of a work-support, a reciprocating carriage, a swinging block mounted on the carriage, grinding devices mounted on the block and operating on opposite sides of the work, and means for feeding the grinding devices toward the work during the grinding operation, substantially as described.

32. In a grinding-machine, the combination with a bed, of a work-support, a reciprocating carriage, a swinging block mounted on the carriage, sliding heads mounted in the block and located on opposite sides of the work, grinding-wheels mounted in the heads, controller-bars for feeding the heads toward the work during the grinding operation, and flexible connections between the controller-bars and the heads, substantially as described.

33. In a grinding-machine, the combination with a bed, of a work-support, a reciprocating carriage mounted thereon, a swinging block mounted on the carriage, sliding heads mounted in the block and located on opposite sides of the work, feed-screws for moving the heads toward the work, gearing for operating the screws, controller-bars mounted on the bed, and means flexibly connected with the controller-bars for operating the gearing to feed the heads toward the work during the grinding operation, substantially as described.

34. In a grinding-machine, the combination with a bed, of a work-support, a reciprocating carriage mounted thereon, a swinging block mounted on the carriage, sliding heads mounted in the block and located on opposite sides of the work, feed-screws for moving the heads toward the work, gearing including a ratchet-wheel for each head, a pair of pawl-carriers for each ratchet-wheel whose pawls face in opposite directions, inclined controller-bars, means for adjusting the inclination of the bars, and sliding operating-bars in engagement with the controller-bars for operating the pawl-carriers, said rods being flexibly connected to the pawl-carriers, substantially as described.

In testimony whereof I have hereunto set my hand in the presence of two subscribing witnesses.

ALBERT A. BAKER.

Witnesses:

ALTON FARREL,
CHARLES F. BLIN.