

J. M. BROWNING.
RECOIL OPERATED FIREARM.

(Application filed Mar. 18, 1901.)

(No Model.)

4 Sheets—Sheet 1.

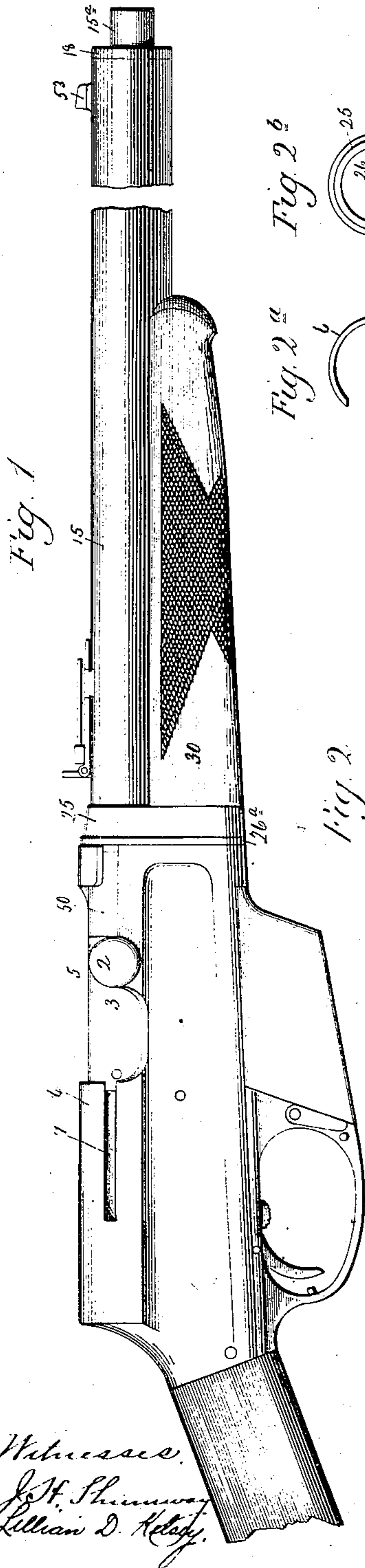

Witnesses,
 J. H. Shinnaway
 William D. Kellogg.

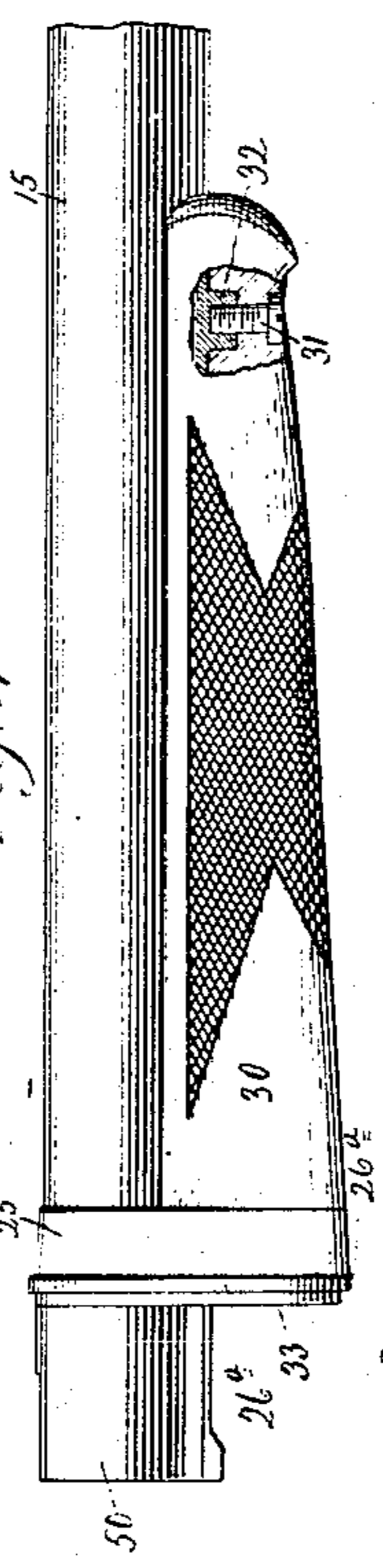
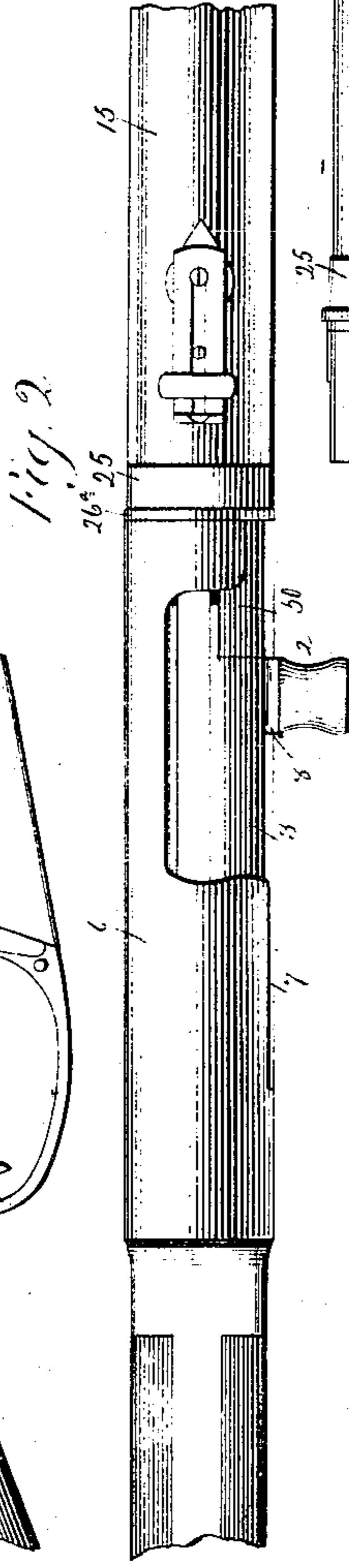
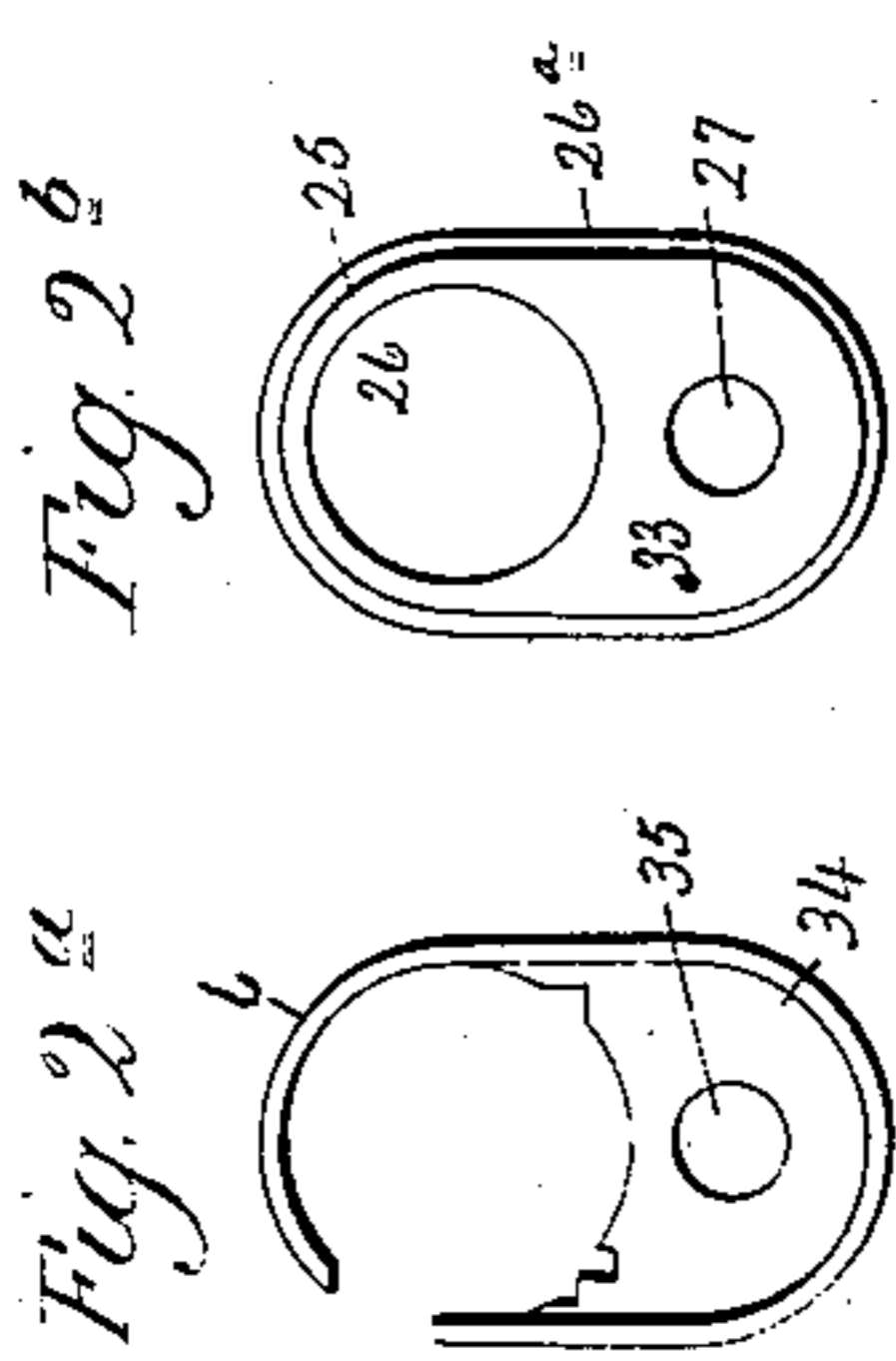
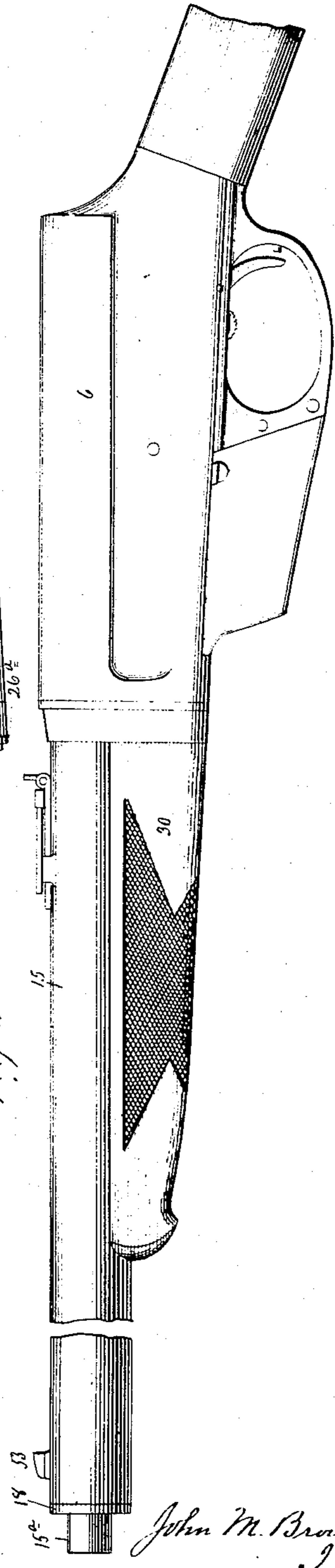

Fig. 3



John M. Browning
 Inventor.
 By Atty. Seymour & Carr

J. M. BROWNING.
RECOIL OPERATED FIREARM.

(Application filed Mar. 18, 1901.)

(No Model.)

4 Sheets—Sheet 2.

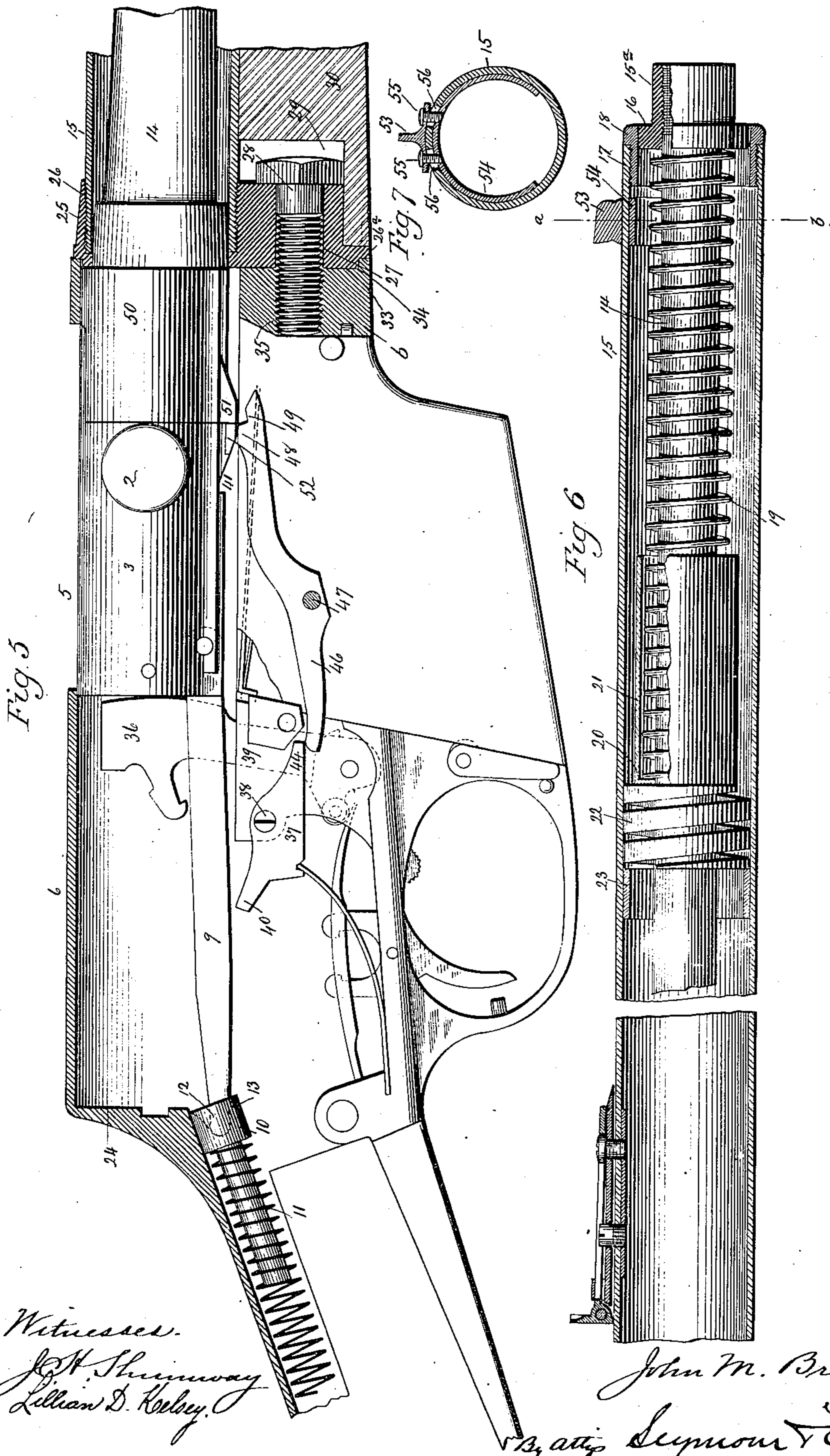

Witnesses:
J. H. Shimway
Lillian D. Kelby

John M. Browning
 Inventor
Seymour T. Carr
 Attorney

No. 701,288.

Patented June 3, 1902.

J. M. BROWNING.
RECOIL OPERATED FIREARM.

(Application filed Mar. 18, 1901.)

(No Model.)

4 Sheets—Sheet 3.

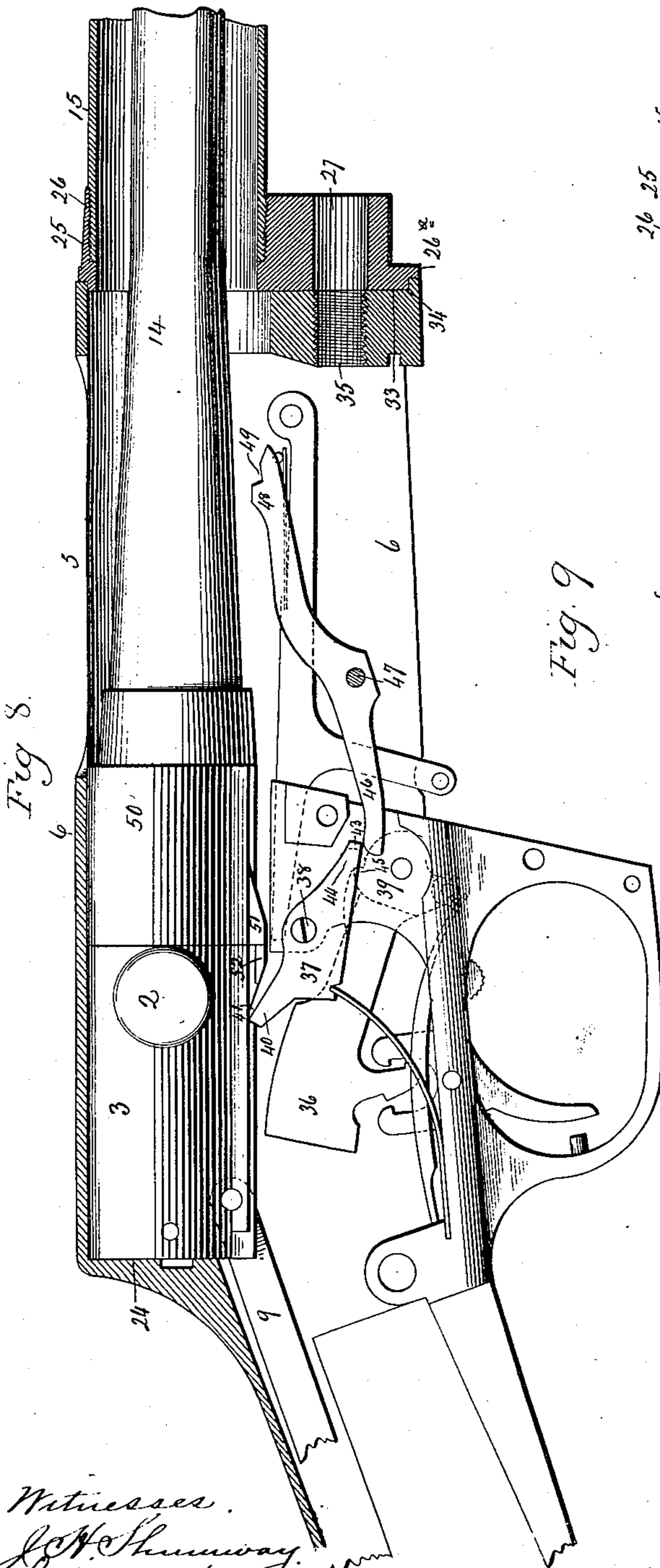

Fig. 8.

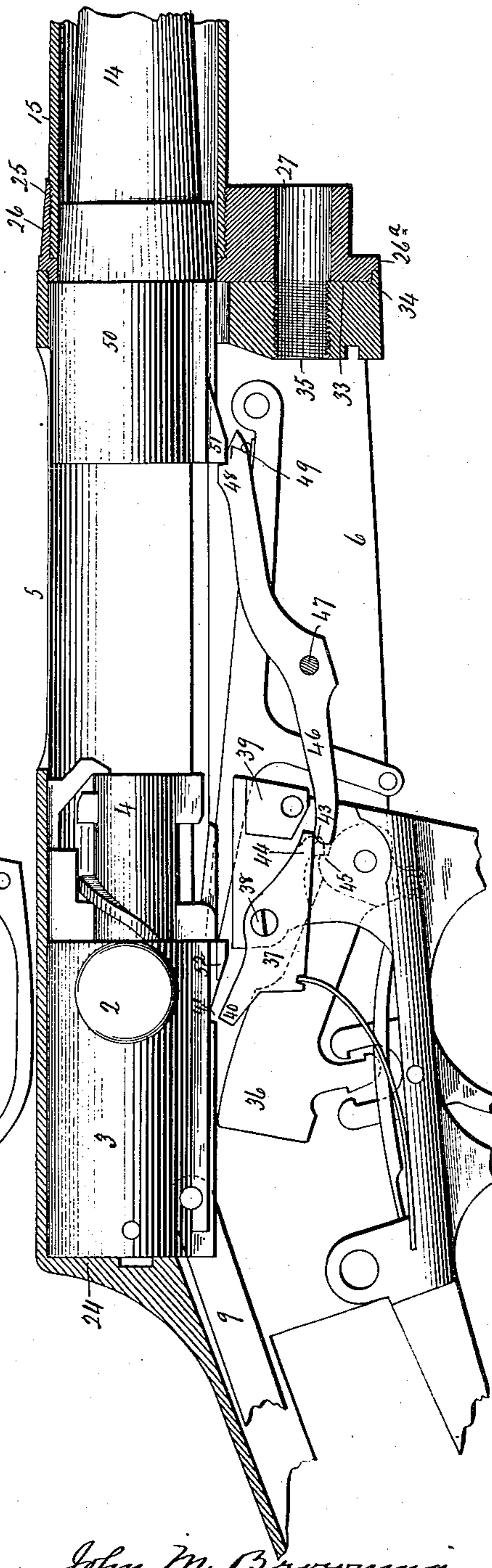

Fig. 9.

Witnesses.
J. H. Shumway.
Lillian D. Kelbey.

John M. Browning,
Inventor.
By atty. Seymour & Carey.

No. 701,288.

Patented June 3, 1902.

J. M. BROWNING.
RECOIL OPERATED FIREARM.

(Application filed Mar. 18, 1901.)

(No Model.)

4 Sheets—Sheet 4.

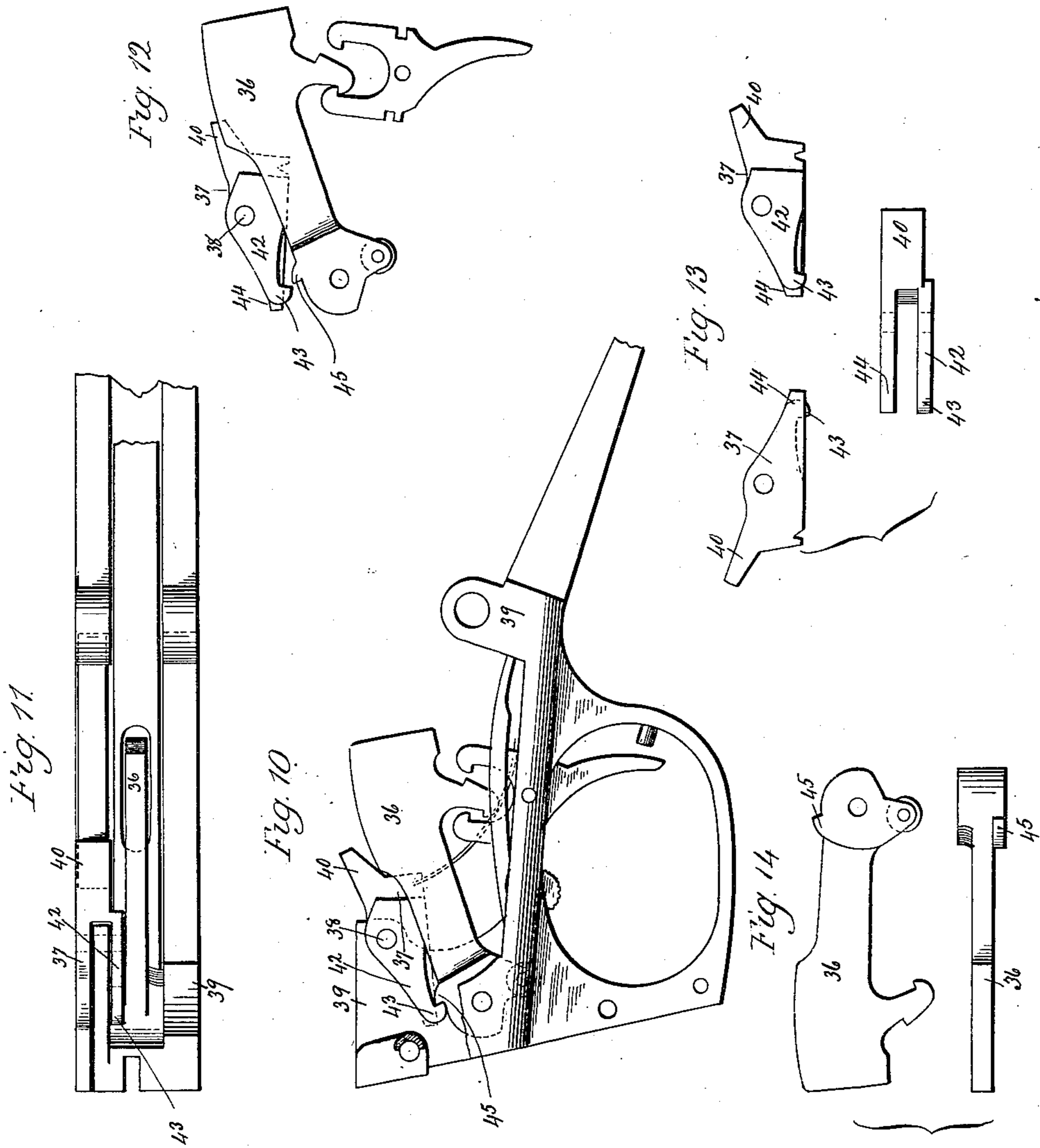

Witnesses
J. H. Shumway
Lillian D. Kellogg

John M. Browning,
Inventor.
By attys Seymour & Coe

UNITED STATES PATENT OFFICE.

JOHN M. BROWNING, OF OGDEN, UTAH.

RECOIL-OPERATED FIREARM.

SPECIFICATION forming part of Letters Patent No. 701,288, dated June 3, 1902.

Application filed March 18, 1901. Serial No. 51,698. (No model.)

To all whom it may concern:

Be it known that I, JOHN M. BROWNING, of Ogden, in the county of Weber and State of Utah, have invented a new Improvement in Recoil-Operated Firearms; and I do hereby declare the following, when taken in connection with the accompanying drawings and the letters of reference marked thereon, to be a full, clear, and exact description of the same, and which said drawings constitute part of this specification, and represent, in—

Figure 1, a broken view, in right-hand side elevation, of a gun constructed in accordance with my invention; Fig. 2, a similar but less comprehensive plan view; Fig. 2^a, a view in front elevation of the frame or receiver stripped of its applied parts; Fig. 2^b, a view in rear elevation of the take-down head located upon the rear end of the barrel-jacket; Fig. 3, a broken left-hand side view of the gun; Fig. 4, a detached broken view in right-hand side elevation, showing the barrel extension, the fore-arm, and the rear end of the jacket inclosing the barrel; Fig. 5, a broken view, partly in vertical longitudinal section and partly in elevation, showing the breech mechanism of the gun in the closed and fired positions thereof and also showing the take-down feature of the gun; Fig. 6, a broken view, in vertical section, through the barrel-jacket, showing the barrel in elevation; Fig. 7, a view in vertical transverse section through the barrel-jacket on the line *a b* of Fig. 6; Fig. 8, a broken view of the gun, partly in side elevation and partly in vertical section, showing the parts of the breech mechanism as locked together during the recoil of the barrel and showing the barrel at the limit of its recoiling movement and still coupled with the breech-bolt of the breech mechanism; Fig. 9, a corresponding view showing the gun as open, the barrel having now been unlocked from the breech-bolt and returned to its normal position; Fig. 10, a detached view, in left-hand side elevation, of the tang of the gun, showing the hammer and the safety-dog thereof; Fig. 11, a plan view of the same parts; Fig. 12, a detail view in elevation, showing the hammer, the trigger, and the safety-dog in the firing position of the hammer; Fig. 13, a view comprising views in side elevation and plan of the safety-dog; Fig. 14, a view

comprising a side elevation and a plan view of the hammer.

My invention relates to an improvement in recoil-operated firearms, its object being to construct a comparatively simple, durable, effective, and safe arm, following the general plan and in some particulars the construction of the arm shown and described in United States Patent No. 659,786, granted to me under date of October 16, 1900.

With these ends in view my invention consists in certain details of construction and combinations of parts, as will be hereinafter described, and pointed out in the claims.

As my present invention is virtually an improvement upon the arm of my prior patent above referred to, I shall confine myself for the most part to describing the features of my present improvement without going into a further description of the construction and operation of the arm than is incidentally necessary in connection with features of present novelty.

In carrying out my invention I secure a handle or hand-grip 2 directly and rigidly to the right-hand side of the forward end of the chambered bolt-carrier 3, which receives the rotatable breech-bolt 4, the said bolt-carrier and breech-bolt constituting the breech-closure of the gun and corresponding to the same parts in my said prior patent. The said handle projects laterally through the loading and ejecting opening 5, formed in the gun frame or receiver 6, and in the rearward portion of its excursion forward and back moves in a narrow longitudinal slot 7, leading out of the rear end of the said opening 5, the stem 8 of the handle being made flat and arranged horizontally for being received by the said slot. In manually opening the gun preparatory to loading it the breech-bolt and bolt-carrier are drawn back into their open positions by means of this handle rather than through the medium of the operating-link 9, as in the construction of my prior patent. For this reason it is not necessary that the rear end of the link should be pivotally connected with the plunger 10, which is surrounded by the bolt-spring 11, as in my said patented construction; but the rear end of the link terminates in a nose 12, which has a ball-and-socket movement in a socket 13, formed in the head of the plunger.

In my present construction the barrel 14 of the gun is inclosed very nearly throughout its entire length by means of a tubular barrel-jacket 15, made of steel or equivalent material and forming a support for the barrel in its recoiling and returning movements. An external screw-thread formed upon the extreme forward end of the barrel receives an internally-threaded collar 15^a, formed at its rear end with an annular shoulder 16, which in the normal position of the barrel fits within the outer end of a bushing 17, having external threads which take into internal threads formed within the extreme forward end of the jacket, the extreme forward edge of which abuts against a shoulder 18, formed at the outer end of the bushing 17. A spiral barrel-spring 19, encircling the barrel 14, abuts at its forward end against the shoulder 16 of the collar 15^a and at its rear end against the inwardly-turned flange 20 of a tubular stop 21, which extends forward over a portion of the said barrel-spring. The said tubular stop 21 itself rests against the forward coil of a heavier and larger, but much shorter, buffer-spring 22, also encircling the barrel 14 and resting at its rear end against an abutment-collar 23, fixed within the barrel-jacket.

When the gun is fired, the barrel recoils against the tension of the barrel-spring 19 until the rear portion of the collar 15^a on the barrel strikes the forward end of the tubular stop, at which time the barrel-spring has been entirely forced within the same and at which time the force of recoil is transferred from the barrel-spring to the stop, which transmits it to the heavier buffer-spring 22, which is thus compressed in addition to the compression of the barrel-spring, whereby both springs act in reducing the shock of recoil. I particularly wish to point out that the buffer-spring 22, being stiffer than the barrel-spring 19, markedly increases the resistance to recoil just before the rear end of the bolt-carrier 3 impinges against the wall 24 of the gun frame or receiver. On the other hand, when the barrel begins its return or forward movement the barrel-spring 19 is for a brief period reinforced and assisted by the heavier buffer-spring 22, which recovers in time to assist the barrel-spring in starting the spent shell, which is subsequently extracted and which very often requires considerable power to start it.

In order to provide for taking the gun down for convenience in packing and transporting it, I locate what I shall term a "take-down head" at the rear end of the barrel-jacket 15. This take-down head is preferably made in one piece and comprises a body 25, the upper portion of which is formed with an internally-threaded opening 26 for the reception of the externally-threaded rear end of the barrel-jacket 15 and the lower portion of which is formed with a threadless bolt-hole 27 for the reception of a removable screw-bolt 28, the head of which is received in a chamber 29, formed in the rear end of the fore-stock

30, which is secured in place by a screw 31, passing up through the stock into an internally-threaded post 32, depending from the barrel-jacket. The plate 26^a, forming a part of the take-down head, is made oval in general form, Fig. 2^b, so as to conform it to the cross-sectional form of the forward end, Fig. 2^a, of the gun frame or receiver 6. The rear face of this plate, which might also be termed a "flange," is formed with a shoulder 33, conforming to the plate in outline and adapted to enter a shallow recess 34, formed in the forward end of the receiver 6, so as to fit therein closely. The threaded rear end of the screw-bolt 28 takes into a threaded opening 35, formed in the forward end of the receiver. When the said bolt is turned by means of the bolt-head at its forward end, the shoulder 33 of the take-down head is drawn into the recess 34 and the edge of the plate or flange 26^a seated firmly against the extreme forward edge of the receiver, whereby the take-down head is firmly secured in place, so as to give a solid support for the barrel-jacket, which incloses and supports the barrel. To take down the gun, it is only necessary to remove the fore-stock 30 and then the screw-bolt 28, which permits the barrel-jacket and the barrel to be separated from the rest of the gun.

In order to prevent the hammer 36 from falling before the gun has been closed and locked, even though the hammer may have been released by the trigger, I employ a safety-dog 37, which in my present gun performs the twofold function of locking the bolt-carrier 3 in its open position and of holding the hammer against falling until the gun has been closed and locked. In its general construction and arrangement this dog 37 corresponds to the part P shown and described in my said prior patent; but as I now construct it it has the additional function of coacting as a safety-dog with the hammer. The dog 37 rocks upon a screw-pivot 38, mounted in the tang 39, and is formed at its rear end with a nose 40, which enters a locking-notch 41, formed in the bolt-carrier. At its forward end the dog is formed with an arm 42, terminating in a hook 43, and also with a beveled operating-arm 44. The said hook 43 coacts with a small lug 45, formed near the base of the hammer 36, while the arm 44 of the dog coacts with the rear end of a lever 46, hung upon a pivot 47, mounted in the receiver and formed at its forward end with a cam-like surface 48 and with a notch 49, located just in front of the said surface.

When the gun is fired, the barrel 14, the barrel extension 50, the breech-bolt 4, and the bolt-carrier 3 recoil together into the positions shown by Fig. 8 of the drawings, in which the nose 40 of the dog 37 snaps into the locking-notch 41 in the bolt-carrier 3, which is thus locked in its open position. At the same time the forward end of the dog is depressed so as to bring the hook 43 of its

arm 42 into engagement with the lug 45 of the hammer 36, which is thrown back into its cocked position by the riding of the bolt-carrier 3 over it. The buffer-spring 22 and the barrel-spring 19 now act immediately to cause the rotation of the breech-bolt 4, whereby the same is unlocked from the barrel extension 50, leaving the same and the barrel 14 free to be returned to their normal position by the action of the said springs. Just before they reach the limit of their forward movement the lug 51, depending from the barrel extension, passes over the cam-like surface 48 of the lever 46, whereby the forward end of the lever is depressed, with the effect of lifting its rear end and turning the dog 37 so as to disengage its nose 40 from the locking-notch 41 of the bolt-carrier 3. At the same time the hook 43 of the dog 38 is lifted above and out of engagement with the lug 45 of the hammer, which, however, is at this time held in its fully-depressed position by the bolt-carrier 3, as shown in Fig. 9; but when the lug 51 passes over the cam-like surface 48 into registration with the notch 49 in the lever 46 the same lifts at its forward end, and thus permits the rear end of the lever 46 to drop, as shown in Fig. 9, sufficiently to permit the forward end of the dog 37 to move downward sufficiently to reengage its hook 43 with the lug 45 of the hammer 36. It is evident that the hammer cannot now fall until the hook 43 of the dog 37 has been disengaged from its lug 45, and, furthermore, that that disengagement cannot be effected except through the depression of the forward end of the lever 46, which does not occur until the lug 52, formed at the forward end of the bolt-carrier, passes over the cam-like surface 48 of the lever and depresses the same; but by that time the gun has been closed and its bolt 4 rotated, so as to be interlocked in the barrel extension 50, permitting the gun to be fired with safety.

To provide for the convenient application and adjustment of the forward sight 53 to the jacket 15, I locate within the jacket a broken ring 54, which springs so as to fill the inside diameter of the jacket. This spring receives the inner ends of the two screws 55, which are passed through the ends of the sight and through transversely-elongated clearance-openings 56, formed in the jacket. When these screws are turned home, the ring 54 is clamped against the inner periphery of the jacket, so as to firmly hold the said sight in any position in which it may be placed. By loosening the screws, however, the sight may be adjusted sidewise within the limits of the clearance-openings 56 in the jacket. When the sight is removed altogether, the ring will not be displaced, on account of its tendency to spring outward. If desired, the rear sight 57 may be secured in place in the same way. I do not, however, claim my improved sight herein, but have made it the subject-matter

of an independent application to be filed before the issuance of this patent.

It is apparent that in carrying out my invention some changes from the construction herein set forth may be made, and I would therefore have it understood that I do not limit myself to the exact details herein shown, but hold myself at liberty to make such changes as fairly fall within the spirit and scope of my invention. Thus the tubular stop 21 may be reversed in position, so as to fit over the forward end of the barrel-spring.

Having fully described my invention, what I claim as new, and desire to secure by Letters Patent, is—

1. In a recoil-operated firearm, the combination with the receiver thereof, of a recoiling barrel, a barrel-jacket secured to the receiver, a barrel-spring encircling the barrel, a buffer-spring encircling the barrel at a point to the rear of the rear end of the said barrel-spring, and a stop coacting with the barrel and bringing the buffer-spring into play after the barrel-spring has been compressed.

2. In a recoil-operated firearm, the combination with the receiver thereof, of a recoiling barrel, a barrel-jacket secured to the receiver, a barrel-spring encircling the barrel, a buffer-spring encircling the barrel at a point to the rear of the rear end of the said barrel-spring, and a stop located outside of the barrel-spring, coacting with the barrel and bringing the buffer-spring into play after the barrel-spring has been compressed.

3. In a recoil-operated firearm, the combination with the receiver thereof, of a recoiling barrel, a barrel-jacket secured to the receiver, a barrel-spring encircling the barrel, a buffer-spring encircling the barrel at a point to the rear of the rear end of the said barrel-spring, and a tubular stop encircling a portion of the barrel-spring and coacting with the barrel to bring the buffer-spring into play after the barrel-spring has been compressed.

4. In a recoil-operated firearm, the combination with a receiver, of a recoiling barrel, a barrel-jacket secured to the receiver, a barrel-spring encircling the barrel, a buffer-spring also encircling the barrel, and a tubular stop coacting at one end with the buffer-spring and adapted to have its other end engaged by a projection from the barrel after the same has begun its recoiling movement.

5. In a take-down recoil-operated firearm, the combination with a receiver having its forward end formed with a bolt-hole, of a recoiling barrel, a barrel-jacket, a take-down head located at the rear end of the said jacket, adapted to fit the forward end of the receiver, and provided with a bolt-hole registering with the said bolt-hole therein, and a screw-bolt passing through the bolt-hole in the take-down head into the bolt-hole in the receiver, whereby the said head is fastened directly to the receiver.

6. In a take-down, recoil-operated firearm,

the combination with a receiver formed at its forward end with a shallow recess, of a recoiling barrel, a barrel-jacket provided at its rear end with a take-down head consisting of a body receiving the rear end of the jacket, and formed with a bolt-hole, and of a plate or flange formed with a shoulder adapted to enter the said recess, a screw-bolt passing through the said bolt-hole in the said head and into the receiver and securing the head directly thereto.

7. In a recoil-operated firearm, the combination with a recoiling barrel, of a breech-closure, a hammer, and a dog coacting with the breech-closure to lock the same in its open position, and coacting with the hammer to prevent the same from falling until after the gun has been closed and locked.

8. In a recoil-operated firearm, the combination with the recoiling barrel and barrel extension thereof, of a breech-closure, a hammer, a dog coacting with the breech-closure to lock the same in its open position, and coacting with the hammer to prevent the same from falling until after the gun is closed and

locked, and a lever coacting with the said dog and operated upon at its forward end by the barrel extension and by the breech-closure in the order named.

9. In a recoil-operated firearm, the combination with the recoiling barrel and barrel extension thereof, of a breech-closure, a hammer, a dog coacting at its rear end with the breech-closure to lock it in its open position, and formed at its forward end with two arms, one of which is provided with a hook for engaging with the hammer, and a lever coacting at its rear end with the other arm of the dog, and acted upon at its forward end by the barrel extension and the breech-closure in the order named, just before they reach their closed positions.

In testimony whereof I have signed this specification in the presence of two subscribing witnesses.

JOHN M. BROWNING.

Witnesses:

A. L. ULRICH,
S. MONKS.