

(No Model.)

2 Sheets—Sheet 1.

FERDINAND RITTER VON MANNLICHER. AUTOMATIC FIREARM.

No. 581,295.

Patented Apr. 27, 1897.

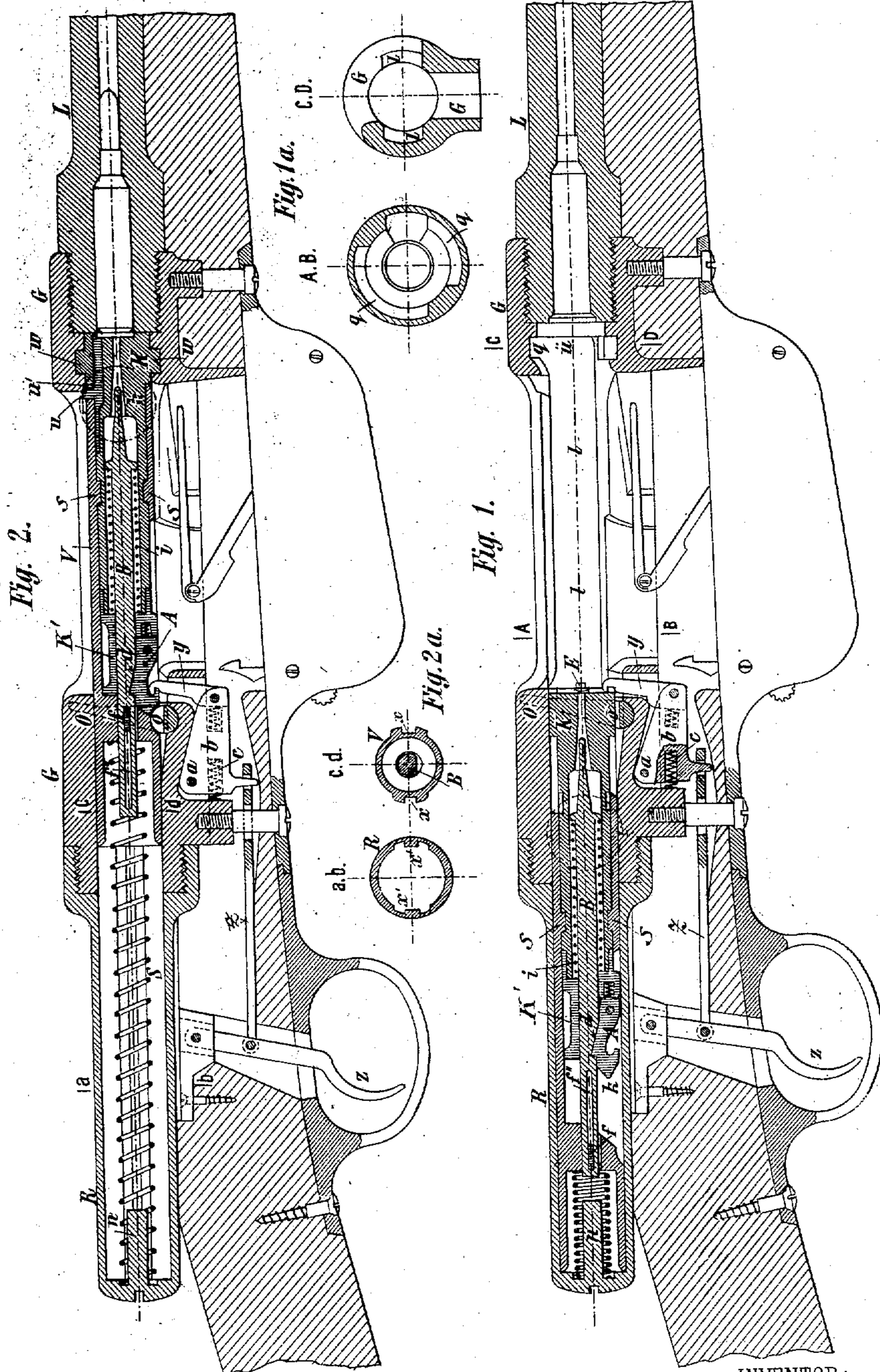

WITNESSES:
A. Benesch.
G. Kretschmar.

INVENTOR:
 Ferd. Ritter v. Mannlicher
 by *Robert B. Jentzsch.*
 ATTORNEY.

(No Model.)

2 Sheets—Sheet 2.

FERDINAND RITTER VON MANNLICHER. AUTOMATIC FIREARM.

No. 581,295.

Patented Apr. 27, 1897.

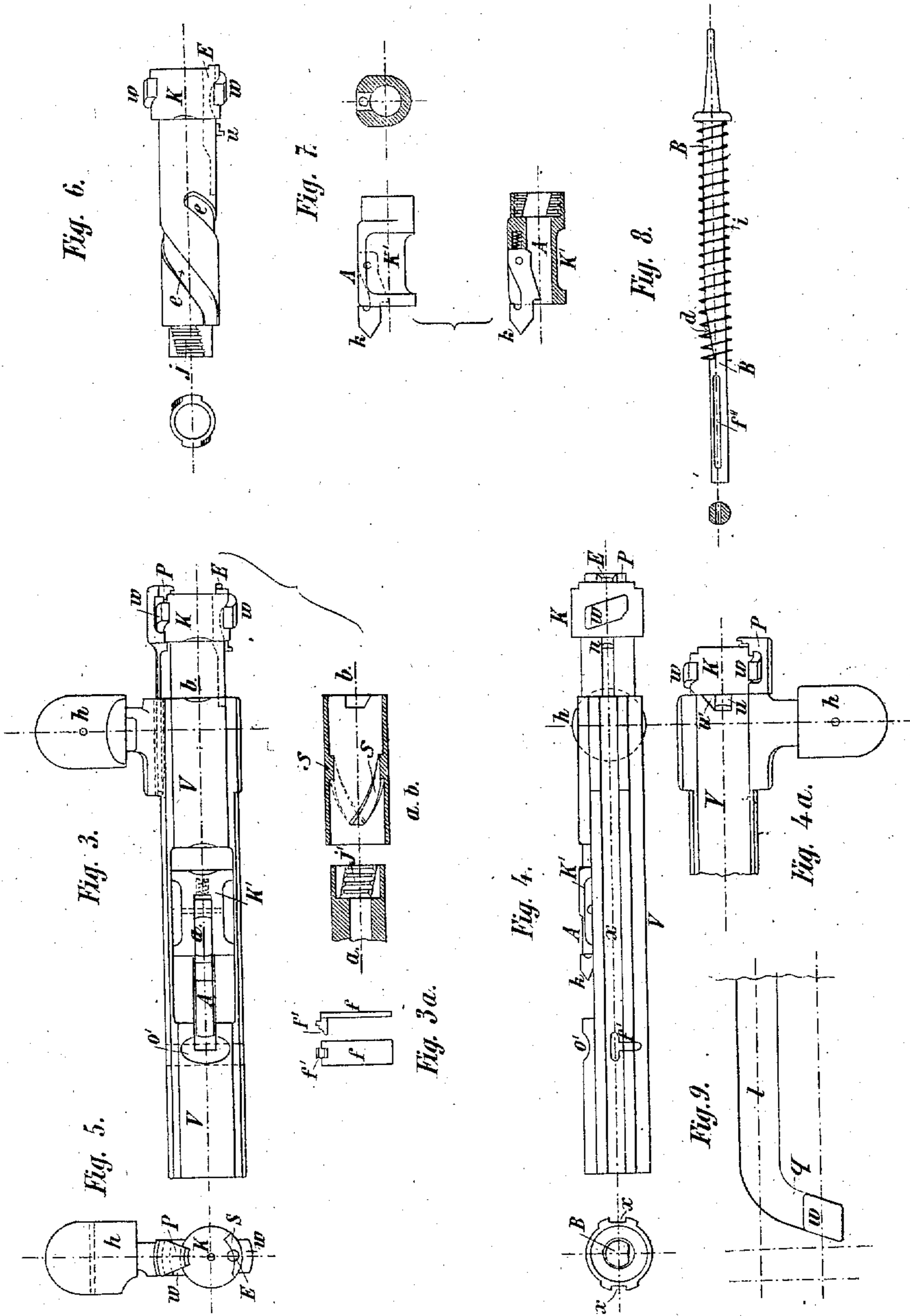

WITNESSES:
A. Benesch
G. Kuchniawy

INVENTOR:
 Ferd. Ritter v Mannlicher
 by *Robert B. Jentzsch*
 ATTORNEY.

UNITED STATES PATENT OFFICE.

FERDINAND RITTER VON MANNLICHER, OF VIENNA, AUSTRIA-HUNGARY.

AUTOMATIC FIREARM.

SPECIFICATION forming part of Letters Patent No. 581,295, dated April 27, 1897.

Application filed March 4, 1895. Serial No. 540,554. (No model.) Patented in Germany December 18, 1893, No. 78,615; in France February 1, 1894, No. 232,913; in Belgium February 3, 1894, No. 108,388; in Austria February 23, 1894, No. 44/176; in England February 7, 1894, No. 2,687; in Italy March 31, 1894, XXVIII, 35,803, LXX, 193; in Switzerland August 9, 1894, No. 9,118, and in Hungary November 18, 1895, No. 4,523.

To all whom it may concern:

Be it known that I, FERDINAND RITTER VON MANNLICHER, a subject of the Emperor of Austria-Hungary, and a resident of the city of Vienna, Austria-Hungary, have invented new and useful Improvements in Automatic Firearms, (patents for which have been granted to me in Austria February 23, 1894, No. 44/176; in Hungary November 18, 1895, No. 4,523; in Germany December 18, 1893, No. 78,615; in Great Britain February 7, 1894, No. 2,687; in France February 1, 1894, No. 232,913; in Belgium February 3, 1894, No. 108,388; in Italy March 31, 1894, Vol. XXVIII, No. 35,803, Vol. LXX, No. 193, and in Switzerland August 9, 1894, No. 9,118,) of which the following is a specification.

My invention relates to automatic repeating-rifles with a rigid or stationary barrel, and has for its object the construction of a rifle of this kind with an automatic straight or single-motion breech-bolt, which is opened by the rearward pressure of the cartridge-shell when a shot is fired and which is closed again by a spring.

In the annexed drawings a rifle constructed according to my invention is shown, in which—

Figure 1 represents a longitudinal vertical section of the rifle with open breech-bolt. Fig. 1^a shows two cross-sections after lines A B and C D of Fig. 1. Fig. 2 is a similar section to that in Fig. 1, but with the breech-bolt closed and the firing-pin in cocked position. Fig. 2^a shows two cross-sections after lines a b and c d of Fig. 2. Fig. 3 is a bottom view of the breech-bolt with two partial sections after line a b of this figure. Fig. 3^a shows in two views the key inserted in the breech-bolt. Fig. 4 shows a right side and an end view of the breech-bolt. Fig. 4^a is a top view of the forward part of the breech-bolt. Fig. 5 is a forward end view of the breech-bolt. Fig. 6 shows the breech-bolt head in two views. Fig. 7 shows in side view and two sections the coupling-piece of the breech-bolt with the sear. Fig. 8 shows the firing-pin and spring. Fig. 9 is a diagram showing a longitudinal or guide groove and a transverse

or locking groove in the receiver with a locking-stud in its locked position.

In all the figures similar letters of reference indicate like parts.

The rifle essentially consists of the barrel L, the breech-receiver G, the breech-bolt V, the closing-spring S, the tube R, the firing-pin B with the spring i, the trigger mechanism, and of the magazine. The breech-receiver G, to which the barrel L is attached, is provided with the lateral guide-grooves for the breech-bolt and with the transverse grooves or recesses q, into which the corresponding studs of the breech-bolt may lock. The breech-bolt consists of the bolt proper, V, with the handpiece h of the bolt-head K, and of the coupling-piece K'. The cylindrical bolt-head K carries at or near its forward end the locking-studs w and is, with its reduced rear end, inserted into the forward part of the bolt proper, V, in such manner that the screw-threads s and e, with which the bolt V and the head K are respectively provided, will engage into each other.

The bolt V is provided with lateral ribs, by means of which it is guided in the grooves l of the receiver and in grooves x' of the extension-tube R. In this manner the bolt V is prevented from turning and can only perform a rectilinear movement in the receiver.

The bolt-head K, which is hollow, contains the firing-pin B, with its spring i, and is closed at its rear end by the coupling-piece K', both parts K and K' being connected by a clutch connection j j', as shown. When the bolt-head K and the bolt V are in position in the receiver, where they cannot turn beyond ninety degrees with reference to each other, the said connection prevents them from separating. Only when the bolt is turned beyond ninety degrees with reference to the bolt V the clutch becomes disconnected, and the head may be separated from the bolt or the coupling-piece, respectively. As on account of the screw-threads s in the interior of the bolt V the coupling-piece K' cannot be introduced into the bolt through its forward end like the bolt-head, the bolt V must be provided with a suitable opening at

its under side for permitting the introduction of the coupling-piece. After the coupling-piece K' has thus been placed into the bolt V the head K is introduced through the forward end of the latter and is connected with the coupling-piece by means of the clutch, whereby a proper casing is formed for the firing-spring i . The firing-pin is provided with a slot f'' , through which passes a key f , which is driven horizontally through the bolt V and which is provided with a head f' for keeping it in position. The firing-pin is furthermore provided with a rest d , into which may engage the spring-actuated sear A , which is pivoted in the coupling-piece K' . As seen from the diagram, Fig. 9, the locking grooves or recesses g are not at right angles to the longitudinal or guide grooves l in the receiver, but rise in a certain measure in a forward direction in the manner of a screw-thread. The locking-studs w are correspondingly placed upon the bolt-head, also resembling part of a screw-thread. The pitch of this thread must here be somewhat steeper than the angle of resistance, so that at the moment of firing the locking-studs will find sufficient resistance in their locking-grooves during the explosion, at the same time, however, permitting the bolt-head to turn open through the force of the recoil. Supposing the bolt-head at the moment of firing to perform this rotary opening motion, the bolt V will at first, in consequence of its screw connection with the head K , be driven back a distance corresponding to the pitch of these connecting screw-heads s and e —for instance, seventeen twenty-fourths of an inch to ninety degrees. Then, the locking-studs w having entered the longitudinal guide-grooves l , both parts, the head K and the bolt V , continue this rearward rectilinear movement until the bolt V strikes against the end of the extension-tube R and is stopped. As soon as the head K begins to turn open and the bolt recedes the key f , which is attached to the latter, operates against the rear end of the slot f'' in the firing-pin, whereby this latter is carried back and the firing-spring is tightened. At the end of this movement the sear A springs into the notch d of the firing-pin and retains it in its cocked position until it is released by the trigger. The bolt having completed its rearward movement by which it has compressed the spring S , this latter drives it forward again. The locking-studs w being guided in grooves l the head K is prevented from turning, and both it and the bolt V move forward in a straight line until the locking-studs w have arrived at the end of the grooves l , opposite their locking-recesses g . Here the straight forward movement of the head K must cease, but the bolt V , continuing this movement, causes, by the aforesaid screw connection of the two parts, the head K to turn, whereby the studs w are made to enter their recesses g , and the bolt

is again locked. The breech-bolt V having in its forward movement taken a fresh cartridge from the magazine and introduced the same into the chamber in the barrel, the rifle is ready for the next shot as soon as the trigger is released and pulled again. The trigger Z is by an arm z connected with a bell-crank lever b , pivoted underneath the receiver and pressed forward by a spring c . To the forward end of this lever b is jointed a spring-pressed arm y , which points upward and is adapted to engage with its hooked end into a corresponding hook of the sear A , pivoted in the coupling-piece K of the bolt. When the trigger Z is pulled back, the hook of the arm y cannot engage into the corresponding hook of the sear A . On account of the movements of the breech-bolt after a shot taking place so rapidly the breech-bolt has arrived in its closed position before the finger has had time to release the pull upon the trigger which fired the previous shot. Thus it becomes necessary to first release the trigger, whereby the lever b is allowed to swing forward and the arm y to move upward, so that its hooked end may engage into the hooked part of the sear A , as shown in Fig. 2. Now a fresh pull upon the trigger will operate the sear A and fire the next shot. The arm y also serves to retain the breech-bolt in open position when the same has been opened by hand. As in this case there is no pull upon the trigger, the upper part of the arm y rises in front of the breech-bolt and prevents its forward movement. A forward blow with the hand against the handpiece h of the breech-bolt will, however, suffice to overcome the resistance of the arm y and to allow the breech-bolt to close. When the breech-bolt is opened by hand, the movement of the parts is reversed, as in this case the opening impulse is not imparted to the bolt-head, but by hand to the breech-bolt V . Thus when the handpiece h is pulled back the rearward movement of the breech-bolt V , in consequence of their screw connection, imparts the rotary unlocking movement to the head K , whereupon both parts may be pulled back in a straight line.

The extractor, which is of the known kind, is at its rear part formed into a spring and is inserted into a slit in the rib upon the right side of the bolt V , wherein it may slide, while its head is bent over the right locking-stud, so that the same may freely perform its rotary movement in locking and unlocking. The ejector is a pin inserted into a hole in the bolt-head K . The ejector E has a slight back-and-forward movement and is at its rear part provided with a nose u , which when the bolt is opened strikes against a projection in the receiver and imparts a sudden forward movement to ejector E , whereby the empty cartridge is ejected. The construction and arrangement of this ejector are also known.

The magazine which I have shown in the annexed drawings by way of example is one

of my own construction for packet-charges, but any other system of magazine may be employed with the mechanism described.

In the annexed drawings I have also shown by way of example a safety for preventing the accidental release of the firing-pin. This safety consists of a shaft *o*, passing transversely through the receiver and provided with a handle or thumb-piece *O* for giving it half a turn. When the handle *O* is turned down, the shaft *o* rests against the rear slanting surface *k* of the sear *A*, and thus prevents this latter from being pulled down out of engagement with the cocked firing-pin. In this position the shaft *O* also rests in a depression or recess *o'* of the bolt *V*, whereby the bolt is also prevented from being opened. When the handle *O* is turned up, a flat or recessed part of the shaft *o* faces the sear *A* and the breech-bolt, so that these parts are not prevented from operating.

What I claim is—

1. In firearms, the combination with a rigid or stationary barrel of an automatic straight or single-motion breech-bolt, essentially consisting of the bolt proper *V* and of the bolt-head *K* provided with locking-lugs *w* placed at a certain pitch, bolt *V* and head *K* engaging with each other by means of a screw-thread, and bolt *V* provided with lateral guide-ribs *x*, of a receiver provided with guide-grooves *l* and locking grooves or recesses *q* of a pitch corresponding to that of the locking-lugs *w*, and of a spring *S*; substantially as and for the purpose described.

2. In firearms, the combination with a rigid or stationary barrel of an automatic straight or single-motion breech-bolt, essentially con-

sisting of the bolt proper *V*, a coupling-piece *K'* and of the bolt-head *K* provided with locking-lugs *w* placed at a certain pitch, bolt *V* and head *K* engaging with each other by means of a screw-thread, and bolt *V* provided with lateral guide-ribs *x*, of a receiver provided with guide-grooves *l* and locking grooves or recesses *q* of a pitch corresponding to that of the locking-lugs *w* and of a spring *S*; substantially as and for the purpose described.

3. In firearms, the combination with a rigid or stationary barrel of an automatic straight or single-motion breech-bolt, essentially consisting of the bolt proper *V*, a coupling-piece *K'* with the sear *A* pivoted thereto and of the bolt-head *K* provided with locking-lugs *w* placed at a certain pitch, bolt *V* and head *K* engaging with each other by means of a screw-thread and bolt *V* provided with lateral guide-ribs *x*, of a receiver provided with guide-grooves *l* and locking grooves or recesses *q* of a pitch corresponding to that of the locking-lugs *w*, and of a spring *S*, substantially as and for the purpose described.

4. In firearms with a rigid or stationary barrel and an automatic straight or single-motion breech-bolt of the kind herein described, a device for cocking the firing-pin consisting of a key *f* inserted into the breech-bolt and engaging into a slit *f''* in the firing-pin; substantially as and for the purpose described.

In testimony whereof I have affixed my signature in presence of two witnesses.

FERDINAND RITTER VON MANNLICHER.

Witnesses:

HARRY BELMONT,
JOSEF ZEHETNER.