

(No Model.)

3 Sheets—Sheet 1.

J. M. BROWNING.  
FIREARM.

No. 580,924.

Patented Apr. 20, 1897.

Fig. 1.

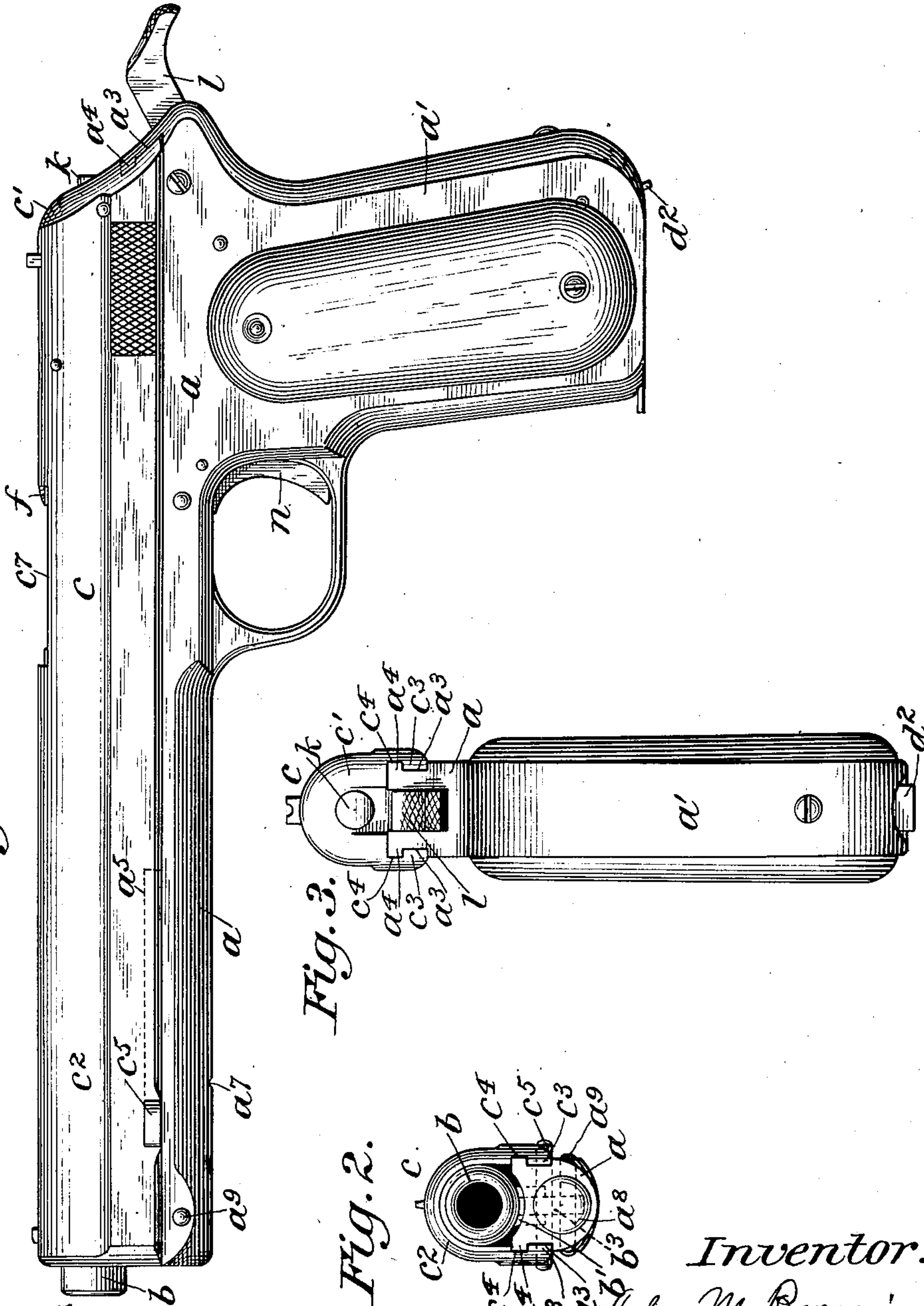

Fig. 2.

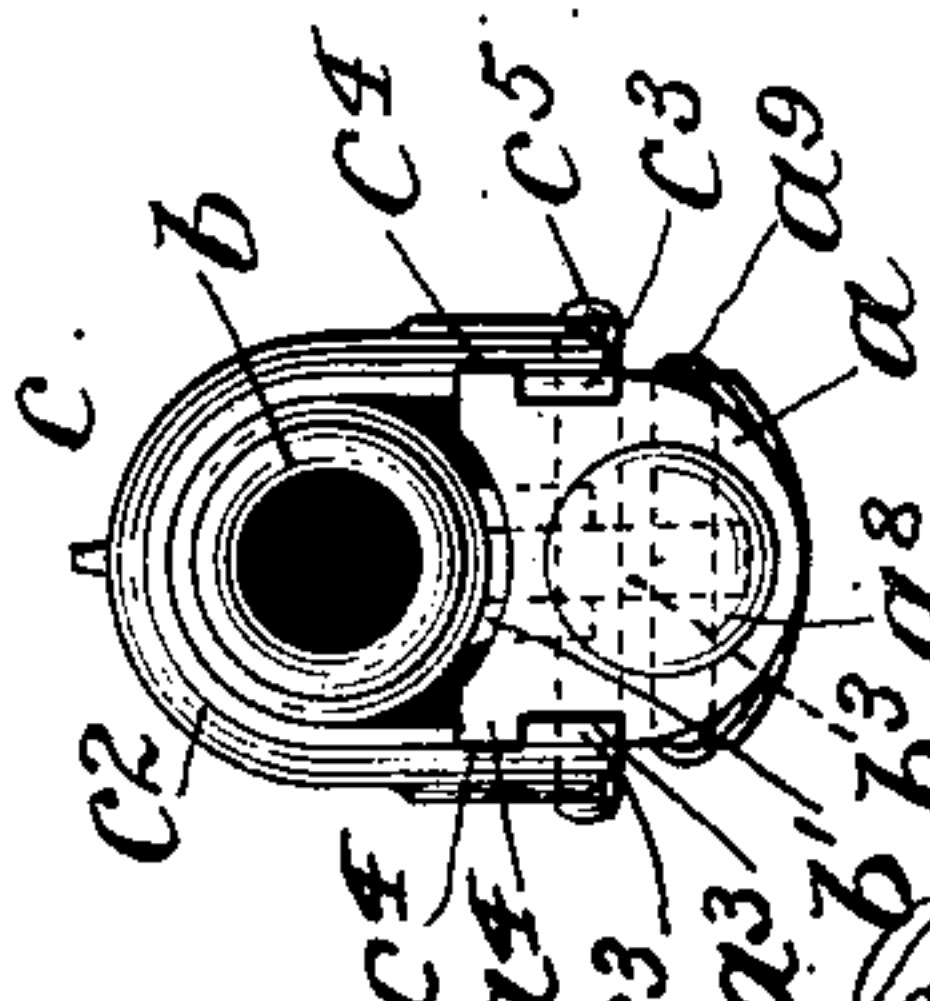
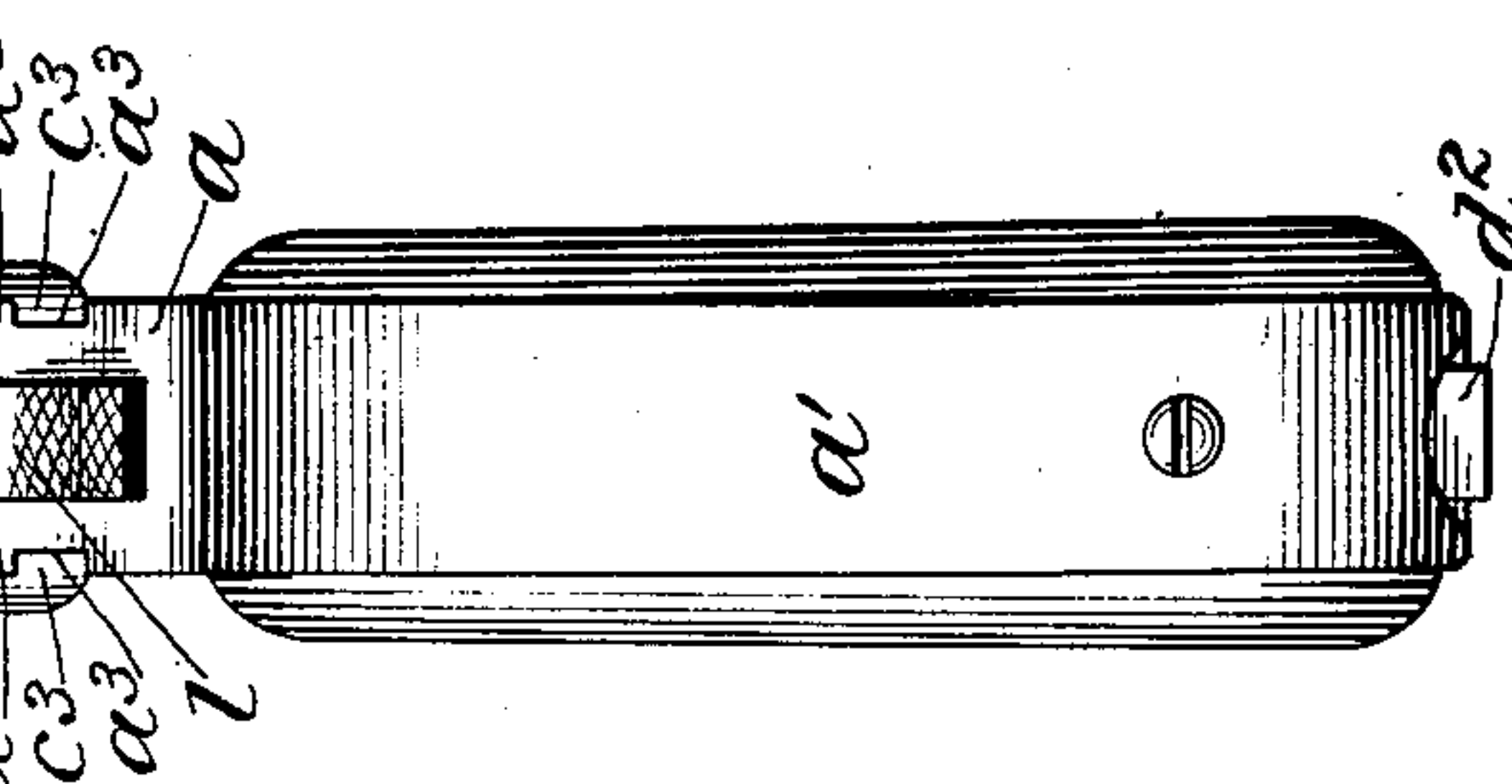

Fig. 3.



Attest:  
A. N. Jesbera  
Chas. E. Epworth

Inventor:  
John M. Browning  
by Redding, Kiddle & Greeley  
Attys.

(No Model.)

3 Sheets—Sheet 2.

J. M. BROWNING.  
FIREARM.

No. 580,924.

Patented Apr. 20, 1897.

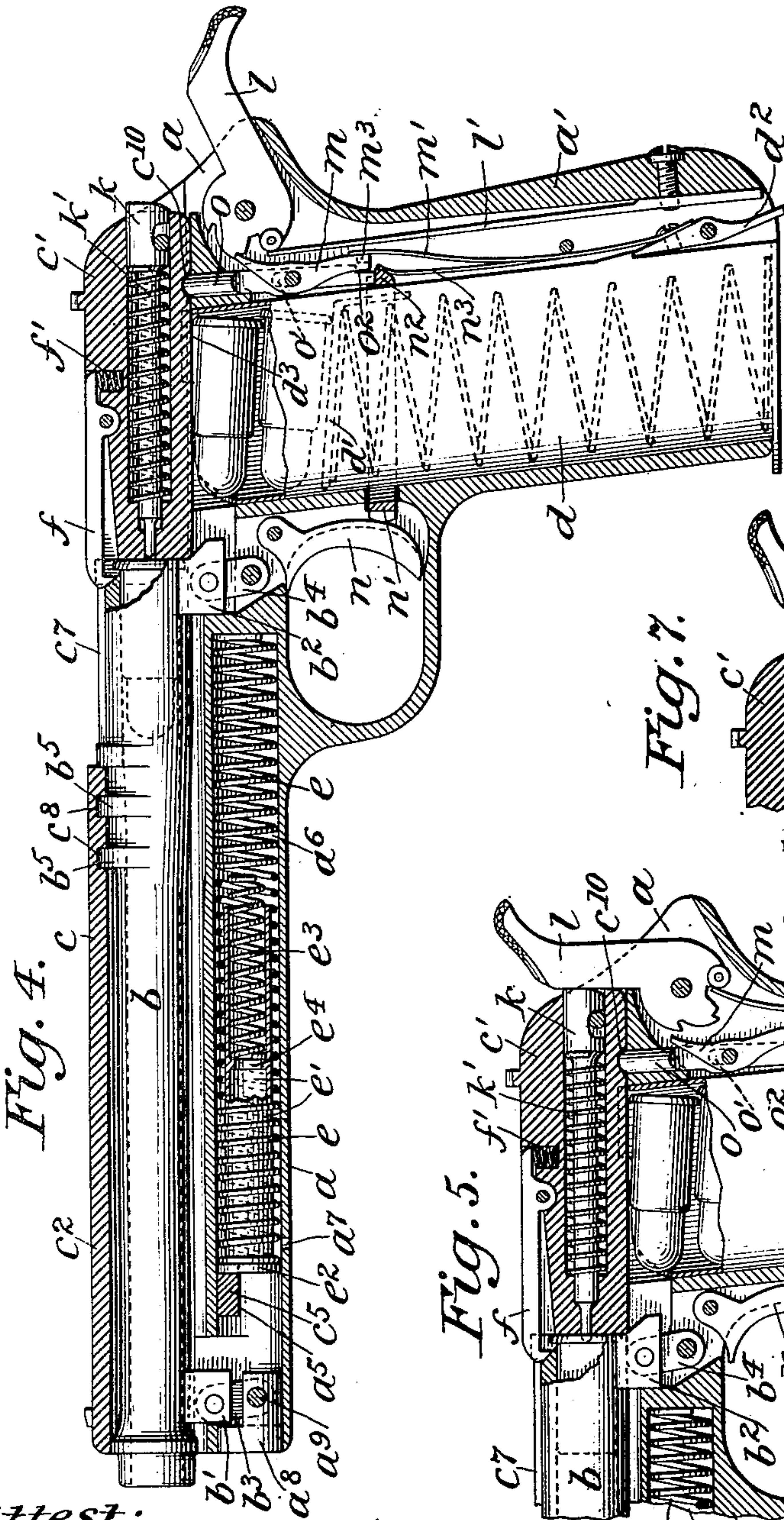

Fig. 4.

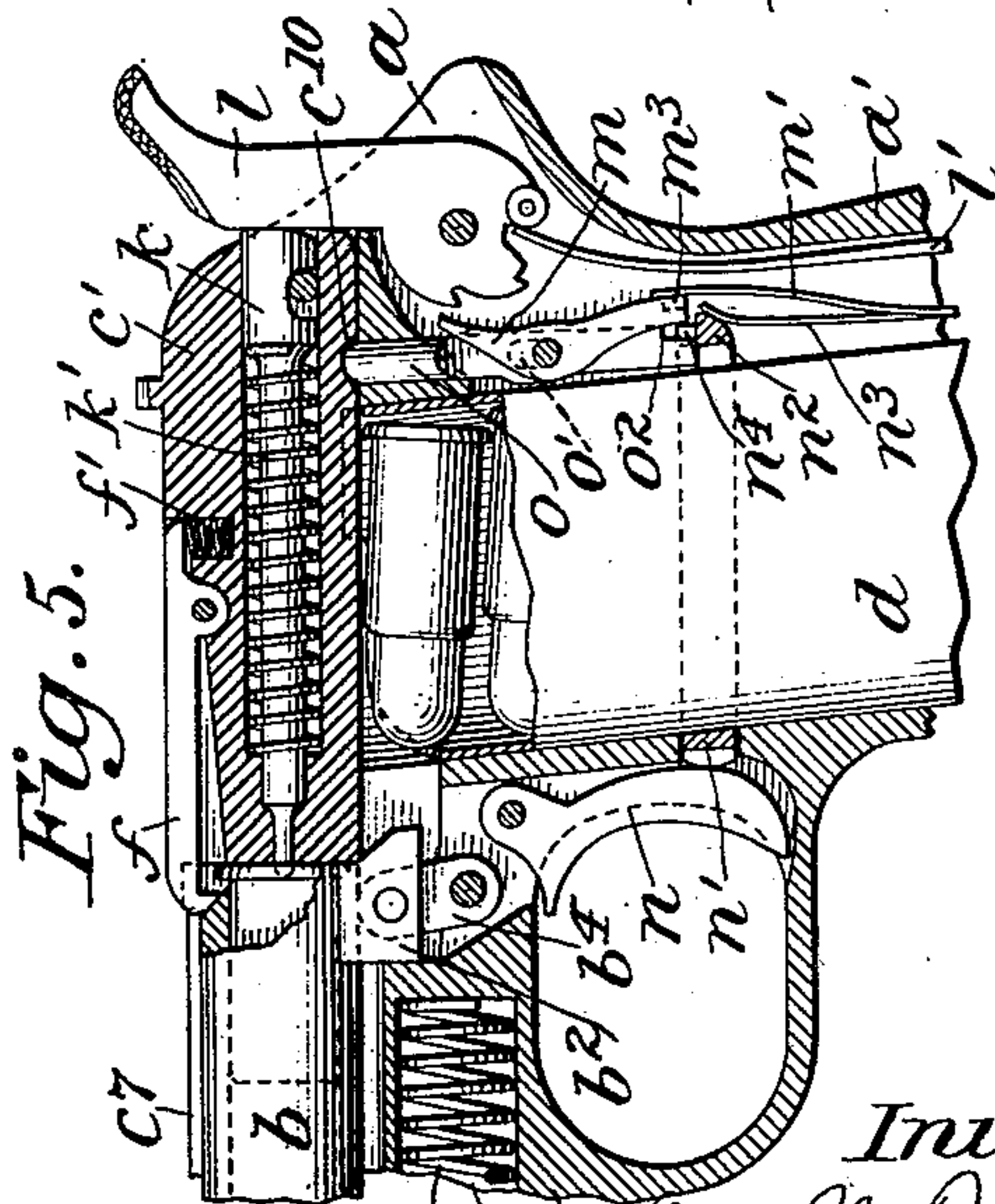

Fig. 5.

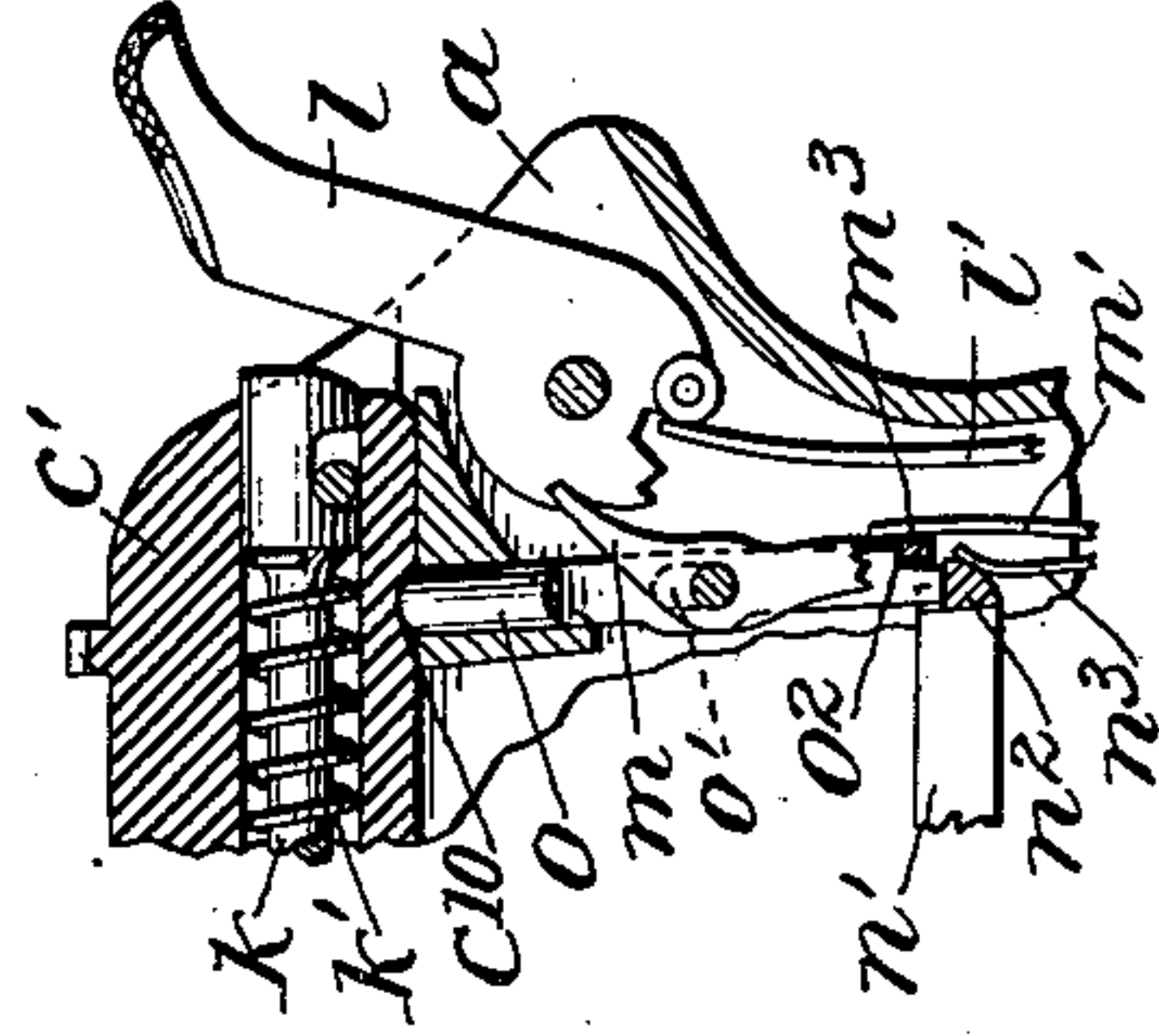

Fig. 7.

Attest:  
A. N. Jester.  
Chas. E. Epworth.

Inventor:  
John M. Browning  
by Redding, Kiddell & Guiley  
Attys.



**J. M. BROWNING.  
FIREARM.**

No. 580,924.

Patented Apr. 20, 1897.

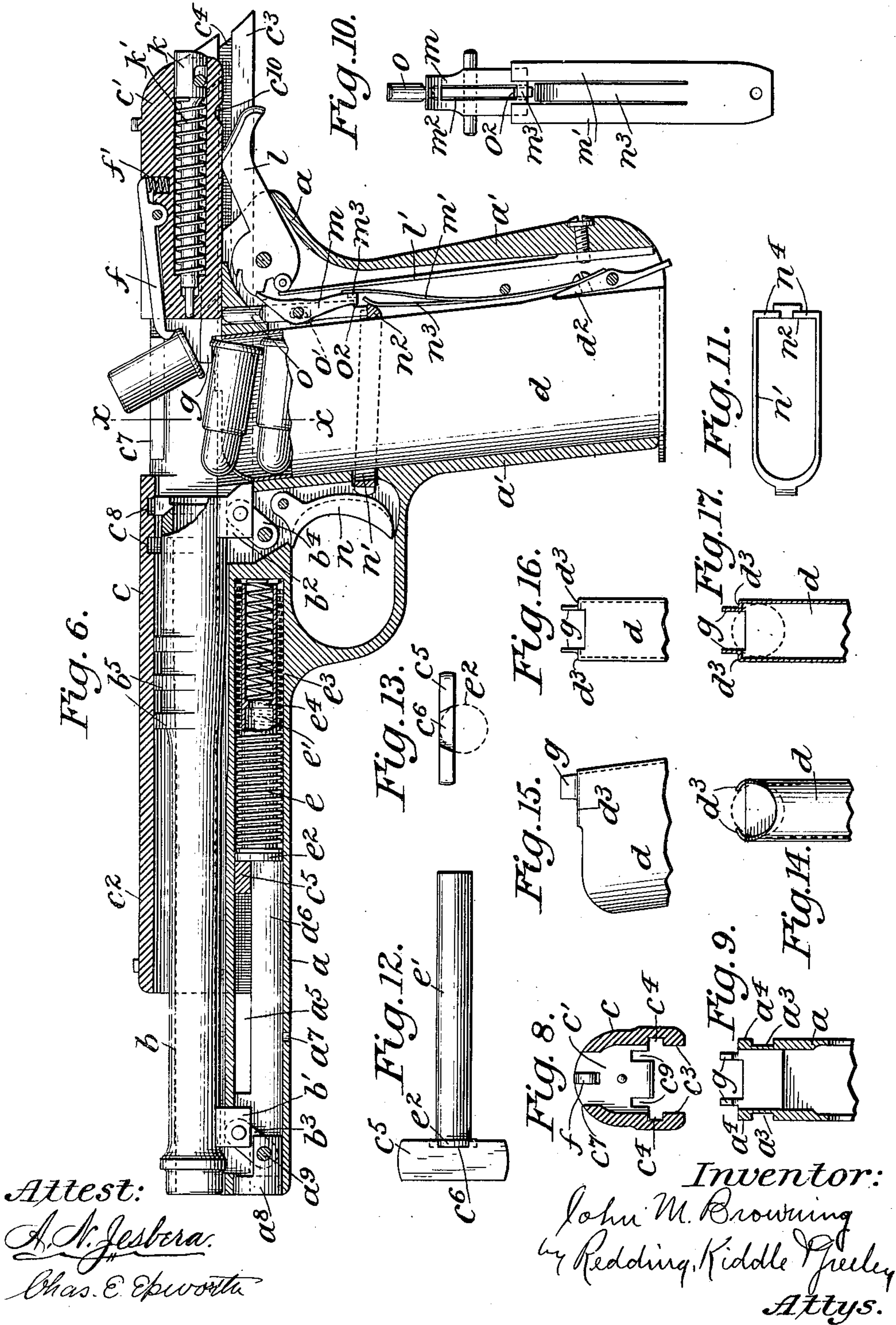

Attest:  
*A. N. Jesbera.*  
*Chas. E. Epworth*

Inventor:  
*John M. Browning*  
by *Redding, Kiddle & Greeley*  
*Attys.*



# UNITED STATES PATENT OFFICE.

JOHN M. BROWNING, OF OGDEN, UTAH.

## FIREARM.

SPECIFICATION forming part of Letters Patent No. 580,924, dated April 20, 1897.

Application filed October 31, 1896. Serial No. 610,657. (No model.)

*To all whom it may concern:*

Be it known that I, JOHN M. BROWNING, of Ogden, in the county of Weber, State of Utah, have invented certain new and useful Improvements in Firearms, of which the following is a specification, reference being had to the accompanying drawings, forming a part hereof.

This invention relates generally to automatic breech-loading firearms, and more especially to firearms of this description in which the several operations—such as the unlocking and opening of the breech after firing a shot, the ejection of the empty cartridge-shell, the cocking of the hammer, the presentation and introduction of a new cartridge to the chamber of the barrel, and the closing and locking of the breech—are automatically effected by or through the energy of the recoil of the breech block or bolt carrier or that part which at the time of firing the shot closes the breech or rear end of the cartridge-chamber of the barrel and of the parts connected therewith after each discharge.

The object which I have had in view has been first and mainly the production of a firearm of this class which should be not only practical, efficient, and perfectly safe in use, but should also be very simple in construction and therefore much less liable to get out of order and much less expensive to manufacture than firearms of like general nature but of more complicated construction, such as have been produced or designed hitherto. I have sought also to provide improved means to prevent the release of the hammer until the breech is fully closed and all parts are locked in proper position for the discharge of a cartridge, improved means to prevent the release of the hammer after each single discharge until the trigger has been released and is again operated, and improved means whereby the breech block or bolt carrier is automatically locked in its closed position, so as to prevent the possibility of its movement, by bringing the hammer to the safety or half-cock position and whereby the breech block or bolt carrier is automatically unlocked by bringing the hammer to the full-cock position or by fully lowering the hammer. In attaining these objects the barrel of the firearm is

caused to have a double movement at one and the same time—that is to say, a movement in the direction of its length and simultaneously therewith another movement—the effect of this double movement being to lock or to unlock the breech block or bolt carrier and at the same time to permit the barrel to move to a limited extent with the breech block or bolt carrier, so as to permit the gases of explosion to have their full effect upon the projectile before the breech is unlocked and opened. The breech block or bolt carrier slides to and fro, being impelled in one direction by the energy of the recoil and in the other direction by a reaction-spring, and in its movements it extracts and ejects the empty shell, moves the hammer to the full-cock position, and introduces a fresh cartridge into the chamber of the barrel. In conjunction with other devices the breech block or bolt carrier also operates to prevent the lowering of the hammer until it has closed the breech fully. The lock mechanism is so constructed as to prevent the disengagement of the sear from the hammer after the hammer has been brought automatically to the full-cock position until the trigger is released and is again operated, thereby preventing the discharge of two or more cartridges at each single operation of the trigger, which otherwise would inevitably occur by reason of the swiftness of the automatic operation of the firearm.

Various other features of improvement will be more particularly referred to hereinafter.

I have chosen a pistol as an embodiment of my improvement, and for the purpose of explaining the nature of such improvement I have illustrated in the accompanying drawings and shall refer to and describe hereinafter a magazine-pistol, but it will be understood that I do not intend thereby to restrict my invention to a magazine-pistol nor any other particular kind of firearm, nor even to the combination of the several features of improvement in a single structure.

In the accompanying drawings, wherein I have represented the embodiment of my invention which I have already referred to, Figure 1 is a left-hand side elevation of the pistol with the breech closed and the hammer in the full-cock position. Figs. 2



and 3 are respectively front and rear end views of the same. Fig. 4 is a longitudinal central section of the same with the parts in the same position as in Fig. 1, the barrel and some other parts being shown in elevation. Fig. 5 is a partial view similar to Fig. 4, but with the hammer lowered upon the firing-pin. Fig. 6 is a view similar to Fig. 4, but with the barrel and the breech block or bolt carrier in their extreme rearward positions. Fig. 7 is a partial view similar to Fig. 5, but with the hammer in the half-cock position. Figs. 8 to 17 are detail views of parts to be referred to.

The three main parts of the pistol which I have represented in the drawings are the frame *a*, the barrel *b*, which has a limited double movement, and the breech block or bolt carrier *c*, which slides to and fro under the influence of the recoil and of the reaction-spring. The rear portion of the frame *a* forms the receiver and has a seat and suitable guides for the reciprocating breech block or bolt carrier, and below the receiver is the grip or handle *a'*, which is preferably made integral with the frame, but obviously may be formed separately and attached thereto in any suitable manner. Within the grip and extending through the same upward into the receiver is arranged a seat or chamber for the reception of the cartridge magazine or holder *d*, Figs. 4, 6, and 14 to 17. In the main the cartridge-magazine *d* may be made in any usual or suitable manner, being in effect a sheet-metal tube in which the cartridges are laid one upon another, resting upon a spring-follower *d'*, by which they are pressed upward toward the receiver. The holder is conveniently retained in place within the grip by a spring-actuated latch *d''*. The upper end of the holder is open to permit the escape of the cartridges, the side walls at the rear of this opening being turned in to form ears *d'''*, Figs. 6 to 14, which engage the rim or flange of the topmost cartridge to prevent the escape of the same from the holder except when it is pushed forward, as hereinafter described.

From the receiver the frame *a* is extended forward for the attachment thereto of the barrel *b* and for the reception and support of the reaction-spring. In its normal position the front end of the barrel may project somewhat beyond the extremity of the frame, as clearly shown in Figs. 1 and 4. The top of the frame *a* from end to end is preferably milled off straight, to serve as a guide and slideway for the breech block or bolt carrier *c*, as hereinafter more particularly referred to, and between its edges it is concaved, as may be necessary to form a seat for the barrel when the latter is in its rearmost position. The barrel is attached or connected to the frame in such a manner or by such means as to be capable of limited movement only, but of a double movement within its limits—that is to say, the barrel is free to move to and fro in

the direction of its length and also to have another movement at the same time, such other movement being, in the construction represented in the drawings, a bodily movement toward and from the frame. Obviously the means whereby the barrel is attached or connected to the frame so as to be capable of such movement may be varied considerably. As a convenient means to accomplish the desired purpose I have represented the barrel as provided with two lugs *b'* and *b''*, Figs. 4 and 6, projecting from its under side, one near the muzzle and the other near the breech, corresponding recesses being formed in the frame. Links *b'''* and *b''''* are secured in slots in said lugs and between the walls of said recesses by transverse pivot-pins, so that said links swing freely in the plane of the axis of the barrel. The links are of equal length, and the distance between their points of attachment to the barrel is the same as that between their points of attachment to the frame. Consequently while the barrel moves rearwardly and forwardly and at the same time toward and from the frame the axis of the barrel remains always parallel to its normal position. It will be evident that the forward link may be dispensed with if the barrel is properly guided at its forward end in the frame and that the barrel might be otherwise connected to or supported upon the frame.

The breech block or bolt carrier *c* carries the breech-bolt *c'*, to close the breech or rear end of the chamber of the barrel, is adapted to be engaged by the barrel, to be thereby locked in its closed position, and is also adapted to be engaged by the reaction-spring. Therefore, provided the breech block or bolt carrier is adapted to serve these purposes, it is immaterial what the precise form of the same may be. I prefer, however, that it shall have, forward of the breech-bolt *c'*, a semitubular extension *c''* to inclose the top and sides of the barrel *b*, the breech block or bolt carrier having longitudinal ribs and grooves *c''' c''''* to engage corresponding ribs and grooves *a''' a''''*, formed on the frame *a*, as shown clearly in Figs. 2, 3, and 6, to be thereby held to the frame and guided thereon in its reciprocation.

Near the forward end of the breech block or bolt carrier is a transverse key *c''''*, which is inserted through rectangular recesses cut therefor in the sides of the breech block or bolt carrier and normally projects slightly at each side of the breech block or bolt carrier. A longitudinal mortise or slot *a''''* is cut through the forward part of the frame *a* to receive the key *c''''* and to permit it to travel freely therein. The rear end of said slot or mortise *a''''* forms an abutment for the key *c''''* to limit the rearward movement of the breech block or bolt carrier, and thereby all danger that the breech block or bolt carrier may fly back from the frame is entirely obviated. The key *c''''* also forms the bearing through which the reaction-spring *e* acts upon the breech block or bolt



carrier to return it to its normal position after it has been moved rearwardly therefrom by the recoil. This spring is conveniently located in a chamber  $a^6$ , formed in the forward extension of the frame, and at its rear end bears against the rear end of said chamber. At its forward end the said spring may have a piston  $e'$ , which is provided with a head or flange  $e^2$  to bear against the key  $c^5$ . The rear face of the key  $c^5$  is recessed, as at  $c^6$ , (see Figs. 12 and 13,) to receive the head or flange  $e^2$ , whereby said piston forms a latch to prevent the accidental displacement of said key  $c^5$ . When it is desired to withdraw said key  $c^5$  to permit the removal of the breech block or bolt carrier from the frame, a pin is inserted through the hole  $a^7$  into the path of said piston  $e'$  to stop its forward movement, while the forward movement of the breech block or bolt carrier is continued, thereby releasing the key from the piston and permitting it to be withdrawn readily. The piston  $e'$  is preferably tubular to receive a spring  $e^3$ , which bears at its forward end against an internal shoulder  $e^4$  and projects rearwardly somewhat beyond the rear end of said piston, so that when the breech block or bolt carrier and the piston move rearwardly, compressing the reaction-spring  $e$ , the end of the spring  $e^3$ , which is quite stiff, strikes the solid partition at the end of the chamber  $a^6$  and serves as a buffer or cushion to diminish the shock. In order to permit the introduction of the reaction-spring  $e$  and piston  $e'$ , the forward end of the chamber  $a^6$  is left open and is closed after the introduction of the spring and piston by a plug  $a^8$ , which may be secured in place by the pin  $a^9$ , which serves as the pivot for the forward link  $b^3$ . It will be evident that the piston might be dispensed with, if desired, the terminal coil of the spring taking its place as a latch for the key  $c^5$ .

Just forward of the breech-bolt  $c'$  the top of the breech block or bolt carrier  $c$  is cut away, as at  $c^7$ , to permit the ejection of the empty shell after each discharge, the said opening  $c^7$  being directly over the upper end of the cartridge-holder  $d$  when the breech block or bolt carrier is in its extreme rearward position, and standing over the rear portion of the barrel when the breech block or bolt carrier is in its extreme forward or closed position. Just forward of the opening  $c^7$  the breech block or bolt carrier is provided with one or more recesses  $c^8$  to receive corresponding transverse ribs or projections  $b^5$  on the barrel  $b$ , the said ribs or projections being caused to enter and occupy said recesses by the movement in the transverse or vertical plane which the barrel has at the same time that it is moved forward in a longitudinal direction by the breech block or bolt carrier during the last of the forward movement of the latter, whereby the breech block or bolt carrier is securely locked to the barrel and the breech-bolt is held rigidly against the end of the barrel, closing the breech. In this

closed position, therefore, the breech block or bolt carrier  $c$  and the barrel  $b$  are securely interlocked and neither one can move independently of the other. When, however, the breech block or bolt carrier is moved rearwardly under the influence of the recoil, the barrel moves for some distance with it until the rocking movement of the barrel heretofore explained lowers the barrel until it rests upon the frame, and thereby withdraws the ribs  $b^5$  from the recesses  $c^8$  in the breech block or bolt carrier and releases the breech block or bolt carrier from the barrel. The frame prevents further rearward movement of the barrel, which is left with its breech in proper position with respect to the cartridge-magazine to receive a fresh cartridge after the empty shell has been withdrawn. The continued rearward movement of the breech block or bolt carrier opens the breech by moving the breech-bolt away from the barrel until the face of the breech-bolt has passed to the rear of the cartridge-magazine. During the return or forward movement of the breech block or bolt carrier the barrel is kept from moving forward with it by the top of the breech block or bolt carrier, which slides over the ribs  $b^5$  and prevents the barrel from rising from the frame, but as the last of the closing movement brings the face of the breech-bolt  $c'$  against the breech of the barrel the recesses  $c^8$  arrive above the ribs  $b^5$ , permitting the barrel to rise as the ribs enter the recesses and at the same time to be pushed forward by the breech block or bolt carrier, so that when the breech block or bolt carrier and the barrel arrive at their forward or closed position they are again securely locked, as before. In order to delay somewhat the unlocking of the barrel and breech block or bolt carrier, so as to insure the exit of the projectile from the muzzle of the barrel, and the consequent relief of the pressure of the powder-gases in the barrel before the breech block or bolt carrier is unlocked and the breech opened, I arrange the links  $b^3 b^4$  so that in the closed position of the breech block or bolt carrier the centers of the upper pivots between the links and the barrel stand somewhat forward of a vertical line through the centers of the lower pivots between the links and the frame. By this arrangement the barrel moves rearward with the breech block or bolt carrier for some distance before it moves downward, the ribs are kept in the recesses, and the unlocking of the breech block or bolt carrier from the barrel is correspondingly delayed.

The device just described is not only simple, but exceedingly effective for the purpose named, requiring no nice adjustment and not being injuriously affected by wear, the only effect of which will be to increase the delay.

As described heretofore, the cartridges are pressed upward from the holder, but are held from escaping therefrom by the ears  $d^3$ . Nevertheless the rim of the topmost cartridge rises, so as to project above the holder as soon



as the breech-bolt  $c'$  has passed to the rear of the holder, the action of the spring-follower in the magazine and of the cartridges upon one another causing the forward end of the topmost cartridge to be tilted up and directed toward the breech of the barrel. In the forward or closing movement of the breech block or bolt carrier the face of the breech-bolt  $c'$  engages the topmost cartridge, the upper edge of which then lies in the path of the breech-bolt and pushes it directly from the holder into the chamber of the barrel, the lug  $b^2$  on the under side of the barrel projecting somewhat beyond the rear end thereof and having its upper face inclined rearwardly and downwardly to serve as a guide for the cartridge.

It will be understood that when the breech is closed and the barrel and breech block or bolt carrier are locked together the lock mechanism can be released by pressure upon the trigger to effect the discharge of the cartridge. By the energy of the recoil the breech block or bolt carrier is driven to the rear, and in its movement after it is released from the barrel it effects the extraction of the empty shell from the chamber of the barrel and its ejection from the receiver. For this purpose an extractor  $f$ , of usual construction and acted upon by a spring  $f'$ , as usual, is arranged in the breech-bolt  $c'$  to engage the head or flange of the cartridge during the closing movement and to extract the shell from the chamber of the barrel during the opening movement. As the shell is drawn rearwardly by the extractor, which engages its upper edge, its lower edge strikes two projections  $g$ , which are preferably formed on or secured to the sides of the cartridge-holder near the upper rear corners in similar position, as shown in Figs. 15, 16, and 17, so as to be removed therewith. These projections stop the rearward movement of the lower portion of the shell while its upper edge is still engaged by the extractor, with the result that the shell is snapped out or ejected through the opening  $c^7$  in the top of the breech block or bolt carrier. The under side of the breech-bolt  $c'$  is of course provided with grooves  $c^9$ , Fig. 8, corresponding to the stops or projections  $g$ .

The breech-bolt  $c'$  is provided with the usual firing-pin  $k$  and retracting-spring  $k'$ , and the hammer  $l$  is pivoted, as usual, in the frame and is acted upon by the usual mainspring  $l'$ , the shape and position of the hammer being such that it is struck and brought to full-cock position by the breech-bolt  $c'$  in the rearward or opening movement of the latter. The sear  $m$  is pivoted in the frame in front of the hammer and is normally acted upon by a spring  $m'$  to cause it to engage the hammer and keep it cocked. The trigger  $n$  is pivoted, as usual, in the frame in front of the grip  $a'$ , and its rearward movement is transmitted to the sear by a connecting-piece  $n'$ , Figs. 4, 5, and 11. The front end of the latter is supported in a horizontal opening in the front wall of the magazine-seat and rests against

the trigger. In rear of this the piece  $n'$  is divided into two arms, which pass around the cartridge-holder without interfering with the same and in rear of it are united by a cross-bar  $n^2$ . The rear face of the cross-bar  $n^2$  is beveled and the spring  $n^3$ , bent rearwardly at its upper end, bears against the cross-bar  $n^2$ , tending to raise it into the path of the sear  $m$  and to yieldingly hold the connecting-piece  $n'$  and the trigger  $n$  in their forward positions. Upon the top of the cross-bar  $n^2$  is a lip or shoulder  $n^4$ , adapted to engage the extremity of the sear, so that the rearward movement of the trigger  $n$  may be communicated to the sear to cause it to release the hammer  $l$  when the trigger is operated. In order to prevent the release of the hammer unless the breech is fully closed, a safety-piece  $o$  is arranged between the breech-bolt  $c'$  and the connecting-piece  $n'$ . The top of the safety-piece  $o$  is guided in a hole in the frame adjacent to the breech-bolt and projects into a recess  $c^{10}$  in the latter when the breech is fully closed. The lower portion of the safety-piece  $o$  passes through a slot  $m^2$  in the sear  $m$  and is itself slotted, as at  $o'$ , to straddle the pin upon which the sear is pivoted, so that the longitudinal or vertical movement of the safety-piece is limited by said pin. The length of the safety-piece  $o$  is such that when its upper end stands in the recess  $c^{10}$  of the breech-bolt its lower end permits the cross-bar  $n^2$  of the connecting-piece  $n'$  to be raised by the spring  $n^3$  into position to engage the sear  $m$ . As soon as the breech-bolt commences to move rearwardly the inclined forward end of the recess  $c^{10}$  forces the safety-piece downward against the pressure of the spring  $n^3$  and depresses the cross-bar  $n^2$  below the end of the sear  $m$ , so that even if the trigger is pressed when the breech block or bolt carrier is out of its closed position the sear cannot be operated thereby, and the sear is at all times, except when the breech is closed and the trigger is pressed, free to re-engage the hammer as soon as it is cocked, even though the trigger has not been released. The sear  $m$  and safety-piece  $o$  also serve to automatically lock the breech-bolt in the frame when the hammer is brought to half-cock and to automatically unlock the same when the hammer is either lowered or raised to full-cock. For this purpose the safety-piece has at its lower end a shoulder  $o^2$ , (see Figs. 4, 5, 6, 7, and 10,) and the sear  $m$  has a cross-bar  $m^3$  below its slot  $m^2$ , which forms a shoulder to cooperate with the shoulder  $o^2$  of the safety-piece  $o$ .

As is well understood, the point or upper end of the sear  $m$  approaches the center upon which the hammer is pivoted more nearly when the hammer is at half-cock than when it is down or at full-cock, wherefore the cross-bar or shoulder  $m^3$ , when the hammer is at half-cock, (see Fig. 7,) is thrown forward under the shoulder  $o^2$  of the safety-piece  $o$  and prevents the latter from moving downward.



As the breech-bolt *c'* cannot move rearward unless the safety-piece *o* yields downward, the locking of the safety-piece in this manner holds the breech-bolt in its closed position.

5 When the hammer is raised or lowered out of the half-cock position, it forces the point of the sear forward, thereby withdrawing the cross-bar or shoulder *m*<sup>3</sup> from beneath the shoulder or end *o*<sup>2</sup> of the safety-piece *o*, permitting the latter to be moved downward and  
10 the breech-bolt, therefore, to be moved rearward. The spring *n*<sup>3</sup> is conveniently formed as the middle leaf or member of a single spring-plate, which is trifurcated and whose  
15 outer leaves or members *m'* bear upon the sear. This spring-plate may also be secured to the latch *d*<sup>2</sup> for the cartridge-holder, and thereby operate the latter without requiring an additional spring.

20 The operation of the firearm described herein will now be readily understood. A charged cartridge-holder is inserted in its seat in the grip of the frame and the breech block or bolt carrier is drawn rearward once by hand.  
25 This unlocks the barrel, opens the breech, cocks the hammer, and presents a cartridge in front of the breech-bolt. When the breech block or bolt carrier is released, the reaction-spring moves the parts forward and closes and  
30 locks the breech after transferring a cartridge to the barrel, thus placing all parts in position for firing. If, now, the trigger is pulled, a shot will be fired and the recoil will effect the opening movement, extracting and ejecting the  
35 empty shell and storing energy in the reaction-spring for the subsequent movement of the parts in transferring a cartridge to the barrel and closing and locking the breech. These operations may be repeated as often as  
40 cartridges are supplied. The movements of the parts take place so rapidly, that unless means were provided to prevent, the trigger could not be released before several shots in succession would be fired; but, as already  
45 explained, the trigger is at each opening movement of the breech disconnected from the sear, thus releasing the latter and allowing it to reengage the hammer as soon as the same is again cocked, even though the trigger has  
50 not been released. By reason of the construction and arrangement of parts which I have devised and explained herein I am enabled to make the frame of the barrel of so light a weight that the breech block or bolt  
55 carrier may be of considerable weight, whereby the momentum of the heavy breech block or bolt carrier enables it to continue the opening movement after the pressure of the gases in the barrel has been released and after the  
60 barrel has been stopped and to store energy in the reaction-spring.

It will be evident that various features of this invention may be employed independently of the rest and in hand-operated or other  
65 firearms of a different kind from that which I have described herein, and that various changes in the form and arrangement of the

parts may be made without departing from the spirit of my invention.

What I claim, and desire to secure by Letters Patent, is—

1. In a firearm, the combination with a frame and a movable breech block or bolt carrier, of a barrel having a limited movement in the direction of its length and in a transverse direction to lock and unlock said breech block or bolt carrier. 75

2. In a firearm, the combination with a frame, of a breech block or bolt carrier mounted to slide upon said frame, a barrel having a limited movement upon said frame, and a projection carried by said barrel and caused by the movement thereof to engage said breech block or bolt carrier. 80

3. In a firearm, the combination with a frame, of a breech block or bolt carrier mounted to slide upon said frame, a barrel having a limited longitudinal movement and a limited transverse movement upon said frame and a projection carried by said frame and caused by said transverse movement to enter or leave a recess in said breech block or bolt carrier. 85 90

4. In a firearm, the combination with a frame and a breech block or bolt carrier sliding on the frame, of a barrel connected to said frame to have a longitudinal movement and a movement toward and from said frame and means for interlocking said barrel and said breech block or bolt carrier by the movement of said barrel from said frame. 95 100

5. In a firearm, the combination with a frame and a breech block or bolt carrier sliding on said frame, of a barrel, a link connection between said barrel and said frame, whereby said barrel may move longitudinally and toward and from said frame, and means for interlocking said barrel and said breech block or bolt carrier by the movement of said barrel from said frame. 105 110

6. In a firearm, the combination with a frame and a breech block or bolt carrier sliding on said frame, said breech block or bolt carrier having a transverse groove, of a barrel, a link connection between said barrel and said frame whereby said barrel may move longitudinally and toward and from said frame, and a projection fixed on said barrel to enter the groove in said breech block or bolt carrier as said barrel is moved from the frame. 115 120

7. In a firearm, the combination with a frame, of a breech block or bolt carrier sliding on said frame, said breech block or bolt carrier comprising a breech-bolt and a forward extension embracing said frame, and a barrel mounted upon said frame within said forward extension and having a limited movement upon said frame to move with and to lock and unlock said breech block or bolt carrier. 125 130

8. In a firearm, the combination with a frame having a forward extension, a reaction-spring mounted in said forward extension, and a barrel, of a breech block or bolt carrier



having a semitubular, forward extension to inclose the barrel and to engage said frame and to slide thereon, said frame having a longitudinal slot in its forward extension, and a key carried by the forward extension of said breech block or bolt carrier and traveling in said slot to form a bearing for said reaction-spring.

9. In a firearm, the combination with a frame, and a reaction-spring mounted in said frame, of a breech block or bolt carrier formed to engage said frame and to slide thereon, said frame having a longitudinal slot, and a key carried by said breech block or bolt carrier and traveling in said slot to form a bearing for said reaction-spring and arranged to be held by said spring from accidental displacement.

10. In a firearm, the combination with a frame, a reaction-spring mounted in said frame, and a piston carried by the free end of said spring, of a breech block or bolt carrier formed to engage said frame and to slide thereon, said frame having a longitudinal slot, and a key carried by said breech block or bolt carrier and traveling in said slot to form a bearing for said reaction-spring, said key being recessed to receive the head of said piston.

11. In a firearm, the combination with a frame adapted to receive a magazine, of a barrel, a link connection between said barrel and frame, whereby said barrel may move toward said frame to present its breech end in position to receive a cartridge from the magazine, and a sliding breech-bolt to push the cartridge from the magazine into said barrel.

12. In a firearm, the combination with a frame and a cartridge-holder supported in the frame and having a spring-follower to feed the cartridges toward the receiver of the frame, of a breech-piece sliding on said frame, said breech block or bolt carrier comprising a breech-bolt and a forward extension, a barrel having a link connection with said frame, and means whereby said barrel may engage said breech block or bolt carrier, whereby as the breech block or bolt carrier and barrel move rearwardly the movement of the barrel is interrupted and a cartridge is presented in position for insertion into the barrel, and as the breech block or bolt carrier moves forward the breech-bolt engages the cartridge, inserts it into the barrel, returns the barrel to normal position, and is at the same time locked to said barrel.

13. In a firearm, the combination with a frame and a barrel mounted on said frame, of a breech block or bolt carrier sliding on said frame, said breech block or bolt carrier comprising a breech-bolt and a forward, semitubular extension to cover the barrel and having an opening forward of the breech-bolt to permit the ejection of the shell.

14. In a firearm, the combination with a frame and a barrel connected to said frame to have a limited double movement thereon, of a breech block or bolt carrier sliding on said frame, said breech block or bolt carrier comprising a breech-bolt and a forward extension therefrom to cover said barrel, means to engage said breech block or bolt carrier and said barrel and shell-extracting and shell-ejecting devices carried by said breech block or bolt carrier and said frame and operated by the movements of said breech block or bolt carrier.

15. In a firearm, the combination with a frame adapted to receive a magazine, and a barrel, of a sliding breech block or bolt carrier mounted on said frame, an extractor mounted on said breech block or bolt carrier to engage one edge of the cartridge-flange, and a magazine independent of the frame and having lugs or ears at the rear of the magazine in the path of the cartridge-shell as it is withdrawn from the barrel by the extractor, whereby the rearward movement of the shell is arrested and the shell is ejected.

16. In a firearm, the combination with a frame and a lock mechanism, of a breech block or bolt carrier sliding on said frame and having a recess, and a safety-piece mounted in the frame to control said lock mechanism and entering said recess in said breech block or bolt carrier and permitting the release of the lock mechanism when the breech block or bolt carrier is in the firing position.

17. In a firearm, the combination with a frame, a hammer and a sear, a trigger and a connecting-piece to operate said sear, of a breech block or bolt carrier sliding on said frame and having a recess, and a safety-piece entering said recess in said breech block or bolt carrier when the latter is in firing position and permitting the operation of the sear and its movement by said breech block or bolt carrier as it moves from the firing position to disconnect said trigger from said sear.

18. In a firearm, the combination with a frame, a hammer having a half-cock notch and a full-cock notch, a sear engaging said notches and having a shoulder, a breech block and bolt carrier sliding on said frame and having a recess, and a safety-piece mounted in said frame and entering said recesses when the hammer is at half-cock and having a shoulder which engages said shoulder of said sear, whereby when said hammer is at half-cock said safety-piece is held by said sear in engagement with said breech block or bolt carrier.

This specification signed and witnessed this 17th day of October, A. D. 1896.

JOHN M. BROWNING.

In presence of--  
MATTHEW S. BROWNING,  
M. J. HALL.