

(No Model.)

P. LORANG WRENCH.

No. 554,284.

Patented Feb. 11, 1896.

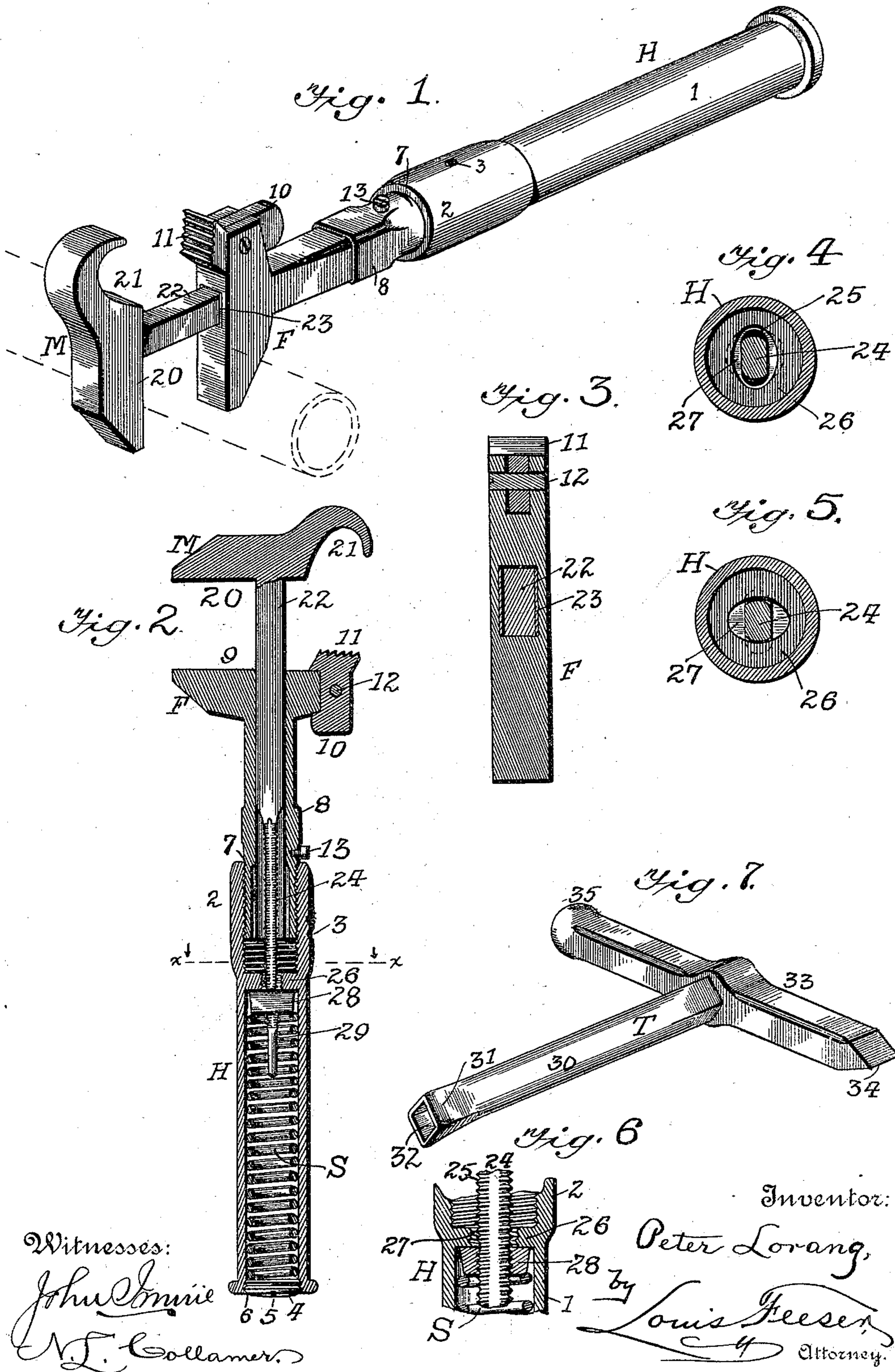

Witnesses:
John Connie
A. J. Collamer.

Inventor:
Peter Lorang,
 by *Louis Keeser,*
 Attorney.

UNITED STATES PATENT OFFICE.

PETER LORANG, OF JORDAN, MINNESOTA, ASSIGNOR OF ONE-HALF TO
JACOB LAZARUS.

WRENCH.

SPECIFICATION forming part of Letters Patent No. 554,284, dated February 11, 1896.

Application filed November 4, 1895. Serial No. 567,802. (No model.)

To all whom it may concern:

Be it known that I, PETER LORANG, a citizen of the United States, residing at Jordan, in the county of Scott, State of Minnesota, have
5 invented certain new and useful Improvements in Wrenches, whereof the following is a specification.

This invention relates to wrenches, and more especially to that class thereof which
10 employ a movable jaw, and the object of the same is to effect certain improvements in devices of this character.

To this end the invention consists in the details of construction hereinafter more fully
15 described, and as illustrated in the drawings, wherein—

Figure 1 is a perspective view of the device complete. Fig. 2 is a central longitudinal section thereof. Fig. 3 is an enlarged cross-section through the fixed jaw. Figs. 4 and
20 5 are sections on the line *xx* of Fig. 2, showing the handle as in different positions quartering to each other. Fig. 6 is an enlarged longitudinal section through the partition in
25 the handle. Fig. 7 is a perspective detail of a tool which is used for separating and connecting the parts of this wrench.

This wrench comprises in general a handle H, a fixed jaw F, a movable jaw M, and a
30 spring S within the handle for opening said movable jaw. With the exception of the specific details described below these various parts are of any desired construction, and their sizes, shapes, and materials may be
35 varied at will without affecting the vital principles of this invention.

The handle H comprises a tubular body 1, preferably slightly enlarged at its upper end, as at 2, and provided exteriorly with an indicating-mark 3, while its lower end is closed
40 by a removable plug 4, preferably provided with a notch 5, so that it can be turned by a screw-driver and threaded on its edges to engage threads 6 in this end of the handle.

This plug serves as a means to adjust the tension of the spring S. The enlarged portion 2 is interiorly threaded, as seen, so as to engage at 7 with threads on the exterior of the shank 8 of the fixed jaw F. The said
50 shank is tubular, as seen in Fig. 2, and at its upper end carries the jaw proper, 9, which

may have at one side a piece 10, provided with a notched face 11, and pivoted, as at 12, for use when the wrench is to grasp a cylindrical surface. The shank 8 is furthermore provided with an indicating-mark, such as a
55 screw 13, for a purpose to appear below.

The movable jaw M consists of the jaw proper, 20, preferably dished at one side, as at 21, to work in conjunction with the notched
60 face 11, and having a rectangular shank 22 passing between springs 23 in the fixed jaw and extending out through the same. The lower end of this shank 22 is made oval, as best seen at 24 in Figs. 4 and 5, and is
65 threaded, as at 25, on its two sides farthest remote from its axis. 26 is a partition within the handle H, preferably between the parts 1 and 2 thereof, and this partition is provided with an oval hole 27, interiorly threaded, and
70 of a size and shape to permit the oval portion 24 of the shank to slide therethrough, as in Fig. 4, or to engage with its threads when the handle H is turned for a quarter-revolution, as in Fig. 5.

28 is a nut of a size to pass into the tubular handle H, and its threads engage those lettered 25 on the shank 24, and the extreme lower end of the shank is reduced, as at 29.

S is an expansive spring within the tubular handle H, between the nut 28 and the
80 plug 4.

The tool T illustrated in Fig. 7 and intended for use with this wrench consists of a shank 30, having one end 31 exteriorly
85 rounded and of a size to pass into the handle H, while in the end is a socket 32 of a size to engage the nut 28. The head 33 of this T-shaped tool has at one end a screw-driver point 34, and the other end may be provided
90 with a hammer 35.

With the above construction of parts, the operation of my improved invention is as follows: The threaded portion of the fixed jaw F is screwed at 7 into the upper end of the
95 handle, the lower end of the shank of the movable jaw M is passed down through the fixed jaw and through the aperture in the partition 26 of the handle, the nut N is inserted in the socket 32 of the tool T, passed
100 into the open lower end of the handle, and secured onto the threads 25 of the shank 24. The

tool is then withdrawn, the spring S is inserted within the handle, and finally the plug is screwed in place by the point 34 of the tool to hold the spring in place and under the desired tension. The wrench is then ready for use. Grasping the shank 8 of the fixed jaw in one hand and the handle II in the other hand these two parts are turned until the marks 3 and 13 are in alignment. Such rotation of the handle turns the partition 26 around the threaded shank 24 until the latter is free from the threads of the former, as seen in Fig. 4, and the expansive force of the spring S bearing on the nut 28 then shoots the movable jaw M outward until said nut strikes the partition 26, as seen in Figs. 2 and 6, which striking limits the outward movement of the jaw M and prevents its displacement. It will be obvious that the nut can be set upon the shank 24, and that the fixed jaw may be screwed for a considerable distance into the handle, both of which motions would permit the two jaws to open to a greater degree when large nuts are to be turned by this wrench. The movable jaw having been projected by the spring S, as seen in Fig. 2, the mouth of the wrench is placed over the nut and the movable jaw pushed down until the nut is clamped between the two jaws. Then, still holding the shank 8 with one hand, the handle II is turned with the other hand so that the oval hole 27 in the partition 26 stands as seen in Fig. 5 and the threads in such hole engage the threads 25 on the shank of the movable jaw and lock the latter in position. The wrench can then be moved to turn the nut as desired. After turning the nut the two marks 3 and 13 are again put in alignment by turning the handle, when the movable jaw will spring out to its former position.

What is claimed as new is—

1. In a wrench, the combination with a tubular fixed jaw, and a movable jaw having a shank sliding through but not rotating within the fixed jaw, the lower portion of said shank being reduced, made oval, and threaded; of a tubular handle rotatively connected with the fixed jaw, a partition within said handle having an oval threaded hole of a size to

release said threaded shank when the hole and shank are concentric, a stop on the threaded shank below said partition, an expansive spring within the handle below said stop, and a plug screwed into the lower end of the handle and standing against the opposite end of said spring so as to permit the adjustment of the latter, as and for the purpose set forth.

2. In a wrench, the combination with a fixed jaw having a rectangular longitudinal opening, its lower end being provided with exterior threads, and a movable jaw having a rectangular shank sliding through said opening and having its lower end reduced, made oval, and threaded; of a tubular handle having a partition provided with an oval threaded hole of a size to free said threaded shank when the hole and shank are concentric, threads within the handle above said partition engaging those on the shank of the fixed jaw, a stop on the shank of the movable jaw below the partition, and an expansive spring in the lower end of the handle pressing said stop normally toward the partition, as and for the purpose set forth.

3. In a wrench, the combination with a fixed jaw having a rectangular longitudinal opening, its lower end being provided with exterior threads, and a movable jaw having a rectangular shank sliding through said opening and having its lower end reduced, made oval, and threaded; of a tubular handle having a transverse partition provided with an oval threaded hole of a size to free said threaded shank when the hole and shank are concentric, threads within the handle above said partition engaging those on the shank of the fixed jaw, a nut on the threaded shank of the movable jaw below the partition, and an expansive spring in the lower end of the handle pressing said nut normally toward the partition, as and for the purpose set forth.

In testimony whereof I have hereunto set my hand in presence of two subscribing witnesses.

PETER LORANG.

Witnesses:

JACOB LAZARUS,
G. SIEGENTHALER.