

G. B. SELDEN.
ROAD ENGINE.

No. 549,160.

Patented Nov. 5, 1895.

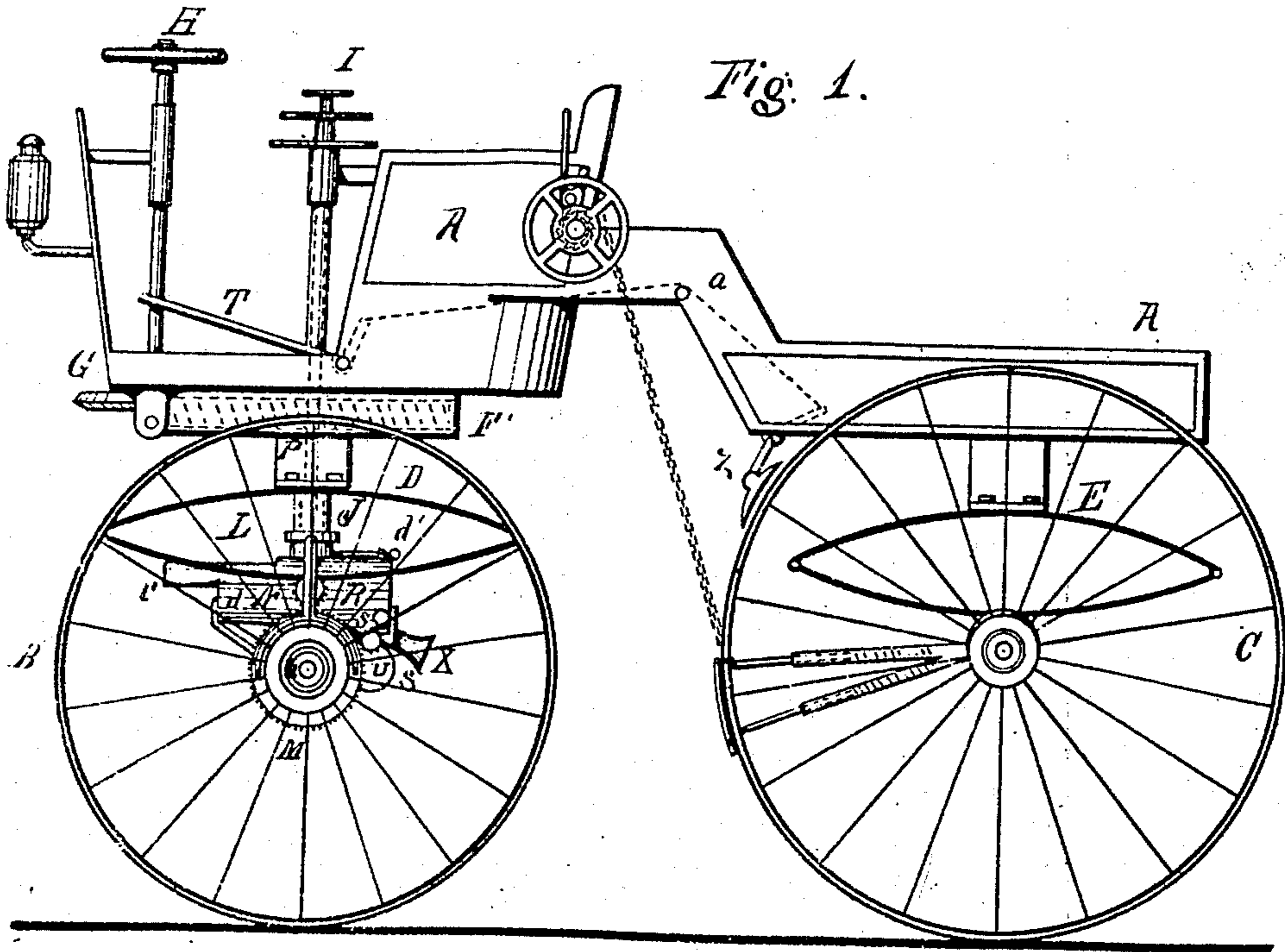

Fig. 1.

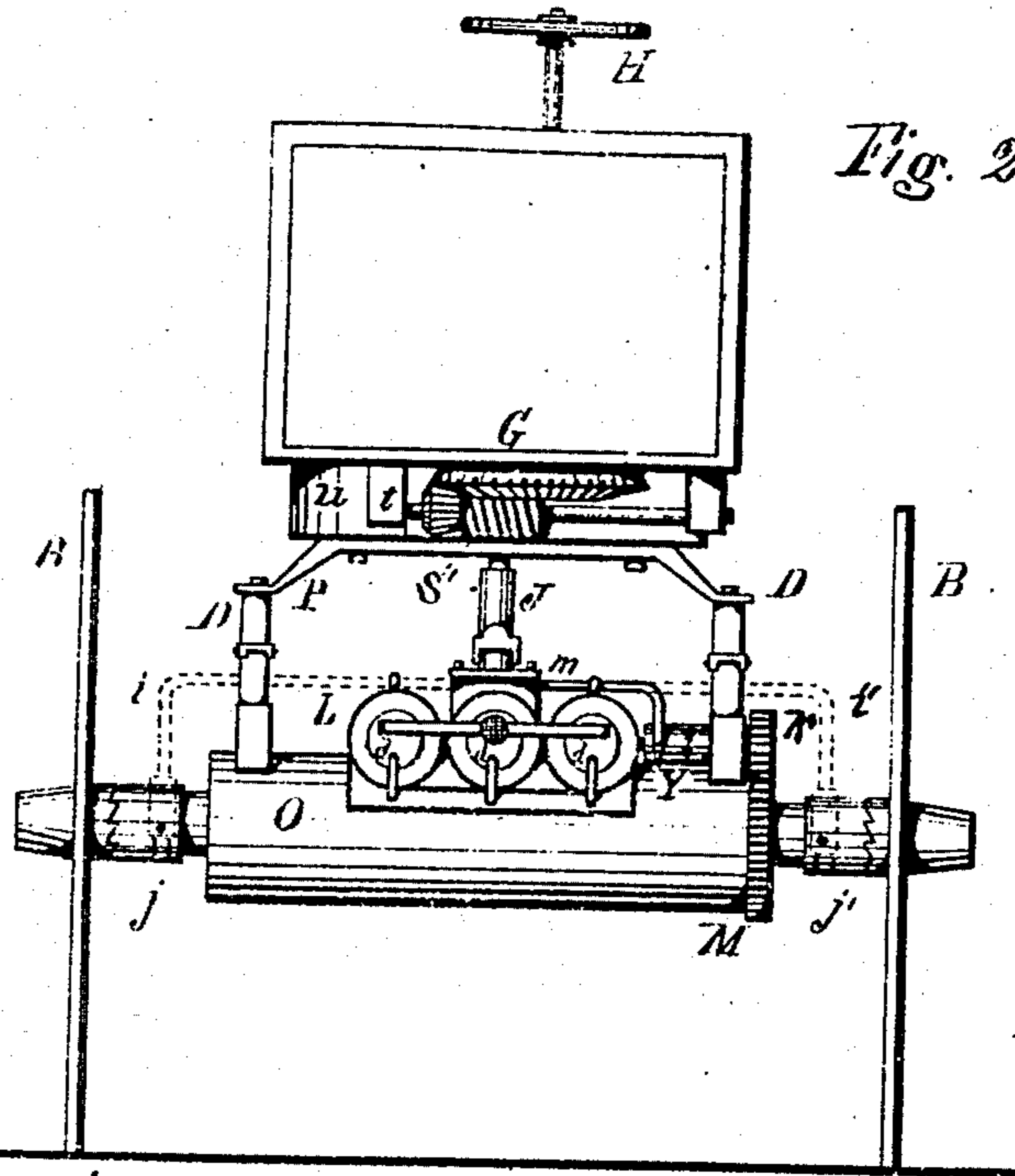

Fig. 2.

WITNESSES
W. M. Kellogg, Jr.
Geo. Eastman

INVENTOR
Geo. B. Selden

G. B. SELDEN.
ROAD ENGINE.

No. 549,160.

Patented Nov. 5, 1895.

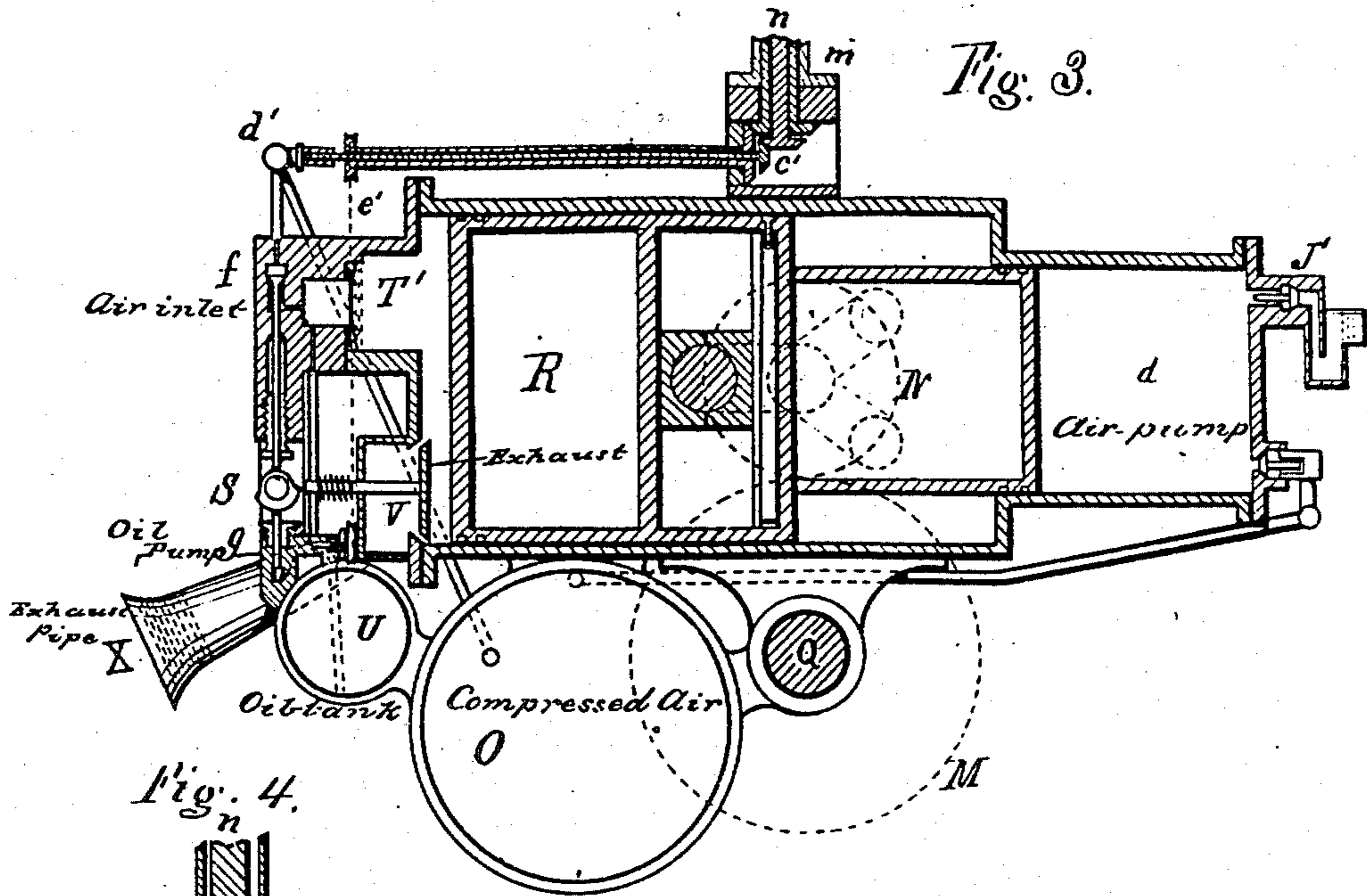

Fig. 3.

Fig. 4.

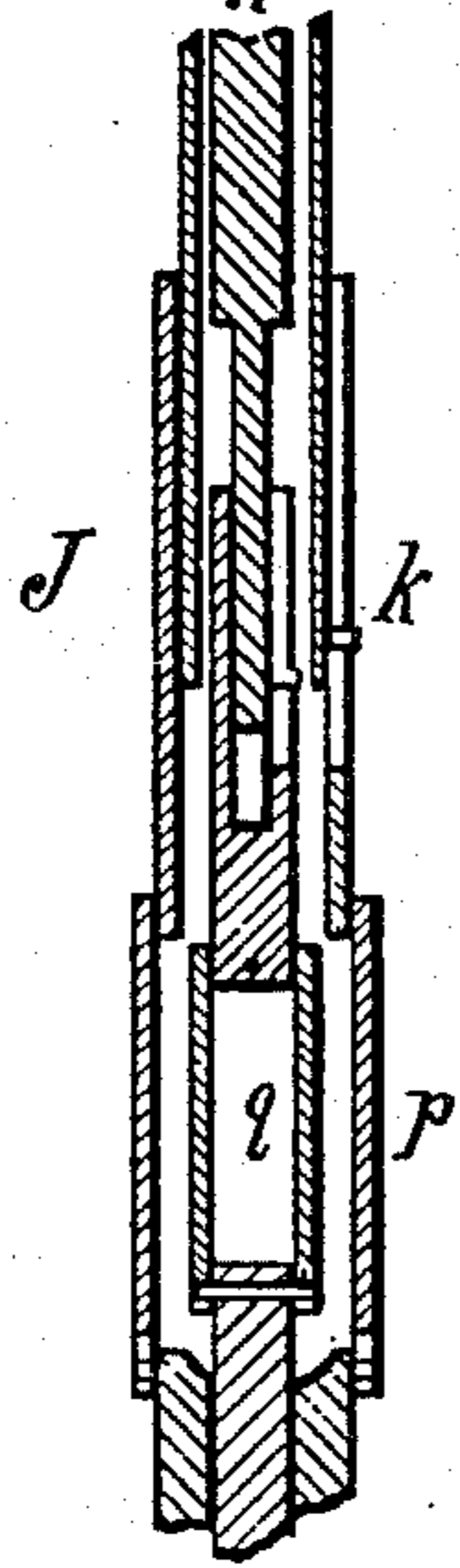
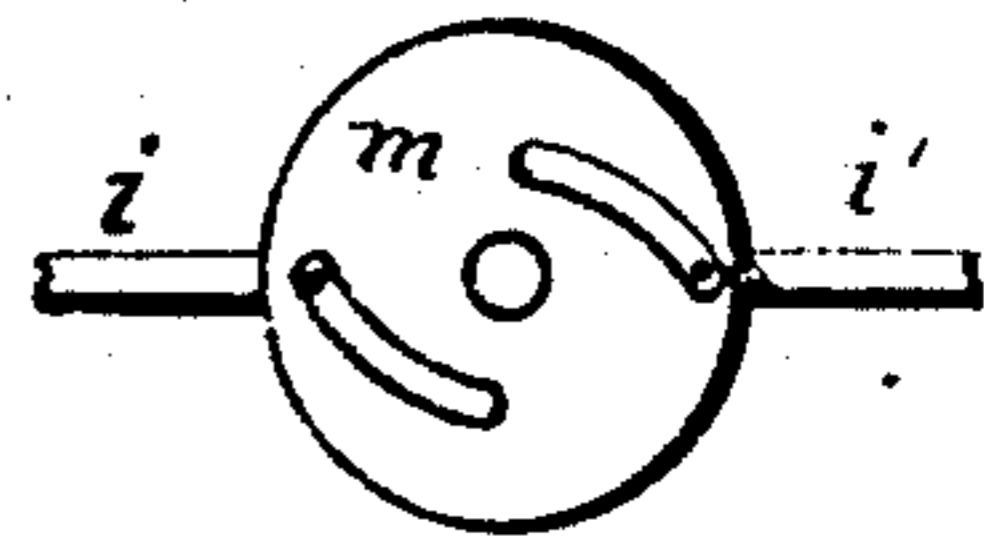

Fig. 5.



WITNESSES
Wm. Rebas, Jr.
Geo. Eastman

INVENTOR
Geo. B. Selden

UNITED STATES PATENT OFFICE.

GEORGE B. SELDEN, OF ROCHESTER, NEW YORK.

ROAD-ENGINE.

SPECIFICATION forming part of Letters Patent No. 549,180, dated November 5, 1895.
Application filed May 8, 1879.

To all whom it may concern:

Be it known that I, GEORGE B. SELDEN, a citizen of the United States, residing at Rochester, in the county of Monroe, in the State of New York, have invented an Improved Road-Engine, of which the following is a specification, reference being had to the accompanying drawings.

The object of my invention is the production of a safe, simple, and cheap road-locomotive light in weight, easy to control, and possessed of sufficient power to overcome any ordinary inclination.

The difficulties heretofore encountered in the application of steam to common roads are the great weight of the boiler, engine, water, and water-tanks, the complicated apparatus necessary to adapt the machine to the roughness of the roads which it must traverse, the necessity of the attendance of a skilled engineer to prevent accidents, and the unsightly appearance of the locomotives built on this plan. I have succeeded in overcoming these difficulties by the construction of a road-locomotive propelled by a liquid-hydrocarbon engine of the compression type, of a design which permits it to be operated in connection with the running-gear, so that the full carrying capacity of the body of the vehicle can be utilized for the transport of persons or goods, and which, by dispensing with skilled attendance and with steam-boilers, water, water-tanks, coal, and coal-bunkers, very largely reduces the weight of the machine in proportion to the power produced and enables me, while employing the most condensed form of fuel, to produce a power road-wagon which differs but little in appearance from and is not materially heavier than the carriages in common use, is capable of being managed by persons of ordinary skill at a minimum of trouble and expense, and which possesses sufficient power to overcome any usual inclination.

My improved road-engine is represented in the accompanying drawings, in which—

Figure 1 is a side elevation. Fig. 2 is a front elevation. Fig. 3 is a vertical section through my improved hydrocarbon-gas engine. Fig. 4 is a vertical section through the flexible valve connections. Fig. 5 represents the slotted plate for operating the clutch or clutches.

A A, Fig. 1, is the body of my improved road-locomotive, which may be of any ordinary or desired form, with any number of seats and with or without a top.

B B are the driving-wheels, which are of any usual construction, and C the trailing wheels.

D and E are respectively the springs of the two pairs of wheels.

F is the fifth-wheel, to which the springs D are connected.

G is the steering device, and H the hand-wheel for operating the same. Z is a brake, which is controlled by a cord running forward to the foot-lever T.

The liquid-hydrocarbon-gas engine J, may be connected with either the steering or trailing wheels; but I prefer to drive the steering-wheels in vehicles of the type represented in the accompanying drawings. The most convenient way of arranging the cylinders of the liquid-hydrocarbon engine is transversely to the driving-shaft, as shown in the drawings. The gas-engine is provided with a power-shaft carrying a pinion N, meshing into the gear M, fixed to the driving-axle. By attaching the cylinders, which may be of any convenient number, to the air-reservoir O, Figs. 2 and 3, which is a shell closed at each end and arranged parallel to the driving-shaft, a compact arrangement is obtained. If the driving-shaft passes through the air-reservoir, it should pass through a tube secured to the heads at each end in order to avoid stuffing-boxes. Journals for the driving-shaft may be formed on the heads of the air-reservoir, or where the shaft is located outside of the reservoir, as in Fig. 3, the gas-engine is connected with the shaft by suitable boxes. The springs D are attached at their lower sides to the air-reservoir or to a frame connecting the journals on the driving-shaft and the engine. In the construction shown in Figs. 1 and 2 a portion of the upper side of the air-reservoir is removed and the cylinders of the gas-engine are cast in one piece with a curved flange which is riveted over the top of the air-reservoir. On their upper sides the springs D are connected with a frame P, which is fastened to the worm-gear constituting the fifth-wheel F.

Any form of liquid-hydrocarbon engine of the compression type may be employed in my improved road-locomotive.

In the accompanying drawings I have represented an engine of the type in which air is compressed into a reservoir *O* by an air-pump *d*. Fig. 3, from which it is admitted to the working cylinder *R*, by a valve *f*, operated by a cam-shaft *S*, along with a given quantity of a liquid hydrocarbon injected by pump *g* from the tank *U* into the combustion-chamber *T*, the products of combustion, after expansion, being exhausted through valve *V*, opened by the cam-shaft *S*.

Fig. 3 is a central vertical section of the working cylinder and air-pump, and in which for convenience of illustration the combustion-chamber, air-valve, pump, and exhaust-valve are represented in the same plane. It will be understood that in the three-cylindered engine shown each working cylinder is provided with suitable admission-valves and combustion apparatus and that the cranks are preferably arranged at equal angles with each other.

As the general construction and mode of operation of liquid-hydrocarbon engines of this class are now well known, it is considered unnecessary to further describe them here. The inlet-valve *J'* of the air-pump is provided with a dust-strainer composed of fine wire-gauze, cloth, or other material for preventing the entry of dust into the apparatus, and a bend in the entry-pipe may be filled with a liquid either with or without an absorbent material to further purify the entering air from floating particles.

X is the exhaust-pipe through which the products of combustion are discharged underneath the body.

The cam-shaft *S* is driven by the gear *M* on the axle of the driving-wheels. The gears should all be boxed in to exclude dust. A clutch *Y*, Fig. 2, may be interposed between the engine and the gearing *M N* to disconnect it from the same, in which case the cam-shaft *S* should be driven positively from the engine-shaft.

The traction-wheels *B* are attached to the axle by clutches *j j'*, Fig. 2, splined on the driving-shaft and held in mesh by springs in order to permit of the wheels rotating independently of each other to facilitate progress over rough roads and the turning of corners. These clutches may also be used for the purpose of disconnecting the engine from the traction-wheels. This is accomplished by connecting the clutches with the rotating plate *m* by means of the rods *i i'*, Fig. 2. The plate *m* is rotated from one of the hand-wheels *I* by the flexible connection *J*. An enlarged view of plate *m* is given in Fig. 5. It contains two spiral slots, into which the ends of the rods *i i'* project, so that when the plate is turned in one direction or the other the rods *i i'* will be drawn inward or thrust outward, thereby operating the traction-wheels. Friction or ball clutches may be used for this purpose.

In order to operate the clutches and the

necessary valves of the engine, I employ flexible connections, as shown in Figs. 1 and 2 and enlarged in the sectional view, Fig. 4. The connections *J* between the hand-wheels *I*, placed conveniently under the control of the engine-driver, and the clutch or clutches and valve consist of tubes arranged one within the other, as many as may be necessary, and supported by suitable bearings on the body of the road-engine. The inner connection may be a rod *n*, as shown in Fig. 4. Provision is made for the vertical oscillation of the body of the carriage with reference to the driving-axle by having each rod or tube composed of two parts capable of sliding on each other, but compelled to rotate together by a spline or pin *k* in the one fitted into a slot in the other. At their lower ends the connections pass into a suitable journal on the gas-engine. Above this journal each connection is provided with a universal joint *p q*, Fig. 4, which admits of the oscillation of the driving-shaft with reference to the body of the carriage, the sections of the universal couplings being long enough to admit of this motion in any direction. Each of the universal couplings is made enough larger than the one it incloses to allow of the rotation of the one without turning the other. The pins or lugs by which the couplings are connected together should fit in slotted holes to permit freedom of motion. Flexible shafts made of spiral wire coils in suitable coverings may be used instead of the universal connections herein described. The valves of the engine are connected with the lower ends of the flexible connections, so as to be operated therefrom in any convenient manner. The air-inlet valve *d'*, Fig. 3, is controlled from the upper hand-wheel *I* by the innermost flexible connection, communicating at its lower end by gears *c'* with an extension-rod splined to the valve-stem. The inlet-supply valves between the tank *U* and the pump *g* are controlled by the flexible connections and the cord *e'*, Fig. 3. The flexible connections are located in the center of the fifth-wheel *F*, so as to allow of the free action of the steering apparatus.

The fifth-wheel *F* is attached to the body of the carriage so as to be capable of turning thereon. In Figs. 1 and 2 it is represented as entirely boxed in by a dust-shield *u*. The fifth-wheel has a worm-gear cut on the periphery thereof, meshing with the worm *S'*, Fig. 2, on a shaft which is attached to the body of the carriage by suitable boxes. The worm is rotated from the steering-wheel *H* by means of the gear *G* and pinion *t*.

The wheels of my improved hydrocarbon road-engine may be provided with any suitable traction device for overcoming the resistance of rough or slippery roads or those of unusual inclination.

Provision is made for backing my improved road-engine by reversing the motion of the driving-wheels by a set of reversing-gears

interposed between the pinion N and the gear M, the said gears being arranged to be brought into or thrown out of action by one of the flexible connections already described. A suitable arrangement of reversing-gears applicable to this purpose is found in the system of gearing used to reverse the motion of the feed-screw in engine-lathes; but I prefer to make the body of my road-engine with a crane-neck, so that the driving-wheel may be turned completely around underneath the driver's seat whenever it becomes necessary to propel the carriage backward.

The central space between the working cylinders and the air-pumps in which the cranks revolve (into which access is had through suitable hand-holes) may be used as a cooling-chamber by the introduction of a small quantity of water within it, either with or without an absorbent material, provision being made for the escape of any vapor by an outlet either directly into the atmosphere or into the exhaust-pipe from the engine.

It will be observed that my improved hydrocarbon-engine can be applied to a large proportion of the carriages in common use. It may also be applied in various other relations with the propelling mechanism different from those herein described or represented without interfering with or preventing the ordinary uses of a carriage-body. It may also be applied to carriages having perch connections between the axles of the two pairs of wheels.

In Fig. 1 I have represented a brake-shoe attached to the rear axle and arranged to be dropped into position between the wheel and the ground. It is operated by means of a chain of the proper length, attached to the body of the carriage and provided with a hand-wheel, spring-pawl, and ratchet.

As it would be decidedly inconvenient to be under the necessity of extinguishing the flame in my improved traction-engine whenever it was required to make a short stop, the clutch Y (or the clutches *j j'*) is interposed between the engine and the driving-wheels, so as to admit of the running of the engine while the carriage remains stationary.

I am aware that steam-carriages for use on common roads have been heretofore constructed on many different plans; but I am not aware that previous to the date of my invention any attempt was made to reduce the weight of a road-locomotive by the production of a compression liquid-hydrocarbon engine capable of locomotion, or that there was described or constructed a compression hydrocarbon-engine of such a design that it was capable of propelling a road-locomotive, more especially when the engine was so designed as to leave the body or platform of the carriage practically unobstructed for the conveyance of passengers or freight, except by the handles or wheels necessary for the guiding or controlling of the vehicle and the regulation of the engine.

I am also aware that it has been heretofore proposed to use liquid fuel in the furnaces of steam road-carriages for the purpose of generating steam for propelling the same—as shown, for instance, in English Patent No. 1,538 of 1863—and such arrangement, which does not remove any of the objections heretofore mentioned, I hereby especially disclaim.

I do not claim herein anything shown or described in the following English patents: No. 8,207 of 1839, No. 6,052 of 1830, No. 2,737 of 1871, No. 6,955 of 1835, and No. 780 of 1865.

I am also aware that it was suggested in English provisional specification No. 10 of 1878, that petroleum or other like motors "might be used to provide motive power" for tram-cars and other self-propelling vehicles.

I claim—

1. The combination with a road-locomotive, provided with suitable running gear including a propelling wheel and steering mechanism, of a liquid hydrocarbon gas-engine of the compression type, comprising one or more power cylinders, a suitable liquid-fuel receptacle, a power shaft connected with and arranged to run faster than the propelling wheel, an intermediate clutch or disconnecting device and a suitable carriage body adapted to the conveyance of persons or goods, substantially as described.

2. The combination with a road-locomotive, provided with suitable running gear including a propelling wheel and steering mechanism, of a liquid hydrocarbon gas-engine of the compression type, comprising one or more power cylinders, a suitable liquid-fuel receptacle, a power shaft connected with and arranged to run faster than the propelling wheel, an intermediate clutch or disconnecting device, and a suitable carriage body located above the engine, substantially as described.

3. The combination with a road-locomotive provided with suitable running gear including a propelling wheel and steering mechanism, of a liquid hydrocarbon gas-engine of the compression type comprising one or more power cylinders, a suitable liquid-fuel receptacle, a power shaft connected with and arranged to run faster than the propelling wheel, an intermediate clutch or disconnecting device, a suitable carriage body located above the engine and a flexible or jointed connection between the engine and the body, substantially as described.

4. The combination with a road-locomotive, provided with suitable steering mechanism, of a hydrocarbon engine applied to the driving axle and having flexible valve or clutch connections located within the steering mechanism, substantially as described.

5. The combination with a road-locomotive provided with a propelling wheel, of a liquid hydrocarbon gas-engine of the compression type, comprising two or more working cylinders and pistons arranged to act in succession

during the rotation of the power shaft, a suitable liquid-fuel receptacle, suitable devices for transmitting motion from the power shaft to the driving axle, and a clutch or disconnecting device, substantially as described.

5 6. The combination with a road-locomotive, provided with a propelling wheel, of a liquid hydrocarbon gas-engine of the compression type, comprising one or more unjackcted

working cylinders communicating with a closed crank chamber, adapted to hold a cooling liquid, and a power-shaft geared to run faster than the propelling wheel, substantially as described.

GEORGE B. SELDEN.

Witnesses:

CHARLES E. RIDER,
HENRY H. SCHLEBER.