

(No Model.)

2 Sheets—Sheet 1.

J. M. BROWNING.
MAGAZINE GUN.

No. 524,702.

Patented Aug. 21, 1894.

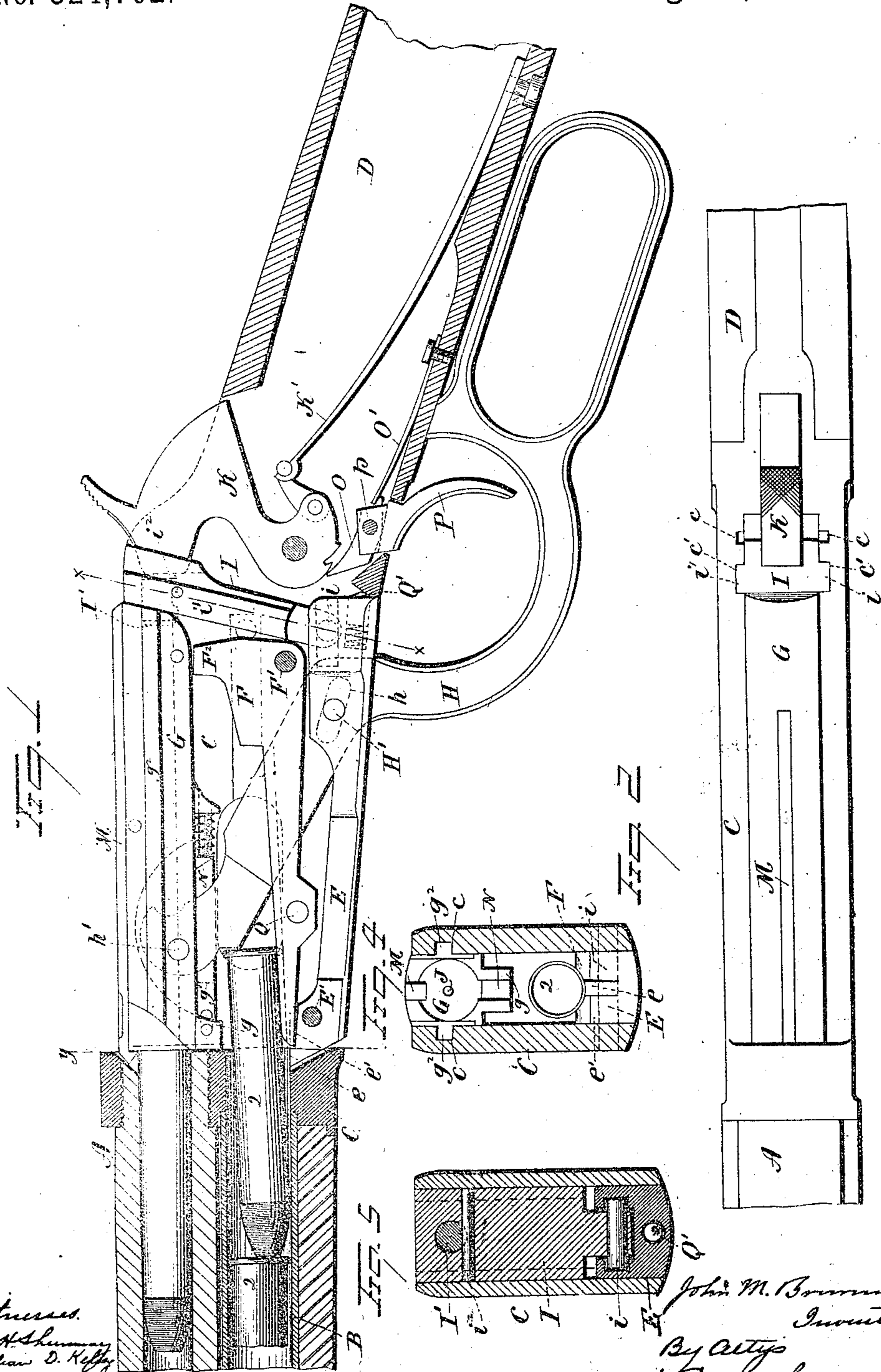

Witnesses.
J. H. Shannon
William D. Kelly

John M. Browning
 Inventor.
 By *Atty*
Earle Seymour

(No Model.)

2 Sheets—Sheet 2.

J. M. BROWNING.
MAGAZINE GUN.

No. 524,702.

Patented Aug. 21, 1894.

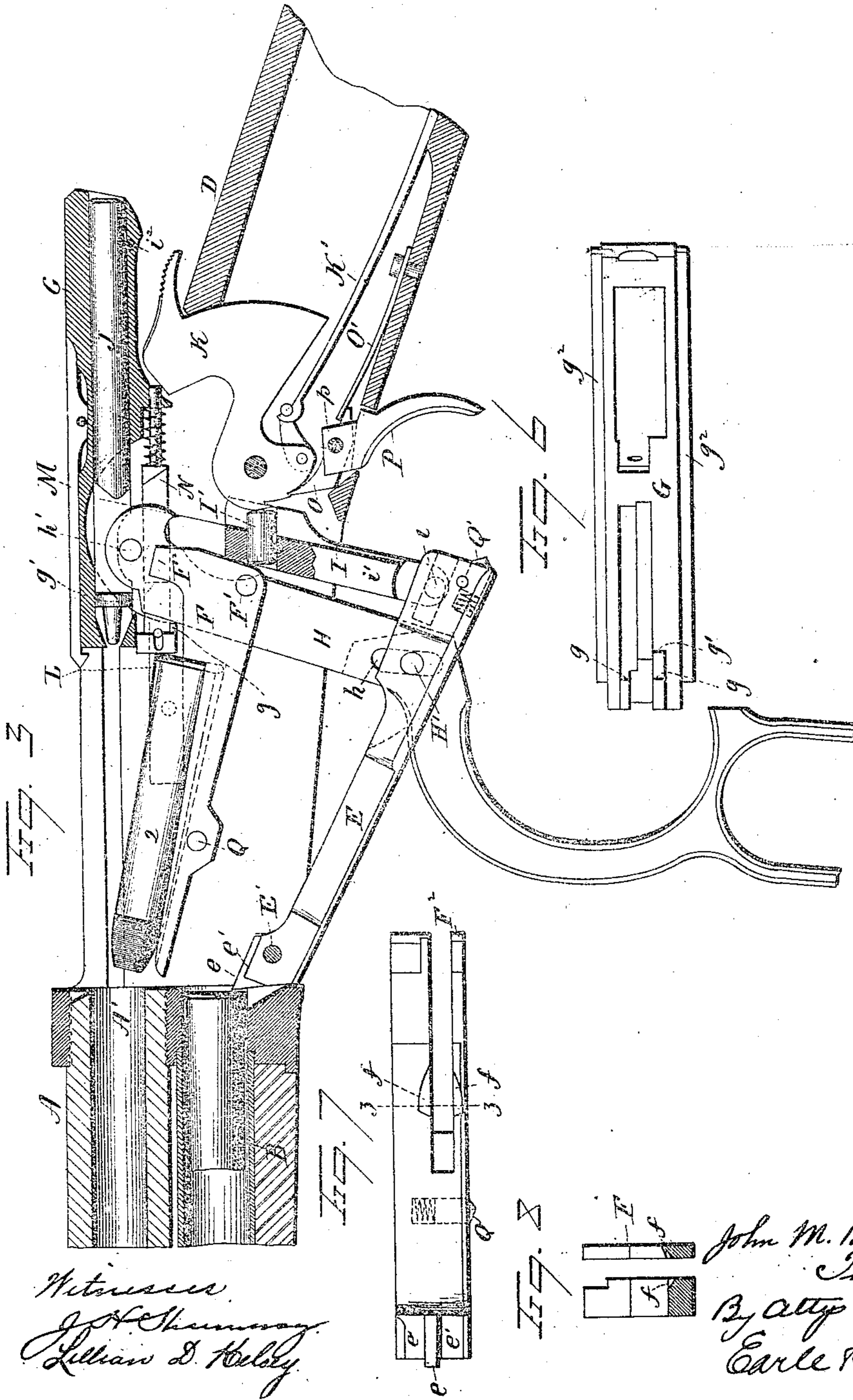

Witnesses
J. H. Shannon
William D. Kelby

John M. Browning
Inventor
By Atty
Earle Seymour

UNITED STATES PATENT OFFICE.

JOHN M. BROWNING, OF OGDEN, UTAH TERRITORY, ASSIGNOR TO THE WINCHESTER REPEATING ARMS COMPANY, OF NEW HAVEN, CONNECTICUT.

MAGAZINE-GUN.

SPECIFICATION forming part of Letters Patent No. 524,702, dated August 21, 1894.

Application filed January 19, 1894. Serial No. 497,416. (No model.)

To all whom it may concern:

Be it known that I, JOHN M. BROWNING, of Ogden, in the county of Weber and Territory of Utah, have invented a new Improvement in Magazine-Firearms; and I do hereby declare the following, when taken in connection with accompanying drawings and the letters and figures of reference marked thereon, to be a full, clear, and exact description of the same, and which said drawings constitute part of this specification, and represent, in—

Figure 1, a broken view partly in section and partly in inside elevation of a magazine fire-arm constructed in accordance with my invention, and shown in its closed position; Fig. 2, a plan view of the arm; Fig. 3, a view corresponding to Fig. 1, but showing the gun in its open position; Fig. 4, a view in transverse section on the line $y-y$ of Fig. 1, looking rearward; Fig. 5, a view in transverse section on the line $x-x$ of Fig. 1, looking forward; Fig. 6, a detached reverse plan view of the sliding breech-block; Fig. 7, a detached plan view of the carrier; Fig. 8, a view thereof in transverse section on the line $z-z$ of the preceding figure.

My invention relates to an improvement in magazine fire-arms, the object being to produce a simple, compact, safe and reliable gun, in which the number of parts and the liability to derangement are reduced, which is constructed with particular reference to avoiding the choking of the gun by the incorrect presentation of a cartridge, or the failure of a cartridge to be properly handled by the breech mechanism, and which is designed to adapt the gun to take a longer cartridge than has heretofore been available for use in a similar gun having a receiver of the same length.

With these ends in view, my invention consists in a magazine fire-arm having certain details of construction, as will be hereinafter described and pointed out in the claims.

My improvements are applied to a gun having a barrel A, magazine B, receiver C, and stock D, all of approved construction, and not needing special description or illustration.

In carrying out my invention, I employ an operating-plate E, hung at its forward or muzzle end on a horizontal pin E', and mov-

ing up and down in a vertical plane on the said pin as a center. The extreme forward end of this plate is constructed with a lug or nose e , which rises, when the rear end of the plate is depressed, into the path taken by the cartridges 2, as they emerge from the magazine into the receiver, whereby the said lug or nose forms a magazine cut-off operating to prevent more than one cartridge from entering the receiver at a time. The said nose or lug rises into the path of the cartridges at the beginning of the opening movement of the gun, and is not retired or moved out of the said path until the gun is again closed. It insures the easy operation of the gun, as it prevents the head of the incoming cartridge from resting upon or impinging against the forward end of the carrier F, and thus causing the same to work with difficulty. It also prevents the choking of the gun where the cartridges differ slightly in length, in which case, but for the said nose or lug, a short cartridge on the carrier might allow the next cartridge in the magazine to secure a partial entrance into the receiver, and by fouling the action of the carrier, choke the gun. By the use of this lug or nose, I secure an effective magazine cut-off without complicating the gun by special independently organized devices for that purpose. The forward end of the operating plate E is also constructed with two lifting faces $e' e'$, corresponding to each other, and respectively located below and on opposite sides of the lug or nose e forming the magazine cut-off. The extreme forward end of the carrier F, rests upon the said lifting faces $e' e'$ when the gun is closed, as shown in Fig. 1 of the drawings, the said end of the carrier being slotted or cut away to clear the magazine cut-off lug e . At the beginning of the opening movement of the gun, the said lifting faces $e' e'$ lift the carrier slightly, and hence the head of the cartridge, whereby the said head is brought into range with a projection g , formed upon the under face of the forward end of the sliding breech-block G, whereby the breech-block is caused to positively engage with the cartridge, and draw the same back into the receiver upon the carrier F, which is constructed as shown by Figs. 7 and 8 of the drawings, with a depression or pocket

f, located below the level of its floor, and provided to let the head of the cartridge drop down, after the cartridge has been fully drawn into the receiver and cleared from the magazine, and disengage from the projection *g* so as to permit the sliding breech-block to complete its rearward movement. I thus provide for positively locating each cartridge in right position upon the carrier by means of the breech-block, so that no matter how rapidly the gun may be fired, it cannot choke, by reason of the carrier being elevated to present the cartridge to the gun-barrel A before the cartridge is in right position upon it. I conceive it to be necessary to thus provide for insuring the right location of the cartridges upon the carrier by means of the breech-block, in a gun wherein the cartridge is not, when the first opening motion of the gun begins, located entirely on the carrier.

With the rear end of the operating plate E, I pivotally connect the finger or operating lever H, by means of a pin *H'*, which extends into an elongated slot *h* formed in the lever, the upper end of which is connected by a pin *h'* with the forward end of the sliding breech-block G, which is moved back and forth by the action of the said lever. This finger-lever has the incidental function of guarding the trigger, and is sometimes called the trigger-guard, but I have chosen to describe it in connection with its larger function. The said lever is also called the operating-lever. I also connect with the rear end of the operating plate E and at a point in rear of the connection therewith of the finger-lever H, a locking-block I, the lower end of which is pivotally connected with the rear end of the plate by means of a pin *i*. This locking block moves up and down in the receiver at an angle slightly inclined rearward from the vertical, being constructed upon its opposite edges with guides *i' i'*, which take into corresponding grooves *cc* formed in the opposite walls of the receiver, as shown in Fig. 2. In its elevated position the upper end of this locking-block stands directly back of the rear end of the breech-block, the same being then in its closed position. On the other hand when the sliding-block is depressed by the opening of the gun, its upper end retires below the path of the breech-block, as shown in Fig. 3, and permits the rearward or opening movement thereof. The upper end of this locking block is furnished with a short striking-piece *I'*, limited in endwise movement by means of a pin *i''*, as clearly shown in Fig. 1 of the drawings. This striking-piece is arranged so that when the block is in its elevated or closed position, it transmits the blow or impact of the hammer K upon its rear end to the firing-pin J, which engages with its forward end.

A locking-block constructed and arranged as described, provides simple and effective means for locking the breech-block in its closed position, and by reason of its location,

enables a longer cartridge to be used than has heretofore been possible in a gun constructed with a receiver of the same length.

The carrier F is pivotally hung upon a horizontal pin *F'* mounted in the receiver and passing through its rear end, and is swung or lifted into its elevated position, in which it is shown by Fig. 3 of the drawings, by the engagement of a shoulder *g'* depending from the lower face of the sliding breech-block, with an upwardly projecting operating lug *F''*, formed at the rear end of the carrier. The upward motion of the carrier is checked by two corresponding guides L, of which one is shown in Fig. 3 of the drawings, these guides being set into grooves provided for them in the opposite walls of the receiver, and being located so that they arrest the upward movement of the carrier when it has brought the cartridge carried by it into right presentation in front of the chamber A' in the gun-barrel A. The sliding breech-block G, is furnished with an extractor M set into its upper face, and with an ejector N depending from its lower face, the said extractor and ejector being of ordinary construction and operation. The breech-block itself is constructed with two corresponding longitudinal ribs *g² g²*, (Fig. 4) which enter suitable grooves *c' c'* formed to receive them in the opposite walls of the receiver in the ordinary manner. The hammer K is furnished with a hammer-spring *K'*, and co-operates with a sear O having a sear-spring and trigger *O'*. A trigger P mounted on the same center *p* with the sear O, operates the same to release the hammer. As herein shown, the operating-link E and the carrier F, are furnished with friction pins *Q, Q'* of ordinary construction and operation, but these may be dispensed with, or otherwise located as desired.

Having now described in detail the construction of my improved gun, I will proceed to briefly set forth the mode of its operation. Assuming that the gun is closed, as shown in Fig. 1 of the drawings, and that the magazine-spring has partly introduced the cartridge 2 into the receiver and upon the carrier, we will suppose that the finger or operating lever is thrown down and forward; this will operate to depress the rear end of the operating-plate E, and therefore to draw down the locking-block I, so as to permit the sliding breech-block to be moved rearward. At the same time the rear end of the plate E, is being depressed, its forward end and hence the nose *e* and the lifting-faces *e' e'* are being elevated, the latter then operating to slightly lift the forward end of the carrier, and hence the cartridge; and the former rising into the path of the cartridge so as to be in position to act as a magazine cut-off the instant the cartridge has passed entirely into the receiver. The lifting of the forward end of the carrier and hence the cartridge by the lifting faces *e' e'*, brings the cartridge into position to be positively engaged by the projection *g* of the breech-block G, and positively drawn into the receiver in

case the magazine-spring does not act quickly enough or powerfully enough to push the cartridge unaided into the receiver; then just before the finger-lever reaches its extreme forward position, as shown in Fig. 3, the shoulder or projection g' of the breech-block engages with the operating lug F^2 of the carrier, and swings the same on its pivot so as to cause its forward end to be lifted, and present the point of the cartridge in right position before the cartridge chamber A' , to be forced thereinto by the breech-block as the same moves forward, which it will immediately begin to do when the closing movement of the finger-lever is begun. Then after the breech-block has moved forward into its closed position and the cartridge has been introduced into place in the cartridge-chamber A' , the locking-block moves into place back of the breech-block, and the operating-plate assumes its closed position, in which its nose e is depressed below the path of the cartridges, and in which its lifting faces $e' e'$ permit the forward end of the carrier to take its lowest position.

It will be seen from the foregoing that my improved gun is composed of comparatively few parts, compactly arranged, and is not liable to derangement, and that it may be operated with great rapidity without danger of choking.

It is obvious that in carrying out my invention some changes from the construction herein shown and described may be made, and I would have it understood that I do not limit myself to such construction, but hold myself at liberty to make such changes and alterations therein as fairly fall within the spirit and scope of my invention.

Having fully described my invention, what I claim as new, and desire to secure by Letters Patent, is—

1. In a magazine fire-arm, the combination with the barrel, magazine and receiver thereof, of an operating-plate pivotally hung at its forward end, a downwardly movable finger or operating lever and an upwardly movable locking-block connected with the rear end of the said plate, and a sliding breech-block connected with the upper end of the finger or operating lever and actuated thereby, substantially as set forth.

2. In a magazine fire-arm, the combination with the barrel, magazine and receiver thereof, of an operating plate pivotally hung at its forward end, a downwardly movable finger or operating lever pivotally connected with the rear end of the operating-plate and forming a guard for the trigger, an upwardly movable locking-block pivotally connected with the rear end of the said plate at a point in rear of the pivotal connection of the said finger or operating lever, and arranged to move up and down in the receiver, and a sliding breech-block connected with the upper end of the finger-lever and actuated thereby, substantially as set forth.

3. In a magazine fire-arm, the combination with the barrel, magazine and receiver thereof, of a plate pivotally hung at its forward end and constructed thereat with a nose or lug forming a magazine cut-off, and rising into the path in which the cartridges emerge from the magazine when the rear end of the plate is depressed, a sliding breech-block, and a finger or operating lever pivotally connected with the rear end of the said plate, and connected at its upper end with the breech-block which it actuates, and forming a guard for the trigger substantially as described.

4. In a magazine fire-arm, the combination with the magazine and carrier thereof, of a plate hung at its forward end and constructed thereat with two lifting faces upon which the forward end of the carrier rests when the same is in its lowest position, and whereby the carrier and the cartridge upon it are slightly lifted when the rear end of the plate is depressed, substantially as set forth.

5. In a magazine fire-arm, the combination with the barrel, magazine and receiver thereof, of an operating-plate pivotally hung at its forward end and constructed thereat with a nose or lug forming a magazine cut-off, and with a lifting face, a carrier located within the receiver, and resting at its forward end when in its lowest position upon the said lifting face, a sliding breech-block, a finger or operating lever pivotally connected with the rear end of the operating plate, connected at its upper end with the breech-block which it actuates, and forming a guard for the trigger and means for locking the breech-block in its closed position, substantially as described.

6. In a magazine fire-arm, the combination with a sliding breech-block and an operating-plate pivotally hung at its forward end, of a carrier resting at its forward end, when in its lowest position, upon the said plate which lifts the said end of the carrier when the plate is operated in the opening movement of the gun, the said breech-block being constructed upon its lower face to engage the head of the cartridge when the carrier is lifted, as described, and the said carrier being constructed to permit the cartridge to drop away from the breech-block after the cartridge has been fully entered into the receiver of the arm, substantially as set forth.

7. In a magazine fire-arm, the combination with the barrel, magazine and receiver thereof, of a plate pivotally hung at its forward end, a downwardly movable finger or operating lever pivotally connected with the rear end of the plate and operating the same, and forming a guard for the trigger, an upwardly movable locking-block connected with the rear end of the said plate, a sliding breech-block connected with the upper end of the finger or operating lever, and actuated thereby, and a carrier located within the receiver and arranged to have an initial lifting move-

ment imparted to it by the plate, substantially as described.

8. In a magazine fire-arm, the combination with the barrel, magazine and receiver thereof, of a plate pivotally hung at its forward end, a finger or operating lever pivotally connected with the rear end of the plate, forming a guard for the trigger, a sliding breech-block connected with the upper end of the finger or operating lever and actuated thereby, a carrier located within the receiver, and a locking block connected with the rear end of the operating plate, arranged to play up

and down in the receiver and provided with a striking piece which, in the closed position of the breech-block, is aligned with the firing-pin carried thereby, substantially as described. 15

In testimony whereof I have signed this specification in the presence of two subscribing witnesses. 20

JOHN M. BROWNING.

Witnesses:

FRED C. EARLE,
GEO. D. SEYMOUR.