

(No Model.)

3 Sheets—Sheet 1.

A. BURGESS. FOLDING GUN.

No. 521,202.

Patented June 12, 1894.

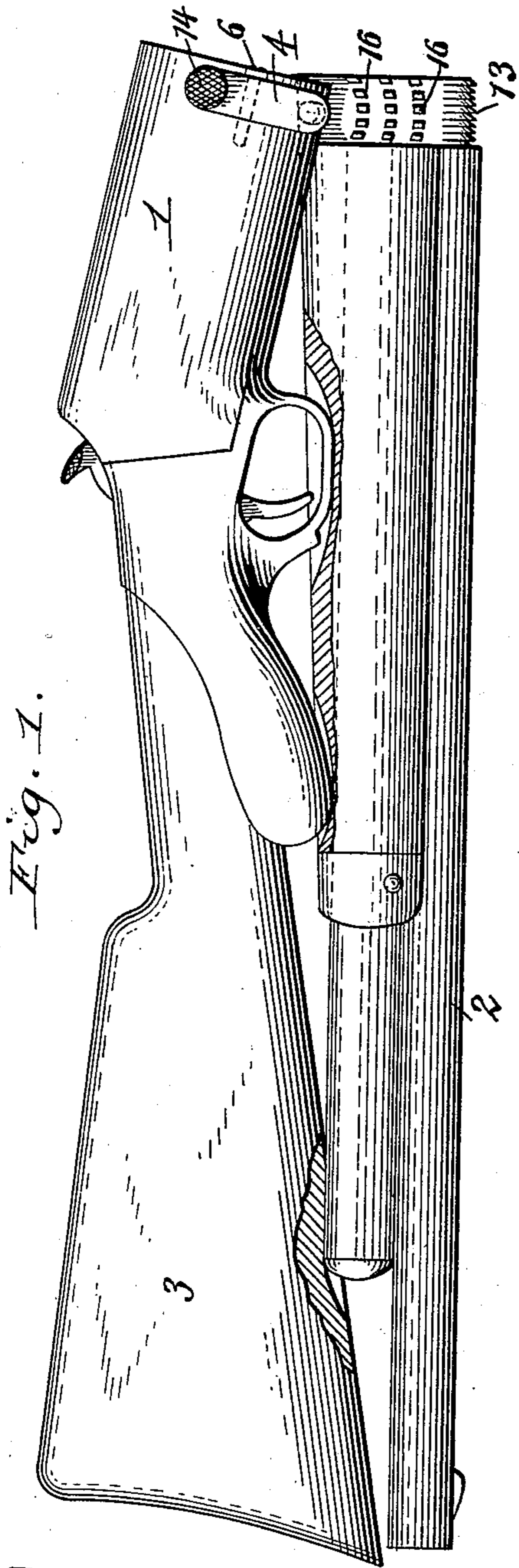

Fig. 5.

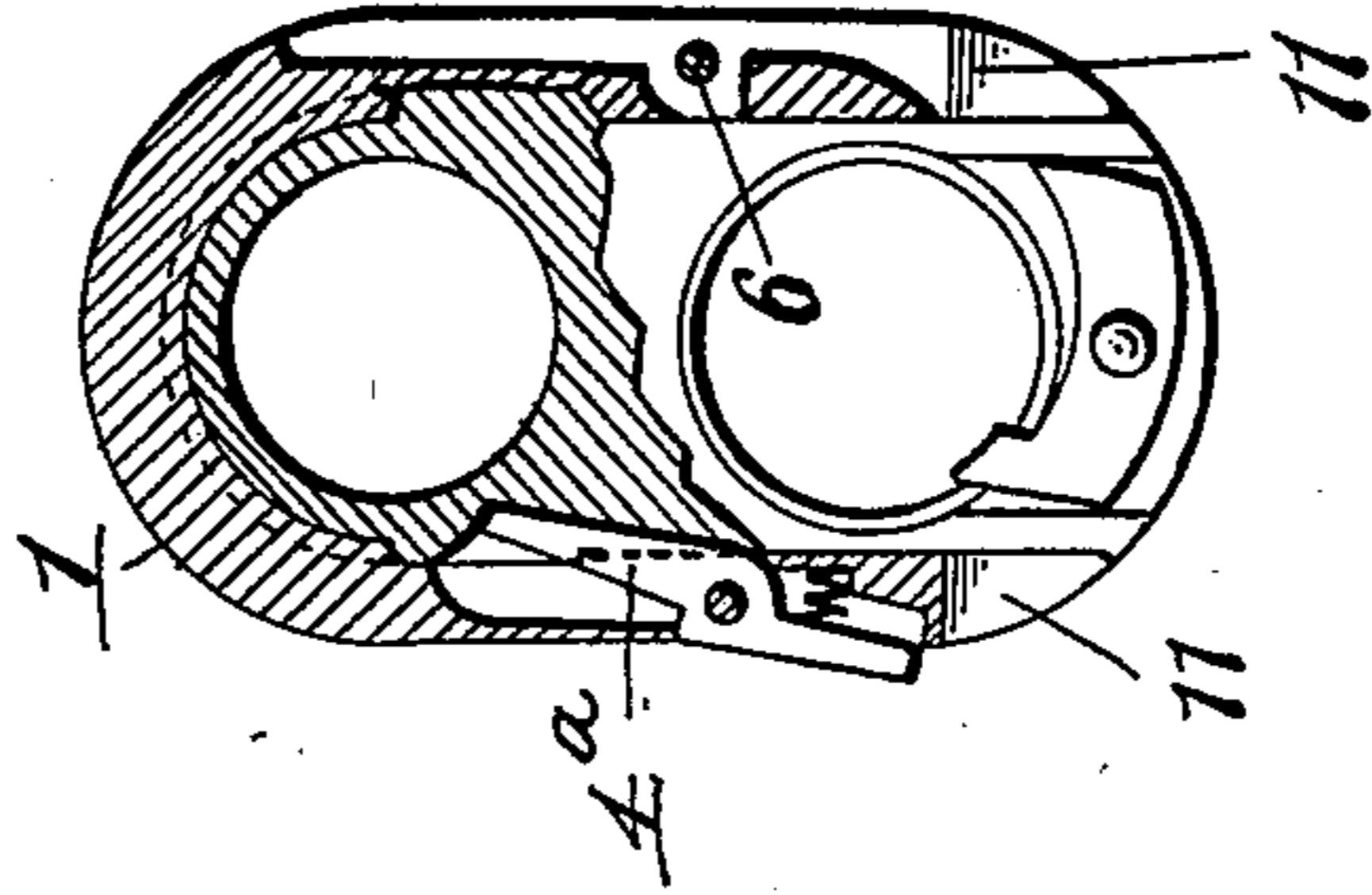

Fig. 4.

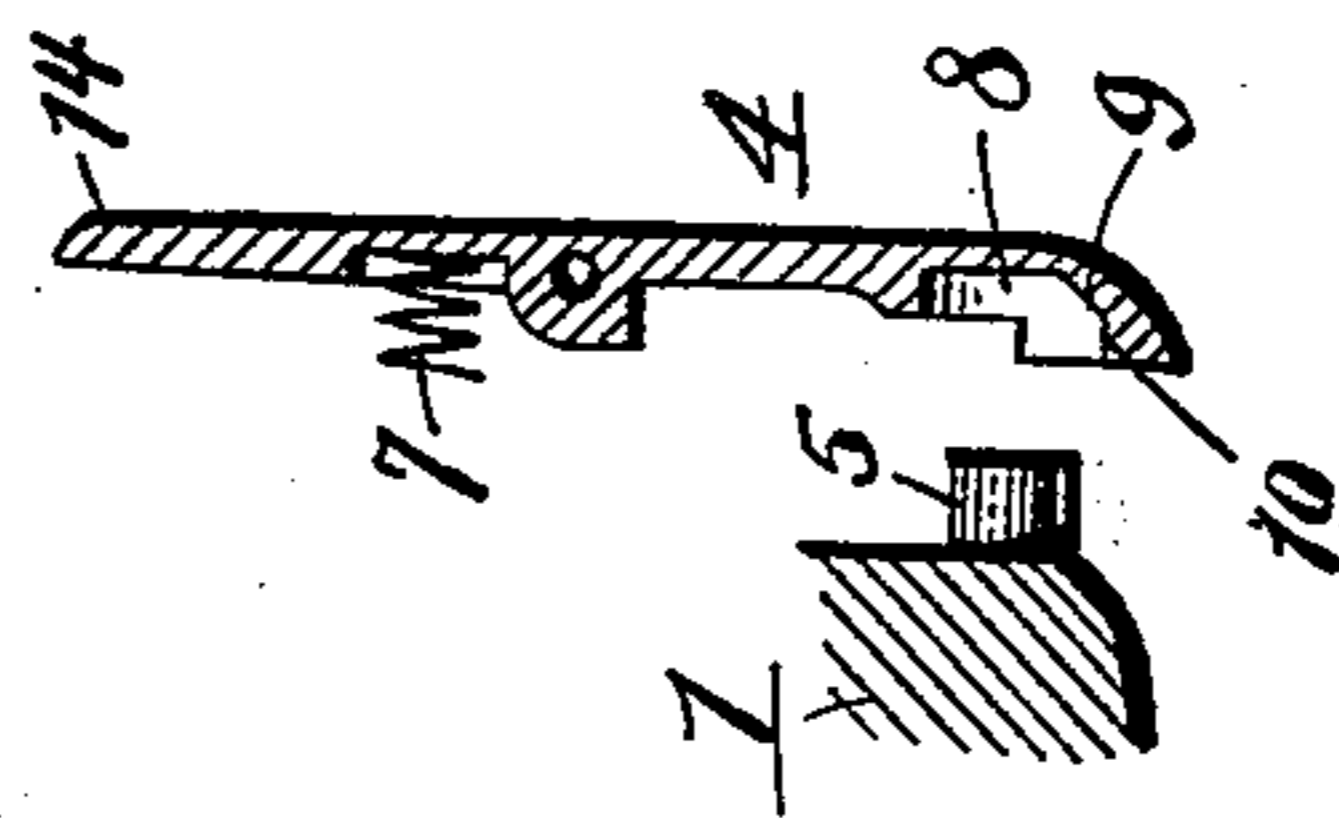

Fig. 3.

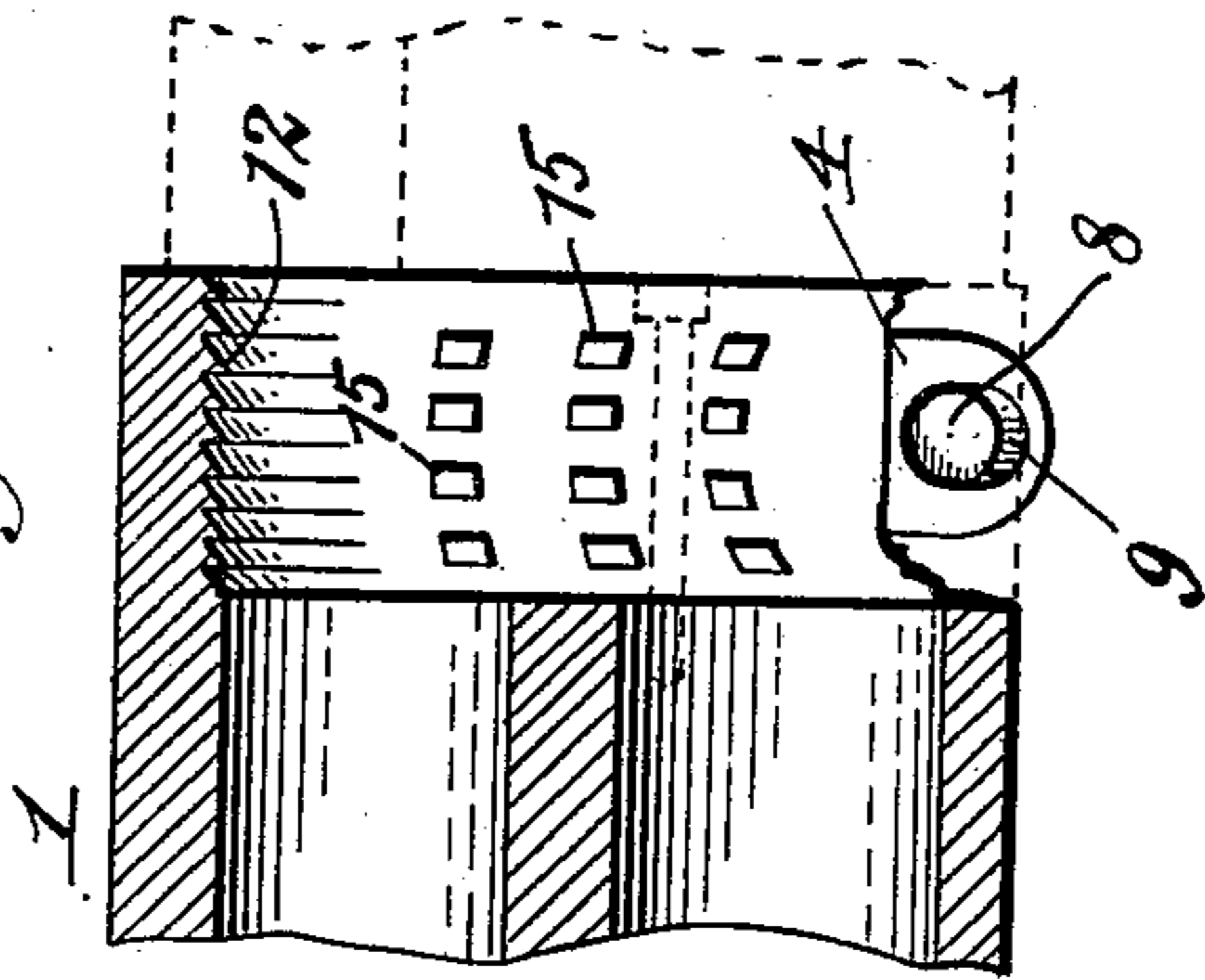
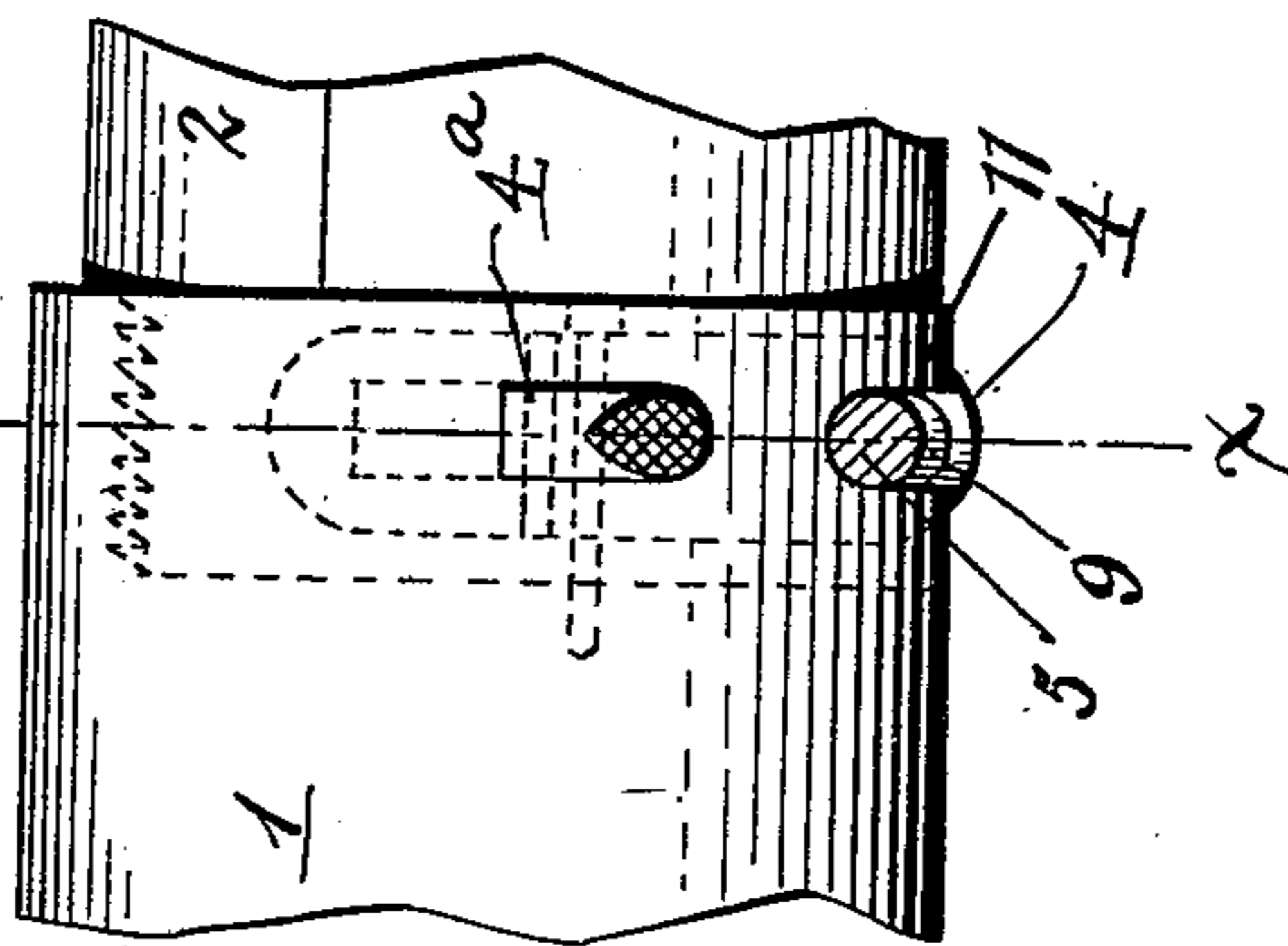

Fig. 2.



Witnesses:
Theo. L. Popp.
Jno. Nevill

Inventor:
Andrew Burgess

(No Model.)

3 Sheets—Sheet 2.

A. BURGESS.
FOLDING GUN.

No. 521,202.

Patented June 12, 1894.

Fig. 6.

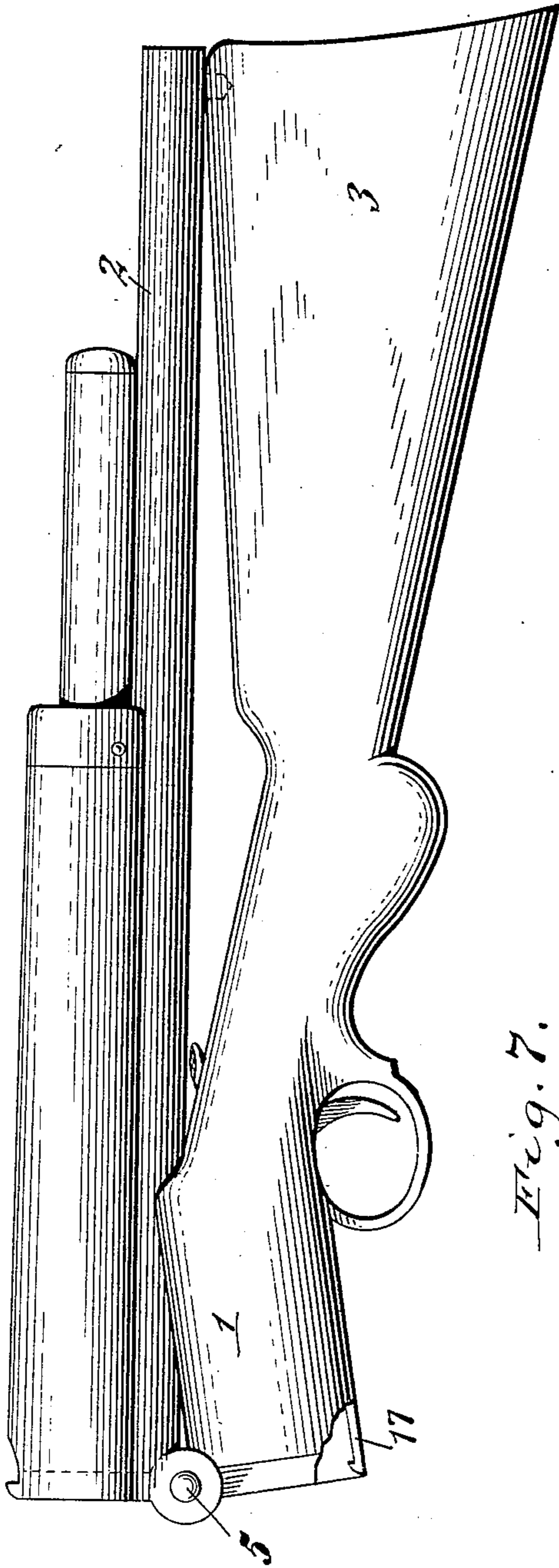
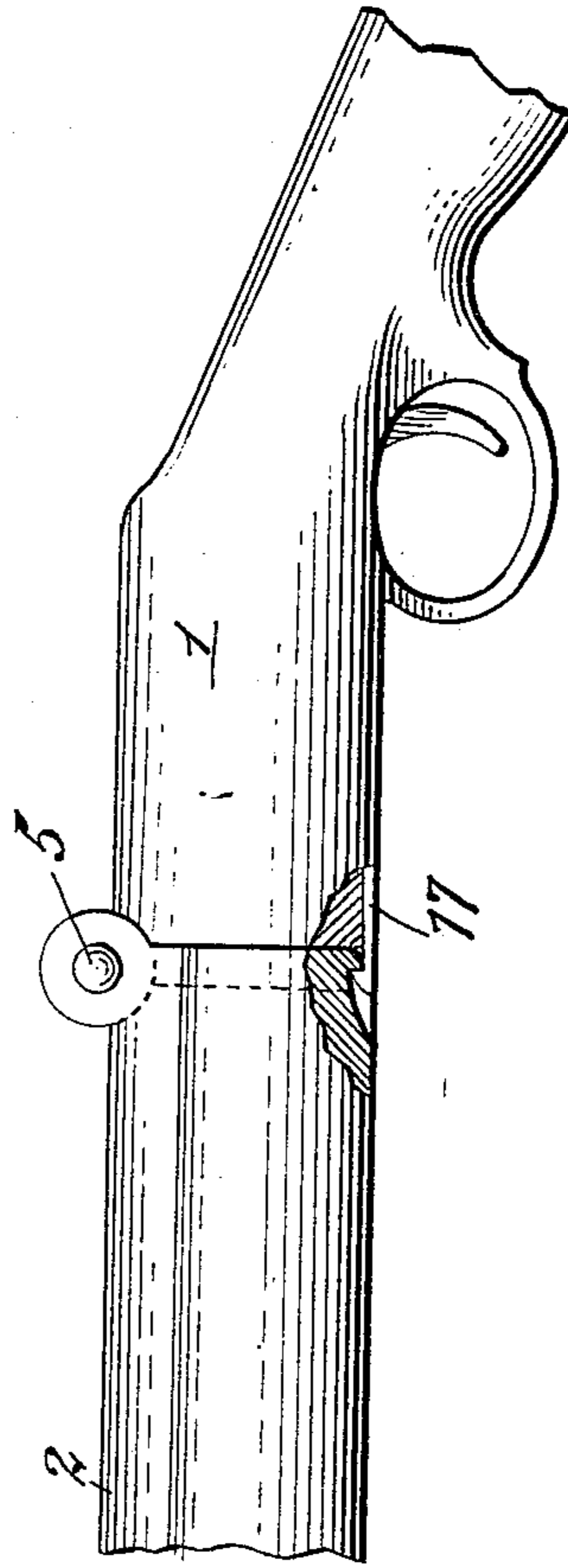

Fig. 7.



Witnesses:

Theo. L. Opp.
Jno. Herin

Inventor.

Andrew Burgess

(No Model.)

3 Sheets—Sheet 3.

A. BURGESS.
FOLDING GUN.

No. 521,202.

Patented June 12, 1894.

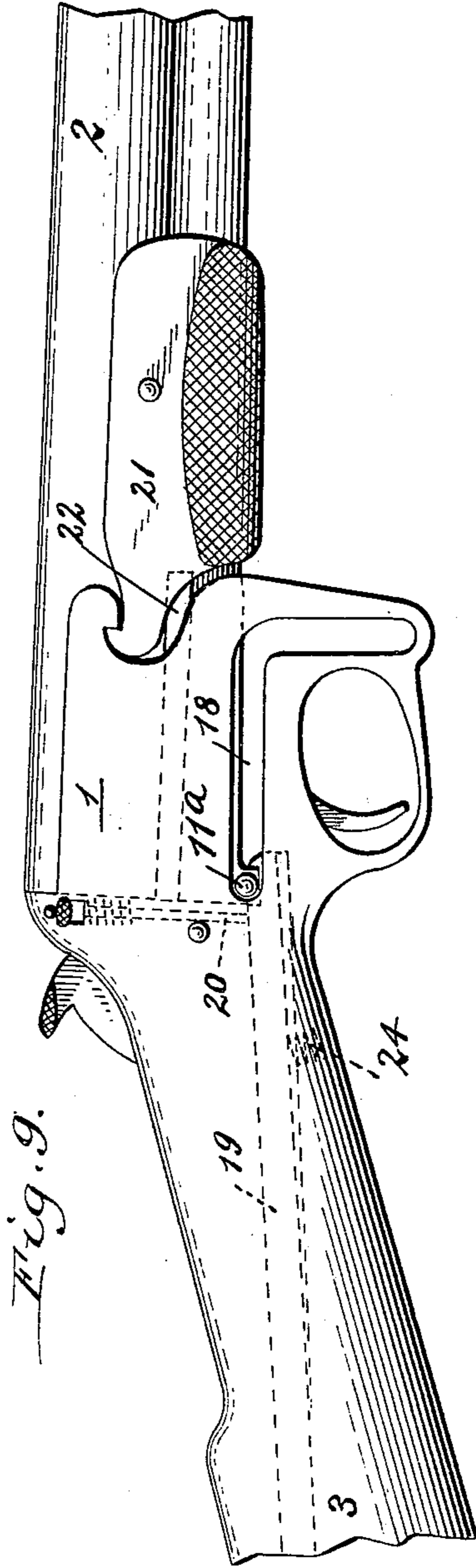
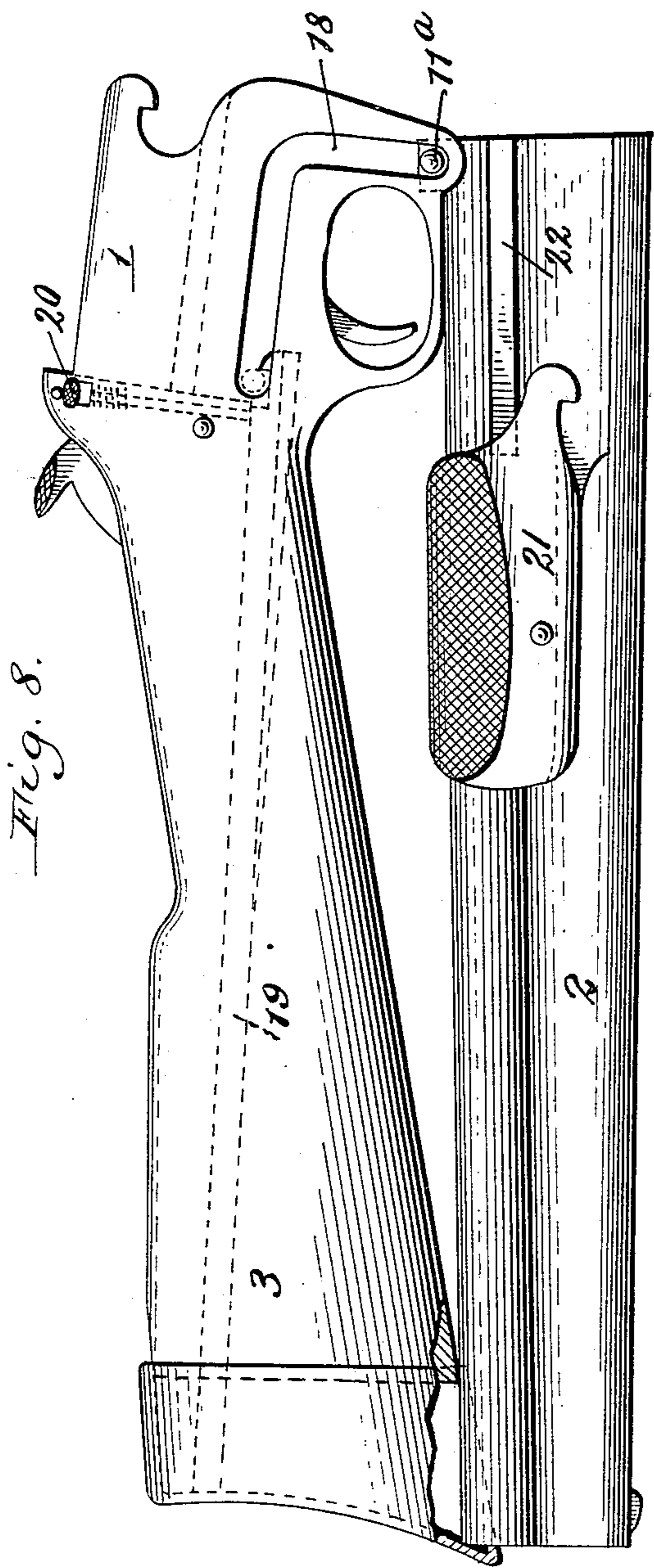

Witnesses:
 Theo. L. Popp.
 Jas. Keeni

Inventor:
 Andrew Burgess

UNITED STATES PATENT OFFICE.

ANDREW BURGESS, OF BUFFALO, NEW YORK.

FOLDING GUN.

SPECIFICATION forming part of Letters Patent No. 521,202, dated June 12, 1894.

Application filed January 26, 1893. Serial No. 459,775. (No model.)

To all whom it may concern:

Be it known that I, ANDREW BURGESS, a citizen of the United States, residing at Buffalo, in the county of Erie and State of New York, have invented new and useful Improvements in Folding Guns, of which the following is a specification.

My invention relates to guns for police and other purposes, and consists in means and methods of folding, with the object of obtaining compactness for easy carrying and preserve its availability for immediate use.

The object of the invention stated more fully is to produce a gun, (not a pistol) which will fold into very compact shape, and when folded will enter a holster or case not much larger than the common case for a policeman's club, the gun being capable of quick extension, and when extended being a strong and efficient weapon, and if a magazine gun being ready for a number of shots immediately on extension.

In the accompanying drawings Figure 1 is an outside view of the gun folded. Fig. 2 is a similar view of the joint in closed or firing position with the left hand barrel trunnion cut off to show it in place. Fig. 3 shows the inside of frame at joint. Fig. 4 is a detached longitudinal section of one of the barrel catches, showing a trunnion detached. Fig. 5 is a cross section of the frame, on line $x-x$ of Fig. 2 looking forward to show the trunnion slots—the rear; and opening into the magazine and the cartridge stop. Fig. 6 is an outside view of a modification of this gun, folded. Fig. 7 shows same modification as Fig. 6, but closed, or firing position. Fig. 8 is a modification of folding device adapted to a sliding barrel. Fig. 9 is a closed view of the arm, as shown in Fig. 8.

In the drawings, 1 is the frame—2 the barrel, and 3 the butt stock of any gun.

In Fig. 1 I show this invention applied to a magazine gun having a frame constructed with an opening at its front and bottom. A spring actuated piece 4, is arranged at one or both sides of the frame to engage a trunnion 5 fixed to the barrel portion of the gun and thereby forms a hinge to connect the frame and barrel together. The frame part of hinge 4, may be fixed to the frame as a simple spring, but I prefer to construct it as a vertical spring

lever, and attach it to the frame by a pivot as 6, and arrange a spring as 7 to turn its lower holding end inward. A depression 8 is made in the inner side of hinge lever 4 and has an incline 9 downward to terminate against the shoulder 10. The barrel part of the hinge consists of a projection or trunnion, 5, at the side of the bottom of the barrel, or magazine. A vertical open slot 11, in the bottom of the front of the frame receives the barrel trunnion and supports it in all but the downward direction, and for support in that direction the lever 4 is arranged so the trunnion may be entered into its pocket 8, as shown in Fig. 2 with trunnion inserted, and cut off to indicate its position.

As shown in Fig. 2 the rear end of the barrel is entered into the housing or opening in the front part of the frame, and the bottom of the barrel part of the gun is held firmly in its place in the frame of the stock part of the gun, the trunnions holding it up by their engagement in pockets 8.

To support the top part of the barrel the inside front part of the frame is provided with V-threads or grooves 12 having their rear shoulders vertical as in Fig. 3 and the top of barrel as in Fig. 1 has corresponding threads 13 with their forward shoulders vertical.

When, as shown in dotted lines in Fig. 2, the barrel is in the frame in firing position, and the threads 12 and 13 interlocked, said threads support the barrel in all but a downward direction, and lever, or levers 4 hold it upward as described.

To fold the gun from the position of its parts shown in Fig. 2 to that shown in Fig. 1, a pressure on the thumb piece 14 of lever 4, will compress its spring 7 and turn out its lower end to release the barrel trunnion from the pocket 8 when said trunnion rides down the incline 9 (or may be forced down by striking the barrel down by a blow of the hand) until it strikes the shoulder 10 which stops its descent, as the movement of the lever is so limited that it can only turn out the depth of the incline 9. When stopped by the shoulder 10 of the lever 4 the barrel has reached so low a position that its threads 13, have fallen below and become released from the threads 12 of the frame, and the barrel is

then free to turn downward so that it may be folded up against the stock, as in Fig. 1, in form and compactness suitable to carry in a holster and belt. To change the gun from position of Fig. 1 to firing position, we have only to grasp the stock portion, at the small of stock, and give it a quick movement, when the inertia of the barrel portion causes the parts to turn on the hinge until the rear of the barrel enters the opening in the front of the frame, and striking the beveled threads 12 they depress it to ride under them until it reaches home, when the spring lever 4 bearing up by its bevel on the incline 9 on the trunnions, then raise the end of the barrel and interlock the grooves 12 and 13, and the force of the spring lever still acting on the incline, or in the pocket 8 will hold the parts in position. If desirable to hold up the barrel more firmly, the additional catch 4^a is also pivoted in the frame to form cam engagement in the side of the barrel as shown in Fig. 5. For greater strength, projections or sectional screw threads 15 may be formed inside the frame and corresponding threads 16 on the barrel to enter in the spaces and spring up to engage the parts 15 and interlock with the threads 16 in the same manner as the threads 12 and 13 at the top. The threads 12 and 13 in conjunction with the projections 15 and 16, or not, with a joint of but limited movement will suffice to open the breech, as in ordinary breech loading guns, and may be used for that purpose only, or still further to fold such guns.

It is obvious that a frame closed at the bottom and open at the top, and a joint arranged at the top would be an equivalent construction.

I do not limit my claims to any particular joint or system of fire arm, and show several modifications and combinations to more broadly illustrate and cover the invention.

In Fig. 6 the joint is formed at the top of the barrel and frame, and the barrel turns up and back over the top of the stock part, to fold the gun. This joint turns to close, to the position shown in Fig. 7, when the spring snap 17 holds it in closed or firing position. It will be seen, the top of the frame is hollowed out to allow the muzzle of the barrel to close down against the butt of the gun when in folded position. Figs. 10 and 11 show a similar joint but with the hinge at the bottom of the gun, and the stock jointed to the rear of the frame in the same manner as the frame is jointed to the stock in Fig. 6.

Figs. 8 and 9 show a joint modified to operate in a gun in which the barrel is arranged to reciprocate in the frame as in my application of January 16, 1893, and consists of the trunnions 11^a on the barrel as in Fig. 1 entering the angular slots, or grooves 18 in the frame. Fig. 9 shows an arm having this modification in a closed, or firing position. The rod 19 that connects the barrel part to the stock part of the gun, can be engaged by the

spring push pin 20, to press said rod down as to the dotted lines shown, to unhook the rod from the barrel part. Then the barrel may be unlocked from the frame by turning down the rear part, or pressing forward on, the handle 31. By continuing the handle forward it will move the barrel which is guided forward by ribs 22, and as the rod 19 having been unhooked no longer stops it, it may be moved until the ribs 22 leave their grooves in the frame and the trunnion 11^a reaches the down angle of the slot 18, and dropping down to the lower termination of said slot the barrel is free to turn on its trunnion until it reaches the position shown in Fig. 8, with the muzzle against the rear part of the stock.

To close the gun to firing position the barrel is turned down and forward, and as it straightens with the trunnion rises in the slot to its angle, and until the ribs 22 reach their grooves, when the barrel may be moved back to position as shown in Fig. 9, and the beveled forward end of rod 19 having been first depressed will be snapped into its engaging position as there shown by the spring 24 and the handle turned to lock the barrel back in the frame.

It will be seen in Figs. 1, 6 and 8 that I cut into the stock or frame to allow the closer folding together of the gun, and thereby get a bearing to support the parts from "shucking" on each other or giving too great lateral strain on the joints.

The threads shown in Figs. 1 and 2 at the top of the barrel and frame, may be modified in number from simple hooks on a part, or be on one part, or both, square or V-shape, or they may be supplemented as shown by the sections of threads, which may also be used in lieu of the others.

I prefer trunnions to form the hinge on both sides of the barrel, but one alone may be used, and the trunnions may be arranged on the frame by a mere reversal of parts.

I do not herein claim a construction of the gun by which the magazine stop is actuated to begin feeding cartridges by the extension of the gun, nor do I claim certain other modifications and improvements more particularly set forth in my application, Serial No. 510,509, filed May 8, 1894.

I claim—

1. In a gun, a barrel portion and a stock portion, a hinge joint between to allow rotation as described in combination, and with a spring to shift the joint and raise the barrel, in closing, into engagement with a locking device, substantially as described.

2. In a gun a forward or barrel portion, and a rear or stock part, hinged together by a yielding joint, teeth and grooves in the barrel and stock portion, and means to flex and shift the joint to interlock the teeth, all in combination, substantially as specified.

3. In combination in a gun, a frame open at the front and bottom, and closed and threaded at the top, a barrel with corresponding threads

at its top, a joint at the bottom of barrel and frame so arranged, to allow the joint to shift and the barrel to fall and unlock the threads, and flex the joint to open the breech.

5 4. In combination in a gun a frame open at the front and bottom, and closed and threaded at the top, a barrel with corresponding threads at its top, a joint at the bottom of barrel and frame, so arranged, to allow the joint to shift
10 and the barrel to fall and unlock the threads, and flex the joint to open the breech and fold the gun, and a cam catch to hold the barrel up in the frame when in firing position, substantially as specified.

15 5. In a gun a frame open at the front and closed and threaded at the top, substantially as described, in combination with a barrel having corresponding threads or grooves, at its top, and a flexible joint to connect the
20 frame and barrel, and a spring to shift the parts vertically at the joint, to interlock their threaded portions.

6. In a gun a frame open at its front and having a closed top, and having one or more ribs and grooves in combination with a barrel provided with corresponding ribs and grooves at its top, to interlock with those of the frame, and beveled surfaces on one or both of said sets of ribs, to allow them to ride into locking position as described, and a spring shifting joint to snap the barrel ribs into the
30 grooves of the frame.

7. In a gun, a frame open at its front, and provided with inside projections and spaces
35 between, in combination with a barrel whose rear end at its sides has depressions or spaces to correspond with the projections of the frame, and projections on said barrel to enter the spaces in the frame, and a shifting joint
40 to allow movement of the projections of the barrel and frame, relatively to each other, and interlock them and hold the barrel in the frame, substantially as specified.

8. In a folding gun a frame open at its front
45 and bottom, open vertical slots in the sides of the bottom of the frame, in combination with a barrel provided with trunnions at its rear substantially as described, to enter said slots of the frame and turn therein to open the
50 breech and fold the gun, and a catch at the top of the frame to hold the gun in firing position.

9. In a folding gun, a frame and a barrel having longitudinal movement in the frame,
55 trunnions on said barrel, slots in the frame to receive said trunnions and guide them

downward to allow the barrel to fold beneath the stock, all in combination substantially as described.

10. In a folding gun, a frame having a
60 guideway, a barrel guided to reciprocating movement, in the frame, a stop to limit such movement, and means to lock said barrel to the frame, in firing position; in combination with trunnions on the barrel, and which enter
65 grooves in the frame, to hinge the barrel to the frame, so that said barrel may turn on a vertical plane downward, when in its forward position, substantially as specified.

11. In a magazine gun, the barrel, front
70 stock, and magazine connected together, the magazine being under the barrel and provided with a cartridge stop at its mouth, combined with a rear stock hinged to said front stock
75 so as to fold against or extend into line with the barrel, the joint and the feeding end of the magazine being covered by a housing when the gun is in extended or firing position, substantially as described.

12. In a folding gun, the stock and barrel
80 hinged together by a yielding or slip joint, the housing covering the joint, said housing having projections interlocking with projections on the folding part when the gun is in extended position, all combined substantially
85 as described.

13. In a folding gun, the barrel portion and the stock portion, and a slip jointed hinge connecting the two, whereby the gun may be held rigid in extended position, or folded
90 with the barrel in close proximity to the stock throughout its length, the parts in combination substantially as described.

14. A folding gun having a joint at the junction of the front of the stock or frame
95 and rear of the barrel, so that the barrel and stock may fold into contact substantially throughout their length, the barrel and stock being of substantially the same length, a housing on one of the folding parts overlapping
100 some portion of the other part to strengthen the joint when the gun is in extended position, and a retaining catch to hold the parts in such position, all combined substantially as described.
105

In testimony whereof I herewith affix my signature in presence of two witnesses.

ANDREW BURGESS.

Witnesses:

THEO. L. POPP,
JNO. NEVIN.