

(No Model.)

J. WILLS.

MACHINE FOR POINTING AND PUNCHING SHOE LACES.

No. 494,311.

Patented Mar. 28, 1893.

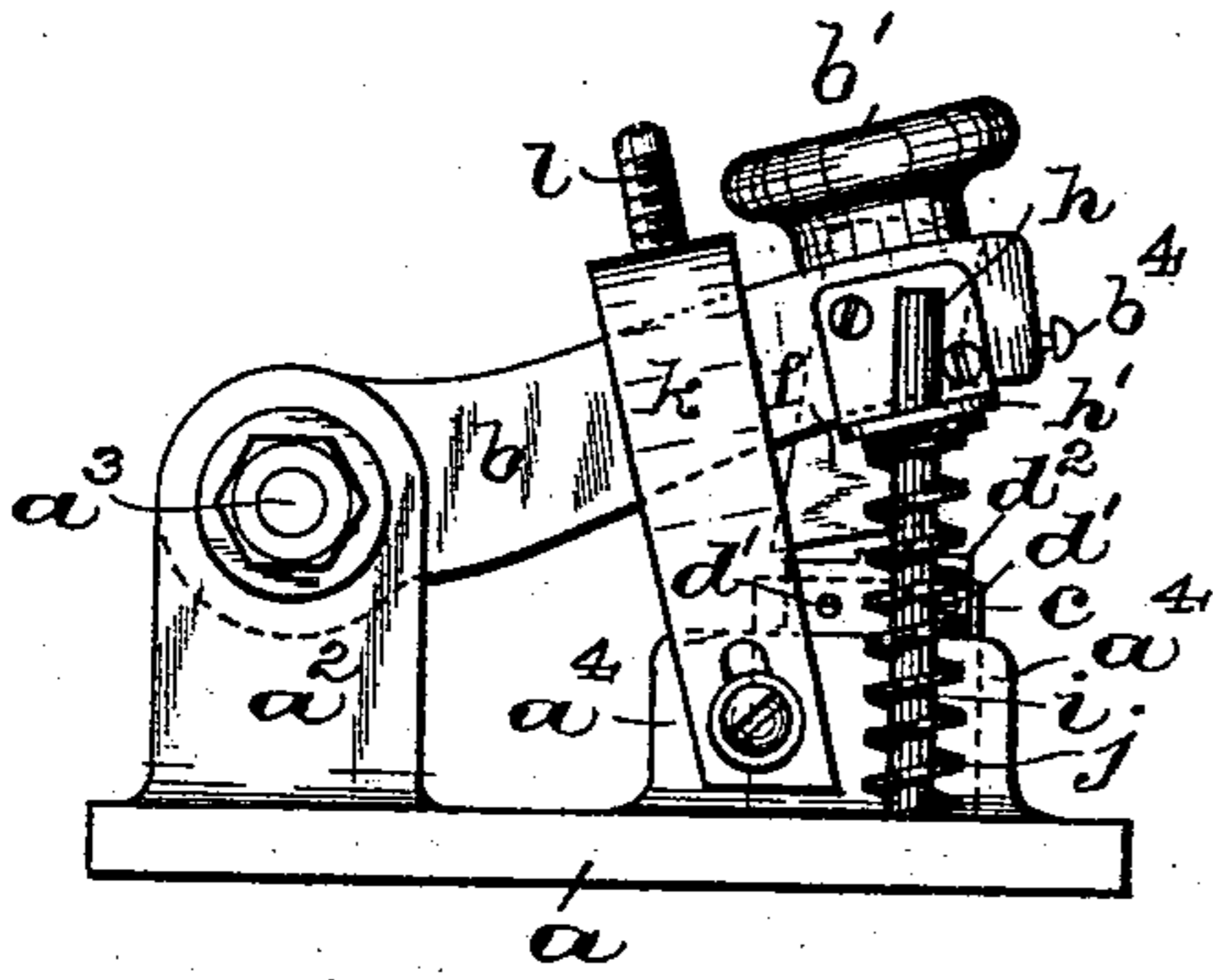

Fig. 1

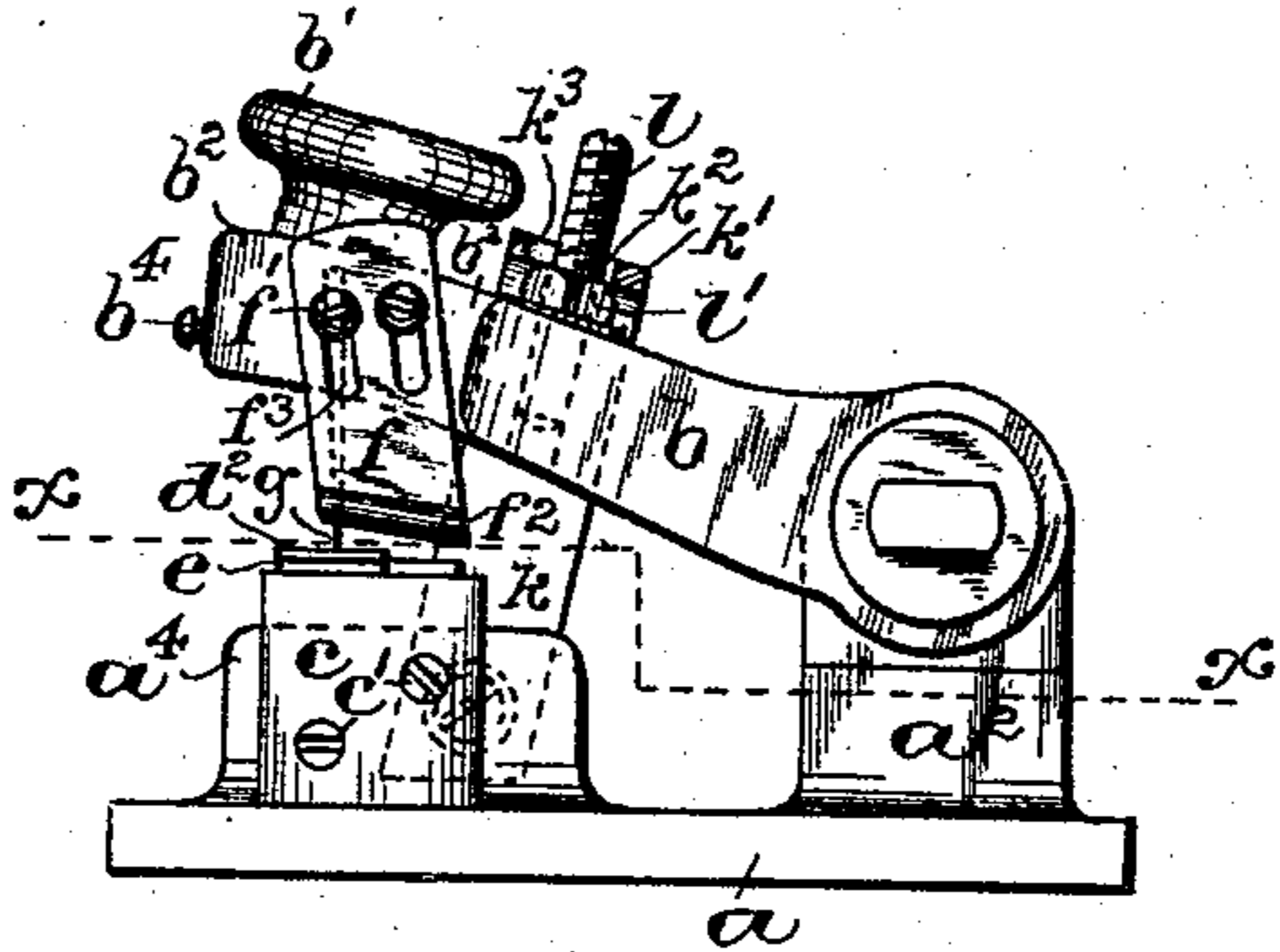

Fig. 2

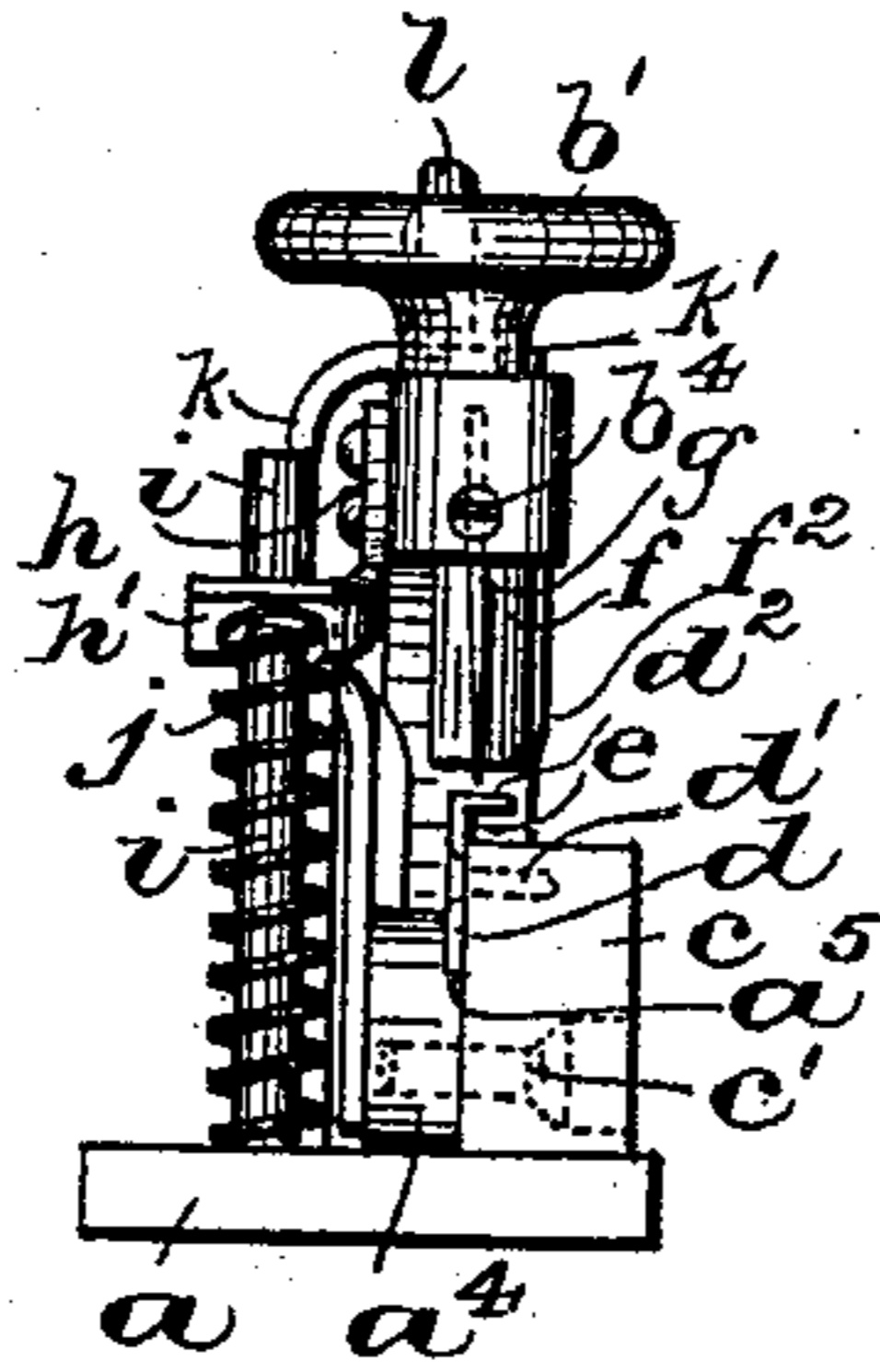

Fig. 3

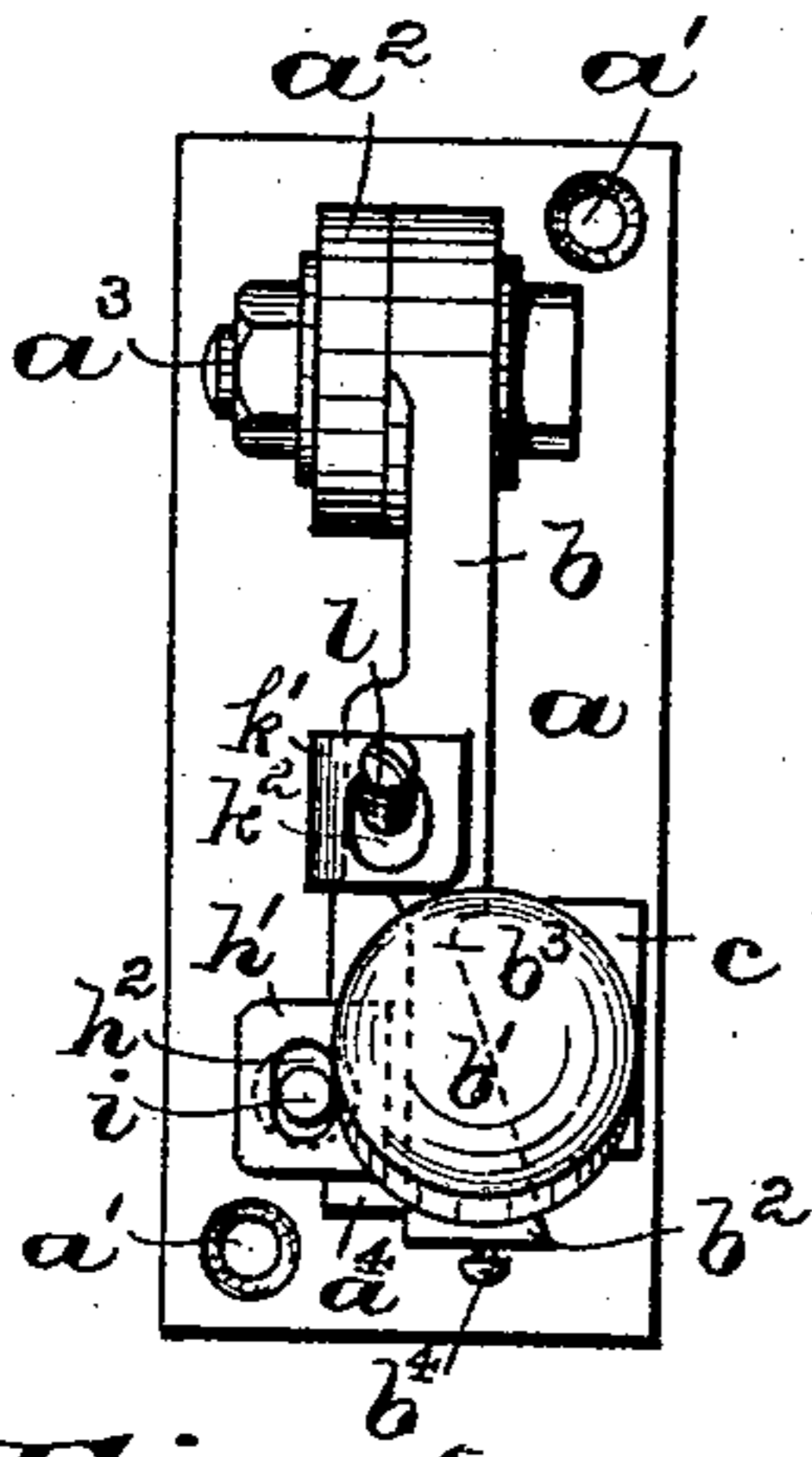

Fig. 4

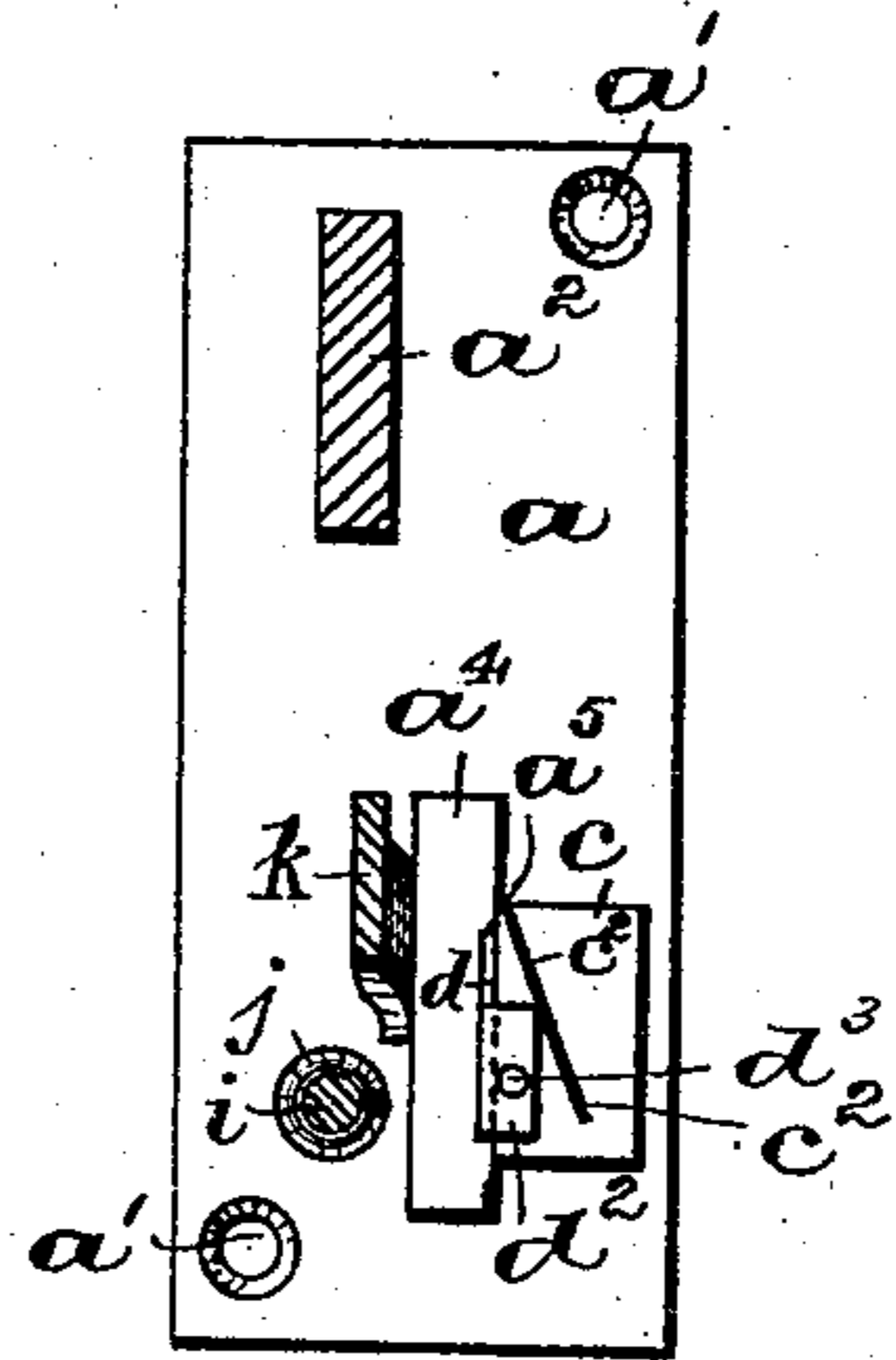

Fig. 5

WITNESSES:

Fred Schuster

G. B. Hooper

INVENTOR:

Joseph Wills,

BY Fred C. Fraentzel, ATT'Y.

UNITED STATES PATENT OFFICE.

JOSEPH WILLS, OF NEWARK, NEW JERSEY.

MACHINE FOR POINTING AND PUNCHING SHOE-LACES.

SPECIFICATION forming part of Letters Patent No. 494,311, dated March 28, 1893.

Application filed August 31, 1892. Serial No. 444,630. (No model.)

To all whom it may concern:

Be it known that I, JOSEPH WILLS, a subject of the Queen of Great Britain, residing at Newark, in the county of Essex and State of New Jersey, have invented certain new and useful Improvements in Machines for Pointing and Piercing Shoe-Laces; and I do hereby declare the following to be a full, clear, and exact description of the invention, such as will enable others skilled in the art to which it appertains to make and use the same, reference being had to the accompanying drawings, and to letters of reference marked thereon, which form a part of this specification.

The purpose of this invention is to provide a machine for the cutting or pointing and the punching or piercing of leather shoe-laces, of that class provided with spirally formed wire end tips, which is of a simple, strong and effective construction; and the essential features of the invention are the arrangement and combination of a support provided with a cutting or punching base, in connection with which is employed a fixed lace guide and stripper combined, and a knife and piercing or punching device, arranged to be brought down upon the lace to cut or point and pierce the same, said cutter and the piercing device being preferably pivotally arranged upon the support in relation to the punching and cutting base and the combined lace guide and stripper.

The devices which have been heretofore used for this purpose, having supplementary clamping levers to which the lace clamp is secured and also means for operating the same, have been of such a construction to make them more difficult to operate and also adding to the cost of construction of the same.

My improved device is designed to remedy this difficulty and to provide a machine which can be readily manipulated and which can be made more economically.

The invention further consists in certain other novel arrangements and combinations of parts, such as will be hereinafter more fully described, and finally embodied in the clauses of the claim.

In the accompanying sheet of drawings, in which similar letters of reference are em-

ployed to indicate corresponding parts in each of the several views, Figures 1 and 2 are the two side views of the machine, illustrating the several parts of the machine in their normal positions ready to be operated. Fig. 3 is a front view, and Fig. 4 is a top view of the machine. Fig. 5 is a horizontal section, taken on line x in Fig. 2, to more clearly illustrate the arrangement of the cutting and punching base and the fixed lace guide and stripper.

This machine for cutting or pointing and punching or piercing shoe laces, shown in said figures, consists essentially of a suitable support a provided with any number of screw or bolt holes a' for securing the device to a table or other support. Arranged at one end of said support a is an upright or post a^2 to which is pivoted by means of a suitable pivotal pin a^3 , an arm b provided near its free end with a punching head or button b' . Near the forward end of said support a , I have arranged an upright a^4 against which may be attached a cutting and punching base c , being preferably secured against the side of said upright by means of screws or pins c' , as will be seen from Fig. 2. Arranged between said upright a^4 and said base c , preferably in a slot or cut-away portion a^5 in said upright a^4 , as will be evident from Fig. 2, is a combined lace guide and stripper, which consists essentially of the body portion d arranged in said slot a^5 , and secured against the side of said base c by means of screws or pins d' , as will be clearly seen from Figs. 1 and 3. Said guide and stripper is provided at the top with a lip d^2 projecting at a right angle, or approximately so, from said body-portion d , above the upper surface of said base c , thereby providing a space e between said base and the under side of said lip d^2 , into which the shoe lace is placed ready for cutting or pointing, and the piercing of the same. As will be seen from Fig. 5, said lip d^2 is also provided with a suitable perforation or hole d^3 , and in the upper surface of said base c is a suitable slot or undercut portion c^2 , arranged to receive the cutting edge of the knife or cutter f , when the shoe lace has been cut and pointed. The pivoted arm b is formed at its forward end in the shape of a wedge, having its widest por-

tion at b^2 and its narrowest portion at b^3 , as will be understood from Fig. 4. The cutter or knife f is secured against this incline thus formed, by means of screws or pins f' , preferably arranged in slots f^3 in said cutter, to render it adjustable, whereby, when the knife is brought down upon the shoe lace, it will be arranged at an acute angle to the front edge of the base c and will correspond with the inclination or direction of the slot or cut-away portion c^2 in said base, into which the cutting edge f^2 of the cutter passes when the lace has been cut and pointed. Directly behind the broad surface of said cutter, and secured in the under side of the arm b , preferably in a perforation therein and held by means of a set screw b^4 , is the punching or piercing needle g , which during the downward movement of the said arm b passes through the hole or perforation d^3 and thereby pierces or punches a hole in the shoe lace placed upon the cutting and punching base c . To one side of said arm b , near the front thereof, is also secured a suitable plate h , having a lip h' provided with an elongated hole h^2 . From said support a extends a post i which passes through said hole h^2 and encircling said post i is a spring j , which is compressed when the arm b is forced downward by the operator and which causes said arm to assume its normal position, after the shoe lace has been cut and pointed, while the lip d^2 on the stationary guide d causes the lace to be stripped from the needle g during the upward movement of the arm, as will be understood. In order to limit the upward movement of said arm b , I have secured to the side of the upright a^4 , a plate k , which may be adjustably secured thereto, as will be seen from Fig. 1, being provided at the top with a lip k' formed at a right angle thereto, which projects out above said arm b and thereby limits the upward movement, as will be evident. In order to limit the downward movement of said arm b , so as to cause the knife edge of the cutter f and the needle g to just pass through the shoe lace, I have arranged upon the upper surface of said arm b an adjusting device. Said device consists essentially of a screw l secured in the top of said arm b and provided with a lock nut l' . The upper portion of said screw projects through an elongated opening k^2 in the lip k' of the plate k , and, as will be evident from Fig. 2, when the arm b is forced down by the operator, the screw l comes in contact with the edge k^3 of said opening and thus limits the downward movement of both the arm b and the cutter f arranged thereon.

The operation of the machine will be understood from the above description, the shoe lace being placed against the guide d beneath the lip d^2 , the knife or cutter being brought down to cut or point the lace, while at the same time the needle g pierces or punches a hole in the lace, and while the

parts of the machine return to their normal positions, the under side of the lip d^2 serves to strip the lace from the needle g .

The primary advantage of my invention is to avoid any double handling of the shoe lace by first pointing the same, and piercing the hole for the reception of the spirally formed wire tip-piece, both these operations being performed at one time, and also in my machine, avoiding the use of a clamping mechanism and means for operating the same. It is this feature of my invention which I wish to claim broadly, and which I deem of the greatest importance, since it saves time in the handling of the shoe laces to be pointed and pierced, as there is no time lost in first operating a clamping device and the intermediately arranged mechanism for operating the same.

I have found by practice that the best results can be obtained with a machine built on the principles of the machine herein shown and claimed.

Of course it will be evident, that certain changes in the details of construction of my machine may be made without departing from the scope of my invention, hence I do not wish to be understood as limiting myself to the exact form of construction herein shown.

Having thus described my invention, what I claim is—

1. In a machine for pointing and piercing shoe laces, the combination, with a support a , having a post a^4 , a cutting and punching base secured to said support, and a combined guide and stripper secured between said post a^4 and said base, of a cutter and a punching or piercing device, substantially as and for the purposes set forth.

2. In a machine for pointing and piercing shoe laces, the combination, with a support a , having a post a^4 , a cutting and punching base secured to said support, and a combined guide and stripper secured between said post a^4 and said base, of a pivoted operating arm b , a cutter and a punching or piercing device on said arm, substantially as and for the purposes set forth.

3. In a machine for pointing and piercing shoe laces, the combination, with a support a , having a post a^4 , a cutting and punching base secured to said support, and a combined guide and stripper secured between said post a^4 and said base, of a pivoted operating arm b , a cutter and a punching or piercing device on said arm, and a spring connected with said arm b for causing its return when depressed, substantially as and for the purposes set forth.

4. The herein described machine for pointing and piercing shoe laces, comprising therein, a support a provided with a pivoted operating arm b having a punching knob b' , a knife and a piercing needle on said arm, a cutting and punching base c on said support

2, and a combined guide and stripper connected therewith, and means connected with said arm to limit its upward as well as its downward movement, consisting of a plate *k* having
5 a lip *k'* and an elongated hole in said lip, and a screw *l* secured in the top of said arm *b* and passing through said hole in said lip, substantially as and for the purposes set forth.

In testimony that I claim the invention set forth above I have hereunto set my hand this 10
30th day of August, 1892.

JOSEPH WILLS.

Witnesses:

FREDK. C. FRAENTZEL,
WILLIAM O'BRIEN.