

(No Model.)

W. SCOTT.

PASTING MECHANISM FOR PRINTING PRESSES.

No. 494,233.

Patented Mar. 28, 1893.

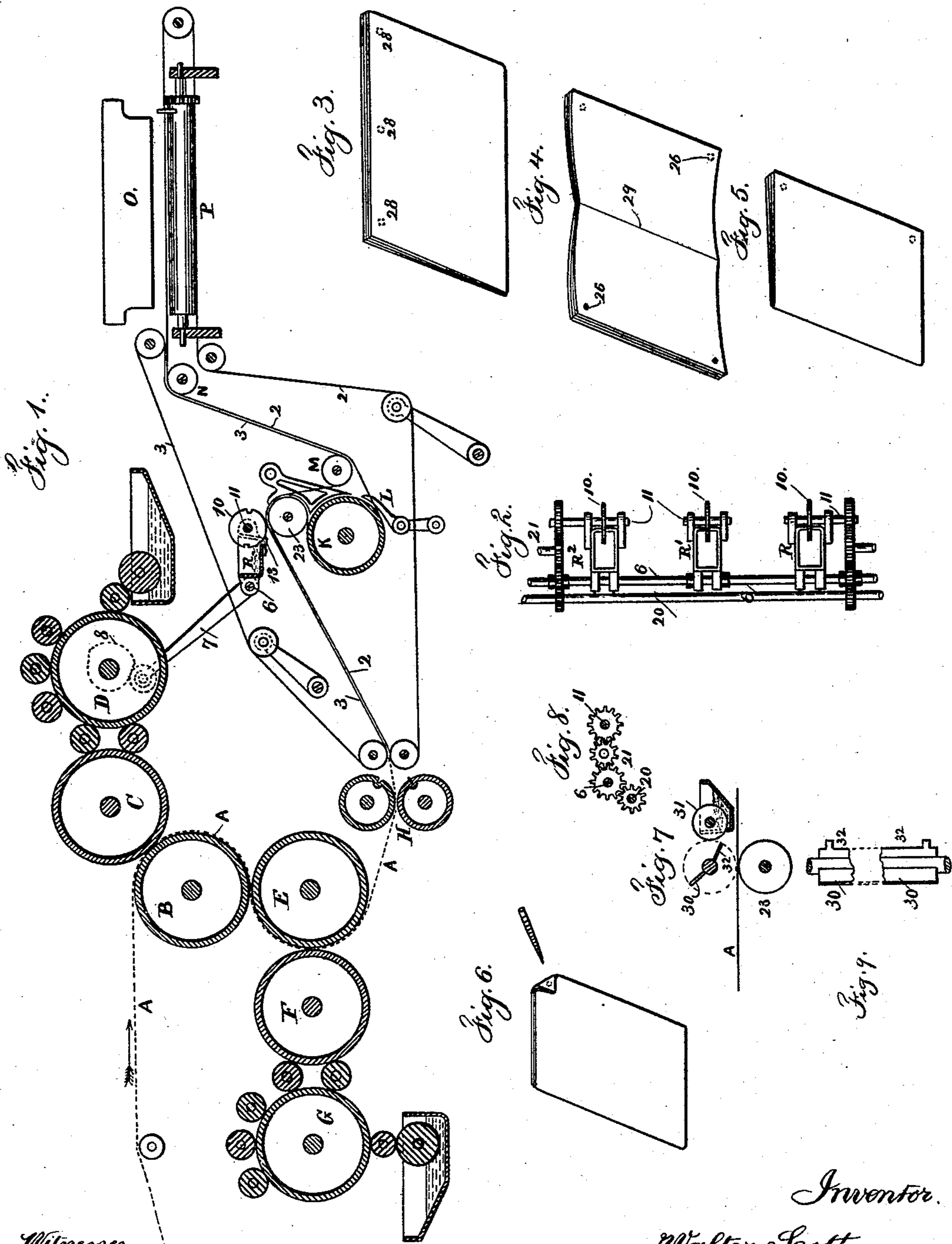

Witnesses
Char. H. Smith
J. Stair

Inventor.
Walter Scott
per Lemuel W. Serrell
attys

UNITED STATES PATENT OFFICE.

WALTER SCOTT, OF PLAINFIELD, NEW JERSEY.

PASTING MECHANISM FOR PRINTING-PRESSES.

SPECIFICATION forming part of Letters Patent No. 494,233, dated March 28, 1893.

Application filed December 9, 1889. Serial No. 333,088. (No model.)

To all whom it may concern:

Be it known that I, WALTER SCOTT, a citizen of the United States, residing at Plainfield, in the county of Union and State of New Jersey, have invented an Improvement in Pasting Mechanism for Printing-Presses, of which the following is a specification.

Daily and weekly newspapers, and periodicals are often furnished by the publishers to news-dealers and venders upon condition that the unsold papers may be returned and a suitable deduction made for the same, but it is found that frauds are often practiced, by said dealers and venders gathering up papers that have been sold and used, and returning them as unsold to the publishers.

The object of my present invention is to secure the leaves of such newspaper or periodical together, in a simple and easy manner, so that the securing device will be mutilated by the party reading the paper, thereby frauds are prevented, because the paper will indicate readily whether it has been sold and used or not. To accomplish this object I apply paste or adhesive material in spots upon the margins of the sheets in such a way, that in the collecting or folding operation, the printed sheets are caused to adhere together at places sufficiently near to each other to prevent the paper being read easily without separating the sheets one from the other at the spots where they adhere.

In the drawings Figure 1. is a diagrammatic vertical section, representing the printing, pasting, collecting and folding mechanism. Fig. 2. is a plan view of the paste troughs. Figs. 3., 4., 5., 6. illustrate the folded newspaper or periodical having the spots or adhering portions near the margins for the purposes aforesaid. Fig. 7. illustrates a transverse pasting device. Fig. 8. is an elevation of the gearing for rotating the pasting disks, and Fig. 9. is a plan view of a portion of the pasting blade shown in Fig. 7.

It is to be understood that the devices represented in Fig. 1. are illustrative of printing, gathering and folding mechanism, and that my improvements are available with any kind of printing, gathering, associating, or folding device. The web of paper supplied to the machine is represented at A: and B, is the first

impression cylinder: C the first type cylinder D the ink distributing cylinder: E the second impression cylinder: F the second type cylinder: G the second ink distributing apparatus, and the sheet A as it is printed passes between the cutting apparatus H and by the ranges of belts 2. and 3. to the cylinder K upon which two or more sheets are imposed or accumulated, and I represents the fingers that direct the first sheet as it passes around the cylinder K, in order that the second sheet may be laid upon the same, and the sheets when discharged from the accumulating or imposing cylinder K. pass beneath the roller M. and by the belts to the roller N. of the folding apparatus, in which O. represents the folding blade, and P. the rolls between which the sheet is folded. These parts are substantially similar to those represented in my patent No. 398,544 granted February 26, 1889, and further description of the same is unnecessary, and my improvements are available with presses that fold the web, or slit it, or turn one part of the web over on another part or bring the sheets together in any desired manner.

The troughs R. R'. R² for paste or adhesive material are represented as supported by the rock shaft 6, and to this rock shaft 6. an arm 7. is connected that is moved by a cam of any suitable character upon any part of the printing or folding mechanism. A cam is represented at 8. upon the shaft of the ink distributor D for rocking the shaft and the paste trough that are connected to it. At the moving end of these paste troughs any suitable pasting mechanism is made use of. I prefer to employ the disks 10. upon shafts 11. which are revolved by suitable means, such as a belt, pulley or gear wheel, and there is upon the paste trough a wiper 13. that keeps the edge of the disk 10. free from paste except where such disk is notched. It is preferable to make the paste troughs R. R'. R². in short sections that can be slipped along upon the cross shaft 6. and secured at any desired place so that the spots, or lines of paste can be applied upon the margins of the printed sheets in the proper positions. By properly placing the cam 8. and timing the revolution of the shafts 11. the spots of adhesive material can be applied to the margins of the sheets in the de-

sired places, the rocking motion given to the shaft 6. lifting the pasting disks from the surface of the paper or bringing them into contact therewith, and such disks may in some cases be rotated by the contact of their edges with the paper. Where a continuous line of paste is required, one of the paste troughs is loosened from the rock shaft 6. so that its disk may rest on the paper for a line of paste at the fold of the sheet as heretofore usual, the wiper being adjusted to allow the proper quantity of paste to remain upon the edge of the disk.

A convenient means for revolving the pasting disks, is a continuously revolving shaft 20. and train of gearing 21. to the shafts of the paste disks, one gear in each train being upon the shaft 6. so that the gears remain in contact as the paste troughs are rocked with the shaft 6. When the paste troughs remain stationary, the roll 23 may be raised or lowered as the motion required is very small.

The revolving paster represented in Figs. 7. and 9. applies the paste to the web transversely where the paper is to be folded, and also to the surfaces near the transverse margins. The paste roll 31. is in a trough as usual, and the edges of the rotary blades 30. and 32. come into contact and take paste from such roll 31. The blade 30. is not exactly opposite to the blade 32. but at about one hundred and seventy degrees distant, in order that the blade 30. may apply the paste where the fold is to take place and the blade 32. may apply paste near the edges and upon the imprinted margins of the sheet, and this blade 32. is not continuous but is cut away so as to have two or more projections that apply the paste at the desired places. This transverse paster is to be located in the press according to the manner of associating the sheets. If several sheets are to be imposed on the cylinder K. and afterward folded transversely, this pasting device will be applied upon the web either just before or just after the cutters H. act upon the same. If the sheets are carried to the folder without being imposed, then the pasters 30. 32. will apply the paste to the passing sheets as they go to the folder, and by using the pasters 10. as before described, the paste can be applied in one or more longitudinal lines and in spots wherever desired, in addition to the paste deposited by the blades 30. and 32. according to the folds that are to be made in the sheets and the extent to which it is desired to unite the margins by the spots of paste.

The adhesive material may be colored so as to make the spots prominent, and easily noticed, and the spots of paste may be of any desired shape.

From the foregoing description it will be

apparent that lines or dots of paste or adhesive material can be applied to the margins of printed sheets wherever desired. Such sheets pass to the imposing cylinder where two or more are collected, or as such sheets are passed to the folding mechanism where two or more sheets may be brought together, or where different parts of the same sheet are caused to adhere by the paste as they come together in folding. Where two or more webs are brought together, after being printed, my present improvements are equally available. An awl notched or corrugated on its sides, and dipped in paste as seen in Fig. 6. may be thrust through the paper after it is folded, and carry the necessary amount of paste to stick the sheets together, and the invention is equally available in printing presses where a paste blade is applied transversely of the web on the line of the fold.

In Fig. 7. I have shown a pasting blade 30. the edge of which comes into contact with the paste roller 31. and then applies a line of paste centrally of the margin, and transversely of the web at the line where the sheets are to be folded, and the blade 32. is made with points where the spots of paste are to be applied, and this blade is not directly opposite to the blade 30. but at a distance of say one hundred and seventy-eight degrees in order that the spots of paste may not be on the line of the edge of the sheet, but at the proper distance therefrom to apply the spots on the margin, near to the edge of the sheet.

I claim as my invention--

1. The combination with the paste trough and its roller, of the rotary pasting blades 30. and 32. at about one hundred and seventy degrees distant from each other and the blade 32. notched on its edge so as to apply paste in spots near the edges of the sheets, and the blade 30. to apply a transverse line of paste to the web where the same is to be folded substantially as set forth.

2. The combination with the printing, cutting and folding mechanism, of the rotary pasting blades 30. and 32. at about one hundred and seventy degrees distant from each other, the blade 32. being notched on its edges so as to apply paste in spots near the edges of the sheet and the blade 30. to apply a transverse line of paste to the web where the same is subsequently folded, and the movable paste troughs and paste rollers 10. to apply paste in spots upon other parts of the margins of the sheets substantially as specified.

Signed by me this 2d day of December, 1889.
WALTER SCOTT.

Witnesses:

GEO. T. PINCKNEY,
WILLIAM G. MOTT.