

(No Model.)

C. C. STROTHER. CAR COUPLING.

No. 459,128.

Patented Sept. 8, 1891.

Fig. 1.

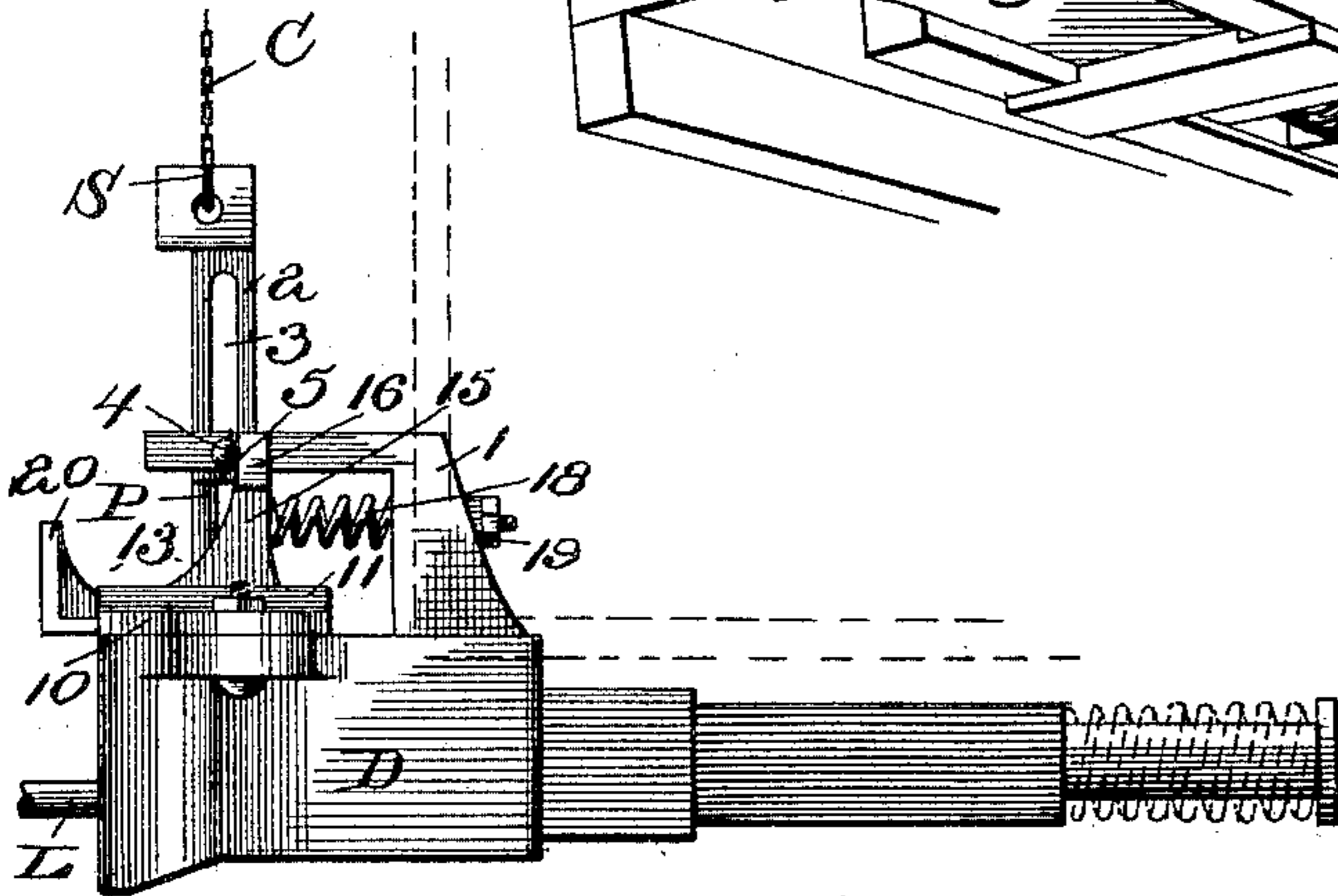
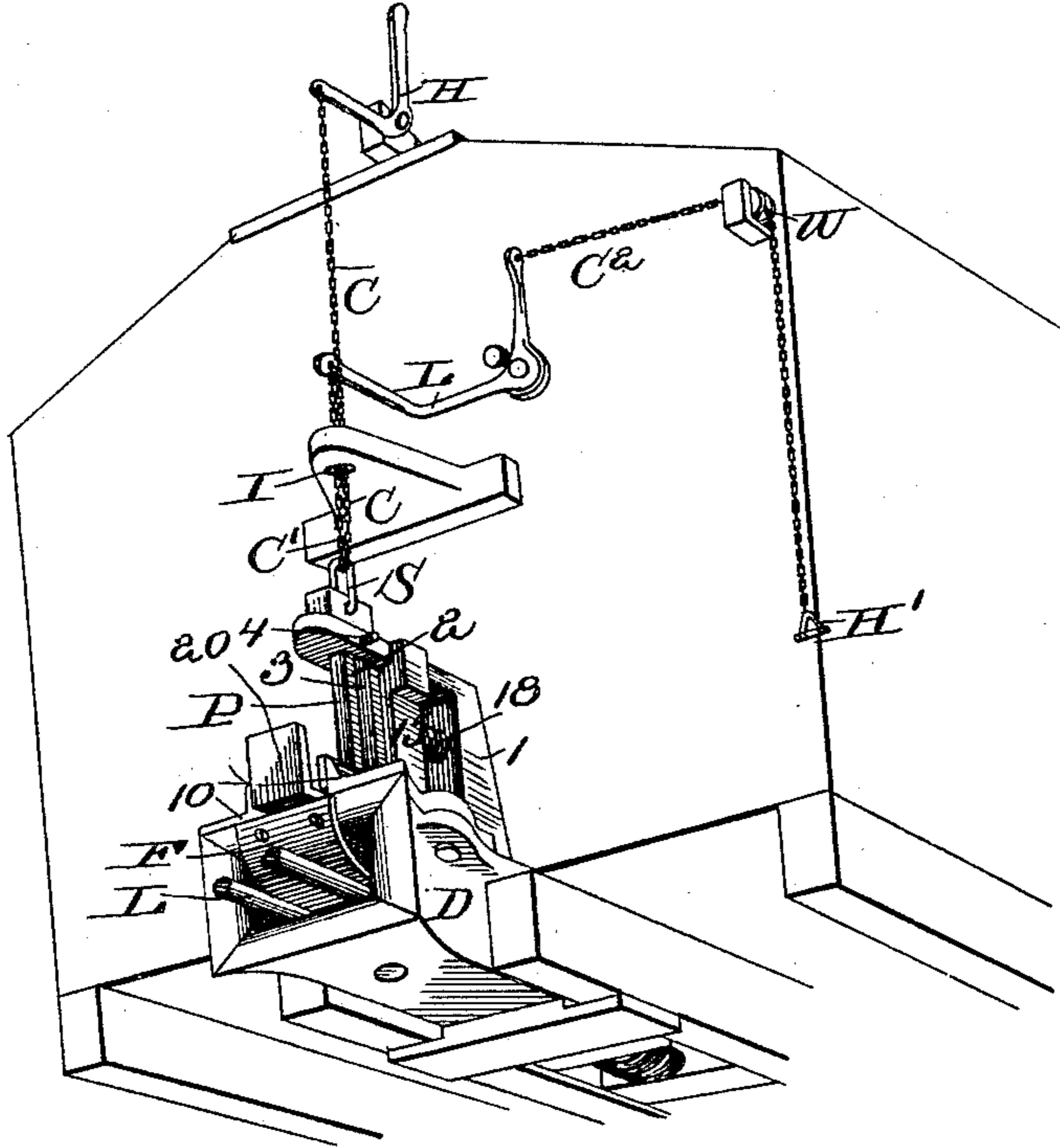

Fig. 2.

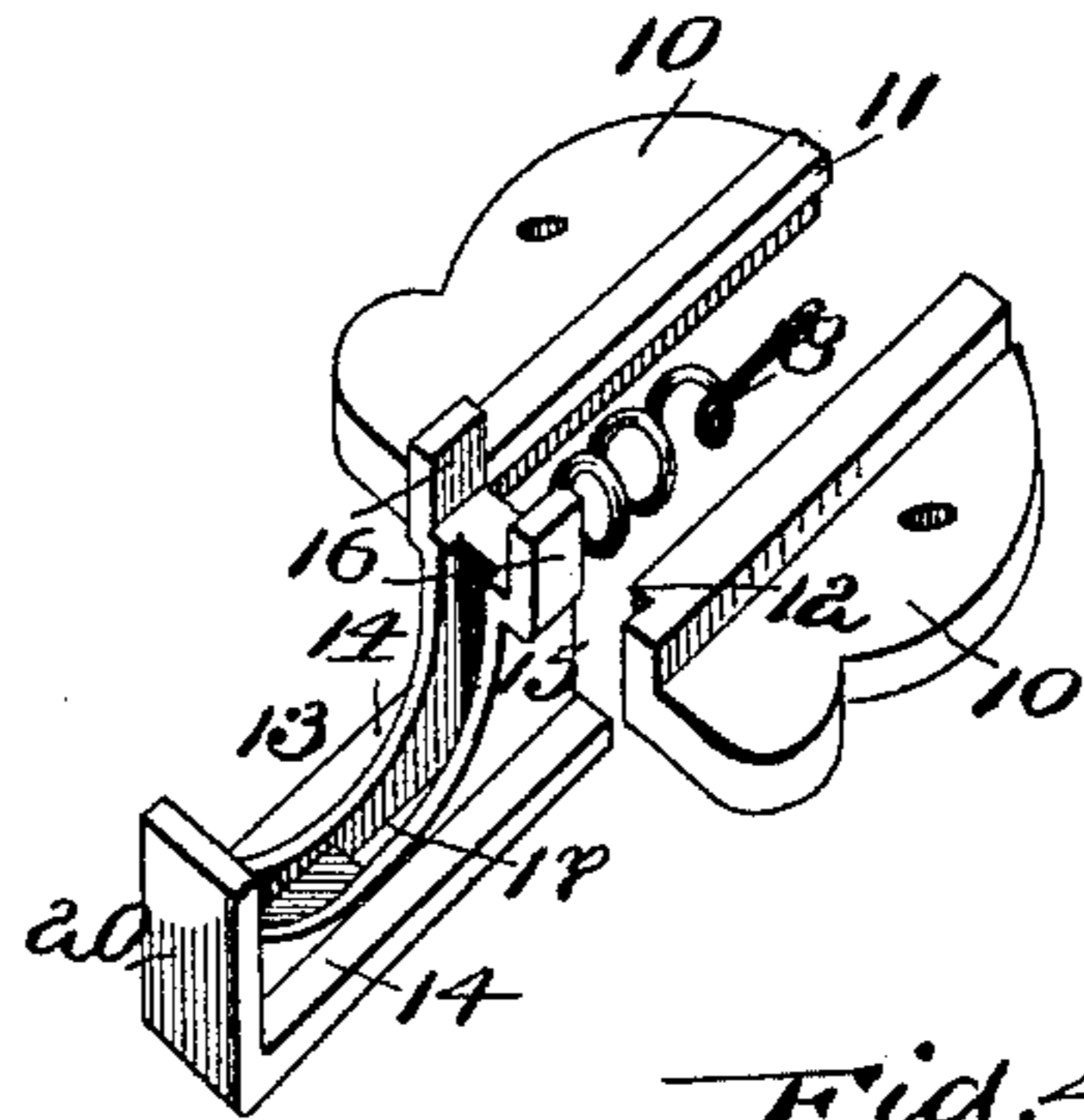

Fig. 4.

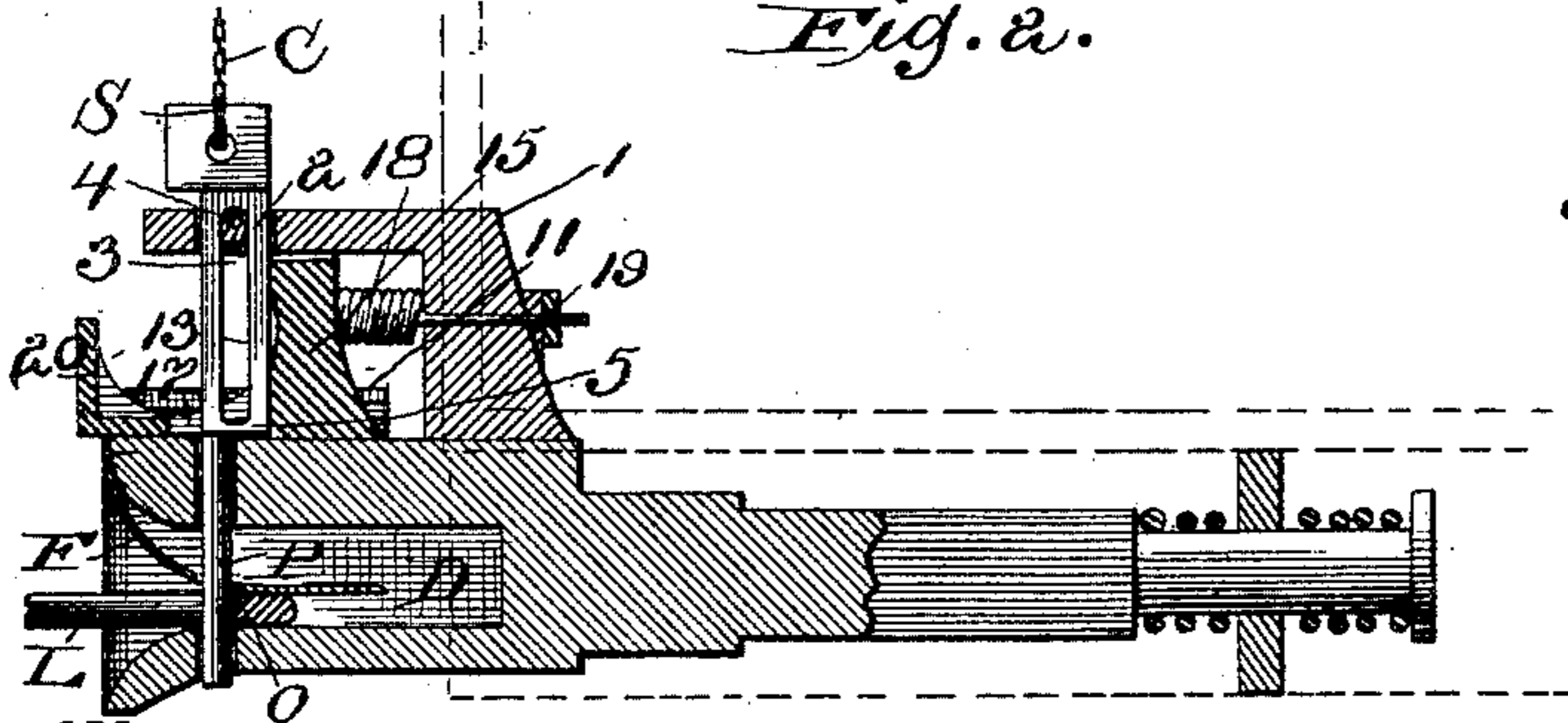

Fig. 3.

Witnesses

Inventor

Arthur Ashley

N. J. Coomer

By his Attorneys,

Charley C. Strother

C. A. Snow & Co.

UNITED STATES PATENT OFFICE.

CHARLEY CRABTRE STROTHER, OF CALIFORNIA, MISSOURI.

CAR-COUPLING.

SPECIFICATION forming part of Letters Patent No. 459,128, dated September 8, 1891.

Application filed June 9, 1891. Serial No. 395,691. (No model.)

To all whom it may concern:

Be it known that I, CHARLEY CRABTRE STROTHER, a citizen of the United States, residing at California, in the county of Moniteau and State of Missouri, have invented a new and useful Car-Coupling, of which the following is a specification.

This invention relates to car-couplings, and more especially to that class thereof known as "gravity pin-supports;" and the object of the same is to produce certain improvements in devices of this character.

To this end the invention consists in the specific details of construction hereinafter more fully described and claimed, and as illustrated on the sheet of drawings, wherein—

Figure 1 is a partial perspective view of a car having my coupling attached. Fig. 2 is a side elevation of the draw-head with the pin raised. Fig. 3 is a central vertical longitudinal section of the draw-head with the pin lowered through the link. Fig. 4 is an enlarged perspective detail of the sliding pin-support and the guides therefor slightly separated.

Referring to the said drawings, the letter D designates a draw-head mounted beneath a car-body and having suitable cushioning-springs. L is the link passing into the open mouth of this draw-head.

P is the pin passing through the vertical pin-opening in the draw-head and through the link, and C is a cord or chain leading upwardly from this pin through an eye I in the end of the car to a handle H at the top thereof, its lower end being preferably connected to the link by a clevis or shackle S, and C' is another chain leading from this shackle through the eye to a bell-crank lever L, pivoted on the end of the car and from whose other arm another chain C² leads outwardly over a pulley or wheel W and has a handle H' on its end. By these handles an operator on the top of the car or at the side of the track can lift the pin as will be clear. The link is held in horizontal position by a flat spring F, secured within the draw-head near its mouth, having an opening O through which the pin passes, and its rear end bear-

ing downwardly on the link when the latter is in place, as seen in Fig. 3.

1 is an L-shaped bracket having its base secured upon the draw-head and having one arm extending forwardly over the pin-opening, where it is provided with a hole through which the enlarged body 2 of the pin passes vertically. Said enlarged body has a vertical slot 3, which is engaged by a transverse pin 4 through the opening in this bracket to prevent the dislocation of the pin and the lower end of the latter is reduced, thereby forming a shoulder 5, all as best seen in Fig. 3.

Secured upon the top of the draw-head near its front end at each side of the pin-opening is a guide 10, whose inner edge 11 is raised and whose front corner is notched, as at 12.

13 is a pin-support having flanges 14 at its sides, which move beneath the inner edges 11 of the guides 10 and upon the body of the draw-head D, having a turned-up and enlarged front end 20, whose edges move into the notches 12 when the support is driven to the rear, having an arm 15 rising from its rear end and forked at 16, where it slides beneath the forwardly-extending arm of the bracket 1, and having an elongated hole or opening 17 through its body, and this support is pressed normally forward by a spring 18 between its arm 15 and the bracket 1, the rear end of this spring passing through said bracket and having a nut 19.

In operation one of the handles is drawn upon to raise the pin P, whose slot 3 moves over the transverse pin 4 in the opening in the bracket until its shoulder 5 passes above the fork 16 of the arm 15, when the spring 18 throws the support forwardly, its flanges 14 sliding beneath the edges 11 of the plates 10, as will be clear. The fork 16 thus comes beneath the shoulder 5 on the pin P and holds the latter raised, while the enlarged front end 20 of the support is projected slightly beyond the front end of the draw-head. Another car now approaching, with a link L projecting from its draw-head D, the link moves into the mouth of the draw-head illustrated and beneath the flat spring F, and the enlarged front end of the other draw-head strikes the similar end 20 on this one. The support 13

is thereby moved to the rear against the tension of the spring 18, the opening 17 in the support moving astride the pin, and as soon as the fork 16 passes from beneath the shoulder 5 the pin drops, its reduced lower end passing through the link, which at this time is driven far into the draw-head.

It will thus be seen that my improved car-coupling is automatic in its action when used in connection with any other form of draw-head which will drive the support to the rear and which uses a link, and the uncoupling can be done from the top of the car or from the ground.

The devices on the draw-head can be applied to the draw-heads already in use, or the entire cost of manufacturing the car-coupling is but a trifle more than that of many of those now made.

I do not limit myself to the exact details of construction, as considerable change may be made therein without departing from the spirit of my invention.

What is claimed as new is—

1. In a car-coupling, the combination, with the draw-head having a vertical pin-opening, an upwardly and forwardly extending bracket on said draw-head having an enlarged opening over said pin-opening, a transverse pin through said enlarged opening, and a coupling-pin having its lower end reduced and passing through the draw-head and provided with a slot above the shoulder thus formed, the slotted portion passing through said enlarged opening with the slot astride said transverse pin, of means for raising said pin, and a spring-actuated pin-support normally engaging said shoulder and adapted to be disengaged therefrom by the impact of the draw-heads, substantially as described.

2. In a car-coupling, the combination, with the draw-head having a vertical pin-opening, a bracket mounted on the draw-head and having an opening in alignment with the pin-opening, a coupling-pin moving in said opening, and means for raising it, of longitudinal guides on the draw-head, a pin-support moving between them and having an upturned arm at its rear end, and an expansive spring

between said arm and bracket, the support holding the pin elevated when it is moved forwardly, substantially as described.

3. In a car-coupling, the combination, with the draw-head having a vertical pin-opening, a bracket mounted on the draw-head and having an opening in alignment with the pin-opening, a coupling-pin moving in said openings and having a downwardly-facing shoulder on its rear side, and means for raising the pin, of guides upon the draw-head having raised inner edges provided with notches at their front corners, a pin-support moving between said edges and having flanges passing beneath them, the support having an enlarged front end adapted to be seated in said notches and having an upwardly projecting arm at its rear end, whose upper extremity is forked and moves beneath the bracket, the body of said support having an elongated opening moving astride the pin, and an expansive spring between said arm and bracket, substantially as described.

4. In a car-coupling, the combination, with the draw-head having a vertical pin-opening, a bracket mounted on the draw-head and having an opening in alignment with the pin-opening, a coupling-pin moving in said openings and having a downwardly-facing shoulder on its rear side, the body of the pin above said shoulder being slotted, a transverse pin through the opening in the bracket and through said slot, and chains leading upwardly from said pin to the top of the car and over a bell-crank lever to the side of the car and carrying handles, of a spring-actuated pin-support normally engaging said shoulder and adapted to be disengaged therefrom by the impact of the draw-heads, substantially as and for the purpose hereinbefore described.

In testimony that I claim the foregoing as my own I have hereto affixed my signature in presence of two witnesses.

CHARLEY CRABTRE STROTHER.

Witnesses.

MILES ALLEE,
SAML. H. STROTHER.