

T. NORDENFELT.
GUN.

No. 454,374.

Patented June 16, 1891.

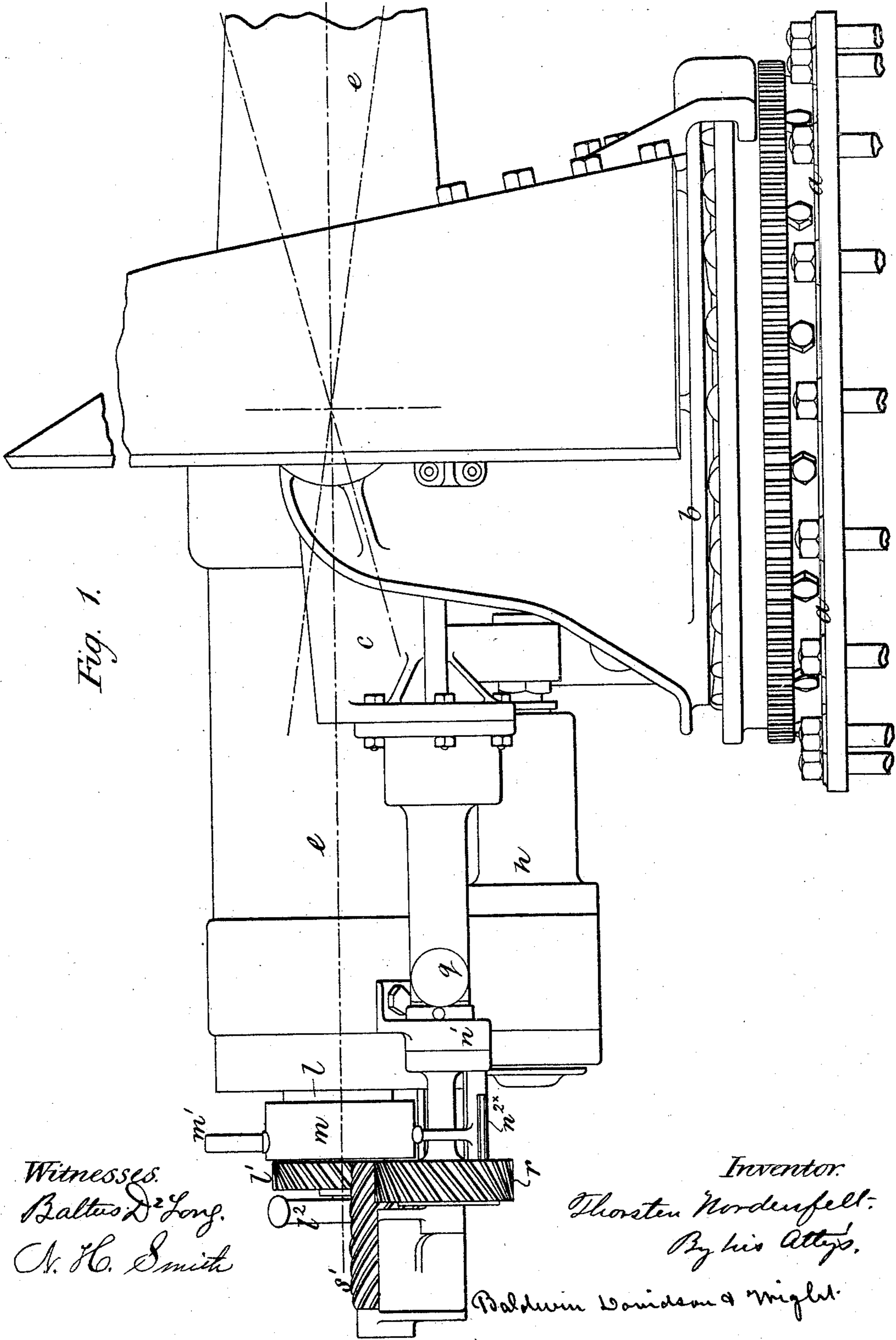

Fig. 1.

Witnesses:
Baltus De Long.
A. H. Smith

Inventor:
Thorsten Nordenfelt.
By his Atty.

Baldwin Davidson & Wright.

T. NORDENFELT.
GUN.

No. 454,374.

Patented June 16, 1891.

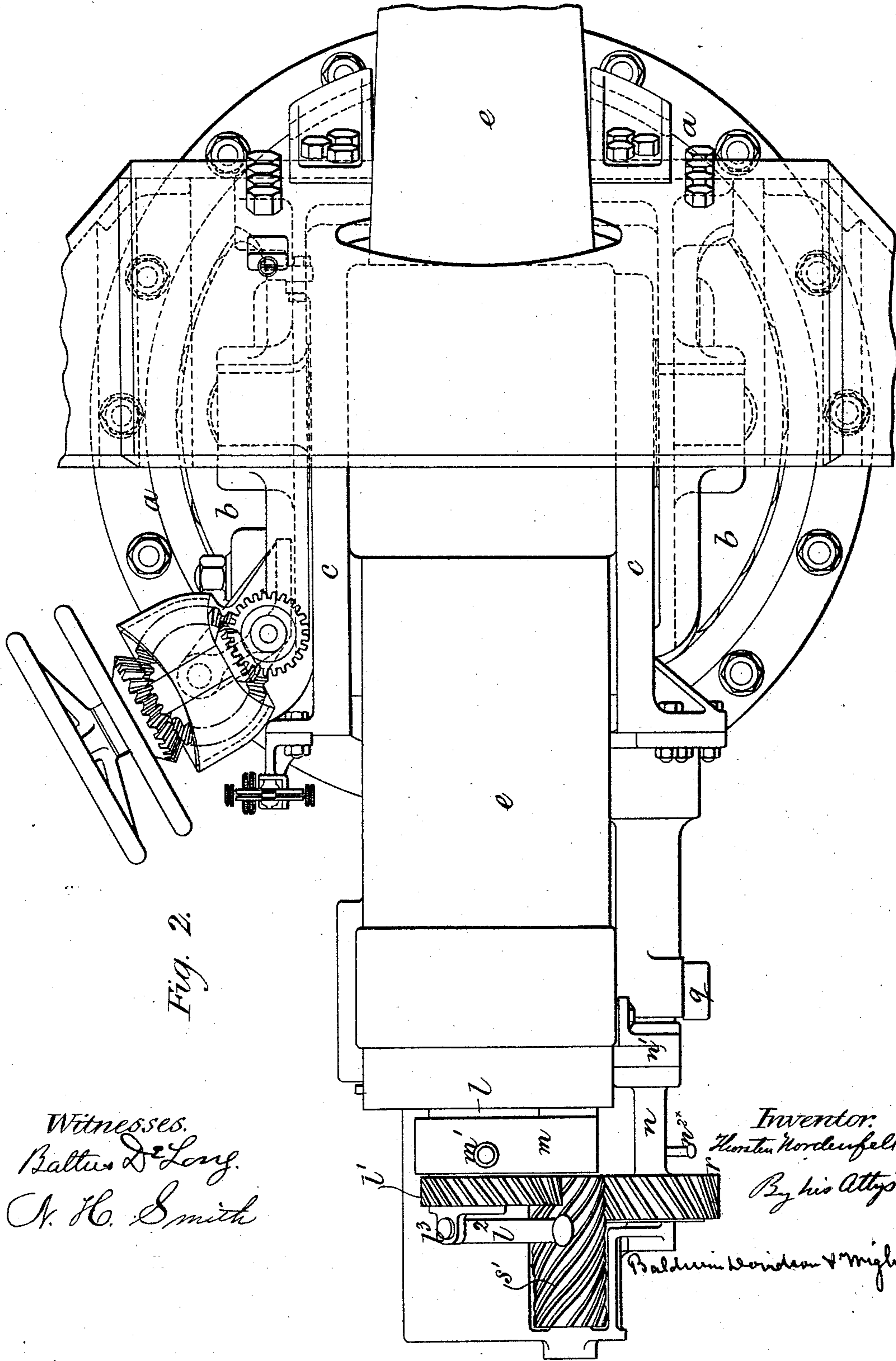

Fig. 2.

Witnesses.
Baltus DeLong.
A. H. Smith

Inventor:
Thorsten Nordenfelt.
By his Atty's.

Baldwin, Bonden & Wright

T. NORDENFELT.
GUN.

No. 454,374.

Patented June 16, 1891.

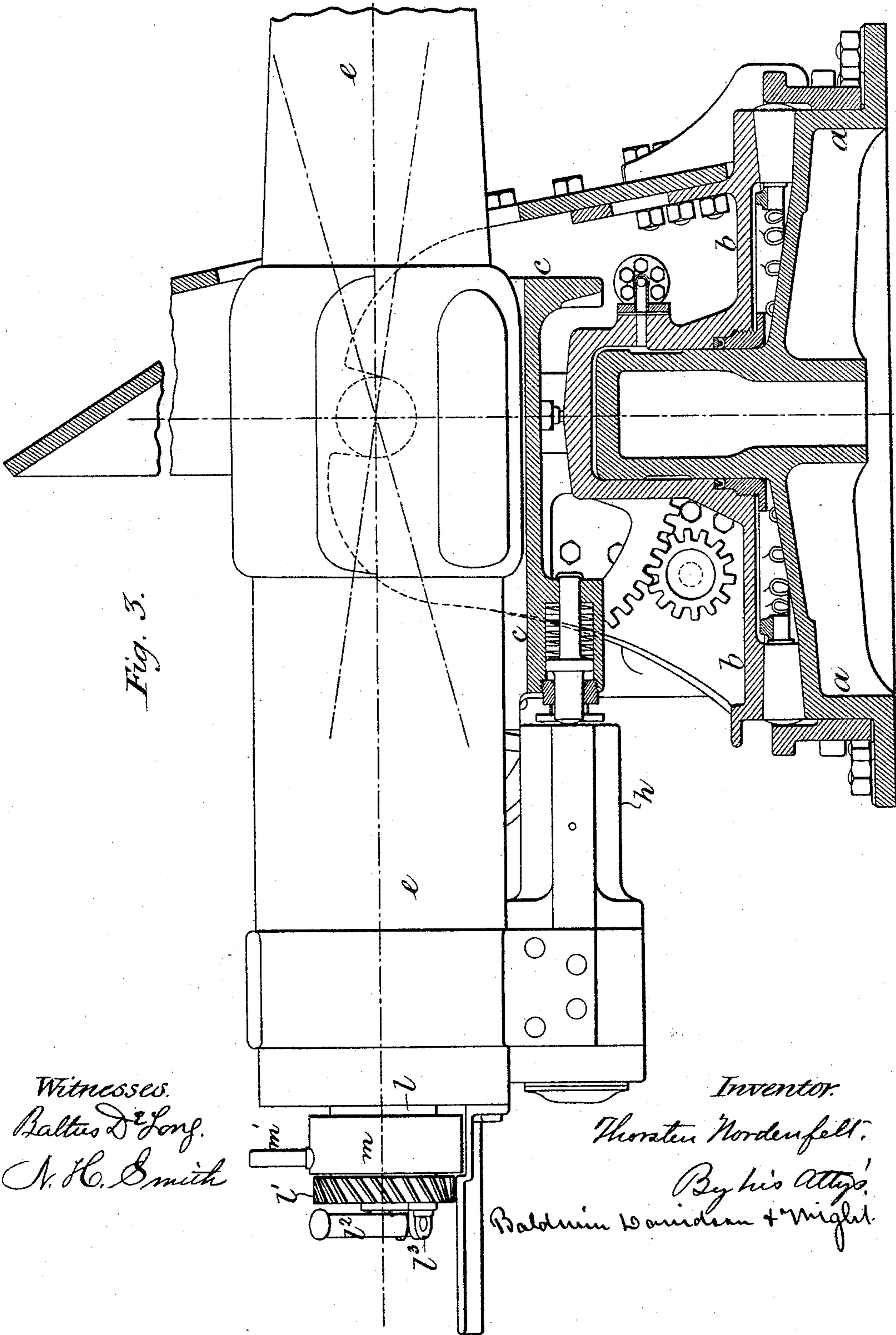

Fig. 3.

Witnesses.
Baltus D. Long.
A. H. Smith

Inventor.
Thorsten Nordenfelt.
By his Atty's.
Baldwin Davidson & Wright.

(No Model.)

6 Sheets—Sheet 4.

T. NORDENFELT.
GUN.

No. 454,374.

Patented June 16, 1891.

Fig. 4.

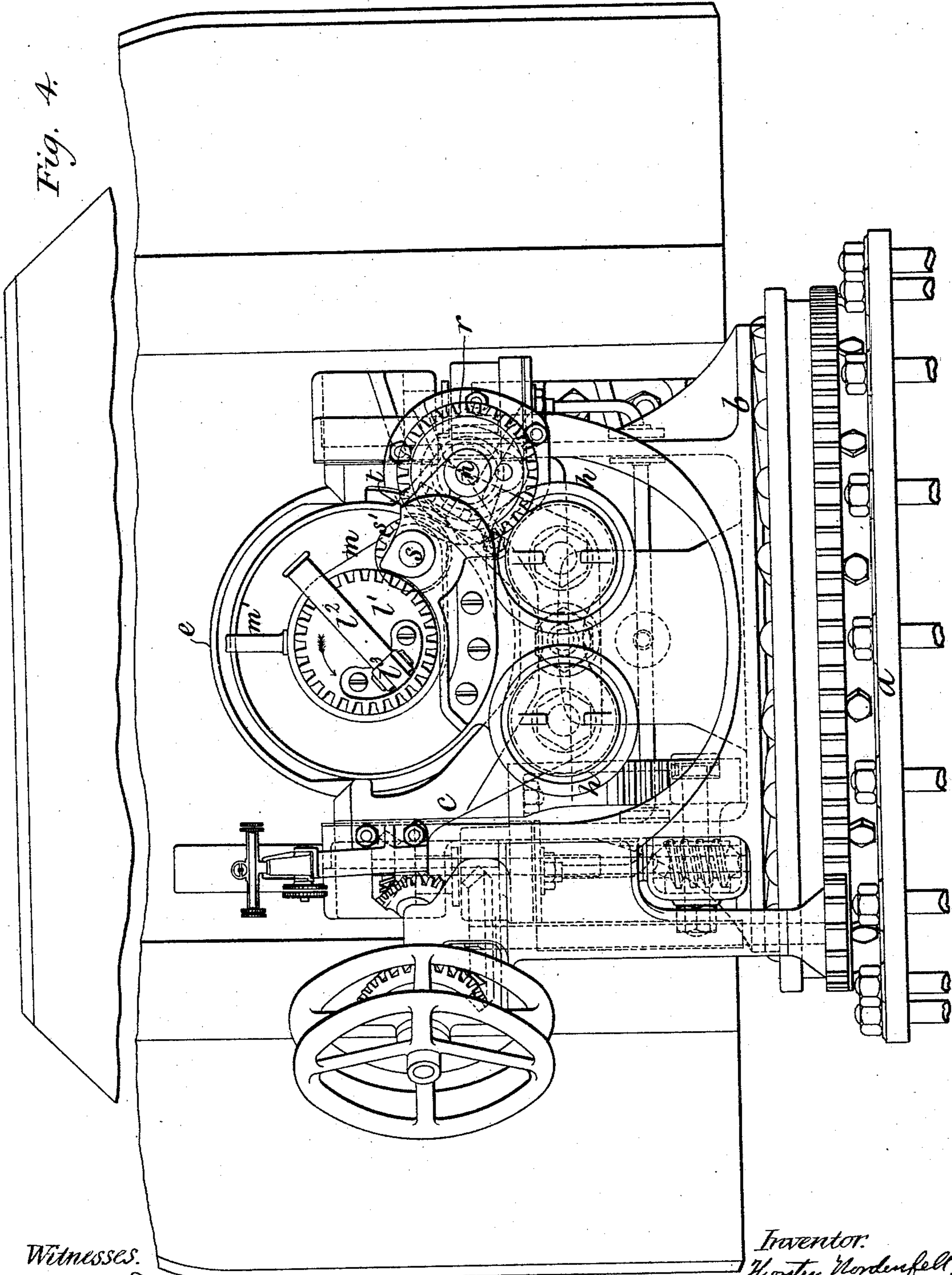

Witnesses.

Baltus D. Long.
A. H. Smith

Inventor.

Thorsten Nordenfelt.
By his Atty's.

Baldwin Davidson & Migher.

T. NORDENFELT. GUN.

No. 454,374.

Patented June 16, 1891.

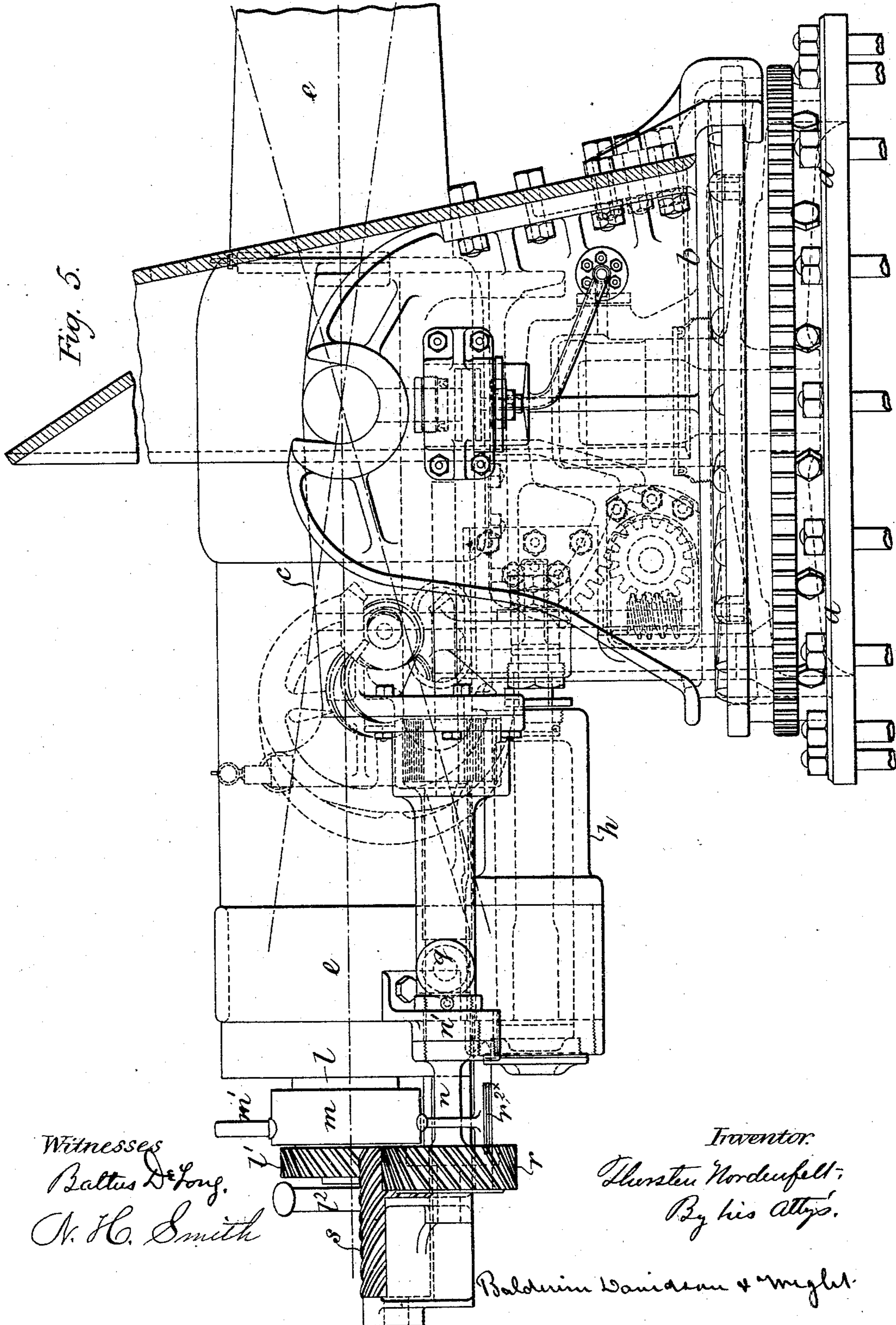

Witnesses
Baltus DeLong.
A. H. Smith

Inventor:
Thorsten Nordenfelt;
 By his Atty's.

Baldwin Davidson & Wright.

T. NORDENFELT.
GUN.

No. 454,374.

Patented June 16, 1891.

Fig. 6.

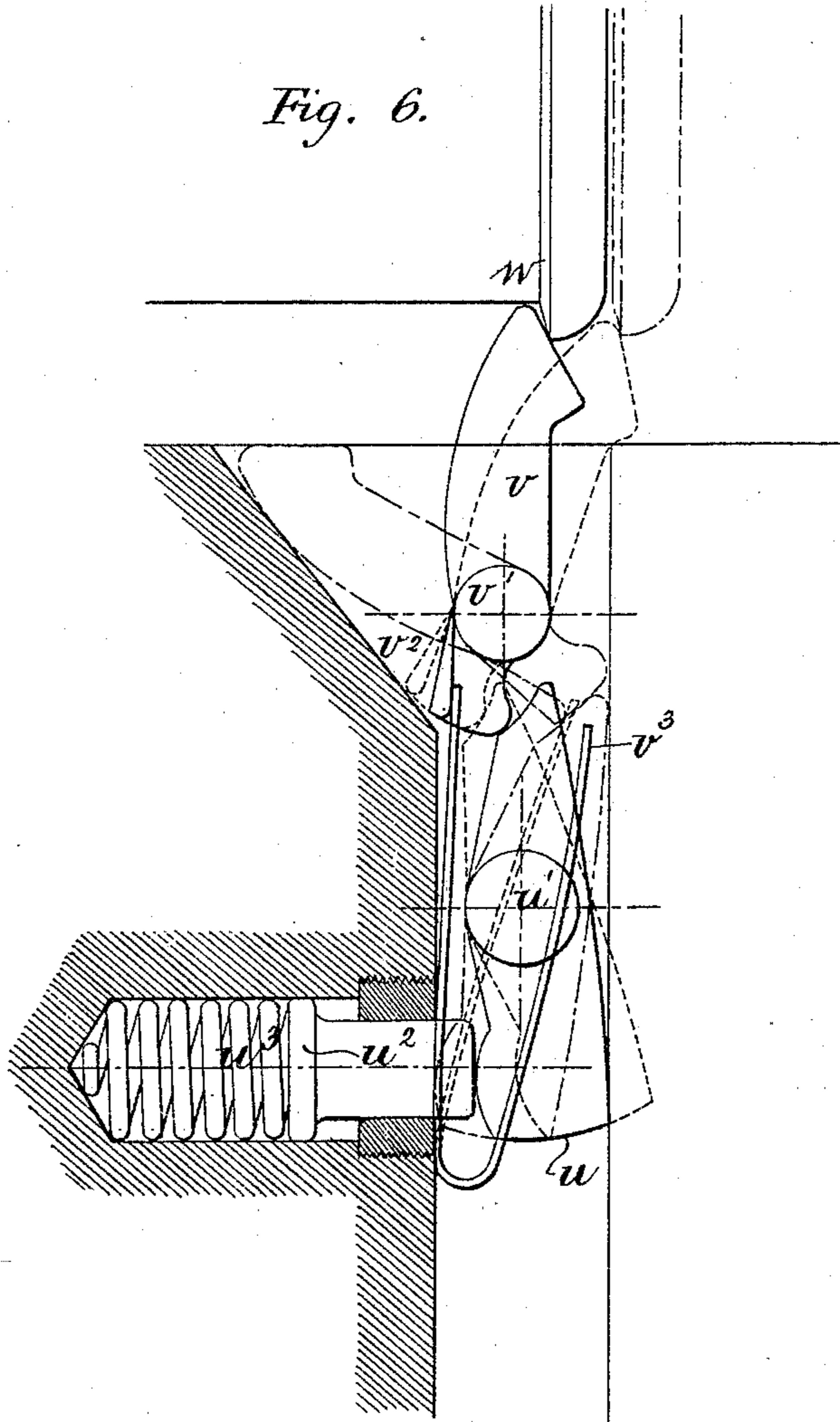

Fig. 7.

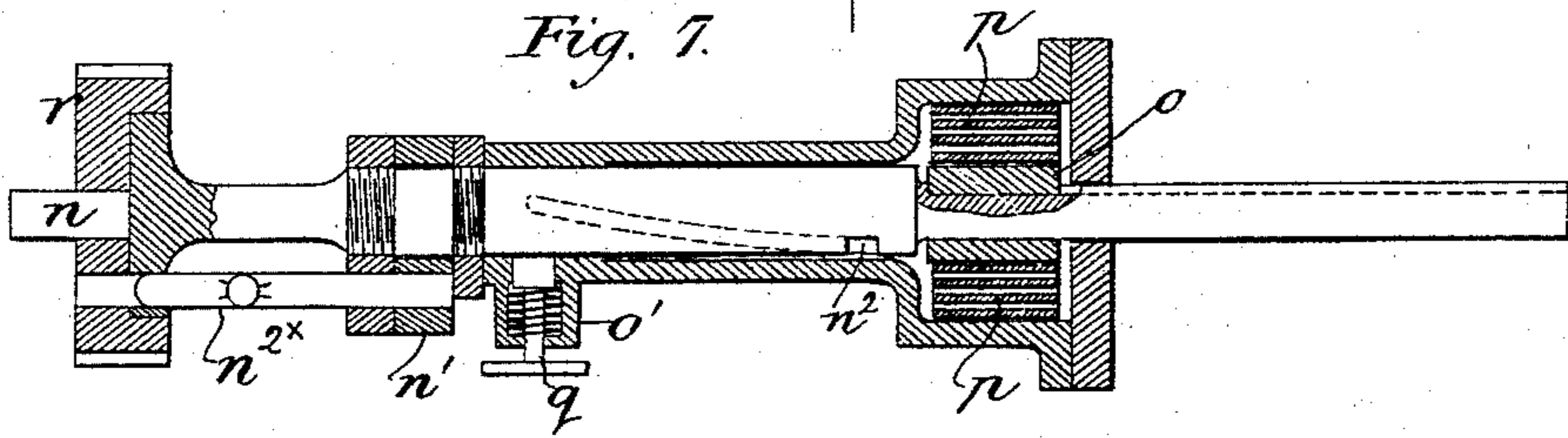

Fig. 8.

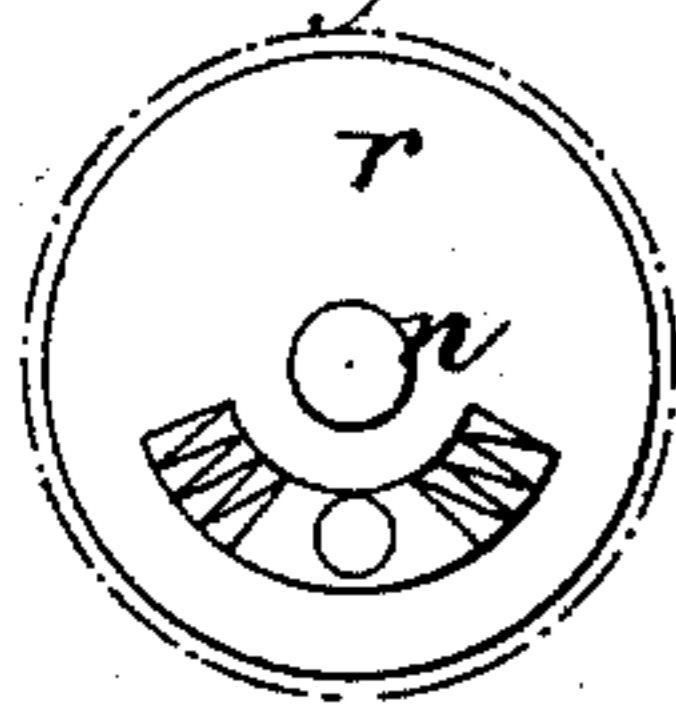
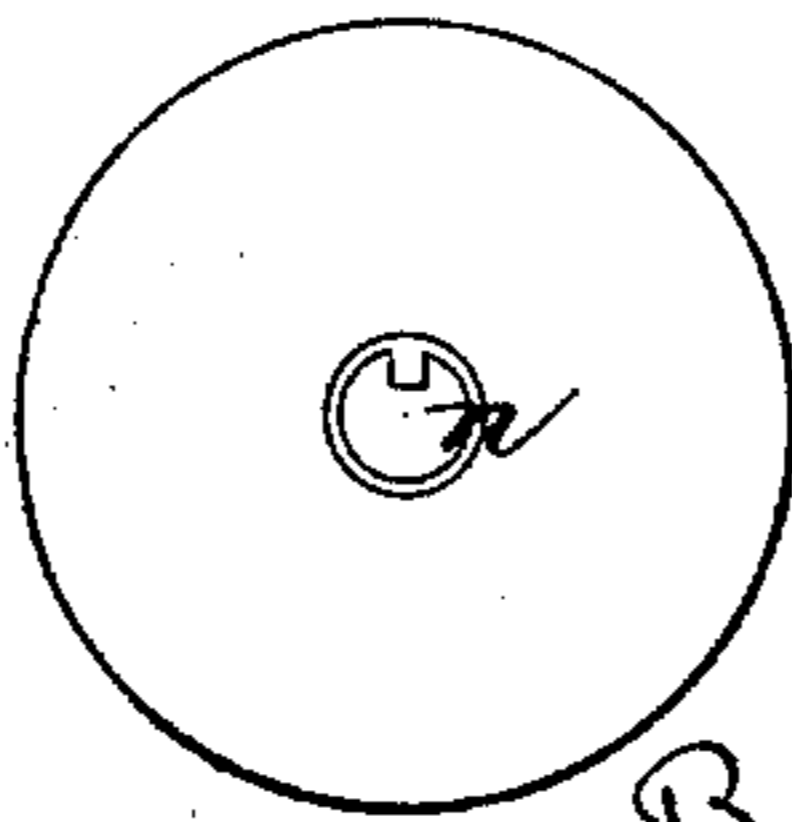

Fig. 9.



Witnesses.
 Baltus D. Long.
 A. H. Smith

Inventor
 Thorsten Nordenfelt.
 By his Atty's.

Baldwin Vanidsen & Wright

UNITED STATES PATENT OFFICE.

THORSTEN NORDENFELT, OF WESTMINSTER, ENGLAND, ASSIGNOR TO THE
MAXIM-NORDENFELT GUNS AND AMMUNITION COMPANY, LIMITED, OF
SAME PLACE.

GUN.

SPECIFICATION forming part of Letters Patent No. 454,374, dated June 16, 1891.

Application filed July 31, 1889. Serial No. 319,307. (No model.) Patented in France February 27, 1889, No. 196,343; in Belgium February 28, 1889, No. 85,196, and in Italy March 31, 1889, No. 25,038.

To all whom it may concern:

Be it known that I, THORSTEN NORDENFELT, civil engineer, a subject of the King of Sweden, residing at 53 Parliament Street, in the city of Westminster, England, have invented certain new and useful Improvements in Automatic or Quick-Firing Guns, (for which I have received Letters Patent in France, No. 196,343, dated February 27, 1889; in Belgium, No. 85,196, dated February 28, 1889, and in Italy, No. 25,038, dated March 31, 1889,) of which the following is a specification.

This invention has for its object apparatus applicable to guns of considerable caliber and which automatically opens and closes the breech and extracts the cartridge-case.

The breech of the gun is closed by a breech-block which enters into it and is secured by a divided screw-thread, so that by a partial turn it can be locked or unlocked. The breech-block is embraced by a ring or holder in which it is able to turn, and the ring or holder can turn about a stud or axis fixed to the breech of the gun and parallel to the bore. There is a pin in the ring or holder which enters a helicoidal groove in the breech-block. This groove is so formed that in opening the breech it first allows the breech-block to be freely turned sufficiently far to disengage the screw-threads, and then it still allows the block to be turned, but only in conjunction with a rearward movement, which takes the breech-block out of the gun. Afterward by the movement of the ring or holder about the stud or axis on which it is mounted the breech-block is carried to one side to leave the bore clear to receive the cartridge. The opening and closing of the breech are performed automatically, and for this purpose a pinion is provided upon the stud. The pinion is in gear with an arc of teeth upon the breech-block.

In opening the breech the pinion in revolving turns the breech-block in the ring or holder as far as the groove and pin admit—that is to say, until the block is unlocked and withdrawn. Then the pinion, still rotating, carries the breech-block and also the ring or holder with it in a circuit around the stud, and so the breech of the gun is left free for

the insertion of a cartridge. The pinion is driven by a wheel mounted on the gun and connected by its axis with the cradle, so that during recoil the axis does not rotate; but when the gun moves forward again the axis turns and operates the breech mechanism to open the breech. The same rotation of the axis winds up a spring which when the gun is loaded is allowed to react, and the mechanism then operates to close the breech. The arrangement which I prefer for imparting movement to this driving-axis is as follows: The axis, which is parallel to the bore of the gun, is carried by the gun in a bearing near its breech end, and it passes with groove and feather through a sleeve which is held in a box upon the cradle. A coiled spring surrounding the sleeve is attached to it by one end, and the other end is fast to the cradle. In the axis a spiral groove is formed, and there is a spring-pin upon the cradle to enter the groove. When the gun is in the firing position, the pin is not in the groove, and during the recoil the pin has no influence and the axis does not revolve; but when the gun has recoiled to its full extent, or nearly so, the pin drops into the groove, and hence when the gun comes forward again (which it immediately does in consequence of the reaction of the springs in the hydraulic control-cylinder) the axis is caused to rotate by the pin following along the spiral groove. Thus the spring coiled around the sleeve on the axis is wound up. The same rotation of the axis causes the withdrawal of the breech-block and opens the breech, as already stated. At the end of the forward movement of the gun the spring-pin upon the cradle runs out of the spiral groove in the axis, and the coiled spring tends to turn the axis back again; but it cannot do so, because a spring-stop in the breech of the gun prevents the return of the ring or holder to replace the breech-block in rear of the open breech of the gun. This spring-stop, however, is arranged to be acted upon by a cartridge-ejector or similar instrument. When the cartridge is inserted into the gun, its base-flange moves this instrument, and thereby withdraws the spring-stop, and the axis is turned

by the spring. This results in the breech of the gun being closed by movements the reverse of those which occasioned the opening. The mechanism is also capable of being operated by hand. For this purpose the wheel upon the axis carried by the gun is not fast upon the axis, but is connected by means of a sliding bolt which is so arranged that the axis is bolted to the gun before it is released from the wheel, so that the initial tension of the spring may not be lost. The bolt does not lock the wheel to the axis with absolute rigidity, for it shoots into a hole in a die which is held central in a curved slot in the wheel between two springs.

In opening the breech by hand the breech-block is turned by means of a hand-lever jointed to it. Thus the block is unlocked and withdrawn, and then the lever is turned over to the other side of the block and used to lift the breech-block and its ring or holder and throw them over to open the breech, as takes place in the course of the automatic working; or for this purpose another handle may be provided on the ring.

Suitable firing mechanism is provided within the breech-block.

Figure 1 is a side elevation of the gun and automatic loading mechanism. It is shown upon a mounting which forms the subject of another application filed March 12, 1889, Serial No. 302,754. Fig. 2 is a plan. Fig. 3 is a longitudinal section, and Fig. 4 is a rear elevation. Fig. 5 is another side elevation. In this figure the shield is partly in section, and many parts not shown in Fig. 1 are here indicated by dotted lines. Fig. 6 shows full size the spring-stop by which the breech is held open until released by the insertion of a cartridge. Fig. 7 shows a longitudinal section of a separated portion of the mechanism. Figs. 8 and 9 are end elevations of these parts.

a is the base of the mounting; b , the upper frame, which can rotate thereon.

c is the cradle carried by its trunnions in bearings on the upper frame.

e is the gun held in the cradle and movable longitudinally in it.

The elevating and training mechanism forms part of the subject-matter of another application filed March 12, 1889, Serial No. 302,754.

$h h$ are hydraulic recoil-cylinders. There are coiled springs (not shown) confined within them, which return the gun after recoil to the firing position.

l is the breech-block. It is able to turn in the ring m .

The breech-plug is locked in the gun by a divided screw, and it has a helicoidal groove in it, with which a pin within the ring m engages. These arrangements, being now well known, are not represented in the drawings.

They are fully described in the specification of a patent granted to me dated August 28, 1888, No. 388,576, and are such that the breech-block being in its place in the gun its rota-

tion causes first the unlocking of the screw and then its rearward movement out of the gun. The breech-block has upon it a ring of teeth l' , and it is provided with a telescopic handle l^2 . The handle is jointed to the block at l^3 , so that the handle may be made to project from the block on either side. In automatic firing no use is made of this handle. n is an axis carried in the bearing n' , fixed to the gun. This axis slides through a bearing upon the cradle and through a sleeve o , contained in a spring-box attached to the cradle.

p is a coiled spring attached by one end to the spring-box and by the other to the sleeve. The sleeve turns with the axis.

n^2 is a spiral groove in the axis n .

q is a spring-pin carried by an arm o' , projecting rearward from the spring-box. The pin q tends inward and drops into the groove n^2 when this groove passes beneath it. This takes place toward the end of the recoil. The pin passes out at the rear end of the groove as the gun reaches its forward position. The axis consequently is turned as the gun runs forward, but not during the recoil. This rotation winds up the spring p .

r is a toothed wheel on axis n .

n^{2x} is a bolt carried by the axis. It shoots into a hole in the wheel r , or rather in a die capable of moving along a curved concentric slot in the wheel, but held central therein between two stiff coiled springs. This bolt is withdrawn when the gun is to be worked by hand, and it then shoots into a hole formed to receive it on the outside of the bearing n' .

s' is a long pinion mounted on a stud s , fixed into the gun parallel to the axis. The pinion s' gears with the wheel r , and also with the teeth l' upon the breech-block. Inclined teeth are employed, as the drawings indicate. The ring m is mounted on the stud s and can turn about it. As the gun runs forward the breech-block turns in the direction indicated by the arrow in Fig. 4. It turns in this direction as far as the stop in the ring allows it to and until it is out of the gun. The ring m , carrying the breech-block in it, then moves around the stud s until it comes to rest against the abutment t . The ring m is provided with a handle m' , which may be used for moving it when working by hand.

u in Fig. 6 is a stop having its fulcrum at u' . It is mounted upon the breech of the gun, being recessed into the face against which the ring m works.

u^2 is a piston, and u^3 a spring which presses the stop outward. When the ring m comes against the abutment t , the stop u starts out in front of the ring and prevents its return.

v is another lever movable about a fulcrum at v' .

w is the cartridge in its place in the gun. On the insertion of the cartridge the base-flange comes against the end of the lever v and moves it to the position in which it is shown by full lines in the figure. The other

end of the lever *v* bears against the adjacent end of the lever *u*, and so this lever also is by the insertion of the cartridge forced against the resistance of the spring u^3 into the position indicated by full lines. In this position it no longer retains the ring *m*, and so the breech closes by the reaction of the spring *p*. When the breech opens, the levers *u* and *v* assume the positions indicated by dotted lines, and the lever *v* aids in ejecting the cartridge-case from the gun. When working the gun by hand, the levers *u* and *v* are put out of use by pressing the lever *v* forward into the recess v^2 , in which it is then retained by the light spring v^3 .

What I claim is—

1. The combination, substantially as herebefore set forth, of the gun, the breech-block locked in the breech of the gun during recoil, and means for automatically rotating the breech-block to unlock and withdraw it from the breech-opening by the forward motion of the gun and for moving the breech-block laterally away from the breech-opening.

2. The combination, substantially as herebefore set forth, of the gun, devices for preventing the withdrawal of the breech-block from the breech-opening during recoil, means for automatically rotating the breech-block to unlock and withdraw it from the breech-opening by the forward motion of the gun, means for moving the breech-block laterally away from the breech-opening, and devices for then holding the breech-block in its withdrawn position.

3. The combination, substantially as herebefore set forth, of the gun, the breech-block locked in the breech of the gun during recoil, means for automatically rotating the breech-block to unlock and withdraw it from the breech-opening by the forward motion of the gun and for moving the breech-block laterally away from the breech-opening, a stop for then holding the breech-block in its withdrawn position, and mechanism for automatically returning the breech-block to the breech-opening while the gun is at rest in the forward or firing position, inserting it therein, and locking it in position when the stop is released.

4. The combination, substantially as herebefore set forth, of the gun, its cradle, the breech-block locked in the gun by a divided screw-thread, springs for moving the gun forward after recoil, mechanism carried by the gun and its cradle for automatically rotating the breech-block to unlock and withdraw it from the breech of the gun and to move it laterally away from the breech-opening by the forward motion of the gun, and devices for then holding the breech-block in its withdrawn position.

5. The combination, substantially as herebefore set forth, of the gun, its cradle, the breech-block, springs for moving the gun forward after recoil, mechanism for automatically rotating the breech-block to unlock and

withdraw it from the breech-opening, means for moving the breech-block away from the breech-opening, a spring automatically placed under tension during the forward movement of the gun and connected with the breech-block-operating mechanism to return the breech-block to the breech-opening in the gun and lock it therein, and a stop to hold the spring under tension and prevent the closing of the breech until the insertion of a cartridge.

6. The combination, substantially as herebefore set forth, of the gun, the breech-block locked in the breech-opening of the gun, a series of teeth formed on the breech-block, the breech-block holder pivoted eccentrically on the breech, a pinion engaging with the teeth on the breech-block, a spring-actuated shaft, a toothed wheel thereon engaging with the pinion which engages with the teeth on the breech-block, and devices connected with the spring-actuated shaft to rotate it and place the spring under tension during the forward movement of the gun after recoil.

7. The combination, substantially as herebefore set forth, of the gun, its cradle, the breech-block, means for locking it in the breech of the gun, a series of teeth on the breech-block, the eccentrically-pivoted breech-block carrier, a pinion engaging with the teeth on the breech-block, a spring-actuated shaft, a wheel thereon engaging with the pinion which engages with the teeth on the breech-block, devices for rotating the shaft when the gun moves forward, and a stop for holding the spring-controlled shaft under tension until the insertion of a cartridge.

8. The combination, substantially as herebefore set forth, of the gun, the breech-block, means for locking the breech-block in position, means for automatically unlocking the breech-block, withdrawing it from the breech-opening, and moving it laterally, a spring, means for automatically placing the spring under tension during the withdrawal of the breech-block, a stop for holding the spring under tension, and devices for withdrawing the stop, releasing the spring, and permitting it to return the breech-block to the breech-opening and lock it therein.

9. The combination, substantially as herebefore set forth, of the gun, the rotatable breech-block, means for locking it in the breech of the gun, a pinion, a series of teeth on the breech-block gearing with the pinion, a spring-actuated shaft having a toothed outer end gearing with the pinion which gears with the breech-block, means for running the gun forward after recoil and automatically rotating the pinion, the breech-block, and the spring-actuated shaft to withdraw the breech-block out of and away from the breech-opening and place the spring-actuated shaft under tension, a stop for holding the spring-actuated shaft under tension and holding the breech-block withdrawn from the breech-opening, and devices for withdrawing the

stop to allow the spring-actuated shaft to revolve, and thereby actuate the pinion to return the breech-block to the breech-opening and lock it therein.

5 10. The combination, substantially as here-
inbefore set forth, of the gun, the rotatable
breech-block locked in the breech of the gun,
a shaft mounted in bearings on the gun, a
spring connected therewith, a spring-pin
10 which engages with a groove in the shaft,
gearing between the shaft and the breech-
block, means for moving the gun forward
after recoil to unlock and withdraw the breech-
block from the breech-opening and place the
15 spring-shaft under tension, and a stop for
then holding the breech-block away from the

breech-opening and holding the spring-shaft
under tension.

11. The combination, substantially as here-
inbefore set forth, of the gun, the breech- 20
block, the spring, the parts connecting the
gun with the spring, the parts connecting the
spring with the breech-block, and the bolt re-
taining the breech-block, the whole so ar-
ranged that as the gun runs forward the 25
spring is constrained and operates to close
the breech when on the insertion of a car-
tridge the bolt is withdrawn.

THORSTEN NORDENFELT.

Witnesses:

W. R. LUNN,
F. A. NOEL.